

10A Avg.

600 Volts

FRED

TSU10B60

■最大定格 Maximum Ratings

Item	Symbol	Conditions	Unit
くり返しピーク逆電圧 Repetitive Peak Reverse Voltage	$V_{RRM}$	600	V
平均整流電流 Average Rectified Forward Current	$I_O$	50Hz, 正弦半波通電抵抗負荷 50Hz Half Sine Wave Resistive Load	$T_c=60^\circ\text{C}$ 10
実効順電流 R.M.S. Forward Current	$I_{F(RMS)}$	15.7	A
サージ順電流 Surge Forward Current	$I_{FSM}$	100 50Hz正弦全波, 1サイクル, 非くり返し 50Hz Full Sine Wave, 1cycle, Non-repetitive	A
動作接合温度範囲 Operating Junction Temperature Range	$T_{jw}$	-40~+150	$^\circ\text{C}$
保存温度範囲 Storage Temperature Range	$T_{stg}$	-40~+150	$^\circ\text{C}$

■OUTLINE DRAWING(mm)

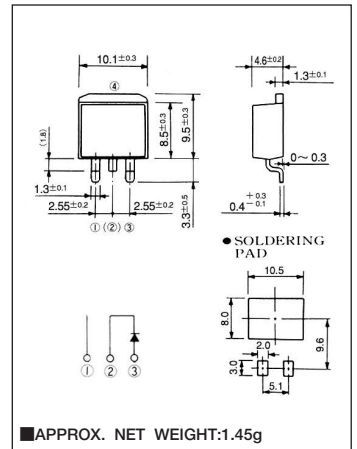

■電氣的・熱的特性 Electrical/Thermal Characteristics

Item	Symbol	Conditions	Min.	Typ.	Max.	Unit
ピーク逆電流 Peak Reverse Current	$I_{RM}$	$T_j=25^\circ\text{C}, V_{RM}=V_{RRM}$	—	—	30	$\mu\text{A}$
ピーク順電圧 Peak Forward Voltage	$V_{FM}$	$T_j=25^\circ\text{C}, I_{FM}=10\text{A}$	—	2.3	2.7	V
逆回復時間 Reverse Recovery Time	$t_{rr}$	$I_{FM}=10\text{A}, -di/dt=50\text{A}/\mu\text{s}, T_j=25^\circ\text{C}$	—	25	40	ns
熱抵抗 Thermal Resistance	$R_{th(j-c)}$	接合部・ケース間 Junction to Case	—	—	4	$^\circ\text{C}/\text{W}$

■定格・特性曲線

