

6A Avg.

30 Volts

SBD

EA60QC03L

最大定格 Maximum Ratings

Item	Symbol	Conditions	Unit
くり返しピーク逆電圧 Repetitive Peak Reverse Voltage	V_{RRM}	30	V
平均整流電流 Average Rectified Forward Current	I_O	50Hz、正弦全波通電抵抗負荷 50Hz Full Sine Wave Resistive Load	$T_a=20^{\circ}C$ 2.0 A
			$T_c=111^{\circ}C$ 6.0 A
実効順電流 R.M.S. Forward Current	$I_F(RMS)$	6.66	A
サージ順電流 Surge Forward Current	I_{FSM}	45 50Hz正弦全波, 1サイクル, 非くり返し 50Hz Full Sine Wave, 1cycle, Non-repetitive	A
動作接合温度範囲 Operating Junction Temperature Range	T_{jw}	-40~+150	$^{\circ}C$
保存温度範囲 Storage Temperature Range	T_{stg}	-40~+150	$^{\circ}C$

OUTLINE DRAWING(mm)

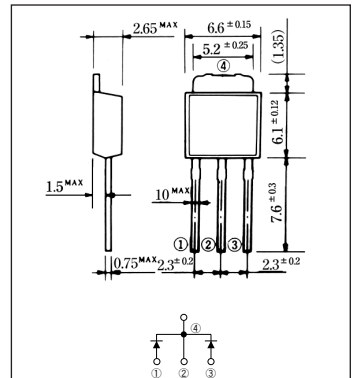

APPROX. NET WEIGHT:0.35g

電氣的・熱的特性 Electrical/Thermal Characteristics

Item	Symbol	Conditions	Min.	Typ.	Max.	Unit
ピーク逆電流 Peak Reverse Current	I_{RM}	$T_j=25^{\circ}C, V_{RM}=V_{RRM}$, 一素子あたり Per Diode	—	—	3	mA
ピーク順電圧 Peak Forward Voltage	V_{FM}	$T_j=25^{\circ}C, I_{FM}=3A$, 一素子あたり Per Diode	—	—	0.45	V
熱抵抗 Thermal Resistance	$R_{th(j-a)}$	接合部・周囲間 Junction to Ambient	—	—	80	$^{\circ}C/W$
	$R_{th(j-c)}$	接合部・ケース間 Junction to Case	—	—	5	$^{\circ}C/W$

* Print Land=20×20mm

定格・特性曲線

