

4A Avg.

60 Volts

SBD

EA40QC06

■最大定格 Maximum Ratings

Item	Symbol	Conditions	Unit
くり返しピーク逆電圧 Repetitive Peak Reverse Voltage	$V_{RRM}$	60	V
非くり返しピーク逆電圧 Non-repetitive Peak Reverse Voltage	$V_{RSM}$	65	V
平均整流電流 Average Rectified Forward Current	$I_O$	50Hz、正弦全波通電抵抗負荷 50Hz Full Sine Wave Resistive Load	$T_a=38^\circ\text{C}$ 1.3 A
			$T_c=122^\circ\text{C}$ 4.0 A
実効順電流 R.M.S. Forward Current	$I_{F(RMS)}$	4.44	A
サージ順電流 Surge Forward Current	$I_{FSM}$	40 50Hz正弦全波、1サイクル、非くり返し 50Hz Full Sine Wave, 1cycle, Non-repetitive	A
動作接合温度範囲 Operating Junction Temperature Range	$T_{jw}$	-40~+150	$^\circ\text{C}$
保存温度範囲 Storage Temperature Range	$T_{stg}$	-40~+150	$^\circ\text{C}$

■OUTLINE DRAWING(mm)

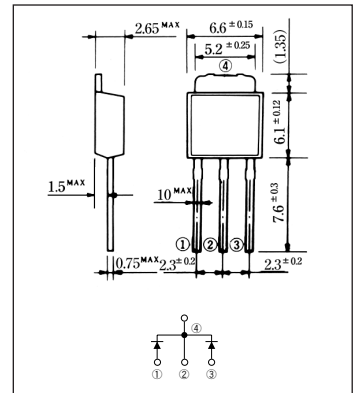

■APPROX. NET WEIGHT:0.35g

■電氣的・熱的特性 Electrical/Thermal Characteristics

Item	Symbol	Conditions	Min.	Typ.	Max.	Unit
ピーク逆電流 Peak Reverse Current	$I_{RM}$	$T_j=25^\circ\text{C}$ , $V_{RM}=V_{RRM}$ , 一素子あたり Per Diode	—	—	2	mA
ピーク順電圧 Peak Forward Voltage	$V_{FM}$	$T_j=25^\circ\text{C}$ , $I_{FM}=2\text{A}$ , 一素子あたり Per Diode	—	—	0.60	V
熱抵抗 Thermal Resistance	$R_{th(j-a)}$	接合部・周囲間 Junction to Ambient	—	—	80	$^\circ\text{C/W}$
	$R_{th(j-c)}$	接合部・ケース間 Junction to Case	—	—	5.5	$^\circ\text{C/W}$

\* Print Land=20×20mm

■定格・特性曲線

