

2A Avg.

100 Volts

SBD

EA20QC10

■最大定格 Maximum Ratings

Item	Symbol	Conditions	Unit
くり返しピーク逆電圧 Repetitive Peak Reverse Voltage	V_{RRM}	100	V
平均整流電流 Average Rectified Forward Current	I_O	50Hz、正弦全波抵抗負荷 50Hz Full Sine Wave Resistive Load	$T_a=32^{\circ}C$ 1.6 A
			$T_c=138^{\circ}C$ 2.0 A
実効順電流 R.M.S. Forward Current	$I_F(RMS)$	2.22	A
サージ順電流 Surge Forward Current	I_{FSM}	20 50Hz正弦全波, 1サイクル, 非くり返し 50Hz Full Sine Wave, 1cycle, Non-repetitive	A
動作接合温度範囲 Operating Junction Temperature Range	T_{jw}	-40~+150	$^{\circ}C$
保存温度範囲 Storage Temperature Range	T_{stg}	-40~+150	$^{\circ}C$

■OUTLINE DRAWING(mm)

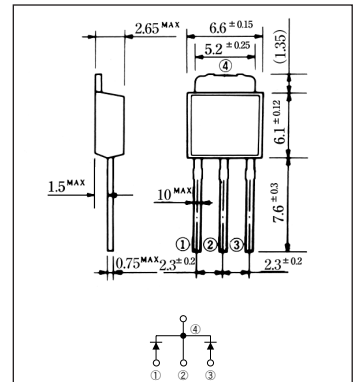

■APPROX. NET WEIGHT:0.35g

■電氣的・熱的特性 Electrical/Thermal Characteristics

Item	Symbol	Conditions	Min.	Typ.	Max.	Unit
ピーク逆電流 Peak Reverse Current	I_{RM}	$T_j=25^{\circ}C, V_{RM}=V_{RRM}$, 一素子あたり Per Diode	—	—	0.5	mA
ピーク順電圧 Peak Forward Voltage	V_{FM}	$T_j=25^{\circ}C, I_{FM}=1A$, 一素子あたり Per Diode	—	—	0.85	V
熱抵抗 Thermal Resistance	$R_{th(j-a)}$	接合部・周囲間 Junction to Ambient	—	—	80	$^{\circ}C/W$
	$R_{th(j-c)}$	接合部・ケース間 Junction to Case	—	—	6	$^{\circ}C/W$

* Print Land=20×20mm

■定格・特性曲線

