

3A Avg.

30 Volts

SBD

EA30QS03L

最大定格 Maximum Ratings

Item	Symbol	Conditions	Unit
くり返しピーク逆電圧 Repetitive Peak Reverse Voltage	V_{RRM}	30	V
平均整流電流 Average Rectified Forward Current	I_O	50Hz、正弦半波通電抵抗負荷 50Hz Half Sine Wave Resistive Load	1.7 A 3.0 A
実効順電流 R.M.S. Forward Current	$I_F(RMS)$	4.71	A
サージ順電流 Surge Forward Current	I_{FSM}	45 50Hz正弦半波、1サイクル、非くり返し 50Hz Half Sine Wave, 1cycle, Non-repetitive	A
動作接合温度範囲 Operating Junction Temperature Range	T_{jw}	-40~+150	°C
保存温度範囲 Storage Temperature Range	T_{stg}	-40~+150	°C

OUTLINE DRAWING(mm)

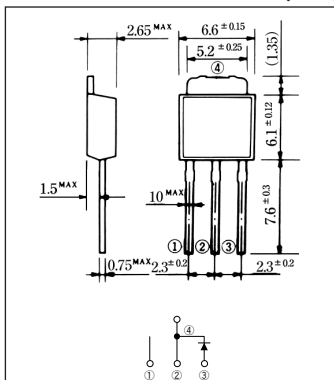

APPROX. NET WEIGHT:0.35g

電氣的・熱的特性 Electrical/Thermal Characteristics

Item	Symbol	Conditions	Min.	Typ.	Max.	Unit
ピーク逆電流 Peak Reverse Current	I_{RM}	$T_j = 25^\circ\text{C}, V_{RM} = V_{RRM}$	—	—	3	mA
ピーク順電圧 Peak Forward Voltage	V_{FM}	$T_j = 25^\circ\text{C}, I_{FM} = 3\text{A}$	—	—	0.45	V
熱抵抗 Thermal Resistance	$R_{th(j-a)}$	接合部・周囲間 Junction to Ambient	—	—	80	°C/W
	$R_{th(j-c)}$	接合部・ケース間 Junction to Case	—	—	6	°C/W

* P.C.Board mounted Print Land=20×20mm

定格・特性曲線

