

1A Avg. 200 Volts Standard Recovery Diode 10EDA20

最大定格 Maximum Ratings

Item	Symbol	Conditions	Unit
くり返しピーク逆電圧 Repetitive Peak Reverse Voltage	V_{RRM}	200	V
平均整流電流 Average Rectified Output Current	I_O	50Hz 正弦半波抵抗負荷 50Hz half sine wave Resistance load	$T_a=39^\circ\text{C}^{*1}$ 1.0 $T_a=26^\circ\text{C}^{*2}$ 0.9
実効順電流 R.M.S. Forward Current	$I_F(\text{RMS})$	1.57	A
サージ順電流 Surge Forward Current	I_{FSM}	45 50Hz正弦半波, 1サイクル, 非くり返し 50Hz Half Sine Wave, 1cycle, Non-repetitive	A
動作接合温度範囲 Operating Junction Temperature Range	T_{jw}	-40~+150	$^\circ\text{C}$
保存温度範囲 Storage Temperature Range	T_{stg}	-40~+150	$^\circ\text{C}$

OUTLINE DRAWING(mm)

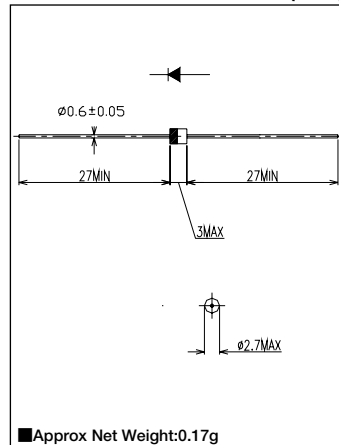

電氣的・熱的特性 Electrical/Thermal Characteristics

Item	Symbol	Conditions	Min.	Typ.	Max.	Unit
ピーク逆電流 Peak Reverse Current	I_{RM}	$T_j=25^\circ\text{C}, V_{RM}=V_{RRM}$	—	—	10	μA
ピーク順電圧 Peak Forward Voltage	V_{FM}	$T_j=25^\circ\text{C}, I_{FM}=1\text{A}$	—	—	1.0	V
熱抵抗 Thermal Resistance	$R_{th(j-a)}$	接合部・周囲間 Junction to Ambient	—	—	110	$^\circ\text{C}/\text{W}$
		プリント基板実装*1 単体フィン無し*2	—	—	140	$^\circ\text{C}/\text{W}$

*1: プリント基板実装 / P.C. Board mounted (L=3mm, Print Lands=5×5 mm, Both Sides)
*2: 単体フィン無し / Without Fin or P.C. Board mounted

定格・特性曲線

