

## Thyristor – Thyristor Module, 25A

### Features

- Improved glass passivation for high reliability
- Exceptional stability at high temperatures
- High di/dt and dv/dt capabilities
- Low thermal resistance

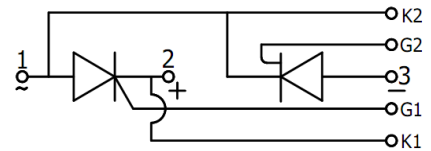

Maximum Ratings ( $T_A = 25^{\circ}\text{C}$ unless otherwise noted)			
Parameter	Symbol	Values	Units
Maximum average forward current @ $T_J = 85^{\circ}\text{C}$	$I_{F(AV)}$	25	A
Maximum average RMS forward current	$I_{F(RMS)}$	50	A
Maximum non-repetitive surge current	$I_{FSM}$	450	A
Maximum $I^2t$ for fusing @ $t = 10\text{ms}$	$I^2t$	1150	$\text{A}^2\text{s}$



Thermal & Mechanical Specifications ( $T_A = 25^{\circ}\text{C}$ unless otherwise noted)			
Parameter	Symbol	Values	Units
Operating junction temperature range	$T_J$	-65 to +125	$^{\circ}\text{C}$
Thermal resistance, junction to case	$R_{th(JC)}$	0.9	$^{\circ}\text{C}/\text{W}$

Electrical Characteristics ( $T_A = 25^{\circ}\text{C}$ unless otherwise noted)			
Parameter	Symbol	Values	Units
Maximum average on-state current	$I_{T(max)}$	25	A
Maximum repetitive peak reverse voltage range	$V_{RRM}$	200 to 1800	V
Forward voltage drop	$V_{FM}$	1.3	V
Gate current required to trigger	$I_{GT}$	100	A
Gate voltage required to trigger	$V_{GT}$	2	V
Holding current range	$I_H$	5 to 100	mA
Maximum latching current	$I_L$	300	mA
Critical rate of rise of off-state voltage	dv/dt	300	$\text{V}/\mu\text{s}$
RMS isolated voltage	$V_{ISO}$	2500	V

## Package Outline

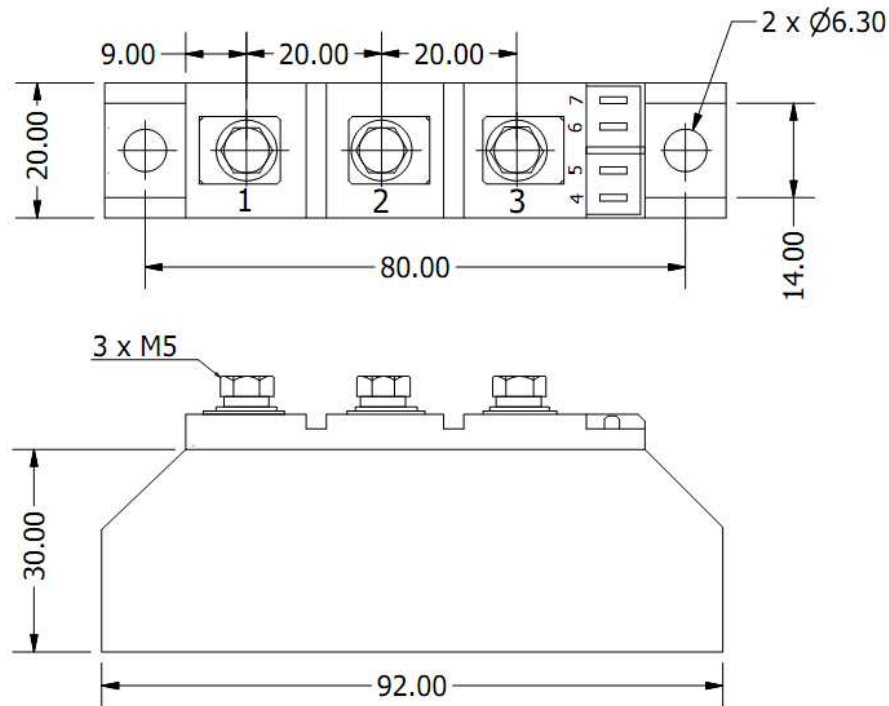

ALL DIMENSIONS ARE IN MM

## Ordering Table

25	NTT	-	120
1	2	3	4

1 – Current Rating =  $I_F (AV)$

2 – Power Module

- > DD = Diode-Diode
- > TD = Thyristor-Diode
- > TT = Thyristor-Thyrisor

3 – Polarity:

- > None = Series Connection
- > A = Common Anode
- > K = Common Cathode

4 – Voltage,  $V_{RRM} \times 10$