

## Three – Phase Bridge Rectifier

### Features

- Easy connections
- Excellent power volume ratio
- Insulated type

Voltage Ratings ( $T_J = 25^{\circ}\text{C}$ unless otherwise noted)				
Type number	Voltage code	VRRM, Max. repetitive peak reverse voltage (V)	VRSM, Max. non-repetitive peak reverse voltage (V)	IRRM max @ $T_J$ max (mA)
90MDS	80	800	900	10
	100	1000	1100	
	120	1200	1300	
	140	1400	1500	
	160	1600	1700	



MDS

Thermal and Mechanical Specifications ( $T_A = 250\text{C}$ unless otherwise noted)			
Parameters	Symbol	Values	Units
Maximum operating junction temperature range	$T_J$	- 40 to + 150	$^{\circ}\text{C}$
Maximum storage temperature range	$T_{\text{Stg}}$	- 40 to + 150	$^{\circ}\text{C}$
Maximum thermal resistance, junction to case	$R_{\text{th}(JC)}$	DC operation per module	0.21
		DC operation per junction	1.26
		120 Rect conduction angle per module	0.25
		120 Rect conduction angle per junction	1.47
Maximum thermal resistance, case to heatsink	$R_{\text{th}(CS)}$	0.03	$^{\circ}\text{C}/\text{W}$
Mounting torque $\pm 10\%$	T	to heatsink	4 to 6
		to terminal	3 to 4
Approximate weight		176	g

Electrical Specifications ( $T_J = 25^{\circ}\text{C}$ unless otherwise noted)						
Parameters	Conditions		Symbol	Values	Units	
Maximum DC output current	120° Rect conduction angle, $T_C = 85^{\circ}\text{C}$		$I_0$	90	A	
Maximum peak one-cycle forward, non-repetitive surge current	$t = 10\text{ms}$	No voltage reappplied	$T_J = T_J \text{ max.}$	$I_{FSM}$	770	A
	$t = 8.3\text{ms}$					
	$t = 8.3\text{ms}$	100% $V_{RRM}$ reappplied			650	
	$t = 10\text{ms}$				680	
Maximum $I^2t$ for fusing	$T = 8.3\text{ms}$	No voltage reappplied	$T_J = T_J \text{ max.}$	$I^2t$	3000	$\text{A}^2\text{s}$
	$T = 10\text{ms}$					
	$T = 8.3\text{ms}$	100% $V_{RRM}$ reappplied			2100	
	$T = 10\text{ms}$				1900	
Maximum $J^2vt$ for fusing	$T = 0.1$ to $10\text{ms}$ , no voltage reappplied		$J^2vt$	30000	$\text{A}^2\text{Vs}$	
Low level value of threshold voltage	$[16.7\% * \pi * I_{F(AV)} < I < \pi * I_{F(AV)}]$ , @ $T_J \text{ max}$		$V_{F(TO)1}$	0.89	V	
High level value of threshold voltage	$[I > \pi * I_{F(AV)}]$ , @ $T_J \text{ max}$		$V_{F(TO)2}$	1.05	V	
Low level value of forward slope resistance	$[16.7\% * \pi * I_{F(AV)} < I < \pi * I_{F(AV)}]$ , @ $T_J \text{ max}$		$r_1$	5.11	$\text{m}\Omega$	
High level value of forward slope resistance	$[I > \pi * I_{F(AV)}]$ , @ $T_J \text{ max}$		$r_2$	4.64	$\text{m}\Omega$	
Maximum forward voltage drop	$I_{pk} = 100\text{A}$ , $t_p = 400 \mu\text{s}$ single junction		$V_{FM}$	1.6	V	
RMS isolation voltage	$f = 50\text{Hz}$ , $t = 1\text{ms}$ , all terminals shorted		$V_{ISO}$	4000	V	

## Diode Configuration

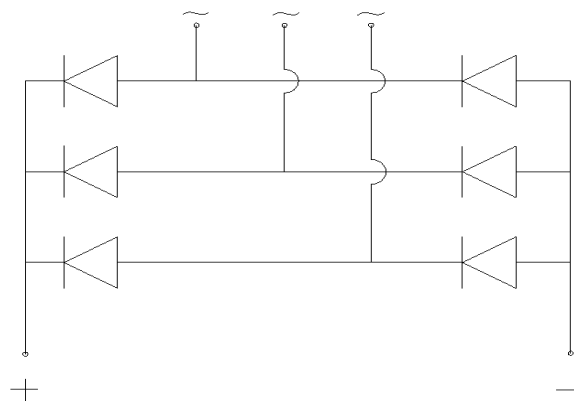

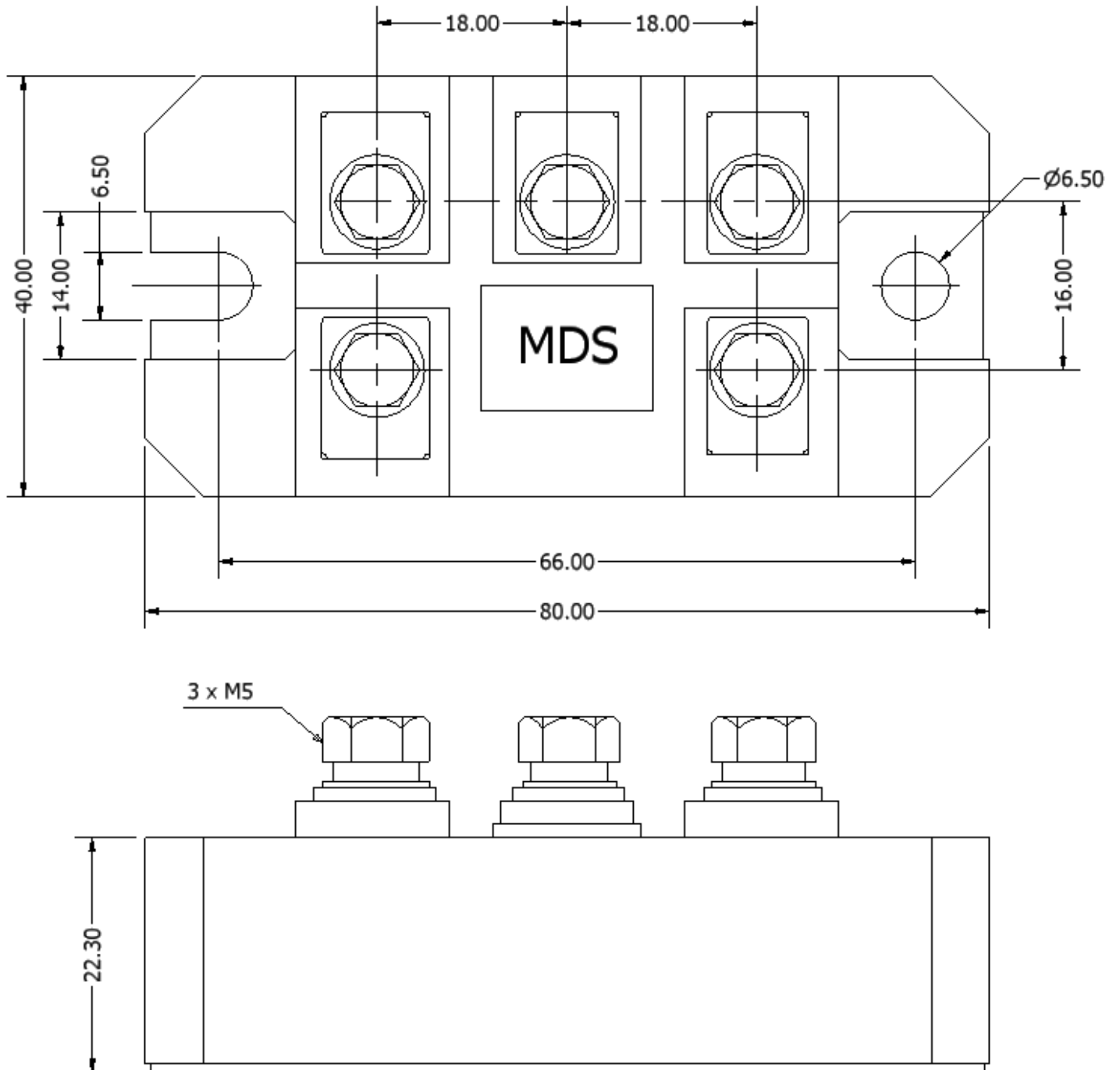

ALL DIMENSIONS IN MM