

# PCAN-PC/104-Plus Quad

Four-Channel CAN Interface for  
PC/104-Plus

User Manual v1.0.1

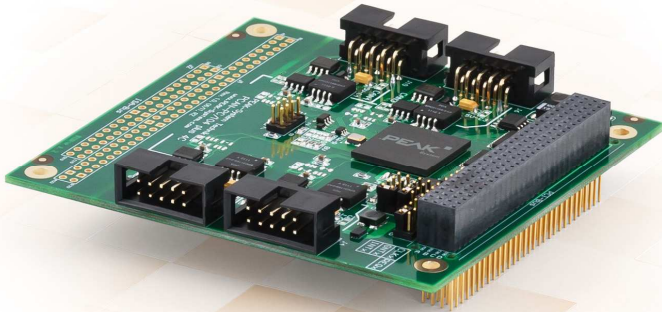

**PEAK**  
System

## Products taken into account

Product Name	Model	Part Number
PCAN-PC/104-Plus Quad	Four CAN channels	IPEH-002099

On request you can get the card with stack-through connectors for the ISA bus.

CANopen® and CiA® are registered community trade marks of CAN in Automation e.v.

All other product names mentioned in this manual may be the trademarks or registered trademarks of their respective companies. They are not explicitly marked by "™" and "®".

© 2012 PEAK-System Technik GmbH

PEAK-System Technik GmbH  
Otto-Roehm-Strasse 69  
64293 Darmstadt  
Germany

Phone: +49 (0)6151 8173-20  
Fax: +49 (0)6151 8173-29

[www.peak-system.com](http://www.peak-system.com)  
[info@peak-system.com](mailto:info@peak-system.com)

Document version 1.0.1 (2012-07-09)

# Contents

<b>1</b>	<b>Introduction</b>	<b>5</b>
1.1	Properties at a Glance	5
1.2	System Requirements	6
1.3	Scope of Supply	7
<b>2</b>	<b>Configuring and Installing the Card and the Software</b>	<b>8</b>
2.1	Configuring the Card	8
2.1.1	Setting the Position in the PC/104 Stack	8
2.2	Installing the Software and the Card	10
2.3	Notes for the ISA Bus Stack-through Connection	12
<b>3</b>	<b>Connecting the CAN Bus</b>	<b>13</b>
3.1	D-Sub Connector	13
3.2	Supplying External Devices via the CAN Connector	15
3.3	Cabling	17
3.3.1	Termination	17
3.3.2	Example of a Connection	17
3.3.3	Maximum Bus Length	18
<b>4</b>	<b>Using the Software</b>	<b>19</b>
4.1	CAN Monitor PCAN-View for Windows	19
4.1.1	Receive/Transmit Tab	21
4.1.2	Trace Tab	23
4.1.3	Status Bar	24
4.2	Linking Own Programs with PCAN-Basic	25
4.2.1	Features of PCAN-Basic	26
4.2.2	Principle Description of the API	27
4.2.3	Notes about the License	28

<b>5 Technical Specifications PCAN-PC/104-Plus Quad</b>	<b>29</b>
<b>Appendix A CE Certificate</b>	<b>31</b>
<b>Appendix B Dimension Drawing</b>	<b>32</b>
<b>Appendix C Quick Reference</b>	<b>33</b>

# 1 Introduction

The PCAN-PC/104-Plus Quad card enables the connection of four CAN networks to a PC/104-Plus system. Up to four cards can be operated, with each piggy-backing on the next. The CAN bus is connected using a 9-pin D-Sub plug on the slot brackets supplied. There is galvanic isolation of up to 500 Volts between the computer and CAN sides. Device drivers and a programming interface exist for different operating systems, so programs can easily access a connected CAN bus.



**Tip:** At the end of this manual (Appendix C) you can find a Quick Reference with brief information about the installation and operation of the PCAN-PC/104-Plus Quad card.

## 1.1 Properties at a Glance

- Form factor PC/104
- Use of the 120-pin connection for the PCI bus
- Up to four cards can be used in one system
- Bit rates up to 1 Mbit/s
- Compliant with CAN specifications 2.0A (11-bit ID) and 2.0B (29-bit ID)
- Connection to CAN bus through D-Sub slot brackets, 9-pin (in accordance with CiA® 102)
- NXP SJA1000-compatible CAN controller (FPGA implementation)
- NXP PCA82C251 CAN transceiver

- └ 5-Volts supply to the CAN connection can be connected through a solder jumper, e.g. for external bus converter
- └ 4 High-speed CAN channels (ISO 11898-2)
- └ Galvanic isolation on the CAN connection up to 500 V, separate for each CAN channel
- └ Extended operating temperature range from -40 to 85 °C (-40 to 185 °F)



**Note:** This manual describes the use of the PCAN-PC/104-Plus Quad card with **Windows**. You can find device drivers for **Linux** and the corresponding application information on the provided DVD in the directory branch `Develop` and on our website under [www.peak-system.com/linux](http://www.peak-system.com/linux).

## 1.2 System Requirements

- └ PC/104 stack with PCI-Bus (according to the specification PC/104-Plus)
- └ Operating system Windows 7/Vista/XP (32/64-bit) or Linux (32/64-bit)

## 1.3 Scope of Supply

- └ PCAN-PC/104-Plus Quad card
- └ Two Slot brackets with D-Sub connectors for the CAN bus
- └ Device drivers for Windows 7/Vista/XP (32/64-bit) and Linux (32/64-bit)
- └ PCAN-View CAN monitor for Windows
- └ PCAN-Basic programming interface consisting of an interface DLL, examples, and header files for all common programming languages
- └ Manual in PDF format

## 2 Configuring and Installing the Card and the Software

This chapter covers the configuration for the PCAN-PC/104-Plus Quad card and the software setup under Windows and the installation of the card in the PC/104 stack.



**Note:** Under Windows the PCAN-PC/104-Plus Quad card is run as a PCAN-PC/104-Plus card.

### 2.1 Configuring the Card

Before installing the PCAN-PC/104-Plus Quad card into a PC/104 stack, you must configure it using jumpers on the PCB.



**Attention!** Electrostatic discharge (ESD) can damage or destroy components on the PCAN-PC/104-Plus Quad card. Take precautions to avoid ESD when handling the card.

#### 2.1.1 Setting the Position in the PC/104 Stack

The PCAN-PC/104-Plus Quad card must be adjusted to a specific position in the stack by setting the appropriate jumpers. The position number results from the distance to the host.

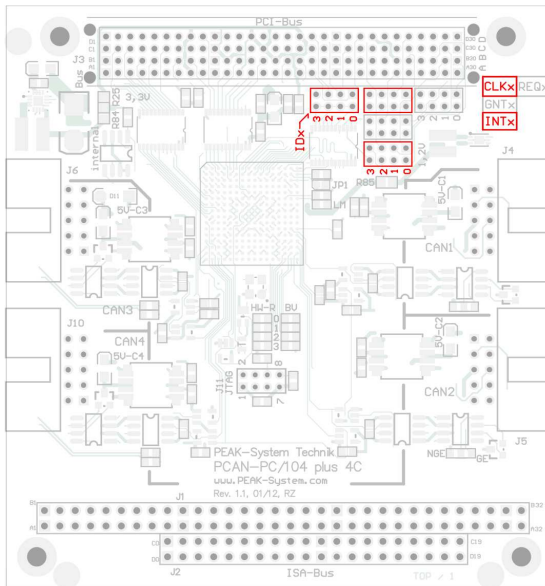

Figure 1: Jumper fields IDx, CLKx, and INTx on the PCAN-PC/104-Plus Quad card

Jumper	Signal	Position in the PC/104 stack in relation to the host			
		1	2	3	4
IDx	ID Select	0	1	2	3
CLKx	Clock Select	0	1	2	3
INTx	Interrupt Select	0	1	2	3

Because the PCI bus master operation is not used by the card, the jumper fields REQx and GNTx remain empty.

## 2.2 Installing the Software and the Card

Setup the driver before installing the PCAN-PC/104-Plus Quad card in the PC/104 stack.

▶ Do the following to setup the driver:

1. Make sure that you are logged in as user with administrator privileges (not needed for normal use of the card later on).
2. Insert the supplied DVD into the appropriate drive of the computer. Usually a navigation program appears a few moments later. If not, start the file `Intro.exe` from the root directory of the DVD.
3. On the page **English > Drivers** activate the entry **PCAN-PCI**.
4. Click on **Install now**. The setup program for the driver is executed.
5. Follow the instructions of the program.



**Tip:** If you don't want to install the CAN monitor PCAN-View for Windows onto the hard disk together with the driver, you have the option to start the program later directly from DVD without prior installation.



▶ Do the following to complete the initialization:

1. Turn on the computer and start Windows. Make sure that you are logged in as user with administrator privileges.

Windows notifies that new hardware has been detected.

2. Windows XP only: A Wizard dialog box appears. Follow its instruction. Deny the search for driver software at Windows Update and select the automatic software installation during the procedure

All Windows operating systems: The drivers are found and installed by Windows.

3. Afterwards you can work as user with restricted rights again.

After the driver has been successfully set up you can find the entry "PCAN-PC/104-Plus" in the branch "CAN-Hardware" of the Windows Device Manager.

## 2.3 Notes for the ISA Bus Stack-through Connection

If you want to use additional modules in the PC/104 stack being connected via the ISA bus, the connections J1 and J2 must be equipped with stack-through connectors. On request you get a respective version of the PCAN-PC/104-Plus Quad card.

Taking the host as point of view, PC/104 modules with ISA bus must be plugged onto the stack behind any module with PCI bus. The signals of the ISA bus are connected through and not used by the PCAN-PC/104-Plus Quad card.

## 3 Connecting the CAN Bus

### 3.1 D-Sub Connector

A High-speed CAN bus (ISO 11898-2) is connected to the 9-pin D-Sub connector. The pin assignment for CAN corresponds to the specification CiA® 102.

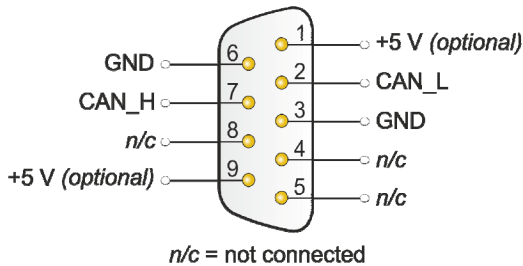

Figure 3: Pin assignment High-speed CAN bus  
(view onto a D-Sub connector of the slot bracket)

With the pins 1 and 9 devices with low power consumption (e.g. external bus converters) can be directly supplied via the CAN connector. At delivery these pins are not activated. You can find a detailed description in section 3.2 on page 15.

The pin assignment between a 10-pin socket on the PCAN-PC/104-Plus Quad card and a D-Sub male connector is as follows:

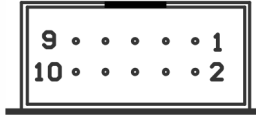

Figure 4: Numbering at the 10-pin socket

Pin	Assignment	Assignment D-Sub
1	+5 V (optional)	1
2	GND	6
3	CAN_L	2
4	CAN_H	7
5	GND	3
6	not connected	8
7	not connected	4
8	+5 V (optional)	9
9	not connected	5
10	not connected	



**Tip:** You can connect a CAN bus with a different transmission standard via a bus converter. PEAK-System offers different bus converter modules (e.g. PCAN-TJA1054 for a Low-speed CAN bus according to ISO 11898-3).

## 3.2 Supplying External Devices via the CAN Connector

A 5-Volt supply can optionally be routed to pin 1 and/or pin 9 of a D-Sub connector by setting solder bridges on the PCAN-PC/104-Plus Quad card (independently for each connector). Thus external devices with low power consumption (e.g. bus converters) can be directly supplied via the CAN connector.

When using this option the 5-Volt supply is connected to the power supply of the PC/104 stack and is not fused separately. By using interconnected DC/DC converter the current output is limited to 100 mA.

➡ Proceed as follows to activate the 5-Volt supply:

Set the solder bridges on the PCAN-PC/104-Plus Quad card according to the desired settings. During this procedure take especially care not to produce unwanted short circuits on the card.

Figure 5 shows the positions of the solder fields on the PCAN-PC/104-Plus Quad card. If a solder bridge is set, the 5-volt supply is forwarded to the corresponding pin.

 **Note:** The pin labels for the CAN connector are related to the 9-pin D-Sub connector being connected via a cable to a socket on the card.

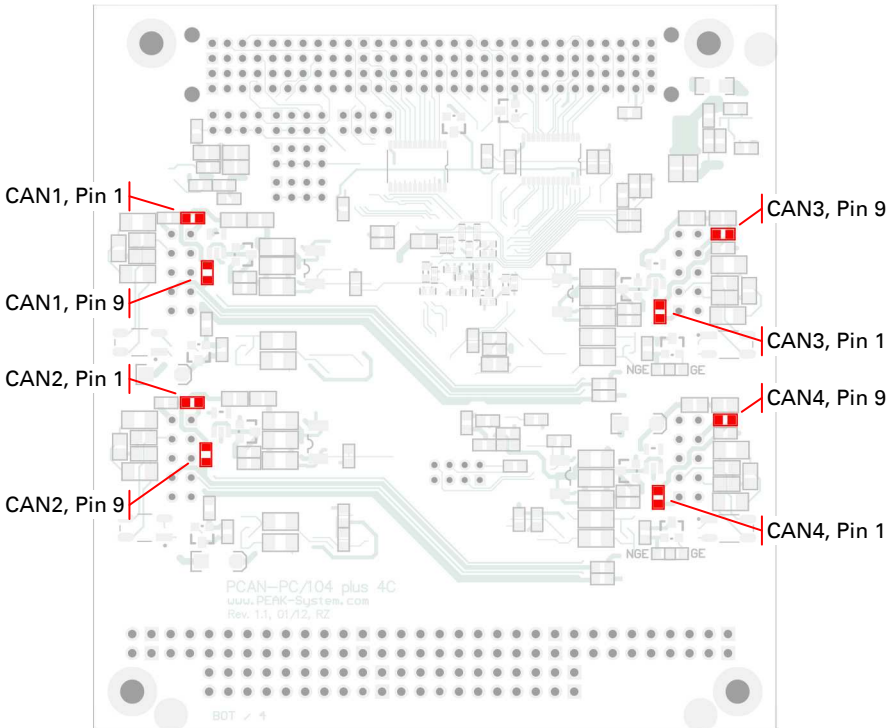

Figure 5: Positions of the solder fields on the board's bottom side for a 5-Volt supply at the CAN connection (D-Sub)



**Attention! Risk of short circuit!** If the option described in this section is activated, you may only connect or disconnect CAN cables or peripheral systems (e.g. bus converters) to or from the PCAN-PC/104-Plus Quad card while the computer is de-energized.

## 3.3 Cabling

### 3.3.1 Termination

A High-speed CAN bus (ISO 11898-2) must be terminated on both ends with 120 Ohms. Otherwise, there are interfering signal reflections and the transceivers of the connected CAN nodes (CAN-interface, control unit) will not work.

The PCAN-PC/104-Plus Quad card does not have an internal termination. Use the card on a terminated CAN bus.

### 3.3.2 Example of a Connection

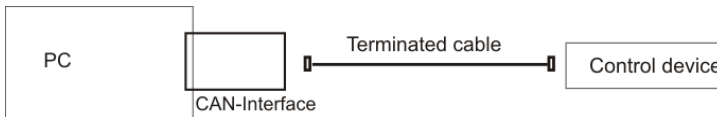

Figure 6: Simple CAN connection

In this example, the PCAN-PC/104-Plus Quad card is connected with a control unit by a cable that is terminated at both ends.

### 3.3.3 Maximum Bus Length

High-Speed-CAN networks may have bit rates of up to 1 Mbit/s. The maximum bus length depends primarily on the bit rate.

The following table shows the maximum possible CAN bus length at different bit rates:

Bit rate	Bus length
1 Mbit/s	40 m
500 kbit/s	110 m
250 kbit/s	240 m
125 kbit/s	500 m
50 kbit/s	1.3 km
20 kbit/s	3.3 km
10 kbit/s	6.6 km
5 kbit/s	13.0 km

The listed values have been calculated on the basis of an idealized system and can differ from reality.

## 4 Using the Software

This chapter covers the provided software PCAN-View and the programming interface PCAN-Basic.

### 4.1 CAN Monitor PCAN-View for windows

PCAN-View for Windows is a simple CAN monitor for viewing, transmitting, and logging CAN messages.

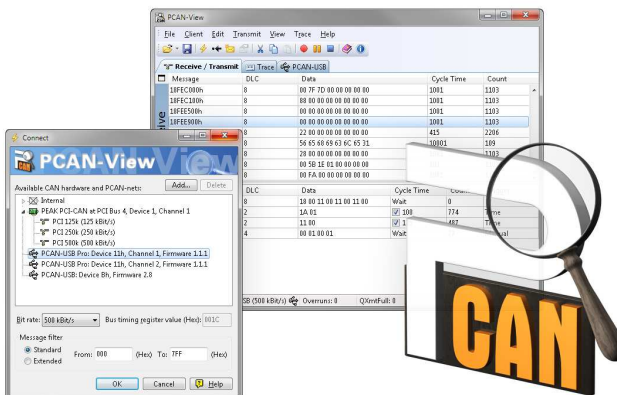

Figure 7: PCAN-View for Windows

▶ Do the following to start and initialize PCAN-View:

1. If PCAN-View is already installed on the hard disk, open the Windows Start menu, go to **Programs > PCAN-Hardware**, and select the entry **PCAN-View**.

If you haven't installed PCAN-View together with the device driver, you can start the program directly from the supplied DVD. In the DVD navigation program (`Intro.exe`), go to **English > Tools**, and under **PCAN-View for Windows** select the link **Start**.

The dialog box for selecting the CAN hardware and for setting the CAN parameters appears.

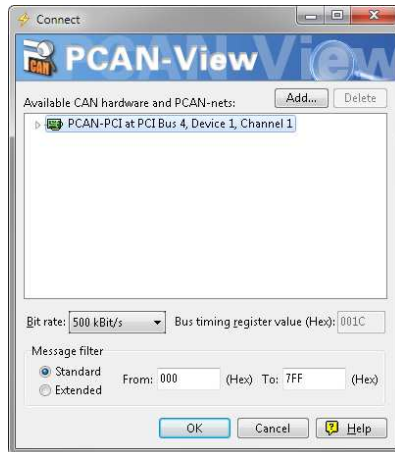
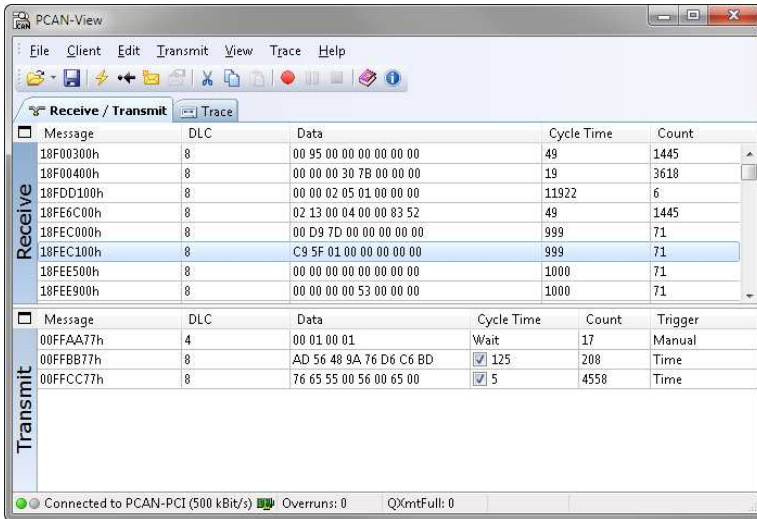

Figure 8: Selection of the CAN hardware and parameters

2. From the list **Available CAN hardware** select the CAN channel to be used.
3. Select the bit rate that is used by all nodes on the CAN bus from the dropdown list **Bit rate**.
4. Under **Filter settings** you can limit the range of CAN IDs to be received, either for standard frames (11-bit IDs) or for extended frames (29-bit IDs).
5. Finally confirm the settings in the dialog box with **OK**. The main window of PCAN-View appears (see Figure 9).

### 4.1.1 Receive/Transmit Tab



Message	DLC	Data	Cycle Time	Count
18F00300h	8	00 95 00 00 00 00 00 00	49	1445
18F00400h	8	00 00 00 30 7B 00 00 00	19	3618
18FDD100h	8	00 00 02 05 01 00 00 00	11922	6
18FE6C00h	8	02 13 00 04 00 00 83 52	49	1445
18FEC000h	8	00 D9 7D 00 00 00 00 00	999	71
18FEC100h	8	C9 5F 01 00 00 00 00 00	999	71
18FEE500h	8	00 00 00 00 00 00 00 00	1000	71
18FEE900h	8	00 00 00 00 53 00 00 00	1000	71

  

Message	DLC	Data	Cycle Time	Count	Trigger
00FFAA77h	4	00 01 00 01	Wait	17	Manual
00FFBB77h	8	AD 56 48 9A 76 D6 C6 BD	<input checked="" type="checkbox"/> 125	208	Time
00FFCC77h	8	76 65 55 00 56 00 65 00	<input checked="" type="checkbox"/> 5	4558	Time

Figure 9: Receive/Transmit tab

The Receive/Transmit tab is the main element of PCAN-View. It contains two lists, one for received messages and one for the transmit messages. Representation of CAN data is in hexadecimal format.

▶ Do the following to transmit a CAN message with PCAN-View:

1. Select the menu command **Transmit > New Message** (alternatively  or **Ins**).

The dialog box **New Transmit Message** is shown.

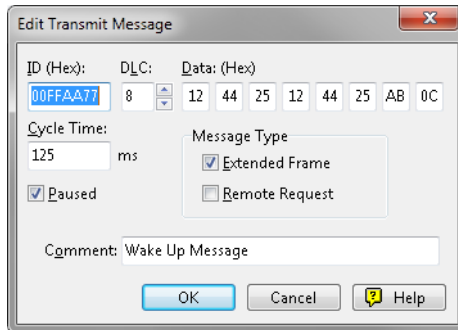

Figure 10: Dialog box New transmit message

2. Enter the ID and the data for the new CAN message.
3. The field **Cycle Time** indicates if the message shall be transmitted manually or periodically. If you want to transmit the message periodically, you must enter a value greater than 0. For a manual-only transmission enter 0.
4. Confirm the entries with OK.

The created transmit message appears on the **Receive/Transmit** tab.

5. You trigger selected transmit messages manually with the menu command **Transmit > Send** (alternatively `Space` bar). The manual transmission for CAN messages being transmitted periodically is carried out additionally.



**Tip:** By using the menu command **File > Save**, you can save the current transmit messages to a list and load them for reuse later on.

## 4.1.2 Trace Tab

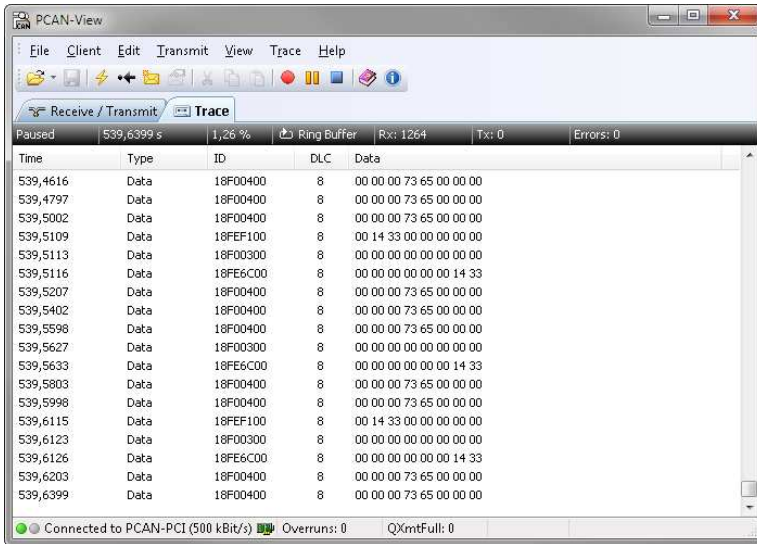

Figure 11: Trace tab

On the Trace tab the data tracer of PCAN-View is used for logging the communication on a CAN bus. During this process the CAN messages are cached in the working memory of the PC. Afterwards they can be saved to a file.

The tracer can be configured to run in linear or in ring buffer mode. In linear buffer mode the logging is stopped as soon as the buffer is filled completely. In ring buffer mode the oldest messages are overwritten by incoming ones.

### 4.1.3 Status Bar



Figure 12: Example for the status bar

The status bar shows information about the current CAN connection, about error counters (Overruns, QXmtFull), and shows error messages.

You can find further information about the use of PCAN-View in the help which you can invoke in the program via the menu **Help** or the **F1** key.

## 4.2 Linking Own Programs with PCAN-Basic

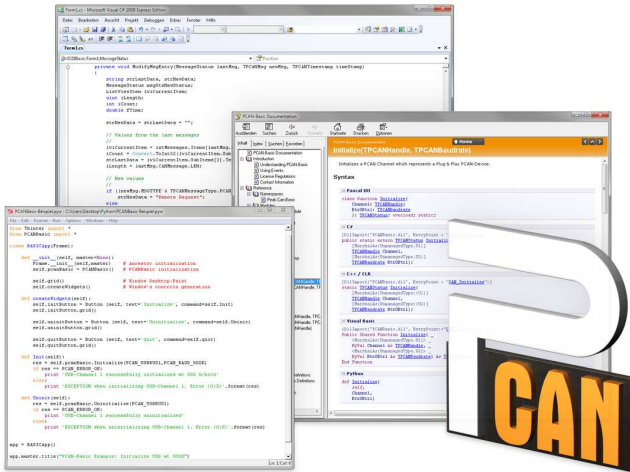

Figure 13: PCAN-Basic

On the provided DVD you can find files of the programming interface PCAN-Basic in the directory branch `Develop`. This API provides basic functions for linking own programs to CAN interfaces by PEAK-System and can be used for the following operating systems:

- └ Windows 7/Vista/XP (32/64-bit)
- └ Windows CE 6.x (x86/ARMv4)

The API is designed for cross-platform use. Therefore software projects can easily be ported between platforms with low efforts. PEAK-System has created examples for the following programming languages: C++, C#, C++/CLR, Visual Basic, Delphi, Python, and Java.

### 4.2.1 Features of PCAN-Basic

- └ Supports Windows 7/Vista/XP (32/64-bit) and Windows CE 6.x operating system
- └ Multiple PEAK-System applications and your own can be operated on a physical CAN channel at the same time
- └ Use of a single DLL for all supported hardware types
- └ Use of up to 8 channels for each hardware unit (depending on the PEAK CAN interface used)
- └ Simple switching between channels of a PEAK CAN interface
- └ Driver-internal buffering of 32,768 messages per CAN channel
- └ Precision of time stamps on received messages up to 1  $\mu$ s (depending on the PEAK CAN interface used)
- └ Access to specific hardware parameters, such as listen-only mode
- └ Notification of the application through Windows events when a message is received
- └ Extended system for debugging operations
- └ Multilingual debugging output
- └ Output language depends on operating system
- └ Debugging information can be defined individually

An overview of the API functions is located in the header files. You can find detailed information about the PCAN-Basic API on the provided DVD in the text and help files (file name extensions `.txt` and `.chm`).

## 4.2.2 Principle Description of the API

The PCAN-Basic API is the interface between the user application and device driver. In Windows operating systems this is a DLL (Dynamic Link Library).

The sequence of accessing the CAN interface is divided into three phases:

1. Initialization
2. Interaction
3. Completion

### Initialization

A CAN channel must be initialized before using it. This is done by the simple call of the `CAN_Initialize` function. Depending on the type of the CAN hardware, up to eight CAN channels can be opened at the same time. After a successful initialization the CAN channel is ready for communication with the CAN hardware and the CAN bus. No further configuration steps are required.

### Interaction

For receiving and transmitting CAN messages the functions `CAN_Read` and `CAN_Write` are available. Additional settings can be made, e.g. setting up message filters to confine to specific CAN IDs or setting the CAN controller to listen-only mode.

When receiving CAN messages, events are used for an automatic notification of an application (client). This offers the following advantages:

- The application no longer needs to check for received messages periodically (no polling).
- The response time at reception is reduced.

## Completion

To end the communication the `CAN_Uninitialize` function is called in order to release the reserved resources for the CAN channel, among others. In addition the CAN channel is marked as “Free” and is available to other applications.

### 4.2.3 Notes about the License

Device drivers, the interface DLL, and further files needed for linking are property of the PEAK-System Technik GmbH and may be used only in connection with a hardware component purchased from PEAK-System or one of its partners. If a CAN hardware component of third-party suppliers should be compatible to one of PEAK-System, then you are not allowed to use or to pass on the driver software of PEAK-System.

If a third-party supplier develops software based on the PCAN-Basic and problems occur during the use of this software, consult the software provider.

## 5 Technical specifications PCAN-PC/104-Plus Quad

### Connectors

PC/104-Plus	PCI bus (PC/104-Plus Version 2), 120-pin strip, for 5-Volt systems ISA bus: optionally equipped stack-through connectors for the ISA signals
4 High-speed CAN	D-Sub (m), 9 pins Pin assignment according to specification CiA® 102

### CAN

Specification	ISO 11898-2; High-speed CAN 2.0A (standard format) and 2.0B (extended format)
Bit rates	5 kbit/s - 1 Mbit/s
Controller	NXP SJA1000-compatible (FPGA implementation)
Transceiver	NXP PCA82C251
Galvanic isolation	Up to 500 V, separate for each CAN channel
Supplying external devices	D-Sub pin1 / 9; 5 V, max. 100mA Not assigned at delivery
Termination	None

### Supply

Supply voltage	5 V DC
Current consumption	max. 300 mA

### Measures

Dimension	about 90 x 96 x 15 mm; (stacking height; component height max. 11 mm) See also dimension drawing in Appendix B on page 32
Weight	56 g

Continued on the next page

**Environment**

Operating temperature	-40 – +85 °C (-40 – +185 °F)
Temperature for storage and transport	-40 – +125 °C (-40 – +257 °F)
Relative humidity	15 – 90 %, not condensing
EMC	EN 55024:2003-10 EN 55022:2008-05 EC directive 2004/108/EG

# Appendix A CE Certificate

PCAN-PC/104-Plus Quad IPEH-002099 – EC Declaration of Conformity  
PEAK-System Technik GmbH



## Notes on the CE Symbol

The following applies to the PCAN-PC/104-Plus Quad products IPEH-002099

### EC Directive

This product fulfills the requirements of EC directive 2004/108/EG on "Electromagnetic Compatibility" and is designed for the following fields of application as per the CE marking:

### Electromagnetic Immunity

DIN EN 55024, Publication date: 2003-10  
Information technology equipment, immunity characteristics – Limits and methods of measurement (IEC/CISPR 24:1997, modified + A1:2001 + A2:2003);  
German version EN 55024:1998 + A1:2001 + A2:2003

### Electromagnetic Emission

DIN EN 55022, Publication date: 2008-05  
Information technology equipment – Radio disturbance characteristics – Limits and methods of measurement (IEC/CISPR 22:2005, modified + A1:2005);  
German version EN 55022:2006 + A1:2007

### Declarations of Conformity

In accordance with the above mentioned EU directives, the EC declarations of conformity and the associated documentation are held at the disposal of the competent authorities at the address below:

#### PEAK-System Technik GmbH

Mr. Wilhelm  
Otto-Roehm-Strasse 69  
64293 Darmstadt  
Germany

Phone: +49 (0)6151 8173-20  
Fax: +49 (0)6151 8173-29  
E-mail: [info@peak-system.com](mailto:info@peak-system.com)



Signed this 15<sup>th</sup> day of December 2011

## Appendix B Dimension Drawing

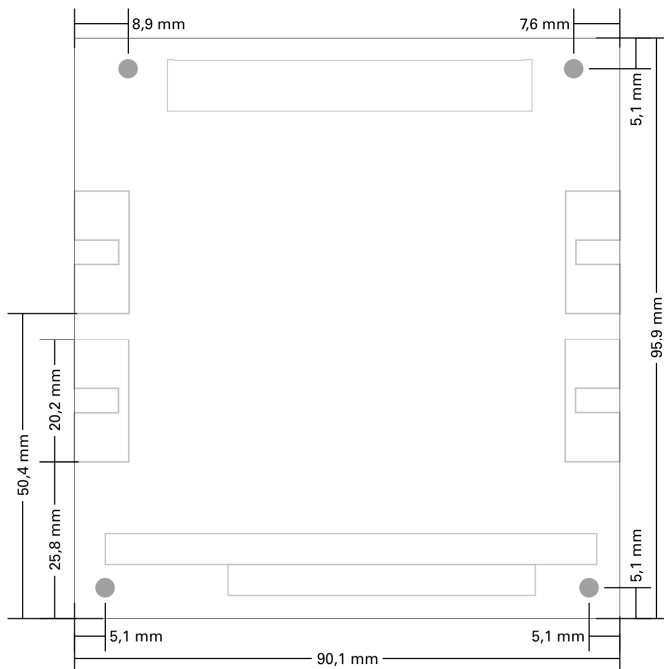

Figure 14: Dimension drawing PCAN-PC/104-Plus Quad.

The figure doesn't show the actual size of the product.

## Appendix C Quick Reference

### Card Configuration

Jumper	Signal	Position in the PC/104 stack in relation to the host			
		1	2	3	4
IDx	ID Select	0	1	2	3
CLKx	Clock Select	0	1	2	3
INTx	Interrupt Select	0	1	2	3

### Software/Hardware Installation under windows

Before installing the PCAN-PC/104-Plus Quad card in the PC/104 stack, setup the corresponding software package from the supplied DVD (with Administrator privileges). The card is recognized by Windows and the driver is initialized. After the installation process is finished successfully you can find the entry "PCAN-PC/104-Plus" in the branch "CAN-Hardware" of the Windows Device Manager.

### Getting started under windows

Run the CAN monitor PCAN-View from the Windows Start menu as a sample application for accessing the PCAN-PC/104-Plus Quad card. For initialization of the card select the CAN connection and the CAN bit rate.

### High-speed CAN connector (D-Sub, 9 pins)

