

1 FEATURES

- Low voltage operation down to 1 volt
- Low component count circuit
- Adjustable power output with current setting resistor
- External enable input
- High efficiency
- Internal oscillator timing
- Available in five pin small outline (SOT23-5) package

2 GENERAL DESCRIPTION

The OM5448 is a low voltage bipolar integrated circuit operational down to 1 volt. It boosts the available supply voltage to enable it to drive an LED (light emitting diode) or other load. Its design arises from over 20 years of IES experience in the design and manufacture of LED drive integrated circuits for use in warning lamps.

Its most important characteristic is its ability to provide LED drive from a single or dual cell battery providing higher DC voltages for special applications, or a sufficient boosted

voltage to overcome the higher voltage required to drive an LED.

Using an external choke to provide the voltage boost, the flyback voltage on the choke can be used directly to drive the LED in pulsed mode, or rectified to give a DC voltage LED drive or power supply output by using a diode and capacitor.

While the OM5448 output (OP) is ON the current in the choke increases. It is held low until it reaches an internal current level threshold set by a resistor from the SETI pin to VEE. The output drive then switches OFF for a period set internally in the OM5448. At the end of this time OP is switched ON again.

The enable input provides an electronic control to disable the OM5448 output, when pulled low it switches the OM5448 into a low current standby mode.

It can drive a single LED or multiple LEDs in series and/or parallel up to a maximum voltage on OP of 14 volts. The peak output voltage is also limited to 14 volts when used in the voltage boost application.

3 BLOCK DIAGRAM

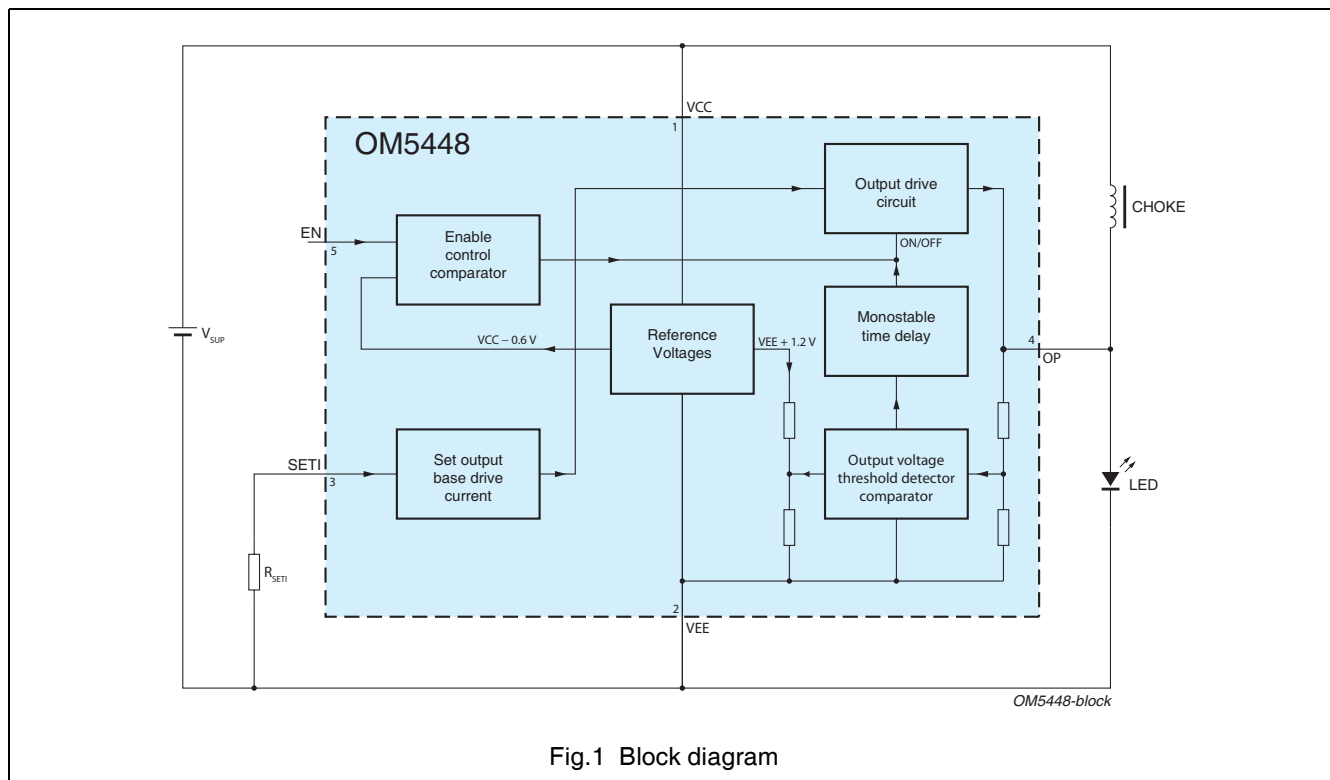
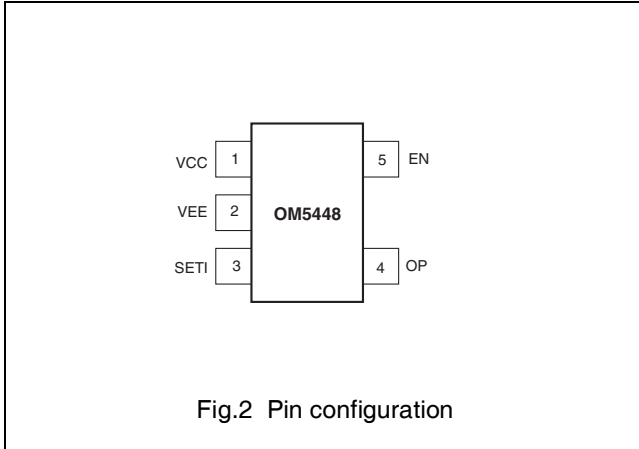

Fig.1 Block diagram

4 PINNING INFORMATION

4.1 Pinning layout



4.2 Pin description

SYMBOL	PIN	DESCRIPTION
VCC	1	Positive supply
VEE	2	Negative supply
SETI	3	Set output trip current
OP	4	Output drive, active low
EN	5	Enable, active high

5 QUICK REFERENCE DATA

Unless otherwise specified all voltages are specified with respect to V_{EE} .

operating input supply voltage range	V_{sup}	1 to 3.5 V
maximum output voltage (peak)	V_{OPmax}	14 V
maximum output load current (average)	I_{outavg}	250 mA
maximum output current (peak)	I_{outmax}	500 mA
supply current in active mode (OP high, OFF)	I_{active}	700 μ A typ.
supply current in active mode (OP low, ON)	I_{active}	1.7 mA typ
supply current in standby mode	I_{stb}	700 μ A typ.
oscillation frequency	F_{OP}	80 kHz typ.
enable threshold voltage (referred to VCC)	V_{EN}	-590 mV
total power dissipation	P_{tot}	200 mW max
operating ambient temperature range	T_{amb}	-40 to +85 °C
maximum operating junction temperature	T_{jmax}	150 °C

6 FUNCTIONAL DESCRIPTION

6.1 OM5448 function

The OM5448 is an inductive boost converter IC designed to operate to a very low voltage. Using a bipolar process, it will operate down to a supply voltage of 1 volt, making it suitable for use from a single 1.2 volt rechargeable battery.

It operates by switching ON an NPN output drive transistor which is in series with a choke between V_{CC} and V_{EE} . When the output transistor is switched ON, the current flowing in the choke increases at a rate determined by the voltage across the choke and its inductance.

Incorporated in the OM5448 is a threshold detector monitoring the collector voltage of the output transistor. The base drive current of the output transistor is limited and as the transistor becomes base current starved and it pulls out of saturation the collector voltage starts to rise towards the internally set switching threshold.

When the collector voltage reaches this threshold, the base drive is switched OFF, open circuiting the OP transistor. The current flowing in the inductance of the choke acts to ensure that the saturation current flowing at that time continues to flow, and raises the collector voltage on the transistor.

The collector voltage must not be allowed to increase to the maximum rated output voltage, and is usually caught by the load circuit at a voltage more positive than V_{CC} . For example the load in the most simple circuit can be LED diodes having a forward conduction voltage greater than the available battery voltage but less than the maximum voltage permitted on OP.

In the OM5448 the OFF time is fixed internally in the IC chip, and after this time has elapsed the output drive is turned ON again, allowing the inductance current to increase again towards the threshold.

Depending on the external components used (current setting resistor, choke inductance, and choke resistance) the OM5448 inverter may operate either with the choke current falling to zero before the internally generated OFF period has elapsed, or in the mode where the current does not fall to zero before OP is again switched ON and is pulled low. In this second mode the choke current is modulated between the peak switching threshold set by the SETI resistor, and the current level to which it has fallen at the end of the internally set OFF period.

6.2 Voltage reference

A voltage reference circuit in the OM5448 offers a voltage clamped to 1.2 volts to provide a reference for two purposes: first is to give a stable reference for the output collector threshold detector. The 1.2 V reference is divided in a resistive voltage divider to give a reference of 150 mV for the collector saturation voltage threshold comparator.

The second use of the reference provides a V_{BE} voltage of about 0.6 volts below V_{CC} to set the threshold of the enable comparator.

If the battery voltage V_{CC} is less than 1.2 V it the reference follows V_{CC} . When V_{CC} is greater than 1.2 volts it is clamped to 1.2 V.

6.3 Enable input (EN pin)

The enable control comparator has a small constant current pull-up source driving the EN pin; so that if this pin is not connected it is pulled high, and

the OM5448 is active. EN can also be connected to V_{CC} .

If it is pulled low, for example by connecting it to V_{EE} , the OM5448 is inactive, and the output is held switched off.

The EN pin can be also used in an active control circuit to close a regulating loop, offering a controlled output voltage or current.

6.4 Set output current threshold (SETI pin)

The base drive to the output transistor is set by a resistor connected from the SETI pin to VEE. This resistor can be varied over a wide range to allow the output power to be adjusted to suit the intended load.

6.5 Saturation voltage threshold detector

A long tailed pair comparator monitors the collector voltage of the output transistor. The saturation voltage of the transistor is divided by a resistor network so that when the collector voltage reaches the desired $V_{CE(sat)}$ voltage of 450 mV, the voltage at the comparator input is reduced to typically 150 mV.

This overcomes the problem that without this divider, the sum obtained by adding the saturation voltage of the output transistor voltage to the voltage of the long-tail comparator's emitter current source (100 mV) plus its V_{BE} for the comparator input transistor (600 mV) giving a total of 1.15 volts; well above the required 1 volt target minimum operating voltage for single cell rechargeable operation. By dividing the saturation voltage to 150 mV the total is reduced to 850 mV, and 1 volt performance is assured.

The temperature coefficient of the V_{BE} also demands an adequate

voltage margin to ensure proper operation at low temperatures.

6.6 Monostable time delay

When the $V_{CE(SAT)}$ trip level of the output transistor is reached, and ON/OFF latch is switch to its OFF state. This initiates a time delay by applying the turn-OFF switching edge to a series string of injection logic gates (integrated injection logic, I²L). When the OFF transition reaches the end of this series string of gates (the sum of the gate delays) it resets the ON/OFF latch, and turns ON the drive to the output transistor again.

6.7 Output drive transistor

The output drive transistor has been designed to have a low saturation voltage and high current gain. For most of the ON time it is well in saturation with only a low voltage drop lost across the transistor. Towards the end of the conduction

part of the cycle when it pulls out of saturation, the voltage rises quickly with the increasing current minimising this inefficient part of its operating cycle. It is possible to obtain efficient performance from the OM5448 output circuit and its chosen switching threshold.

6.8 Choke selection: Efficiency

The optimum choke inductance for the OM5448 has been found to be 220 μ H. This offers the best balance between cost and performance. In addition to the optimum value of the inductance, the core must not saturate at the peak current. Also the winding resistance can add significantly to the energy losses, and therefore for the best efficiency of the circuit the choke resistance needs to be minimised.

Simple calculations indicate that some of the source of losses in the OM5448 circuit can be identified. For

example, operating from a 1.2 volt battery an average conduction time saturation voltage of 60 mV across the output transistor will lose 5% of the battery voltage (and hence energy) in the transistor.

In addition a peak current of 200 mA and a coil resistance of 1.6 Ohms means that a further 320 mV of battery voltage is effectively lost.

If an LED is driven with an average current of 20 mA, with a peak current of 50 mA, the peak voltage loss across the inductor's effective resistance is 80 mV, and of a comparable order of magnitude to the transistor losses.

A further source of losses arises from any internal series resistance provided by the power supply and the load. For example, the effective series resistance of a power supply filter capacitor can offer a significant loss of efficiency: a low effective series resistance capacitor is needed.

7 LIMITING VALUES

In accordance with the Absolute Maximum Rating System (IEC 134).

All voltages are specified with respect to V_{EE} .

SYMBOL	PARAMETER	CONDITIONS	MIN.	MAX.	UNIT
V_{CC}	supply voltage		-0.5	3.5	V
I_{supply}	maximum current, V_{CC} pin	current in	-1	500	mA
V_{OP}	output voltage, OP pin		-0.5	14	V
I_{OP}	maximum current, OP pin	current in	-1	500	mA
V_{SETI}	input voltage, SETI pin		$V_{EE} - 0.5$	$V_{CC} + 0.5$	V
I_{SETI}	maximum current, SETI pin	current out	-1	50	mA
V_{EN}	input voltage, EN pin		$V_{EE} - 0.5$	$V_{CC} + 0.5$	V
I_{EN}	maximum current, EN pin		-1	1	mA
P_{tot}	total power dissipation		-	200	mW
T_{stg}	storage temperature		-40	+150	$^{\circ}$ C
T_{amb}	operating ambient temperature		-40	+85	$^{\circ}$ C
T_{jmax}	maximum junction temperature		-	+150	$^{\circ}$ C
R_{thj-a}	thermal resistance from junction to ambient	note 1	-	+500	deg K/W

Note

1. Mounted on an FR4 printed circuit board 8mm x 10mm x 0.7 mm.

8 CHARACTERISTICS

At $T_{amb} = 25^{\circ}\text{C}$; Voltages are specified with respect to V_{EE} (pin 2). Unless otherwise specified.

SYMBOL	PARAMETER	CONDITIONS	MIN	TYP	MAX	UNIT
Power supply						
V_{CC}	supply voltage (operating)		1	–	3.5	V
Supply current, V_{CC}, (pin 1)						
$I_{SUP(standby)}$	standby supply current	$V_{EN} = V_{EE}$	–	250	–	μA
$I_{SUP(run)}$	operating supply current	$V_{EN} = V_{CC} = 1.2\text{ V}$, $R_{SET1} = 4.7\text{ k}\Omega$, ($\sim 20\text{ mA } I_{OP}$)	–	700	–	μA
$I_{SUP(run)}$	operating supply current	$V_{EN} = V_{CC} = 2.4\text{ V}$, $R_{SET1} = 68\text{ k}\Omega$, ($\sim 20\text{ mA } I_{OP}$)	–	400	–	μA
Efficiency						
η	operating efficiency, see figure 4 for the circuit	$V_{CC} = 1.2\text{ V}$, $V_{OP} = 3.1\text{ V}$	–	70	–	%
		$V_{CC} = 2.4\text{ V}$, $V_{OP} = 3.1\text{ V}$	–	80	–	%
Output drive, OP (pin 4)						
$V_{OP(max)}$	output drive voltage maximum	Care must be taken that the flyback voltage on the output pin VP does not exceed $V_{OP(max)}$.	–	–	14	V
$V_{OP(sat)}$	output switching threshold (output transistor saturation voltage)	output drive current at which this threshold voltage is reached is set by choice of R_{SET1}	–	450	–	mV
F_{OP}	oscillator frequency	inductor = $220\text{ }\mu\text{H}$ ($R_S < 1.6\text{ }\Omega$)	–	80	–	kHz
Set peak output current, SET1 (pin 3)						
V_{SET1}	voltage on SET1 pin	$V_{CC} = 2.4\text{ V}$, $I_{OP} = 20\text{ mA}$ inductor = $220\text{ }\mu\text{H}$ ($R_S = 1.6\text{ }\Omega$), $R_{SET1} = 78\text{ k}\Omega$	–	$V_{CC} - 1\text{ V}$	–	V
		$V_{CC} = 2.4\text{ V}$, $I_{OP} = 250\text{ mA}$, inductor = $100\text{ }\mu\text{H}$ ($R_S = 0.09\text{ }\Omega$), $R_{SET1} = 78\text{ k}\Omega$	–	$V_{CC} - 2.15\text{ V}$	–	V
		$V_{CC} = 2.4\text{ V}$, $I_{OP} = 1.2\text{ mA}$, inductor = $220\text{ }\mu\text{H}$ ($R_S = 1.6\text{ }\Omega$), $R_{SET1} = 78\text{ k}\Omega$	–	$V_{CC} - 0.73\text{ V}$	–	V
Enable input, EN (pin 5)						
I_{EN}	pull-up current	$V_{EN} = 0\text{ V}$, $V_{CC} = 2.4\text{ V}$	1.5	2.5	4.0	μA
$-V_{EN}$	enable switching threshold	V_{EN} with respect to V_{CC} , $V_{CC} = 2.4\text{ V}$	–	–590	–	mV

9 APPLICATION INFORMATION

9.1 Circuit design considerations

A series of circuit examples are suggested. These offer a number of application ideas for use of the OM5448. They have been chosen to illustrate the different ways in which the OM5448 can be used, and show how different circuit options can be chosen to emphasise the useful possibilities of this low voltage circuit.

The first circuit is the simplest, using a single LED load driven by a pulsed forward current drive (without filtering) during the flyback OFF time of the OM5448. Care must be taken to ensure that the peak pulse current remains within the pulse current rating of the LED data sheet.

Different circuit features discussed include the following:

- Pulsed LED drive
- DC LED drive
- Multiple LEDs, in series or parallel
- Active control of the SET1 input
- Battery voltage compensation for LED current drive
- Simple boost power supply circuits
- Enable input control
- Regulated power supply
- Voltage multiplier circuit
- Regulated voltage multiplier

The OM5448 operation sees increasing current in the inductor while it is being driven during the ON period of the output drive. During the OFF time this same current flows into the load voltage with the inductive

effect generating the necessary voltage above the V_{CC} supply rail to drive the load. Thus a circuit used to drive a 2.4 volt load from a 1.2 volt supply will at a first approximation, have a duty cycle of 50% with equal times for the output ON and OFF.

If the load is increased to 4.8 volts, then the ON time becomes 75% of the cycle, and the OFF time 25%. Thus the proportion of the cycle time spent driving the output decreases as it is required to drive a higher output voltage.

In addition, this decreasing duty cycle implies that the output current available must decrease as the voltage is increased.

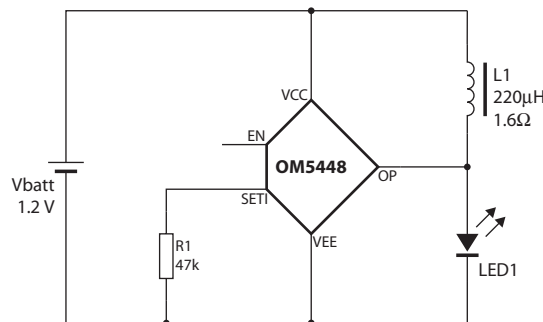

Fig.3 Simple pulse driven LED circuit

9.2 Simple pulse driven LED circuit

This application circuit in figure 3 has the lowest component count. In this circuit it is shown driving a single LED with pulsed current drive. When the output is ON, and pin OP is held low, the current increases through the choke L1 until the internally set current threshold is reached and the

OP transistor is turned OFF. The inductive action seeking to maintain the current flow in L1 raises the voltage on the junction of OP and the LED above the supply rail V_{CC} until there is sufficient voltage for the LED to conduct. Thus the current in the inductance continues to flow in the LED for a fixed period while OP is OFF. During this time the current falls

at a rate determined by the LED forward voltage plus the effective voltage drop in the inductor's resistance less the supply voltage.

As the LED current is pulsed, the peak current must remain below the maximum peak current rating of the LED. If ratings are exceeded the operational life of the LED may be threatened.

The value of the current setting resistor R1 must be chosen to give the required average LED current and hence brightness.

The required value of R1, and the operating duty cycle will change depending on the forward voltage drop of the LED. For example, 2.1 volt

amber LED will run with a longer conduction time each cycle when compared with a white LED with a typical forward voltage drop of 3.2 volts. For a similar average current the peak current in the white LED will be higher due to its lower duty cycle (shorter conduction time).

This circuit will also drive a white LED from a 2.4 volt supply.

Note that 2.4 volts is greater than the forward voltage of an amber LED, so the LED will already be conducting at the nominal battery voltage, and the circuit will not work.

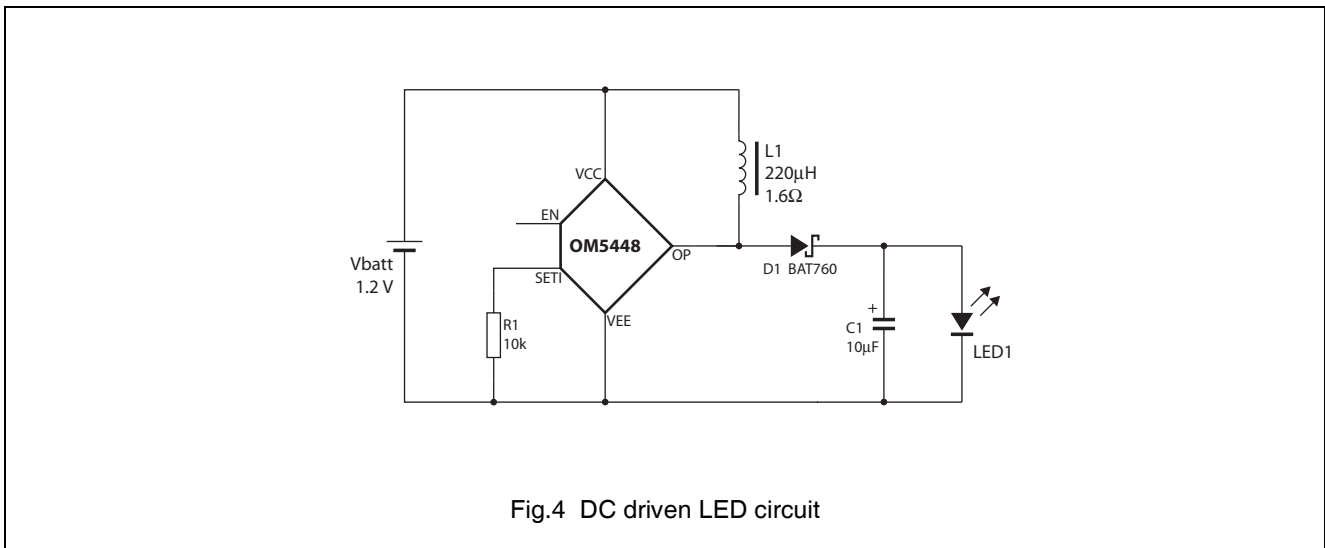

9.3 DC LED drive

The circuit shown in figure 4 adds a Schottky diode and filter capacitor to the previous circuit. The Schottky diode carries current when the voltage on the junction of pin OP, the inductor, and the anode of the Schottky diode is positive with respect to V_{CC} while OP is OFF. The inductor current flows through D1 to provide stored charge in filter capacitor C1.

Therefore the LED in this circuit is driven with a near DC current, and there are no problems with respect to its pulse rating being exceeded.

A normal small signal silicon diode can be used, but its increased forward voltage drop will result in lower circuit efficiency. As has been mentioned

elsewhere, the effective series resistance of capacitor C1 is also a factor in how efficiently the circuit will perform.

The value for R1 is chosen to give the target LED current at nominal operating voltage.

For example the component values shown in this circuit (figure 4) are for an amber LED carrying an average current of 20 mA.

To drive a white LED at 20 mA the value of R1 becomes 5.6 k.

If the battery voltage is increased to 2.4 volts, then the values of R1 needed for a 20 mA white LED drive becomes 82 kilohms. As 2.4 volts exceeds the sum of the forward

voltage of an amber LED and the forward voltage of the Schottky diode D1, at 2.4 volts this circuit is unsuitable for driving an amber LED.

9.3.1 PERFORMANCE GRAPHS FOR DC LED DRIVE, EFFICIENCY

In the following graphs, shown in figures 5, 6 and 7, efficiencies are compared for a number of variants of the circuit in figure 3 and figure 4. Efficiency is plotted for the average LED current x LED voltage at an equivalent DC current as a proportion of the input power (average input current x DC battery voltage).

The first two are for white LED drive, first (fig 5) in pulse mode, and the second (fig 6) in DC mode.

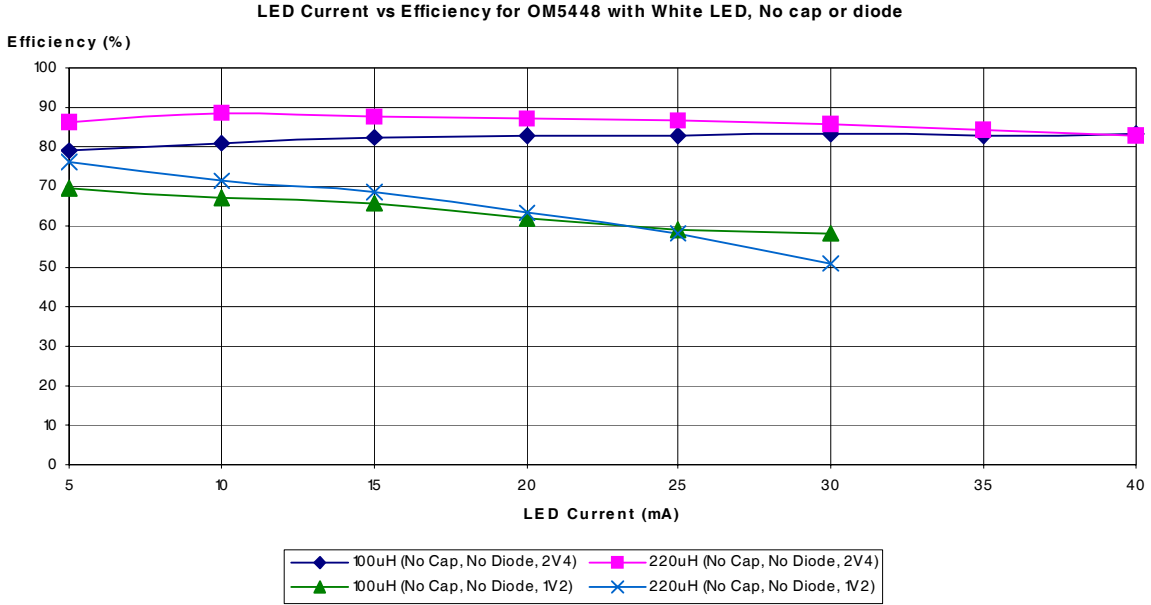

Fig.5 OM5448 efficiency when driving a white LED ($V_F = 3.1\text{ V}$ at 20 mA) in pulse mode. See figure 3. For 1.2 volt and 2.4 volt supply.

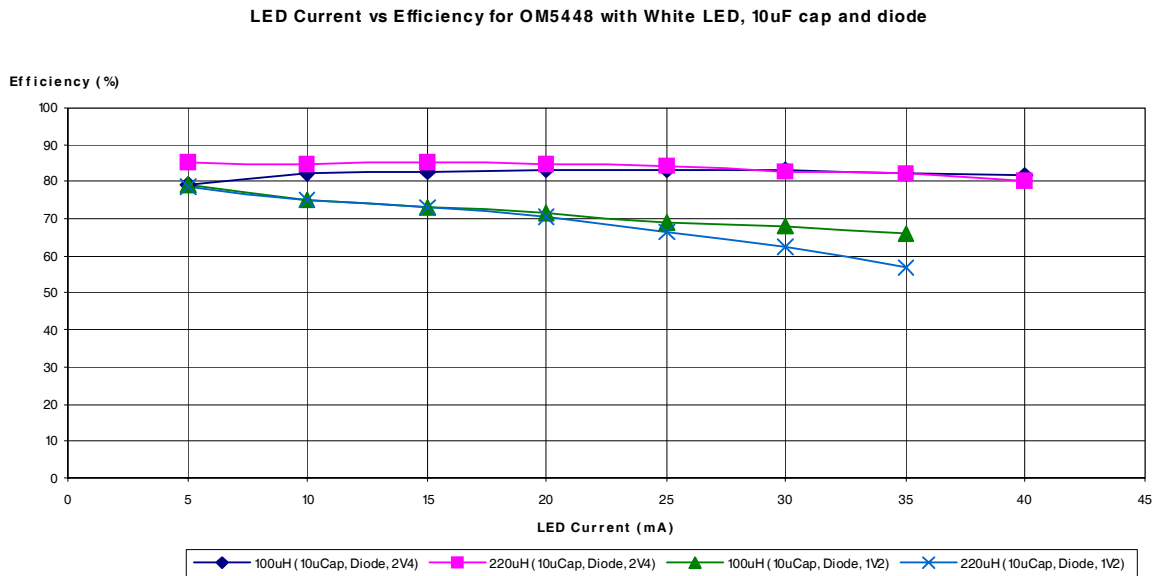
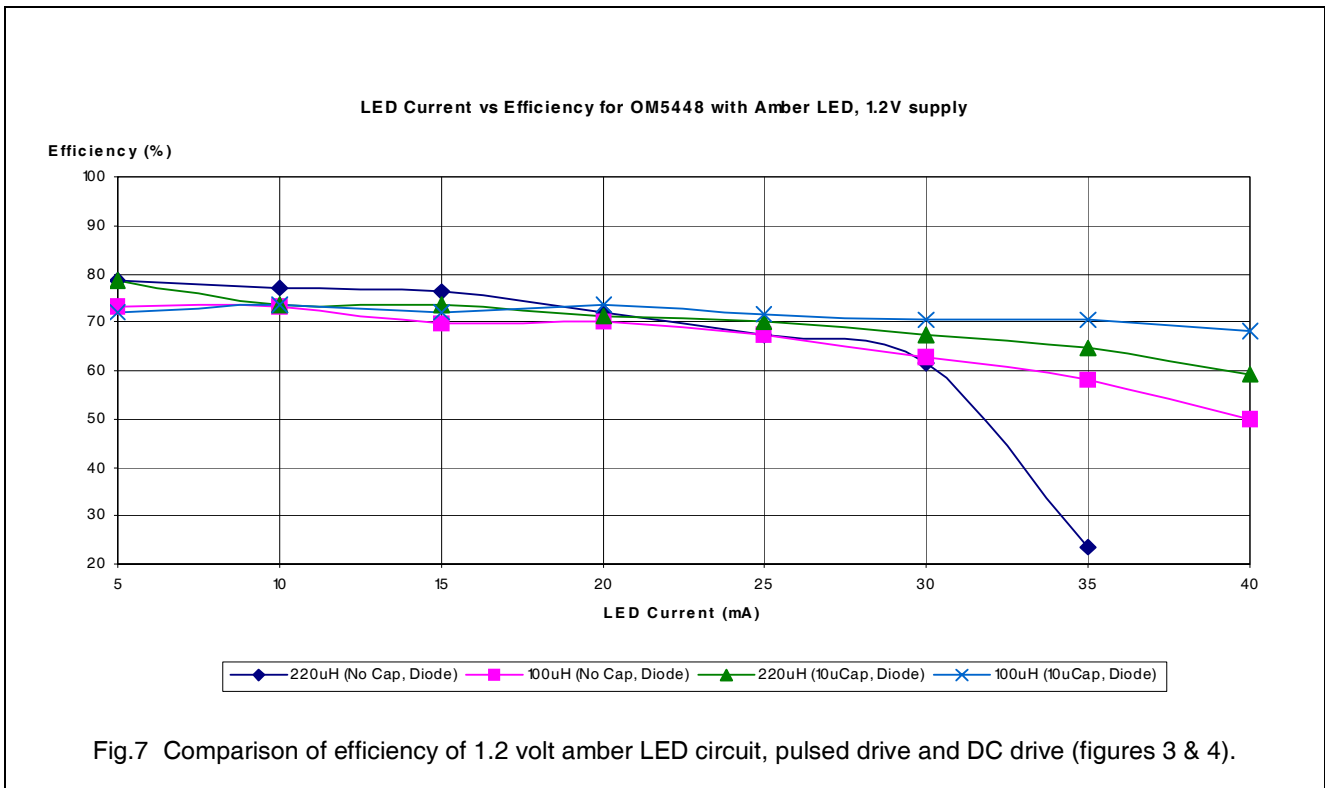

Fig.6 OM5448 efficiency when driving a white LED in DC mode. See figure 4. For 1.2 volt and 2.4 volt supply.

The third graph in figure 7 shows the efficiency against LED current for an amber LED. Both the pulsed circuit (figure 3) and the DC drive circuit (figure 4) are shown on this graph.

It should be noted that in the pulsed circuit the efficiency falls more quickly at high currents because of the relatively high resistance of the 220 μ H inductor.

As the typical forward voltage drop of an amber LED is 2.1 volts at 20 mA, and significant forward current flows at about 1.6 volts, the amber LED cannot be driven from a 2.4 volt supply.



9.3.2 SETI GRAPHS AGAINST LED CURRENT

The graphs in figures 8 and 9 show the value of the resistor R1 connected to the SETI pin in the DC LED drive circuit of figure 4.

As can be seen for the graphs, the choice of LED current and colour set the output power, and therefore all factors which contribute to losses (and thus efficiency) will need to be compensated for in the choice of R1 (R_{SETI}) for that given output

requirement. Thus each possible inductor value (and series resistance) and power supply voltage will result in a different R_{SETI} vs LED current curve.

9.4 Switched LED brightness

The circuit in figure 10 is able to be switched between two levels of LED brightness. By using switch SW1 on the SETI pin with a second current setting resistor R2, actuation of the

switch changes the set current and hence the brightness.

Other ideas might be suggested for setting brightness: for example use of a potentiometer in series with a fixed resistor will offer continuously variable light levels between a minimum and maximum figure.

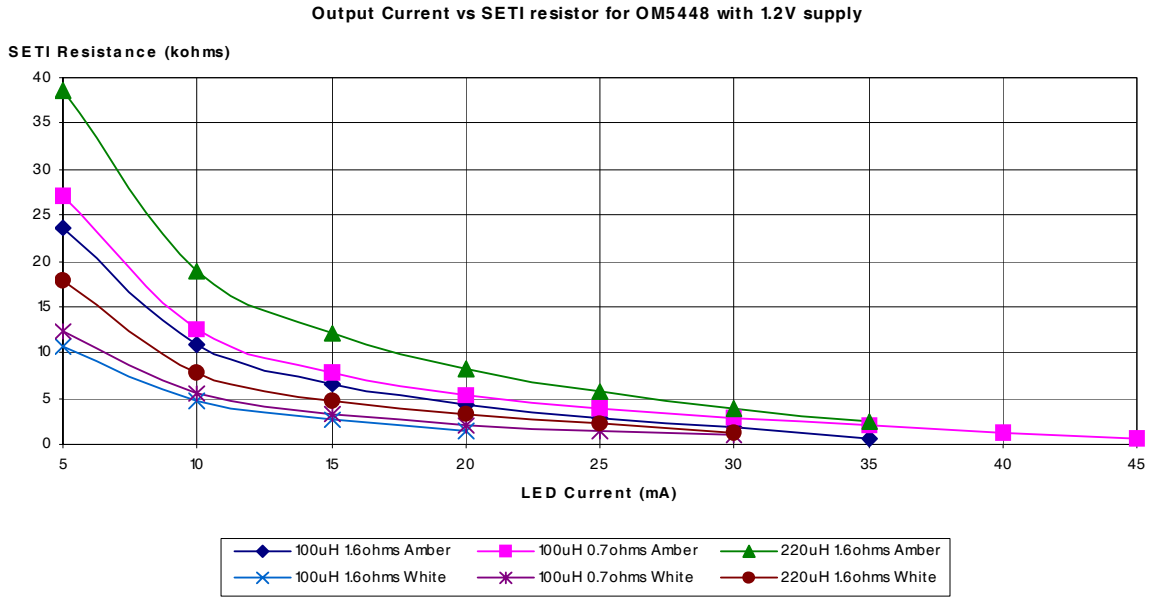

Fig.8 SETI resistance against LED current for both amber and white LEDs (1.2 V, circuit figure 4).

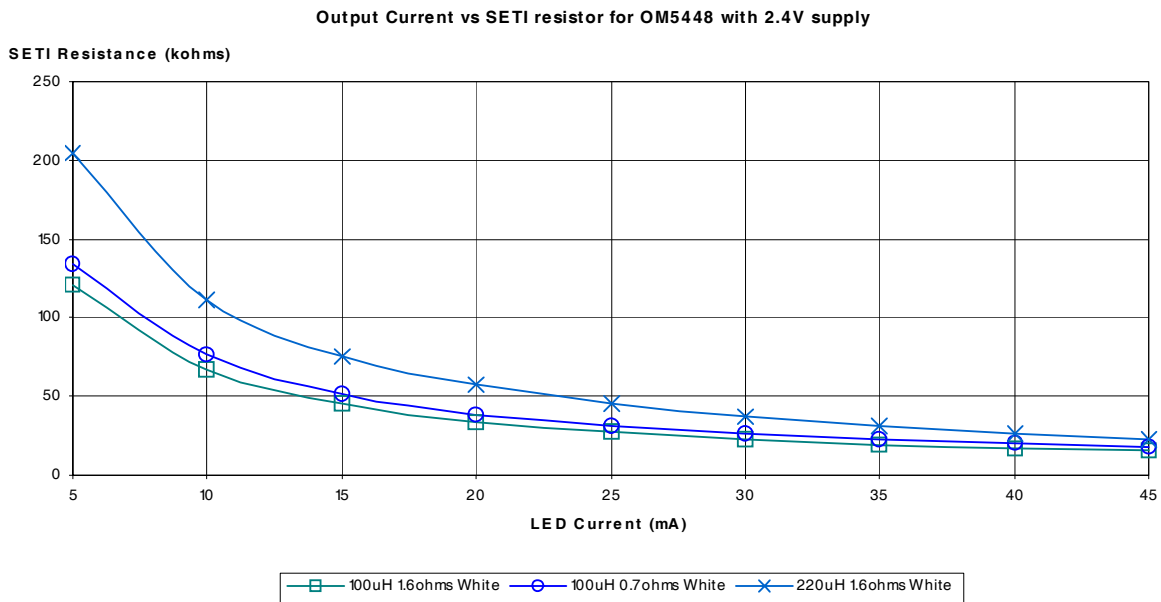

Fig.9 SETI resistance against LED current for a white LED (2.4 V, circuit figure 4).

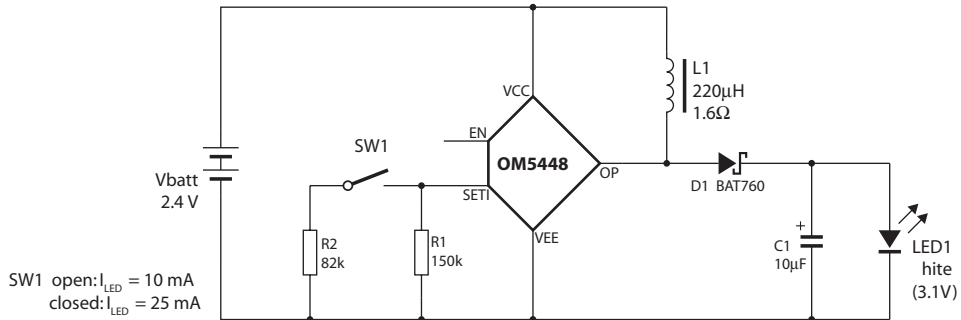

Fig.10 OM5448 LED drive circuit with switched light level using the R_{SETI} input.

9.5 Series and parallel LED connection

Earlier application circuits have shown single LED drive. However the OM5448 is also suitable for driving multiple LEDs in either series or

parallel connection. Figure 11 shows the OM5448 driving four LEDs in a series/parallel combination.

With parallel connection, current sharing can be forced by including a small series resistor with each LED

(see figure 12), but in this circuit below it has been found that the slope of current vs voltage for the forward biased LED ensures sufficient matching of the parallel LEDs for the intended application.

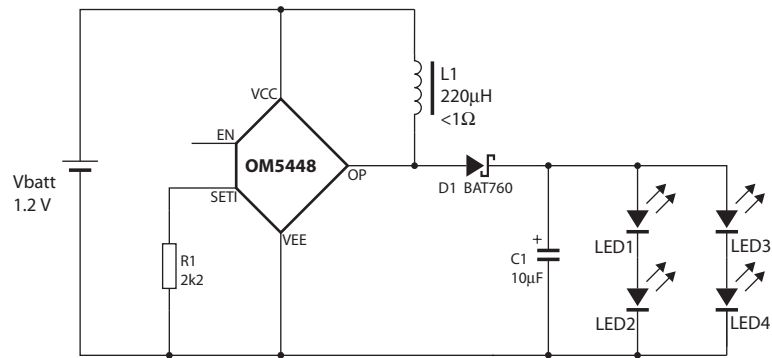

Fig.11 Series and parallel LED drive using the OM5448

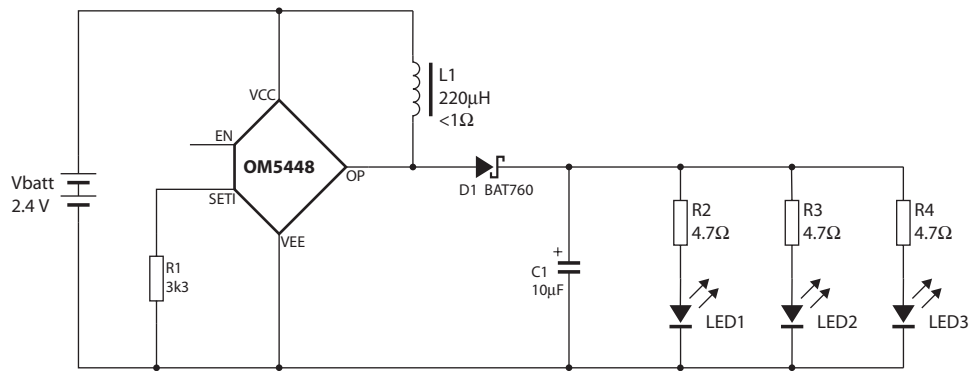

Fig.12 Parallel LED drive using the OM5448 (with current sharing resistors).

In figure 12 4.7 ohm resistors have been used in series with each of the three parallel LEDs to force current sharing. At 20 mA the voltage drop across the resistors will be approximately 100 mV.

Series LED connection is shown in figure 13. Three series LEDs have been shown, although a larger number can be driven up to the maximum voltage allowed on V_{OP} (14 V).

As the output voltage increases, the output drive part of each cycle becomes shorter, and the output drive duty cycle falls. This needs higher peak currents in the inductor to maintain a sufficient average LED load current.

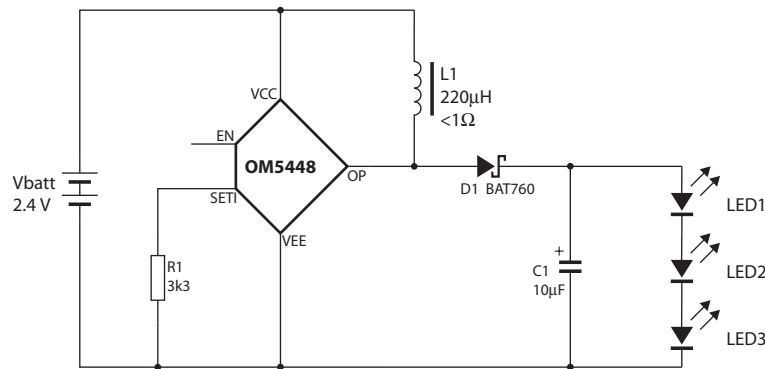

Fig.13 Series LED drive using the OM5448

9.6 Supply voltage sensitivity

As the base drive to the output transistor in the OM5448 is set by the input current to the SET1 pin, the resulting LED current is therefore dependent on the voltage across the SET1 resistor R1.

The graph in figure 14 shows this dependence for a 1.2 volt circuit

driving a white and an amber LED using the DC drive circuit of figure 4. Each circuit was set to 20 mA LED current at 1.2 V, and then the variation of output current was plotted as the supply voltage was changed. Of course a real battery supply will not normally offer this wide variation in operating voltage.

A similar graph for a white LED operating at 2.4 volts is shown in the following graph, figure 16. This graph also includes a curve for a circuit in which the voltage sensitivity is compensated with a simple external circuit.

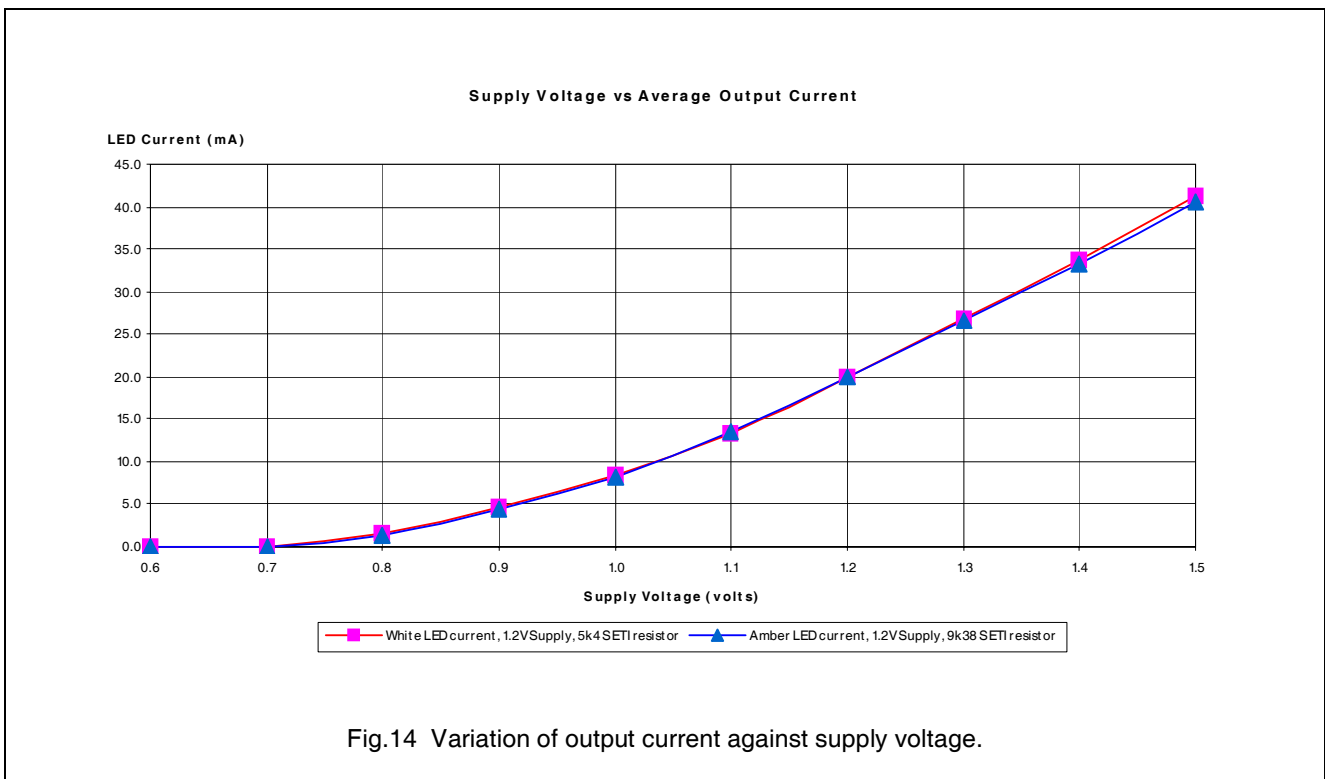

Fig.14 Variation of output current against supply voltage.

9.7 Compensation of output drive current against supply voltage variation

It is possible to use a simple active circuit external to the OM5448 connected to the SET1 pin to compensate for the variation in supply voltage.

The compensating circuit is shown in figure 15, giving the resulting graph in figure 16 in which the compensated and uncompensated LED current against supply voltage is compared

for a white LED set up for 20mA LED current from a 2.4 volt supply.

In this circuit a 1.2 volt reference is generated by the two series forward biased diode in D1a and D1b. This then applied to the base of TR1. The emitter of TR1 is connected to the junction of R1 and R2 which form a voltage divider from the supply voltage. This is equivalent to the divided voltage in series with a resistor to the emitter equal to the two resistors in parallel.

As the supply voltage varies, the input current to SET1 is almost equal to the current in this equivalent emitter resistor. This has been designed to track the variation in supply voltage and compensate so that the load current in the LED remains constant over the battery operating range.

As can be seen from figure 16, from 2.2 to 3 volts the LED current is nearly constant.

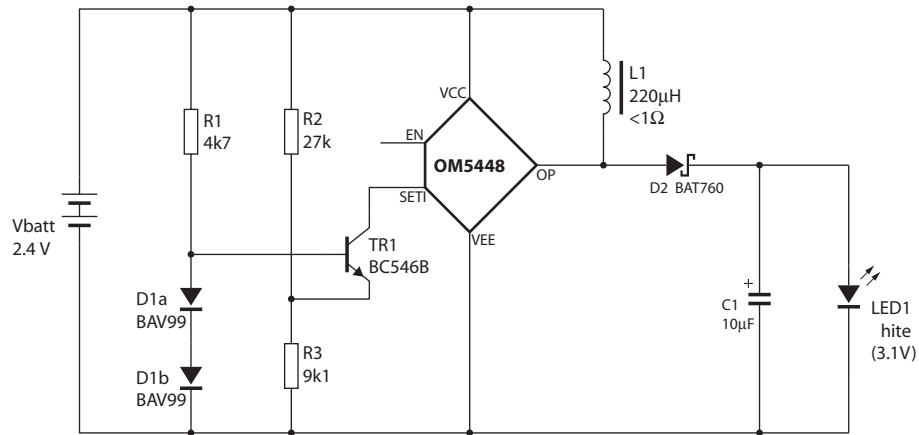

Fig.15 Simple stabilization circuit for LED current variation against supply voltage.

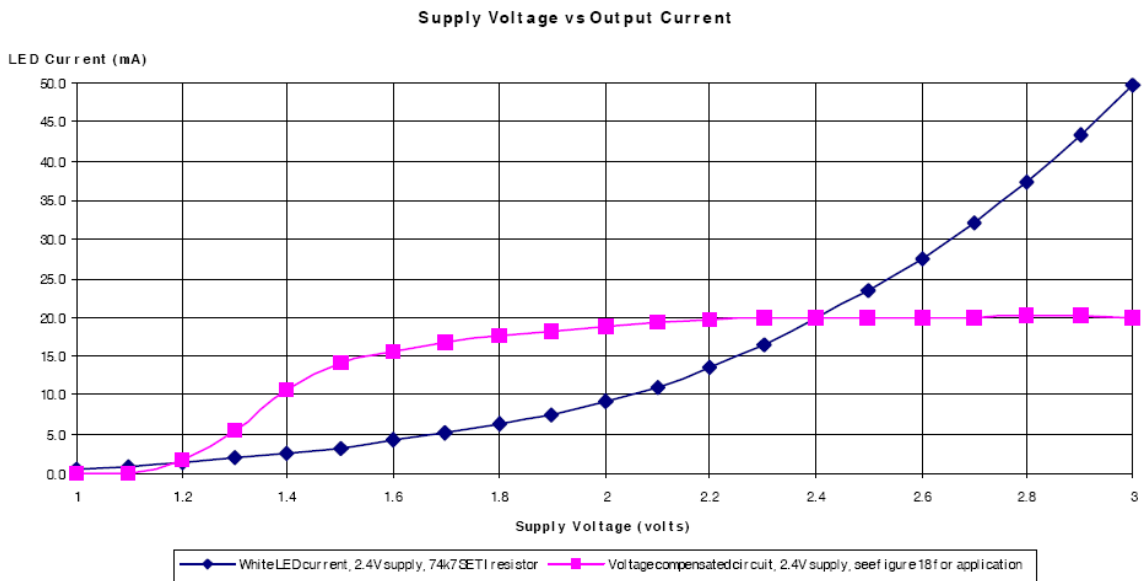

Fig.16 LED current against supply voltage, showing stabilized and uncompensated curves (fig 15 & 4).

9.8 LED drive temperature sensitivity

The variation of LED current with temperature is shown in figure 17.

The increase in LED current with increasing temperature provides compensation for any reduction in light output, and the ability to see the LED light in hotter environments, as

well as tracking the lower output provided by cold batteries.

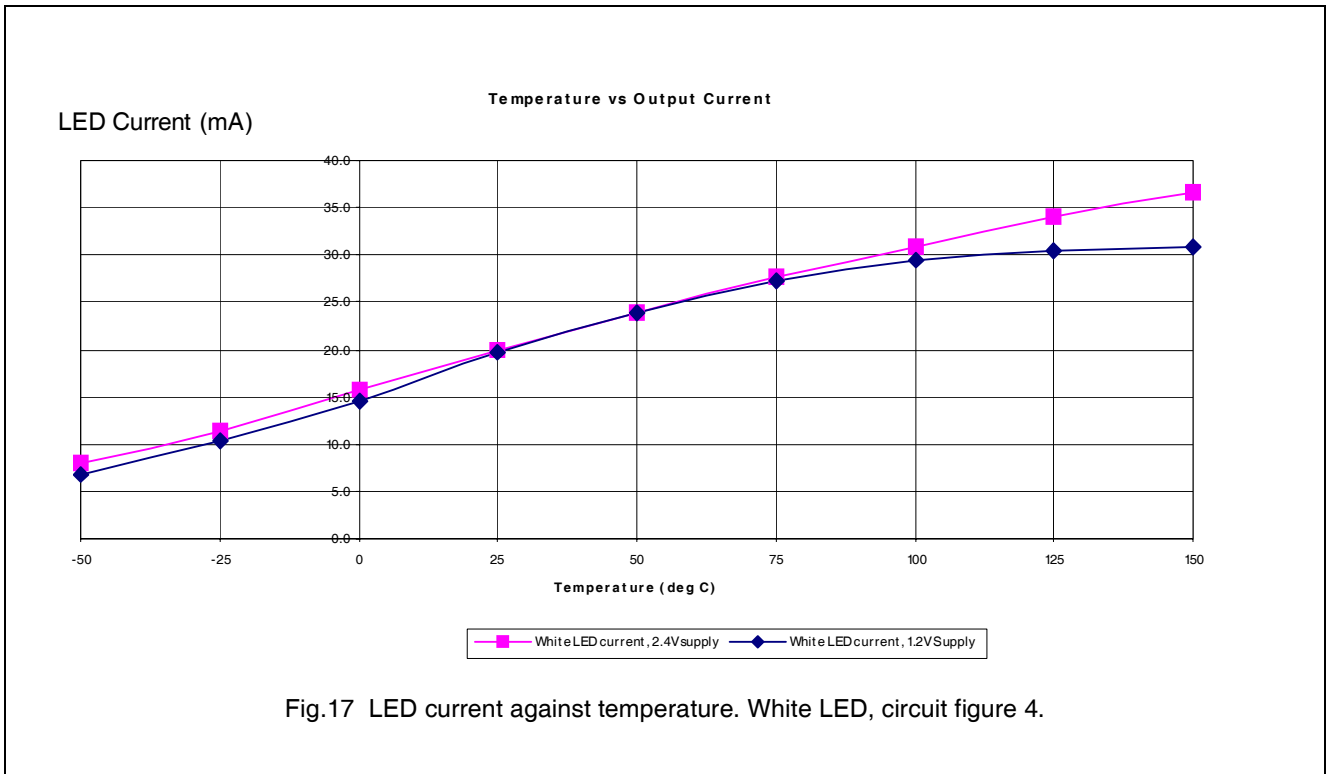

9.9 Voltage boost power supply

The OM5448 is suitable for providing a boosted higher voltage power supply from single or double cell battery circuits. The most simple boost power supply circuit is that shown in figure 18.

The circuit is the same as the DC LED drive circuit of figure 4, except that the LED has been replaced by a zener diode. The disadvantage of this circuit is that if the load current varies over a wide range, the current carried in the zener is wasted energy at times of low load. A regulated supply would be

much better if the load on the battery was only a little more than that needed by the load. Such a regulating circuit is shown in figure 19.

These circuits are limited to an output voltage of a little more than 12 volts, otherwise the maximum voltage permitted on pin OP will be exceeded.

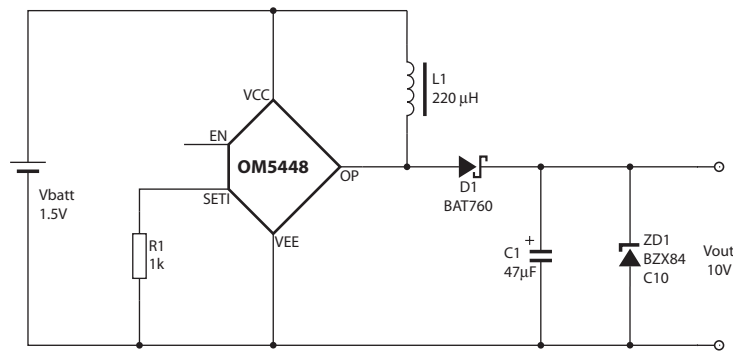

Fig.18 Voltage boost power supply circuit using the OM5448.

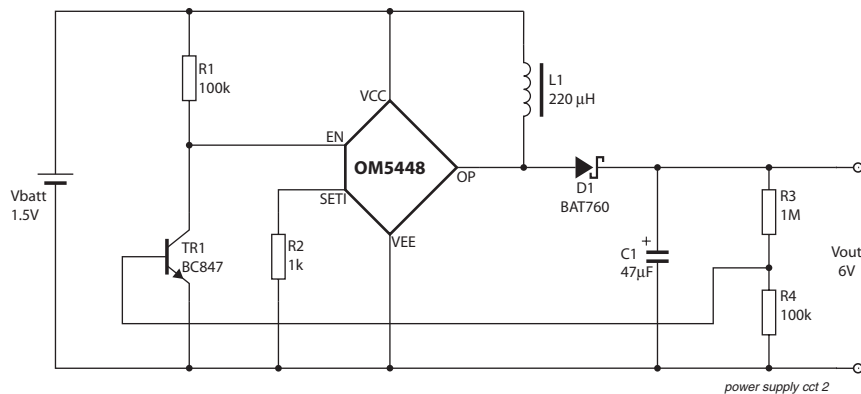

Fig.19 Regulated boost power supply circuit using the OM5448.

9.10 Regulated boost power supply

In the circuit of the regulated boost power supply in figure 19 the OM5448 provides drive to the output regulating circuit until the zener diode begins to conduct. When the zener diode conducts, and sufficient current flows

through R3 to provide sufficient voltage to start to turn on transistor TR1, the collector of TR1 will start to pull the enable pin EN low, turning off the OM5448.

In this way the OM5448 only runs when needed to provide output current, and its input current demands

will track the load. This is a much more efficient circuit than the circuit of figure 18 which is not load regulated.

As in figure 18, the output voltage is limited to 14 volts peak on pin OP (about 12 volts regulated output voltage).

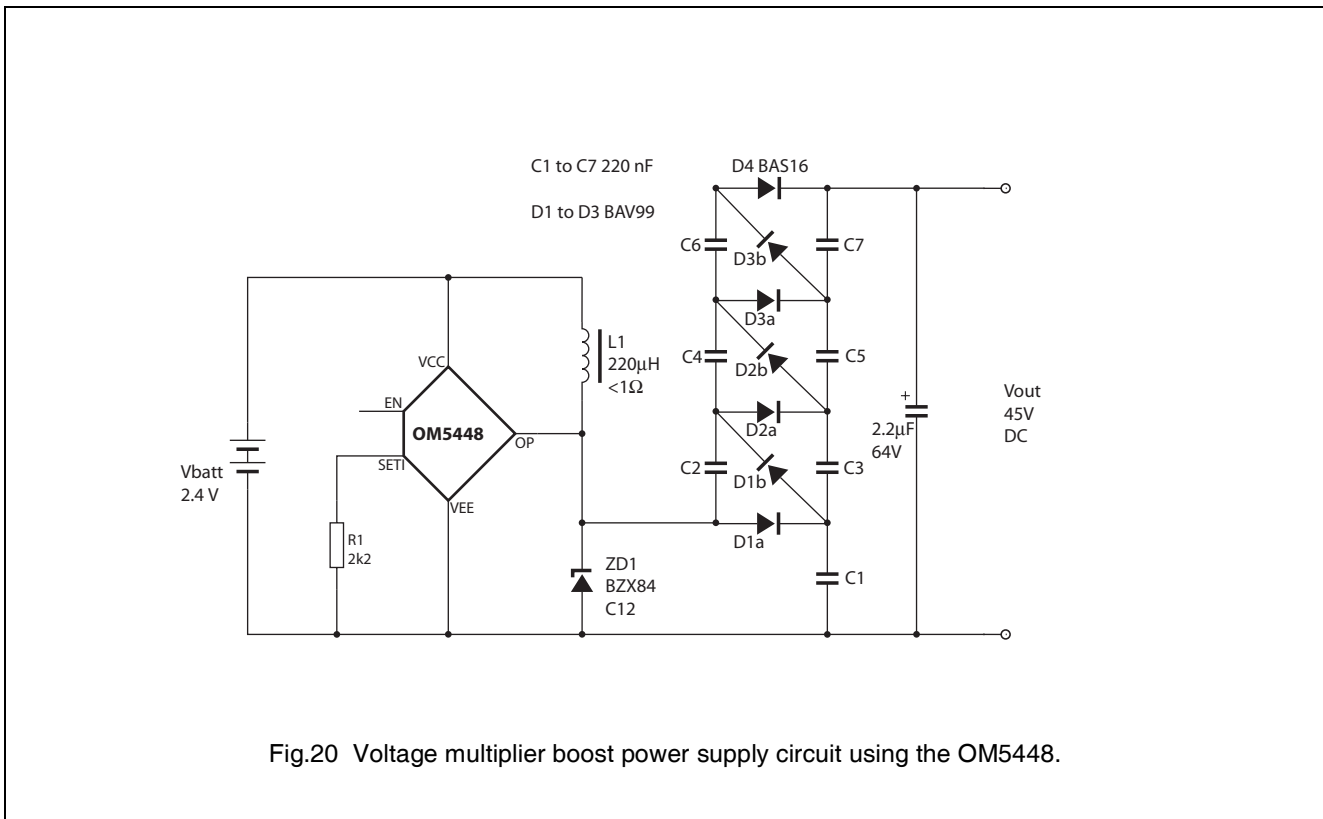

Fig.20 Voltage multiplier boost power supply circuit using the OM5448.

9.11 Voltage multiplier power supply

The voltage output of the OM5448 can be multiplied to offer larger voltages greater than the maximum voltage allowed on pin OP. An example of such an application circuit is shown in figure 20.

This example circuit is not regulated, and uses the zener ZD1 to clamp the output pin to a safe voltage.

9.12 Regulated voltage multiplier power supply

With a few additional components the circuit in figure 20 can be given a voltage regulated output voltage.

Zener diode ZD1 is still needed to prevent excessive voltage on pin OP, and a second zener provides feedback of the output voltage to the enable pin EN to switch off the OM5448 when the voltage out reaches its required value.

While small signal diodes are shown in the voltage multiplier circuit, performance may be improved if Schottky diodes are used, minimising forward voltage drop.

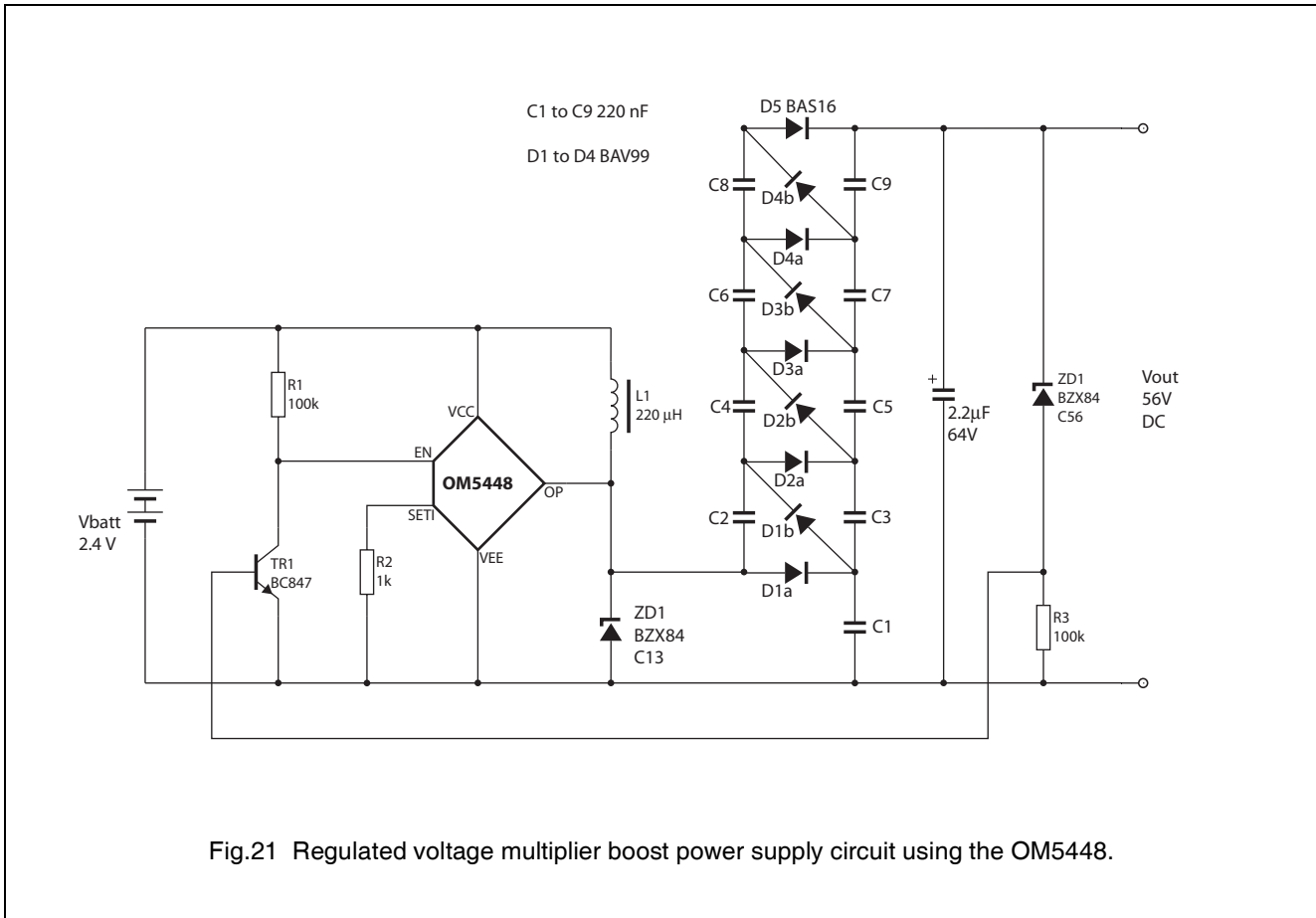

9.13 Negative regulated power supply

The circuit shown in figure 22 shows how the OM5448 can generate a regulated -5 volt supply from a single cell battery. The pulsed signal on OP is level shifted in a capacitor, and rectified to provide the negative output voltage. This output voltage is monitored, and once it has reached the set negative level the enable pin EN is pulled low, disabling the OM5448, and preventing further charging until the voltage has fallen back below the set negative magnitude.

9.14 Use of pin SETI as a control input

As has been seen in the example circuit above, the current flowing into the SETI pin can be varied to give an adjustable output from the OM5448. This can be done mechanically by switching in other resistances, by use of a continuously variable potentiometer, or via electronic feedback to control the output power by electronic means.

9.15 Use of enable (pin EN) as a control input

In addition to being able to vary the output power via the SETI pin, the enable input is also used in the circuit above to disable the OM5448, and to use this control input to limit the power needs of the circuit.

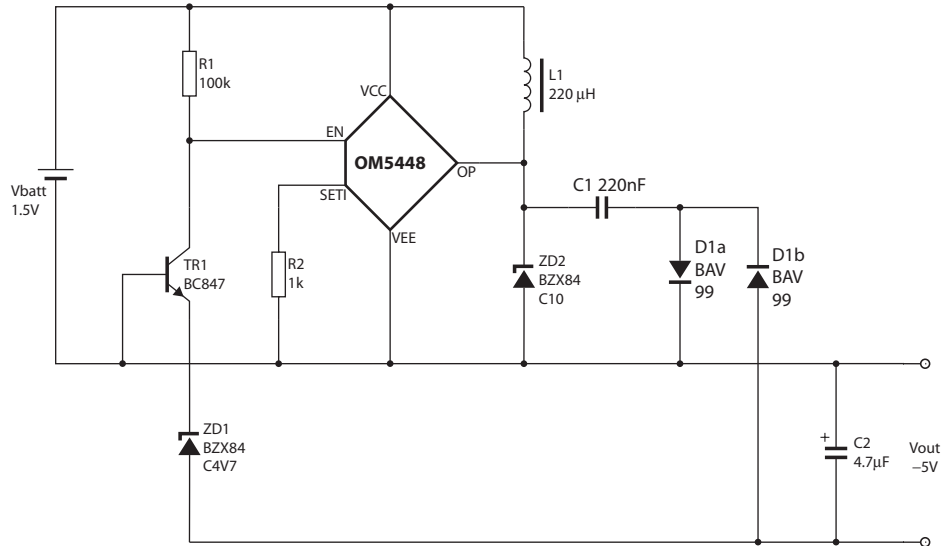



Fig.22 Negative regulated power supply from single cell supply using the OM5448.

10 ORDERING INFORMATION

TYPE NUMBER	PACKAGE			
	NAME	DESCRIPTION	VERSION	ROHS
OM5448	SO23-5	plastic small outline package; 5 leads; body width 1.6 mm	SOP-003	Yes 

Other package options are available. Contact Hendon Semiconductors for details.

For more information on packages, please refer to the document “Integrated Circuit Packaging and Soldering Information”, available from Hendon Semiconductors.

11 ESD CAUTION

Electrostatic Discharge (ESD) sensitive device. ESD can cause permanent damage or degradation in the performance of this device. This device contains ESD protection structures aimed at minimising the impact of ESD. However, it is the users responsibility to ensure that proper ESD precautions are observed during the handling, placement and operation of this device.



12 DOCUMENT HISTORY

REVISION	DATE	DESCRIPTION
0.1	20041015	Initial Draft
0.2	20041109	Typographical corrections
0.3	20060904	HS formatting and ESD Caution
1.0	20070528	Update email address

13 DEFINITIONS

Data sheet status	
Engineering sample information	This contains draft information describing an engineering sample provided to demonstrate possible function and feasibility. Engineering samples have no guarantee that they will perform as described in all details.
Objective specification	This data sheet contains target or goal specifications for product development. Engineering samples have no guarantee that they will function as described in all details.
Preliminary specification	This data sheet contains preliminary data; supplementary data may be published later. Products to this data may not yet have been fully tested, and their performance fully documented.
Product specification	This data sheet contains final product specifications.
Limiting values	
Limiting values given are in accordance with the Absolute Maximum Rating System (IEC 134). Stress above one or more of the limiting values may cause permanent damage to the device. These are stress ratings only and operation of the device at these or at any other conditions above those given in the Characteristics sections of the specification is not implied. Exposure to limiting values for extended periods may affect device reliability.	
Application information	
Where application information is given, it is advisory and does not form part of the specification.	

14 COMPANY INFORMATION

HENDON SEMICONDUCTORS a trading name of INTEGRATED ELECTRONIC SOLUTIONS PTY. LTD.
 ABN 17 080 879 616

Postal address:

Hendon Semiconductors
 PO Box 2226
 Port Adelaide SA 5015
 AUSTRALIA

Street Address:

Hendon Semiconductors
 1 Butler Drive
 Hendon SA 5014
 AUSTRALIA

Telephone: +61 8 8348 5200

Facsimile: +61 8 8243 1048

World Wide Web: www.hendonsemiconductors.com
www.bus-buffer.com

Email: hendon.info@ies-sa.com.au

15 DISCLAIMER

Integrated Electronic Solutions Pty. Ltd. ABN 17 080 879 616 trading as Hendon Semiconductors (“Hendon”) reserves the right to make changes to both its products and product data without notice.

Hendon makes no warranty, representation or guarantee regarding the suitability of its products for any particular purpose, nor does Hendon assume any liability arising out of the use or application of any Hendon product. Hendon specifically disclaims any and all liability, including without limitation incidental or consequential damages.

Typical performance figures, where quoted may depend on the application and therefore must be validated by the customer in each particular application. It is the responsibility of customers to ensure that any designs using Hendon products comply with good practice, applicable standards and approvals. Hendon accepts no responsibility for incorrect or non-compliant use of its products, failure to meet appropriate standards and approvals in the application of Hendon products, or for the correct engineering choice of other connected components, layout and operation of Hendon products.

Any customer purchasing or using Hendon product(s) for an unintended or unauthorised application shall indemnify and hold Hendon and its officers, employees, related companies, affiliates and distributors harmless against all claims, costs, damages, expenses, and reasonable legal fees arising out of, directly or indirectly, any claim of loss, personal injury or death associated with such unintended or unauthorised use, even if such claim alleges that Hendon was negligent regarding the design or manufacture of the relevant product(s).

Life Support Applications

Products of Hendon Semiconductors (Hendon) are not designed for use in life support appliances, devices or systems, where malfunction can result in personal injury. Customers using or selling Hendon products for use in such applications do so at their own risk and agree to fully indemnify Hendon for any damages resulting from such improper use or sale.

