

1 FEATURES

- 0° to 180° AC Phase Control
- Soft Start
- 120V or 230V AC
- Adjustable Gate Pulse Width
- Automatic Retriggering
- Supplied from the mains
- Provides power supply for external sensors/ICs
- Low supply current, low dissipation
- Minimum external components

2 GENERAL DESCRIPTION

The IES5528 Phase Control and General Purpose Triac Triggering IC is a bipolar integrated circuit that outputs negative gate pulses for triggering a triac.

Depending on the control circuit, it functions as a 0° to 180° phase controller, or zero crossing switch. The external configurability of the IES5528 makes it suitable for a wide variety of mains power control applications.

The IES5528 is mains powered, not requiring an expensive DC supply. It also provides an external DC supply rail for powering sensors and/or low power ICs.

The IES5528 allows the engineer design flexibility when implementing a triac driven phase control or switching application. It provides a complete triac control solution.

3 APPLICATIONS

The flexibility of the IES5528 makes it suitable for a variety of applications, such as:

- Light Dimming
- Vacuum Cleaners
- Food Processors
- Temperature Control
- Time-proportional Control
- Home Heating and Cooling
- Ventilation Systems
- Zero Crossing Switching
- Motor Speed Control

4 BLOCK DIAGRAM

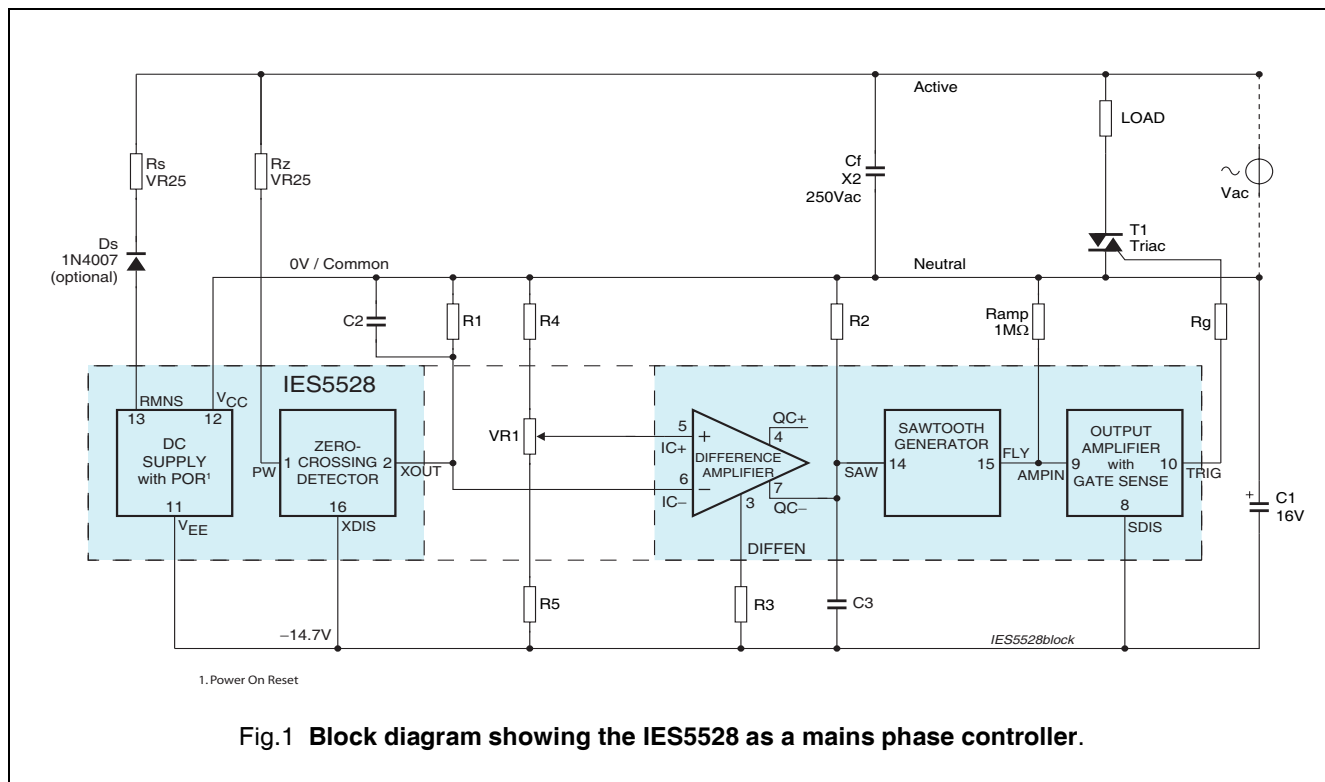

5 PINNING INFORMATION

5.1 Pinning Layout

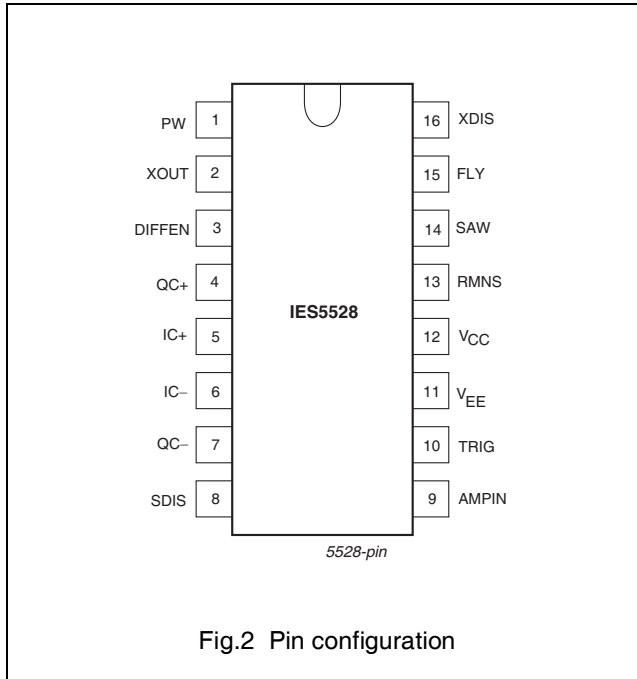

Fig.2 Pin configuration

5.2 Pin Description

SYMBOL	PIN	DESCRIPTION
PW	1	pulse width control input
XOUT	2	zero-crossing detector output
DIFFEN	3	difference amplifier enable output
QC+	4	comparator non-inverting output
IC+	5	comparator non-inverting input
IC-	6	comparator inverting input
QC-	7	comparator inverting output
SDIS	8	triac gate sense disable input
AMPIN	9	output stage input
TRIG	10	output stage output
V _{EE}	11	negative supply
V _{CC}	12	positive supply
RMNS	13	external power resistor
SAW	14	sawtooth generator trigger input
FLY	15	sawtooth generator output
XDIS	16	zero crossing detector disable input

6 FUNCTIONAL DESCRIPTION

The IES5528 can be broken down into the following functional blocks:

- power supply derived from mains AC via dropping resistor R_s
- power on reset to ensure correct start-up
- zero-crossing detector synchronizes triac gate pulses
- difference amplifier passing a signal from a sensor, indication of a potentiometer setting or switch position.
- ramp function generator operating as the saw-tooth oscillator in time proportional or phase control;
- output amplifier driving the triac gate.
- gate sense for reduction in the number of pulses produced when firing the triac;

6.1 Supply

The IES5528 has been designed such that mains is supplied directly to pin RMNS via a dropping resistor (R_s). V_{CC} is connected to the neutral/common line. The circuit produces a negative supply voltage at V_{EE} and has an inbuilt shunt regulator to limit the DC voltage generated between V_{CC} and V_{EE}. This supply may be used for low power external circuit such as a temperature sensing bridge.

The value of R_s should be chosen such that it can supply the current for the IES5528, plus the charge required to drive the triac gate and any external (peripheral) circuits. Any excess current is bypassed through the internal regulator. The maximum rated current must not be exceeded.

The supply current available to the IES5528 when supplied via a dropping resistor (R_s) from mains can be calculated as follows:

$$I_s = \left(\frac{\left(\frac{\sqrt{2} \cdot V_{rms}}{\pi} \right) - (15.4 + V_{D_s})}{R_s} \right) A$$

Where V_{D_s} is the forward voltage across optional diode D_s (refer to figure 1).

During the positive half of the mains voltage cycle the external smoothing capacitor C₁ supplies the IES5528.

The IES5528 may also be powered with an external DC supply into V_{EE} via a current limiting resistor. With V_{CC} being the common pin, isolation requirements may need to be considered. Care must be taken not to exceed the maximum allowable current into the supply.

6.2 Power On Reset

The reset circuit ensures that trigger pulses are not produced until V_{EE} has reached its maximum value and C1 is fully charged. The input SAW (pin14) to the saw-tooth generator is also held at a low state until the reset threshold has been reached.

During start-up the reset holds the input pins to the difference amplifier, IC+ (pin 5) at a high state and IC- (pin 6) at a low state. As a result, functions such as soft and hard start while phase firing can be realised.

The reset circuit should not reactivate unless the voltage across the supply capacitor (C1) drops below approximately 7V.

6.3 Zero Crossing Detector

The IES5528 contains a zero-crossing detector to produce pulses that coincide with the zero crossings of the mains voltage, minimising RF interference and transients on the mains supply.

In a static switch application (see figure 7) where the load to be driven is purely resistive, the synchronization voltage is obtained directly from the mains via a resistor. This ensures trigger pulses start shortly before, and end shortly after each zero-crossing of the mains voltage. Triac conduction is maintained through the mains voltage zero-crossing, minimising triac switching noise.

If the load contains an inductive component, the synchronization will be produced by the internal gate sense circuit rather than the zero-crossing detector. In this case a phase control circuit is used such as that in figure 8. The triac is triggered immediately following zero-crossing of the phase-shifted load current.

6.3.1 PW

The pulse width control input PW (pin 1) allows adjustment of the pulse width at output XOUT (pin 2). This is done by choosing the value of external synchronization resistor R_z between PW and the AC mains.

The pulse width can be determined using the following formula:

$$PW = \left(\frac{1 \times 10^{-5} \cdot R_z}{V_{\text{mains(pk)}} \cdot \pi \cdot f_{\text{mains}}} \right) \text{ s}$$

The above formula is simplified and holds true for small values of PW ($PW < 2\text{ms}$). The error at $PW = 2\text{ms}$ is approximately 1.5%.

6.3.2 XOUT

Output XOUT, which produces negative-going output pulses, is an n-p-n open-collector output that for some applications may require an external pull-up resistor connected to V_{CC} .

6.3.3 XDIS

Input XDIS can be used to disable the zero-crossing detector and inhibit the synchronised pulses provided by XOUT. This is done by injecting a current into XDIS, typically by connecting it via a $1\text{M}\Omega$ resistor to V_{CC} . Input XDIS is connected directly to the base on an n-p-n transistor referenced to V_{EE} , and when not used should be connected directly to V_{EE} . XDIS must never be left floating.

6.4 Difference Amplifier

6.4.1 IC+, IC-, QC+, QC-

IC+ and IC- (pins 5 and 6) are differential inputs of the comparator or differential amplifier, with QC+ and QC- (pins 4 and 7) as complementary outputs. QC+ will be HIGH and QC- will be LOW when IC+ is higher than IC-.

The outputs are open collector n-p-n, and therefore require external pull-up

resistors to realise a “high”. When not used these outputs can be left open circuit.

6.4.2 DIFFEN

The comparator contains a p-n-p current mirror source (referenced to V_{CC}) that is activated by a current out of DIFFEN (pin 3). The current drawn from pin 3 determines the drive for the comparator outputs and has an input to output minimum gain of 50. Typically this current is provided by a resistor connected between DIFFEN and the negative supply rail V_{EE}

6.5 Saw-tooth Generator

The saw-tooth generator may be used to produce bursts of trigger pulses, with the net effect that the load is periodically switched on and off.

With a time-proportional switch, the ramp voltage produced by the saw-tooth generator serves to provide the repetition frequency of load switching that can be adjusted with the control voltage.

In phase control, the flyback of the saw-tooth is used as the drive signal for generating the trigger pulse.

6.5.1 SAW

The firing burst repetition time is usually determined by an external resistor and capacitor connected to the saw-tooth generator trigger input SAW (pin 14). The capacitor (C3) connected to SAW is charged via R2 connected to V_{CC} , and discharged via an internal $10\text{k}\Omega$ resistor.

R2 should not be less than $390\text{k}\Omega$.

Repetition rate and gate pulse width can be set by selecting a suitable value for R2 and C3. See figures 3 and 4 for an easy component selection guide.

When not used, SAW can be left disconnected.

6.5.2 FLY

The output FLY (pin 15) is an n-p-n open-collector output. During the flyback period of the saw-tooth pulse the transistor is ON.

6.6 Output Amplifier

The output stage is used to provide gate pulses of sufficient current to drive a triac.

The output produces negative going gate pulses with respect to V_{CC} / mains neutral. This fires the triac in its most sensitive regions, reducing the amount of gate current needed to latch and hence reducing the overall power consumption.

Depending on the configuration of the drive circuit, the output can be used to provide single gate pulses, or a burst of pulses. The operating mode needs to be taken into account when calculating power supply requirements.

6.6.1 AMPIN

The output amplifier is a non-inverting amplifier. An external pullup resistor connected to AMPIN (pin 9) is used to inhibit the amplifier while pulling AMPIN low will enable the output to sink large currents.

6.6.2 TRIG

The output TRIG (pin 10) is an n-p-n open-collector output capable of sinking large currents.

A gate resistor R_g should be connected between the output TRIG and the triac gate to limit the output current to the minimum required by the triac. By doing this, the total supply current and the power dissipation of the IC are minimised.

Output TRIG is protected with a diode to V_{EE} against damage by undershoot of the output voltage, e.g. caused by an inductive load.

6.7 Gate Sense

The IES5528 is capable of determining the state of the triac. The gate sense circuit ensures that multiple gate pulses are not produced, reducing overall current consumption.

6.7.1 SDIS - GATE SENSE DISABLE

For phase control applications, when gate-sense is enabled (SDIS connected to V_{EE}), and the triac is conducting, the gate sense circuit will prevent any output gate pulses.

For “static switch” applications, where zero-crossing triggering of the triac is required, the gate-sense is disabled by injecting current into SDIS via a resistor connected to V_{CC} .

When the disable function is not being used, SDIS should be connected to V_{EE} . The SDIS pin should never be left disconnected.

7 LIMITING VALUES

In accordance with the Absolute Maximum Rating System (IEC 134).

All voltages specified with respect to V_{CC} / Common.

SYMBOL	PARAMETER	CONDITIONS	MIN.	MAX.	UNIT
$-V_{EE}$	supply voltage supply current		– –	18 15	V mA
V_I	input voltage, all inputs excluding pins RMNS and PW	$I < 1\text{mA}$	$V_{EE} - 0.5$	0.5	V
V_I	input voltage, pin PW	$I < 1\text{mA}$	– 2	2	V
V_I	input voltage, pin RMNS	$I < 15\text{mA}$	$V_{EE} - 1$	1	V
I_I	input current, all inputs excluding pin RMNS and TRIG		–1	1	mA
$I_{RMNS(AV)}$	rectified average		–	15	mA
$I_{RMNS(RM)}$	repetitive peak		–	50	mA
I_{TRIG}	output current	$t < 300\ \mu\text{s}$	–	300	mA
P_{tot}	total power dissipation		–	300	mW
T_{stg}	storage temperature		–40	+150	°C
T_{amb}	operating ambient temperature		–40	+85	°C

8 CHARACTERISTICS

At $T_{amb} = 25^\circ\text{C}$; Voltages with respect to V_{CC} / Common.

SYMBOL	PARAMETER	CONDITIONS	MIN	TYP	MAX	UNIT
Power Supply						
$-V_{EE}$	supply voltage (operating)	$I_{CC} = 1\ \text{mA}$	14.3	14.7	15.3	V
$-I_{EE}$	quiescent current	All function pins open cct	–	170	250	μA
Pulse width control input PW (pin 1)						
V_{PW}	input voltage	$I_{PW} = 100\ \mu\text{A}$ $I_{PW} = -100\ \mu\text{A}$	– –	1.3 –1.3	– –	V V
$I_{PW(\text{Peak})}$	input current	peak value	–	–	1	mA
$I_{PW(+\text{thresh})}$	Positive current threshold		–	11	–	μA
$I_{PW(-\text{thresh})}$	Negative current threshold		–	–9	–	μA
t_{PW}	pulse width	$V = 230\text{Vac}, 50\text{Hz},$ $R_z = 500\text{K}\Omega$	–	100	–	μs
Zero-crossing detector disable input XDIS (pin 16)						
V_{XDIS}	input voltage	inhibit	$V_{EE} + 0.6$	–	–	V
I_{XDIS}	input current		–	–	30	μA
Zero-crossing detector output XOUT (pin 2)						
V_{XOUT}	output voltage (pull-down)	$I_{XOUT} = 100\ \mu\text{A}$	$V_{EE} + 0.6$	$V_{EE} + 0.75$	$V_{EE} + 0.90$	V
I_{XOUT}	max pull down current	$t < 300\ \mu\text{s}$	–	–	10	mA

SYMBOL	PARAMETER	CONDITIONS	MIN	TYP	MAX	UNIT
Comparator input IC+ and IC– (pins 5 and 6)						
V _{IC}	Input voltage range	note1	V _{EE} +1	–	–1	V
I _{IC+}	input bias current	V _{IC+} > V _{IC–} + 1V	–	–	–10	μA
I _{IC–}	input bias current	V _{IC–} > V _{IC+} + 1V	–	–	–10	μA
Comparator outputs QC+ and QC– (pins 4 and 7)						
V _{QC}	output voltage	I _{DIFFEN} = 15 μA	–	V _{EE} + 0.1	–	V
I _{QC}	output current (pull-down)	I _{DIFFEN} = 15 μA	–	500	–	μA
Comparator enable DIFFEN (pin 3)						
I _{DIFFEN}	enable current (pull-down)	R _{DIFFEN} = 1MΩ	–	14	–	μA
Sawtooth generator trigger input SAW (pin 14)						
V _{SAW(H)}	input trigger voltage HIGH		V _{EE} + 4.4	V _{EE} + 5.1	V _{EE} + 5.8	V
V _{SAW(L)}	input trigger voltage LOW		V _{EE} + 1.05	V _{EE} + 1.30	V _{EE} + 1.55	V
I _{SAW(L)}	max pull-down at V _{SAW(L)}		–	50	60	μA
Sawtooth generator output FLY (pin 15)						
I _{FLY}	output current (pull-down)	V _{SAT} = 150mV	–	50	–	μA
Gate sense inhibiting input SDIS (pin 8)						
I _{SDIS}	input current (pull-up)		5.0	–	–	μA
Output stage input AMPIN (pin 9)						
V _{AMPIN}	output drive disable (internal pull-up)	AMPIN pin open cct	–	V _{EE} + 1.2	–	V
I _{AMPIN}	output drive enable (pull-down)	V _{AMPIN} = V _{EE}	3	–	–	μA
Output stage output TRIG (pin 10)						
V _{TRIG}	output voltage	(@ 80mA)	V _{EE} + 80	V _{EE} + 400	V _{EE} + 750	mV
I _{TRIG}	output current (pull-down)	V _{sat} < 0.5V	–	–	80	mA
Reset conditions						
V _{RESET(DIS)}	supply voltage at which the reset is disabled	Supply shunt level must be reached	–	V _{EE}	–	V
V _{RESET(EN)}	supply voltage at which the reset is re-enabled		–	V _{EE} + 7	–	V
V _{RESET(IC+)}	output voltage during reset	IC+ via 1MΩ to V _{EE}	–	–150	–	mV
V _{RESET(IC–)}	output voltage during reset	IC– via 1MΩ to V _{CC}	–	V _{EE} + 800	–	mV
V _{RESET(SAW)}	output voltage during reset	SAW via 1MΩ to V _{CC}	–	V _{EE} + 150	–	mV

Note 1. Either IC– or IC+ may exceed V_{cc} –1V, but not both simultaneously.

8.1 Sawtooth generator pulse width characteristics and component selection

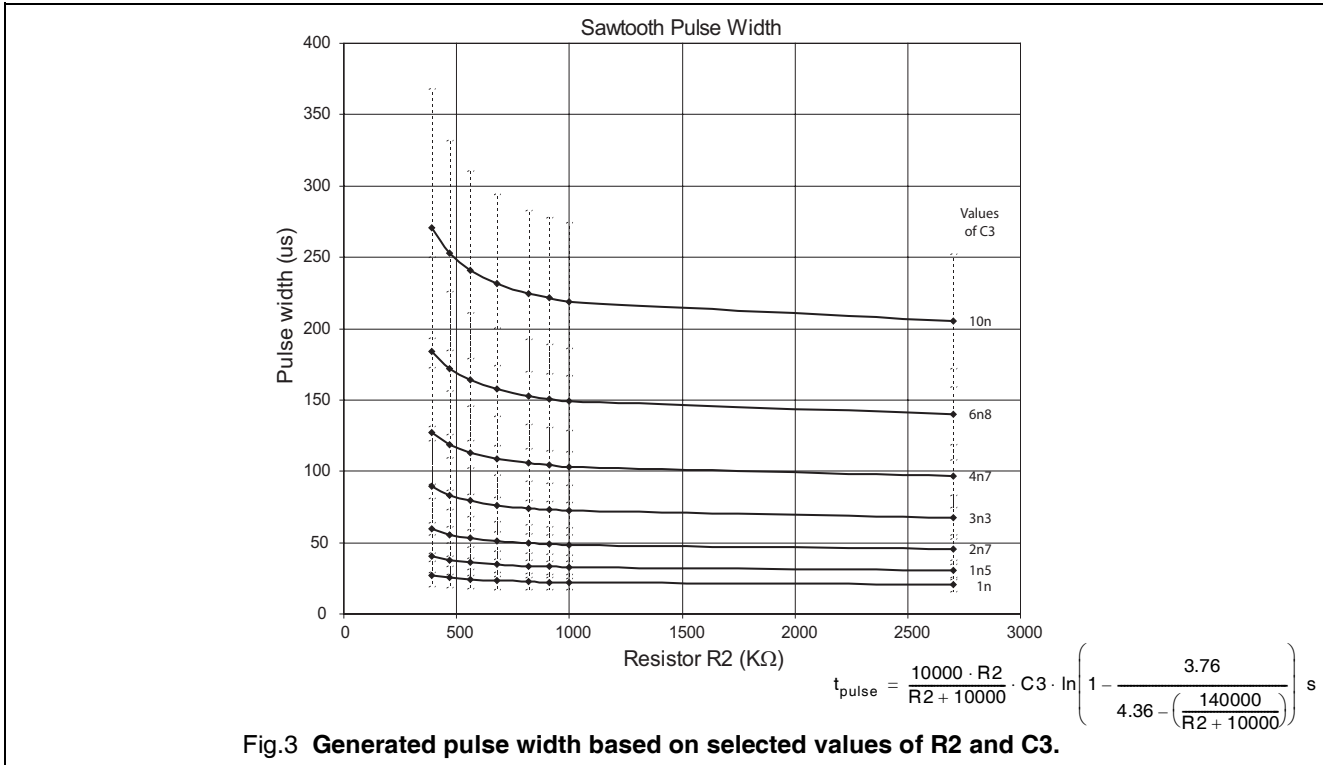

8.2 Sawtooth generator repetition rate characteristics and component selection

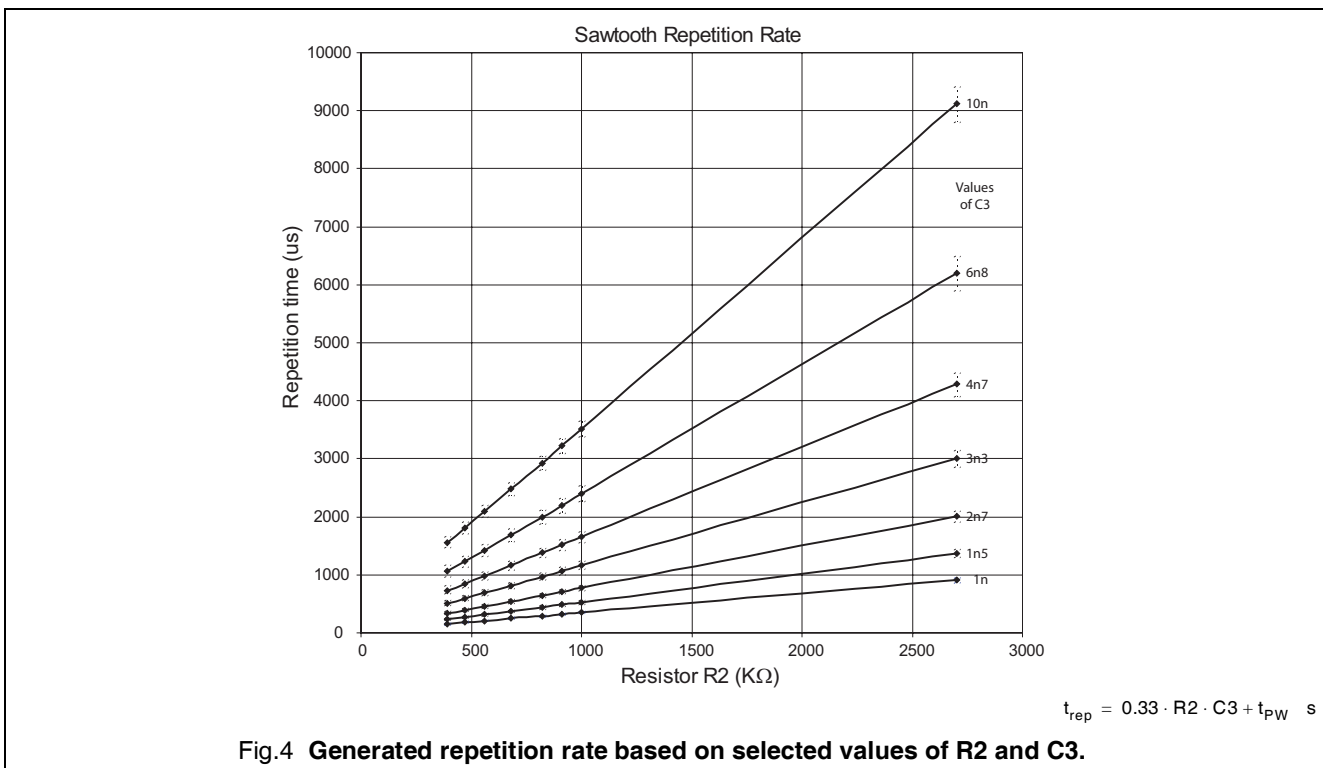

9 APPLICATIONS

9.1 Phase Control Application Circuit

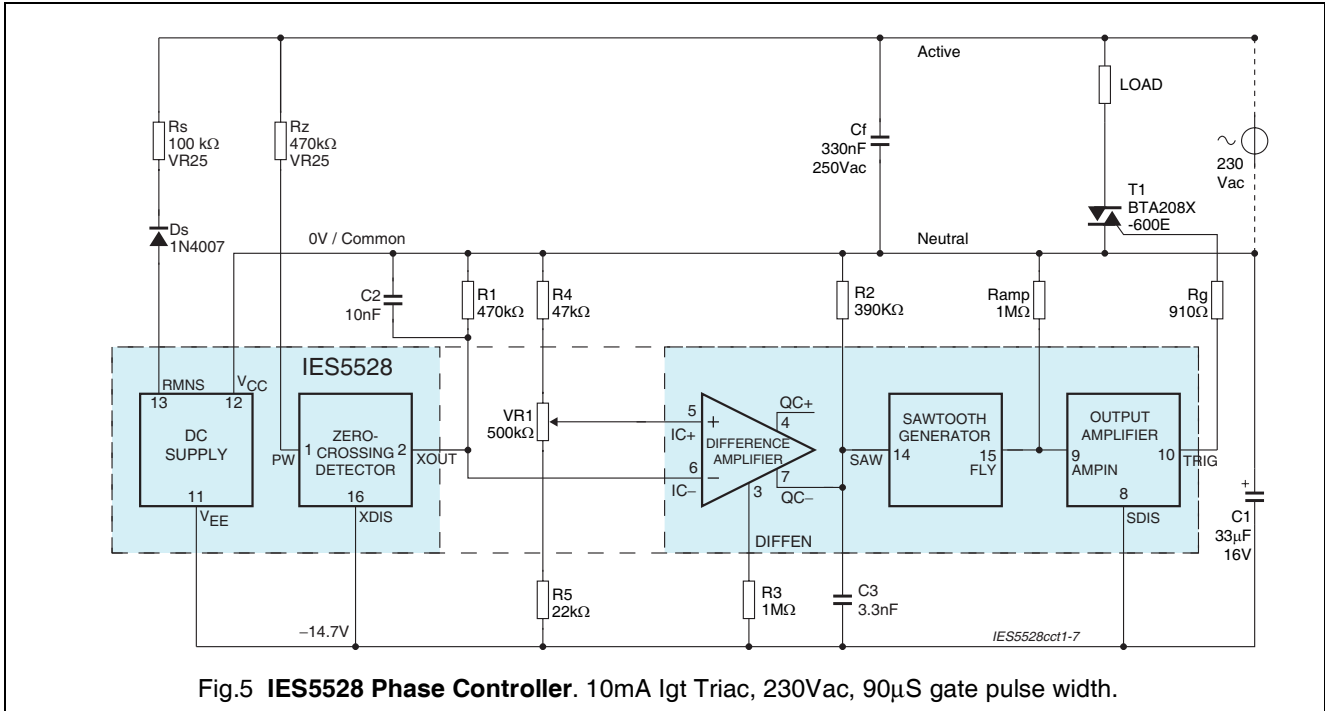

9.2 Phase Control with Soft Start Application Circuit

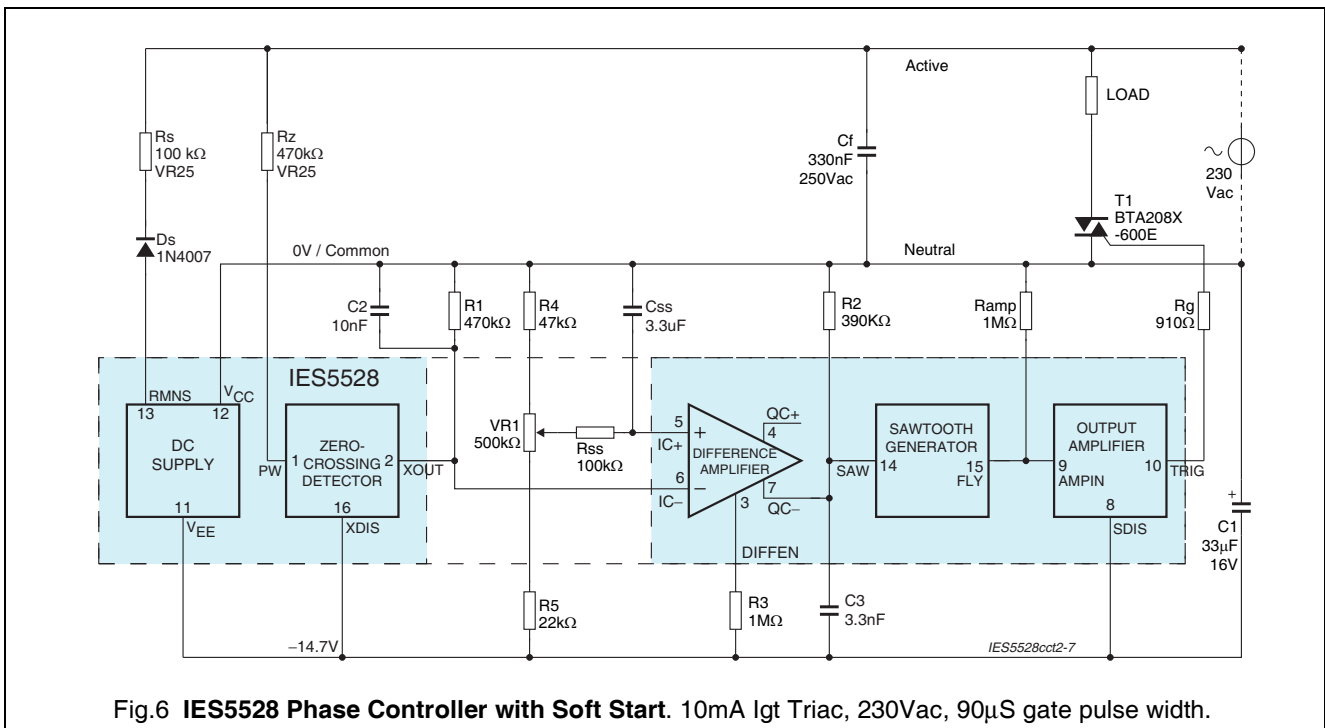

9.3 Component Selection for Phase Control

Use the following table to select components for the phase control application in figures 5 and 6.

The suggested gate resistor (R_g) is based on the triac minimum I_{GT} and includes room for triac gate tolerance. The gate pulse width is calculated assuming $R_2 = 390k\Omega$. Other results may be obtained by using the information given in figures 3 and 4.

TRIAC MINIMUM I_{GT} (I_{TRIG}) (mA)	SUGGESTED R_g (Ω)	GATE PULSE WIDTH (Typical) (μ S)	C3 (nF)	C1 (μ F) (Minimum)	Rs 120V (k Ω) (Maximum)	Rs 230V (k Ω) (Maximum)
5	1800	60	2.2	22	68	120
		90	3.3	22	56	120
		130	4.7	22	56	120
10	910	60	2.2	22	56	120
		90	3.3	33	47	100
		130	4.7	33	39	100
20	470	60	2.2	33	39	100
		90	3.3	33	33	82
		130	4.7	47	27	68
30	300	60	2.2	47	33	82
		90	3.3	47	27	68
		130	4.7	68	22	47
50	180	60	2.2	68	27	56
		90	3.3	68	18	47
		130	4.7	100	15	33

9.4 Component Selection for Soft Start

Use this table to select capacitor C_{ss} . It is the main mechanism for adjusting the soft start of the IES5528. The values listed are a guide, and will need to be tested in application.

Soft Start (s)	C_{ss} (μ F)
0.25	1
0.5	2.2
1	3.3
2	4.7

9.5 Static Switch

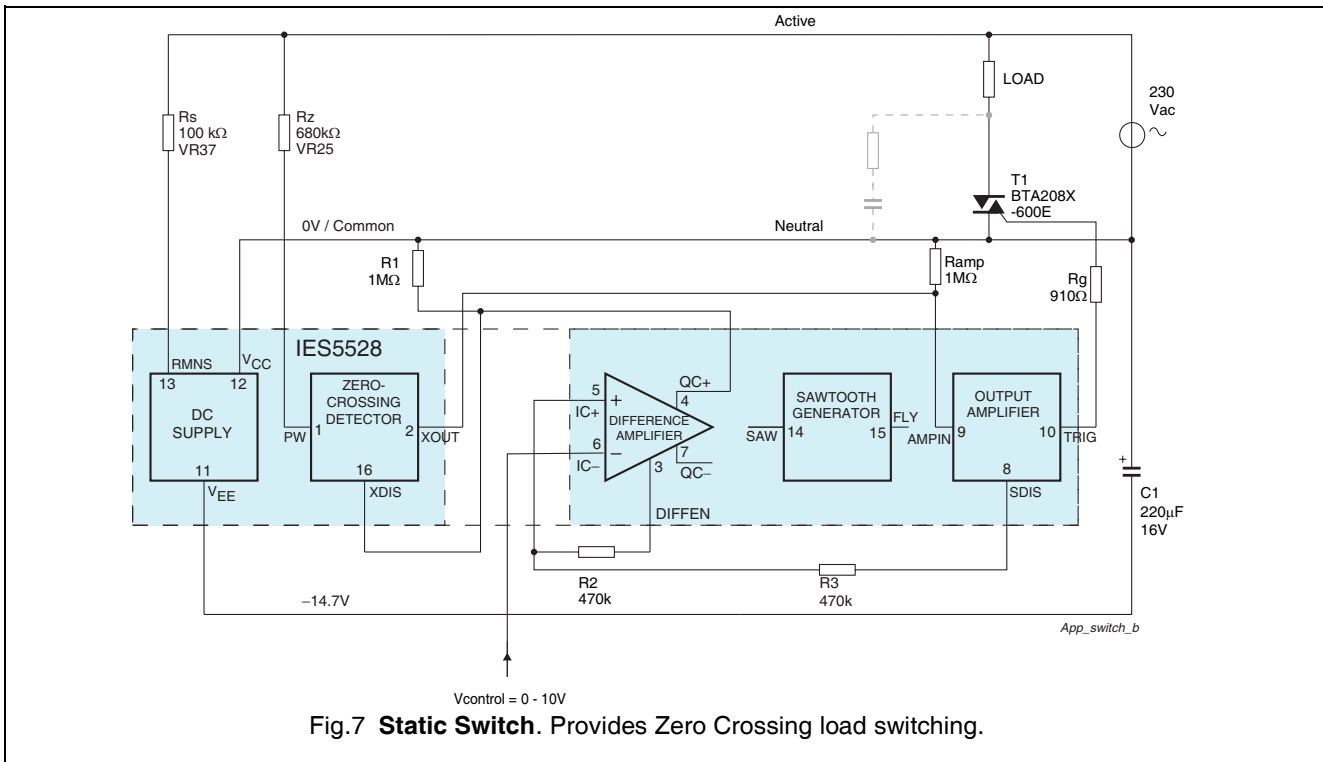

9.6 Soft Start Switch

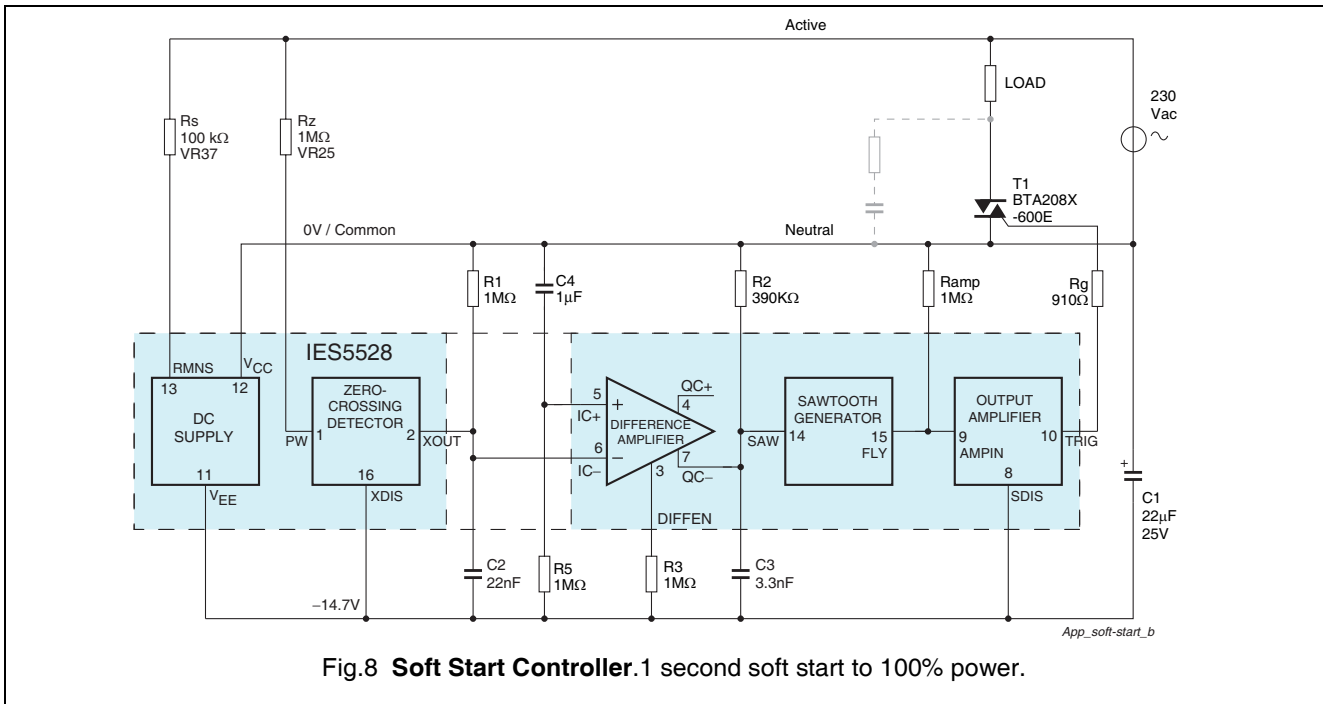

10 IMPORTANT: ELECTRICAL SAFETY WARNING

IES5528 circuit is connected to the mains electrical supply and operates at voltages which need to be protected by proper enclosure and protective covering. Application circuits for IES5528 should be designed to conform to relevant standards (such as IEC 65, or Australian Standards AS3100, AS3250 and AS3300), it should only be used in a manner that ensures the appliance in which it is used complies with all relevant national safety and other Standards.

It is recommended that a printed circuit board using this integrated circuit be mounted with non-conductive clips, and positioned such that the minimum creepage distances from the assembly to accessible metal parts, and between high voltage points cannot be transgressed.

It should be noted that as there are Mains Voltages on the circuit board adequate labelling should be attached to warn service personnel, and others, that this danger exists.

A control board assembly should be mounted, preferably vertically, with sufficient free air flow across its surface to prevent the heat dissipated in various components from causing an unacceptable rise in the ambient temperature. The triac also needs to have an adequate heatsink, as exceeding its rated maximum junction temperature can result in loss of control, unpredictable behaviour, and possible dangerous conditions.

The board should be mounted in a place that is clean and dry at all times, not subject to condensation or the accumulation of dust and other contaminants.

11 ORDERING INFORMATION

TYPE NUMBER	PACKAGE			
	NAME	DESCRIPTION	VERSION	ROHS
IES5528 T	SO16	plastic small outline package; 16 leads; body width 3.9 mm	SOT109-1	Yes 

Notes:

1) The OM5428 was re-branded as the IES5528 to be consistent with the current Hendon Semiconductors type numbering system. Parts and datasheets are otherwise compatible, though due to continuing improvements in the datasheet information, the latest version of the datasheet should always be used.

2) Alternative package types are available- contact Hendon Semiconductors for details. For more information on packages, please refer to the document “Integrated Circuit Packaging and Soldering Information” on the Hendon web site.

12 ESD CAUTION

Electrostatic Discharge (ESD) sensitive device. ESD can cause permanent damage or degradation in the performance of this device. This device contains ESD protection structures aimed at minimising the impact of ESD. However, it is the users responsibility to ensure that proper ESD precautions are observed during the handling, placement and operation of this device.



13 DOCUMENT HISTORY

REVISION	DATE	DESCRIPTION
5.1	20060921	Figure 4 Soft Start, R11 corrected 100k to 300k
5.2	20061106	Figure 4 Soft Start, Values for C7 and C5 corrected
6.0	20080616	Characteristics table updated, Figure component references rationalised. Calculation for gate pulse timing added to Saw-tooth generator description.
7.0	20090520	OM5428 rebranded to IES5528 to fit with IES552x triac control series of IC's.
8.0	20090903	Functional description reworded. Characteristics information added and updated, formulas added and updated. R2 and C3 quick selection graphs added.
8.1	20091102	Issue as Product Specification for release

14 DEFINITIONS

Data sheet status	
Engineering sample information	This contains draft information describing an engineering sample provided to demonstrate possible function and feasibility. Engineering samples have no guarantee that they will perform as described in all details.
Objective specification	This data sheet contains target or goal specifications for product development. Engineering samples have no guarantee that they will function as described in all details.
Preliminary specification	This data sheet contains preliminary data; supplementary data may be published later. Products to this data may not yet have been fully tested, and their performance fully documented.
Product specification	This data sheet contains final product specifications.
Limiting values	
Limiting values given are in accordance with the Absolute Maximum Rating System (IEC 134). Stress above one or more of the limiting values may cause permanent damage to the device. These are stress ratings only and operation of the device at these or at any other conditions above those given in the Characteristics sections of the specification is not implied. Exposure to limiting values for extended periods may affect device reliability.	
Application information	
Where application information is given, it is advisory and does not form part of the specification.	

15 COMPANY INFORMATION

HENDON SEMICONDUCTORS PTY. LTD.

ABN 17 080 879 616

Postal address:

Hendon Semiconductors
PO Box 2226
Port Adelaide SA 5015
AUSTRALIA

Street Address:

Hendon Semiconductors
1 Butler Drive
Hendon SA 5014
AUSTRALIA

Telephone: +61 8 8348 5200

Facsimile: +61 8 8243 1048

World Wide Web: www.hendonsemiconductors.com
www.bus-buffer.com

Email: hendon.info@hendonsemiconductors.com

16 DISCLAIMER

Hendon Semiconductors Pty. Ltd. ABN 17 080 879 616 ("Hendon") reserves the right to make changes to both its products and product data without notice.

Hendon makes no warranty, representation or guarantee regarding the suitability of its products for any particular purpose, nor does Hendon assume any liability arising out of the use or application of any Hendon product. Hendon specifically disclaims any and all liability, including without limitation incidental or consequential damages. It is the responsibility of the customer to ensure that in all respects the application in which Hendon goods are used is suited to the purpose of the end user.

Typical performance figures, where quoted may depend on the application and therefore must be validated by the customer in each particular application. It is the responsibility of customers to ensure that any designs using Hendon products comply with good practice, applicable standards and approvals. Hendon accepts no responsibility for incorrect or non-compliant use of its products, failure to meet appropriate standards and approvals in the application of Hendon products, or for the correct engineering choice of other connected components, layout and operation of Hendon products.

Any customer purchasing or using Hendon product(s) for an unintended or unauthorised application shall indemnify and hold Hendon and its officers, employees, related companies, affiliates and distributors harmless against all claims, costs, damages, expenses, and reasonable legal fees arising out of, directly or indirectly, any claim of loss, personal injury or death associated with such unintended or unauthorised use, even if such claim alleges that Hendon was negligent regarding the design or manufacture of the relevant product(s).

Life Support Applications

Products of Hendon Semiconductors (Hendon) are not designed for use in life support appliances, devices or systems, where malfunction can result in personal injury. Customers using or selling Hendon products for use in such applications do so at their own risk and agree to fully indemnify Hendon for any damages resulting from such improper use or sale.