

MODEL 5C7-347(A)

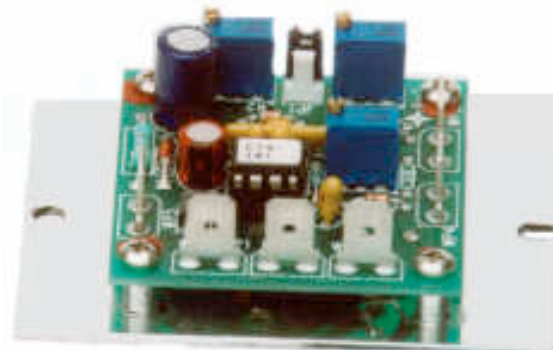

PROPORTIONAL/INTEGRAL  
THERMOELECTRIC  
TEMPERATURE  
CONTROLLER

1. **Application:**

The 5C7-347 is a temperature controller designed to operate a thermoelectric module. The 5C7-347 is field configured to operate a thermoelectric module in either a cooling or a heating mode. When configured to operate in the heating mode, the controller can drive a resistive heating element.

2. **System Overview:**

The unit consists of a Micro Controller, Set Temperature Potentiometer, Proportional Bandwidth Potentiometer, Integral Gain Potentiometer, Temperature Sensor Input, and a Power Output Stage.

The Micro Controller acquires the actual temperature from the Temperature Input Sensor. The Micro Controller sends a signal to the Power Output Stage based on Proportional/Integral Gain of the desired temperature versus the acquired input temperature. The Power Output Stage will drive a thermoelectric (Peltier effect) module to attain the desired temperature. via A Pulse width Modulated Output.

3. **Specifications:**

The specifications of the controller are listed on the Customer Drawing in the back of this manual.

4. **5C7-347 Wiring:**

The wiring diagram of the controller is listed on the Customer Drawing in the back of this manual.

5. **Control Function Description:**

5.1. Proportional Control:

5.1.1. Proportional control eliminates the temperature cycling inherent in Deadband control. Bandwidth is the temperature span over which the power is proportioned from 0% to 100% power.

5.1.2. The Proportional Control reduces the percentage of power applied to the load, as the temperature reaches the set temperature point.

5.1.3. Example:

5.1.3.1. Set temperature of 100°C with a proportioning bandwidth of 10°C

5.1.3.2. The control function starts to proportion the load power when the control sensor is at 95°C. The proportional power is at 50% power when the control sensor is at 100°C.

The proportional power is at 0 when the control sensor temperature is at 105°C.

5.2. Proportional/Integral Control:

5.2.1. Adjusts the proportional power based on the difference of the control sensor temperature from the desired set temperature. The Integral action compensates for changes in loading and temperature offset (Droop) within the controller's proportional bandwidth.

5.2.2. Example:

5.2.2.1. Set temperature of 100°C with a proportioning bandwidth of 20°C and an Integral Gain of 1 Repeat per Minute.

5.2.2.2. If the unit is set for a Integral Gain of 1 Repeat/Minute with a constant 5°C temperature error lower than the set point at 75% power. The integral action will move the proportioning power to 100% in 1minute.

6. **Tuning the PI Controller**

6.1 Tuning of PI Control requires knowing the time period of the natural temperature cycle of the system, and the bandwidth used to achieve this cycle.

6.2. The tuning process requires the integral variable to be set to zero by adjusting the Integral Gain Potentiometer to maximum Counter Clockwise.

6.3. Set the proportional bandwidth potentiometer to maximum Counter Clockwise.

6.4. Adjust the Set Temperature Potentiometer until the temperature is within the range +/- 10°C of the desired temperature.

- 6.5. Slowly adjust the Proportional Bandwidth Potentiometer Clockwise, counting the number of turns used, until a small sustained temperature oscillation is observed.
  - 6.5.1. Record the number of turns on the Proportional Bandwidth Potentiometer to sustain the temperature oscillation.
  - 6.5.2. \_\_\_\_\_ Turns
- 6.6. The time of this temperature oscillation is the natural period.
  - 6.6.1. Record the time of the natural period of the unit in minutes.
  - 6.6.2. \_\_\_\_\_ Minutes
- 6.7. Turn the Proportional Bandwidth Potentiometer Clockwise the number of turns recorded above, thus doubling the bandwidth.
- 6.8. Set the controller Integral Gain variable (repeats per minute) to the reciprocal of the natural period. Each turn of the Integral Gain Potentiometer is 0.1 repeats per minute.
- 6.9. The above values are ballpark settings and may need further minor adjustments. Record the final number of turns used on the Proportional bandwidth Potentiometer and Integral Gain Potentiometer.
  - 6.9.1. Final number of turns of the Proportional Bandwidth Potentiometer = \_\_\_\_\_ from maximum Counter Clockwise.
  - 6.9.2. Final number of turns of the Integral Gain Potentiometer = \_\_\_\_\_ from maximum Counter Clockwise.
- 6.10. Additional systems with the same thermal dynamic properties will operate using the Potentiometer settings

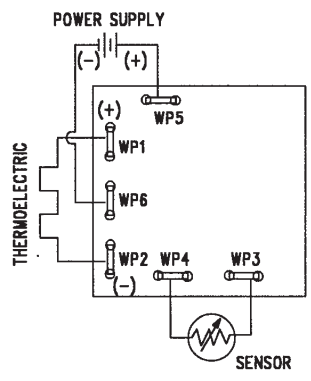
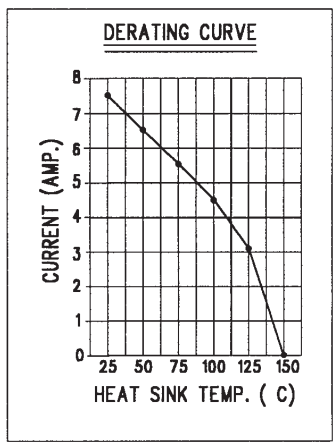
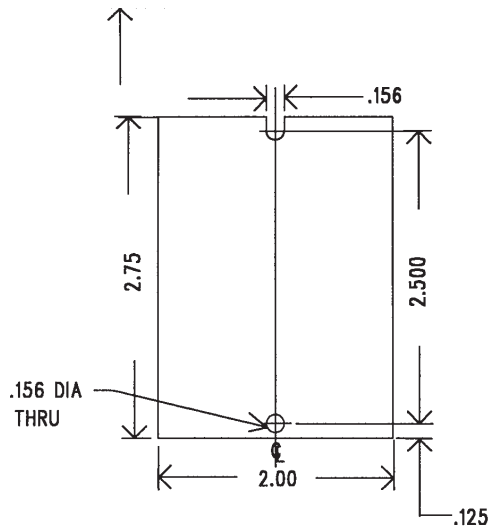
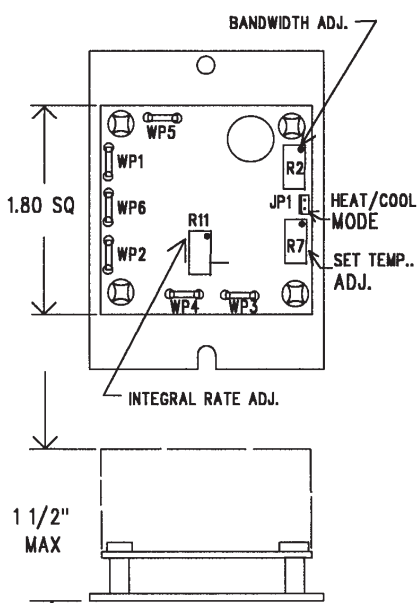

# 5C7-347A REMOTE SET TEMP POT

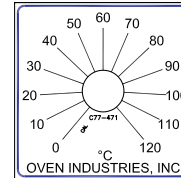
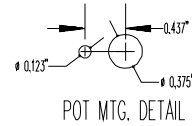
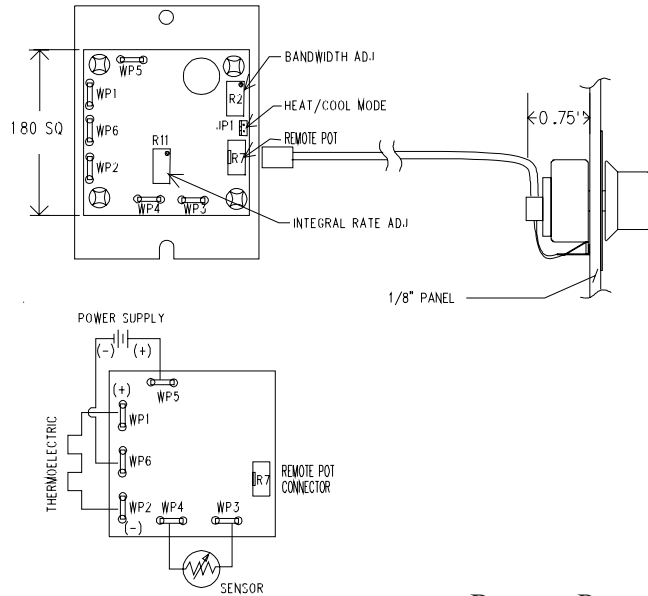

1.70"  
Sq.

Remote Pot with 3' of cable, knob, & dial scale included

## SPECIFICATIONS

INPUT: 9-26 VDC REVERSE POLARITY PROTECTED

OUTPUT: 7.5 AMP WITH A 25°C MOUNTING PLATE

TEMPERATURE (SEE DERATING CURVE).

PULSE WIDTH MODULATED WITH BASE FREQUENCY OF 400HZ

OUTPUT IS LINEAR CURRENT LIMITING TO 14 AMPS

OUTPUT DEVICE HAS BUILT IN THERMAL SHUT DOWN

TEMPERATURE SENSOR: O.I. TS104 (SOLD SEPERATELY)

SET TEMPERATURE ADJUSTMENT: 0°C TO +120°C

(CW INCREASE)

BANDWIDTH ADJUSTMENT: 0.5°C TO 5.0°C (CW INCREASE)

INTEGRAL RATE ADJUSTMENT: 0 TO 2.55 REPEATS PER/MIN

(CW INCREASE)

HEATING OR COOLING MODE: HEATING = JP1 OPEN,

COOLING = JP1 SHORTED (FACTORY DEFAULT)

## WIRING

CONNECTIONS ARE VIA .250 QUICK CONNECT TERMINAL

WP1 = (+) TO THERMOELECTRIC MODULE

WP2 = (-) TO THERMOELECTRIC MODULE

WP3 = TS104 SENSOR

WP4 = TS104 SENSOR

WP5 = +12 TO +24 VDC INPUT

WP6 = (-) VDC RETURN

*Sensor TS104 Series Temp Range 0°C to 120°C*

# Model 5C7-347 Application Note

Joe likes a hot beverage during the winter and a cold beverage in the summer. An Oven Industries, Model 5C7-347A Thermoelectric Controller and a TS104 Sensor with a Thermoelectric Module and some common electronic parts allows Joe to keep his beverage the way he likes it.

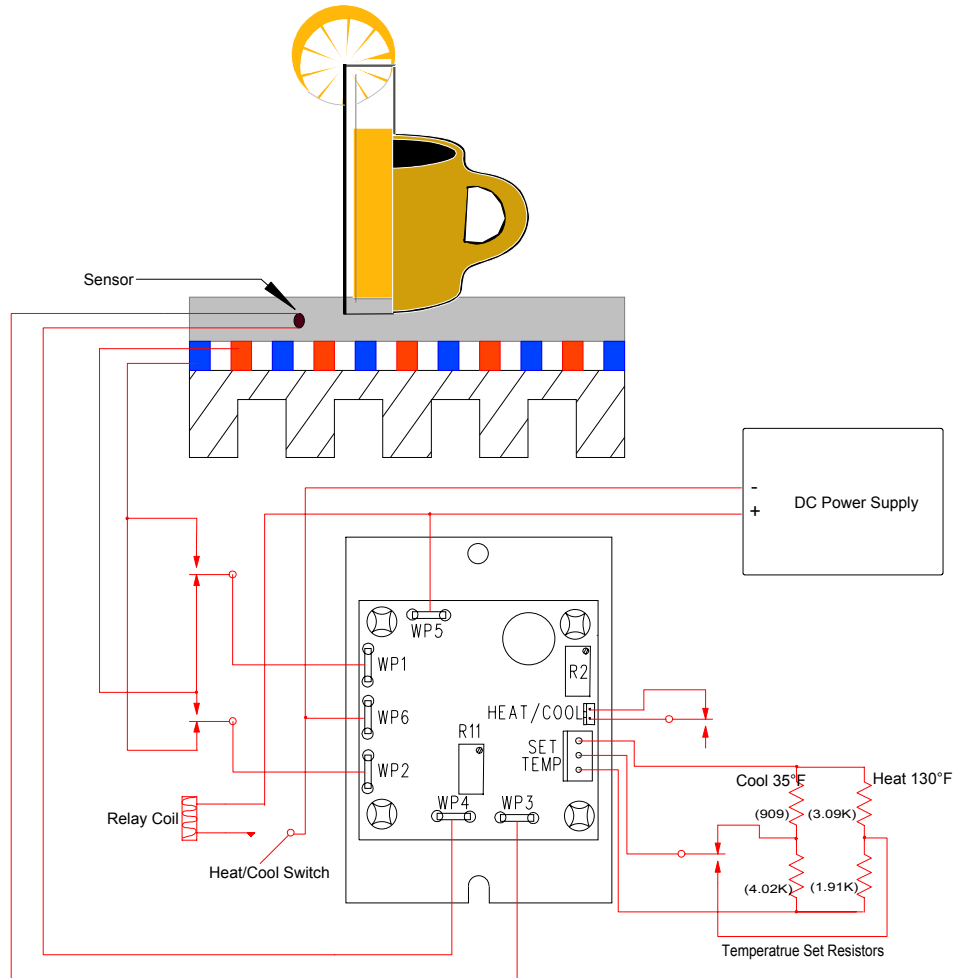

*In no event shall Oven Industries, Inc. be liable for any damages whatsoever (including without limitation, damage for loss of business profits, business interruption, loss of business information, or any other pecuniary loss) arising out of the use or inability to use this Oven Industries, Inc. product, even if Oven Industries, Inc. has been advised of the possibility of such damages.*



207 Hempt RD.  
Mechanicsburg PA 17055  
717-766-0721  
[www.ovenind.com](http://www.ovenind.com)