



Genesys Logic, Inc.

GL862C

USB 2.0 PC Camera Controller

Product Overview



Copyright

Copyright © 2012 Genesys Logic, Inc. All rights reserved. No part of the materials shall be reproduced in any form or by any means without prior written consent of Genesys Logic, Inc.

Ownership and Title

Genesys Logic, Inc. owns and retains of its right, title and interest in and to all materials provided herein. Genesys Logic, Inc. reserves all rights, including, but not limited to, all patent rights, trademarks, copyrights and any other propriety rights. No license is granted hereunder.

Disclaimer

All Materials are provided “as is”. Genesys Logic, Inc. makes no warranties, express, implied or otherwise, regarding their accuracy, merchantability, fitness for any particular purpose, and non-infringement of intellectual property. In no event shall Genesys Logic, Inc. be liable for any damages, including, without limitation, any direct, indirect, consequential, or incidental damages. The materials may contain errors or omissions. Genesys Logic, Inc. may make changes to the materials or to the products described herein at anytime without notice.

Genesys Logic, Inc.

12F., No. 205, Sec. 3, Beixin Rd., Xindian Dist. 231,
New Taipei City, Taiwan
Tel : (886-2) 8913-1888
Fax : (886-2) 6629-6168
<http://www.genesyslogic.com>



GENERAL DESCRIPTION

The GL862C is a high performance USB 2.0 UVC compliant controller for PC Camera and NB camera application. With the Genesys Logic's highly recognized self-developed USB high-speed transceiver, GL862C provides up to 30 fps at VGA or capture still images at 2 Mega pixels for fulfilling the mass bandwidth demand of video transferring. GL862C also supports USB isochronous mode to provide certain bandwidth to insure user can get satisfied usage experience on video application even running high bandwidth consumption devices concurrently.

The GL862C is compliant with USB Video Class 1.1, can work with Microsoft native driver that already bundled at WinXP SP2 and Vista. It makes you use USB PC Camera as you use an USB flash disk. Additionally, the GL862C provides an alternative proprietary driver to meet better image performance and special function requirement.

The GL862C integrates a flexible sensor interface to make it easily to couple with versatile CMOS sensors on market. The GL862C is low power consumption and low operation temperature that efficiently avoid the noise signals of sensor induced by USB camera controller

FEATURES

- USB Function
 - Compliant with USB 2.0 high-speed and full-speed.
 - Compliant with USB Video Class 1.1.
 - Support USB 2.0 Isochronous Video pipe to 24MB/s.
- System
 - Embedded 8052 micro-controller, operate @ 15 MHz clock.
 - Built-in 5V to 3.3V regulator
 - 3.3V/1.8V operation
 - Built-in PLL – support frequency (20~100MHz)
 - Support on-line firmware upgrade
 - The sensor, UVC, property control setting could be stored in external EEPROM or SPI flash
 - Support alternative proprietary driver to enhance image performance
- Sensor Interface
 - Support up to 2M CMOS Soc-Sensor
 - Support UVC uncompressed YUY2 payload
 - Support UVC MJPEG payload
 - Support 54MHz pixel clock
 - Support I2C for sensor control
- Frame Rate
 - Non-UVC mode, worked with proprietary driver
 - Support YUV/RGB/I420 format
 - Video stream up to : 12 fps in UXGA, 15 fps in SXGA, 30 fps in VGA
 - UVC Class mode, worked with OS native driver
 - Support UVC uncompressed YUY2 payload
 - Video stream up to : 5 fps in UXGA, 7 fps in SXGA, 30 fps in VGA
 - Still image captured up to UXGA
- USB Certification
 - Pass the WHQL test of WinXP and Vista
 - Pass the USB-IF UVC test
- Platform Support
 - WinXP32/64, Vista 32/64,
 - MacOS X 10.4.8 and later
 - Linux UVC driver
- Package
 - Available at 48pin LQFP/LQFN and 46pin LQFN packages

BLOCK DIAGRAM

Function Block

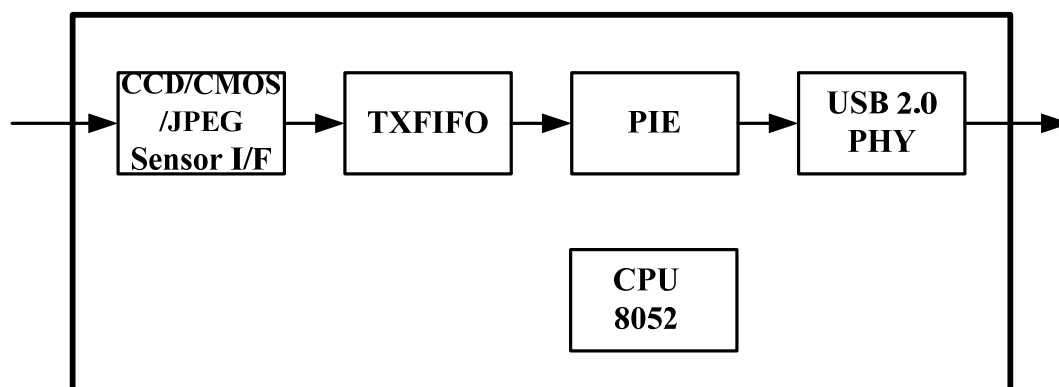

- **CCD Module/CMOS Sensor Interface**

GL862C can link with popular CMOS sensor on market for PC camera application. GL862C can be configured by different sensor requirement. If sensor is acting as master, GL862C can accept HSYNC/VSYN from sensor. If GL862C is configured as a master HSYNC/VSYN will be provided by GL862C to sensor. GL862C keep the most flexibility to fit most of the sensors. The detail of configuration needs to refer to GL862C Application Note. For most sensors no matter of YUV format or RGB format, they can be easily transferred image data to PC by GL862C.

- **TXFIFO**

GL862C build in 6K byte internal buffer for USB high bandwidth application. This 6K internal buffer can be used as transmitted buffer of isochronous pipe. In USB specification, the highest bandwidth of isochronous pipe is 24Mbyte/second, that can be easily derived to maximum frame rate depending on configuration. For example, frame rate can be easily achieved to 30 frames per second if image size is 640 x 480 if raw data output and sensor clock is 15M.

- **PIE**

PIE handles the USB protocol defined in chapter 8 of *USB specification Revision 2.0*. It co-works with CPU to play the role of the chip's kernel. The main functions of PIE include the state machine of USB protocol flow, CRC check, PID error check, and timeout check. Unlike USB1.1, bit stuffing/de-stuffing is implemented in UTMI, not in PIE.

- **USB 2.0 PHY (UTMI)**

UTMI handles the low level USB protocol and signaling. It's designed based on the Intel's UTMI specification 1.01. The major functions of UTMI logic are to handle the data and clock recovery, NRZI encoding/decoding, Bit stuffing /de-stuffing, supporting USB2.0 test modes, and serial/parallel conversion.

- **CPU**

CPU is the micro-processor unit of GL862C. It is an 8-bit 8052 processor with 16KB ROM and 256 bytes RAM. It operates at 15Mhz clock to decode the USB command issued from host and then prepares the data to respond to the host. In addition, μC can handle GPIO (general purpose I/O) settings and reading content of EEPROM to support high flexibility for customers of different configurations of chip. These configurations include self/bus power mode setting, individual/gang mode setting, downstream port number setting, device removable/non-removable setting, and PID/VID setting.



Operation Mode

For customized firmware, flash memory can use as external program memory of CPU. This is for customer to develop their firmware. This is only available for 100-pin package type.

With Flash Memory

- Only available in 100-pin QFP package
- Force EXTCPU = 0
- GPIO10 pull-down
- GPIO13/GPIO14 used as serial bus to configure sensor

Without Flash Memory

- If 100 pin, set EXTCPU = 0
- GPIO10 pull-up
- GPIO13/GPIO14 are used as serial bus to configure sensor