

# iC-MFP

## 8-FOLD FAIL-SAFE P-FET DRIVER

target specification



Rev A2, Page 1/13

### FEATURES

- ◆ 8-fold level shift up to 40 V output voltage
- ◆ Inputs compatible with TTL and CMOS levels, 40 V voltage proof
- ◆ Voltage swing configurable to 5 V, 10 V or supply voltage
- ◆ Short-circuit-proof push-pull current sources for driving FETs slowly
- ◆ Safe high output state with single errors
- ◆ Ground and supply voltage monitor
- ◆ Status output for error and system diagnostics
- ◆ Temperature range from -40 to 125 °C
- ◆ Protective ESD circuitry

### APPLICATIONS

- ◆ Operation of P-FETs from 1.8 V, 2.5 V, 3.3 V or 5 V systems

### PACKAGES

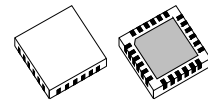

QFN24

### BLOCK DIAGRAM

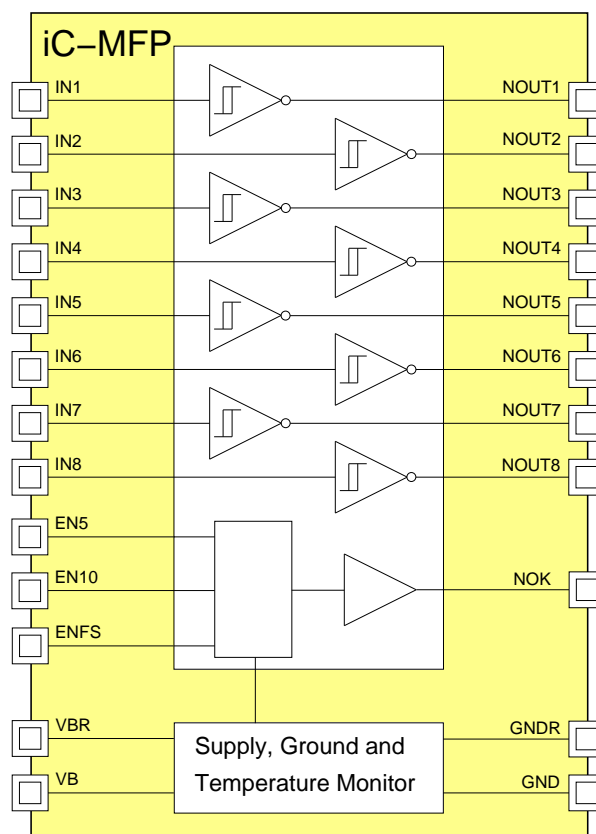

### DESCRIPTION

iC-MFP is a monolithically integrated, 8-channel inverting level adjustment device which drives P-channel FETs. The internal circuit blocks have been designed in such a way that with single errors, such as open pins (VB, VBR, GND, GNDR) or the short-circuiting of two outputs, iC-MFP's output stages switch to a predefined, safe high state. Externally connected P-channel FET are thus shut down safely in the event of a single error.

The inputs of the eight channels consist of a Schmitt trigger with a pull-down current source and are compatible with TTL and CMOS levels and are voltage-proof up to 40 V. The eight channels have a current-limited push-pull output stage and a pull-up resistor at the output. The hi-level at one of the inputs EN5, EN10 or ENFS defines the output lo-level VB - 5 V, VB - 10 V or GND voltage and enables the outputs. The output lo-level is disabled with the lo-level at all inputs EN5, EN10 and ENFS or with the hi-level at more than one input.

iC-MFP monitors the supply voltage at VB and VBR pin and the voltages at the two ground pins GND and GNDR. Both power supply pins VB and VBR and both pins GND and GNDR must be connected together externally in order to guarantee the safe high state of the output stages in the event of error.

Should the supply voltage at VB undershoot a predefined threshold, the voltage monitor causes the outputs to be actively tied to VB via the highside transistors. If the supply voltage ceases to be applied to VB, the outputs are tied to VBR by pull-up resistors.

If the connection between the ground potential and the GND or GNDR pin is disrupted, the highside transistors are activated.

Pull-down currents provide the safe lo-level at open inputs IN1...8, EN5, EN10 and ENFS. The pull-down currents have two stages in order to minimize power dissipation with enhanced noise immunity.

When two outputs of different logic states are short circuited, the driving capability of the highside driver predominates, keeping the connected P-channel FETs in a safe shutdown state.

The status of the device is indicated with the Open-Drain pin NOK and can be used for system diagnostics.

Temperature monitoring protects the device from too high power dissipation.

The device is protected against destruction by ESD.

### PACKAGES QFN24 4 mm x 4 mm to JEDEC

#### PIN CONFIGURATION QFN24 (top view)

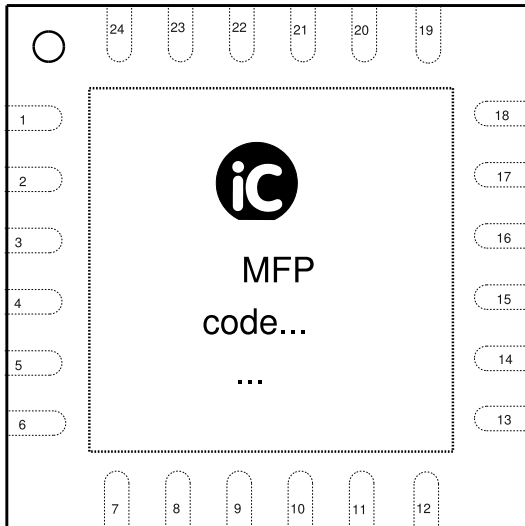

#### PIN FUNCTIONS

| No. | Name  | Function                               |
|-----|-------|--|
| 1   | NOUT1 | Output channel 1                       |
| 2   | VB    | Supply Voltage                         |
| 3   | VBR   | Supply Voltage (R)                     |
| 4   | EN5   | Enable input lo-level = VB-5V          |
| 5   | EN10  | Enable input lo-level = VB-10V         |
| 6   | IN1   | Input channel 1                        |
| 7   | IN2   | Input channel 2                        |
| 8   | IN3   | Input channel 3                        |
| 9   | IN4   | Input channel 4                        |
| 10  | IN5   | Input channel 5                        |
| 11  | IN6   | Input channel 6                        |
| 12  | IN7   | Input channel 7                        |
| 13  | IN8   | Input channel 8                        |
| 14  | NOK   | Output inverted status                 |
| 15  | ENFS  | Enable input full scale lo-level = GND |
| 16  | GNDR  | Ground (R)                             |
| 17  | GND   | Ground                                 |
| 18  | NOUT8 | Output channel 8                       |
| 19  | NOUT7 | Output channel 7                       |
| 20  | NOUT6 | Output channel 6                       |
| 21  | NOUT5 | Output channel 5                       |
| 22  | NOUT4 | Output channel 4                       |
| 23  | NOUT3 | Output channel 3                       |
| 24  | NOUT2 | Output channel 2                       |
|     | TP    | Thermal-Pad                            |

The *Thermal Pad* is to be connected to a ground plane on the PCB. Connections between GND, GNDR and the ground plane should be conciled to system FMEA aspects.

# iC-MFP

## 8-FOLD FAIL-SAFE P-FET DRIVER

target specification



Rev A2, Page 4/13

### ABSOLUTE MAXIMUM RATINGS

Beyond these values damage may occur; device operation is not guaranteed.

| Item No. | Symbol  | Parameter   | Conditions                           | Limits |      | Unit |
|----------|---------|---|--------------------------------------|--------|------|------|
|          |         |   |                                      | Min.   | Max. |      |
| G001     | VB, VBR | Supply Voltage                                      |                                      | -0.3   | 40   | V    |
| G002     | V()     | Voltage at NOUT1...8, NOK                           |                                      | -0.3   | 40   | V    |
| G003     | V()     | Voltage at IN1...8, EN5, EN10, ENFS                 |                                      | -0.3   | 40   | V    |
| G004     | V(GNDR) | Voltage at GNDR referenced to GND                   |                                      | -0.3   | 0.3  | V    |
| G005     | V(GND)  | Voltage at GND referenced to GNDR                   |                                      | -0.3   | 0.3  | V    |
| G006     | V(VBR)  | Voltage at VBR referenced to VB                     |                                      | -0.3   | 0.3  | V    |
| G007     | V(VB)   | Voltage at VB referenced to VBR                     |                                      | -0.3   | 0.3  | V    |
| G008     | Imx()   | Current in NOUT1...8, NOK, IN1...8, EN5, EN10, ENFS |                                      | -10    | 10   | mA   |
| G009     | Imx()   | Current in VB, VBR                                  |                                      | -10    | 80   | mA   |
| G010     | Imx()   | Current in GND, GNDR                                |                                      | -80    | 10   | mA   |
| G011     | Vd()    | ESD susceptibility at all pins                      | HBM 100 pF discharged through 1.5 kΩ |        | 2    | kV   |
| G012     | Tj      | Operating Junction Temperature                      |                                      | -40    | 140  | °C   |
| G013     | Ts      | Storage Temperature Range                           |                                      | -55    | 125  | °C   |

### THERMAL DATA

Operating Conditions: VB = VBR = 4.5...40 V, GND = GNDR = 0 V

| Item No. | Symbol | Parameter                           | Conditions                                 | Limits |      |      | Unit |
|----------|--------|-------------------------------------|--|--------|------|------|------|
|          |        |                                     |  | Min.   | Typ. | Max. |      |
| T01      | Ta     | Operating Ambient Temperature Range |  | -40    |      | 125  | °C   |
| T02      | Rthja  | Thermal Resistance Chip/Ambient     | SMD assembly, no additional cooling areas. |        |      | 75   | K/W  |

All voltages are referenced to ground unless otherwise stated.

All currents into the device pins are positive; all currents out of the device pins are negative.

### ELECTRICAL CHARACTERISTICS

Operating Conditions: VB = VBR = 4.5...40 V, GND = GNDR = 0 V, Tj = -40...125 °C unless otherwise stated

| Item No.                        | Symbol    | Parameter   | Conditions   | Tj °C | Fig. |       |      |            | Unit   |
|---------------------------------|-----------|---|--|-------|------|-------|------|------------|--------|
|                                 |           |   |  |       |      | Min.  | Typ. | Max.       |        |
| <b>Total Device</b>             |           |   |  |       |      |       |      |            |        |
| 001                             | VB        | Permissible Supply Voltage                                    |  |       |      | 4.5   |      | 40         | V      |
| 002                             | I(VB)     | Supply Current in VB  | No load, EN5 = lo, EN10 = lo, ENFS = lo  |       |      | 1.2   |      | 3.6        | mA     |
| 003                             | I(VB)     | Supply Current in VB  | No load, EN5 = hi, EN10 = lo, ENFS = lo, IN1...8 = hi, VB = 8...40 V                 |       |      | 3.2   |      | 6.6        | mA     |
| 004                             | I(VB)     | Supply Current in VB  | No load, EN5 = lo, EN10 = hi, ENFS = lo, IN1...8 = hi, VB = 13...40 V                |       |      | 3.2   |      | 6.8        | mA     |
| 005                             | I(VB)     | Supply Current in VB  | No load, EN5 = lo, EN10 = lo, ENFS = hi, IN1...8 = hi, VB = 4.5...40 V               |       |      | 1.3   |      | 6.6        | mA     |
| 006                             | I(VBR)    | Supply Current in VBR   | No load, all NOUTx = lo  |       |      |       | tbd  |            | mA     |
| 007                             | I(GND)    | Current in GND  | No load  |       |      | -7    |      |            | mA     |
| 008                             | I(GNDR)   | Current in GNDR   | No load  |       |      |       | tbd  |            | mA     |
| <b>Current Driver NOUT1...8</b> |           |   |  |       |      |       |      |            |        |
| 101                             | Vc()hi    | Clamp Voltage hi  | I() = 10 mA  |       |      | 42    |      | 60         | V      |
| 102                             | Vc()lo    | Clamp Voltage lo referenced to the lower voltage of GND, GNDR | I() = -10 mA   |       |      | -2    |      | -0.4       | V      |
| 103                             | Vs()hi    | Saturation Voltage hi referenced to VB                        | Vs()hi = VB - V();<br>I() = -0.5 mA<br>I() = -2 mA                                   |       |      |       |      | 0.2<br>0.8 | V<br>V |
| 104                             | Vs()lo    | Saturation Voltage lo referenced to GND                       | ENFS = hi, INx = hi;<br>I() = 0.5 mA<br>I() = 2 mA                                   |       |      |       |      | 0.2<br>0.8 | V<br>V |
| 105                             | Vr()      | Output Voltage regulated, no load                             | Vr() = V() - VB, EN5 = hi, INx = hi, I() = 0 mA                                      |       |      | -5.3  | -5   | -4.7       | V      |
| 106                             | Vr()      | Output Voltage regulated, no load                             | Vr() = V() - VB, EN10 = hi, INx = hi, I() = 0 mA                                     |       |      | -10.6 | -10  | -9.4       | V      |
| 107                             | Ri()      | Output Resistance   | EN10 = hi or EN5 = hi, INx = hi, I() = ± 2 mA  |       |      | 80    |      | 300        | Ω      |
| 108                             | VI(NOUTx) | Output Voltage  | I(NOUTx) = -2 μA,<br>VI() = VBR - V(), VB open                                       |       |      |       |      | 600        | mV     |
| 109                             | Ipu()     | Pull-Up Current   | VBR - V(NOUTx) = 1 V, VB open  |       |      | -10   |      | -3         | μA     |
| 110                             | Rpu()     | Pull-Up Resistor at NOUTx referenced to VBR                   | VBR - V(NOUTx) = 10 V, VB open   |       |      | 140   | 200  | 300        | kΩ     |
| 111                             | Rpu()     | Pull-Up Resistor at NOUTx referenced to VBR                   | VBR - V(NOUTx) = 40 V, VB open   |       |      | 200   | 400  | 600        | kΩ     |
| 112                             | Isc()lo   | Short circuit current lo                                      | V() = 0.8 V...VB   |       |      | 2     | 3    | 10         | mA     |
| 113                             | Isc()hi   | Short circuit current hi                                      | V() = 0...VB - 0.8 V   |       |      | -10   | -3.6 | -2         | mA     |
| 114                             | Vsh()     | Output Voltage at short circuit of two outputs                | Vsh() = V() - VB; EN5 = hi<br>At two different input signals hi and lo               |       |      | -1    |      |            | V      |
| 115                             | Vsh()     | Output Voltage at short circuit of two outputs                | Vsh() = V() - VB; EN10 = hi or ENFS = hi<br>At two different input signals hi and lo |       |      | -1.3  |      |            | V      |
| 116                             | Vt()hi    | Threshold Voltage hi monitoring comparator                    | Vt() = Vr() + VB - V() or Vt() = V()   |       |      |       |      | 2.2        | V      |
| 117                             | Vt()lo    | Threshold Voltage lo monitoring comparator                    | Vt() = Vr() + VB - V() or Vt() = V()   |       |      | 0.8   |      |            | V      |
| 118                             | Vt()hys   | Hysteresis  | Vt()hys = Vt()hi - Vt()lo  |       |      | 50    |      | 300        | mV     |

## ELECTRICAL CHARACTERISTICS

Operating Conditions:  $V_B = V_{BR} = 4.5 \dots 40 \text{ V}$ ,  $GND = G_{NDR} = 0 \text{ V}$ ,  $T_j = -40 \dots 125 \text{ }^\circ\text{C}$  unless otherwise stated

| Item No.                                   | Symbol     | Parameter   | Conditions   | Tj °C | Fig. |      |      |            | Unit   |  |
|--|------------|---|--|-------|------|------|------|------------|--------|--|
|  |            |   |  |       |      | Min. | Typ. | Max.       |        |  |
| <b>Input IN1...8, EN5, EN10, ENFS</b>      |            |   |  |       |      |      |      |            |        |  |
| 201  | Vc()hi     | Clamp Voltage hi  | I() = 10 mA  |       |      | 42   |      | 60         | V      |  |
| 202  | Vc()lo     | Clamp Voltage lo referenced to the lower voltage of GND, G <sub>NDR</sub> | I() = -10 mA                                       |       |      | -2   |      | -0.4       | V      |  |
| 203  | Vt()hi     | Threshold Voltage hi  |  |       |      | 1.15 |      | 1.4        | V      |  |
| 204  | Vt()lo     | Threshold Voltage lo  |  |       |      | 0.8  |      | 1.05       | V      |  |
| 205  | Vt()hys    | Input Hysteresis  | Vt()hys = Vt()hi - Vt()lo                          |       |      | 200  |      | 400        | mV     |  |
| 206  | Ipd1()     | Pull-Down Current 1   | $0.4 \text{ V} < V() < Vt()hi$                     |       | 5    | 75   | 225  | 350        | µA     |  |
| 207  | Ipd2()     | Pull-Down Current 2   | V() > 1.4 V  |       | 5    | 20   | 45   | 70         | µA     |  |
| 208  | Cin()      | Input Capacitance   |  |       |      |      |      | 20         | pF     |  |
| 209  | Ii()       | Leakage Current   | $V_B, V_{BR} = 0 \text{ V}, V() = 0..40 \text{ V}$ |       |      | -10  |      | 10         | µA     |  |
| <b>Supply and Temperature Monitor</b>      |            |   |  |       |      |      |      |            |        |  |
| 301  | VBon       | Turn-On Threshold VB  |  |       |      | 3.8  |      | 4.3        | V      |  |
| 302  | VBoff      | Turn-Off Threshold VB   | Decreasing voltage VB                              |       |      | 3.4  |      | 4.0        | V      |  |
| 303  | VBhys      | Hysteresis  | VBhys = VBon - VBoff                               |       |      | 200  |      |            | mV     |  |
| 304  | Toff       | Turn-Off Temperature  | Increasing temperature                             |       |      | 145  | 160  | 180        | °C     |  |
| 305  | Ton        | Turn-On temperature   | Decreasing temperature                             |       |      | 130  | 147  | 170        | °C     |  |
| 306  | Thys       | Hysteresis  | Thys = Toff - Ton                                  |       |      |      | 13   |            | °C     |  |
| <b>Ground Monitor GND, G<sub>NDR</sub></b> |            |   |  |       |      |      |      |            |        |  |
| 401  | Vt()hi     | Threshold Voltage hi GND Monitor  | Referenced to G <sub>NDR</sub>                     |       |      |      |      | 270        | mV     |  |
| 402  | Vt()lo     | Threshold Voltage lo GND Monitor  | Referenced to G <sub>NDR</sub>                     |       |      | 50   |      |            | mV     |  |
| 403  | Vt()hys    | Hysteresis  | Vt()hys = Vt()hi - Vt()lo                          |       |      | 5    |      | 100        | mV     |  |
| 404  | Vt()hi     | Threshold Voltage hi G <sub>NDR</sub> Monitor                             | Referenced to GND                                  |       |      |      |      | 270        | mV     |  |
| 405  | Vt()lo     | Threshold Voltage lo G <sub>NDR</sub> Monitor                             | Referenced to GND                                  |       |      | 50   |      |            | mV     |  |
| 406  | Vt()hys    | Hysteresis  | Vt()hys = Vt()hi - Vt()lo                          |       |      | 10   |      | 100        | mV     |  |
| 407  | Vc()hi     | Clamp Voltage G <sub>NDR</sub> hi referenced to GND                       | I() = 1 mA   |       |      | 0.4  |      | 2          | V      |  |
| 408  | Vc()lo     | Clamp Voltage G <sub>NDR</sub> lo referenced to GND                       | I() = -1 mA  |       |      | -2   |      | -0.4       | V      |  |
| <b>Status Output NOK</b>                   |            |   |  |       |      |      |      |            |        |  |
| 501  | Vc(NOK)hi  | Clamp Voltage hi  | I() = 10 mA  |       |      | 42   |      | 60         | V      |  |
| 502  | Vc(NOK)lo  | Clamp Voltage lo referenced to the lower voltage of GND, G <sub>NDR</sub> | I() = -10 mA                                       |       |      | -2   |      | -0.4       | V      |  |
| 503  | Ii(NOK)    | Leakage Current   | $GND < V(NOK) < V_B$                               |       |      | -20  |      | 20         | µA     |  |
| 504  | Vs(NOK)lo  | Saturation Voltage lo referenced to GND                                   | I() = 0.5 mA<br>I() = 2 mA                         |       |      |      |      | 0.2<br>0.8 | V<br>V |  |
| 505  | Isc(NOK)lo | Short circuit current lo  | V() = 0.8 V...VB                                   |       |      | 2    | 3    | 10         | mA     |  |
| <b>Supply Monitor VB, VBR</b>              |            |   |  |       |      |      |      |            |        |  |
| 601  | Vt(VB)hi   | Threshold Voltage hi VB Monitor   | Referenced to VBR                                  |       |      |      |      | 270        | mV     |  |
| 602  | Vt(VB)lo   | Threshold Voltage lo VB Monitor   | Referenced to VBR                                  |       |      | 50   |      |            | mV     |  |
| 603  | Vt(VB)hys  | Hysteresis  | Vt()hys = Vt()hi - Vt()lo                          |       |      | 5    |      | 100        | mV     |  |
| 604  | Vt(VBR)hi  | Threshold Voltage hi VBR Monitor  | Referenced to VB                                   |       |      |      |      | 270        | mV     |  |
| 605  | Vt(VBR)lo  | Threshold Voltage lo VBR Monitor  | Referenced to VB                                   |       |      | 50   |      |            | mV     |  |
| 606  | Vt(VBR)hys | Hysteresis  | Vt()hys = Vt()hi - Vt()lo                          |       |      | 5    |      | 100        | mV     |  |
| 607  | Vc(VBR)hi  | Clamp Voltage hi  | I() = 1 mA, Vc() = V(VBR) - V(VB)                  |       |      | 0.4  |      | 2          | V      |  |
| 608  | Vc(VBR)lo  | Clamp Voltage lo  | I() = -1 mA, Vc() = V(VBR) - V(VB)                 |       |      | -2   |      | -0.4       | V      |  |

### ELECTRICAL CHARACTERISTICS

Operating Conditions:  $V_B = V_{BR} = 4.5 \dots 40 \text{ V}$ ,  $GND = G_{NDR} = 0 \text{ V}$ ,  $T_j = -40 \dots 125 \text{ }^\circ\text{C}$  unless otherwise stated

| Item No.                        | Symbol              | Parameter  | Conditions  | $T_j$ $^\circ\text{C}$ | Fig. | Min. | Typ. | Max. | Unit                   |
|---------------------------------|---------------------|--|---|------------------------|------|------|------|------|------------------------|
| <b>Testmode EN5, EN10, ENFS</b> |                     |  |   |                        |      |      |      |      |                        |
| 701                             | $V_t(\text{hi})$    | Threshold Voltage hi disable test                          | $EN5 = EN10 = ENFS$   |                        |      |      |      | -60  | mV                     |
| 702                             | $V_t(\text{lo})$    | Threshold Voltage lo enable test                           | $EN5 = EN10 = ENFS$   |                        |      | -320 |      |      | mV                     |
| 703                             | $V_t(\text{hys})$   | Hysteresis   | $V_t(\text{hys}) = V_t(\text{hi}) - V_t(\text{lo})$   |                        |      | 50   |      | 160  | mV                     |
| <b>Regulator lo-level</b>       |                     |  |   |                        |      |      |      |      |                        |
| 801                             | $V_t(V_B)\text{hi}$ | Threshold Voltage hi enable regulator                      | $EN5 = \text{hi}$   |                        |      | 5.5  |      | 6.2  | V                      |
| 802                             | $V_t(V_B)\text{lo}$ | Threshold Voltage lo disable regulator                     | $EN5 = \text{hi}$   |                        |      | 5.3  |      | 6    | V                      |
| 803                             | $V_t(\text{hys})$   | Hysteresis   | $V_t(\text{hys}) = V_t(\text{hi}) - V_t(\text{lo})$   |                        |      | 100  |      | 300  | mV                     |
| 804                             | $V_t(V_B)\text{hi}$ | Threshold Voltage hi enable regulator                      | $EN10 = \text{hi}$  |                        |      | 10.6 |      | 11.7 | V                      |
| 805                             | $V_t(V_B)\text{lo}$ | Threshold Voltage lo disable regulator                     | $EN10 = \text{hi}$  |                        |      | 10.3 |      | 11.3 | V                      |
| 806                             | $V_t(\text{hys})$   | Hysteresis   | $V_t(\text{hys}) = V_t(\text{hi}) - V_t(\text{lo})$   |                        |      | 200  |      | 600  | mV                     |
| <b>Timing</b>                   |                     |  |   |                        |      |      |      |      |                        |
| 901                             | $t_p(\text{NOUTx})$ | Propagation delay<br>$IN_x, EN5 \rightarrow \text{NOUTx}$  | $\{(IN, EN5)\text{lo} \rightarrow \text{hi}\} \rightarrow 10\% \text{NOUT}$<br>$\{(IN, EN5)\text{hi} \rightarrow \text{lo}\} \rightarrow 90\% \text{NOUT}$<br>$C_{Load}() = 100 \text{ pF}$   |                        | 1    | 0.45 |      | 1.1  | $\mu\text{s}$          |
| 902                             | $t_p(\text{NOUTx})$ | Propagation delay<br>$IN_x, EN5 \rightarrow \text{NOUTx}$  | $\{(IN, EN5)\text{lo} \rightarrow \text{hi}\} \rightarrow 10\% \text{NOUT}$<br>$\{(IN, EN5)\text{hi} \rightarrow \text{lo}\} \rightarrow 90\% \text{NOUT}$<br>$C_{Load}() = 1 \text{ nF}$     |                        | 1    | 1.3  |      | 2.4  | $\mu\text{s}$          |
| 903                             | $t_p(\text{NOUTx})$ | Propagation delay<br>$IN_x, EN5 \rightarrow \text{NOUTx}$  | $\{(IN, EN5)\text{lo} \rightarrow \text{hi}\} \rightarrow 10\% \text{NOUT}$<br>$\{(IN, EN5)\text{hi} \rightarrow \text{lo}\} \rightarrow 90\% \text{NOUT}$<br>$C_{Load}() = 2 \text{ nF}$     |                        | 1    | 2.2  |      | 3.7  | $\mu\text{s}$          |
| 904                             | $t_p(\text{NOUTx})$ | Propagation delay<br>$IN_x, EN5 \rightarrow \text{NOUTx}$  | $\{(IN, EN5)\text{lo} \rightarrow \text{hi}\} \rightarrow 10\% \text{NOUT}$<br>$\{(IN, EN5)\text{hi} \rightarrow \text{lo}\} \rightarrow 90\% \text{NOUT}$<br>$C_{Load}() = 5 \text{ nF}$     |                        | 1    | 5    |      | 8.1  | $\mu\text{s}$          |
| 905                             | $t_p(\text{NOUTx})$ | Propagation delay<br>$IN_x, EN10 \rightarrow \text{NOUTx}$ | $\{(IN, EN10)\text{lo} \rightarrow \text{hi}\} \rightarrow 10\% \text{NOUT}$<br>$\{(IN, EN10)\text{hi} \rightarrow \text{lo}\} \rightarrow 90\% \text{NOUT}$<br>$C_{Load}() = 100 \text{ pF}$ |                        | 1    | 0.7  |      | 1.6  | $\mu\text{s}$          |
| 906                             | $t_p(\text{NOUTx})$ | Propagation delay<br>$IN_x, EN10 \rightarrow \text{NOUTx}$ | $\{(IN, EN10)\text{lo} \rightarrow \text{hi}\} \rightarrow 10\% \text{NOUT}$<br>$\{(IN, EN10)\text{hi} \rightarrow \text{lo}\} \rightarrow 90\% \text{NOUT}$<br>$C_{Load}() = 1 \text{ nF}$   |                        | 1    | 2.3  |      | 4.1  | $\mu\text{s}$          |
| 907                             | $t_p(\text{NOUTx})$ | Propagation delay<br>$IN_x, EN10 \rightarrow \text{NOUTx}$ | $\{(IN, EN10)\text{lo} \rightarrow \text{hi}\} \rightarrow 10\% \text{NOUT}$<br>$\{(IN, EN10)\text{hi} \rightarrow \text{lo}\} \rightarrow 90\% \text{NOUT}$<br>$C_{Load}() = 2 \text{ nF}$   |                        | 1    | 3.9  |      | 7.1  | $\mu\text{s}$          |
| 908                             | $t_p(\text{NOUTx})$ | Propagation delay<br>$IN_x, EN10 \rightarrow \text{NOUTx}$ | $\{(IN, EN10)\text{lo} \rightarrow \text{hi}\} \rightarrow 10\% \text{NOUT}$<br>$\{(IN, EN10)\text{hi} \rightarrow \text{lo}\} \rightarrow 90\% \text{NOUT}$<br>$C_{Load}() = 5 \text{ nF}$   |                        | 1    | 9    |      | 16   | $\mu\text{s}$          |
| 909                             | $t_p(\text{NOUTx})$ | Propagation delay<br>$IN_x, ENFS \rightarrow \text{NOUTx}$ | $\{(IN, ENFS)\text{lo} \rightarrow \text{hi}\} \rightarrow 10\% \text{NOUT}$<br>$\{(IN, ENFS)\text{hi} \rightarrow \text{lo}\} \rightarrow 90\% \text{NOUT}$<br>$C_{Load}() = 100 \text{ pF}$ |                        | 1    | 1.4  |      | 3.1  | $\mu\text{s}$          |
| 910                             | $t_p(\text{NOUTx})$ | Propagation delay<br>$IN_x, ENFS \rightarrow \text{NOUTx}$ | $\{(IN, ENFS)\text{lo} \rightarrow \text{hi}\} \rightarrow 10\% \text{NOUT}$<br>$\{(IN, ENFS)\text{hi} \rightarrow \text{lo}\} \rightarrow 90\% \text{NOUT}$<br>$C_{Load}() = 1 \text{ nF}$   |                        | 1    | 5.2  |      | 9.8  | $\mu\text{s}$          |
| 911                             | $t_p(\text{NOUTx})$ | Propagation delay<br>$IN_x, ENFS \rightarrow \text{NOUTx}$ | $\{(IN, ENFS)\text{lo} \rightarrow \text{hi}\} \rightarrow 10\% \text{NOUT}$<br>$\{(IN, ENFS)\text{hi} \rightarrow \text{lo}\} \rightarrow 90\% \text{NOUT}$<br>$C_{Load}() = 2 \text{ nF}$   |                        | 1    | 9.2  |      | 16.7 | $\mu\text{s}$          |
| 912                             | $t_p(\text{NOUTx})$ | Propagation delay<br>$IN_x, ENFS \rightarrow \text{NOUTx}$ | $\{(IN, ENFS)\text{lo} \rightarrow \text{hi}\} \rightarrow 10\% \text{NOUT}$<br>$\{(IN, ENFS)\text{hi} \rightarrow \text{lo}\} \rightarrow 90\% \text{NOUT}$<br>$C_{Load}() = 5 \text{ nF}$   |                        | 1    | 20   |      | 35   | $\mu\text{s}$          |
| 913                             | $dV()/dt$           | Slew rate  | $V_B = 24 \text{ V}, C_{Load}() = 100 \text{ pF}$   |                        |      | 7    |      | 18   | $\text{V}/\mu\text{s}$ |
| 914                             | $dV()/dt$           | Slew rate  | $V_B = 24 \text{ V}, C_{Load}() = 1 \text{ nF}$   |                        |      | 2.2  |      | 4.5  | $\text{V}/\mu\text{s}$ |
| 915                             | $dV()/dt$           | Slew rate  | $V_B = 24 \text{ V}, C_{Load}() = 2 \text{ nF}$   |                        |      | 1.2  |      | 2.5  | $\text{V}/\mu\text{s}$ |
| 916                             | $dV()/dt$           | Slew rate  | $V_B = 24 \text{ V}, C_{Load}() = 5 \text{ nF}$   |                        |      | 0.5  |      | 1.2  | $\text{V}/\mu\text{s}$ |

### ELECTRICAL CHARACTERISTICS: Diagrams

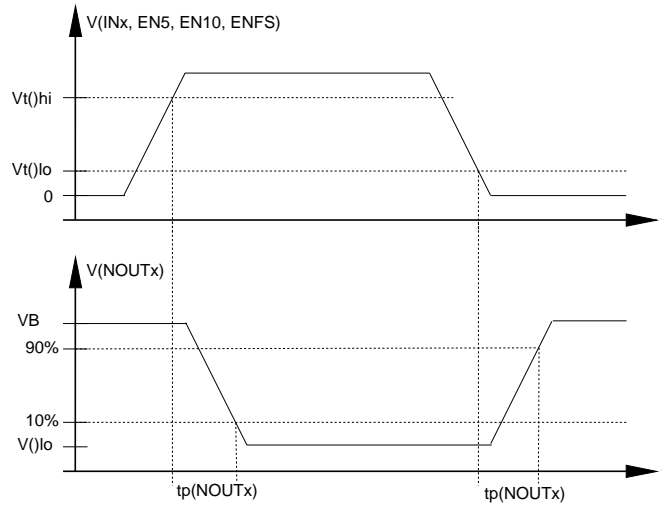

Figure 1: Propagation delays

### DESCRIPTION OF FUNCTIONS

#### Lo-level output configuration

The device iC-MFP has three adjustable lo-levels for driving P-channel fets. The configured lo-level is common to all outputs NOUTx and the minimum level is GND potential. The lo-level configuration inputs are used simultaneous for enabling the lo-level at the outputs NOUTx. The hi-level at exactly one input EN5, EN10 or ENFS configure the voltage of lo-level and enable the outputs. If more than one of these inputs have hi-level the outputs remains disabled. The lo-level VB - 5 V (configured with EN5 = hi) and VB - 10 V (configured with EN10 = hi) are internally generated by a voltage reference and regulated. The lo-level GND (configured with ENFS = hi) is an unregulated connection to GND. In this case the voltage swing depends directly from the power supply VB.

#### Output characteristics of the highside transistor

The highside output transistors at the eight channels demonstrate a resistive behavior with low voltage ( $V_B - V(NOUTx)$ ) and behave as a current source with finite output resistance with higher voltages.

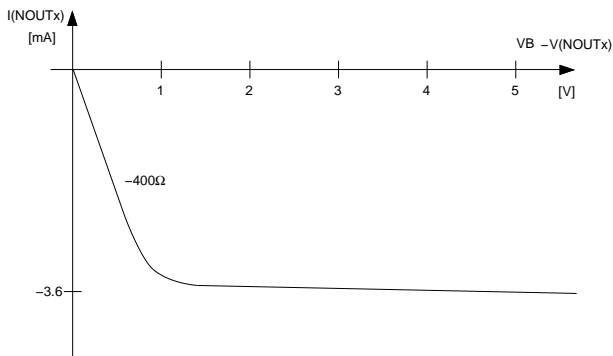

Figure 2: Output characteristic of the highside transistor at NOUTx

#### Output characteristic of the regulated push-pull-output at NOUTx

The lo-level VB - 5 V and VB - 10 V is generated with a regulated push-pull output and demonstrate a resistive behavior with low voltage changes and behave as a current source with finite output resistance with higher voltage changes.

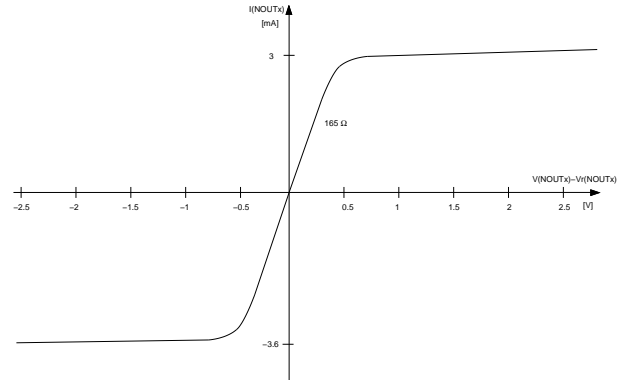

Figure 3: Output characteristic of the regulated push-pull-output at NOUTx

#### Output characteristic of the lowside transistor

The lowside output transistors at the eight channels demonstrate a resistive behavior with low voltage  $V(NOUTx)$  and behave as a current sink with finite output resistance with higher voltages.

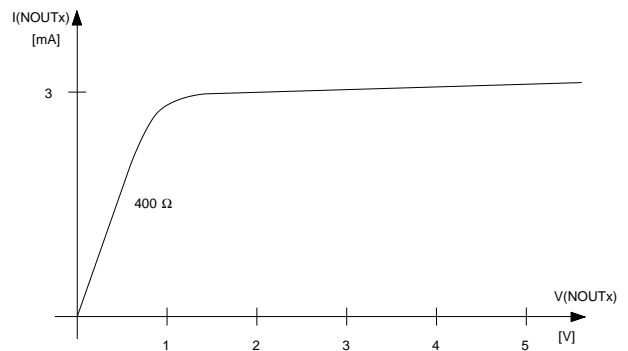

Figure 4: Output characteristic of the lowside transistor at NOUTx

#### Status output NOK

The status output NOK is a current limited 40 V proof open-drain output. The output transistor is switched on if the lo-level of the outputs NOUTx are enabled with exactly one pin ENx, the outputs have reached the voltage levels defined by the inputs INx, the power supply voltage is above the power-on threshold, the temperature is below the switch off temperature and all power supply pins are connected.

# iC-MFP

## 8-FOLD FAIL-SAFE P-FET DRIVER

target specification



Rev A2, Page 10/13

### Pull-down currents

In order to enhance noise immunity with limited power dissipation at inputs INx, EN5, EN10 and ENFS the pull-down currents at these pins have two stages. With a rise in voltage at input pins INx, EN5, EN10 and ENFS the pull-down current remains high until  $V_t(hi)$  (Electrical Characteristics No. 203); above this threshold the device switches to a lower pull-down current. If the voltage falls below  $V_t(lo)$  (Electrical Characteristics No. 204), the device switches back to a higher pull-down current.

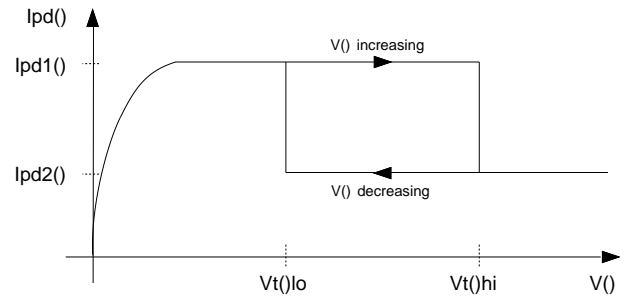

Figure 5: Pull-down currents at INx, EN5, EN10 and ENFS

## DETECTING SINGLE ERRORS

If single errors are detected, safety-relevant applications require externally connected switching transistors to be specifically shut down. Single errors can occur when a pin is open (due to a disconnected bonding wire or a bad solder connection, for example) or when two pins are short-circuited.

When two output of different logic levels are short-circuited, the driving capability of the highside driver will predominate, keeping the connected P-channel FETs in a safe shutdown state.

With open pins VB, VBR, GND or GNDR iC-MFP switches the output stages to a safe, predefined high state via pull-up resistors and current sources at the outputs, subsequently shutting down any externally connected P-channel FETs.

### Loss of VBR potential

If power supply potential is no longer applied to the VBR-pin, the output stage lowside drivers are shut down and the outputs actively tied to VB via the highside drivers.

### Loss of GND potential

If ground potential is no longer applied to the GND-pin, the output stage lowside drivers are shut down and the outputs actively tied to VB via the highside drivers.

### Loss of GNDR potential

If ground potential is no longer applied to the GNDR-pin, the output stage lowside drivers are shut down and the outputs actively tied to VB via the highside drivers.

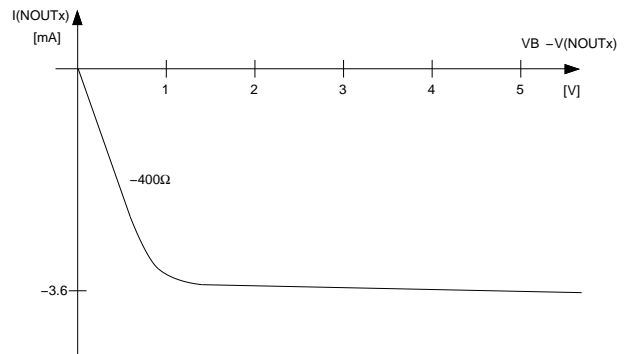

Figure 6: Output characteristics at NOUTx with loss of VBR, GND or GNDR

### Loss of VB potential

If power supply potential is no longer applied to VB, the output stages are shut down and the outputs tied to VBR via internal pull-up resistors with a typical value of 200 kΩ.

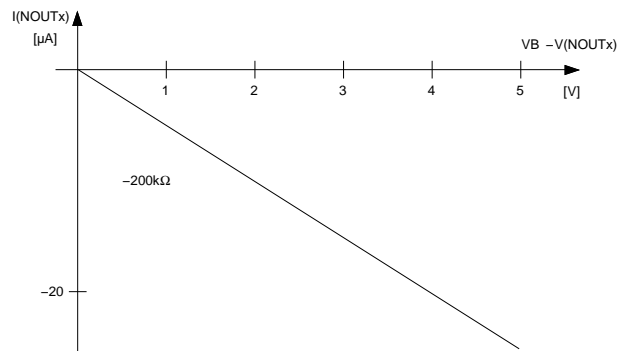

Figure 7: Output characteristics at NOUTx with loss of VB

### APPLICATION NOTES

#### Driving an P-channel MOSFET

One typical field of application for iC-MFP is in the operation of P-FETs with microprocessor output signals, as shown in Figure 8.

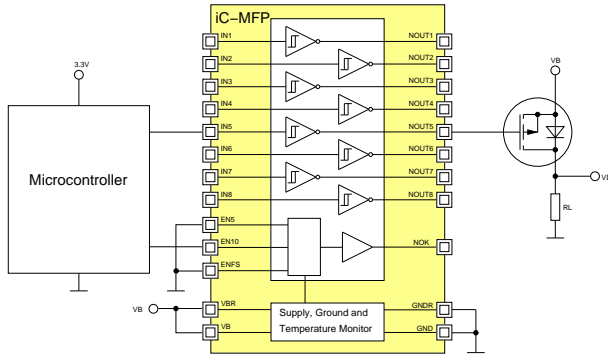

Figure 8: Driving an P-channel MOSFET

Slowly switching of a transistor is done with a current limited driver. Figure 9 shows the different phases of a turn on process with resistive load. In Section t0 to t1 the gate of the transistors is loaded to the threshold voltage  $V_{th}(FET)$  and is a dead time. In section t1 to t2 the gate voltage keeps nearly constant (miller-plateau) during the drain voltage slope. The slew rate is depending on the current of the driver and the gate-drain capacitor of the transistor. In section t2 to t3 the gate voltage reach the static value. The transistor thus goes low ohmic and minimizes the power dissipation. The equations 1 to 4 are simplified and give an estimation of the timing on the basis of data from the specifications of the device iC-MFP and the used transistor. The turn off looks similar to the turn on but with reverse run trough.

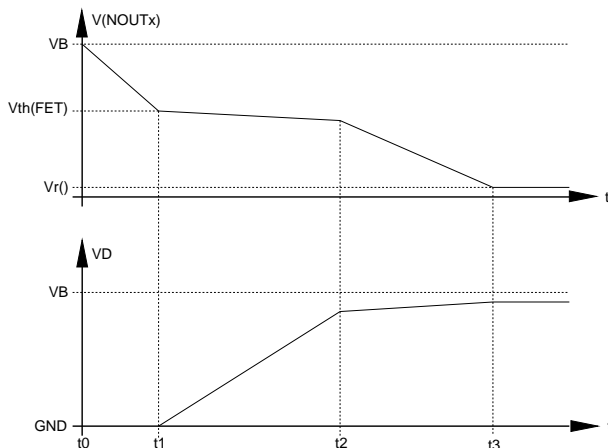

Figure 9: On switching of a transistor

$$t_{t0..t1}[\mu s] = C_{iss} @ (V_{ds} = hi) \times \frac{V_{th}(FET)}{-I_{sc}(NOUTx)lo} \quad (1)$$

$$t_{t1..t2}[\mu s] = C_{rss} @ (V_{ds} = hi) \times \frac{VB}{-I_{sc}(NOUTx)lo} \quad (2)$$

$$t_{t2..t3}[\mu s] = C_{iss} @ (V_{ds} = lo) \times \frac{V_r(NOUTx) - V_{th}(FET)}{-I_{sc}(NOUTx)lo} \quad (3)$$

$$t_{on} = t_{t0..t1} + t_{t1..t2} + t_{t2..t3} \quad (4)$$

$C_{iss} = C_{gs} + C_{gd}$  = voltage dependent gate-source and gate-drain capacitor [nF]

$C_{rss} = C_{gd}$  = voltage dependent gate-drain capacitor [nF]

$I_{sc}(NOUTx)lo$  = short circuit current lo at NOUTx [mA]

$t_{t0..t1}$  = dead time [ $\mu s$ ]

$t_{t1..t2}$  = slope time at drain (Miller-Plateau) [ $\mu s$ ]

$t_{t2..t3}$  = time to reach static gate voltage [ $\mu s$ ]

$t_{on}$  = overall turn on time [ $\mu s$ ]

$VB$  = power supply VB [V]

$V_r(NOUTx)$  = configured static turn on voltage at NOUTx [V]

$V_{th}(FET)$  = threshold of the transistor [V]

### Example

Turn on calculation with following estimations:

$$C_{iss} @ (V_{ds} = -24 V) = 1.5 \text{ nF}$$

$$C_{iss} @ (V_{ds} = -1 V) = 3 \text{ nF}$$

$$C_{rss} @ (V_{ds} = -24 V) = 0.3 \text{ nF}$$

$$I_{sc}(NOUT_x)_{lo} = 4 \text{ mA}$$

$$VB = 24 V$$

$$V_r(NOUT_x) = -10 V$$

$$V_{th}(FET) = -3 V$$

From this follows:

$$t_{t0..t1} = 1.13 \mu s$$

$$t_{t1..t2} = 1.8 \mu s$$

$$t_{t2..t3} = 5.25 \mu s$$

$$t_{on} = 8.18 \mu s$$

The slew rate at the drain of transistor is:  $13.3 V/\mu s$

Figure 10 shows the turn on and off at one channel with pin INx. The pulse duration at pin NOK, especially at turn on, can be used for monitoring the connected transistor and the load.

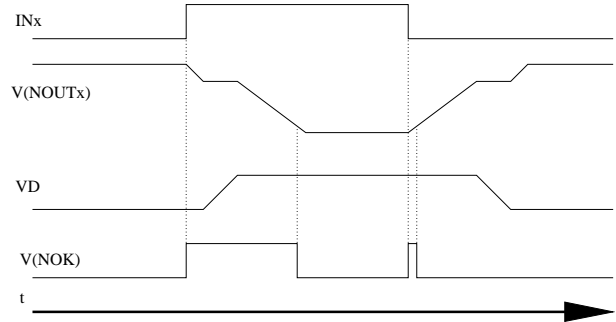

Figure 10: Turn on and off one channel with INx

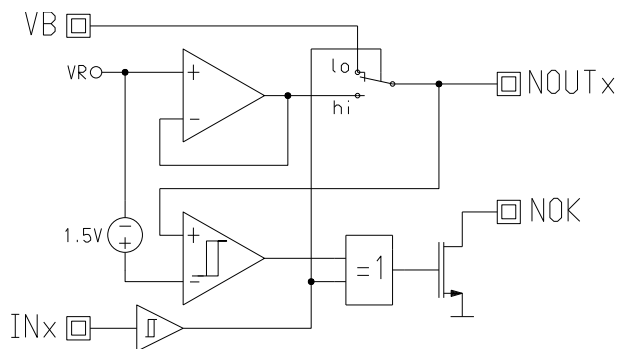

Figure 11: Circuit diagram one channel with monitoring comparator

This specification is for a newly developed product. iC-Haus therefore reserves the right to change or update, without notice, any information contained herein, design and specification; and to discontinue or limit production or distribution of any product versions. Please contact iC-Haus to ascertain the current data. Copying – even as an excerpt – is only permitted with iC-Haus approval in writing and precise reference to source.

iC-Haus does not warrant the accuracy, completeness or timeliness of the specification on this site and does not assume liability for any errors or omissions in the materials. The data specified is intended solely for the purpose of product description. No representations or warranties, either express or implied, of merchantability, fitness for a particular purpose or of any other nature are made hereunder with respect to information/specification or the products to which information refers and no guarantee with respect to compliance to the intended use is given. In particular, this also applies to the stated possible applications or areas of applications of the product.

iC-Haus conveys no patent, copyright, mask work right or other trade mark right to this product. iC-Haus assumes no liability for any patent and/or other trade mark rights of a third party resulting from processing or handling of the product and/or any other use of the product.

# iC-MFP

## 8-FOLD FAIL-SAFE P-FET DRIVER

target specification



Rev A2, Page 13/13

### ORDERING INFORMATION

| Type   | Package    | Order Designation |
|--------|------------|-------------------|
| iC-MFP | QFN24 4 mm | iC-MFP QFN24      |

For technical support, information about prices and terms of delivery please contact:

**iC-Haus GmbH**  
Am Kuemmerling 18  
D-55294 Bodenheim  
GERMANY

**Tel.: +49 (61 35) 92 92-0**  
**Fax: +49 (61 35) 92 92-192**  
**Web: <http://www.ichaus.com>**  
**E-Mail: [sales@ichaus.com](mailto:sales@ichaus.com)**

Appointed local distributors: [http://www.ichaus.de/support\\_distributors.php](http://www.ichaus.de/support_distributors.php)