

iC-DXC3

DIGITAL SENSOR I/O DRIVER

FEATURES

- ◆ Configurable high-side, low-side and push-pull operation
- ◆ 200 mA output current
- ◆ I/O-Link compliant
- ◆ 5 μ s input filter for spike suppression
- ◆ Reverse polarity protection
- ◆ Current limited output (< 450 mA)
- ◆ Wide supply voltage range from 8 to 30 V
- ◆ Driver shut-down with over temperature
- ◆ Integrated free-wheeling diode for inductive loads
- ◆ Sensor supply voltage output of 3.3 V at 10 mA

APPLICATIONS

- ◆ Digital sensors
- ◆ Light barriers
- ◆ Proximity switches

PACKAGES

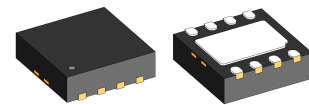

DFN8 3x3

BLOCK DIAGRAM

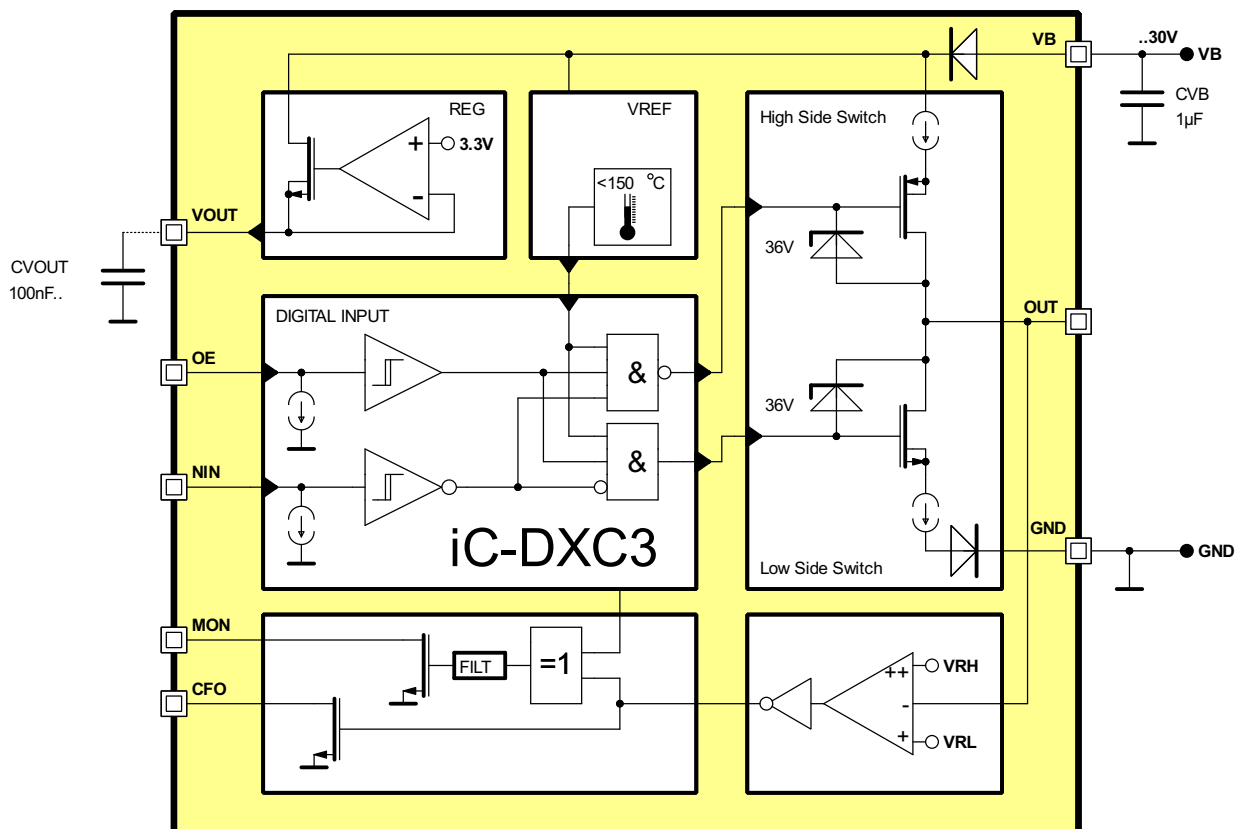

iC-DXC3

DIGITAL SENSOR I/O DRIVER

DESCRIPTION

The iC-DXC3 is a simple I/O circuit capable of driving ohmic, inductive and capacitive loads and features integrated reverse polarity protection.

The output current is at least 200 mA from a supply voltage of 8 to 30 V.

With input OE = high the output works as a push-pull driver controlled by pin NIN. If pin NIN is set either to low or high, the output acts as a high-side (PNP) or low-side (NPN) driver respectively, controlled by the input OE.

Forcing the output pin OUT from his current state is signaled at pin MON. This can be used to implement an IO-Link Wake-Up detection.

Output transitions are slew-rate limited to reduce interference.

The output is current limited to 450 mA and short circuit proof by shutting down the driver with excessive temperature.

A regulated 3.3 V low power supply is available at pin VOUT to supply external circuitry with up to 10 mA.

PACKAGING INFORMATION DFN8 3x3

PIN CONFIGURATION

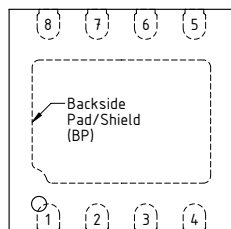

PIN FUNCTIONS

No.	Name	Function
1	VOUT	Regulated +3.3 V Voltage
2	MON	Monitor Output
3	GND	Ground
4	NIN	Input
5	OE	Output Enabled
6	CFO	Feedback Channel Output
7	OUT	Driver Output
8	VB	Supply Voltage

iC-DXC3

DIGITAL SENSOR I/O DRIVER

PACKAGE DIMENSIONS

All dimensions given in mm.

RECOMMENDED PCB-FOOTPRINT

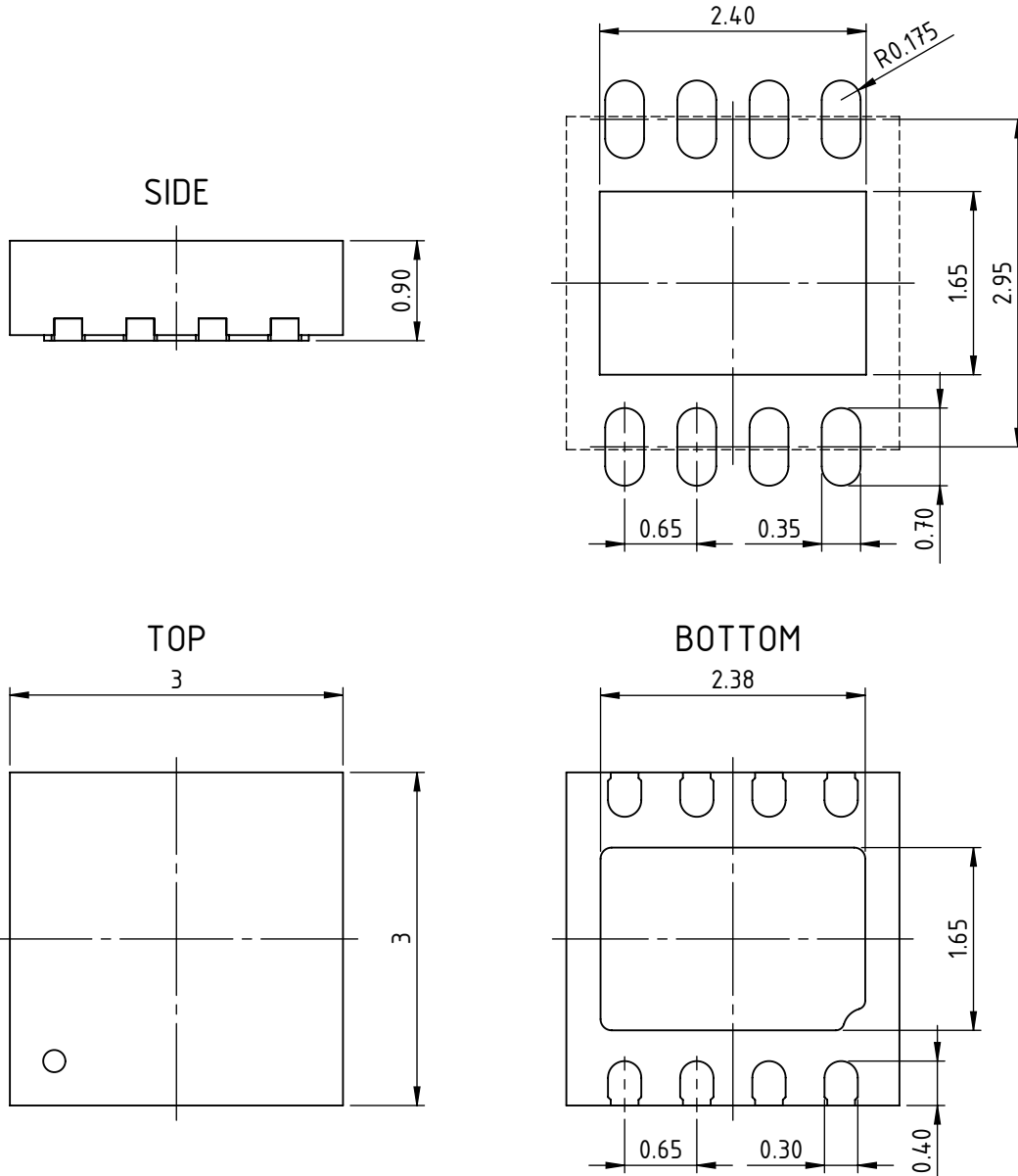

iC-DXC3

DIGITAL SENSOR I/O DRIVER



Rev A1, Page 4/12

ABSOLUTE MAXIMUM RATINGS

Beyond these values damage may occur; device operation is not guaranteed. Absolute Maximum Ratings are no operating conditions! Integrated circuits with system interfaces, e.g. via cable accessible pins (I/O pins, line drivers) are per principle endangered by injected interferences, which may compromise the function or durability. The robustness of the devices has to be verified by the user during system development with regards to applying standards and ensured where necessary by additional protective circuitry. By the manufacturer suggested protective circuitry is for information only and given without responsibility and has to be verified within the actual system with respect to actual interferences.

Item No.	Symbol	Parameter	Conditions	Limits		Unit
				Min.	Max.	
G001	VB	Supply Voltage	Referenced to lowest voltage of GND, OUT Referenced to highest voltage of GND, OUT	-36	36	V V
G002	OUT	OUT Voltage	Referenced to lowest voltage of VB, GND Referenced to highest voltage of VB, GND	-36	36	V V
G003	GND	GND Voltage	Referenced to lowest voltage of VB, OUT Referenced to highest voltage of VB, OUT	-36	36	V V
G004	V()	Voltage at MON, NIN, OE, CFO		-0,3	7	V
G005	Es()	Maximum Surge Energy as indication for external protection design	Single pulse test between each pins of VB, OUT or GND. Pulse magnitude less than 55 V, duration less than 100 μ s		6.5	mJ
G006	Vd()	ESD Susceptibility at all pins	HBM, 100 pF discharged through 1.5 k Ω		2	kV
G007	Tj	Junction Temperature		-40	150	°C
G008	Ts	Storage Temperature		-40	150	°C

THERMAL DATA

Operating Conditions: VB = 8..30 V

Item No.	Symbol	Parameter	Conditions	Limits			Unit
				Min.	Typ.	Max.	
T01	Ta	Operating Ambient Temperature Range	no thermal shutdown	-40		+150	°C

All voltages are referenced to ground unless otherwise stated.

All currents flowing into the device pins are positive; all currents flowing out of the device pins are negative.

iC-DXC3

DIGITAL SENSOR I/O DRIVER



Rev A1, Page 5/12

ELECTRICAL CHARACTERISTICS

Operating Conditions: $V_B = 8...30\text{ V}$, $T_j = -40...150\text{ °C}$, unless otherwise stated

Item No.	Symbol	Parameter	Conditions				Unit
				Min.	Typ.	Max.	
Total Device							
001	Vc(I)lo	Clamp Voltage I _o at NIN, OE, VOUT	I() = -1 mA	-1.4			V
002	VB	Permissible Supply Voltage	Referenced to GND	8	24	30	V
003	I(VB)	Supply Current in VB	no load, NIN = hi, OE = lo NIN = hi, OE = hi NIN = lo, OE = hi			1.2 1.4 1.6	mA mA mA
004	V(VB)on	Turn-on threshold	increasing VB	6		8	V
005	Ilk(GND)rp	Reverse Polarity Leakage Current	V(VB) = 0; V(OUT) = 0; V(GND) = 0...30 V			300	µA
006	Ilk(OUT)rp	Reverse Polarity Leakage Current	V(VB)=0;V(GND)=0; V(OUT)= 0...30 V			300	µA
007	Ilk(VB)rp	Reverse Polarity Leakage Current	V(OUT) = 0 ; GND open; ; V(VB)= 0...30 V			300	µA
Output characteristics							
101	Vs(OUT)lo	Saturation voltage Low-Side driver	NIN = hi, OE = hi I(OUT) = 100 mA I(OUT) = 200 mA			1.6 2.2	V V
102	Vs(OUT)hi	Saturation voltage High-Side driver	NIN = lo, OE = hi I(OUT) = -100 mA I(OUT) = -200 mA	-1.6 -2.2			V V
103	Isc(I)lo	Short-Circuit Current I _o in OUT	V(OUT) = 3...VB	200		450	mA
104	Isc(I)hi	Short-Circuit Current Hi in OUT	V() = 0...VB - 3 V	-450		-200	mA
105	Ilk()	Leakage Current at OUT	OUTPUT Disabled V(OUT) = -6...0 V V(OUT) = 0...VB V(OUT) > VB...30 V	-100 -40 0		0 40 100	µA µA µA
106	SR()	Slew Rate (switch off → on, switch on → off)	VB = 30 V, CI = 2.2 nF, I(OUT) = 0			40	V/µs
107	Vfw(OUT)lo	Freewheeling Voltage	I(OUT) = -1 mA, with reference to VB	-47		-36	V
108	Vfw(OUT)hi	Freewheeling Voltage	I(OUT) = 1 mA, with reference to GND	36		47	V
Temperature Monitor							
201	Toff	Over-temperature shutdown	increasing T _j	151		185	°C
202	Ton	Overtemperature release	decreasing T _j	150		180	°C
203	Thys	Thermal Shutdown Hysteresis			5		°C
Inputs OE, NIN							
301	Vt()hi	Input Threshold Voltage hi at NIN, OE				2	V
302	Vt()lo	Input Threshold Voltage I _o at NIN, OE		0.8			V
303	Vt()hys	Hysteresis at NIN, OE	Vt()hys = Vt()hi - Vt()lo	200			mV
304	Ipd()	Pull-Down Current at NIN, OE	V() > 0.6 V	2		150	µA
305	tpio	Propagation Delay NIN, OE → OUT		2.1		6.5	µs
306	tsup()	Permissible Spurious Pulse Width at NIN, OE				1.6	µs
307	ttrig()	Required Pulse Width at NIN, OE		4			µs
REG Series Regulator							
401	V(VOUT)	Regulated output voltage	VB = 8...30 V, I(VOUT) = 10...0 mA	3		3.5	V
402	C(VOUT)	Capacitor at VOUT	I(VOUT) = 0 I(VOUT) > 0	0 0.1		10 10	µF µF

iC-DXC3

DIGITAL SENSOR I/O DRIVER

preliminary



Rev A1, Page 6/12

ELECTRICAL CHARACTERISTICS

Operating Conditions: $V_B = 8...30\text{ V}$, $T_j = -40...150\text{ °C}$, unless otherwise stated

Item No.	Symbol	Parameter	Conditions	Min.	Typ.	Max.	Unit
403	Isc(VOUT)	Short circuit current at VOUT	VOUT connected to GND			-125	mA

iC-DXC3

DIGITAL SENSOR I/O DRIVER



Rev A1, Page 7/12

ELECTRICAL CHARACTERISTICS

Operating Conditions: $V_B = 8...30\text{ V}$, $T_j = -40...150\text{ °C}$, unless otherwise stated

Item No.	Symbol	Parameter	Conditions				Unit
				Min.	Typ.	Max.	
Feedback Channel							
501	Vt1(OUT)hi	Input Threshold 1 hi at OUT	$V_B < 18\text{ V}$	59	66	74	%VBR
502	Vt1(OUT)lo	Input Threshold 1 lo at OUT	$V_B < 18\text{ V}$	44	50	56	%VBR
503	Vt2(OUT)hi	Input Threshold 2 hi at OUT	$V_B > 18\text{ V}$	10	11.3	12.5	V
504	Vt2(OUT)lo	Input Threshold 2 lo at OUT	$V_B > 18\text{ V}$	8.3	9	10.5	V
505	Vt()hys	Hysteresis	$V_t(\text{OUT})_{\text{hys}} = V_t(\text{OUT})_{\text{hi}} - V_t(\text{OUT})_{\text{lo}}$	1			V
506	tpcf	Propagation Delay OUT → CFO	$V(\text{CFO}) = 10 \leftrightarrow 90\%$	1		5	μs
507	Vs()lo	Saturation Voltage lo at CFO/MON	$I(\text{CFO}/\text{MON}) = 1.0\text{ mA}$			0.4	V
508	Isc()lo	Short Circuit Current lo in CFO/MON	$V(\text{CFO}/\text{MON}) = 0.4\text{ V}...V_{\text{OUT}}$	1		65	mA
509	Iik()	Leakage Current at CFO	Open collector mode, $V(\text{CFO}) = 0\text{ V}...V_{\text{OUT}}$, CFO = off	-10		10	μA
510	tdre	Propagation Delay OUT → MON	Short-circuit	5.5		14	us

DESCRIPTION OF FUNCTIONS

iC-DXC3 is a current limited switching channel which enables digital sensors to drive peripheral elements. They are designed to cope with high driver currents. The switches are reverse-polarity protected, feature a free-wheeling circuit for inductive loads, and a current limited output.

Reverse polarity protection

The pins VB, OUT and GND on the *line side* of the chip are reverse polarity protected. As far as the maximum voltage ratings are not exceeded, no possible supply combination at the *line side* pins can damage the chip.

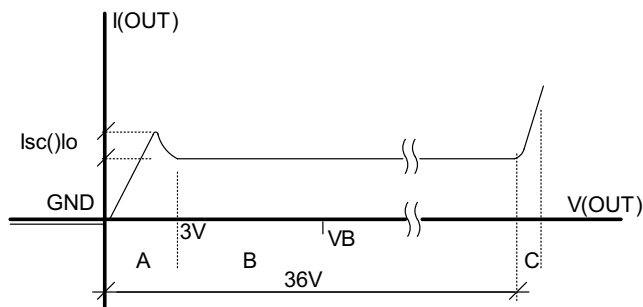

Figure 1: OUT characteristic when Low side active

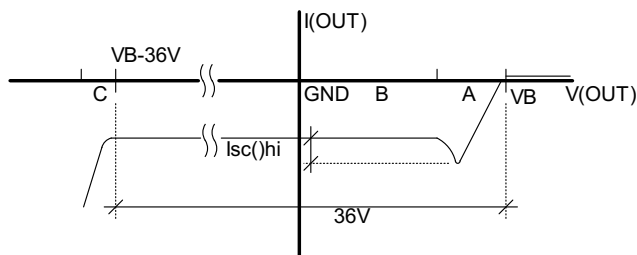

Figure 2: OUT characteristic when high side active

Output characteristics of OUT

The switching channel is current limited to a value between 150mA and 450mA. (cf. Electrical Characteristics Nos. 103, 104). The current limitation works only for voltages higher than 3V at OUT resp. lower than $V_{BO} - 3V$. For smaller output voltages the current limitation is reduced in order to minimize the saturation voltages without increasing the power dissipation. Figures 1 and 2 show the characteristic of the switching channels when activated. Region "A" is the saturation range, where the current limitation is not fully active yet and region "B" is the current limited range. Region "C" corresponds to the free-wheeling circuit activated. The switching channel is designed so that the low side can only sink current and high side can only source current (no reverse current).

Free-wheeling circuit for inductive loads

The free-wheeling circuit is always present and does not depend on the current output status. It is activated by voltages higher than 36V at OUT referenced to GND or lower than -36V at OUT referenced to VB. In that case the correspondent channel will switch on without current limitation (see Figure 3).

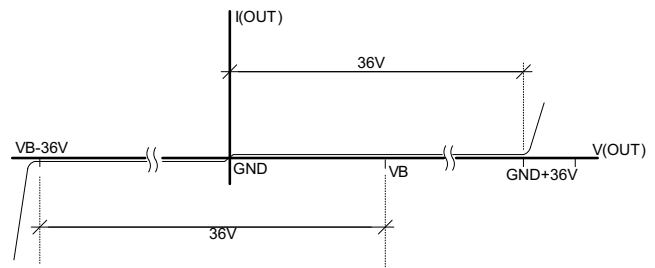

Figure 3: Free-wheeling characteristic

iC-DXC3

DIGITAL SENSOR I/O DRIVER

OPERATING MODES

The iC-DXC3 can be operated in high-side (PNP), low-side (NPN) and push-pull (PP) switch mode. Figure 4 shows the high-side operation where NIN pin must be kept low and the OE pin controls the switch. Figure 5 shows the low-side operation where NIN pin must be kept high and the OE pin controls the switch. Figure 6 shows the push-pull operation where OE pin must be kept high and the NIN pin controls the switch. If the OUT signal differs from what declared in tables 4, 5 and 6 (due to external forcing) for more than 14 μ s (cf. Electrical Characteristics No. 510), this event will be signalled by a low level at MON output. In case of a short circuit at OUT and resulting temperature shut-down, logic level of MON will be undefined.

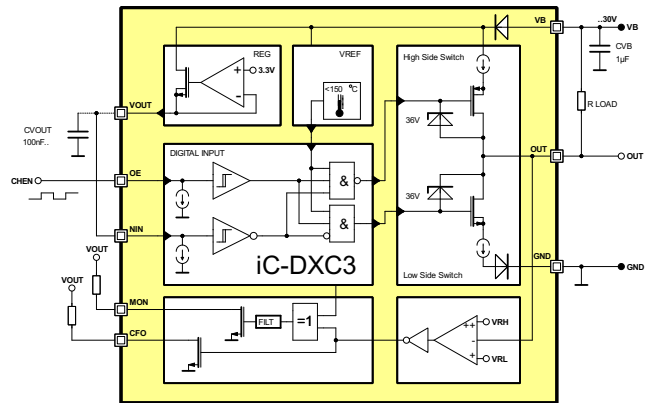

Figure 5: Configuration as Low-Side (NPN-Switch)

Output Table. Low-side mode (NPN-Switch)				
OE	NIN	OUT	CFO	Mode
L	H	Z (H)	L	Low-Side, passive pull up
H	H	L	H	Low-Side, active pull down

Table 5: Output Function table Fig. 5. Low-side mode (NPN-Switch) with external pull-up.

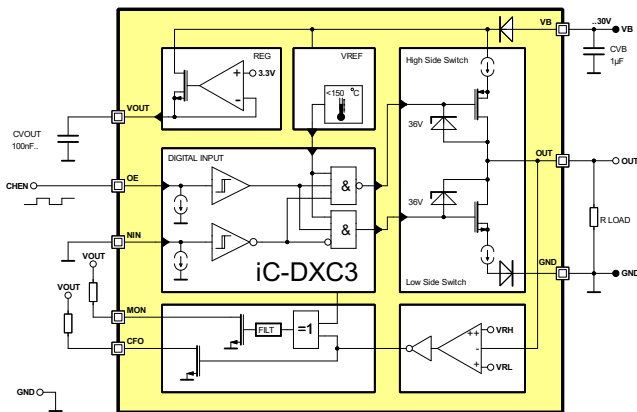

Figure 4: Configuration as High-Side (PNP-Switch)

Output Table. High-side mode (PNP-Switch)				
OE	NIN	OUT	CFO	Mode
L	L	Z (L)	H	High-Side, passive pull down
H	L	H	L	High-Side, active pull up

Table 4: Output Function table Fig. 4. High-side mode (PNP-Switch) with external pull-down.

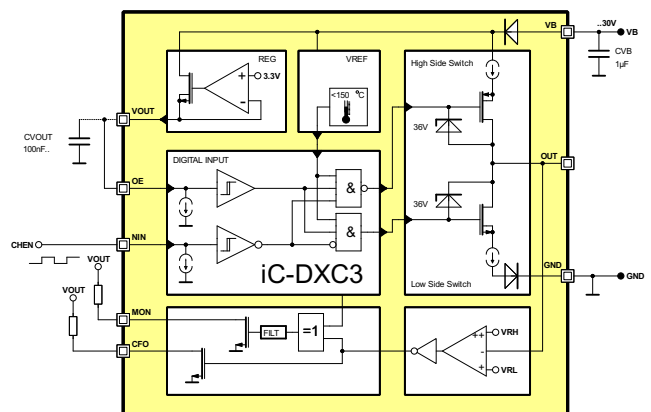

Figure 6: Configuration as Pushpull

Output Table. Push-Pull mode				
OE	NIN	OUT	CFO	Mode
H	H	L	H	Push-Pull, active pull down
H	L	H	L	Push-Pull, active pull up

Table 6: Output Function table Fig. 6. Push-Pull mode

CIRCUIT PROTECTION

The iC-DXC3 is reverse polarity protected via internal circuitry. As far as the maximum voltage ratings are not exceeded, no possible supply combination at the line side pins (VB, GND and OUT) can damage the chip.

Since the chip current consumption is relatively low, discharging of the backup capacitor C1 can be very

slow, and injected charge through disturbances may in general result in capacitor voltage exceeding maximum ratings, leading to malfunction or destruction of circuitry and associated parts. Thus EMC requirements will afford more external circuitry. Figure 7 shows the iC-DXC3 with the additional protective device D1, D2 and D3.

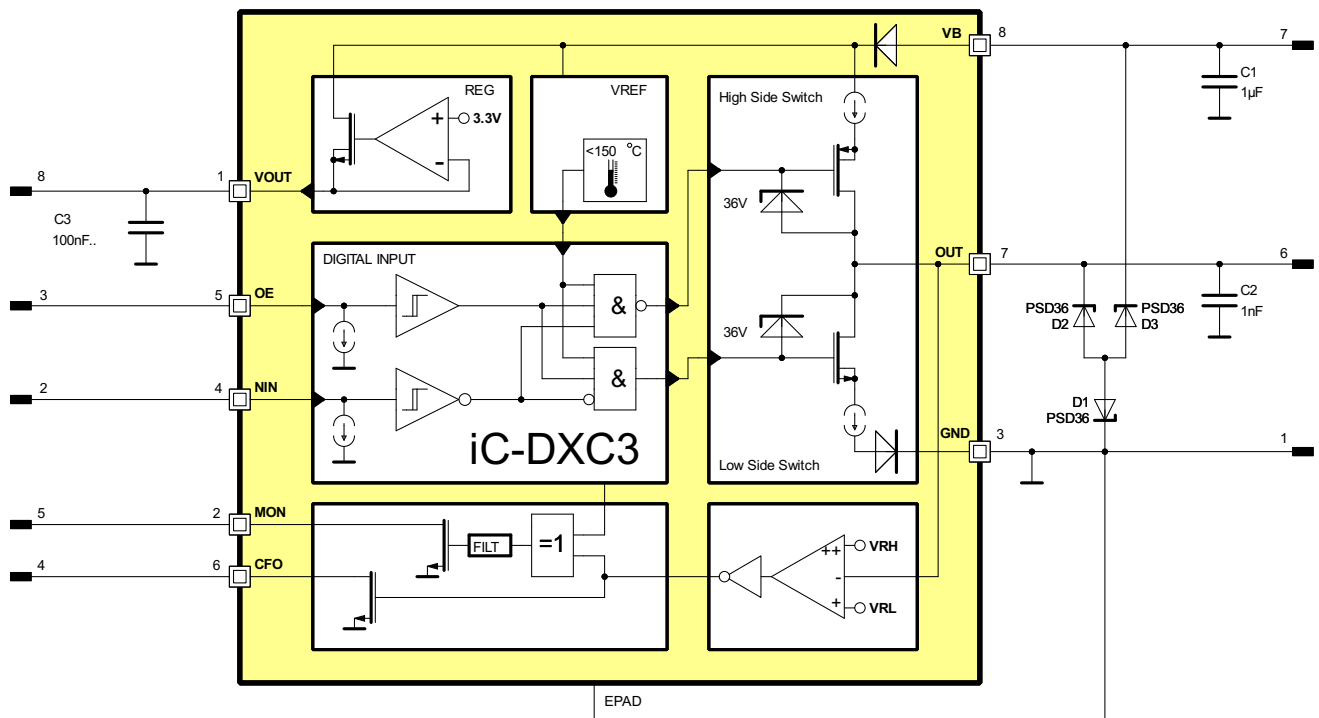

Figure 7: Circuit schematic showing protective devices

For over-voltage protection, the suppressor diodes D1, D2 and D3 absorb transients on supply line injected externally on the cable. Clamp voltage of the diodes should be rated slightly above maximum specified supply voltage.

These currents can be passed to ground or to VB by the internal ESD diodes of the iC-DXC3. Whereas negative current injection will simply be drained off to ground, positive current injection will charge capacitor C1 further to higher voltages. If not suppressor diodes nor any other over-voltage protection is implemented,

the backup capacitor C1 should be kept small. A typical 100nF value is normally OK.

Suggested protective devices

At $V_{B_{max}}$ of 36V, suppressor diodes with a breakdown voltage from 36V has to be chosen in order to minimize the energy in iC-DXC3 for higher Voltages. For example Diode type like Vishay GSOT36C or PJS36V from Panjit should be enough as protection.

TIMING DESCRIPTION

The iC-DXC3 has a built-in spurious pulse suppression that prevents short (undesired) pulses at the input pins from reaching the output. Every pulse at OE or NIN pins shorter than $1.6 \mu\text{s}$ (cf. Electrical Characteristics No. 306) will be ignored and the output will not react. The minimum required pulse length to be sure that the output reacts is $4 \mu\text{s}$ (cf. Electrical Characteristics No. 307). That means that every pulse longer than $4 \mu\text{s}$ will be propagated to the output but with an additional propagation delay of $1.2 \mu\text{s}$ maximum. The resulting maximum propagation delay is $5.2 \mu\text{s}$ (cf. Electrical Characteristics No. 305).

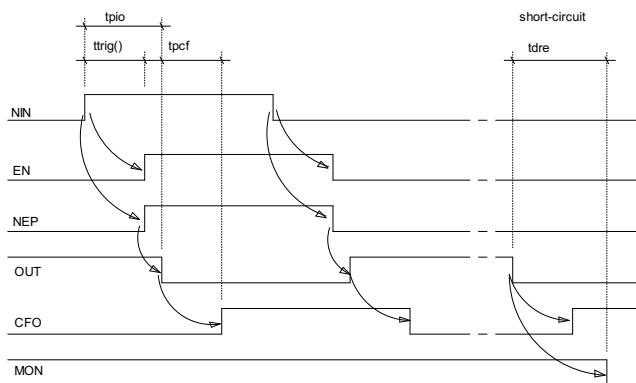

Figure 8: Timing diagram in push-pull operation mode with OE high

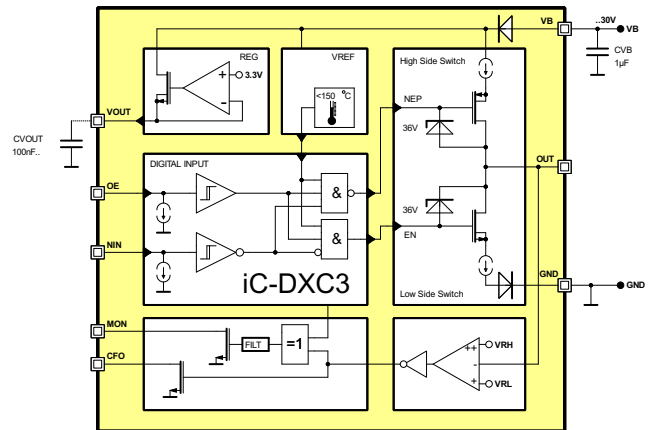

Figure 9: Block diagram with EN and NEP internal signals

iC-Haus expressly reserves the right to change its products and/or specifications. An info letter gives details as to any amendments and additions made to the relevant current specifications on our internet website www.ichaus.de/infoletter; this letter is generated automatically and shall be sent to registered users by email.

Copying – even as an excerpt – is only permitted with iC-Haus' approval in writing and precise reference to source.

iC-Haus does not warrant the accuracy, completeness or timeliness of the specification and does not assume liability for any errors or omissions in these materials.

The data specified is intended solely for the purpose of product description. No representations or warranties, either express or implied, of merchantability, fitness for a particular purpose or of any other nature are made hereunder with respect to information/specification or the products to which information refers and no guarantee with respect to compliance to the intended use is given. In particular, this also applies to the stated possible applications or areas of applications of the product.

iC-Haus conveys no patent, copyright, mask work right or other trade mark right to this product. iC-Haus assumes no liability for any patent and/or other trade mark rights of a third party resulting from processing or handling of the product and/or any other use of the product.

iC-DXC3

DIGITAL SENSOR I/O DRIVER



Rev A1, Page 12/12

ORDERING INFORMATION

Type	Package	Order Designation
iC-DXC3	DFN8 3x3 mm	iC-DXC3 DFN8 3x3

For technical support, information about prices and terms of delivery please contact:

iC-Haus GmbH
Am Kuemmerling 18
D-55294 Bodenheim
GERMANY

Tel.: +49 (61 35) 92 92-0
Fax: +49 (61 35) 92 92-192
Web: <http://www.ichaus.com>
E-Mail: sales@ichaus.com

Appointed local distributors: http://www.ichaus.com/sales_partners