

FEATURES

- ◆ 6 current-limited and short-circuit-proof push-pull driver stages in complementary configuration
- ◆ Guaranteed driver current can be set to 30mA or 100mA
- ◆ Outputs compatible to TTL at low load current
- ◆ Integrated free-wheeling diodes
- ◆ Short switching times and high slew rate
- ◆ Schmitt trigger inputs with integrated pull-up current sources and clamping diodes
- ◆ Inputs compatible to TTL and CMOS levels
- ◆ Operating points can be shifted by separate feed of inputs
- ◆ On-chip thermal shutdown with hysteresis
- ◆ Extended temperature range of -25..85 °C

APPLICATIONS

- ◆ Line driver for 24V control engineering

PACKAGES

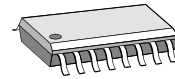

SO16W

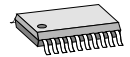

TSSOP20
thermal pad

BLOCK DIAGRAM

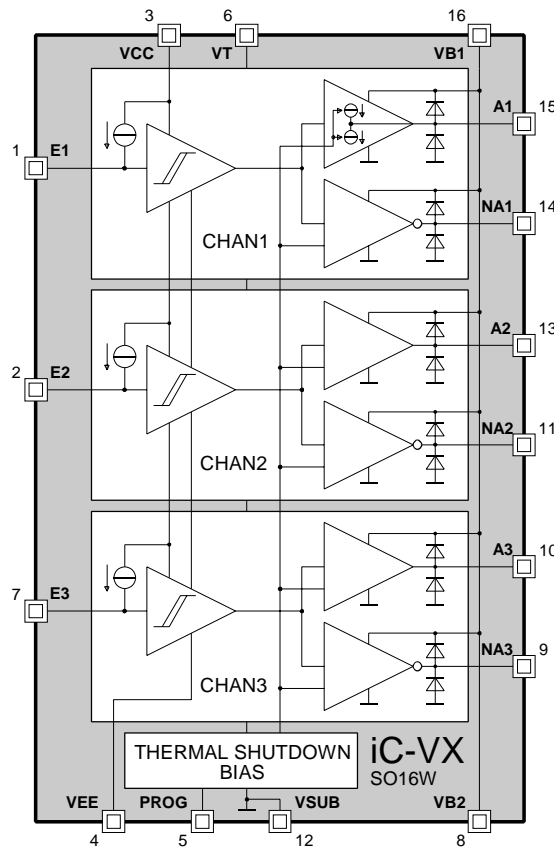

DESCRIPTION

The device iC-VX is a monolithic, 3-channel line driver with complementary outputs for 24V applications.

The Schmitt trigger inputs contain pull-up current sources and run on separate operating voltages. Their reference potential can be adjusted in the range of the output stage supply voltage to adapt the input threshold voltage for various applications.

The guaranteed driver current can be set to 30mA (PROG pin open) or 100mA (PROG pin at VSUB). At low load the drivers are TTL-compatible due to reduced saturation voltages. The output stages are current-limited and, due to the shutdown at overtemperature, they are also protected against thermal destruction. Due to the hysteresis of the overtemperature shutdown, the driver outputs switch on and off as a function of the iC power loss until the overload ceases.

For 30mA driver current the short-circuit strength is guaranteed directly by the iC. For 100mA driver current in 24V applications this is guaranteed by 30Ω series resistors.

Free-wheeling diodes at the outputs protect the iC against echoes of mismatched lines. The inputs and outputs of the channels have diodes for protection against destruction by ESD.

PACKAGES SO16W, TSSOP20 to JEDEC Standard

PIN CONFIGURATION SO16W

(top view)

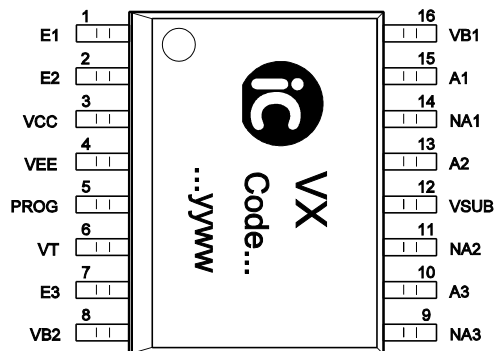

PIN FUNCTIONS

Name Function

E1	Input Channel 1
E2	Input Channel 2
VCC	Inputs Supply Voltage (+5V)
VEE	Reference Voltage for Inputs (0V)
PROG	Programming Input for Driver Current (open 30mA, PROG to VSUB 100mA)
VT	+4.5..+30V Bias Supply Voltage
E3	Input Channel 3
VB2	+4.5..+30V Drivers Supply Voltage
NA3	Inverting Output Channel 3
A3	Output Channel 3
NA2	Inverting Output Channel 2
VSUB	Ground, Substrate
A2	Output Channel 2
NA1	Inverting Output Channel 1
A1	Output Channel 1
VB1	+4.5..+30V Drivers Supply Voltage

PIN CONFIGURATION TSSOP20tp 4.4mm

(top view)

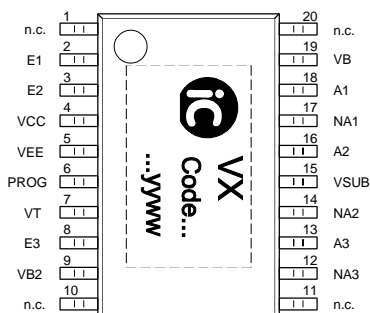

Pins VB1 and VB2 must both be connected when the 100mA driver current is set.

To enhance heat removal, the TSSOP20 package offers a large area pad to be soldered (a connection is only permitted to VSUB).

ABSOLUTE MAXIMUM RATINGS

Values beyond which damage may occur; device operation is not guaranteed.

Item	Symbol	Parameter	Conditions	Fig.			Unit
					Min.	Max.	
G001	VCC-VEE	Supply Voltage for Schmitt Trigger Inputs			0	12	V
G002	VB1, VB2	Positive Supply Voltage for Output Drivers			0	32	V
G003	VT	Bias Supply Voltage			0	30	V
G004	V(PROG)	Voltage at PROG			0	2	V
G005	I(A,NA)	Output Current in A1..3, NA1..3			-300	300	mA
G006	I(E)	Current in E1..3			-8	8	mA
E001	Vd()	ESD Susceptibility, all Inputs and Outputs	MIL-STD-883, Method 3015, HBM 100pF discharged through 1.5kΩ			1	kV
TG1	Tj	Junction Temperature			-40	155	°C
TG2	Ts	Storage Temperature			-40	150	°C

THERMAL DATA

Operating Conditions: VB= 4.5..30V, VT= VCC= 5V ±10%

Item	Symbol	Parameter	Conditions	Fig.				Unit
					Min.	Typ.	Max.	
T1	Ta	Operating Ambient Temperature Range (extended range to -40°C on request)			-25		85	°C
T2	Rthja	SO16W Thermal Resistance Junction to Ambient	surface mounted with ca. 2cm ² heat sink at leads (see Demo Board)			55	75	K/W
T3	Rthja	TSSOP20 Thermal Resistance Junction to Ambient	surface mounted, thermal pad soldered to ca. 2cm ² heat sink			30	40	K/W

All voltages are referenced to ground unless otherwise noted.

All currents into the device pins are positive; all currents out of the device pins are negative.

ELECTRICAL CHARACTERISTICS

Operating Conditions:

 $V_{EE} = V_{SUB} = 0V$, $V_B = 4.5..30V$, $V_T = V_{CC} = 5V \pm 10\%$, $T_j = -25..125^\circ C$, unless otherwise noted

Item	Symbol	Parameter	Conditions	Tj °C	Fig.				Unit
						Min.	Typ.	Max.	
Total Device									
001	VCC-VEE	Permissible Supply Voltage Range for Inputs				4.5		11	V
002	VCC	Permis. Supply Voltage VCC				4.5		V _B	V
003	VEE	Permis. Supply Voltage VEE				0		V _B -4.5V	V
004	I(VCC)	Supply Current in VCC		27 125		0.5	1.35 0.89	2.4	mA mA mA
005	V _T	Permis. Bias Supply Voltage V _T				4.5		V _B	V
006	I(V _T)	Supply Current in V _T	PROG at V _{SUB}	27 125		3	6.4 5.1	12	mA mA mA
007	I(V _T)	Supply Current in V _T	PROG open	27 125		1.3	2.6 2.2	5	mA mA mA
008	V _{B1} , V _{B2}	Permis. Drivers Supply Voltage at V _{B1} and V _{B2}				4.5		30	V
009	I(V _B)	Supply Current in V _B	PROG at V _{SUB} , I(A1..3, NA1..3)= 0	27 125		0.6	2.1 1.5	4.8	mA mA mA
010	I(V _B)	Supply Current in V _B	PROG open, I(A1..3, NA1..3)= 0	27 125		0.15	0.42 0.31	1.2	mA mA mA
Driver Outputs A1..3, NA1..3									
101	V _{s()} hi	Saturation Voltage hi (driver capability 100mA)	PROG to V _{SUB} , V _{B1} and V _{B2} connected, V _{s(A)hi} = V _B -V(A,NA); I(A,NA)= -10mA I(A,NA)= -30mA I(A,NA)= -100mA					1.0 1.2 2.0	V V V
102	V _{s()} lo	Saturation Voltage lo (driver capability 100mA)	PROG to V _{SUB} , V _{B1} and V _{B2} connected; I(A,NA)= 10mA I(A,NA)= 30mA I(A,NA)= 100mA					0.9 1.0 1.5	V V V
103	I _{sc()} hi	Short-Circuit Current hi (driver capability 100mA)	PROG to V _{SUB} , V _{B1} and V _{B2} connected, V(A,NA)= 0V			-350		-100	mA
104	I _{sc()} lo	Short-Circuit Current lo (driver capability 100mA)	PROG to V _{SUB} , V _{B1} and V _{B2} connected, V(A,NA)= V _B			100		350	mA
105	S _{R()}	Slew-Rate hi-lo (driver capability 100mA)	PROG to V _{SUB} , V _{B1} and V _{B2} connected, R _L (A,NA)= 750Ω, C _L (A,NA)= 100pF			100			V/μs

ELECTRICAL CHARACTERISTICS

Operating Conditions:

 $V_{EE} = V_{SUB} = 0V$, $V_B = 4.5..30V$, $V_T = V_{CC} = 5V \pm 10\%$, $T_j = -25..125^\circ C$, unless otherwise noted

Item	Symbol	Parameter	Conditions	Tj °C	Fig.				Unit
						Min.	Typ.	Max.	
Driver Outputs A1..3, NA1..3 (continued)									
106	Vs()hi	Saturation Voltage hi (driver capability 30mA)	PROG open, Vs()hi= VB-V(A,NA); I(A,NA)= -3mA I(A,NA)= -10mA I(A,NA)= -30mA					0.9 1.0 1.4	V V V
107	Vs()lo	Saturation Voltage lo (driver capability 30mA)	PROG open; I(A,NA)= 3mA I(A,NA)= 10mA I(A,NA)= 25mA, VB= 4.5..10V I(A,NA)= 30mA, VB= 10..30V					0.9 1.0 1.2 1.2	V V V V
108	Isc()hi	Short-Circuit Current hi (driver capability 30mA)	PROG open, V(A,NA)= 0V			-100		-30	mA
109	Isc()lo	Short-Circuit Current lo (driver capability 30mA)	PROG open, V(A,NA)= VB			30		100	mA
110	SR()i	Slew-Rate hi-lo (driver capability 30mA)	PROG open, RL(A/NA)= 750Ω, CL(A/NA)= 100pF			30			V/μs
111	Vs()lo	Saturation Voltage lo for TTL-Levels	I(A,NA)= 1.6mA					0.4	V
112	IO(A,NA)	Tri-state Leakage Current	Tj> Toff, V(A,NA)= 0..VB			-100		100	μA
113	Vc()hi	Clamp Voltage hi	Vc(A,NA)hi= V(A)-VB; I(A,NA)= 100mA			0.4		1.7	V
114	Vc()lo	Clamp Voltage lo	I(A,NA)= -100mA			-1.7		-0.4	V
Inputs E1..3									
201	Vt(E)hi	Threshold Voltage hi referred to VCC-VEE						45	%
202	Vt(E)lo	Threshold Voltage lo referred to VCC-VEE				35			%
203	Vt(E)hys	Hysteresis				3		6	%
204	I(E)	Input Current	V(E)= VEE..VCC-1V			-81	-55	-30	μA
205	Vc(E)hi	Clamp Voltage hi	Vc(E)hi= V(E)-VCC; I(E)= 4mA			0.4		1.6	V
206	Vc(E)lo	Clamp Voltage lo	I(E)= -4mA			-1.6		-0.4	V
207	tp()	Propagation Delay E-A, E-NA (driver capability 100mA)	50%V(E) : 50%I(A,NA); PROG to VSUB, RL(A/NA)= 750Ω				0.4	1	μs
208	Δtp (A-NA)	Delay Skew A vs. NA (driver capability 100mA)	Δtp()= tp(E-A) -tp(E-NA); PROG to VSUB, RL(A/NA)= 750Ω				0.15	0.5	μs
209	tp()	Propagation Delay E-A, E-NA (driver capability 30mA)	50%V(E) : 50%I(A,NA); PROG open, RL(A/NA)= 750Ω				0.8	2	μs
210	Δtp (A-NA)	Delay Skew A vs. NA (driver capability 30mA)	Δtp()= tp(E-A) -tp(E-NA); PROG open, RL(A/NA)= 750Ω				0.35	1	μs
Thermal Shutdown, Bias									
301	Toff	Thermal Shutdown Threshold				125	135	155	°C
303	Thys	Thermal Shutdown Hysteresis				15	22	30	°C

APPLICATIONS INFORMATION

Line drivers for control engineering couple digital signals with TTL or CMOS levels via lines to 24V systems. Due to possible line short circuits, the drivers are current-limited and shut down in the event of overtemperature.

The device iC-VX permits the operating points of the Schmitt trigger inputs to be shifted with the supply voltages VCC and VEE, thus within the range of the output stage supply voltage VB.

The programming of the driver current to 30mA or 100mA permits optimum matching on the basis of line length and required transmission rate. External series resistors must be provided for higher driver current to ensure short-circuit strength in 24V applications. Furthermore, these series resistors improve the ability of the driver to adapt to the line surge impedance.

EXAMPLE 1: Short lines

Short lines of 5m, for example, are approximations of capacitive load for the iC; no adjustment of characteristic impedance is required. With each switching slope changeover losses of $P_c = 1/2 V_B \times I(A)$ per channel occur in the iC. The load capacity is reloaded with the guaranteed driver current $I(A) \geq 30mA$. These changeover losses determine the possible cut-off frequency, since the high chip power loss without cooling results in shutdown of the iC. At high capacitive load the transmission rate can also be limited by the fall and rise times which reduce the signal strength.

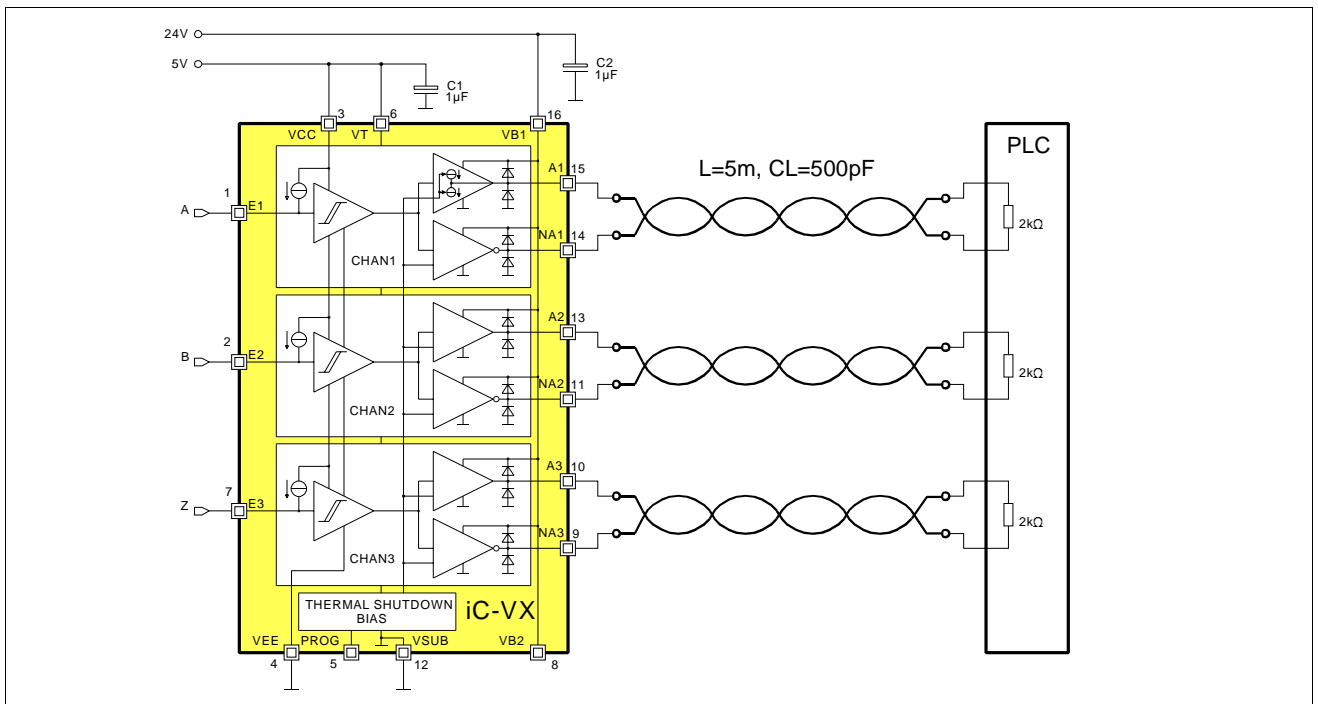

Fig. 1: Balanced data transmission at low capacitive load, PROG pin open: $I(A) \geq 30mA$

As a typical application, Fig. 1 shows the transmission of the output signals of an incremental rotary encoder (track A, track B, index pulse Z) to a programmable control (PLC). The maximum signal frequency which is limited by the power loss can be estimated by standardizing the limiting values of the example for short lines:

$$f_{\max} \approx 200kHz \times \frac{500pF}{CL} \times \left(\frac{24V}{VB} \right)^2 \times \frac{413K - T_a}{70K} \times \frac{75K/W}{R_{thja}} \times \frac{2}{\text{channels}} \quad (1.1)$$

If the slew-rate is the limiting factor, the following applies for the maximum signal frequency (saturation voltages neglected):

$$f_{\max} \approx \frac{30mA}{4 \times VB \times (CL + 1nF)} \quad (1.2)$$

CL = Capacitive load at output A to output NA

VB = Supply voltage

T_a = Ambient temperature

R_{thja} = Thermal resistance chip/board/ambient ($R_{thja} = R_{thjb} + R_{thba}$)

EXAMPLE 2: Long lines

Lines which are relatively long, for example 100m, require a higher driver current and an adapter. An appropriate 30Ω series resistor at the driver output ensures short-circuit strength and a suitable division of the power loss to resistor and iC. The PROG pin at VSUB selects the high driver current of 100mA. In this case the driver supply must be channeled via VB1 and VB2.

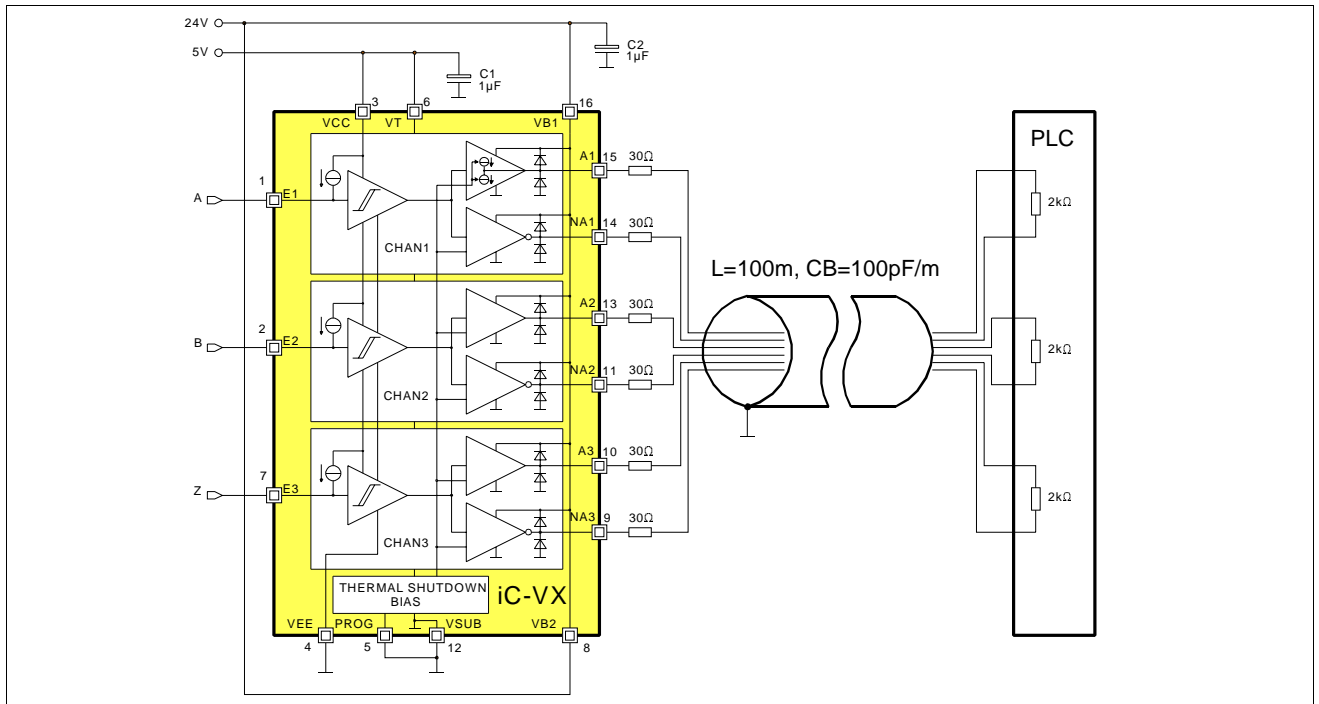

Fig. 2: Balanced data transmission at high capacitive load, PROG to VSUB: $I(A) \geq 100\text{mA}$

The maximum signal frequency which is restricted by the power loss can be estimated by standardizing to the limiting values of the example for long lines:

$$f_{\max} \approx 20\text{kHz} \times \frac{100\text{pF/m}}{CB} \times \frac{100\text{m}}{L} \times \left(\frac{24\text{V}}{VB} \right)^2 \times \frac{413\text{K} - T_a}{70\text{K}} \times \frac{75\text{K/W}}{R_{thja}} \times \frac{2}{\text{channels}} \quad (2.1)$$

If the slew rate is the limiting factor, the following applies for the maximum signal frequency (saturation voltages neglected):

$$f_{\max} \approx \frac{100\text{mA}}{4 \times VB \times (C_L + 1\text{nF})} \quad (2.2)$$

CB = Line capacitance per meter

L = Length of the line

C_L = Effective capacitance at output A to NA

VB = Supply voltage

T_a = Ambient temperature

R_{thja} = Thermal resistance chip/board/ambient ($R_{thja} = R_{thjb} + R_{thba}$)

The current limitation of the driver stages extends to about 300mA in the 100mA setting. By that, until the activation of the thermal shutdown, the maximum power dissipation for each 30Ω series resistance and for the iC at 24V can be estimated.

Max. power loss in the resistor:

$$P_{\max R} = I^2 \times R = (300\text{mA})^2 \times 30\Omega = 2.7\text{W}$$

Max. power loss in the iC pro channel:

$$P_{\max iC} = (VB - I(A) \times R) \times I(A) = 4.5\text{W}$$

The average power loss in the iC and the resistors declines when the thermal shutdown interrupts the driver outputs due to abnormal rising chip temperature. The installed series resistances should suit for the estimated power dissipation to avoid overload due to permanent line short-circuits. If the drivers are operated at low power supply, e.g. $V_B = 12V$ instead of $V_B = 24V$, the power loss account for the iC declines and the thermal shutdown is initially delayed or is not activated at all. If V_B is under 20V, lower resistors are permitted ($>10\Omega$) without endangering the short-circuit strength of the iC. Consequently, the iC's temperature monitoring is reactivated and even 1/3W resistors are not overloaded.

EXAMPLE 3: Data transmission in the case of activation with TTL/CMOS signals

In the case of activation with TTL/CMOS logic, the device can be operated with the 5V logic supply to VCC and VT. The pins VEE and VSUB must be connected to the logic ground. The 24V supply voltage must be applied to VB1 or VB2 (Fig. 3).

Figure 4 shows an alternative application with common positive supplies for logic and driver. Ground, respectively the reference potential VEE for the inputs, is generated by using a negative voltage regulator. This wiring increases the iC power dissipation due to the higher bias supply voltage at VT.

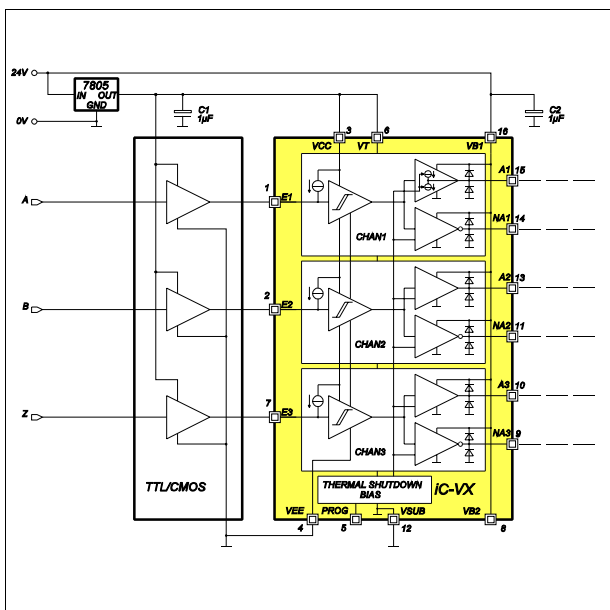

Fig. 3: $V_{EE} = V_{SUB}$

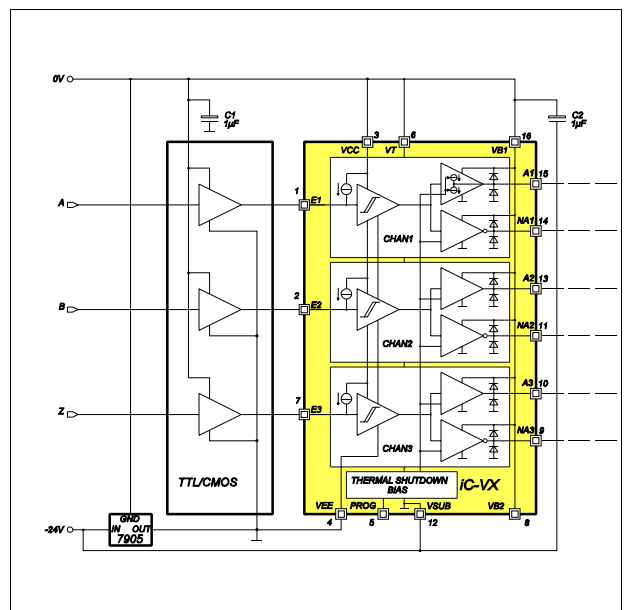

Fig. 4: $V_{EE} > V_{SUB}$

In both examples the operating points of the Schmitt trigger inputs E1..3 are compatible with TTL and CMOS levels.

Depending on the line length, the driver current may be selected to 30mA with PROG= open or to 100mA with PROG= VSUB. In case of the 100mA driver current the final stages must be supplied via VB1 and VB2.

DEMO BOARD

The device iC-VX with SO16W package is equipped with a Demo Board for test purposes. The following figures show the wiring as well as the top and bottom layout of the test PCB.

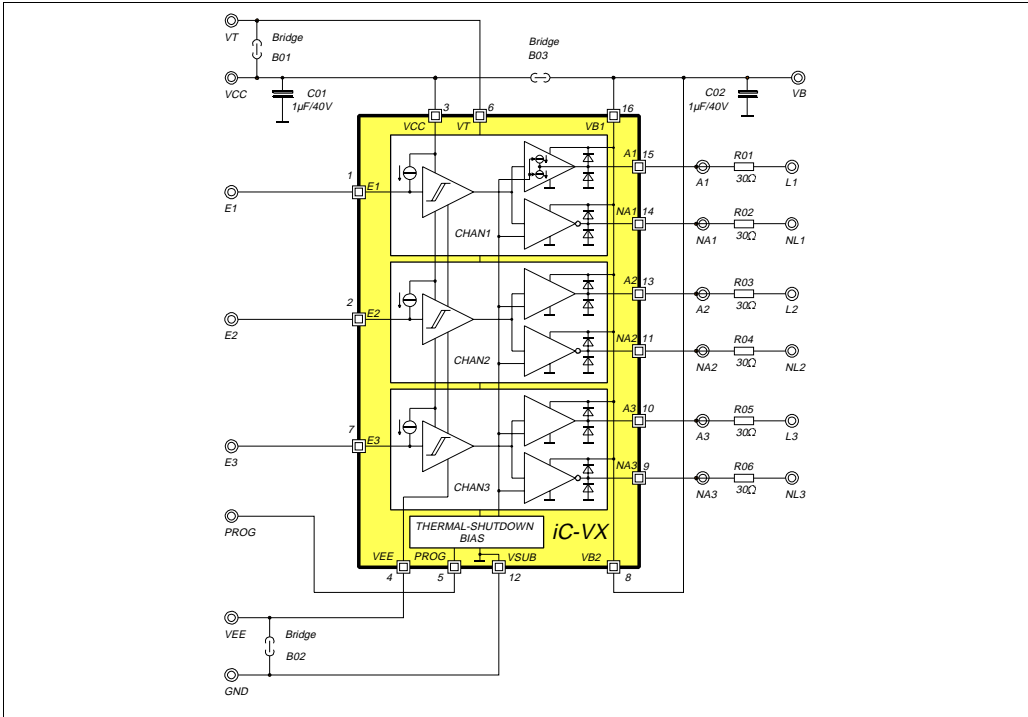

Fig. 6: Schematic diagram of the Demo Board

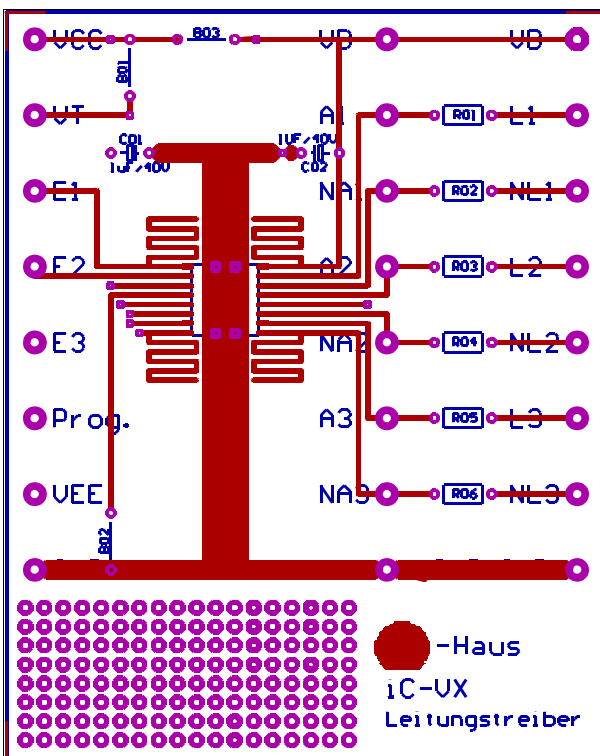

Fig. 7: Demo Board (components side)

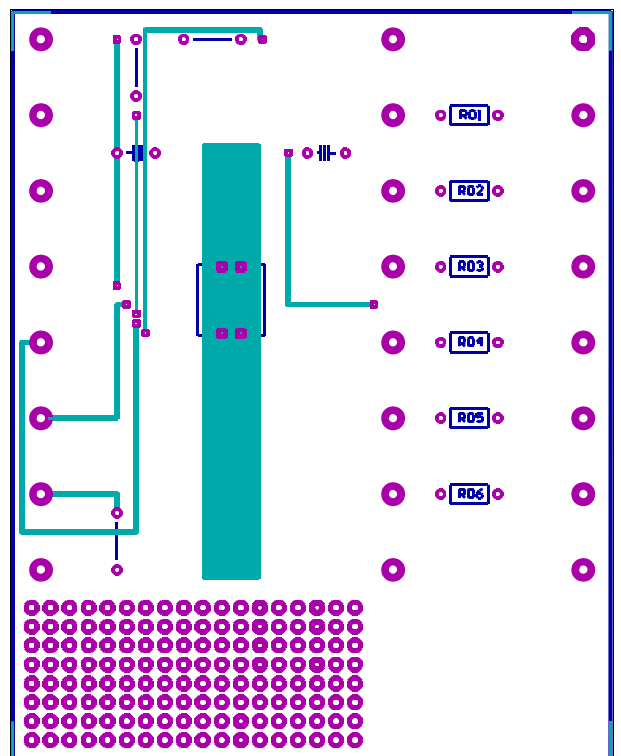

Fig. 8: Demo Board (solder dip side)

ORDERING INFORMATION

Type	Package	Order designation
iC-VX	SO16W TSSOP20tp 4.4mm	iC-VX SO16W iC-VX TSSOP20
VX Demo Board		VX DEMO

For information about prices, terms of delivery, options for other case types, etc., please contact:

iC-Haus GmbH
Am Kuemmerling 18
D-55294 Bodenheim
GERMANY

Tel +49-6135-9292-0
Fax +49-6135-9292-192
<http://www.ichaus.com>

This specification is for a newly developed product. iC-Haus therefore reserves the right to modify data without further notice. Please contact us to ascertain the current data. The data specified is intended solely for the purpose of product description and is not to be deemed guaranteed in a legal sense. Any claims for damage against us - regardless of the legal basis - are excluded unless we are guilty of premeditation or gross negligence.

We do not assume any guarantee that the specified circuits or procedures are free of copyrights of third parties.

Copying - even as an excerpt - is only permitted with the approval of the publisher and precise reference to source.