

# iC-GE100

## PWM RELAY/SOLENOID DRIVER

### FEATURES

- ◆ Current control for inductive actuators at 24 V (10 to 36 V)
- ◆ Power saving and power dissipation reduced switching
- ◆ Individual setting of energising and hold current
- ◆ Contact conserving switching of relays synchronous to the mains
- ◆ High efficient current control up to 100 mA
- ◆ Monitoring of coil current, supply voltage and temperature
- ◆ Shutdown with overtemperature and undervoltage
- ◆ Status indication via LED or logic output
- ◆ Fast demagnetising with 15 V countervoltage

### APPLICATIONS

- ◆ PWM drive for inductive loads (e.g. 6/12 V relays, electrovalves) from 24 V
- ◆ Relay low-/high-side switch

### PACKAGES

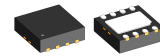

DFN8 3x3

### BLOCK DIAGRAM

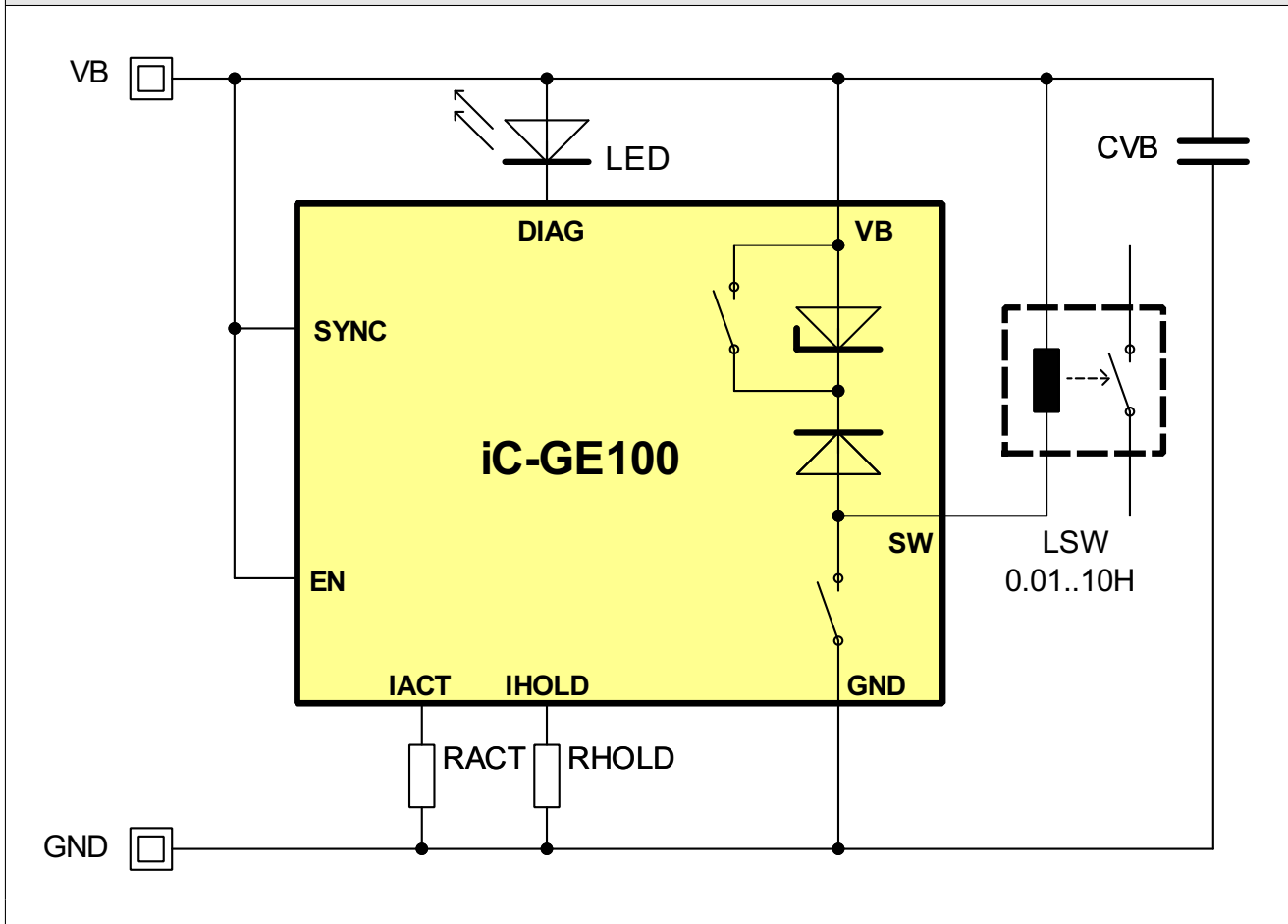

# iC-GE100

## PWM RELAY/SOLENOID DRIVER

### DESCRIPTION

iC-GE100 is a PWM driver for inductive loads, such as relay coils, solenoid valves and other inductive loads.

The setpoints for the coil's energising and hold current are pre-set by means of external resistors RACT and RHOLD. These currents can be set in a range from 10 to 100 mA. The iC-GE100 switches from energising to hold mode after 50 ms provided that the set energising current has been reached.

The changeover between energising and hold modes is suitable for typical relay drives which require a powerful initial energising current which can then be reduced after closing the air gap in a magnetic circuit. The quadratic dependence on the current intensity means that cutting the current by half reduces the power dissipation by ca. 75%.

Using PWM the output current is controlled to the values set at RACT and RHOLD. The internal fly-back diode maintains the current during the switch-

ing pauses. The switching frequency of ca. 80 kHz is provided by the internal oscillator.

The device is shutdown by a Low signal at input EN or the removal of the power supply; the current reduction in the coil is supported by the changeover of the free-wheeling circuit. The Zener diode now active permits higher free-wheeling voltages and thus a quicker demagnetising of the coil.

The status indicator LED is constantly ON when hold mode is functioning correctly and flashes with low voltage, excessive temperature or when the coil current in energise mode has not reached the setpoint. The driver output is shutdown with low voltage or excessive temperature. Alternatively to using an LED output DIAG signals the correct operating by outputting a high signal.

The input signal at EN can be synchronised with the zero crossing at input SYNC. Thus by using an external R/C network, the switching of the coil can be synchronised with the load current of e.g. the relay.

### PACKAGES SO8, PDIP8 to JEDEC

#### PIN CONFIGURATION DFN8 3 mm x 3 mm

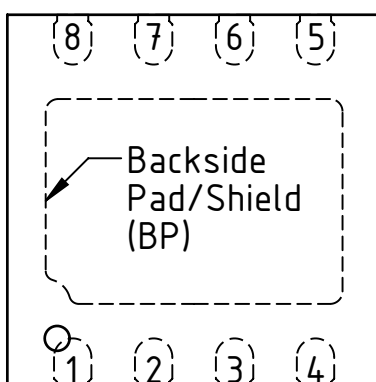

#### PIN FUNCTIONS

No.	Name	Function
1	GND	Ground
2	SW	PWM Output
3	VB	+10...36 V Supply Voltage
4	IHOLD	Hold Current Setup
5	IACT	Energising Current Setup
6	DIAG	Status Output
7	SYNC	Sync Input
8	EN	Enable Input

The *Thermal Pad* is to be connected to a Ground Plane (GND) on the PCB.

**Only pin 1 marking on top or bottom defines the package orientation (Ⓢ GE100 label and coding is subject to change).**

# iC-GE100

PWM RELAY/SOLENOID DRIVER

preliminary



Rev A0.3, Page 3/11

## PACKAGE DIMENSIONS

### RECOMMENDED PCB-FOOTPRINT

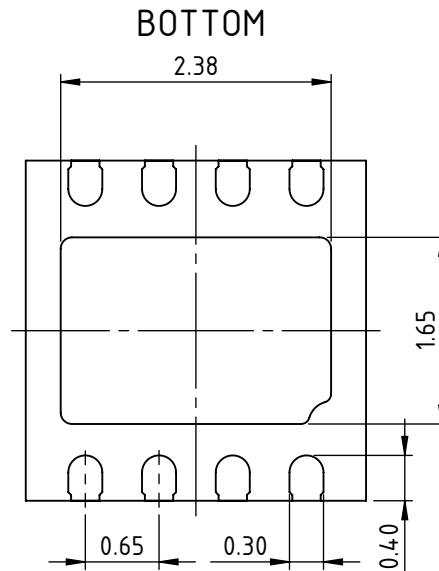
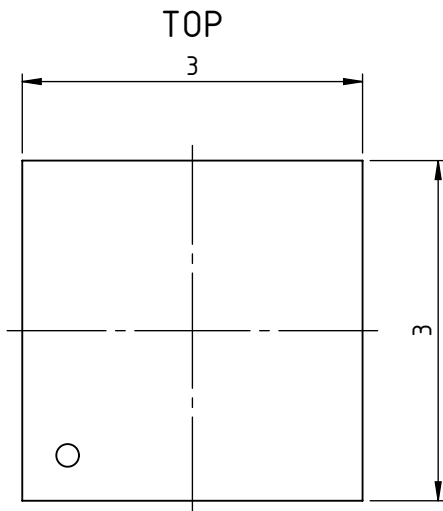
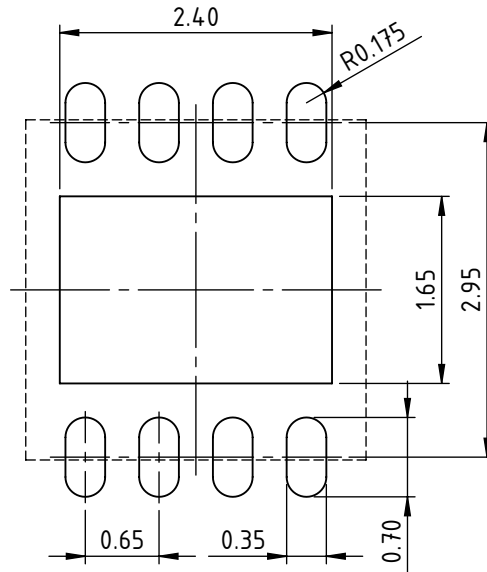
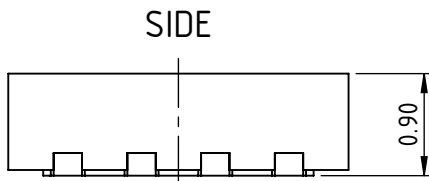

dra\_dfn8-1\_pack\_1, 15:1

# iC-GE100

## PWM RELAY/SOLENOID DRIVER

preliminary



Rev A0.3, Page 4/11

### ABSOLUTE MAXIMUM RATINGS

Beyond these values damage may occur; device operation is not guaranteed.

Item No.	Symbol	Parameter	Conditions			Unit
				Min.	Max.	
G001	V(VB)	Voltage at VB		-0.3	37	V
G002	I(VB)	Current in VB		-100	6	mA
G003	V(SW)	Voltage at OUT		-0.3	53	V
G004	I(SW)	Output Current in OUT		-6	100	mA
G005	V(DIAG)	Voltage at LED		-0.3	37	V
G006	I(DIAG)	Current in LED		-6	8	mA
G007	V(IACT)	Voltage at ISET		-0.3	7	V
G008	I(IACT)	Current in ISET		-6	6	mA
G009	V(IHOLD)	Voltage at IHOLD		-0.3	7	V
G010	I(IHOLD)	Current in IHOLD		-6	6	mA
G011	V(EN)	Voltage at IN		-0.3	37	V
G012	I(EN)	Current in IN		-6	6	mA
G013	V(SYNC)	Voltage at SYNC		-6	37	V
G014	I(SYNC)	Current in SYNC		-6	6	mA
G015	VD()	Susceptibility to ESD at all pins	HBM 100 pF discharged through 1.5 k $\Omega$		2	kV
G016	T <sub>j</sub>	Junction Temperature		-40	150	°C
G017	T <sub>s</sub>	Storage Temperature		-40	150	°C

### THERMAL DATA

Operating Conditions: VB = 10...36 V, LSW = 0.01...10 H, RACT = 6.2 k...62 k $\Omega$ , RHOLD = 6.2 k...62 k $\Omega$

Item No.	Symbol	Parameter	Conditions				Unit
				Min.	Typ.	Max.	
T01	T <sub>a</sub>	Operating Ambient Temperature Range		-40		85	°C
T02	R <sub>thja</sub>	Thermal Resistance Chip/Ambient	surface mounted, thermal pad soldered to ca. 2 cm <sup>2</sup> heat sink		30	40	K/W

All voltages are referenced to ground unless otherwise stated.

All currents flowing into the device pins are positive; all currents flowing out of the device pins are negative.

# iC-GE100

## PWM RELAY/SOLENOID DRIVER



Rev A0.3, Page 5/11

### ELECTRICAL CHARACTERISTICS

Operating Conditions:  $V_B = 10...36\text{ V}$ ,  $LSW = 0.01...10\text{ H}$ ,  $RACT = 6.2\text{ k}\dots62\text{ k}\Omega$ ,  $RHOLD = 6.2\text{ k}\dots62\text{ k}\Omega$ ,  $T_j = -40...125\text{ }^\circ\text{C}$ .

Item No.	Symbol	Parameter	Conditions				Unit
				Min.	Typ.	Max.	
<b>Total Device</b>							
001	$V_B$	Permissible Supply Voltage Range		10		36	V
002	$I(V_B)$	Supply Current in $V_B$	$EN < 0.8\text{ V}$			20	$\mu\text{A}$
003	$I(V_B)$	Supply Current in $V_B$	$EN = \text{hi}$	0.5		4	mA
004	$V_c(\text{lo})$	Clamp Voltage lo at all Pins	$I() = -4\text{ mA}$ , other Pins open	-1.4		-0.3	V
005	$V_c(\text{lo})$	Clamp Voltage lo SYNC	$I() = -4\text{ mA}$ , other pins open	-6		-0.3	V
006	$V_c(\text{hi})$	Clamp Voltage hi at $V_B$ , EN, DIAG, SYNC	$I() = 4\text{ mA}$ , other Pins open	37			V
007	$V_c(\text{hi})$	Clamp Voltage hi at IACT, IHOLD	$I() = 4\text{ mA}$ , other pins open	7			V
008	$V_c(\text{hi})$	Clamp Voltage hi at IACT, IHOLD	$I() = 4\text{ mA}$ , other pins open	7			V
009	$V_c(\text{hi})$	Clamp Voltage hi at SW	$I(\text{SW}) = 4\text{ mA}$ , referenced to $V_B$ , other pins open	10		17	V
<b>Driver Output OUT</b>							
101	$V_s(\text{lo})$	Saturation Voltage lo	$I(\text{SW}) = 100\text{ mA}$ (cf. Fig. 1)			600	mV
102	$V_s(\text{lo})$	Saturation Voltage lo	$I(\text{SW}) = 10\text{ mA}$ (cf. Fig. 1)			100	mV
103	$I(\text{SW})$	PWM-Current Range		10		100	mA
104	$I_{sc}()$	Short-circuit Current	$V(\text{SW}) = V_B$	100		tbd	mA
105	$V_c(\text{hi})$	Clamp Voltage hi at PWM-Free-Wheeling	$V_c(\text{hi}) = V(\text{SW}) - V_B$ ; $EN = \text{hi}$ , $I(\text{SW}) = 100\text{ mA}$ (cf. Fig. 1)			600	mV
106	$V_c(\text{hi})$	Clamp Voltage hi at PWM-Free-Wheeling	$V_c(\text{hi}) = V(\text{SW}) - V_B$ ; $EN = \text{hi}$ , $I(\text{SW}) = 10\text{ mA}$ (cf. Fig. 1)			100	mV
107	$V_c(\text{off})$	Clamp Voltage hi at Turn-off	$V_c(\text{hi}) = V(\text{SW}) - V_B$ ; $EN: \text{hi} \rightarrow \text{lo}$ , $I(\text{SW}) = 100\text{ mA}$ (cf. Fig. 1)	12	15	17	V
108	$I_{IK}()$	Leakage Current	$I_N = \text{lo}$ , $V(\text{SW}) = 0...V_B$		1	10	$\mu\text{A}$
109	$t_{\text{won}}(\text{min})$	Minimum PWM Turn-on Duration	$EN = \text{hi}$ , $I(\text{SW}) > I(\text{SW})_{\text{act}}$ resp. $I(\text{SW})_{\text{hold}}$ (cf. Figure 1)	250		1000	ns
<b>Input IN</b>							
201	$V_t(\text{on})$	Threshold Voltage hi		1.1		1.4	V
202	$V_t(\text{off})$	Threshold Voltage lo		0.8		1.1	V
203	$V_t(\text{hys})$	Hysteresis	$V_t(\text{hys}) = V_t(\text{on}) - V_t(\text{off})$	200		400	mV
204	$I_{pd}()$	Pull-down Current	$V(EN) = 0.8...36\text{ V}$			20	$\mu\text{A}$
205	$t_p(V_B\text{-SW})$	Turn-on Delay after power-up	$EN = V_B$ , $V_B = V_{\text{Boff}} \rightarrow V_{\text{Bon}}$			40	$\mu\text{s}$
206	$t_p(EN\text{-SW})$	Turn-on Delay	$EN: \text{lo} \rightarrow \text{hi}$ until SW active	30			$\mu\text{s}$
207	$t_p(EN\text{-SW})$	Turn-off Delay	$EN: \text{hi} \rightarrow \text{lo}$ until SW inactive	10			$\mu\text{s}$
208	$t_p(EN\text{-DIAG})$	Delay Time from EN to DIAG = hi or LED permanently on	no error	20			$\mu\text{s}$
<b>Status Monitor DIAG</b>							
401	$I_{pd}()$	Pull-down Current	$V(\text{DIAG}) = 6\text{ V}\dots V_B$ , SW active, no error	3	5	8	mA
402	$V_{B\text{lo}}$	Permissible Supply Voltage for LED operation at DIAG		6		36	V
403	$V()_{\text{hi}}$	Hi-Level at DIAG	without LED	5		6.5	V
404	$f()$	Frequency on Error		1.8	2.4	3.6	Hz
405	$V_s(\text{lo})$	Saturation Voltage lo	$I(\text{DIAG}) = 200\text{ }\mu\text{A}$ , without LED			0.4	V
406	$I_{pu}()$	Pull-up Current	$V(\text{DIAG}) = 0...4\text{ V}$	-120	-100	-80	$\mu\text{A}$
407	$V_{\text{Bon}}$	Turn-on Threshold at $V_B$	$V(\text{DIAG}): \text{lo} \rightarrow \text{hi}$	8	8.5	9	V
408	$V_{\text{Boff}}$	Undervoltage Threshold at $V_B$	Decreasing voltage $V_B$ , $V(\text{DIAG}): \text{hi} \rightarrow \text{lo}$	7.5	8	8.5	V
409	$V_{\text{Bhys}}$	Hysteresis	$V_{\text{Bhys}} = V_{\text{Bon}} - V_{\text{Boff}}$	200	500	800	mV
410	$T_{\text{off}}$	Thermal Shutdown Temperature		140		170	$^\circ\text{C}$
411	$T_{\text{on}}$	Thermal Release Temperature	Decreasing temperature	120		150	$^\circ\text{C}$
412	$T_{\text{hys}}$	Thermal Shutdown Hysteresis	$T_{\text{hys}} = T_{\text{off}} - T_{\text{on}}$	10	20	30	$^\circ\text{C}$

# iC-GE100

## PWM RELAY/SOLENOID DRIVER

preliminary



Rev A0.3, Page 6/11

### ELECTRICAL CHARACTERISTICS

Operating Conditions:  $V_B = 10 \dots 36 \text{ V}$ ,  $L_{SW} = 0.01 \dots 10 \text{ H}$ ,  $R_{ACT} = 6.2 \text{ k} \dots 62 \text{ k} \Omega$ ,  $R_{HOLD} = 6.2 \text{ k} \dots 62 \text{ k} \Omega$ ,  $T_j = -40 \dots 125 \text{ }^\circ\text{C}$ .

Item No.	Symbol	Parameter	Conditions				Unit
				Min.	Typ.	Max.	
<b>Reference IACT and IHOLD</b>							
701	V()	Reference Voltage IACT and IHOLD		1.14	1.20	1.26	V
702	Isc()	Short-Circuit Current	$V(IHOLD) = 0 \text{ V}$ or $V(IACT) = 0 \text{ V}$	-2.5	-1.8	-0.3	mA
703	K1	Transfer Value for Energising Current $R_{ACT} = K1 / I(SW)_{act}$	$I(SW)_{act} = 10 \dots 100 \text{ mA}$	560	620	680	A $\Omega$
704	K2	Transfer Value for Hold Current $R_{HOLD} = K2 / I(SW)_{hold}$	$I(SW)_{hold} = 10 \dots 100 \text{ mA}$	560	620	680	A $\Omega$
<b>Oscillator</b>							
J01	fosc	Mean Oscillator Frequency	$(f_{max} + f_{min}) / 2$	60	80	120	kHz
J02	df	Frequency Variation	$(f_{max} - f_{min}) / (2 * f_{osc})$	12		15	%
<b>Synchronisation SYNC</b>							
S01	Vth()sync	Trigger Threshold at SYNC		-20		20	mV
S02	Iik()	Leakage Current	$V(SYNC) = -3 \text{ V} \dots 3 \text{ V}$	-10		10	nA

**ELECTRICAL CHARACTERISTICS: Diagrams**

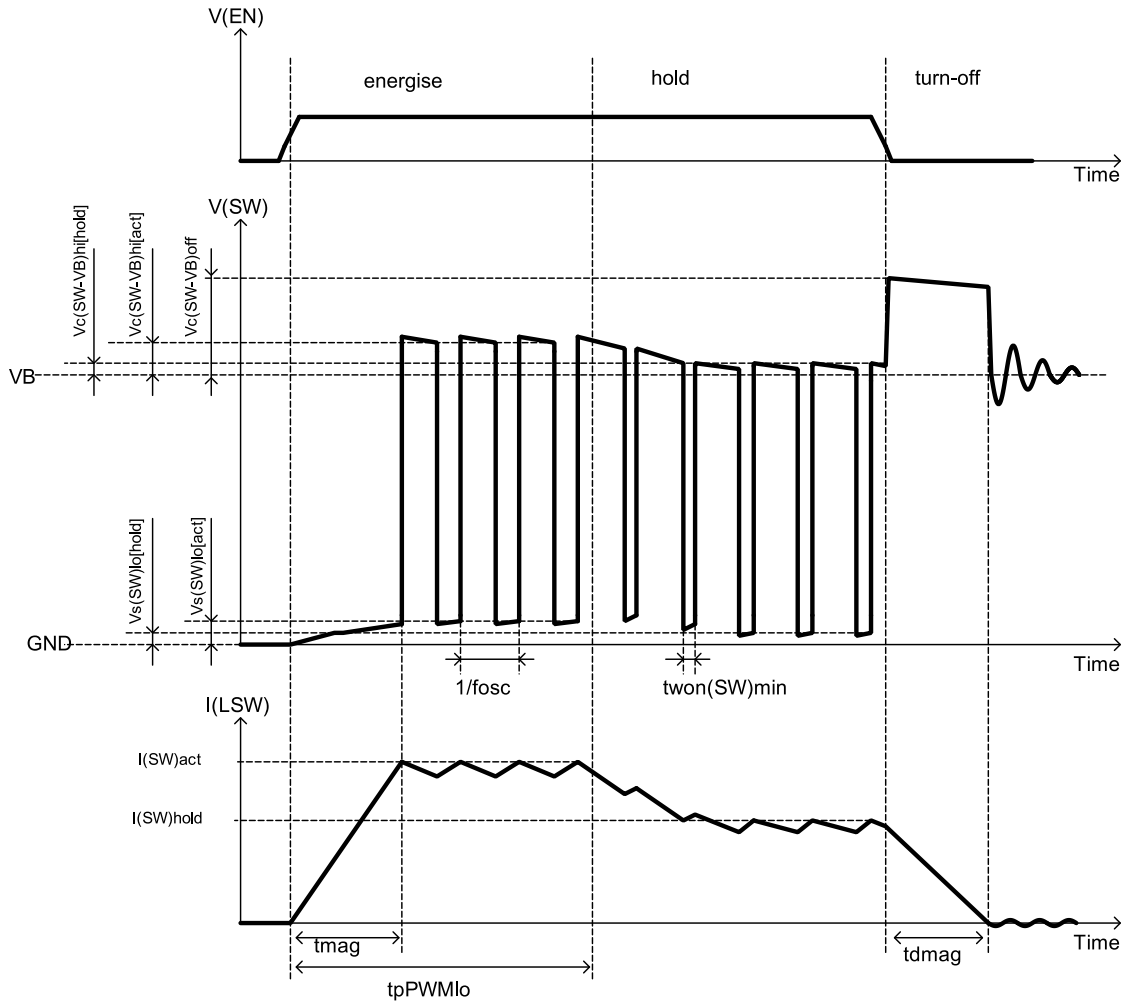

Figure 1: Operation modes: energise mode, hold mode and turn-off

$$t_{mag} \approx \frac{I(SW)_{act} \times LSW}{VB} \quad (1)$$

$$t_{dmag} \approx \frac{I(SW)_{hold} \times LSW}{V_c(SW - VB)_{off}} \quad (2)$$

### APPLICATIONS INFORMATION

#### Setting the coil current

The following equations can be given for the energise and hold modes of the PWM control using Electrical Characteristics Nos. 703 resp. 704:

$$RACT = \frac{K1}{I(SW)_{act}} \quad (3)$$

$$RHOLD = \frac{K2}{I(SW)_{hold}} \quad (4)$$

#### Example

For a relay with a starting current of 70 mA and 40 mA hold current the following applies:

$$RACT = \frac{620 \Omega A}{0.07 A} = 8.8 k\Omega \quad (5)$$

$$RHOLD = \frac{620 \Omega A}{0.04 A} = 15.5 k\Omega \quad (6)$$

#### Application circuits

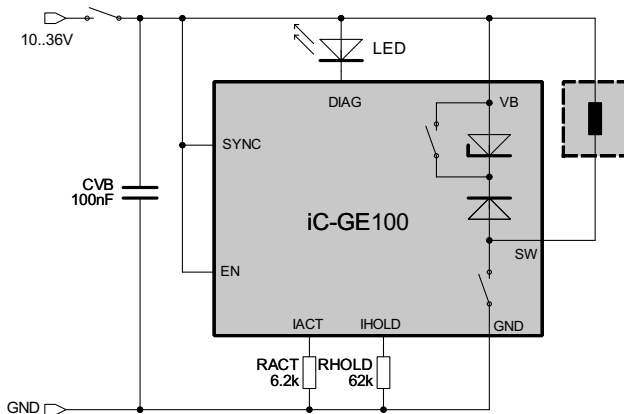

Figure 2: Activation by switching VB

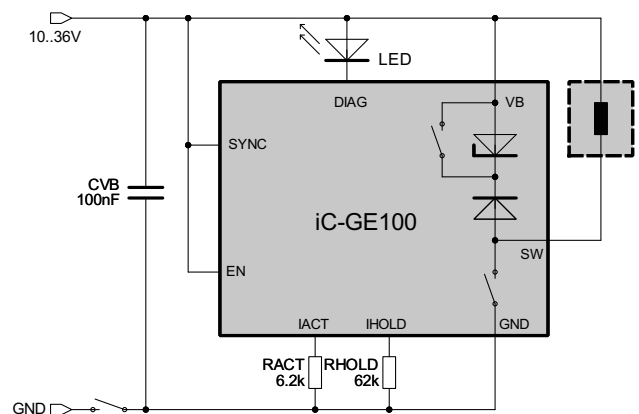

Figure 3: Activation by switching GND

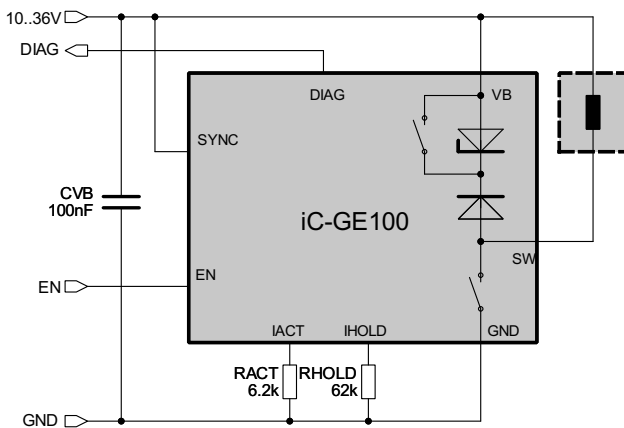

Figure 4: Activation via EN  
feedback from DIAG with 5 V logic levels

# iC-GE100

## PWM RELAY/SOLENOID DRIVER

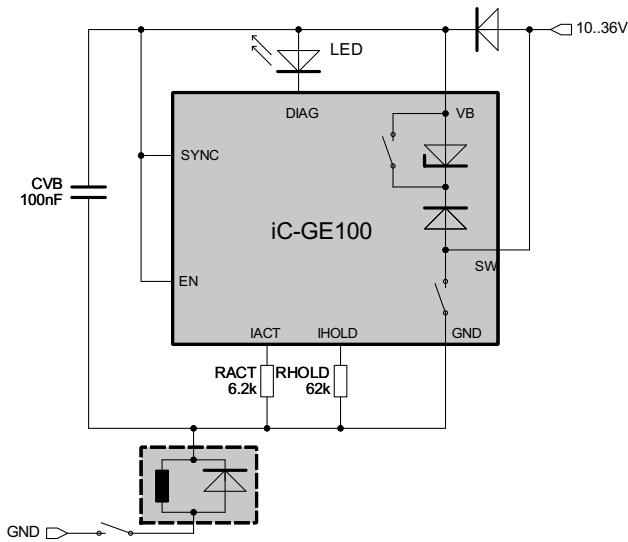

Figure 5: High-side driver for relays with free-wheeling diode

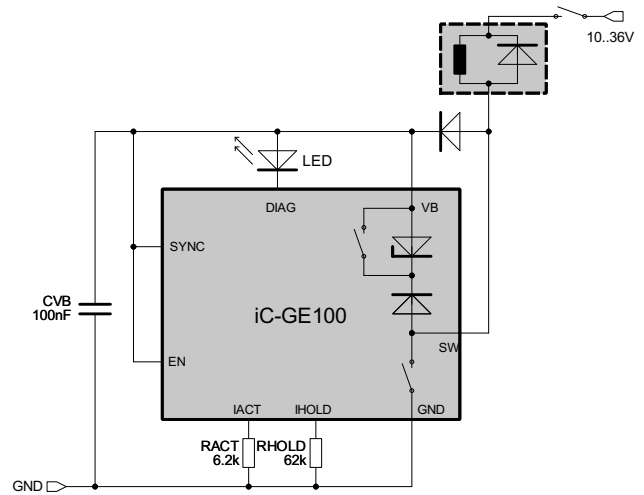

Figure 6: Low-side driver for relays with free-wheeling diode

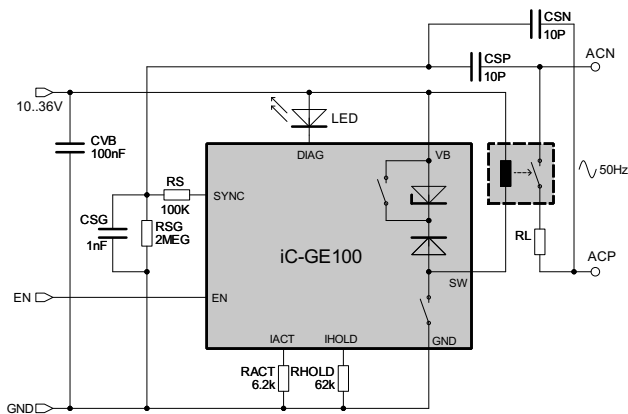

Figure 7: Utilising the SYNC input

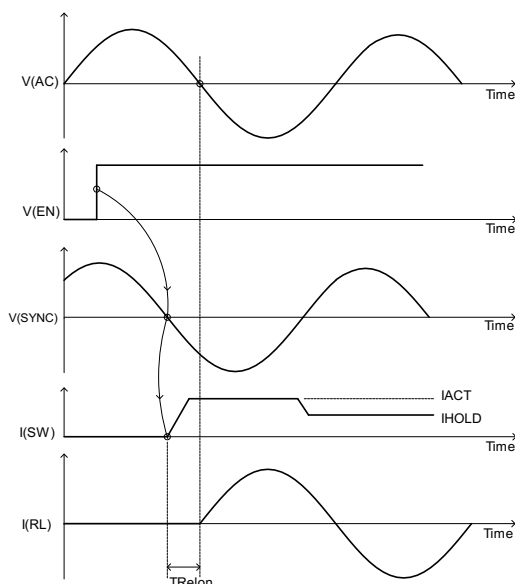

Figure 8: Utilising the SYNC input

By means of resistors  $RS^*$  and capacitors  $CS^*$  a phase shifted signal at SYNC is derived from the 50 Hz load supply.

Thus the relay is activated resp. deactivated with zero crossing of the load supply after working EN.

The phase shift is used to compensate the switching delay of the relay so that the load can be switched at zero current.

The benefit from synchronous switching may be utilised, if the switching times are short and reproducible.

# iC-GE100

## PWM RELAY/SOLENOID DRIVER



Rev A0.3, Page 10/11

iC-Haus expressly reserves the right to change its products and/or specifications. An info letter gives details as to any amendments and additions made to the relevant current specifications on our internet website [www.ichaus.de/infoletter](http://www.ichaus.de/infoletter); this letter is generated automatically and shall be sent to registered users by email.

Copying – even as an excerpt – is only permitted with iC-Haus' approval in writing and precise reference to source.

iC-Haus does not warrant the accuracy, completeness or timeliness of the specification and does not assume liability for any errors or omissions in these materials.

The data specified is intended solely for the purpose of product description. No representations or warranties, either express or implied, of merchantability, fitness for a particular purpose or of any other nature are made hereunder with respect to information/specification or the products to which information refers and no guarantee with respect to compliance to the intended use is given. In particular, this also applies to the stated possible applications or areas of applications of the product.

iC-Haus conveys no patent, copyright, mask work right or other trade mark right to this product. iC-Haus assumes no liability for any patent and/or other trade mark rights of a third party resulting from processing or handling of the product and/or any other use of the product.

As a general rule our developments, IPs, principle circuitry and range of Integrated Circuits are suitable and specifically designed for appropriate use in technical applications, such as in devices, systems and any kind of technical equipment, in so far as they do not infringe existing patent rights. In principle the range of use is limitless in a technical sense and refers to the products listed in the inventory of goods compiled for the 2008 and following export trade statistics issued annually by the Bureau of Statistics in Wiesbaden, for example, or to any product in the product catalogue published for the 2007 and following exhibitions in Hanover (Hannover-Messe).

We understand suitable application of our published designs to be state-of-the-art technology which can no longer be classed as inventive under the stipulations of patent law. Our explicit application notes are to be treated only as mere examples of the many possible and extremely advantageous uses our products can be put to.

# iC-GE100

PWM RELAY/SOLENOID DRIVER



Rev A0.3, Page 11/11

## ORDERING INFORMATION

Type	Package	Order Designation
iC-GE100	DFN8 3 mm x 3 mm	iC-GE100 DFN8-3x3

For technical support, information about prices and terms of delivery please contact:

**iC-Haus GmbH**  
Am Kuemmerling 18  
D-55294 Bodenheim  
GERMANY

**Tel.: +49 (61 35) 92 92-0**  
**Fax: +49 (61 35) 92 92-192**  
**Web: <http://www.ichaus.com>**  
**E-Mail: [sales@ichaus.com](mailto:sales@ichaus.com)**

**Appointed local distributors: [http://www.ichaus.com/sales\\_partners](http://www.ichaus.com/sales_partners)**