

Product Description

The IP00C732 is a single-chip solution for high-resolution displays such as 4K2K or 2560x1600. It can also be configured to drive a single 1080P or WUXGA output with 4 input images tiled together on a single output.

The IP00C732 has 4 input channels at 166 Mpixels/sec. each, in either RGB, YUV4:2:2 or YUV4:4:4 formats. It features 4 independent scaler blocks, with full 10-bit internal processing. The IP00C732 has a powerful output overlay block that is fully programmable to suit different types of applications. The overlay block can be programmed to superimpose all 4 inputs in any combination with alpha blending or color key blending. When used on a single high-resolution display, the IP00C732 has a state-of-the-art image overlap feature to produce a seamless image without any artifacts.

The IP00C732 is an ideal solution to replace an FPGA which would require a significant amount of external memory and glue logic. The advantages of the IP00C732 are reduced board space, ease of programming, and cost.

Applications

Typical applications for the IP00C732 are:

- Video-Wall: Take any number of input images, up to 4, and scale them to fit within a single output, with programmable blending and positioning.
- 4K2K/2560x1600 Display: Convert any input image seamlessly to a high-resolution output, without the need for external glue logic.



Actual Size

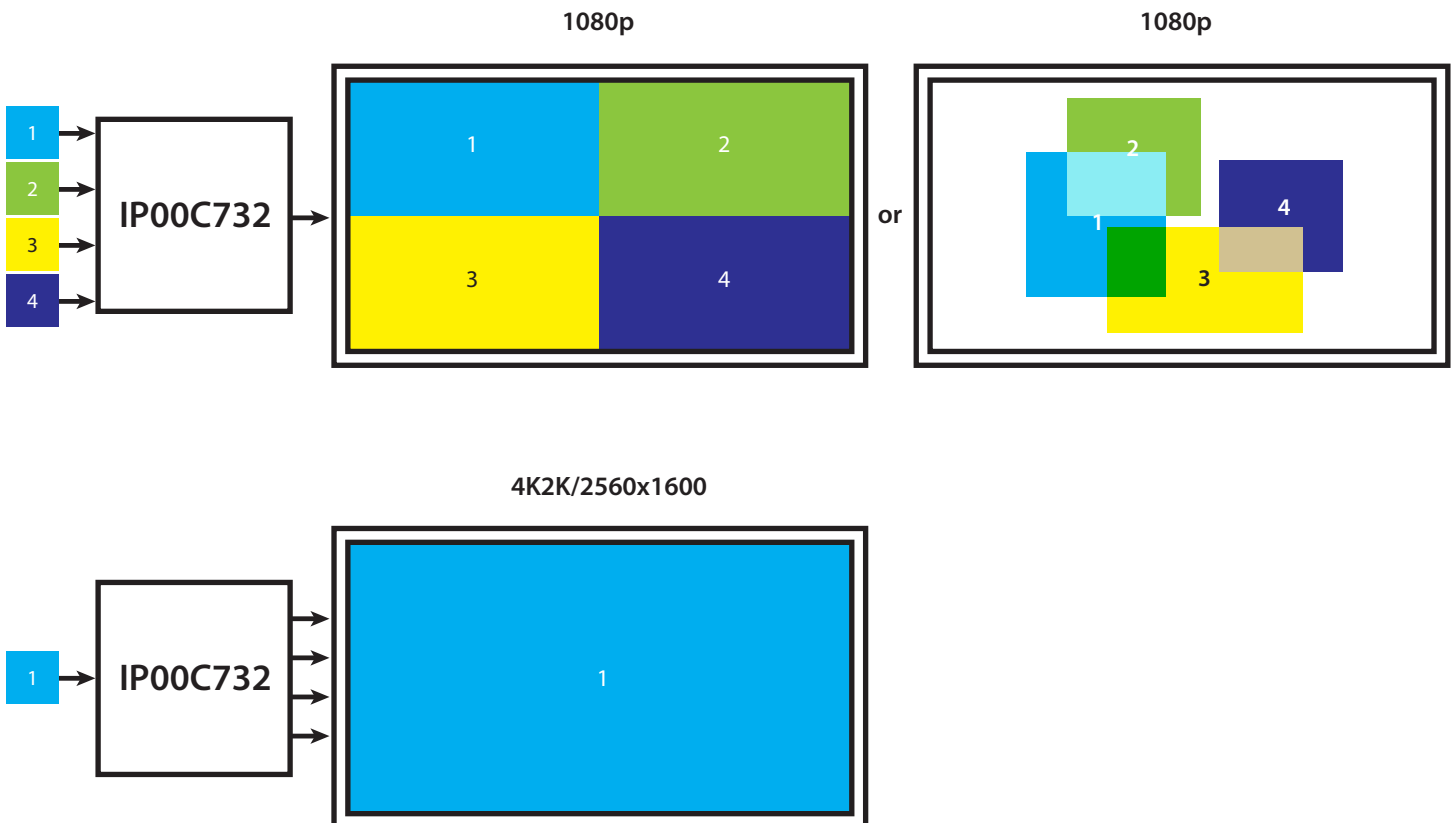

IP00C732 FEATURES

INPUT

- 30-bit RGB/30-bit YUV 4:4:4/20-bit YUV 4:2:2 @ 166 MHz
- Up to 16384 pixels/line with 2176 pixels of active video

OUTPUT

- 30-bit RGB/30-bit YUV 4:4:4/20-bit YUV 4:2:2 @ 166 MHz
- Up to 16384 pixels/line with 2176 pixels of active video

SCALING

- 6 symbol filter with FIR Filter
- Independent H and V scaling ratios (aspect ratio correction)
- Coefficient filter ROM embedded (64 set)
- Frame rate conversion with frame tear protection

BITMAP OSD

- 256 colors
- Font data development function (65536 characters)
- Support for blinking and semi-transparent (4 color) OSD
- Independent 4 channel output for OSD
- Bitmap transferable from serial flash

CPU INTERFACE

- 8-bit parallel, 4-line serial, I2C

IMAGE QUALITY CONTROL

- 4 channel overlay
- 3x3 color conversion matrix, bias onboard
- Color Key-blending
- Alpha-blending

EXTERNAL MEMORY

- Memory-bus 64-bit
- DDR2-SDRAM PC667 (512Mbit x 16) x 4

POWER SUPPLY

- 3.3V, 1.8V and 1.2V

PACKAGE

- 544-pin Plastic BGA; (1mm pitch), 27mm x 27mm

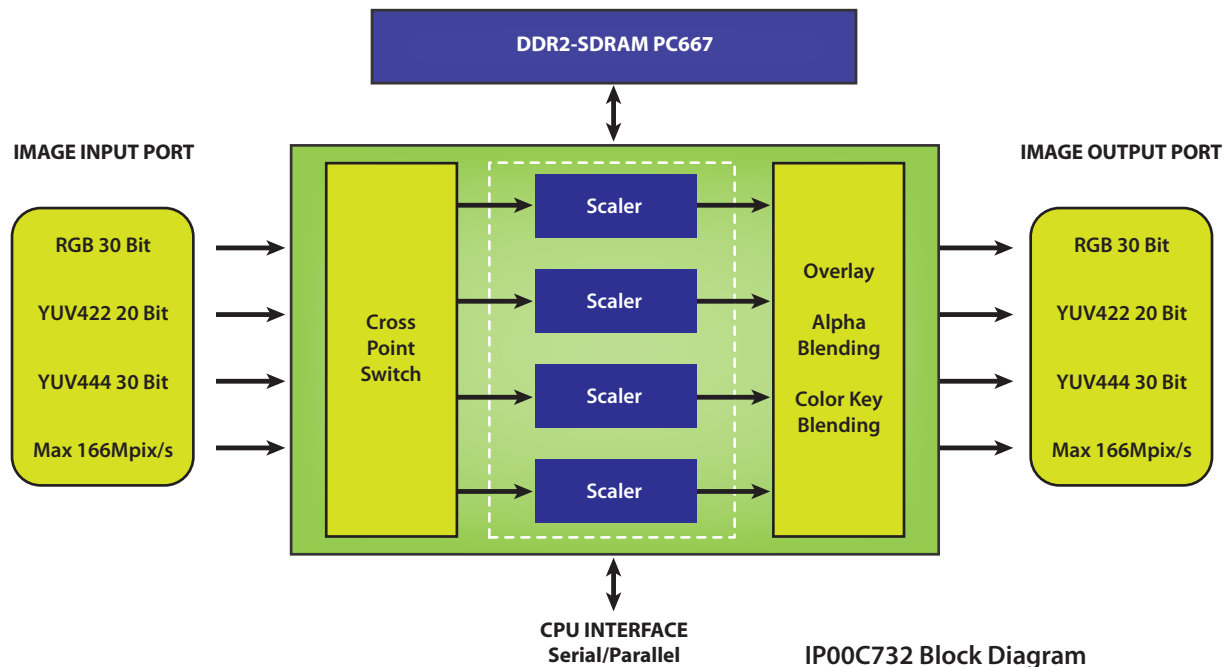

For more information please visit www.i-chips.com

i-Chips

IMAGE PROCESSORS

i-Chips USA • 780 Montague Expy, Suite 308 • San Jose, CA 95131 • Tel: 408 577-1432 • Fax: 408 577-1560