



DESCRIPTION

The ESS ES7120 HDMI Transmitter was designed to connect ESS' DVD Decoder ICs to HDTV TVs. The ES7120 transports high-definition Digital Video and multi-channel Digital Audio over a TMDS interface to high-definition TV displays. The ES7120 contains a Link and PHY and complies with the HDMI 1.1 (High Definition Multimedia Interface) and HDCP 1.1 (High-Bandwidth Digital Content Protection) specifications. This IC provides a simple, low cost and high quality method of sending protected digital audio and video, providing end users with a truly all-digital experience. The ESS DVD player ICs can transmit the highest quality digital audio and video content over a simple, low cost cable to high resolution TVs and displays. At the same time, built in backward compatibility with DVI 1.0 allows the ESS HDMI ICs to connect to any DVI 1.0 display (DTV, plasma display, LCD TV, PC monitor).

The ES7120 incorporates an extremely flexible audio and video interface. An integrated color space converter allows direct connection to ESS DVD Decoder ICs via their 12 bit YCbCr and 8-bit BT 656 outputs. An industry standard S/PDIF accepts PCM encoded data as well as Dolby Digital, DTS and other formats capable of being sent over S/PDIF. Four I2S inputs support DVD Audio and decoded Dolby Digital input, enabling pure digital audio connection to A/V receivers.

The ES7120 comes pre-programmed with HDCP keys, greatly simplifying the manufacturing process, lowering costs, and providing the highest level of HDCP key security available.

ESS provides a reference design with necessary software modules to provide a complete solution for HDMI Transmission from DVD Players to HDTVs.

The ES7120 HDMI transmitter is available in an 80-pin Thin Quad Flat Pack (TQFP) package.

FEATURES

- HDMI 1.1, HDCP 1.1 and DVI 1.0 compliant transmitter
- Integrated TMDS core
- Proprietary video interface supports ESS DVD decoder IC's
 - 12-bit RGB/YCbCr 4:4:4
 - 8-bit YCbCr 4:2:2 (ITU.601 and 656)
 - 12-bit, dual-edge clocking input mode
 - YCbCr-to-RGB color space conversion
 - Input clock modifier (0.5x, 2x, 4x)
 - 4:2:2 to 4:4:4 up sampling
- High-End digital audio interface
 - 4 x I2S inputs accept Dolby Digital, DVD-Audio input (2-ch. 192kHz, 8-ch. 96kHz)
 - S/PDIF input supports PCM, Dolby Digital, DTS digital audio transmission (32-192kHz Fs sample rate)
 - IEC60958 or IEC61937 compatible.
 - Flexible, programmable I2S channel mapping
 - 2:1 and 4:1 Down-sampling to handle 96KHz and 192KHz Audio Streams.
- Master I2C interface for DDC connection simplifies board layout and lowers cost
- Integrated HDCP encryption engine for transmitting protected audio and video content
- Pre-programmed HDCP keys provide highest level of key security, simplify manufacturing
- Monitor Detection supported through Hot Plug and Receiver Detection
- Programmable Data Enable Generator
- Programmable Sync Extraction
- Flexible power management

SYSTEM BLOCK DIAGRAM

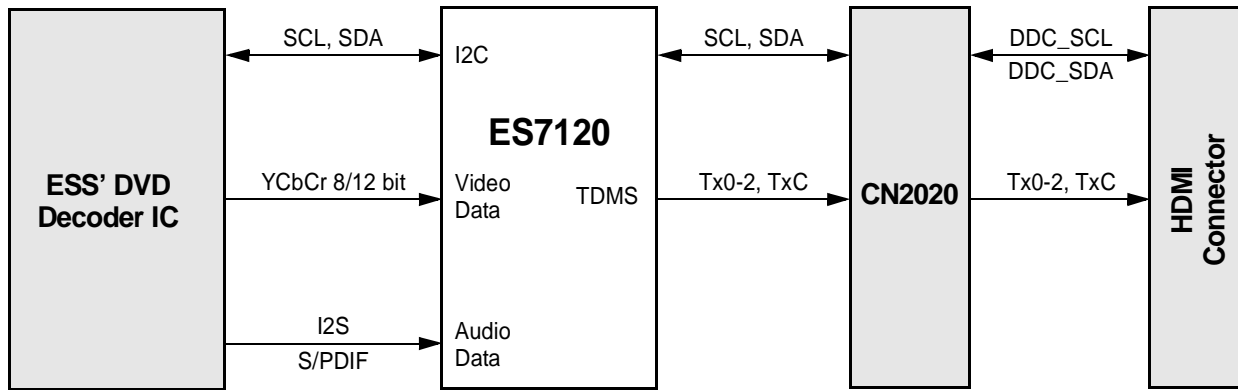

* CN2020 part by California Micro Devices

Figure 1 ES7120 System Block Diagram

ORDERING INFORMATION

Part Number	Description	Package
ES7120T	HDMI Transmitter	80-pin TQFP

The first letter T in the part number identifies the package type TQFP.

REFERENCE DESIGN AND SOFTWARE

ESS can provide a reference design and software modules to facilitate the implementation of a complete solution of a DVD player with HDMI Transmission to HDTVs. It can also be used as an example for further hardware-software system development.

The reference software consists of the following modules:

- System configuration
- System authentication
- EDID data reading



ESS Technology, Inc.
48401 Fremont Blvd.
Fremont, CA 94538
Tel: (510) 492-1088
Fax: (510) 492-1898

No part of this publication may be reproduced, stored in a retrieval system, transmitted, or translated in any form or by any means, electronic, mechanical, manual, optical, or otherwise, without the prior written permission of ESS Technology, Inc.

ESS Technology, Inc. makes no representations or warranties regarding the content of this document.

All specifications are subject to change without prior notice.

ESS Technology, Inc. assumes no responsibility for any errors contained herein.

U.S. patents pending.

MPEG is the Moving Picture Experts Group of the ISO/IEC. References to MPEG in this document refer to the ISO/IEC JTC1 SC29 committee draft ISO 11172 dated January 9, 1992.

Vibratto, SmartBright, SmartLogo, SmartColor, and Music Slideshow are trademarks of ESS Technology, Inc.

Dolby is a trademark of Dolby Laboratories, Inc.

Trusurround, Trusurround XT, SRS, and (o) symbol are trademarks of SRS Labs., Inc.

All other trademarks are trademarks of their respective companies and are used for identification purposes only.