



EN71NS128C0 Base MCP
Stacked Multi-Chip Product (MCP) Flash Memory and RAM
128 Megabit (8M x 16-bit) CMOS 1.8 Volt-only Simultaneous
Operation Burst Mode Flash Memory and
64 Megabit (4M x 16-bit) Pseudo Static RAM

Distinctive Characteristics
MCP Features

- **Power supply voltage of 1.7V to 1.95V**
- **High performance**
 - 70 ns @ random access
 - 7 ns @ burst access (108MHz)
- **Package**
 - 6.2 x 7.7 x 1.0mm 56 ball BGA
- **Operating Temperature**
 - 25°C to +85°C

General Description

The EN71NS series is a product line of stacked Multi-Chip Product (MCP) packages and consists of:

- E29NS128 (Burst mode) Flash memory die.
- Pseudo SRAM.

For detailed specifications, Please refer to the individual datasheets listed in the following table.

Device	Document
NOR Flash	EN29NS128
Pseudo SRAM	ENPSMC5

Product Selector Guide

128 Mb Flash Memories

Device-Model#	EN71NS128C0	pSRAM density	64M pSRAM
Flash Access time	70ns at Async. Mode 7ns at Burst Read	pSRAM Access time	70ns at Async. Mode 7ns at Burst Read
pSRAM Burst mode max frequency	108MHz	pSRAM Burst mode max frequency	108MHz
Package	56-ball BGA		



MCP Block Diagram

NOR FLASH + PSRAM DIAGRAM

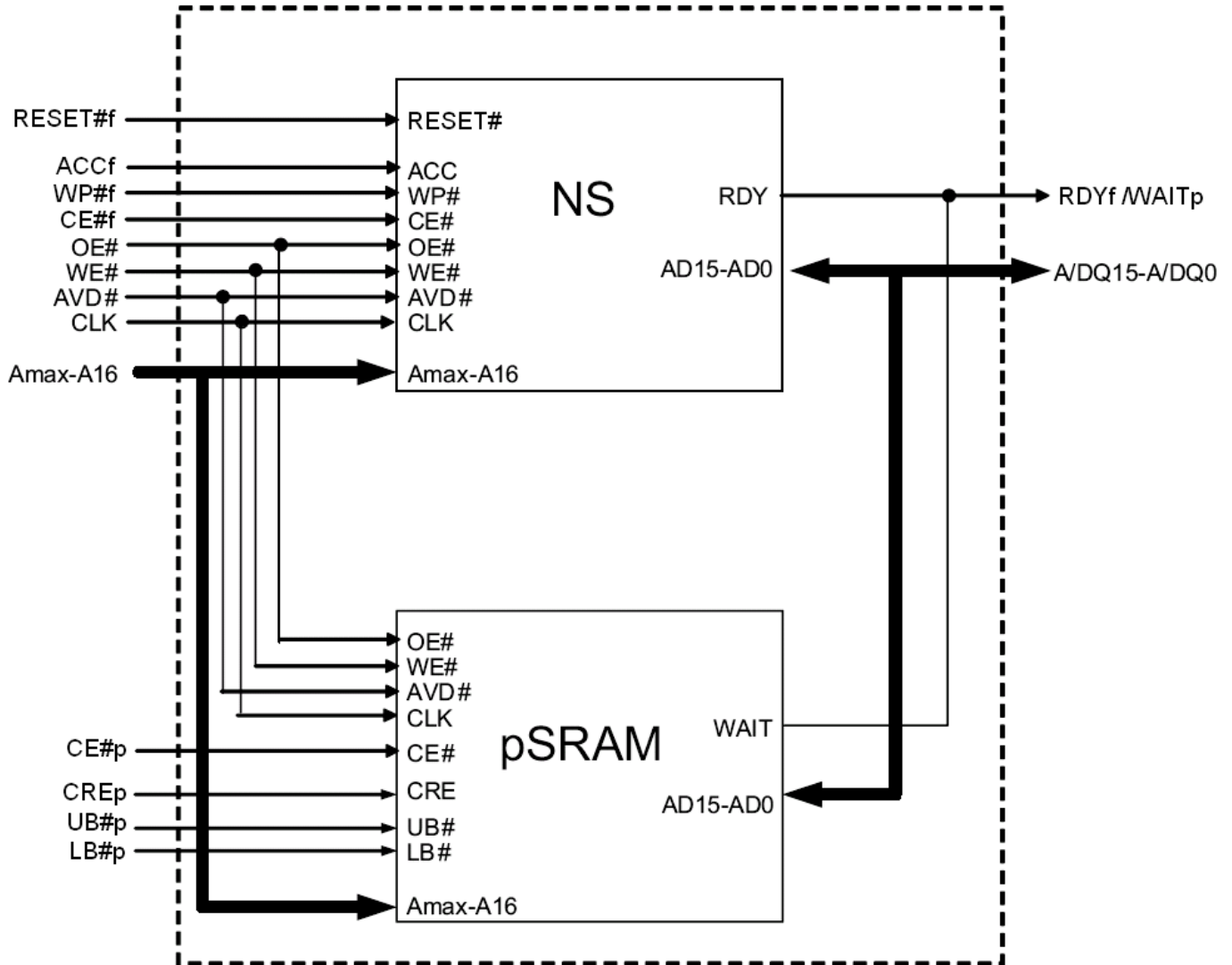

Note: Amax = A22



Connection Diagram

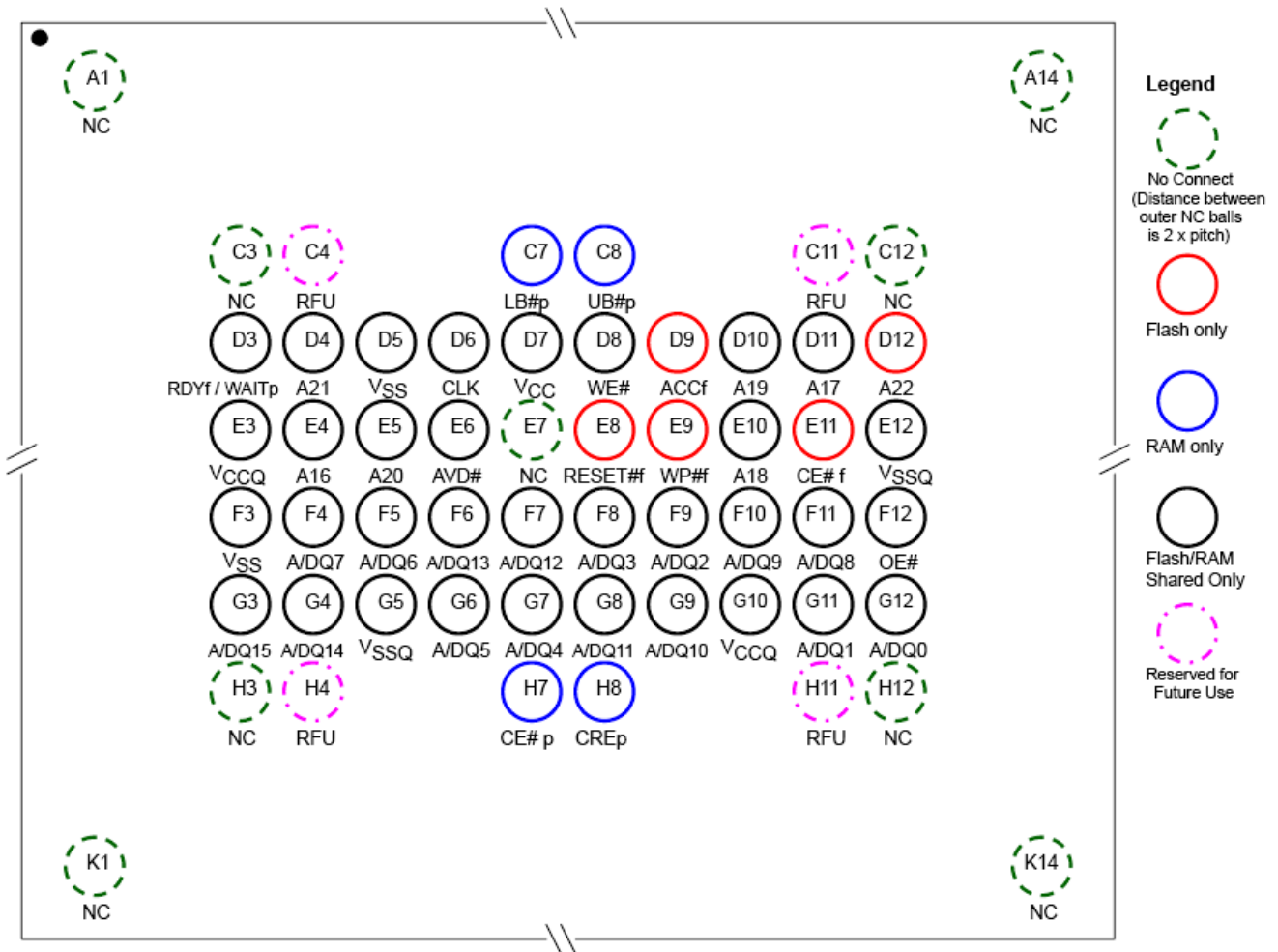

MCP	Flash-only Addresses	Shared Addresses	Shared ADQ Pins
EN71NS128C0	A22	A21 – A16	ADQ15 – ADQ0



Pin Description

Symbol	Description	Flash	pSRAM
A22–A16	Address Inputs	•	•
ADQ15–ADQ0	Multiplexed Address/Data	•	•
OE#	Output Enable input. Asynchronous relative to CLK for the Burst mode.	•	•
WE#	Write Enable input.	•	•
VSSQ/VSS	Ground	•	•
VCCQ/VCC	Device Power Supply (1.7 V–1.95 V).	•	•
NC	Not Contact; pin not connected internally	•	•
RDYf/WAITp	Ready output; indicates the status of the Burst read. Flash Memory RDY (using default “Active HIGH” configuration) V_{OL} = data invalid, V_{OH} = data valid. Note: The default polarity for the pSRAM WAIT signal is opposite the default polarity of the Flash RDY signal. pSRAM WAIT (using default “Active HIGH” configuration) V_{OL} = data valid, V_{OH} = data invalid. To match polarities, change bit 10 of the pSRAM Bus Configuration Register to 0 (Active LOW WAIT). Alternately, change bit 10 of the Flash Configuration Register to 0 (Active LOW RDY)	•	•
CLK	Clock input. In burst mode, after the initial word is output, subsequent active edges of CLK increment the internal address counter. Should be at V_{OL} or V_{IH} while in asynchronous mode.	•	•
AVD#	Address Valid input. Indicates to device that the valid address is present on the address inputs. V_{IL} = for asynchronous mode, indicates valid address; for burst mode, causes starting address to be latched on rising edge of CLK. V_{IH} = device ignores address inputs	•	•
RESET# f	Hardware reset input. V_{IL} = device resets and returns to reading array data	•	
WP#f	Hardware write protect input. V_{IL} = disables program and erase functions in the four outermost sectors. Should be at V_{IH} for all other conditions.	•	
ACCf	Accelerated input. At V_{HH} , accelerates programming; automatically places device in Accelerated Program mode. At V_{IL} , disables all program and erase functions. Should be at V_{IH} for all other conditions. (Applying high voltage on MCP package is prohibited; otherwise, internal RAM may be damaged easily!)	•	
CE# p	Chip Enable Input for pSRAM.		•
CE# f	Chip Enable Input for Flash. Asynchronous relative to CLK for the Burst mode.	•	
CREp	Control register enable (pSRAM).		•
LB#p	Lower byte enable. DQ7~DQ0 (pSRAM)		•
UB#p	Upper byte enable. DQ15~DQ8 (pSRAM)		•
RFU	Reserved for Future Use		



Operating Mode (For Asynchronous mode)

Asynchronous Mode BCR[15]=1	Power	CLK	ADV#	CE#	OE#	WE#	CRE	UB#/ LB#	WAIT2	A/DQ[15:0]
Read	Active	X		L	L	H	L	L	Low-z	Data out
Write	Active	X		L	X	L	L	L	High-z	Data in
Standby	Standby	H or L	X	H	X	X	L	X	High-z	High-z
No operation	Idle	X	X	L	X	X	L	X	Low-z	X
Configuration register write	Active	X		L	H	L	H	X	Low-z	High-z
Configuration register read	Active	X		L	L	H	H	L	Low-z	Config. Reg.out

Operating Mode (For Synchronous Burst mode)

Burst Mode BCR[15]=0	Power	CLK	ADV#	CE#	OE#	WE#	CRE	UB#/ LB#	WAIT	A/DQ[15:0]
Async read	Active	H or L		L	L	H	L	L	Low-z	Data out
Async write	Active	H or L		L	X	L	L	L	High-z	Data in
Standby	Standby	H or L	X	H	X	X	L	X	High-z	High-z
No operation	Idle	H or L	X	L	X	X	L	X	Low-z	X
Initial burst read	Active		L	L	X	H	L	L	Low-z	Address
Initial burst write	Active		L	L	H	L	L	X	Low-z	Address
Burst continue	Active		H	L	X	X	X	L	Low-z	Data out or Data in
Configuration register write	Active		L	L	H	L	H	X	Low	High-z
Configuration register read	Active		L	L	L	H	H	L	Low	Config. Reg.out

Note: X=don't care. H=logic high. L=logic low. V= Valid data



ORDERING INFORMATION

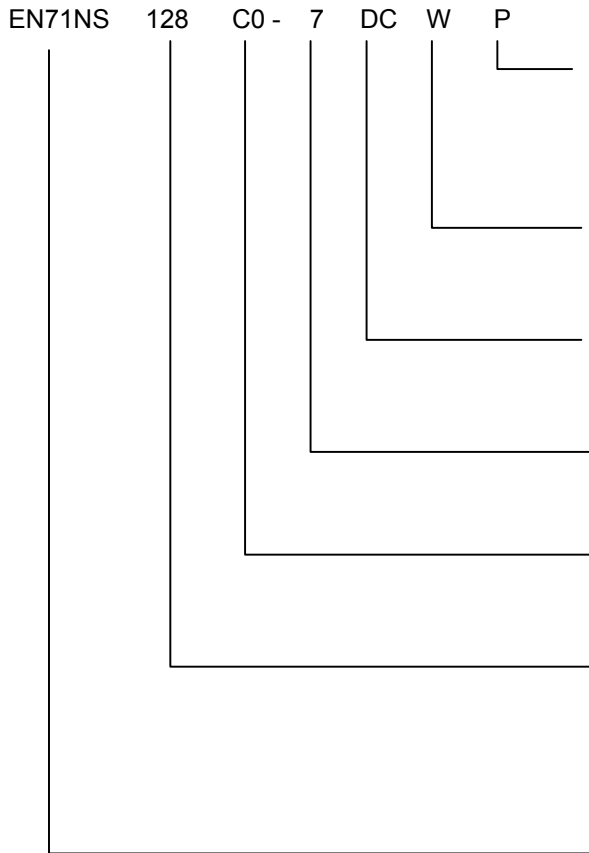

PACKAGING CONTENT

P = RoHS compliant

TEMPERATURE RANGE

W = Wireless (-25°C to +85°C)

PACKAGE

DC = 56-Ball BGA
0.50mm pitch, 6.2mm x 7.7mm package

BURST READ ACCESS TIME

7 = 108 MHz

Pseudo SRAM density

C0 = 64Mb

DENSITY

128 = 128Megabit (8M x 16 Bit)

BASE PART NUMBER

EN = Eon Silicon Solution Inc.
71NS = Multi-chip Product (MCP)
1.8V Simultaneous Read/Write,
Burst-mode Multiplexed Flash and RAM



PACKAGE MECHANICAL

56-ball Ball Grid Array (BGA) 6.2 x 7.7 x 1.0mm Package, pitch: 0.5mm, ball: 0.3mm

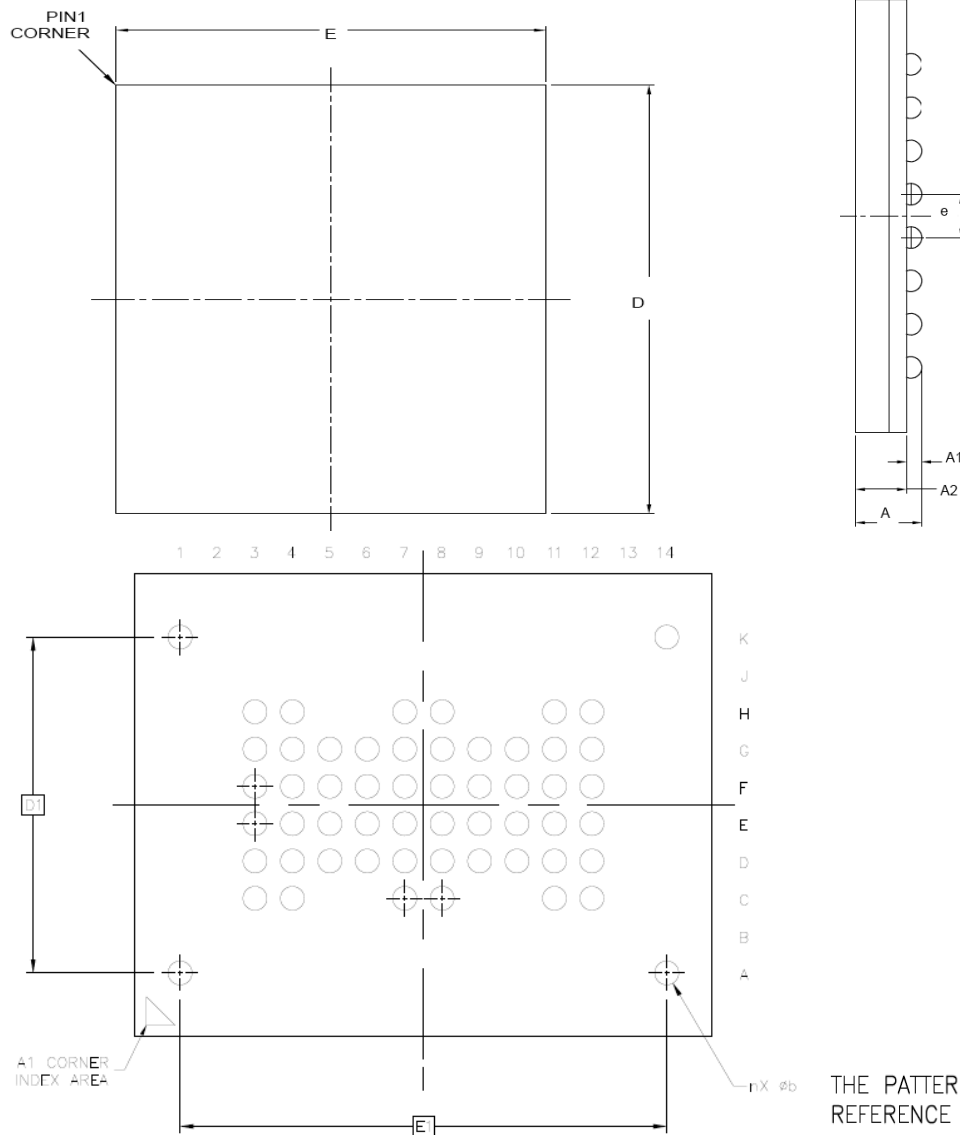

THE PATTERN OF PIN 1 FIDUCIAL IS FOR REFERENCE ONLY.

SYMBOL	DIMENSION IN MM		
	MIN.	NOR	MAX
A	---	---	1.00
A1	0.16	---	0.26
A2	0.676		
D	6.10	6.20	6.30
E	7.60	7.70	7.80
D1	4.5 BSC		
E1	6.5 BSC		
e	0.5 BSC		
b	0.27	---	0.37

Note : 1. Coplanarity: 0.1 mm



Revisions List

Revision No	Description	Date
A	Initial Release	2010/11/23
B	Change Pseudo SRAM from ENPSS64 to ENPSMC5.	2011/06/16