

32-bit ARM™ Cortex™-M3 based Microcontroller

FM3 MB9B320M Series

MB9BF324K/L/M, MB9BF322K/L/M, MB9BF321K/L/M

■ DESCRIPTION

The MB9B320M Series are highly integrated 32-bit microcontrollers dedicated for embedded controllers with low-power consumption mode and competitive cost.

These series are based on the ARM Cortex-M3 Processor with on-chip Flash memory and SRAM, and have peripheral functions such as various timers, ADCs, DACs and Communication Interfaces (USB, UART, CSIO, I²C, LIN).

The products which are described in this data sheet are placed into TYPE9 product categories in "FM3 Family PERIPHERAL MANUAL".

Note: ARM and Cortex are the trademarks of ARM Limited in the EU and other countries.



MB9B320M Series

■ FEATURES

- 32-bit ARM Cortex-M3 Core
 - Processor version: r2p1
 - Up to 72 MHz Frequency Operation
 - Integrated Nested Vectored Interrupt Controller (NVIC): 1 NMI (non-maskable interrupt) and 48 peripheral interrupts and 16 priority levels
 - 24-bit System timer (Sys Tick): System timer for OS task management

- On-chip Memories

[Flash memory]

- Dual operation Flash memory
 - Main area: Up to 256 Kbytes
 - Work area: 32 Kbytes
- Read cycle: 0 wait-cycle
- Security function for code protection

[SRAM]

This Series on-chip SRAM is composed of two independent SRAM (SRAM0, SRAM1). SRAM0 is connected to I-code bus or D-code bus of Cortex-M3 core. SRAM1 is connected to System bus.

- SRAM0: Up to 16 Kbytes
- SRAM1: Up to 16 Kbytes

- USB Interface

The USB interface is composed of Function and Host.

[USB function]

- USB2.0 Full-Speed supported
- Max 6 EndPoint supported
 - EndPoint 0 is control transfer
 - EndPoint 1, 2 can select Bulk-transfer, Interrupt-transfer or Isochronous-transfer
 - EndPoint 3 to 5 can select Bulk-transfer or Interrupt-transfer
 - EndPoint 1 to 5 are comprised of Double Buffers.

[USB host]

- USB2.0 Full/Low-speed supported
- Bulk-transfer, interrupt-transfer and Isochronous-transfer support
- USB Device connected/dis-connected automatic detection
- Automatic processing of the IN/OUT token handshake packet
- Max 256-byte packet-length supported
- Wake-up function supported

- Multi-function Serial Interface (Max 8channels)

- 4 channels with 16steps×9-bit FIFO (ch.0/1/3/4), 4 channels without FIFO (ch.2/5/6/7)
- Operation mode is selectable from the followings for each channel.
 - UART
 - CSIO
 - LIN
 - I²C

[UART]

- Full duplex double buffer
- Selection with or without parity supported
- Built-in dedicated baud rate generator
- External clock available as a serial clock
- Hardware Flow control : Automatically control the transmission/reception by CTS/RTS (only ch.4)
- Various error detection functions available (parity errors, framing errors, and overrun errors)

[CSIO]

- Full duplex double buffer
- Built-in dedicated baud rate generator
- Overrun error detection function available

[LIN]

- LIN protocol Rev.2.1 supported
- Full duplex double buffer
- Master/Slave mode supported
- LIN break field generation (can be changed to 13 to 16-bit length)
- LIN break delimiter generation (can be changed to 1 to 4-bit length)
- Various error detection functions available (parity errors, framing errors, and overrun errors)

[I²C]

Standard mode (Max 100kbps) / High-speed mode (Max 400kbps) supported

- DMA Controller (8channels)

The DMA Controller has an independent bus from the CPU, so CPU and DMA Controller can process simultaneously.

- 8 independently configured and operated channels
- Transfer can be started by software or request from the built-in peripherals
- Transfer address area: 32-bit (4 Gbytes)
- Transfer mode: Block transfer/Burst transfer/Demand transfer
- Transfer data type: byte/half-word/word
- Transfer block count: 1 to 16
- Number of transfers: 1 to 65536

- A/D Converter (Max 26channels)

[12-bit A/D Converter]

- Successive Approximation type
- Built-in 2units
- Conversion time: 0.8μs @ 5V
- Priority conversion available (priority at 2levels)
- Scanning conversion mode
- Built-in FIFO for conversion data storage (for SCAN conversion: 16steps, for Priority conversion: 4steps)

- D/A Converter (Max 2channels)

- R-2R type
- 10-bit resolution

MB9B320M Series

- **Base Timer (Max 8channels)**

Operation mode is selectable from the followings for each channel.

- 16-bit PWM timer
- 16-bit PPG timer
- 16/32-bit reload timer
- 16/32-bit PWC timer

- **General-Purpose I/O Port**

This series can use its pins as general-purpose I/O ports when they are not used for external bus or peripherals. Moreover, the port relocate function is built in. It can set which I/O port the peripheral function can be allocated to.

- Capable of pull-up control per pin
- Capable of reading pin level directly
- Built-in the port relocate function
- Up to 65 high-speed general-purpose I/O Ports @ 80pin Package
- Some ports are 5V tolerant.

- **Dual Timer (32/16-bit Down Counter)**

The Dual Timer consists of two programmable 32/16-bit down counters. Operation mode is selectable from the followings for each channel.

- Free-running
- Periodic (=Reload)
- One-shot

- **Quadrature Position/Revolution Counter (QPRC) (Max 2channels)**

The Quadrature Position/Revolution Counter (QPRC) is used to measure the position of the position encoder. Moreover, it is possible to use as the up/down counter.

- The detection edge of the three external event input pins AIN, BIN and ZIN is configurable.
- 16-bit position counter
- 16-bit revolution counter
- Two 16-bit compare registers

- **Multi-function Timer**

The Multi-function timer is composed of the following blocks.

- 16-bit free-run timer × 3ch./unit
- Input capture × 4ch./unit
- Output compare × 6ch./unit
- A/D activating compare × 3ch./unit
- Waveform generator × 3ch./unit
- 16-bit PPG timer × 3ch./unit

The following function can be used to achieve the motor control.

- PWM signal output function
- DC chopper waveform output function
- Dead time function
- Input capture function
- A/D convertor activate function
- DTIF (Motor emergency stop) interrupt function

- Real-time clock (RTC)

The Real-time clock can count Year/Month/Day/Hour/Minute/Second/A day of the week from 01 to 99.

- The interrupt function with specifying date and time (Year/Month/Day/Hour/Minute/Second/A day of the week.) is available. This function is also available by specifying only Year, Month, Day, Hour or Minute.
- Timer interrupt function after set time or each set time.
- Capable of rewriting the time with continuing the time count.
- Leap year automatic count is available.

- Watch Counter

The Watch counter is used for wake up from sleep and timer mode.

Interval timer: up to 64s (Max) @ Sub Clock : 32.768 kHz

- External Interrupt Controller Unit

- Up to 23 external interrupt input pins @ 80pin Package
- Include one non-maskable interrupt (NMI) input pin

- Watchdog Timer (2channels)

A watchdog timer can generate interrupts or a reset when a time-out value is reached.

This series consists of two different watchdogs, a "Hardware" watchdog and a "Software" watchdog.

The "Hardware" watchdog timer is clocked by the built-in low-speed CR oscillator. Therefore, the "Hardware" watchdog is active in any low-power consumption modes except RTC, STOP, Deep standby RTC, Deep standby STOP modes.

- CRC (Cyclic Redundancy Check) Accelerator

The CRC accelerator calculates the CRC which has a heavy software processing load, and achieves a reduction of the integrity check processing load for reception data and storage.

CCITT CRC16 and IEEE-802.3 CRC32 are supported.

- CCITT CRC16 Generator Polynomial: 0x1021
- IEEE-802.3 CRC32 Generator Polynomial: 0x04C11DB7

- Clock and Reset

[Clocks]

Selectable from five clock sources (2 external oscillators, 2 built-in CR oscillators, and Main PLL).

- Main Clock : 4 MHz to 48 MHz
- Sub Clock : 32.768 kHz
- Built-in high-speed CR Clock : 4 MHz
- Built-in low-speed CR Clock : 100 kHz
- Main PLL Clock

[Resets]

- Reset requests from INITX pin
- Power-on reset
- Software reset
- Watchdog timers reset
- Low-voltage detection reset
- Clock Super Visor reset

- Clock Super Visor (CSV)

Clocks generated by built-in CR oscillators are used to supervise abnormality of the external clocks.

- If external clock failure (clock stop) is detected, reset is asserted.
- If external frequency anomaly is detected, interrupt or reset is asserted.

MB9B320M Series

- Low-Voltage Detector (LVD)

This Series includes 2-stage monitoring of voltage on the VCC pins. When the voltage falls below the voltage that has been set, Low-Voltage Detector generates an interrupt or reset.

- LVD1: error reporting via interrupt
- LVD2: auto-reset operation

- Low-Power Consumption Mode

Six low-power consumption modes supported.

- SLEEP
- TIMER
- RTC
- STOP
- Deep standby RTC (selectable between keeping the value of RAM and not)
- Deep standby STOP (selectable between keeping the value of RAM and not)

- Debug

Serial Wire JTAG Debug Port (SWJ-DP)

- Unique ID

Unique value of the device (41 bits) is set.

- Power Supply

Wide range voltage : VCC = 2.7V to 5.5V
: USBVCC = 3.0V to 3.6V (when USB is used)
= 2.7V to 5.5V (when GPIO is used)

MB9B320M Series

■ PRODUCT LINEUP

● Memory size

Product name		MB9BF321K/L/M	MB9BF322K/L/M	MB9BF324K/L/M
On-chip Flash memory	Main area	64 Kbytes	128 Kbytes	256 Kbytes
	Work area	32 Kbytes	32 Kbytes	32 Kbytes
On-chip SRAM	SRAM0	8 Kbytes	8 Kbytes	16 Kbytes
	SRAM1	8 Kbytes	8 Kbytes	16 Kbytes
	Total	16 Kbytes	16 Kbytes	32 Kbytes

● Function

Product name		MB9BF321K MB9BF322K MB9BF324K	MB9BF321L MB9BF322L MB9BF324L	MB9BF321M MB9BF322M MB9BF324M
Pin count		48	64	80/96
CPU		Cortex-M3		
Freq.		72 MHz		
Power supply voltage range		2.7V to 5.5V		
USB2.0 (Function/Host)		1ch. (Max)		
DMAC		8ch.		
Multi-function Serial Interface (UART/CSIO/LIN/I ² C)		4ch. (Max) ch.0/1/3: FIFO ch.5: No FIFO (In ch.1/5, only UART and LIN are available.)	8ch. (Max) ch.0/1/3/4 FIFO ch.2/5/6/7: No FIFO (In ch.1, only UART and LIN are available.)	
Base Timer (PWC/Reload timer/PWM/PPG)		8ch. (Max)		
MF-Timer	A/D activation compare	3ch.	1 unit	
	Input capture	4ch.*		
	Free-run timer	3ch.		
	Output compare	6ch.		
	Waveform generator	3ch.		
	PPG	3ch.		
QPRC		1ch.	2ch. (Max)	
Dual Timer		1 unit		
Real-Time Clock		1 unit		
Watch Counter		1 unit		
CRC Accelerator		Yes		
Watchdog timer		1ch. (SW) + 1ch. (HW)		
External Interrupts		14pins (Max) + NMI × 1	19pins (Max) + NMI × 1	23pins (Max) + NMI × 1
I/O ports		35pins (Max)	50pins (Max)	65pins (Max)
12-bit A/D converter		14ch. (2 units)	23ch. (2 units)	26ch. (2 units)
10-bit D/A converter		2ch. (Max)		
CSV (Clock Super Visor)		Yes		
LVD (Low-Voltage Detector)		2ch.		
Built-in CR	High-speed	4 MHz (± 2%)		
	Low-speed	100 kHz (Typ)		
Debug Function		SWJ-DP		
Unique ID		Yes		

MB9B320M Series

*: The external input channel which can be used is shown as follows.

- ch.0 to ch.3 : MB9BF321M/F322M/F324M
- ch.0, ch.2, ch.3 : MB9BF321K/F322K/F324K, MB9BF321L/F322L/F324L

Note: All signals of the peripheral function in each product cannot be allocated by limiting the pins of package.
It is necessary to use the port relocate function of the I/O port according to your function use.

MB9B320M Series

■ PACKAGES

Package \ Product name	MB9BF321K MB9BF322K MB9BF324K	MB9BF321L MB9BF322L MB9BF324L	MB9BF321M MB9BF322M MB9BF324M
LQFP: FPT-48P-M49 (0.5mm pitch)	○	-	-
QFN: LCC-48P-M73 (0.5mm pitch)	○	-	-
LQFP: FPT-64P-M38 (0.5mm pitch)	-	○	-
LQFP: FPT-64P-M39 (0.65mm pitch)	-	○	-
QFN: LCC-64P-M24 (0.5mm pitch)	-	○	-
LQFP: FPT-80P-M37 (0.5mm pitch)	-	-	○
LQFP: FPT-80P-M40 (0.65mm pitch)	-	-	○
BGA: BGA-96P-M07 (0.5mm pitch)	-	-	○

○ : Supported

Note: See "■PACKAGE DIMENSIONS" for detailed information on each package.

MB9B320M Series

PIN ASSIGNMENT

- FPT-80P-M37/M40

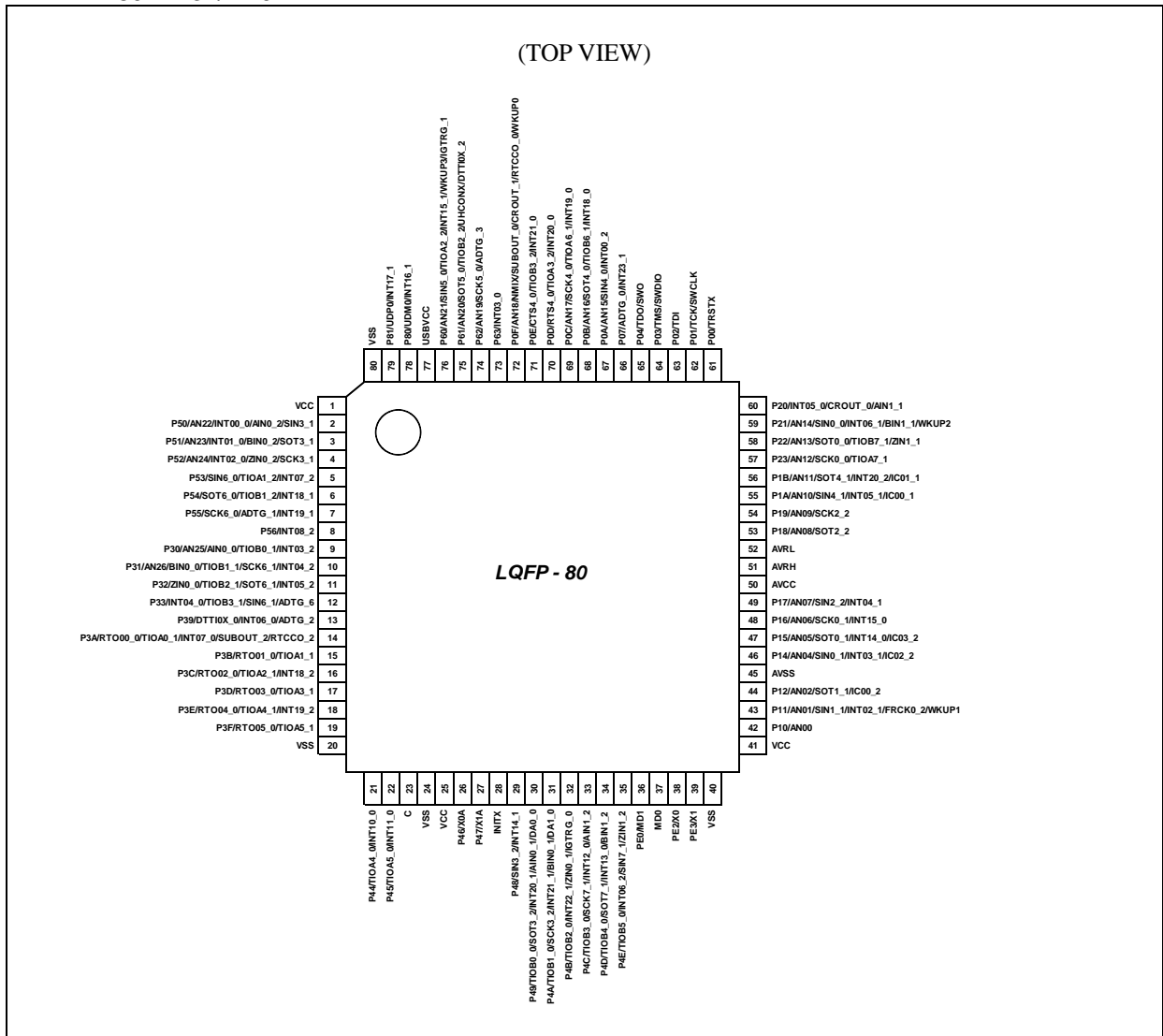

<Note>

The number after the underscore ("_") in pin names such as XXX_1 and XXX_2 indicates the relocated port number. For these pins, there are multiple pins that provide the same function for the same channel. Use the extended port function register (EPFR) to select the pin.

● FPT-64P-M38/M39

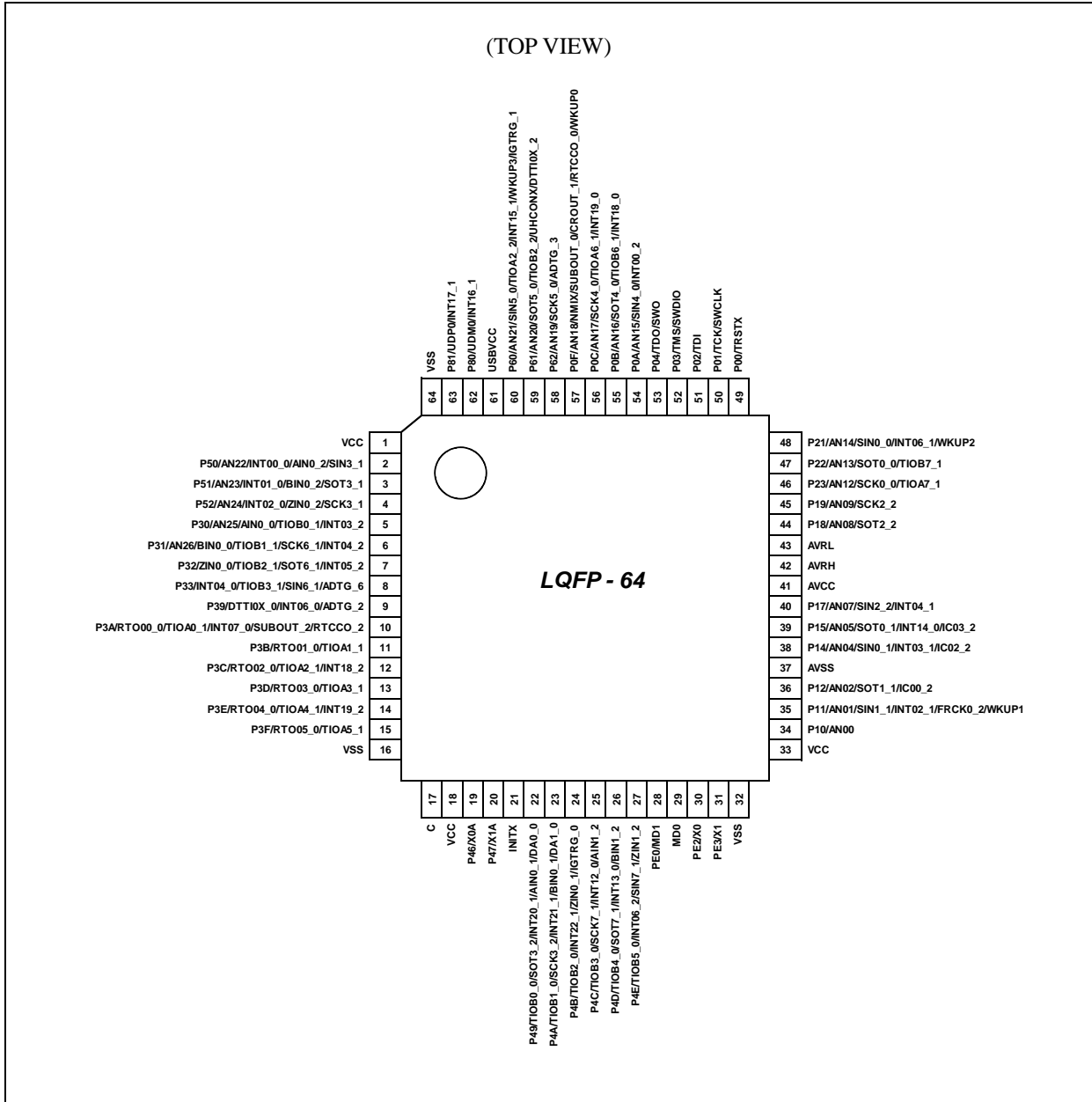

<Note>

The number after the underscore ("_") in pin names such as XXX_1 and XXX_2 indicates the relocated port number. For these pins, there are multiple pins that provide the same function for the same channel. Use the extended port function register (EPFR) to select the pin.

MB9B320M Series

- LCC-64P-M24

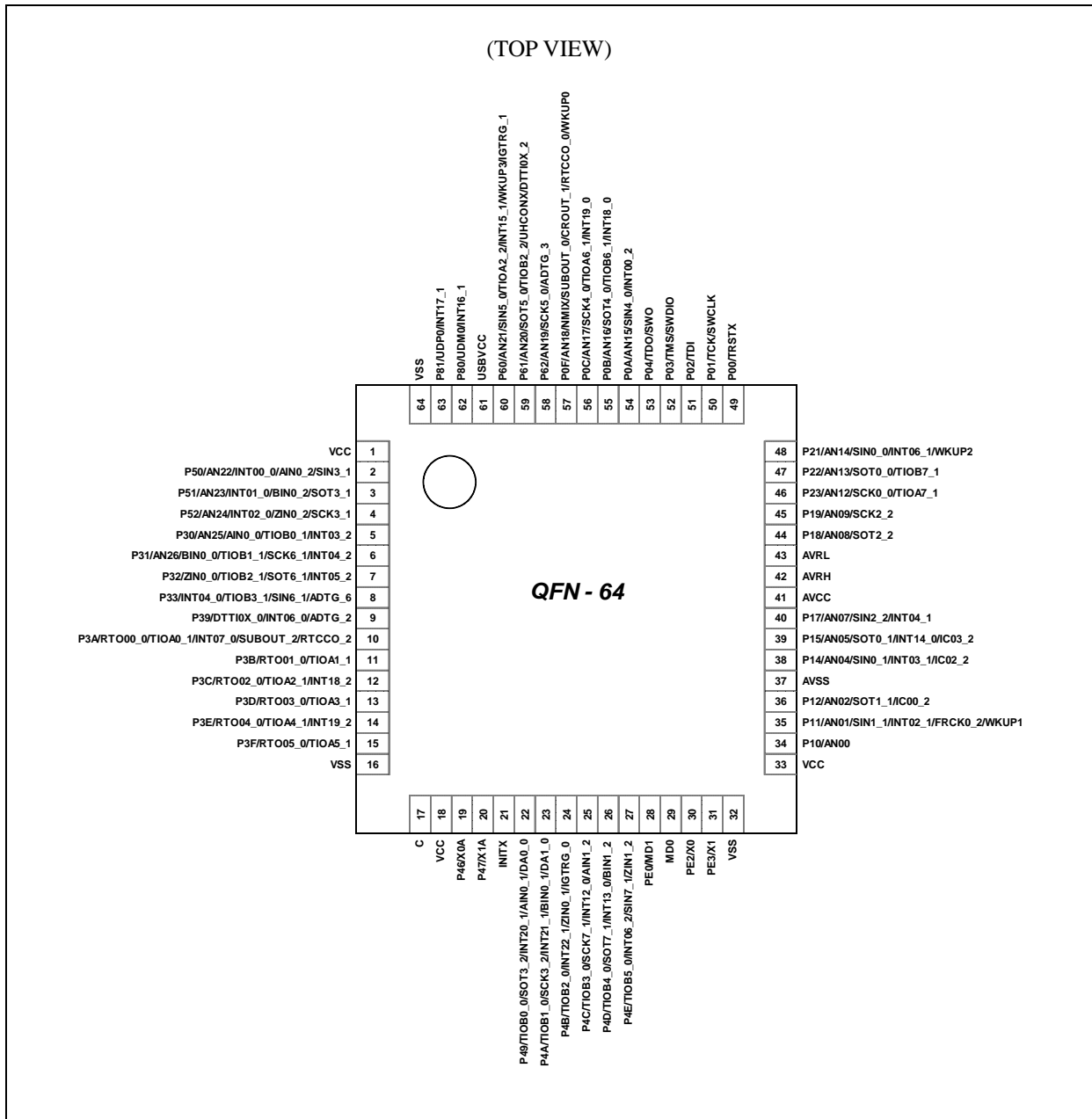

<Note>

The number after the underscore ("_") in pin names such as XXX_1 and XXX_2 indicates the relocated port number. For these pins, there are multiple pins that provide the same function for the same channel. Use the extended port function register (EPFR) to select the pin.

- FPT-48P-M49

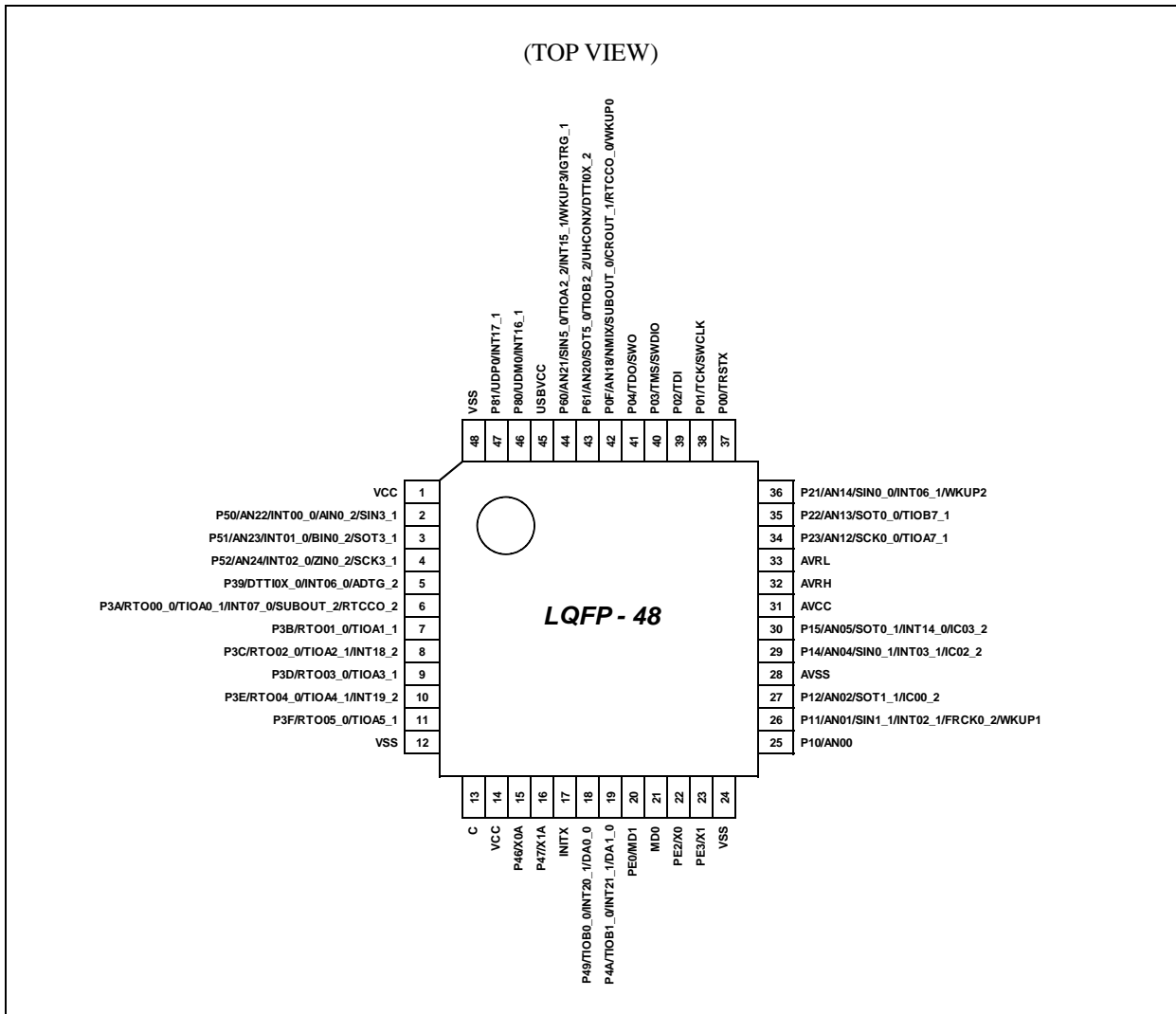

<Note>

The number after the underscore ("_") in pin names such as XXX_1 and XXX_2 indicates the relocated port number. For these pins, there are multiple pins that provide the same function for the same channel. Use the extended port function register (EPFR) to select the pin.

MB9B320M Series

- LCC-48P-M73

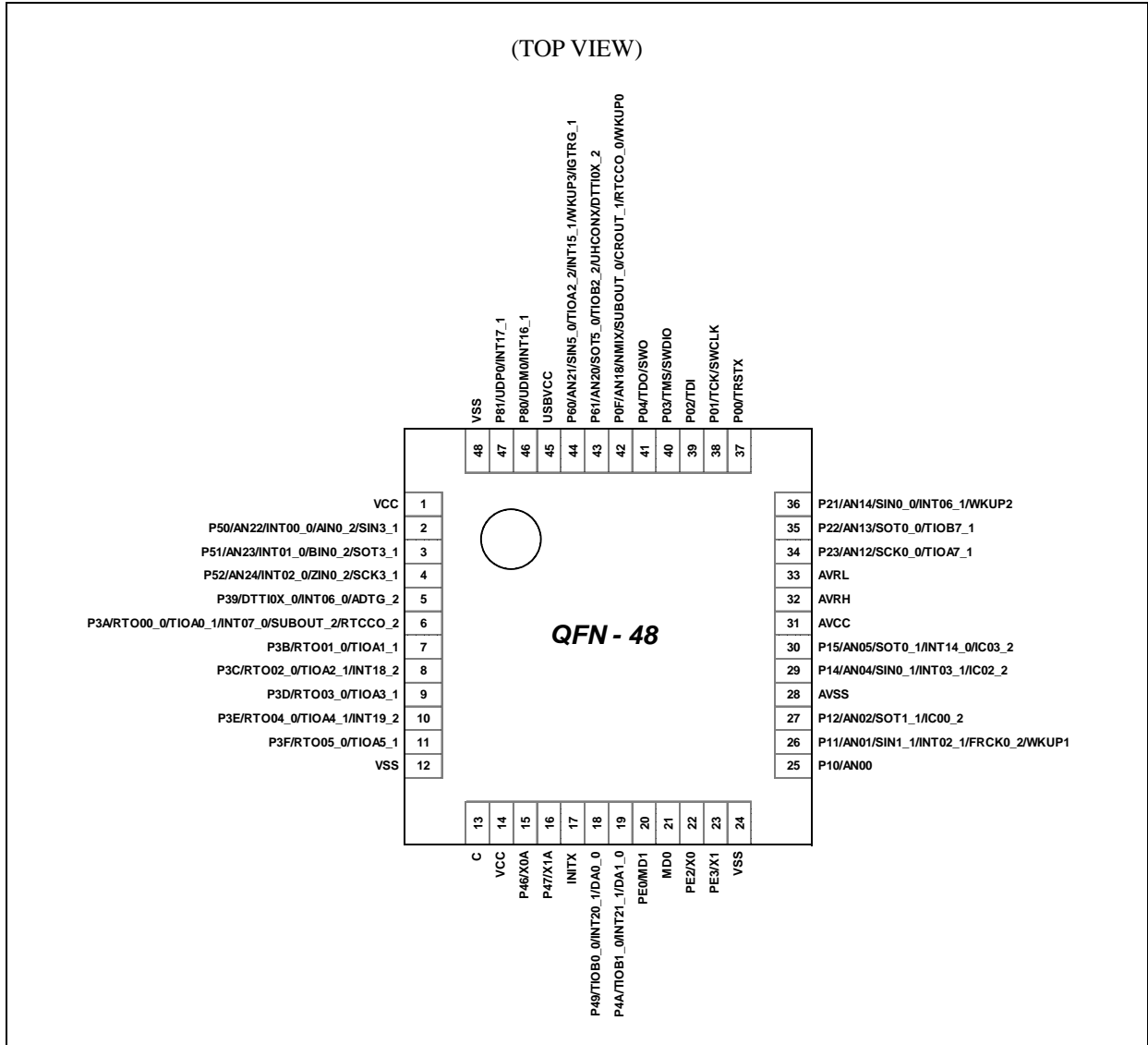

<Note>

The number after the underscore ("_") in pin names such as XXX_1 and XXX_2 indicates the relocated port number. For these pins, there are multiple pins that provide the same function for the same channel. Use the extended port function register (EPFR) to select the pin.

MB9B320M Series

● BGA-96P-M07

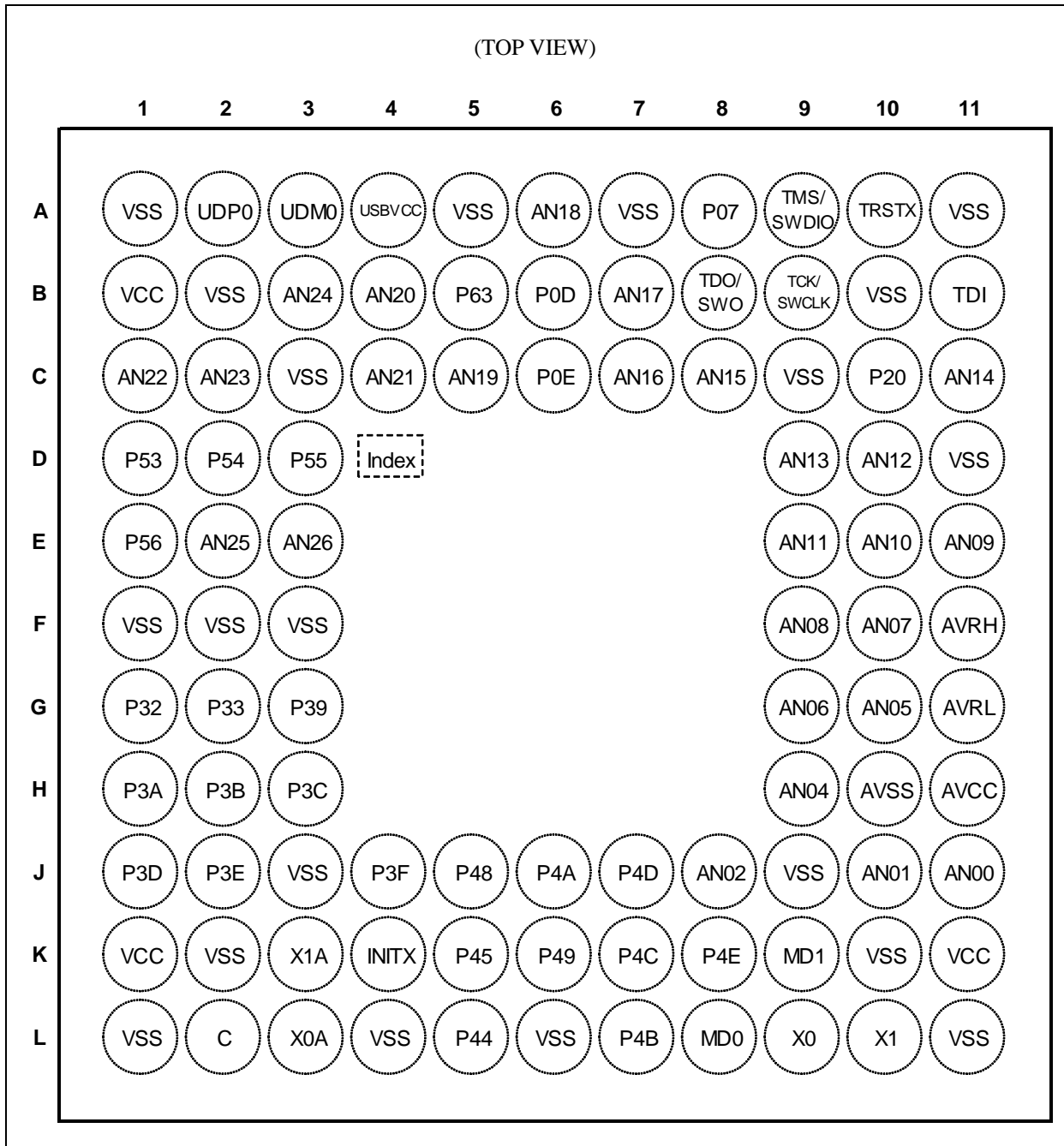

<Note>

The number after the underscore ("_") in pin names such as XXX_1 and XXX_2 indicates the relocated port number. For these pins, there are multiple pins that provide the same function for the same channel. Use the extended port function register (EPFR) to select the pin.

MB9B320M Series

■ LIST OF PIN FUNCTIONS

- List of pin numbers

The number after the underscore ("_") in pin names such as XXX_1 and XXX_2 indicates the relocated port number. For these pins, there are multiple pins that provide the same function for the same channel. Use the extended port function register (EPFR) to select the pin.

Pin No				Pin Name	I/O circuit type	Pin state type
LQFP-80	BGA-96	LQFP-64 QFN-64	LQFP-48 QFN-48			
1	B1	1	1	VCC	-	
2	C1	2	2	P50	F	N
				INT00_0		
				AIN0_2		
				SIN3_1		
3	C2	3	3	AN22	F	N
				P51		
				INT01_0		
				BIN0_2		
4	B3	4	4	SOT3_1 (SDA3_1)	F	N
				AN23		
				P52		
				INT02_0		
5	D1	-	-	ZIN0_2	E	L
				SCK3_1 (SCL3_1)		
				AN24		
				P53		
6	D2	-	-	SIN6_0	E	L
				TIOA1_2		
				INT07_2		
				P54		
7	D3	-	-	SOT6_0 (SDA6_0)	E	L
				TIOB1_2		
				INT18_1		
				P55		
8	E1	-	-	SCK6_0 (SCL6_0)	E	L
				ADTG_1		
				INT19_1		
				P56		
9	E2	5	-	INT08_2	F	N
				P30		
				AIN0_0		
				TIOB0_1		
				INT03_2		
				AN25		

MB9B320M Series

Pin No				Pin Name	I/O circuit type	Pin state type
LQFP-80	BGA-96	LQFP-64 QFN-64	LQFP-48 QFN-48			
10	E3	6	-	P31	F	N
				BIN0_0		
				TIOB1_1		
				SCK6_1 (SCL6_1)		
				INT04_2		
				AN26		
11	G1	7	-	P32	E	L
				ZIN0_0		
				TIOB2_1		
				SOT6_1 (SDA6_1)		
				INT05_2		
12	G2	8	-	P33	E	L
				INT04_0		
				TIOB3_1		
				SIN6_1		
				ADTG_6		
13	G3	9	5	P39	E	L
				DTTIOX_0		
				INT06_0		
				ADTG_2		
14	H1	10	6	P3A	G	L
				RTO00_0 (PPG00_0)		
				TIOA0_1		
				INT07_0		
				SUBOUT_2		
				RTCCO_2		
15	H2	11	7	P3B	G	K
				RTO01_0 (PPG00_0)		
				TIOA1_1		
16	H3	12	8	P3C	G	L
				RTO02_0 (PPG02_0)		
				TIOA2_1		
				INT18_2		
17	J1	13	9	P3D	G	K
				RTO03_0 (PPG02_0)		
				TIOA3_1		

MB9B320M Series

Pin No				Pin Name	I/O circuit type	Pin state type
LQFP-80	BGA-96	LQFP-64 QFN-64	LQFP-48 QFN-48			
18	J2	14	10	P3E	G	L
				RTO04_0 (PPG04_0)		
				TIOA4_1		
				INT19_2		
19	J4	15	11	P3F	G	K
				RTO05_0 (PPG04_0)		
				TIOA5_1		
20	L1	16	12	VSS	-	
21	L5	-	-	P44	G	L
				TIOA4_0		
				INT10_0		
22	K5	-	-	P45	G	L
				TIOA5_0		
				INT11_0		
23	L2	17	13	C	-	
24	L4	-	-	VSS	-	
25	K1	18	14	VCC	-	
26	L3	19	15	P46	D	F
				X0A		
27	K3	20	16	P47	D	G
				X1A		
28	K4	21	17	INTX	B	C
29	J5	-	-	P48	E	L
				INT14_1		
				SIN3_2		
30	K6	22	18	P49	L	L
				TIOB0_0		
				INT20_1		
			DA0_0			
			-	SOT3_2 (SDA3_2)		
				AIN0_1		
31	J6	23	19	P4A	L	L
				TIOB1_0		
				INT21_1		
			DA1_0			
			-	SCK3_2 (SCL3_2)		
				BIN0_1		

MB9B320M Series

Pin No				Pin Name	I/O circuit type	Pin state type
LQFP-80	BGA-96	LQFP-64 QFN-64	LQFP-48 QFN-48			
32	L7	24	-	P4B	E	L
				TIOB2_0		
				INT22_1		
				IGTRG_0		
				ZIN0_1		
33	K7	25	-	P4C	I*	L
				TIOB3_0		
				SCK7_1 (SCL7_1)		
				INT12_0		
				AIN1_2		
34	J7	26	-	P4D	I*	L
				TIOB4_0		
				SOT7_1 (SDA7_1)		
				INT13_0		
				BIN1_2		
35	K8	27	-	P4E	I*	L
				TIOB5_0		
				INT06_2		
				SIN7_1		
				ZIN1_2		
36	K9	28	20	MD1	C	E
				PE0		
37	L8	29	21	MD0	K	D
38	L9	30	22	X0	A	A
				PE2		
39	L10	31	23	X1	A	B
				PE3		
40	L11	32	24	VSS	-	-
41	K11	33	-	VCC	-	-
42	J11	34	25	P10	F	M
				AN00		
43	J10	35	26	P11	F	N
				AN01		
				SIN1_1		
				INT02_1		
				FRCK0_2		
				WKUP1		
44	J8	36	27	P12	F	M
				AN02		
				SOT1_1 (SDA1_1)		
				IC00_2		

MB9B320M Series

Pin No				Pin Name	I/O circuit type	Pin state type
LQFP-80	BGA-96	LQFP-64 QFN-64	LQFP-48 QFN-48			
45	H10	37	28	AVSS	-	
46	H9	38	29	P14	F	N
				AN04		
				INT03_1		
				IC02_2		
47	G10	39	30	SIN0_1	F	N
				P15		
				AN05		
				IC03_2		
48	G9	-	-	SOT0_1 (SDA0_1)	F	N
				INT14_0		
				P16		
				AN06		
49	F10	40	-	SCK0_1 (SCL0_1)	F	N
				INT15_0		
				P17		
				AN07		
50	H11	41	31	INT04_1	F	N
				SIN2_2		
				AVCC		
51	F11	42	32	AVRH	-	
52	G11	43	33	AVRL	-	
53	F9	44	-	P18	F	M
				AN08		
				SOT2_2 (SDA2_2)		
54	E11	45	-	P19	F	M
				AN09		
				SCK2_2 (SCL2_2)		
55	E10	-	-	P1A	F	N
				AN10		
				SIN4_1		
				INT05_1		
				IC00_1		

MB9B320M Series

Pin No				Pin Name	I/O circuit type	Pin state type
LQFP-80	BGA-96	LQFP-64 QFN-64	LQFP-48 QFN-48			
56	E9	-	-	P1B	F	N
				AN11		
				SOT4_1 (SDA4_1)		
				IC01_1		
				INT20_2		
57	D10	46	34	P23	F	M
				SCK0_0 (SCL0_0)		
				TIOA7_1		
				AN12		
58	D9	47	35	P22	F	M
				SOT0_0 (SDA0_0)		
				TIOB7_1		
				ZIN1_1		
				AN13		
59	C11	48	36	P21	F	N
				SIN0_0		
				INT06_1		
				WKUP2		
				BIN1_1		
				AN14		
60	C10	-	-	P20	E	N
				INT05_0		
				CROUT_0		
				AIN1_1		
61	A10	49	37	P00	E	J
				TRSTX		
62	B9	50	38	P01	E	J
				TCK		
				SWCLK		
63	B11	51	39	P02	E	J
				TDI		
64	A9	52	40	P03	E	J
				TMS		
				SWDIO		
65	B8	53	41	P04	E	J
				TDO		
				SWO		
66	A8	-	-	P07	E	L
				ADTG_0		
				INT23_1		

MB9B320M Series

Pin No				Pin Name	I/O circuit type	Pin state type
LQFP-80	BGA-96	LQFP-64 QFN-64	LQFP-48 QFN-48			
67	C8	54	-	P0A	J*	N
				SIN4_0		
				INT00_2		
				AN15		
68	C7	55	-	P0B	J*	N
				SOT4_0 (SDA4_0)		
				TIOB6_1		
				AN16		
69	B7	56	-	P0C	J*	N
				SCK4_0 (SCL4_0)		
				TIOA6_1		
				INT19_0		
70	B6	-	-	P0D	E	L
				RTS4_0		
				TIOA3_2		
				INT20_0		
71	C6	-	-	P0E	E	L
				CTS4_0		
				TIOB3_2		
				INT21_0		
72	A6	57	42	P0F	F	I
				NMIX		
				SUBOUT_0		
				CROUT_1		
				RTCCO_0		
				WKUP0		
AN18						
73	B5	-	-	P63	E	L
				INT03_0		
74	C5	58	-	P62	F	M
				SCK5_0 (SCL5_0)		
				ADTG_3		
				AN19		
75	B4	59	43	P61	F	M
				SOT5_0 (SDA5_0)		
				TIOB2_2		
				UHCONX		
				DTTIOX_2		
AN20						

MB9B320M Series

Pin No				Pin Name	I/O circuit type	Pin state type
LQFP-80	BGA-96	LQFP-64 QFN-64	LQFP-48 QFN-48			
76	C4	60	44	P60	J*	N
				SIN5_0		
				TIOA2_2		
				INT15_1		
				WKUP3		
				IGTRG_1		
				AN21		
77	A4	61	45	USBVCC	-	
78	A3	62	46	P80	H	H
				UDM0		
				INT16_1		
79	A2	63	47	P81	H	H
				UDP0		
				INT17_1		
80	A1	64	48	VSS	-	
-	A5, A7, A11, B2, B10, C3, C9, F1, F2, F3, J3, J9, K2, K10, L6	-	-	VSS	-	

*: 5V tolerant I/O

MB9B320M Series

- List of pin functions

The number after the underscore ("_") in pin names such as XXX_1 and XXX_2 indicates the relocated port number. For these pins, there are multiple pins that provide the same function for the same channel. Use the extended port function register (EPFR) to select the pin.

Pin function	Pin name	Function description	Pin No			
			LQFP-80	BGA-96	LQFP-64 QFN-64	LQFP-48 QFN-48
ADC	ADTG_0	A/D converter external trigger input pin	66	A8	-	-
	ADTG_1		7	D3	-	-
	ADTG_2		13	G3	9	13
	ADTG_3		74	C5	58	-
	ADTG_6		12	G2	8	-
	AN00		A/D converter analog input pin. ANxx describes ADC ch.xx.	42	J11	34
	AN01	43		J10	35	26
	AN02	44		J8	36	27
	AN04	46		H9	38	29
	AN05	47		G10	39	30
	AN06	48		G9	-	-
	AN07	49		F10	40	-
	AN08	53		F9	44	-
	AN09	54		E11	45	-
	AN10	55		E10	-	-
	AN11	56		E9	-	-
	AN12	57		D10	46	34
	AN13	58		D9	47	35
	AN14	59		C11	48	36
	AN15	67		C8	54	-
	AN16	68		C7	55	-
	AN17	69		B7	56	-
	AN18	72		A6	57	42
	AN19	74		C5	58	-
	AN20	75		B4	59	43
	AN21	76	C4	60	44	
	AN22	2	C1	2	2	
AN23	3	C2	3	3		
AN24	4	B3	4	4		
AN25	9	E2	5	-		
AN26	10	E3	6	-		

MB9B320M Series

Pin function	Pin name	Function description	Pin No			
			LQFP-80	BGA-96	LQFP-64 QFN-64	LQFP-48 QFN-48
Base Timer 0	TIOA0_1	Base timer ch.0 TIOA pin	14	H1	10	6
	TIOB0_0	Base timer ch.0 TIOB pin	30	K6	22	18
	TIOB0_1		9	E2	5	-
Base Timer 1	TIOA1_1	Base timer ch.1 TIOA pin	15	H2	11	7
	TIOA1_2		5	D1	-	-
	TIOB1_0	Base timer ch.1 TIOB pin	31	J6	23	19
	TIOB1_1		10	E3	6	-
	TIOB1_2		6	D2	-	-
Base Timer 2	TIOA2_1	Base timer ch.2 TIOA pin	16	H3	12	8
	TIOA2_2		76	C4	60	44
	TIOB2_0	Base timer ch.2 TIOB pin	32	L7	24	-
	TIOB2_1		11	G1	7	-
	TIOB2_2		75	B4	59	43
Base Timer 3	TIOA3_1	Base timer ch.3 TIOA pin	17	J1	13	9
	TIOA3_2		70	B6	-	-
	TIOB3_0	Base timer ch.3 TIOB pin	33	K7	25	-
	TIOB3_1		12	G2	8	-
	TIOB3_2		71	C6	-	-
Base Timer 4	TIOA4_0	Base timer ch.4 TIOA pin	21	L5	-	-
	TIOA4_1		18	J2	14	10
	TIOB4_0	Base timer ch.4 TIOB pin	34	J7	26	-
Base Timer 5	TIOA5_0	Base timer ch.5 TIOA pin	22	K5	-	-
	TIOA5_1		19	J4	15	11
	TIOB5_0	Base timer ch.5 TIOB pin	35	K8	27	-
Base Timer 6	TIOA6_1	Base timer ch.6 TIOA pin	69	B7	56	-
	TIOB6_1	Base timer ch.6 TIOB pin	68	C7	55	-
Base Timer 7	TIOA7_1	Base timer ch.7 TIOA pin	57	D10	46	34
	TIOB7_1	Base timer ch.7 TIOB pin	58	D9	47	35
Debugger	SWCLK	Serial wire debug interface clock input pin	62	B9	50	38
	SWDIO	Serial wire debug interface data input / output pin	64	A9	52	40
	SWO	Serial wire viewer output pin	65	B8	53	41
	TCK	J-TAG test clock input pin	62	B9	50	38
	TDI	J-TAG test data input pin	63	B11	51	39
	TDO	J-TAG debug data output pin	65	B8	53	41
	TMS	J-TAG test mode state input/output pin	64	A9	52	40
	TRSTX	J-TAG test reset input pin	61	A10	49	37

MB9B320M Series

Pin function	Pin name	Function description	Pin No			
			LQFP-80	BGA-96	LQFP-64 QFN-64	LQFP-48 QFN-48
External Interrupt	INT00_0	External interrupt request 00 input pin	2	C1	2	2
	INT00_2		67	C8	54	-
	INT01_0	External interrupt request 01 input pin	3	C2	3	3
	INT02_0	External interrupt request 02 input pin	4	B3	4	4
	INT02_1		43	J10	35	26
	INT03_0	External interrupt request 03 input pin	73	B5	-	-
	INT03_1		46	H9	38	29
	INT03_2		9	E2	5	-
	INT04_0	External interrupt request 04 input pin	12	G2	8	-
	INT04_1		49	F10	40	-
	INT04_2		10	E3	6	-
	INT05_0	External interrupt request 05 input pin	60	P20	-	-
	INT05_1		55	E10	-	-
	INT05_2		11	G1	7	-
	INT06_0	External interrupt request 06 input pin	13	G3	9	5
	INT06_1		59	C11	48	36
	INT06_2		35	K8	27	-
	INT07_0	External interrupt request 07 input pin	14	H1	10	6
	INT07_2		5	D1	-	-
	INT08_2	External interrupt request 08 input pin	8	E1	-	-
	INT10_0	External interrupt request 10 input pin	21	L5	-	-
	INT11_0	External interrupt request 11 input pin	22	K5	-	-
	INT12_0	External interrupt request 12 input pin	33	K7	25	-
	INT13_0	External interrupt request 13 input pin	34	J7	26	-
	INT14_0	External interrupt request 14 input pin	47	G10	39	30
	INT14_1		29	J5	-	-
	INT15_0	External interrupt request 15 input pin	48	G9	-	-
	INT15_1		76	C4	60	44
	INT16_1	External interrupt request 16 input pin	78	A3	62	46
	INT17_1	External interrupt request 17 input pin	79	A2	63	47
	INT18_0	External interrupt request 18 input pin	68	C7	55	-
	INT18_1		6	D2	-	-
	INT18_2		16	H3	12	8
INT19_0	External interrupt request 19 input pin	59	C11	56	-	
INT19_1		7	D3	-	-	
INT19_2		18	J2	14	10	

MB9B320M Series

Pin function	Pin name	Function description	Pin No				
			LQFP-80	BGA-96	LQFP-64 QFN-64	LQFP-48 QFN-48	
External Interrupt	INT20_0	External interrupt request 20 input pin	70	B6	-	-	
	INT20_1		30	K6	22	18	
	INT20_2		56	E9	-	-	
	INT21_0	External interrupt request 21 input pin	71	C6	-	-	
	INT21_1		31	J6	23	19	
	INT22_1	External interrupt request 22 input pin	32	L7	24	-	
	INT23_1	External interrupt request 23 input pin	66	A8	-	-	
	NMIX	Non-Maskable Interrupt input pin	72	A6	57	42	
GPIO	P00	General-purpose I/O port 0	61	A10	49	37	
	P01		62	B9	50	38	
	P02		63	B11	51	39	
	P03		64	A9	52	40	
	P04		65	B8	53	41	
	P07		66	A8	-	-	
	P0A		67	C8	54	-	
	P0B		68	C7	55	-	
	P0C		69	B7	56	-	
	P0D		70	B6	-	-	
	P0E		71	C6	-	-	
	P0F		72	A6	57	42	
	P10		General-purpose I/O port 1	42	J11	34	25
	P11			43	J10	35	26
	P12	44		J8	36	27	
	P14	46		H9	38	29	
	P15	47		G10	39	30	
	P16	48		G9	-	-	
	P17	49		F10	40	-	
	P18	53		F9	44	-	
	P19	54		E11	45	-	
	P1A	55		E10	-	-	
	P1B	56	E9	-	-		
	P20	General-purpose I/O port 2	60	C10	-	-	
	P21		59	C11	48	36	
	P22		58	D9	47	35	
	P23		57	D10	46	34	

MB9B320M Series

Pin function	Pin name	Function description	Pin No			
			LQFP-80	BGA-96	LQFP-64 QFN-64	LQFP-48 QFN-48
GPIO	P30	General-purpose I/O port 3	9	E2	5	-
	P31		10	E3	6	-
	P32		11	G1	7	-
	P33		12	G2	8	-
	P39		13	G3	9	5
	P3A		14	H1	10	6
	P3B		15	H2	11	7
	P3C		16	H3	12	8
	P3D		17	J1	13	9
	P3E		18	J2	14	10
	P3F		19	J4	15	11
	P44	General-purpose I/O port 4	21	L5	-	-
	P45		22	K5	-	-
	P46		26	L3	19	15
	P47		27	K3	20	16
	P48		29	J5	-	-
	P49		30	K6	22	18
	P4A		31	J6	23	19
	P4B		32	L7	24	-
	P4C		33	K7	25	-
	P4D		34	J7	26	-
	P4E		35	K8	27	-
	P50	General-purpose I/O port 5	2	C1	2	2
	P51		3	C2	3	3
	P52		4	B3	4	4
	P53		5	D1	-	-
	P54		6	D2	-	-
	P55		7	D3	-	-
	P56		8	E1	-	-
	P60	General-purpose I/O port 6	76	C4	60	44
	P61		75	B4	59	43
	P62		74	C5	58	-
	P63		73	B5	-	-
P80	General-purpose I/O port 8	78	A3	62	46	
P81		79	A2	63	47	
PE0	General-purpose I/O port E	36	K9	28	20	
PE2		38	L9	30	22	
PE3		39	L10	31	23	

MB9B320M Series

Pin function	Pin name	Function description	Pin No			
			LQFP-80	BGA-96	LQFP-64 QFN-64	LQFP-48 QFN-48
Multi-function Serial 0	SIN0_0	Multi-function serial interface ch.0 input pin	59	C11	48	36
	SIN0_1		46	H9	-	-
	SOT0_0 (SDA0_0)	Multi-function serial interface ch.0 output pin. This pin operates as SOT0 when it is used in a UART/CSIO/LIN (operation modes 0 to 3) and as SDA0 when it is used in an I ² C (operation mode 4).	58	D9	47	35
	SOT0_1 (SDA0_1)		47	G10	-	-
	SCK0_0 (SCL0_0)	Multi-function serial interface ch.0 clock I/O pin. This pin operates as SCK0 when it is used in a CSIO (operation mode 2) and as SCL0 when it is used in an I ² C (operation mode 4).	57	D10	46	34
	SCK0_1 (SCL0_1)		48	G9	-	-
Multi-function Serial 1	SIN1_1	Multi-function serial interface ch.1 input pin	43	J10	35	26
	SOT1_1 (SDA1_1)	Multi-function serial interface ch.1 output pin. This pin operates as SOT1 when it is used in a UART/LIN (operation modes 0,1,3) .	44	J8	36	27
Multi-function Serial 2	SIN2_2	Multi-function serial interface ch.2 input pin	49	F10	40	-
	SOT2_2 (SDA2_2)	Multi-function serial interface ch.2 output pin. This pin operates as SOT2 when it is used in a UART/CSIO/LIN (operation modes 0 to 3) and as SDA2 when it is used in an I ² C (operation mode 4).	53	F9	44	-
	SCK2_2 (SCL2_2)	Multi-function serial interface ch.2 clock I/O pin. This pin operates as SCK2 when it is used in a CSIO (operation mode 2) and as SCL2 when it is used in an I ² C (operation mode 4).	54	E11	45	-
Multi-function Serial 3	SIN3_1	Multi-function serial interface ch.3 input pin	2	C1	2	2
	SIN3_2		29	J5	-	-
	SOT3_1 (SDA3_1)	Multi-function serial interface ch.3 output pin. This pin operates as SOT3 when it is used in a UART/CSIO/LIN (operation modes 0 to 3) and as SDA3 when it is used in an I ² C (operation mode 4).	3	C2	3	3
	SOT3_2 (SDA3_2)		30	K6	-	-
	SCK3_1 (SCL3_1)	Multi-function serial interface ch.3 clock I/O pin. This pin operates as SCK3 when it is used in a CSIO (operation mode 2) and as SCL3 when it is used in an I ² C (operation mode 4).	4	B3	4	4
	SCK3_2 (SCL3_2)		31	J6	-	-

MB9B320M Series

Pin function	Pin name	Function description	Pin No			
			LQFP-80	BGA-96	LQFP-64 QFN-64	LQFP-48 QFN-48
Multi-function Serial 4	SIN4_0	Multi-function serial interface ch.4 input pin	67	C8	54	-
	SIN4_1		55	E10	-	-
	SOT4_0 (SDA4_0)	Multi-function serial interface ch.4 output pin. This pin operates as SOT4 when it is used in a UART/CSIO/LIN (operation modes 0 to 3) and as SDA4 when it is used in an I ² C (operation mode 4).	68	C7	55	-
	SOT4_1 (SDA4_1)		56	E9	-	-
	SCK4_0 (SCL4_0)	Multi-function serial interface ch.4 clock I/O pin. This pin operates as SCK4 when it is used in a CSIO (operation mode 2) and as SCL4 when it is used in an I ² C (operation mode 4).	69	B7	56	-
	RTS4_0	Multi-function serial interface ch.4 RTS output pin	70	B6	-	-
	CTS4_0	Multi-function serial interface ch.4 CTS input pin	71	C6	-	-
Multi-function Serial 5	SIN5_0	Multi-function serial interface ch.5 input pin	76	C4	60	44
	SOT5_0 (SDA5_0)	Multi-function serial interface ch.5 output pin. This pin operates as SOT5 when it is used in a UART/CSIO/LIN (operation modes 0 to 3) and as SDA5 when it is used in an I ² C (operation mode 4).	75	B4	59	43
	SCK5_0 (SCL5_0)	Multi-function serial interface ch.5 clock I/O pin. This pin operates as SCK5 when it is used in a CSIO (operation mode 2) and as SCL5 when it is used in an I ² C (operation mode 4).	74	C5	58	-
Multi-function Serial 6	SIN6_0	Multi-function serial interface ch.6 input pin	5	D1	-	-
	SIN6_1		12	G2	8	-
	SOT6_0 (SDA6_0)	Multi-function serial interface ch.6 output pin. This pin operates as SOT6 when it is used in a UART/CSIO/LIN (operation modes 0 to 3) and as SDA6 when it is used in an I ² C (operation mode 4).	6	D2	-	-
	SOT6_1 (SDA6_1)		11	G1	7	-
	SCK6_0 (SCL6_0)	Multi-function serial interface ch.6 clock I/O pin. This pin operates as SCK6 when it is used in a CSIO (operation mode 2) and as SCL6 when it is used in an I ² C (operation mode 4).	7	D3	-	-
	SCK6_1 (SCL6_1)		10	E3	6	-

MB9B320M Series

Pin function	Pin name	Function description	Pin No			
			LQFP-80	BGA-96	LQFP-64 QFN-64	LQFP-48 QFN-48
Multi-function Serial 7	SIN7_1	Multi-function serial interface ch.7 input pin	35	K8	27	-
	SOT7_1 (SDA7_1)	Multi-function serial interface ch.7 output pin. This pin operates as SOT7 when it is used in a UART/CSIO/LIN (operation modes 0 to 3) and as SDA7 when it is used in an I ² C (operation mode 4).	34	J7	26	-
	SCK7_1 (SCL7_1)	Multi-function serial interface ch.7 clock I/O pin. This pin operates as SCK7 when it is used in a CSIO (operation mode 2) and as SCL7 when it is used in an I ² C (operation mode 4).	33	K7	25	-
Multi-function Timer 0	DTTI0X_0	Input signal of waveform generator to control outputs RTO00 to RTO05 of Multi-function timer 0	13	G3	9	5
	DTTI0X_2		59	B4	43	75
	FRCK0_2	16-bit free-run timer ch.0 external clock input pin	43	J10	35	26
	IC00_1	16-bit input capture input pin of Multi-function timer 0. ICxx describes channel number.	55	E10	-	-
	IC00_2		44	J8	36	27
	IC01_1		56	E9	-	-
	IC02_2		46	H9	38	29
	IC03_2		47	G10	39	30
	RTO00_0 (PPG00_0)		Waveform generator output pin of Multi-function timer 0. This pin operates as PPG00 when it is used in PPG0 output mode.	14	H1	10
	RTO01_0 (PPG00_0)	Waveform generator output pin of Multi-function timer 0. This pin operates as PPG00 when it is used in PPG0 output mode.	15	H2	11	7
	RTO02_0 (PPG02_0)	Waveform generator output pin of Multi-function timer 0. This pin operates as PPG02 when it is used in PPG0 output mode.	16	H3	12	8
	RTO03_0 (PPG02_0)	Waveform generator output pin of Multi-function timer 0. This pin operates as PPG02 when it is used in PPG0 output mode.	17	J1	13	9
	RTO04_0 (PPG04_0)	Waveform generator output pin of Multi-function timer 0. This pin operates as PPG04 when it is used in PPG0 output mode.	18	J2	14	10
	RTO05_0 (PPG04_0)	Waveform generator output pin of Multi-function timer 0. This pin operates as PPG04 when it is used in PPG0 output mode.	19	J4	15	11
	IGTRG_0	PPG IGBT mode external trigger input pin	32	L7	24	-
IGTRG_1	76		C4	60	44	

MB9B320M Series

Pin function	Pin name	Function description	Pin No				
			LQFP-80	BGA-96	LQFP-64 QFN-64	LQFP-48 QFN-48	
Quadrature Position/ Revolution Counter 0	AIN0_0	QPRC ch.0 AIN input pin	9	E2	5	-	
	AIN0_1		30	K6	22	-	
	AIN0_2		2	C1	2	2	
	BIN0_0	QPRC ch.0 BIN input pin	10	E3	6	-	
			BIN0_1	31	J6	23	-
			BIN0_2	3	C2	3	3
	ZIN0_0	QPRC ch.0 ZIN input pin	11	G1	7	-	
			ZIN0_1	32	L7	24	-
			ZIN0_2	4	B3	4	4
Quadrature Position/ Revolution Counter 1	AIN1_1	QPRC ch.1 AIN input pin	60	C10	-	-	
	AIN1_2		33	K7	25	-	
	BIN1_1	QPRC ch.1 BIN input pin	59	C11	-	-	
	BIN1_2		34	J7	26	-	
	ZIN1_1	QPRC ch.1 ZIN input pin	58	D9	-	-	
	ZIN1_2		35	K8	27	-	
USB	UDM0	USB function/host D – pin	78	A3	62	46	
	UDP0	USB function/host D + pin	79	A2	63	47	
	UHCONX	USB external pull-up control pin	75	B4	59	43	
Real-time clock	RTCCO_0	0.5 seconds pulse output pin of Real-time clock	72	A6	57	42	
	RTCCO_2		14	H1	10	6	
	SUBOUT_0	Sub clock output pin	72	A6	57	42	
	SUBOUT_2		14	H1	10	6	
Low-Power Consumption Mode	WKUP0	Deep standby mode return signal input pin 0	72	A6	57	42	
	WKUP1	Deep standby mode return signal input pin 1	43	J10	35	26	
	WKUP2	Deep standby mode return signal input pin 2	59	C11	48	36	
	WKUP3	Deep standby mode return signal input pin 3	76	C4	60	44	
DAC	DA0	D/A converter ch.0 analog output pin	30	K6	22	18	
	DA1	D/A converter ch.1 analog output pin	31	J6	23	19	
RESET	INITX	External Reset Input pin. A reset is valid when INITX="L".	28	K4	21	17	

MB9B320M Series

Pin function	Pin name	Function description	Pin No			
			LQFP-80	BGA-96	LQFP-64 QFN-64	LQFP-48 QFN-48
Mode	MD0	Mode 0 pin. During normal operation, MD0="L" must be input. During serial programming to Flash memory, MD0="H" must be input.	37	L8	29	21
	MD1	Mode 1 pin. During serial programming to Flash memory, MD1="L" must be input.	36	K9	28	20
POWER	VCC	Power supply Pin	1	B1	1	1
	VCC	Power supply Pin	25	K1	18	14
	VCC	Power supply Pin	41	K11	33	-
	USBVCC	3.3V Power supply port for USB I/O	77	A4	61	45
GND	VSS	GND Pin	-	F1	-	-
	VSS	GND Pin	-	F2	-	-
	VSS	GND Pin	-	F3	-	-
	VSS	GND Pin	-	B2	-	-
	VSS	GND Pin	20	L1	16	12
	VSS	GND Pin	-	K2	-	-
	VSS	GND Pin	-	J3	-	-
	VSS	GND Pin	-	L6	-	-
	VSS	GND Pin	24	L4	-	-
	VSS	GND Pin	40	L11	32	24
	VSS	GND Pin	-	K10	-	-
	VSS	GND Pin	-	J9	-	-
	VSS	GND Pin	-	B10	-	-
	VSS	GND Pin	-	C9	-	-
	VSS	GND Pin	-	D11	-	-
	VSS	GND Pin	-	A11	-	-
	VSS	GND Pin	-	A7	-	-
	VSS	GND Pin	-	C3	-	-
	VSS	GND Pin	-	A5	-	-
VSS	GND Pin	80	A1	64	48	
CLOCK	X0	Main clock (oscillation) input pin	38	L9	30	22
	X0A	Sub clock (oscillation) input pin	26	L3	19	15
	X1	Main clock (oscillation) I/O pin	39	L10	31	23
	X1A	Sub clock (oscillation) I/O pin	27	K3	20	16
	CROUT_0	Built-in high-speed CR-osc clock output port	60	C10	-	-
	CROUT_1		72	A6	57	42
Analog POWER	AVCC	A/D converter and D/A converter analog power supply pin	50	H11	41	31
	AVRH	A/D converter analog reference voltage input pin	51	F11	42	32
Analog GND	AVSS	A/D converter and D/A converter GND pin	45	H10	37	28
	AVRL	A/D converter analog reference voltage input pin	52	G11	43	33
C pin	C	Power supply stabilization capacity pin	23	L2	17	13

MB9B320M Series

■ I/O CIRCUIT TYPE

Type	Circuit	Remarks
A	<p>The diagram for Type A shows two crystal oscillators, X1 and X0, connected to a central bus. A pull-up resistor R is connected to the bus. The bus branches into several functions: two digital outputs (one P-ch, one N-ch), a digital input with standby mode control, a clock input, and another digital input with standby mode control. Standby mode control is implemented using a combination of inverters and NAND gates.</p>	<p>It is possible to select the main oscillation / GPIO function</p> <p>When the main oscillation is selected.</p> <ul style="list-style-type: none"> • Oscillation feedback resistor : Approximately 1MΩ • With Standby mode control <p>When the GPIO is selected.</p> <ul style="list-style-type: none"> • CMOS level output. • CMOS level hysteresis input • With pull-up resistor control • With standby mode control • Pull-up resistor : Approximately 50kΩ • $I_{OH} = -4mA, I_{OL} = 4mA$
B	<p>The diagram for Type B shows a digital input pin connected to a pull-up resistor, followed by a resistor, a hysteresis input, and an inverter.</p>	<ul style="list-style-type: none"> • CMOS level hysteresis input • Pull-up resistor : Approximately 50kΩ

Type	Circuit	Remarks
C	<p>The diagram shows a square wave input connected to a resistor, which is then connected to an inverter. The output of this inverter is labeled 'Digital input'. Below this, an N-channel MOSFET is shown with its gate connected to the input line and its drain connected to the input line, and its source connected to ground. The output of this MOSFET is labeled 'Digital output'.</p>	<ul style="list-style-type: none"> • Open drain output • CMOS level hysteresis input
D	<p>The diagram shows a complex circuit with two oscillators, X1A and X0A. X1A is connected to a resistor R and a P-channel MOSFET. X0A is connected to a resistor R and a P-channel MOSFET. The circuit includes several digital inputs and outputs, including 'Digital input', 'Digital output', and 'Clock input'. It also features 'Standby mode control' signals and 'Pull-up resistor control' signals. The circuit uses a combination of P-channel and N-channel MOSFETs, resistors, and logic gates (AND, OR, NOT, NAND).</p>	<p>It is possible to select the sub oscillation / GPIO function</p> <p>When the sub oscillation is selected.</p> <ul style="list-style-type: none"> • Oscillation feedback resistor : Approximately 5MΩ • With Standby mode control <p>When the GPIO is selected.</p> <ul style="list-style-type: none"> • CMOS level output. • CMOS level hysteresis input • With pull-up resistor control • With standby mode control • Pull-up resistor : Approximately 50kΩ • $I_{OH} = -4mA$, $I_{OL} = 4mA$

MB9B320M Series

Type	Circuit	Remarks
E	<p>The diagram shows a CMOS output stage. A pull-up resistor R is connected to the output node. The output node is connected to the drain of a P-channel MOSFET (P-ch) and the drain of an N-channel MOSFET (N-ch). The gates of both MOSFETs are connected to a digital input signal through an AND gate. The AND gate is also controlled by a standby mode control signal. The output of the N-ch MOSFET is connected to ground. The output of the P-ch MOSFET is labeled 'Digital output'.</p>	<ul style="list-style-type: none"> • CMOS level output • CMOS level hysteresis input • With pull-up resistor control • With standby mode control • Pull-up resistor : Approximately 50kΩ • $I_{OH} = -4\text{mA}$, $I_{OL} = 4\text{mA}$ • When this pin is used as an I²C pin, the digital output P-ch transistor is always off
F	<p>The diagram shows a CMOS output stage with an analog input. A pull-up resistor R is connected to the output node. The output node is connected to the drain of a P-channel MOSFET (P-ch) and the drain of an N-channel MOSFET (N-ch). The gates of both MOSFETs are connected to a digital input signal through an AND gate. The AND gate is also controlled by a standby mode control signal. The gates of both MOSFETs are also connected to an analog input signal through another AND gate. This second AND gate is controlled by an input control signal. The output of the N-ch MOSFET is connected to ground. The output of the P-ch MOSFET is labeled 'Digital output'.</p>	<ul style="list-style-type: none"> • CMOS level output • CMOS level hysteresis input • With input control • Analog input • With pull-up resistor control • With standby mode control • Pull-up resistor : Approximately 50kΩ • $I_{OH} = -4\text{mA}$, $I_{OL} = 4\text{mA}$ • When this pin is used as an I²C pin, the digital output P-ch transistor is always off

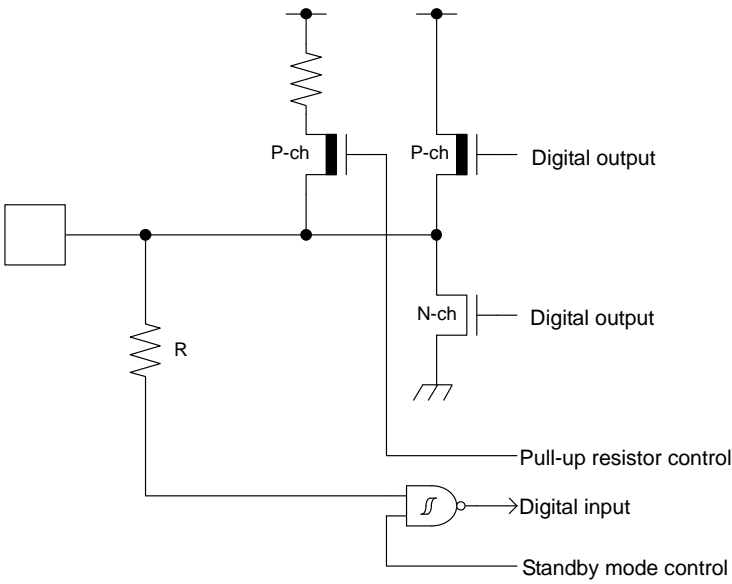
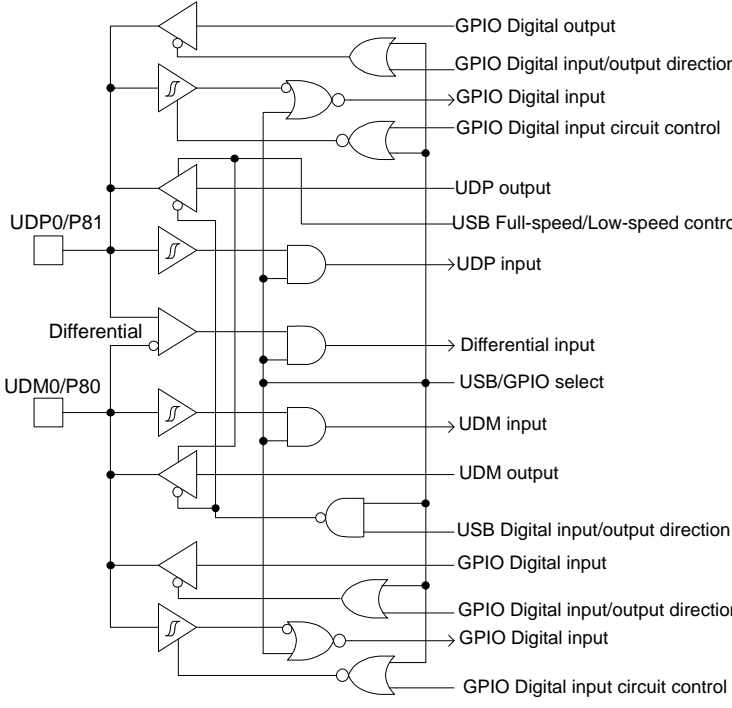
Type	Circuit	Remarks
G	 <p>The diagram shows a CMOS output stage. A pull-up resistor 'R' is connected to the output node. The output node is driven by a P-channel MOSFET (P-ch) and an N-channel MOSFET (N-ch). The P-ch MOSFET's gate is connected to a 'Pull-up resistor control' signal. The N-ch MOSFET's gate is connected to a 'Standby mode control' signal. The output node is also connected to a 'Digital output' terminal. A 'Digital input' terminal is connected to the output node through an inverter.</p>	<ul style="list-style-type: none"> • CMOS level output • CMOS level hysteresis input • With pull-up resistor control • With standby mode control • Pull-up resistor : Approximately 50kΩ • $I_{OH} = -12\text{mA}$, $I_{OL} = 12\text{mA}$
H	 <p>The diagram illustrates a complex digital I/O circuit. It features several input and output pins: UDP0/P81, Differential, UDM0/P80, and Digital input/output. The circuit includes multiple inverters, NAND gates, and OR gates. Key outputs include: GPIO Digital output, GPIO Digital input/output direction, GPIO Digital input, GPIO Digital input circuit control, UDP output, USB Full-speed/Low-speed control, UDP input, Differential input, USB/GPIO select, UDM input, UDM output, USB Digital input/output direction, GPIO Digital input, GPIO Digital input/output direction, and GPIO Digital input.</p>	<p>It is possible to select the USB I/O / GPIO function.</p> <p>When the USB I/O is selected.</p> <ul style="list-style-type: none"> • Full-speed, Low-speed control <p>When the GPIO is selected.</p> <ul style="list-style-type: none"> • CMOS level output • CMOS level hysteresis input • With standby mode control

MB9B320M Series

Type	Circuit	Remarks
I		<ul style="list-style-type: none"> • CMOS level output • CMOS level hysteresis input • 5V tolerant • With pull-up resistor control • With standby mode control • Pull-up resistor : Approximately 50kΩ • $I_{OH} = -4mA$, $I_{OL} = 4mA$ • Available to control PZR registers. • When this pin is used as an I²C pin, the digital output P-ch transistor is always off
J		<ul style="list-style-type: none"> • CMOS level output • CMOS level hysteresis input • With input control • Analog input • 5V tolerant • With pull-up resistor control • With standby mode control • Pull-up resistor : Approximately 50kΩ • $I_{OH} = -4mA$, $I_{OL} = 4mA$ • Available to control PZR registers. • When this pin is used as an I²C pin, the digital output P-ch transistor is always off
K		<p>CMOS level hysteresis input</p>

MB9B320M Series

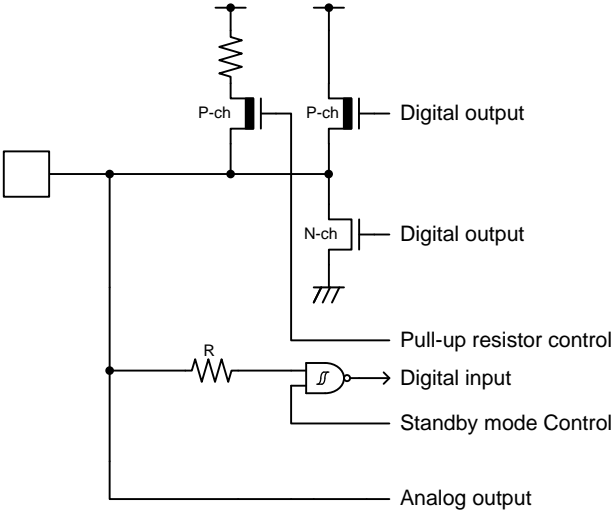
Type	Circuit	Remarks
L	 <p>The diagram shows a multiplexer circuit. A central input line from a square box splits into three paths. The top path goes to a P-channel MOSFET (P-ch) with a pull-up resistor connected to a supply rail. The middle path goes to the gates of two MOSFETs: a P-channel MOSFET (P-ch) and an N-channel MOSFET (N-ch). The P-ch MOSFET's drain is connected to a supply rail and labeled 'Digital output'. The N-ch MOSFET's drain is connected to a supply rail and labeled 'Digital output'. The N-ch MOSFET's source is connected to ground and labeled 'GND'. The bottom path goes to a resistor labeled 'R', which is connected to the input of an AND gate. The AND gate's other input is labeled 'Standby mode Control'. The output of the AND gate is labeled 'Digital input'. The main input line also continues downwards and is labeled 'Analog output'.</p>	<ul style="list-style-type: none"> • CMOS level output • CMOS level hysteresis input • With input control • Analog output • With pull-up resistor control • With standby mode control • Pull-up resistor : Approximately 50kΩ • $I_{OH} = -4\text{mA}$, $I_{OL} = 4\text{mA}$

■ HANDLING PRECAUTIONS

Any semiconductor devices have inherently a certain rate of failure. The possibility of failure is greatly affected by the conditions in which they are used (circuit conditions, environmental conditions, etc.). This page describes precautions that must be observed to minimize the chance of failure and to obtain higher reliability from your FUJITSU SEMICONDUCTOR semiconductor devices.

1. Precautions for Product Design

This section describes precautions when designing electronic equipment using semiconductor devices.

• Absolute Maximum Ratings

Semiconductor devices can be permanently damaged by application of stress (voltage, current, temperature, etc.) in excess of certain established limits, called absolute maximum ratings. Do not exceed these ratings.

• Recommended Operating Conditions

Recommended operating conditions are normal operating ranges for the semiconductor device. All the device's electrical characteristics are warranted when operated within these ranges.

Always use semiconductor devices within the recommended operating conditions. Operation outside these ranges may adversely affect reliability and could result in device failure.

No warranty is made with respect to uses, operating conditions, or combinations not represented on the data sheet. Users considering application outside the listed conditions are advised to contact their sales representative beforehand.

• Processing and Protection of Pins

These precautions must be followed when handling the pins which connect semiconductor devices to power supply and input/output functions.

(1) Preventing Over-Voltage and Over-Current Conditions

Exposure to voltage or current levels in excess of maximum ratings at any pin is likely to cause deterioration within the device, and in extreme cases leads to permanent damage of the device. Try to prevent such overvoltage or over-current conditions at the design stage.

(2) Protection of Output Pins

Shorting of output pins to supply pins or other output pins, or connection to large capacitance can cause large current flows. Such conditions if present for extended periods of time can damage the device.

Therefore, avoid this type of connection.

(3) Handling of Unused Input Pins

Unconnected input pins with very high impedance levels can adversely affect stability of operation. Such pins should be connected through an appropriate resistance to a power supply pin or ground pin.

• Latch-up

Semiconductor devices are constructed by the formation of P-type and N-type areas on a substrate. When subjected to abnormally high voltages, internal parasitic PNP junctions (called thyristor structures) may be formed, causing large current levels in excess of several hundred mA to flow continuously at the power supply pin. This condition is called latch-up.

CAUTION: The occurrence of latch-up not only causes loss of reliability in the semiconductor device, but can cause injury or damage from high heat, smoke or flame. To prevent this from happening, do the following:

- (1) Be sure that voltages applied to pins do not exceed the absolute maximum ratings. This should include attention to abnormal noise, surge levels, etc.
- (2) Be sure that abnormal current flows do not occur during the power-on sequence.

- **Observance of Safety Regulations and Standards**

Most countries in the world have established standards and regulations regarding safety, protection from electromagnetic interference, etc. Customers are requested to observe applicable regulations and standards in the design of products.

- **Fail-Safe Design**

Any semiconductor devices have inherently a certain rate of failure. You must protect against injury, damage or loss from such failures by incorporating safety design measures into your facility and equipment such as redundancy, fire protection, and prevention of over-current levels and other abnormal operating conditions.

- **Precautions Related to Usage of Devices**

FUJITSU SEMICONDUCTOR semiconductor devices are intended for use in standard applications (computers, office automation and other office equipment, industrial, communications, and measurement equipment, personal or household devices, etc.).

CAUTION: Customers considering the use of our products in special applications where failure or abnormal operation may directly affect human lives or cause physical injury or property damage, or where extremely high levels of reliability are demanded (such as aerospace systems, atomic energy controls, sea floor repeaters, vehicle operating controls, medical devices for life support, etc.) are requested to consult with sales representatives before such use. The company will not be responsible for damages arising from such use without prior approval.

2. Precautions for Package Mounting

Package mounting may be either lead insertion type or surface mount type. In either case, for heat resistance during soldering, you should only mount under FUJITSU SEMICONDUCTOR's recommended conditions. For detailed information about mount conditions, contact your sales representative.

- **Lead Insertion Type**

Mounting of lead insertion type packages onto printed circuit boards may be done by two methods: direct soldering on the board, or mounting by using a socket.

Direct mounting onto boards normally involves processes for inserting leads into through-holes on the board and using the flow soldering (wave soldering) method of applying liquid solder. In this case, the soldering process usually causes leads to be subjected to thermal stress in excess of the absolute ratings for storage temperature. Mounting processes should conform to FUJITSU SEMICONDUCTOR recommended mounting conditions.

If socket mounting is used, differences in surface treatment of the socket contacts and IC lead surfaces can lead to contact deterioration after long periods. For this reason it is recommended that the surface treatment of socket contacts and IC leads be verified before mounting.

- **Surface Mount Type**

Surface mount packaging has longer and thinner leads than lead-insertion packaging, and therefore leads are more easily deformed or bent. The use of packages with higher pin counts and narrower pin pitch results in increased susceptibility to open connections caused by deformed pins, or shorting due to solder bridges.

You must use appropriate mounting techniques. FUJITSU SEMICONDUCTOR recommends the solder reflow method, and has established a ranking of mounting conditions for each product. Users are advised to mount packages in accordance with FUJITSU SEMICONDUCTOR ranking of recommended conditions.

MB9B320M Series

- **Lead-Free Packaging**

CAUTION: When ball grid array (BGA) packages with Sn-Ag-Cu balls are mounted using Sn-Pb eutectic soldering, junction strength may be reduced under some conditions of use.

- **Storage of Semiconductor Devices**

Because plastic chip packages are formed from plastic resins, exposure to natural environmental conditions will cause absorption of moisture. During mounting, the application of heat to a package that has absorbed moisture can cause surfaces to peel, reducing moisture resistance and causing packages to crack. To prevent, do the following:

- (1) Avoid exposure to rapid temperature changes, which cause moisture to condense inside the product. Store products in locations where temperature changes are slight.
- (2) Use dry boxes for product storage. Products should be stored below 70% relative humidity, and at temperatures between 5°C and 30°C.
When you open Dry Package that recommends humidity 40% to 70% relative humidity.
- (3) When necessary, FUJITSU SEMICONDUCTOR packages semiconductor devices in highly moisture-resistant aluminum laminate bags, with a silica gel desiccant. Devices should be sealed in their aluminum laminate bags for storage.
- (4) Avoid storing packages where they are exposed to corrosive gases or high levels of dust.

- **Baking**

Packages that have absorbed moisture may be de-moisturized by baking (heat drying). Follow the FUJITSU SEMICONDUCTOR recommended conditions for baking.

Condition: 125°C/24 h

- **Static Electricity**

Because semiconductor devices are particularly susceptible to damage by static electricity, you must take the following precautions:

- (1) Maintain relative humidity in the working environment between 40% and 70%. Use of an apparatus for ion generation may be needed to remove electricity.
- (2) Electrically ground all conveyors, solder vessels, soldering irons and peripheral equipment.
- (3) Eliminate static body electricity by the use of rings or bracelets connected to ground through high resistance (on the level of 1 MΩ).
Wearing of conductive clothing and shoes, use of conductive floor mats and other measures to minimize shock loads is recommended.
- (4) Ground all fixtures and instruments, or protect with anti-static measures.
- (5) Avoid the use of styrofoam or other highly static-prone materials for storage of completed board assemblies.

3. Precautions for Use Environment

Reliability of semiconductor devices depends on ambient temperature and other conditions as described above.

For reliable performance, do the following:

(1) Humidity

Prolonged use in high humidity can lead to leakage in devices as well as printed circuit boards. If high humidity levels are anticipated, consider anti-humidity processing.

(2) Discharge of Static Electricity

When high-voltage charges exist close to semiconductor devices, discharges can cause abnormal operation. In such cases, use anti-static measures or processing to prevent discharges.

(3) Corrosive Gases, Dust, or Oil

Exposure to corrosive gases or contact with dust or oil may lead to chemical reactions that will adversely affect the device. If you use devices in such conditions, consider ways to prevent such exposure or to protect the devices.

(4) Radiation, Including Cosmic Radiation

Most devices are not designed for environments involving exposure to radiation or cosmic radiation. Users should provide shielding as appropriate.

(5) Smoke, Flame

CAUTION: Plastic molded devices are flammable, and therefore should not be used near combustible substances. If devices begin to smoke or burn, there is danger of the release of toxic gases. Customers considering the use of FUJITSU SEMICONDUCTOR products in other special environmental conditions should consult with sales representatives.

Please check the latest handling precautions at the following URL.

<http://edevice.fujitsu.com/fj/handling-e.pdf>

■ HANDLING DEVICES

- Power supply pins

In products with multiple VCC and VSS pins, respective pins at the same potential are interconnected within the device in order to prevent malfunctions such as latch-up. However, all of these pins should be connected externally to the power supply or ground lines in order to reduce electromagnetic emission levels, to prevent abnormal operation of strobe signals caused by the rise in the ground level, and to conform to the total output current rating.

Moreover, connect the current supply source with each Power supply pin and GND pin of this device at low impedance. It is also advisable that a ceramic capacitor of approximately 0.1 μ F be connected as a bypass capacitor between each Power supply pin and GND pin near this device.

- Stabilizing power supply voltage

A malfunction may occur when the power supply voltage fluctuates rapidly even though the fluctuation is within the recommended operating conditions of the VCC power supply voltage. As a rule, with voltage stabilization, suppress the voltage fluctuation so that the fluctuation in VCC ripple (peak-to-peak value) at the commercial frequency (50 Hz/60 Hz) does not exceed 10% of the VCC value in the recommended operating conditions, and the transient fluctuation rate does not exceed 0.1 V/ μ s when there is a momentary fluctuation on switching the power supply.

- Crystal oscillator circuit

Noise near the X0/X1 and X0A/X1A pins may cause the device to malfunction. Design the printed circuit board so that X0/X1, X0A/X1A pins, the crystal oscillator, and the bypass capacitor to ground are located as close to the device as possible.

It is strongly recommended that the PC board artwork be designed such that the X0/X1 and X0A/X1A pins are surrounded by ground plane as this is expected to produce stable operation.

- Using an external clock

When using an external clock as an input of the main clock, set X0/X1 to the external clock input, and input the clock to X0. X1(PE3) can be used as a general-purpose I/O port.

Similarly, when using an external clock as an input of the sub clock, set X0A/X1A to the external clock input, and input the clock to X0A. X1A (P47) can be used as a general-purpose I/O port.

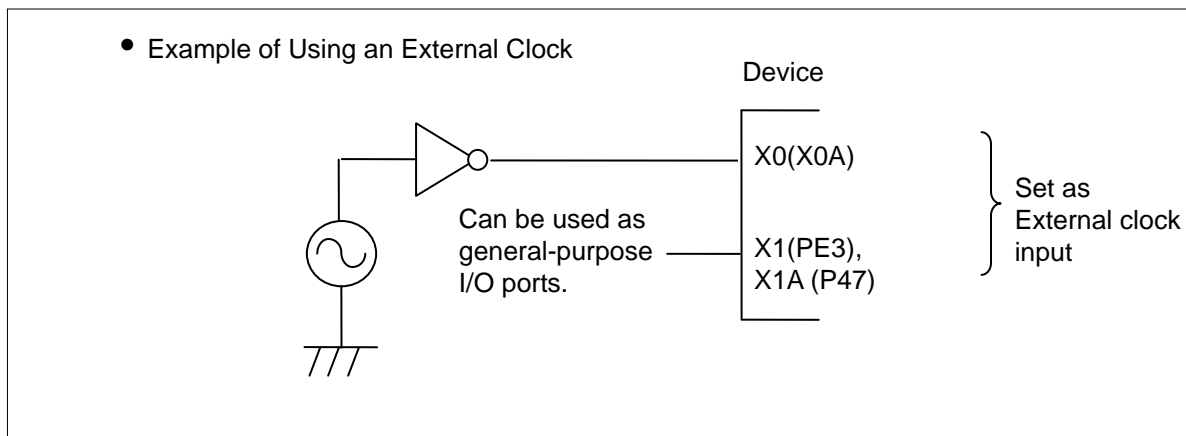

- Handling when using Multi-function serial pin as I²C pin

If it is using the multi-function serial pin as I²C pins, P-ch transistor of digital output is always disabled. However, I²C pins need to keep the electrical characteristic like other pins and not to connect to the external I²C bus system with power OFF.

- C Pin

This series contains the regulator. Be sure to connect a smoothing capacitor (C_s) for the regulator between the C pin and the GND pin. Please use a ceramic capacitor or a capacitor of equivalent frequency characteristics as a smoothing capacitor.

However, some laminated ceramic capacitors have the characteristics of capacitance variation due to thermal fluctuation (F characteristics and Y5V characteristics). Please select the capacitor that meets the specifications in the operating conditions to use by evaluating the temperature characteristics of a capacitor. A smoothing capacitor of about $4.7\mu\text{F}$ would be recommended for this series.

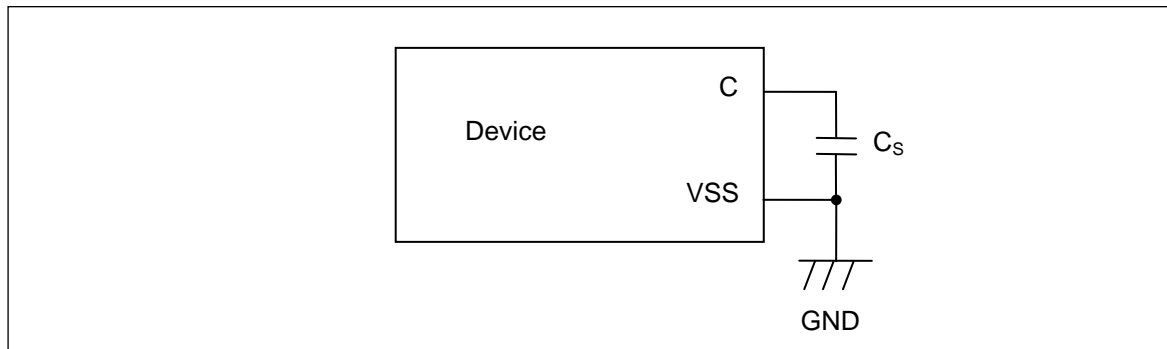

- Mode pins (MD0)

Connect the MD pin (MD0) directly to VCC or VSS pins. Design the printed circuit board such that the pull-up/down resistance stays low, as well as the distance between the mode pins and VCC pins or VSS pins is as short as possible and the connection impedance is low, when the pins are pulled-up/down such as for switching the pin level and rewriting the Flash memory data. It is because of preventing the device erroneously switching to test mode due to noise.

- Notes on power-on

Turn power on/off in the following order or at the same time.

If not using the A/D converter and D/A converter, connect $AVCC = VCC$ and $AVSS = VSS$.

Turning on : $VCC \rightarrow USBVCC$

$VCC \rightarrow AVCC \rightarrow AVRH$

Turning off : $USBVCC \rightarrow VCC$

$AVRH \rightarrow AVCC \rightarrow VCC$

- Serial Communication

There is a possibility to receive wrong data due to the noise or other causes on the serial communication. Therefore, design a printed circuit board so as to avoid noise.

Consider the case of receiving wrong data due to noise, perform error detection such as by applying a checksum of data at the end. If an error is detected, retransmit the data.

- Differences in features among the products with different memory sizes and between Flash memory products and MASK products

The electric characteristics including power consumption, ESD, latch-up, noise characteristics, and oscillation characteristics among the products with different memory sizes and between Flash memory products and MASK products are different because chip layout and memory structures are different.

If you are switching to use a different product of the same series, please make sure to evaluate the electric characteristics.

- Pull-Up function of 5V tolerant I/O

Please do not input the signal more than VCC voltage at the time of Pull-Up function use of 5V tolerant I/O.

MB9B320M Series

■ BLOCK DIAGRAM

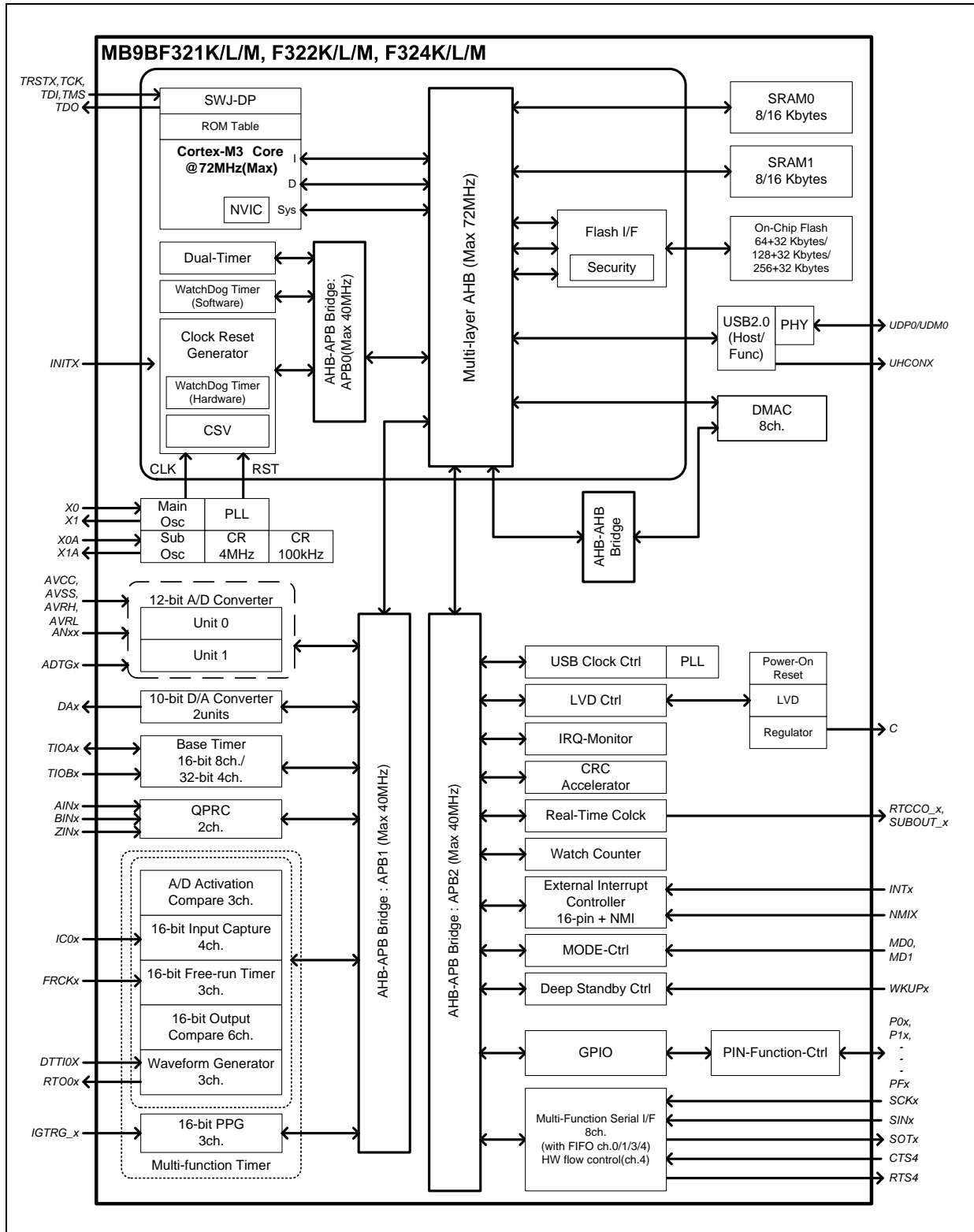

■ MEMORY SIZE

See " • Memory size" in "■PRODUCT LINEUP" to confirm the memory size.

MEMORY MAP

Memory Map (1)

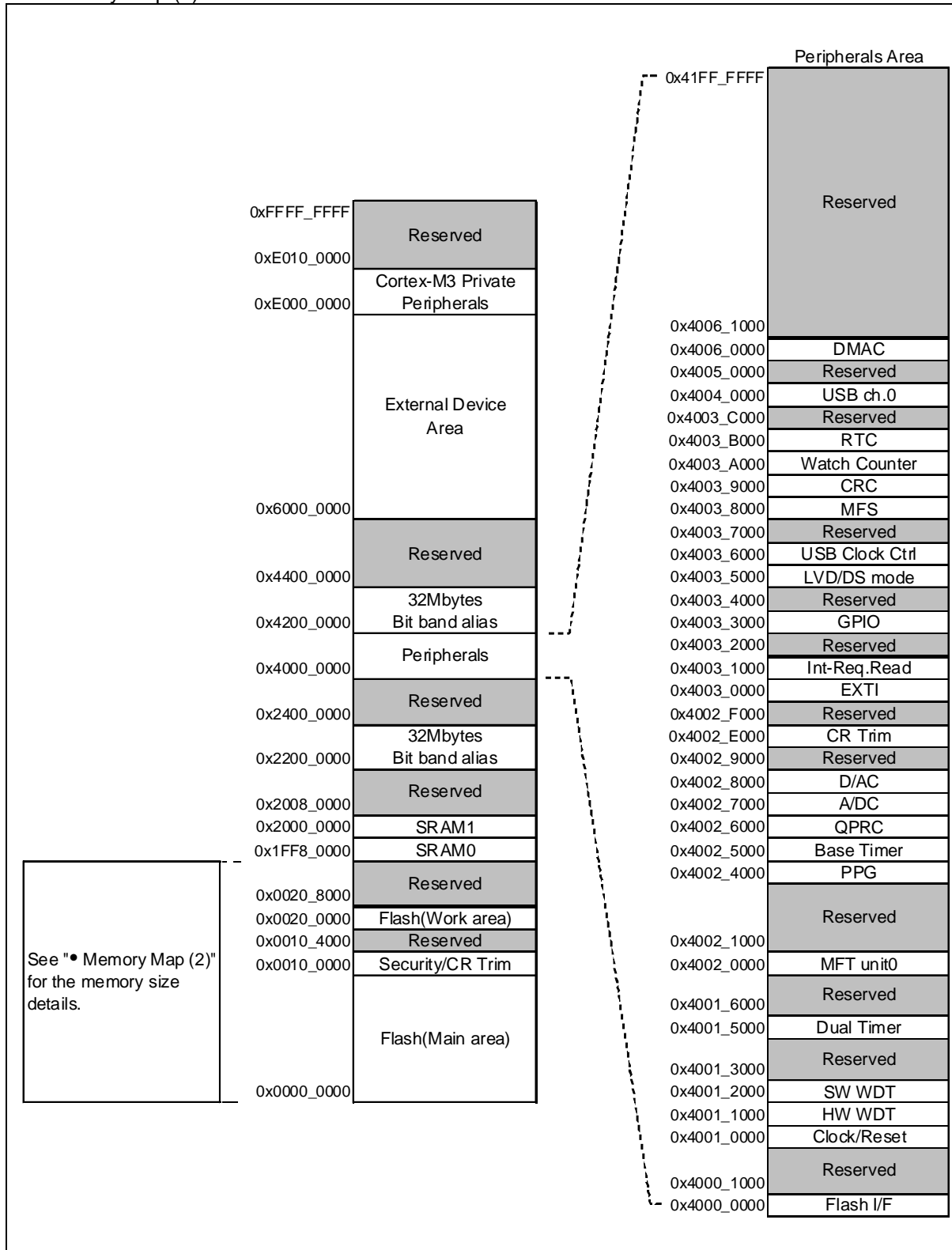

MB9B320M Series

● Memory Map (2)

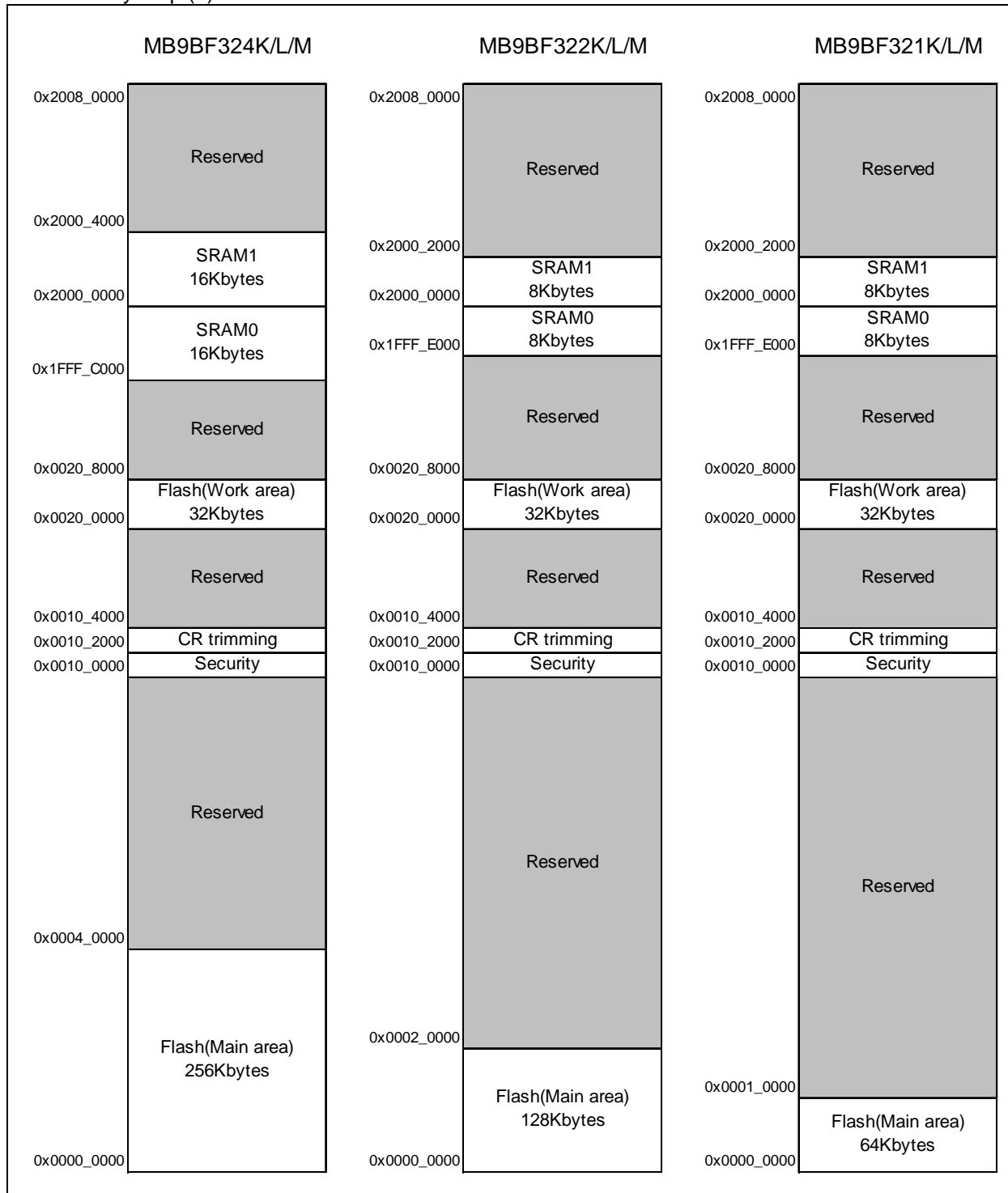

● Peripheral Address Map

Start address	End address	Bus	Peripherals
0x4000_0000	0x4000_0FFF	AHB	Flash Memory I/F register
0x4000_1000	0x4000_FFFF		Reserved
0x4001_0000	0x4001_0FFF	APB0	Clock/Reset Control
0x4001_1000	0x4001_1FFF		Hardware Watchdog timer
0x4001_2000	0x4001_2FFF		Software Watchdog timer
0x4001_3000	0x4001_4FFF		Reserved
0x4001_5000	0x4001_5FFF		Dual-Timer
0x4001_6000	0x4001_FFFF		Reserved
0x4002_0000	0x4002_0FFF		APB1
0x4002_1000	0x4002_3FFF	Reserved	
0x4002_4000	0x4002_4FFF	PPG	
0x4002_5000	0x4002_5FFF	Base Timer	
0x4002_6000	0x4002_6FFF	Quadrature Position/Revolution Counter (QPRC)	
0x4002_7000	0x4002_7FFF	A/D Converter	
0x4002_8000	0x4002_8FFF	D/A Converter	
0x4002_9000	0x4002_DFFF	Reserved	
0x4002_E000	0x4002_EFFF	Built-in CR trimming	
0x4002_F000	0x4002_FFFF	Reserved	
0x4003_0000	0x4003_0FFF	APB2	
0x4003_1000	0x4003_1FFF		Interrupt Source Check Register
0x4003_2000	0x4003_2FFF		Reserved
0x4003_3000	0x4003_3FFF		GPIO
0x4003_4000	0x4003_4FFF		Reserved
0x4003_5000	0x4003_57FF		Low-Voltage Detector
0x4003_5800	0x4003_5FFF		Deep standby mode Controller
0x4003_6000	0x4003_6FFF		USB clock generator
0x4003_7000	0x4003_7FFF		Reserved
0x4003_8000	0x4003_8FFF		Multi-function serial Interface
0x4003_9000	0x4003_9FFF		CRC
0x4003_A000	0x4003_AFFF		Watch Counter
0x4003_B000	0x4003_BFFF		Real-time clock
0x4003_C000	0x4003_FFFF		Reserved
0x4004_0000	0x4004_FFFF		AHB
0x4005_0000	0x4005_FFFF	Reserved	
0x4006_0000	0x4006_0FFF	DMAC register	
0x4006_1000	0x41FF_FFFF	Reserved	

■ PIN STATUS IN EACH CPU STATE

The terms used for pin status have the following meanings.

- INITX=0
This is the period when the INITX pin is the "L" level.
- INITX=1
This is the period when the INITX pin is the "H" level.
- SPL=0
This is the status that the standby pin level setting bit (SPL) in the standby mode control register (STB_CTL) is set to "0".
- SPL=1
This is the status that the standby pin level setting bit (SPL) in the standby mode control register (STB_CTL) is set to "1".
- Input enabled
Indicates that the input function can be used.
- Internal input fixed at "0"
This is the status that the input function cannot be used. Internal input is fixed at "L".
- Hi-Z
Indicates that the pin drive transistor is disabled and the pin is put in the Hi-Z state.
- Setting disabled
Indicates that the setting is disabled.
- Maintain previous state
Maintains the state that was immediately prior to entering the current mode.
If a built-in peripheral function is operating, the output follows the peripheral function.
If the pin is being used as a port, that output is maintained.
- Analog input is enabled
Indicates that the analog input is enabled.
- Trace output
Indicates that the trace function can be used.
- GPIO selected
In Deep standby mode, pins switch to the general-purpose I/O port.

● List of Pin Status

Pin status type	Function group	Power-on reset or low-voltage detection state	INITX input state	Device internal reset state	Run mode or SLEEP mode state	Timer mode, RTC mode, or STOP mode state		Deep standby RTC mode or Deep standby STOP mode state		Return from Deep standby mode state
		Power supply unstable	Power supply stable		Power supply stable	Power supply stable		Power supply stable		Power supply stable
		-	INITX = 0	INITX = 1	INITX = 1	INITX = 1		INITX = 1		INITX = 1
		-	-	-	-	SPL = 0	SPL = 1	SPL = 0	SPL = 1	-
A	GPIO selected	Setting disabled	Setting disabled	Setting disabled	Maintain previous state	Maintain previous state	Hi-Z / Internal input fixed at "0"	GPIO selected Internal input fixed at "0"	Hi-Z / Internal input fixed at "0"	GPIO selected
	Main crystal oscillator input pin/ External main clock input selected	Input enabled	Input enabled	Input enabled	Input enabled	Input enabled	Input enabled	Input enabled	Input enabled	Input enabled
B	GPIO selected	Setting disabled	Setting disabled	Setting disabled	Maintain previous state	Maintain previous state	Hi-Z / Internal input fixed at "0"	GPIO selected Internal input fixed at "0"	Hi-Z / Internal input fixed at "0"	GPIO selected
	External main clock input selected	Setting disabled	Setting disabled	Setting disabled	Maintain previous state	Maintain previous state	Hi-Z / Internal input fixed at "0"	Maintain previous state	Hi-Z / Internal input fixed at "0"	Maintain previous state
	Main crystal oscillator output pin	Hi-Z / Internal input fixed at "0" / or Input enable	Hi-Z / Internal input fixed at "0"	Hi-Z / Internal input fixed at "0"	Maintain previous state/When oscillation stops*1, Hi-Z / Internal input fixed at "0"	Maintain previous state/When oscillation stops*1, Hi-Z / Internal input fixed at "0"	Maintain previous state/When oscillation stops*1, Hi-Z / Internal input fixed at "0"	Maintain previous state/When oscillation stops*1, Hi-Z / Internal input fixed at "0"	Maintain previous state/When oscillation stops*1, Hi-Z / Internal input fixed at "0"	Maintain previous state/When oscillation stops*1, Hi-Z / Internal input fixed at "0"
C	INITX input pin	Pull-up / Input enabled	Pull-up / Input enabled	Pull-up / Input enabled	Pull-up / Input enabled	Pull-up / Input enabled	Pull-up / Input enabled	Pull-up / Input enabled	Pull-up / Input enabled	Pull-up / Input enabled
D	Mode input pin	Input enabled	Input enabled	Input enabled	Input enabled	Input enabled	Input enabled	Input enabled	Input enabled	Input enabled
E	Mode input pin	Input enabled	Input enabled	Input enabled	Input enabled	Input enabled	Input enabled	Input enabled	Input enabled	Input enabled
	GPIO selected	Setting disabled	Setting disabled	Setting disabled	Maintain previous state	Maintain previous state	Hi-Z / Input enabled	GPIO selected	Hi-Z / Input enabled	GPIO selected

MB9B320M Series

Pin status type	Function group	Power-on reset or low-voltage detection state	INITX input state	Device internal reset state	Run mode or SLEEP mode state	Timer mode, RTC mode, or STOP mode state		Deep standby RTC mode or Deep standby STOP mode state		Return from Deep standby mode state
		Power supply unstable	Power supply stable		Power supply stable	Power supply stable		Power supply stable		Power supply stable
		-	INITX = 0	INITX = 1	INITX = 1	INITX = 1		INITX = 1		INITX = 1
		-	-	-	-	SPL = 0	SPL = 1	SPL = 0	SPL = 1	-
F	GPIO selected	Setting disabled	Setting disabled	Setting disabled	Maintain previous state	Maintain previous state	Hi-Z / Internal input fixed at "0"	GPIO selected Internal input fixed at "0"	Hi-Z / Internal input fixed at "0"	GPIO selected
	Sub crystal oscillator input pin / External sub clock input selected	Input enabled	Input enabled	Input enabled	Input enabled	Input enabled	Input enabled	Input enabled	Input enabled	Input enabled
G	GPIO selected	Setting disabled	Setting disabled	Setting disabled	Maintain previous state	Maintain previous state	Hi-Z / Internal input fixed at "0"	GPIO selected Internal input fixed at "0"	Hi-Z / Internal input fixed at "0"	GPIO selected
	External sub clock input selected	Setting disabled	Setting disabled	Setting disabled	Maintain previous state	Maintain previous state	Hi-Z / Internal input fixed at "0"	Maintain previous state	Hi-Z / Internal input fixed at "0"	Maintain previous state
	Sub crystal oscillator output pin	Hi-Z / Internal input fixed at "0" / or Input enable	Hi-Z / Internal input fixed at "0"	Hi-Z / Internal input fixed at "0"	Maintain previous state	Maintain previous state / When oscillation stops* ² , Hi-Z / Internal input fixed at "0"	Maintain previous state / When oscillation stops* ² , Hi-Z / Internal input fixed at "0"	Maintain previous state / When oscillation stops* ² , Hi-Z / Internal input fixed at "0"	Maintain previous state / When oscillation stops* ² , Hi-Z / Internal input fixed at "0"	Maintain previous state / When oscillation stops* ² , Hi-Z / Internal input fixed at "0"
H	External interrupt enabled selected	Setting disabled	Setting disabled	Setting disabled	Maintain previous state	Maintain previous state	Maintain previous state	GPIO selected Internal input fixed at "0"	Hi-Z / Internal input fixed at "0"	GPIO selected
	GPIO selected	Hi-Z	Hi-Z / Input enabled	Hi-Z / Input enabled			Hi-Z / Internal input fixed at "0"			
	USB I/O pin	Setting disabled	Setting disabled	Setting disabled	Maintain previous state	Hi-Z at transmission / Input enabled / Internal input fixed at "0" at reception	Hi-Z at transmission / Input enabled / Internal input fixed at "0" at reception	Hi-Z / Input enabled	Hi-Z / Input enabled	Hi-Z / Input enabled

MB9B320M Series

Pin status type	Function group	Power-on reset or low-voltage detection state	INITX input state	Device internal reset state	Run mode or SLEEP mode state	Timer mode, RTC mode, or STOP mode state		Deep standby RTC mode or Deep standby STOP mode state		Return from Deep standby mode state	
		Power supply unstable	Power supply stable		Power supply stable	Power supply stable		Power supply stable		Power supply stable	
		-	INITX = 0	INITX = 1	INITX = 1	INITX = 1		INITX = 1		INITX = 1	
		-	-	-	-	SPL = 0	SPL = 1	SPL = 0	SPL = 1	-	
I	NMIX selected	Setting disabled	Setting disabled	Setting disabled	Maintain previous state	Maintain previous state	Maintain previous state	WKUP input enabled	Hi-Z / WKUP input enabled	GPIO selected	
	Resource other than above selected	Hi-Z	Hi-Z / Input enabled	Hi-Z / Input enabled			Hi-Z / Internal input fixed at "0"				Maintain previous state
	GPIO selected						Maintain previous state				
J	JTAG selected	Hi-Z	Pull-up / Input enabled	Pull-up / Input enabled	Maintain previous state	Maintain previous state	Maintain previous state	Maintain previous state	Maintain previous state	Maintain previous state	
	GPIO selected	Setting disabled	Setting disabled	Setting disabled			Hi-Z / Internal input fixed at "0"				GPIO selected Internal input fixed at "0"
K	Resource selected	Hi-Z	Hi-Z / Input enabled	Hi-Z / Input enabled	Maintain previous state	Maintain previous state	Hi-Z / Internal input fixed at "0"	GPIO selected Internal input fixed at "0"	Hi-Z / Internal input fixed at "0"	GPIO selected	
	GPIO selected						Hi-Z / Internal input fixed at "0"				
L	External interrupt enabled selected	Setting disabled	Setting disabled	Setting disabled	Maintain previous state	Maintain previous state	Maintain previous state	GPIO selected Internal input fixed at "0"	Hi-Z / Internal input fixed at "0"	GPIO selected	
	Resource other than above selected	Hi-Z	Hi-Z / Input enabled	Hi-Z / Input enabled			Hi-Z / Internal input fixed at "0"				
	GPIO selected						Hi-Z / Internal input fixed at "0"				
M	Analog input selected	Hi-Z	Hi-Z / Internal input fixed at "0" / Analog input enabled	Hi-Z / Internal input fixed at "0" / Analog input enabled	Hi-Z / Internal input fixed at "0" / Analog input enabled	Hi-Z / Internal input fixed at "0" / Analog input enabled	Hi-Z / Internal input fixed at "0" / Analog input enabled	Hi-Z / Internal input fixed at "0" / Analog input enabled	Hi-Z / Internal input fixed at "0" / Analog input enabled	Hi-Z / Internal input fixed at "0" / Analog input enabled	
	Resource other than above selected		Setting disabled	Setting disabled	Setting disabled	Maintain previous state	Maintain previous state	Hi-Z / Internal input fixed at "0"	GPIO selected Internal input fixed at "0"	Hi-Z / Internal input fixed at "0"	GPIO selected
	GPIO selected							Hi-Z / Internal input fixed at "0"			

MB9B320M Series

Pin status type	Function group	Power-on reset or low-voltage detection state	INITX input state	Device internal reset state	Run mode or SLEEP mode state	Timer mode, RTC mode, or STOP mode state		Deep standby RTC mode or Deep standby STOP mode state		Return from Deep standby mode state
		Power supply unstable	Power supply stable		Power supply stable	Power supply stable		Power supply stable		Power supply stable
		-	INITX = 0	INITX = 1	INITX = 1	INITX = 1		INITX = 1		INITX = 1
		-	-	-	-	SPL = 0	SPL = 1	SPL = 0	SPL = 1	-
N	Analog input selected	Hi-Z	Hi-Z / Internal input fixed at "0" / Analog input enabled	Hi-Z / Internal input fixed at "0" / Analog input enabled	Hi-Z / Internal input fixed at "0" / Analog input enabled	Hi-Z / Internal input fixed at "0" / Analog input enabled	Hi-Z / Internal input fixed at "0" / Analog input enabled	Hi-Z / Internal input fixed at "0" / Analog input enabled	Hi-Z / Internal input fixed at "0" / Analog input enabled	Hi-Z / Internal input fixed at "0" / Analog input enabled
	External interrupt enabled selected	Setting disabled	Setting disabled	Setting disabled	Maintain previous state	Maintain previous state	Maintain previous state	GPIO selected Internal input fixed at "0"	Hi-Z / Internal input fixed at "0"	GPIO selected
	Resource other than above selected						Hi-Z / Internal input fixed at "0"			
	GPIO selected									

*1 : Oscillation is stopped at Sub timer mode, sub CR timer mode, RTC mode, STOP mode, Deep standby RTC mode, and Deep standby STOP mode.

*2 : Oscillation is stopped at STOP mode and Deep standby STOP mode.

■ ELECTRICAL CHARACTERISTICS

1. Absolute Maximum Ratings

Parameter	Symbol	Rating		Unit	Remarks
		Min	Max		
Power supply voltage* ¹ , * ²	V _{CC}	V _{SS} - 0.5	V _{SS} + 6.5	V	
Power supply voltage (for USB)* ¹ , * ³	USBV _{CC}	V _{SS} - 0.5	V _{SS} + 6.5	V	
Analog power supply voltage* ¹ , * ⁴	AV _{CC}	V _{SS} - 0.5	V _{SS} + 6.5	V	
Analog reference voltage* ¹ , * ⁴	AVRH	V _{SS} - 0.5	V _{SS} + 6.5	V	
Input voltage* ¹	V _I	V _{SS} - 0.5	V _{CC} + 0.5 (≤ 6.5V)	V	Except for USB pin
		V _{SS} - 0.5	USBV _{CC} + 0.5 (≤ 6.5V)	V	USB pin
		V _{SS} - 0.5	V _{SS} + 6.5	V	5V tolerant
Analog pin input voltage* ¹	V _{IA}	V _{SS} - 0.5	AV _{CC} + 0.5 (≤ 6.5V)	V	
Output voltage* ¹	V _O	V _{SS} - 0.5	V _{CC} + 0.5 (≤ 6.5V)	V	
"L" level maximum output current* ⁵	I _{OL}	-	10	mA	4mA type
			20	mA	12mA type
			39	mA	The pin doubled as USB I/O
"L" level average output current* ⁶	I _{OLAV}	-	4	mA	4mA type
			12	mA	12mA type
			16.5	mA	The pin doubled as USB I/O
"L" level total maximum output current	∑I _{OL}	-	100	mA	
"L" level total average output current* ⁷	∑I _{OLAV}	-	50	mA	
"H" level maximum output current* ⁵	I _{OH}	-	- 10	mA	4mA type
			- 20	mA	12mA type
			- 39	mA	The pin doubled as USB I/O
"H" level average output current* ⁶	I _{OHAV}	-	- 4	mA	4mA type
			- 12	mA	12mA type
			- 18	mA	The pin doubled as USB I/O
"H" level total maximum output current	∑I _{OH}	-	- 100	mA	
"H" level total average output current* ⁷	∑I _{OHAV}	-	- 50	mA	
Power consumption	P _D	-	300	mW	
Storage temperature	T _{STG}	- 55	+ 150	°C	

*1 : These parameters are based on the condition that V_{SS} = AV_{SS} = 0V.

*2 : V_{CC} must not drop below V_{SS} - 0.5V.

*3 : USBV_{CC} must not drop below V_{SS} - 0.5V.

*4 : Ensure that the voltage does not exceed V_{CC} + 0.5 V, for example, when the power is turned on.

*5 : The maximum output current is defined as the value of the peak current flowing through any one of the corresponding pins.

*6 : The average output current is defined as the average current value flowing through any one of the corresponding pins for a 100 ms period.

*7 : The total average output current is defined as the average current value flowing through all of corresponding pins for a 100ms.

<WARNING>

Semiconductor devices can be permanently damaged by application of stress (voltage, current, temperature, etc.) in excess of absolute maximum ratings. Do not exceed these ratings.

2. Recommended Operating Conditions

($V_{SS} = AV_{SS} = AV_{RL} = 0.0V$)

Parameter	Symbol	Conditions	Value		Unit	Remarks
			Min	Max		
Power supply voltage	V_{CC}	-	2.7	5.5	V	
Power supply voltage (3V power supply) for USB	$USBV_{CC}$	-	3.0	3.6 ($\leq V_{CC}$)	V	*1
			2.7	5.5 ($\leq V_{CC}$)		*2
Analog power supply voltage	AV_{CC}	-	2.7	5.5	V	$AV_{CC} = V_{CC}$
Analog reference voltage	AV_{RH}	-	AV_{SS}	AV_{CC}	V	
Smoothing capacitor	C_S	-	1	10	μF	For Regulator*3
Operating temperature	T_a	-	- 40	+ 105	$^{\circ}C$	

*1: When P81/UDP0 and P80/UDM0 pins are used as USB (UDP0, UDM0).

*2: When P81/UDP0 and P80/UDM0 pins are used as GPIO (P81, P80).

*3: See "• C Pin" in "■HANDLING DEVICES" for the connection of the smoothing capacitor.

<WARNING>

The recommended operating conditions are required in order to ensure the normal operation of the semiconductor device. All of the device's electrical characteristics are warranted when the device is operated within these ranges.

Always use semiconductor devices within their recommended operating condition ranges. Operation outside these ranges may adversely affect reliability and could result in device failure. No warranty is made with respect to uses, operating conditions, or combinations not represented on the data sheet. Users considering application outside the listed conditions are advised to contact their representatives beforehand.

MB9B320M Series

3. DC Characteristics

(1) Current Rating

($V_{CC} = AV_{CC} = USBV_{CC} = 2.7V$ to $5.5V$, $V_{SS} = AV_{SS} = AVRL = 0V$, $T_a = -40^{\circ}C$ to $+105^{\circ}C$)

Parameter	Symbol	Pin name	Conditions	Value			Unit	Remarks
				Min	Typ	Max		
Power supply current	I_{CC}	VCC	Normal operation (PLL)	-	32.5	41	mA	CPU : 72MHz, Peripheral : 36MHz *1
				-	18	23	mA	CPU:72MHz, Peripheral: clock stops *1
			Normal operation (built-in high-speed CR)	-	2.5	3.4	mA	CPU/ Peripheral : 4MHz*2 *1
			Normal operation (sub oscillation)	-	110	980	μA	CPU/ Peripheral : 32kHz *1
			Normal operation (built-in low-speed CR)	-	130	1030	μA	CPU/ Peripheral : 100kHz *1
	I_{CCS}		SLEEP operation (PLL)	-	22	28	mA	Peripheral : 36MHz *1
			SLEEP operation (built-in high-speed CR)	-	1.6	2.6	mA	Peripheral : 4MHz*2 *1
			SLEEP operation (sub oscillation)	-	96	955	μA	Peripheral : 32kHz *1
			SLEEP operation (built-in low-speed CR)	-	115	975	μA	Peripheral : 100kHz *1
	I_{CCH}		STOP mode	-	14	53	μA	$T_a = +25^{\circ}C$, When LVD is off *1
				-	-	600	μA	$T_a = +105^{\circ}C$, When LVD is off *1
	I_{CCT}		TIMER mode (sub oscillation)	-	17	66	μA	$T_a = +25^{\circ}C$, When LVD is off *1
				-	-	835	μA	$T_a = +105^{\circ}C$, When LVD is off *1
	I_{CCR}		RTC mode (sub oscillation)	-	15	61	μA	$T_a = +25^{\circ}C$, When LVD is off *1
-		-		680	μA	$T_a = +105^{\circ}C$, When LVD is off *1		

MB9B320M Series

($V_{CC} = AV_{CC} = USBV_{CC} = 2.7V$ to $5.5V$, $V_{SS} = AV_{SS} = AV_{RL} = 0V$, $T_a = -40^{\circ}C$ to $+105^{\circ}C$)

Parameter	Symbol	Pin name	Conditions	Value			Unit	Remarks
				Min	Typ	Max		
Power supply current	I_{CCHD}	VCC	Deep Standby STOP mode	-	1.6	9.6	μA	$T_a = +25^{\circ}C$, When LVD is off, When RAM is off *1
				-	5.6	22	μA	$T_a = +25^{\circ}C$, When LVD is off, When RAM is on *1
				-	-	150	μA	$T_a = +105^{\circ}C$, When LVD is off, When RAM is off *1
				-	-	210	μA	$T_a = +105^{\circ}C$, When LVD is off, When RAM is on *1
	I_{CCRD}		Deep Standby RTC mode (sub oscillation)	-	2.2	11	μA	$T_a = +25^{\circ}C$, When LVD is off, When RAM is off *1
				-	6.2	23	μA	$T_a = +25^{\circ}C$, When LVD is off, When RAM is on *1
				-	-	155	μA	$T_a = +105^{\circ}C$, When LVD is off, When RAM is off *1
				-	-	215	μA	$T_a = +105^{\circ}C$, When LVD is off, When RAM is on *1
Low-voltage detection circuit (LVD) power supply current	I_{CCLVD}	At operation	-	0.13	0.3	μA	For occurrence of reset	
			-	0.13	0.3	μA	For occurrence of interrupt	
Flash memory write/erase current	$I_{CCFLASH}$	At Write/Erase	-	9.5	11.2	mA		

*1: When all ports are fixed.

*2: When setting it to 4MHz by trimming.

MB9B320M Series

(2) Pin Characteristics

($V_{CC} = USBV_{CC} = AV_{CC} = 2.7V$ to $5.5V$, $V_{SS} = AV_{SS} = AVR_L = 0V$, $T_a = -40^{\circ}C$ to $+105^{\circ}C$)

Parameter	Symbol	Pin name	Conditions	Value			Unit	Remarks		
				Min	Typ	Max				
"H" level input voltage (hysteresis input)	V_{IHS}	CMOS hysteresis input pin, MD0, MD1	-	$V_{CC} \times 0.8$	-	$V_{CC} + 0.3$	V			
		5V tolerant input pin	-	$V_{CC} \times 0.8$	-	$V_{SS} + 5.5$	V			
"L" level input voltage (hysteresis input)	V_{ILS}	CMOS hysteresis input pin, MD0, MD1	-	$V_{SS} - 0.3$	-	$V_{CC} \times 0.2$	V			
		5V tolerant input pin	-	$V_{SS} - 0.3$	-	$V_{CC} \times 0.2$	V			
"H" level output voltage	V_{OH}	4mA type	$V_{CC} \geq 4.5V$, $I_{OH} = -4mA$	$V_{CC} - 0.5$	-	V_{CC}	V			
			$V_{CC} < 4.5V$, $I_{OH} = -2mA$							
		12mA type	$V_{CC} \geq 4.5V$, $I_{OH} = -12mA$	$V_{CC} - 0.5$	-	V_{CC}	V			
$V_{CC} < 4.5V$, $I_{OH} = -8mA$										
		The pin doubled as USB I/O	$USBV_{CC} \geq 4.5V$, $I_{OH} = -18.0mA$ $USBV_{CC} < 4.5V$, $I_{OH} = -12.0mA$	$USBV_{CC} - 0.4$	-	$USBV_{CC}$	V			
"L" level output voltage	V_{OL}	4mA type	$V_{CC} \geq 4.5V$, $I_{OL} = 4mA$	V_{SS}	-	0.4	V			
			$V_{CC} < 4.5V$, $I_{OL} = 2mA$							
		12mA type	$V_{CC} \geq 4.5V$, $I_{OL} = 12mA$	V_{SS}	-	0.4	V			
			$V_{CC} < 4.5V$, $I_{OL} = 8mA$							
				The pin doubled as USB I/O	$USBV_{CC} \geq 4.5V$, $I_{OL} = 16.5mA$ $USBV_{CC} < 4.5V$, $I_{OL} = 10.5mA$	V_{SS}	-	0.4	V	
Input leak current	I_{IL}	-	-	-5	-	+5	μA			
Pull-up resistance value	R_{PU}	Pull-up pin	$V_{CC} \geq 4.5V$	33	50	90	k Ω			
			$V_{CC} < 4.5V$	-	-	180				
Input capacitance	C_{IN}	Other than VCC, USBVCC, VSS, AVCC, AVSS, AVR_H, AVR_L	-	-	5	15	pF			

4. AC Characteristics

(1) Main Clock Input Characteristics

($V_{CC} = 2.7V$ to $5.5V$, $V_{SS} = 0V$, $T_a = -40^{\circ}C$ to $+105^{\circ}C$)

Parameter	Symbol	Pin name	Conditions	Value		Unit	Remarks	
				Min	Max			
Input frequency	F_{CH}	X0, X1	$V_{CC} \geq 4.5V$	4	48	MHz	When crystal oscillator is connected	
			$V_{CC} < 4.5V$	4	20			
			$V_{CC} \geq 4.5V$	4	48	MHz		
			$V_{CC} < 4.5V$	4	20			
Input clock cycle	t_{CYLH}		$V_{CC} \geq 4.5V$	20.83	250	ns	When using external Clock	
			$V_{CC} < 4.5V$	50	250			
Input clock pulse width	-			P_{WH}/t_{CYLH} , P_{WL}/t_{CYLH}	45	55	%	When using external Clock
Input clock rising time and falling time	t_{CF} , t_{CR}			-	-	5	ns	When using external Clock
Internal operating clock frequency ^{*1}	F_{CM}	-	-	-	72	MHz	Master clock	
	F_{CC}	-	-	-	72	MHz	Base clock (HCLK/FCLK)	
	F_{CP0}	-	-	-	40	MHz	APB0 bus clock ^{*2}	
	F_{CP1}	-	-	-	40	MHz	APB1 bus clock ^{*2}	
	F_{CP2}	-	-	-	40	MHz	APB2 bus clock ^{*2}	
Internal operating clock cycle time ^{*1}	t_{CYCC}	-	-	13.8	-	ns	Base clock (HCLK/FCLK)	
	t_{CYCP0}	-	-	25	-	ns	APB0 bus clock ^{*2}	
	t_{CYCP1}	-	-	25	-	ns	APB1 bus clock ^{*2}	
	t_{CYCP2}	-	-	25	-	ns	APB2 bus clock ^{*2}	

*1: For more information about each internal operating clock, see "Chapter:Clock" in "FM3 Family PERIPHERAL MANUAL".

*2: For about each APB bus which each peripheral is connected to, see "■ BLOCK DIAGRAM" in this data sheet.

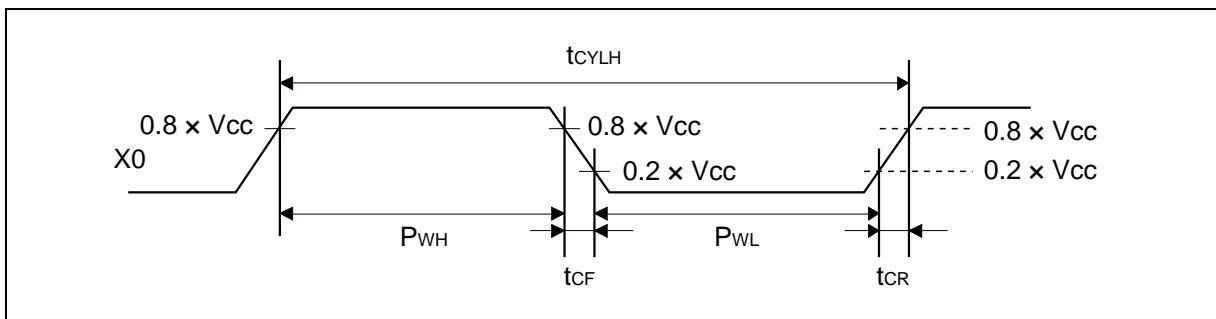

MB9B320M Series

(2) Sub Clock Input Characteristics

($V_{CC} = 2.7V$ to $5.5V$, $V_{SS} = 0V$, $T_a = -40^{\circ}C$ to $+105^{\circ}C$)

Parameter	Symbol	Pin name	Conditions	Value			Unit	Remarks
				Min	Typ	Max		
Input frequency	$1/t_{CYLL}$	X0A, X1A	-	-	32.768	-	kHz	When crystal oscillator is connected
			-	32	-	100		kHz
Input clock cycle	t_{CYLL}		-	10	-	31.25	μs	When using external clock
Input clock pulse width	-		P_{WH}/t_{CYLL} , P_{WL}/t_{CYLL}	45	-	55	%	When using external clock

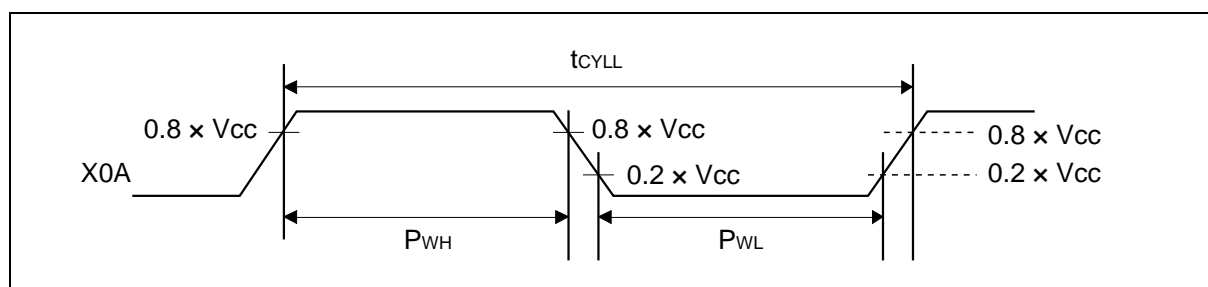

(3) Built-in CR Oscillation Characteristics

- Built-in High-speed CR

($V_{CC} = 2.7V$ to $5.5V$, $V_{SS} = 0V$, $T_a = -40^{\circ}C$ to $+105^{\circ}C$)

Parameter	Symbol	Conditions	Value			Unit	Remarks
			Min	Typ	Max		
Clock frequency	F_{CRH}	$T_a = +25^{\circ}C$	3.92	4	4.08	MHz	When trimming*
		$T_a = 0^{\circ}C$ to $+85^{\circ}C$	3.9	4	4.1		
		$T_a = -40^{\circ}C$ to $+105^{\circ}C$	3.88	4	4.12		
		$T_a = +25^{\circ}C$ $V_{CC} \leq 3.6V$	3.94	4	4.06		
		$T_a = -20^{\circ}C$ to $+85^{\circ}C$ $V_{CC} \leq 3.6V$	3.92	4	4.08		
		$T_a = -20^{\circ}C$ to $+105^{\circ}C$ $V_{CC} \leq 3.6V$	3.9	4	4.1		
		$T_a = -40^{\circ}C$ to $+105^{\circ}C$	2.8	4	5.2	When not trimming	

*: In the case of using the values in CR trimming area of Flash memory at shipment for frequency/temperature trimming.

- Built-in Low-speed CR

($V_{CC} = 2.7V$ to $5.5V$, $V_{SS} = 0V$, $T_a = -40^{\circ}C$ to $+105^{\circ}C$)

Parameter	Symbol	Conditions	Value			Unit	Remarks
			Min	Typ	Max		
Clock frequency	F_{CRL}	-	50	100	150	kHz	

(4-1) Operating Conditions of Main and USB PLL (In the case of using main clock for input of PLL)
($V_{CC} = 2.7V$ to $5.5V$, $V_{SS} = 0V$, $T_a = -40^{\circ}C$ to $+105^{\circ}C$)

Parameter	Symbol	Value			Unit	Remarks
		Min	Typ	Max		
PLL oscillation stabilization wait time* ¹ (LOCK UP time)	t_{LOCK}	100	-	-	μs	
PLL input clock frequency	F_{PLL}	4	-	16	MHz	
PLL multiplication rate	-	5	-	37	multiplier	
PLL macro oscillation clock frequency	F_{PLLO}	75	-	150	MHz	
Main PLL clock frequency* ²	F_{CLKPLL}	-	-	72	MHz	
USB clock frequency* ³	$F_{CLKSPLL}$	-	-	48	MHz	After the M frequency division

*1: Time from when the PLL starts operating until the oscillation stabilizes.

*2: For more information about Main PLL clock (CLKPLL), see "Chapter: Clock" in "FM3 Family PERIPHERAL MANUAL".

*3: For more information about USB clock, see "Chapter: USB Clock Generation" in "FM3 Family PERIPHERAL MANUAL Communication Macro Part".

(4-2) Operating Conditions of Main PLL (In the case of using built-in high-speed CR for input clock of main PLL)

($V_{CC} = 2.7V$ to $5.5V$, $V_{SS} = 0V$, $T_a = -40^{\circ}C$ to $+105^{\circ}C$)

Parameter	Symbol	Value			Unit	Remarks
		Min	Typ	Max		
PLL oscillation stabilization wait time* ¹ (LOCK UP time)	t_{LOCK}	100	-	-	μs	
PLL input clock frequency	F_{PLL}	3.8	4	4.2	MHz	
PLL multiplication rate	-	19	-	35	multiplier	
PLL macro oscillation clock frequency	F_{PLLO}	72	-	150	MHz	
Main PLL clock frequency* ²	F_{CLKPLL}	-	-	72	MHz	

*1: Time from when the PLL starts operating until the oscillation stabilizes.

*2: For more information about Main PLL clock (CLKPLL), see "Chapter: Clock" in "FM3 Family PERIPHERAL MANUAL".

Note: Make sure to input to the main PLL source clock, the high-speed CR clock (CLKHC) that the frequency has been trimmed.

MB9B320M Series

(5) Reset Input Characteristics

($V_{CC} = 2.7V$ to $5.5V$, $V_{SS} = 0V$, $T_a = -40^{\circ}C$ to $+105^{\circ}C$)

Parameter	Symbol	Pin name	Conditions	Value		Unit	Remarks
				Min	Max		
Reset input time	t_{INITX}	INITX	-	500	-	ns	

(6) Power-on Reset Timing

($V_{CC} = 2.7V$ to $5.5V$, $V_{SS} = 0V$, $T_a = -40^{\circ}C$ to $+105^{\circ}C$)

Parameter	Symbol	Pin name	Value		Unit	Remarks
			Min	Max		
Power supply rising time	T_r	VCC	0	-	ms	
Power supply shut down time	T_{off}		1	-	ms	

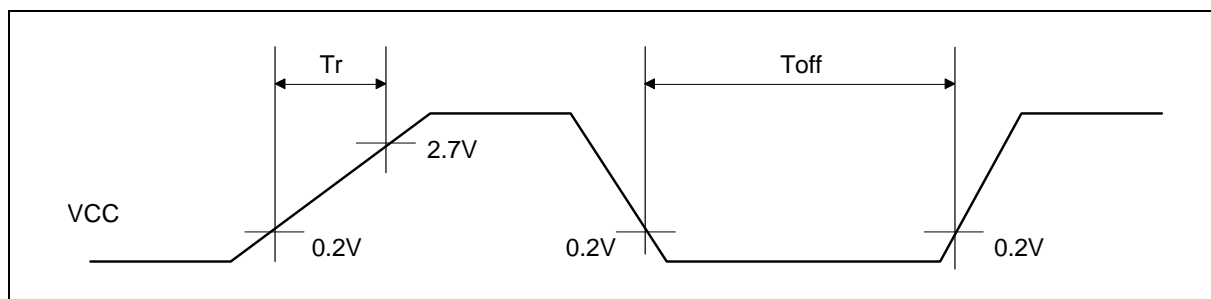

(7) Base Timer Input Timing

- Timer input timing

($V_{CC} = 2.7V$ to $5.5V$, $V_{SS} = 0V$, $T_a = -40^{\circ}C$ to $+105^{\circ}C$)

Parameter	Symbol	Pin name	Conditions	Value		Unit	Remarks
				Min	Max		
Input pulse width	t_{TIWH} , t_{TIWL}	TIOAn/TIOBn (when using as ECK, TIN)	-	$2t_{CYCP}$	-	ns	

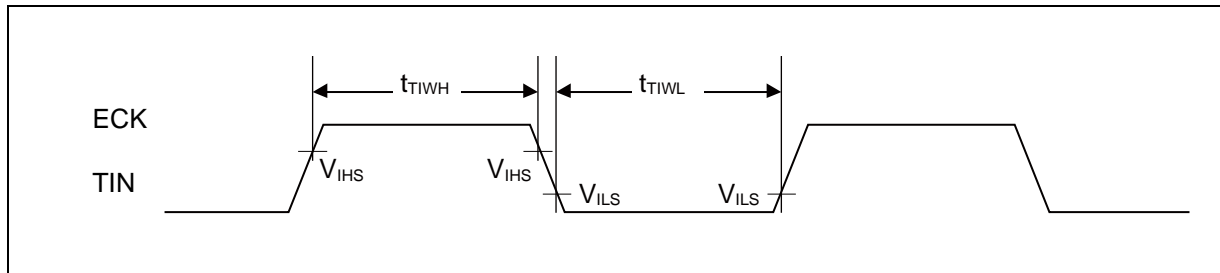

- Trigger input timing

($V_{CC} = 2.7V$ to $5.5V$, $V_{SS} = 0V$, $T_a = -40^{\circ}C$ to $+105^{\circ}C$)

Parameter	Symbol	Pin name	Conditions	Value		Unit	Remarks
				Min	Max		
Input pulse width	t_{TRGH} , t_{TRGL}	TIOAn/TIOBn (when using as TGIN)	-	$2t_{CYCP}$	-	ns	

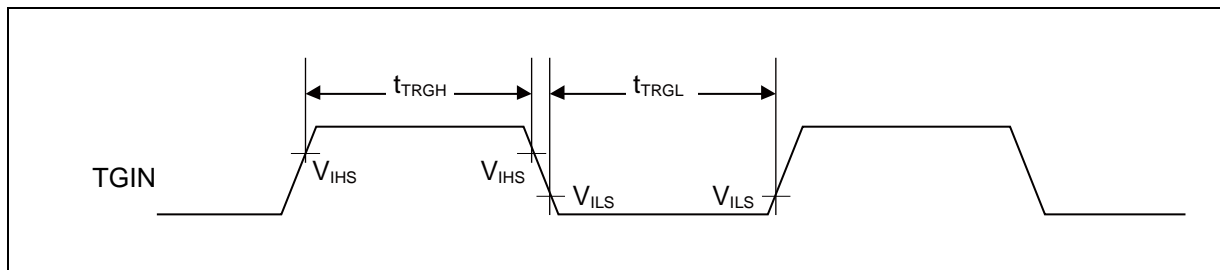

Note: t_{CYCP} indicates the APB bus clock cycle time.

About the APB bus number which the Base Timer is connected to, see "■BLOCK DIAGRAM" in this data sheet.

MB9B320M Series

(8) UART Timing

- Synchronous serial (SPI = 0, SCINV = 0)

($V_{CC} = 2.7V$ to $5.5V$, $V_{SS} = 0V$, $T_a = -40^{\circ}C$ to $+105^{\circ}C$)

Parameter	Symbol	Pin name	Conditions	$V_{CC} < 4.5V$		$V_{CC} \geq 4.5V$		Unit
				Min	Max	Min	Max	
Serial clock cycle time	t_{SCYC}	SCK _X	Internal shift clock operation	$4t_{CYCP}$	-	$4t_{CYCP}$	-	ns
SCK ↓ → SOT delay time	t_{SLOVI}	SCK _X , SOT _X		- 30	+ 30	- 20	+ 20	ns
SIN → SCK ↑ setup time	t_{VSHI}	SCK _X , SIN _X		50	-	30	-	ns
SCK ↑ → SIN hold time	t_{SHIXI}	SCK _X , SIN _X		0	-	0	-	ns
Serial clock "L" pulse width	t_{SLSH}	SCK _X	External shift clock operation	$2t_{CYCP} - 10$	-	$2t_{CYCP} - 10$	-	ns
Serial clock "H" pulse width	t_{SHSL}	SCK _X		$t_{CYCP} + 10$	-	$t_{CYCP} + 10$	-	ns
SCK ↓ → SOT delay time	t_{SLOVE}	SCK _X , SOT _X		-	50	-	30	ns
SIN → SCK ↑ setup time	t_{VSHI}	SCK _X , SIN _X		10	-	10	-	ns
SCK ↑ → SIN hold time	t_{SHIXE}	SCK _X , SIN _X		20	-	20	-	ns
SCK falling time	tF	SCK _X		-	5	-	5	ns
SCK rising time	tR	SCK _X		-	5	-	5	ns

- Notes:
- The above characteristics apply to CLK synchronous mode.
 - t_{CYCP} indicates the APB bus clock cycle time.
About the APB bus number which UART is connected to, see "■BLOCK DIAGRAM" in this data sheet.
 - These characteristics only guarantee the same relocate port number.
For example, the combination of SCLK_{X_0} and SOT_{X_1} is not guaranteed.
 - When the external load capacitance $C_L = 30pF$.

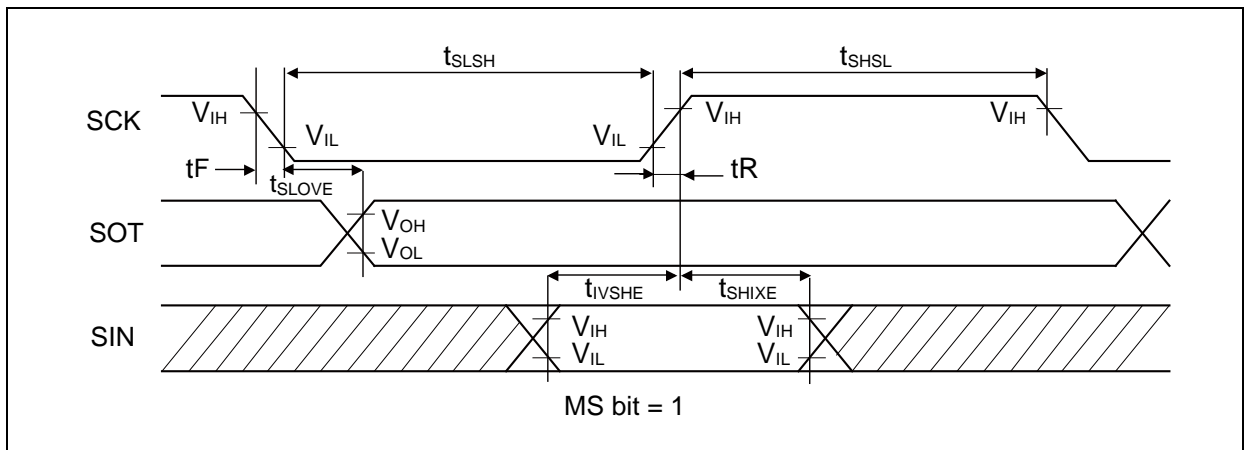
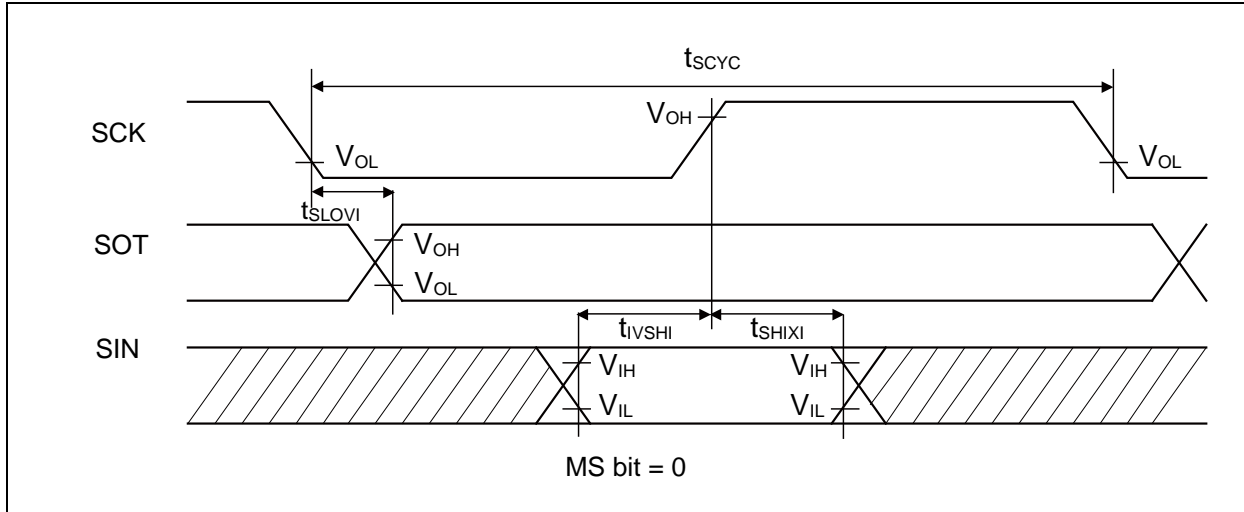

MB9B320M Series

- Synchronous serial (SPI = 0, SCINV = 1)

($V_{CC} = 2.7V$ to $5.5V$, $V_{SS} = 0V$, $T_a = -40^{\circ}C$ to $+105^{\circ}C$)

Parameter	Symbol	Pin name	Conditions	$V_{CC} < 4.5V$		$V_{CC} \geq 4.5V$		Unit
				Min	Max	Min	Max	
Serial clock cycle time	t_{SCYC}	SCK _X	Internal shift clock operation	$4t_{CYCP}$	-	$4t_{CYCP}$	-	ns
SCK ↑ → SOT delay time	t_{SHOVI}	SCK _X , SOT _X		- 30	+ 30	- 20	+ 20	ns
SIN → SCK ↓ setup time	t_{IVSLI}	SCK _X , SIN _X		50	-	30	-	ns
SCK ↓ → SIN hold time	t_{SLIXI}	SCK _X , SIN _X		0	-	0	-	ns
Serial clock "L" pulse width	t_{SLSH}	SCK _X	External shift clock operation	$2t_{CYCP} - 10$	-	$2t_{CYCP} - 10$	-	ns
Serial clock "H" pulse width	t_{SHSL}	SCK _X		$t_{CYCP} + 10$	-	$t_{CYCP} + 10$	-	ns
SCK ↑ → SOT delay time	t_{SHOVE}	SCK _X , SOT _X		-	50	-	30	ns
SIN → SCK ↓ setup time	t_{IVSLE}	SCK _X , SIN _X		10	-	10	-	ns
SCK ↓ → SIN hold time	t_{SLIXE}	SCK _X , SIN _X		20	-	20	-	ns
SCK falling time	t_F	SCK _X		-	5	-	5	ns
SCK rising time	t_R	SCK _X		-	5	-	5	ns

- Notes:
- The above characteristics apply to CLK synchronous mode.
 - t_{CYCP} indicates the APB bus clock cycle time.
 - About the APB bus number which UART is connected to, see "■BLOCK DIAGRAM" in this data sheet.
 - These characteristics only guarantee the same relocate port number.
For example, the combination of SCLK_X_0 and SOT_X_1 is not guaranteed.
 - When the external load capacitance $C_L = 30pF$.

MB9B320M Series

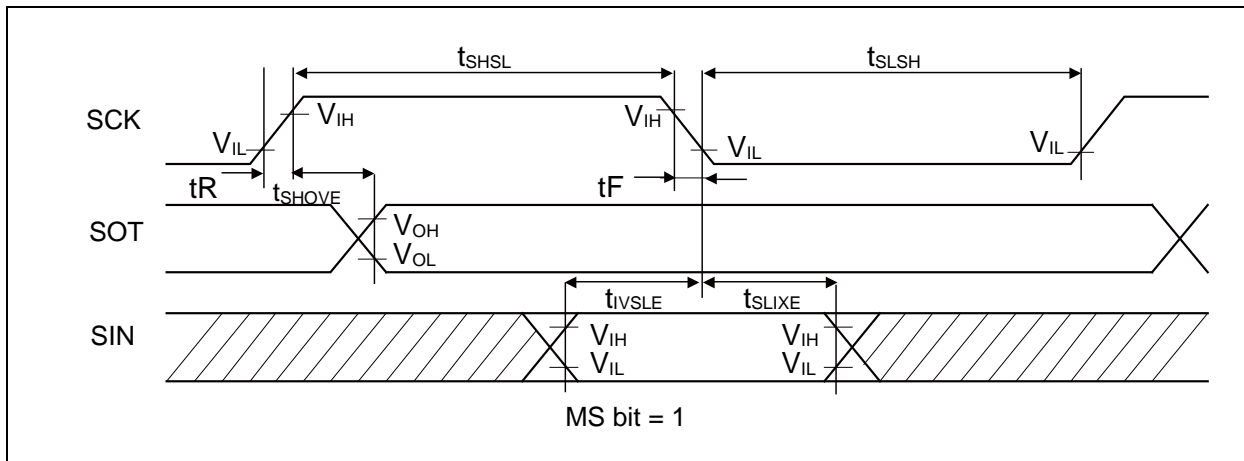
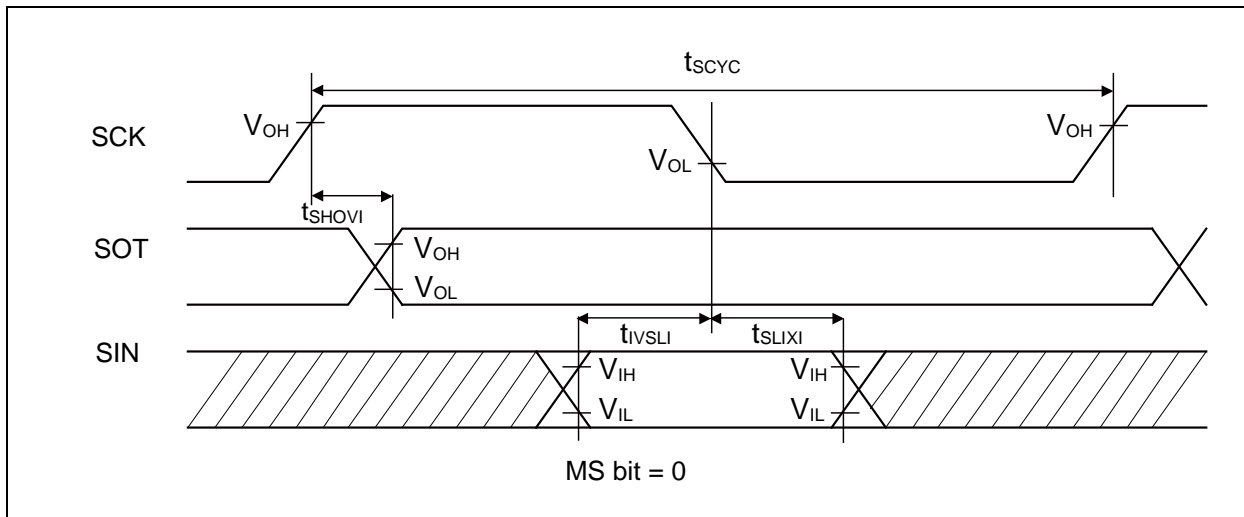

MB9B320M Series

- Synchronous serial (SPI = 1, SCINV = 0)

($V_{CC} = 2.7V$ to $5.5V$, $V_{SS} = 0V$, $T_a = -40^{\circ}C$ to $+105^{\circ}C$)

Parameter	Symbol	Pin name	Conditions	$V_{CC} < 4.5V$		$V_{CC} \geq 4.5V$		Unit
				Min	Max	Min	Max	
Serial clock cycle time	t_{SCYC}	SCK _X	Internal shift clock operation	$4t_{CYCP}$	-	$4t_{CYCP}$	-	ns
SCK ↑ → SOT delay time	t_{SHOVI}	SCK _X , SOT _X		- 30	+ 30	- 20	+ 20	ns
SIN → SCK ↓ setup time	t_{IVSLI}	SCK _X , SIN _X		50	-	30	-	ns
SCK ↓ → SIN hold time	t_{SLIXI}	SCK _X , SIN _X		0	-	0	-	ns
SOT → SCK ↓ delay time	t_{SOVLI}	SCK _X , SOT _X		$2t_{CYCP} - 30$	-	$2t_{CYCP} - 30$	-	ns
Serial clock "L" pulse width	t_{SLSH}	SCK _X		$2t_{CYCP} - 10$	-	$2t_{CYCP} - 10$	-	ns
Serial clock "H" pulse width	t_{SHSL}	SCK _X	$t_{CYCP} + 10$	-	$t_{CYCP} + 10$	-	ns	
SCK ↑ → SOT delay time	t_{SHOVE}	SCK _X , SOT _X	External shift clock operation	-	50	-	30	ns
SIN → SCK ↓ setup time	t_{IVSLE}	SCK _X , SIN _X		10	-	10	-	ns
SCK ↓ → SIN hold time	t_{SLIXE}	SCK _X , SIN _X		20	-	20	-	ns
SCK falling time	t_F	SCK _X		-	5	-	5	ns
SCK rising time	t_R	SCK _X		-	5	-	5	ns

- Notes:
- The above characteristics apply to CLK synchronous mode.
 - t_{CYCP} indicates the APB bus clock cycle time.
 - About the APB bus number which UART is connected to, see "■BLOCK DIAGRAM" in this data sheet.
 - These characteristics only guarantee the same relocate port number.
For example, the combination of SCLK_X_0 and SOT_X_1 is not guaranteed.
 - When the external load capacitance $C_L = 30pF$.

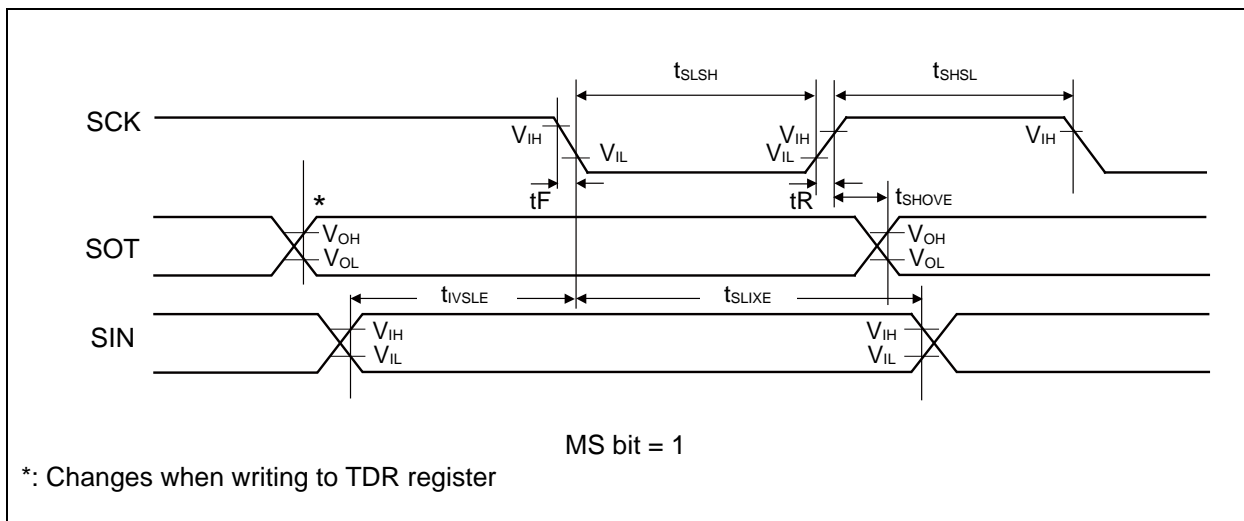
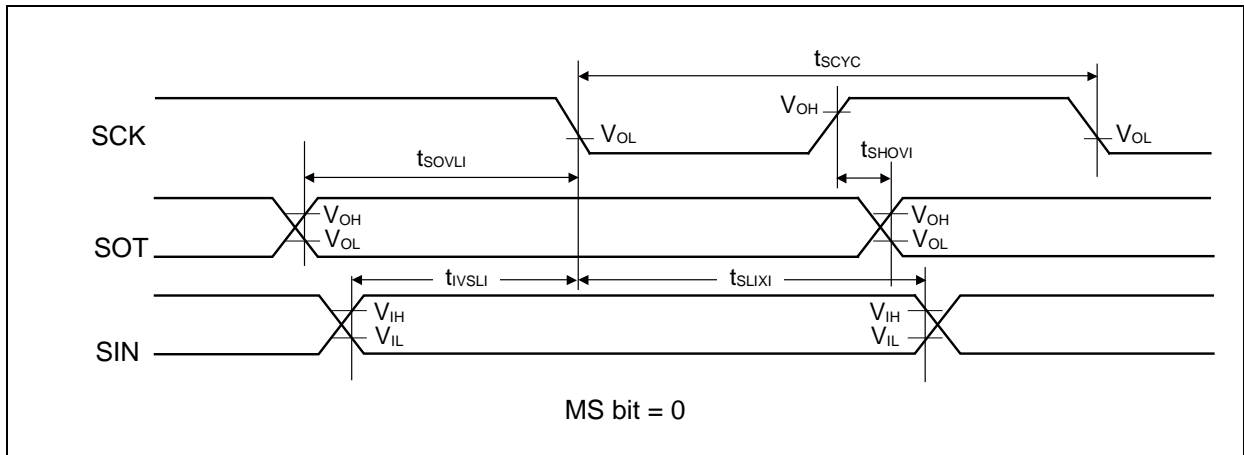

MB9B320M Series

- Synchronous serial (SPI = 1, SCINV = 1)

($V_{CC} = 2.7V$ to $5.5V$, $V_{SS} = 0V$, $T_a = -40^{\circ}C$ to $+105^{\circ}C$)

Parameter	Symbol	Pin name	Conditions	$V_{CC} < 4.5V$		$V_{CC} \geq 4.5V$		Unit
				Min	Max	Min	Max	
Serial clock cycle time	t_{SCYC}	SCK _X	Internal shift clock operation	$4t_{CYCP}$	-	$4t_{CYCP}$	-	ns
SCK ↓ → SOT delay time	t_{SLOVI}	SCK _X , SOT _X		- 30	+ 30	- 20	+ 20	ns
SIN → SCK ↑ setup time	t_{VSHI}	SCK _X , SIN _X		50	-	30	-	ns
SCK ↑ → SIN hold time	t_{SHIXI}	SCK _X , SIN _X		0	-	0	-	ns
SOT → SCK ↑ delay time	t_{SOVHI}	SCK _X , SOT _X		$2t_{CYCP} - 30$	-	$2t_{CYCP} - 30$	-	ns
Serial clock "L" pulse width	t_{SLSH}	SCK _X		$2t_{CYCP} - 10$	-	$2t_{CYCP} - 10$	-	ns
Serial clock "H" pulse width	t_{SHSL}	SCK _X	$t_{CYCP} + 10$	-	$t_{CYCP} + 10$	-	ns	
SCK ↓ → SOT delay time	t_{SLOVE}	SCK _X , SOT _X	External shift clock operation	-	50	-	30	ns
SIN → SCK ↑ setup time	t_{VSHI}	SCK _X , SIN _X		10	-	10	-	ns
SCK ↑ → SIN hold time	t_{SHIXE}	SCK _X , SIN _X		20	-	20	-	ns
SCK falling time	tF	SCK _X		-	5	-	5	ns
SCK rising time	tR	SCK _X		-	5	-	5	ns

- Notes:
- The above characteristics apply to CLK synchronous mode.
 - t_{CYCP} indicates the APB bus clock cycle time.
 - About the APB bus number which UART is connected to, see "■BLOCK DIAGRAM" in this data sheet.
 - These characteristics only guarantee the same relocate port number.
For example, the combination of SCLK_{X_0} and SOT_{X_1} is not guaranteed.
 - When the external load capacitance $C_L = 30pF$.

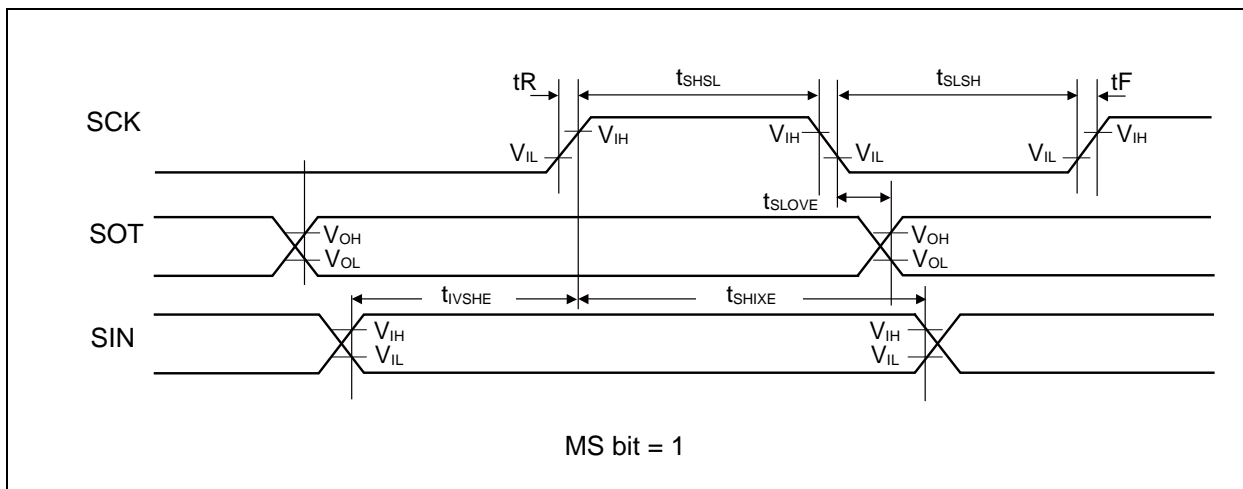
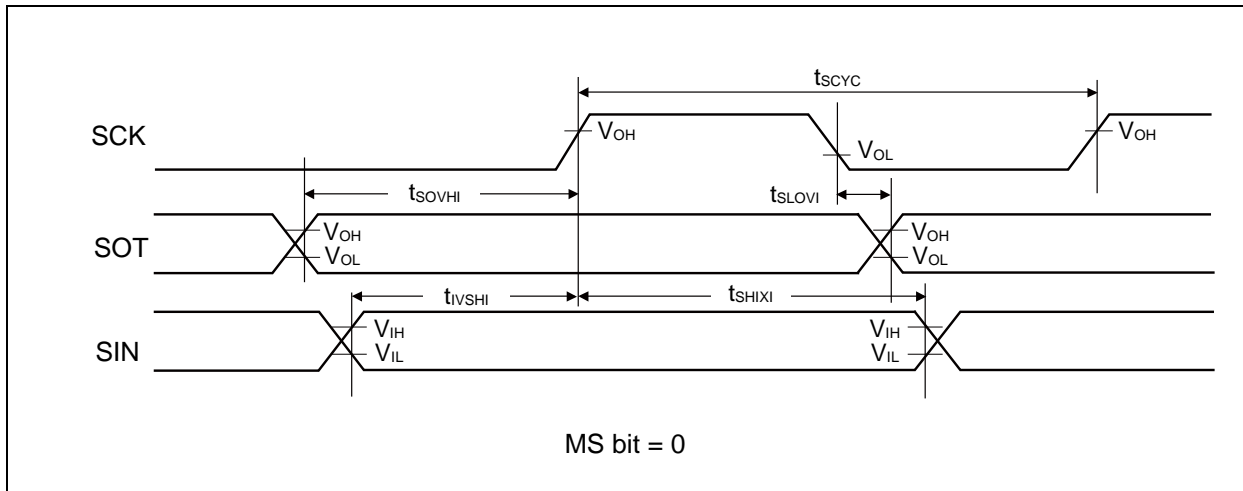

- External clock (EXT = 1) : asynchronous only

($V_{CC} = 2.7V$ to $5.5V$, $V_{SS} = 0V$, $T_a = -40^{\circ}C$ to $+105^{\circ}C$)

Parameter	Symbol	Conditions	Min	Max	Unit	Remarks
Serial clock "L" pulse width	t_{SLSH}	$C_L = 30pF$	$t_{CYCP} + 10$	-	ns	
Serial clock "H" pulse width	t_{SHSL}		$t_{CYCP} + 10$	-	ns	
SCK falling time	t_F		-	5	ns	
SCK rising time	t_R		-	5	ns	

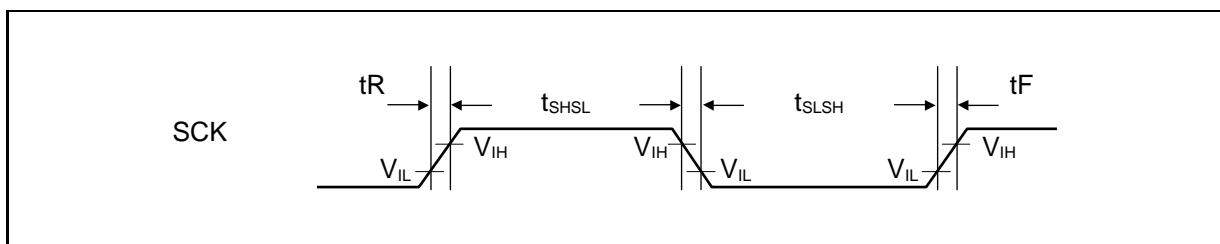

MB9B320M Series

(9) External Input Timing

($V_{CC} = 2.7V$ to $5.5V$, $V_{SS} = 0V$, $T_a = -40^{\circ}C$ to $+105^{\circ}C$)

Parameter	Symbol	Pin name	Conditions	Value		Unit	Remarks
				Min	Max		
Input pulse width	t_{INH} , t_{INL}	ADTG	-	$2t_{CYCP}^{*1}$	-	ns	A/D converter trigger input
		FRCKx					Free-run timer input clock
		ICxx	-	$2t_{CYCP}^{*1}$	-	ns	Input capture
		DTTIXX					Waveform generator
		INT00 to INT23, NMIX					$2t_{CYCP} + 100^{*1}$
			500^{*2}	-	ns	NMI	

*1 : t_{CYCP} indicates the APB bus clock cycle time except stop when in stop mode, in timer mode.

About the APB bus number which the A/D converter, Multi-function Timer, External interrupt are connected to, see "■BLOCK DIAGRAM" in this data sheet.

*2 : When in stop mode, in timer mode.

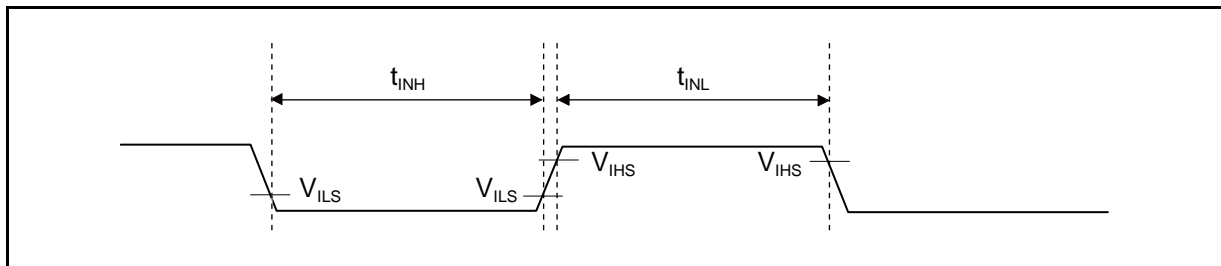

(10) Quadrature Position/Revolution Counter timing

($V_{CC} = 2.7V$ to $5.5V$, $V_{SS} = 0V$, $T_a = -40^{\circ}C$ to $+105^{\circ}C$)

Parameter	Symbol	Conditions	Value		Unit
			Min	Max	
AIN pin "H" width	t_{AHL}	-	$2t_{CYCP}^*$	-	ns
AIN pin "L" width	t_{ALL}	-			
BIN pin "H" width	t_{BHL}	-			
BIN pin "L" width	t_{BLL}	-			
BIN rising time from AIN pin "H" level	t_{AUBU}	PC_Mode2 or PC_Mode3			
AIN falling time from BIN pin "H" level	t_{BUAD}	PC_Mode2 or PC_Mode3			
BIN falling time from AIN pin "L" level	t_{ADBD}	PC_Mode2 or PC_Mode3			
AIN rising time from BIN pin "L" level	t_{BDAU}	PC_Mode2 or PC_Mode3			
AIN rising time from BIN pin "H" level	t_{BUAU}	PC_Mode2 or PC_Mode3			
BIN falling time from AIN pin "H" level	t_{AUBD}	PC_Mode2 or PC_Mode3			
AIN falling time from BIN pin "L" level	t_{BDAD}	PC_Mode2 or PC_Mode3			
BIN rising time from AIN pin "L" level	t_{ADBU}	PC_Mode2 or PC_Mode3			
ZIN pin "H" width	t_{ZHL}	QCR:CGSC="0"			
ZIN pin "L" width	t_{ZLL}	QCR:CGSC="0"			
AIN/BIN rising and falling time from determined ZIN level	t_{ZABE}	QCR:CGSC="1"			
Determined ZIN level from AIN/BIN rising and falling time	t_{ABEZ}	QCR:CGSC="1"			

*: t_{CYCP} indicates the APB bus clock cycle time except stop when in stop mode, in timer mode.

About the APB bus number which the Quadrature Position/Revolution Counter is connected to, see "BLOCK DIAGRAM" in this data sheet.

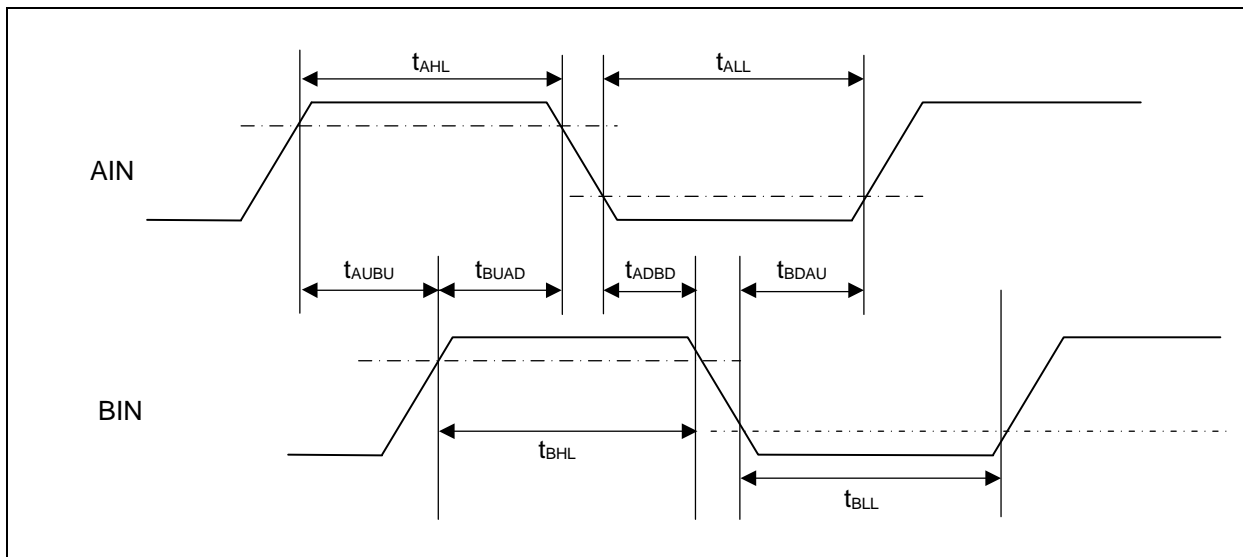

MB9B320M Series

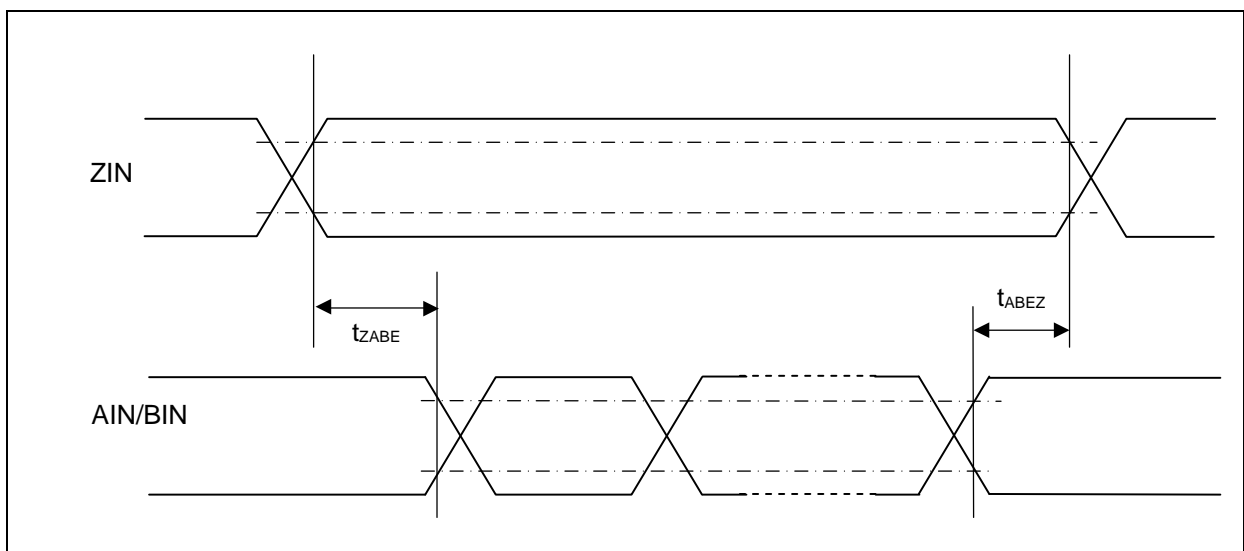
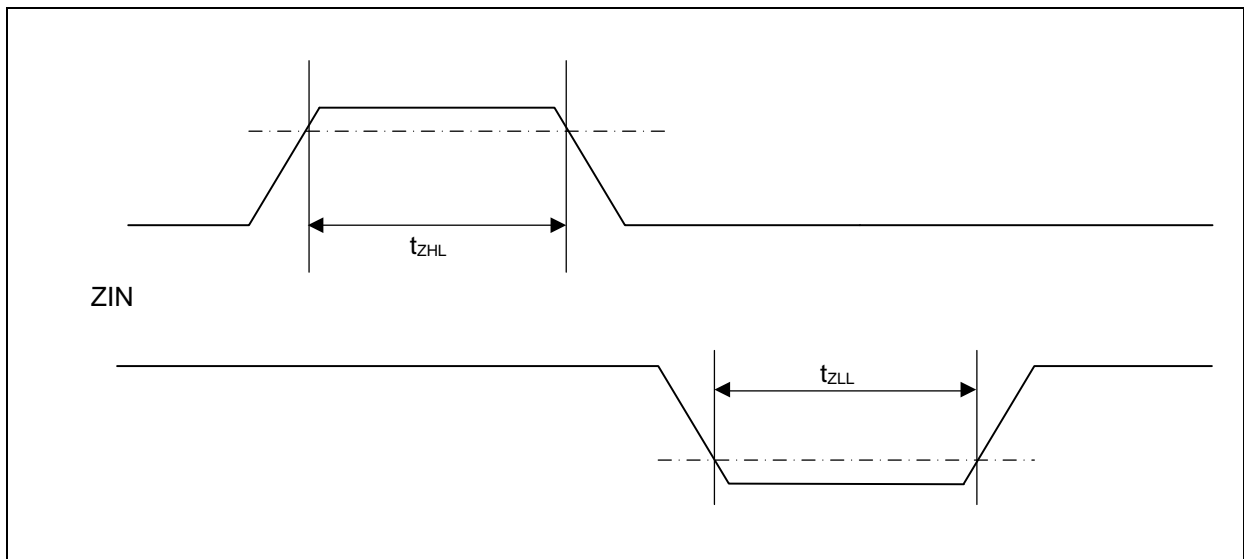
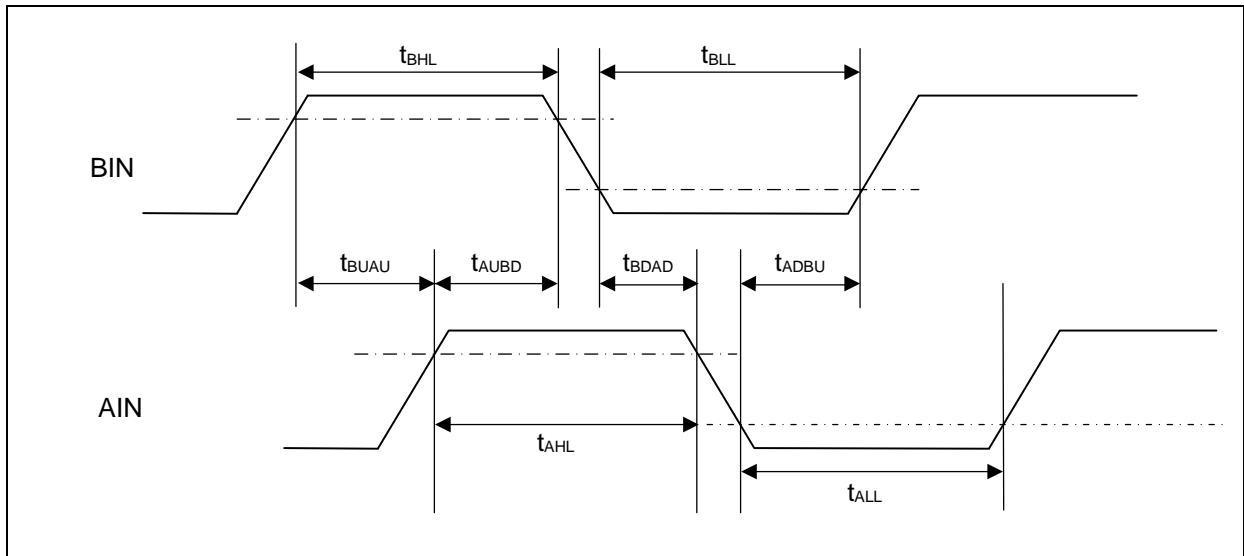

(11) I²C Timing

(V_{CC} = 2.7V to 5.5V, V_{SS} = 0V, Ta = - 40°C to + 105°C)

Parameter	Symbol	Conditions	Typical mode		High-speed mode		Unit	Remarks
			Min	Max	Min	Max		
SCL clock frequency	F _{SCL}		0	100	0	400	kHz	
(Repeated) START condition hold time SDA ↓ → SCL ↓	t _{HDSTA}	C _L = 30pF, R = (V _p /I _{OL})* ¹	4.0	-	0.6	-	μs	
SCLclock "L" width	t _{LOW}		4.7	-	1.3	-	μs	
SCLclock "H" width	t _{HIGH}		4.0	-	0.6	-	μs	
(Repeated) START condition setup time SCL ↑ → SDA ↓	t _{SUSTA}		4.7	-	0.6	-	μs	
Data hold time SCL ↓ → SDA ↓ ↑	t _{HDDAT}		0	3.45* ²	0	0.9* ³	μs	
Data setup time SDA ↓ ↑ → SCL ↑	t _{SUDAT}		250	-	100	-	ns	
STOP condition setup time SCL ↑ → SDA ↑	t _{SUSTO}		4.0	-	0.6	-	μs	
Bus free time between "STOP condition" and "START condition"	t _{BUF}		4.7	-	1.3	-	μs	
Noise filter	t _{SP}		8MHz ≤ t _{CYCP} ≤ 40MHz	2 t _{CYCP} * ⁴	-	2 t _{CYCP} * ⁴	-	ns
		40MHz < t _{CYCP} ≤ 60MHz	3 t _{CYCP} * ⁴	-	3 t _{CYCP} * ⁴	-	ns	*5
		60MHz < t _{CYCP} ≤ 72MHz	4 t _{CYCP} * ⁴	-	4 t _{CYCP} * ⁴	-	ns	*5

*1 :R and C_L represent the pull-up resistor and load capacitance of the SCL and SDA lines, respectively.

V_p indicates the power supply voltage of the pull-up resistor and I_{OL} indicates V_{OL} guaranteed current.

*2 :The maximum t_{HDDAT} must satisfy that it does not extend at least "L" period (t_{LOW}) of device's SCL signal.

*3 :A high-speed mode I²C bus device can be used on a standard mode I²C bus system as long as the device satisfies the requirement of "t_{SUDAT} ≥ 250 ns".

*4 :t_{CYCP} is the APB bus clock cycle time.

About the APB bus number that I²C is connected to, see "■BLOCK DIAGRAM" in this data sheet.

To use I²C, set the peripheral bus clock at 8 MHz or more.

*5 :The number of the steps of the noise filter can be changed to 2, 3 and 4 steps by register settings.

Change the number of the noise filter steps according to APB2 bus clock frequency.

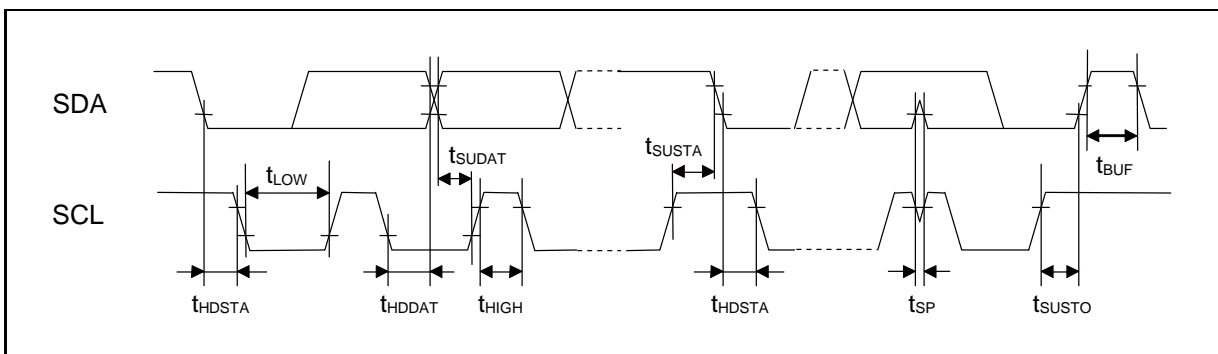

MB9B320M Series

(12) JTAG Timing

($V_{CC} = 2.7V$ to $5.5V$, $V_{SS} = 0V$, $T_a = -40^{\circ}C$ to $+105^{\circ}C$)

Parameter	Symbol	Pin name	Conditions	Value		Unit	Remarks
				Min	Max		
TMS, TDI setup time	t_{JTAGS}	TCK, TMS, TDI	$V_{CC} \geq 4.5V$	15	-	ns	
			$V_{CC} < 4.5V$				
TMS, TDI hold time	t_{JTAGH}	TCK, TMS, TDI	$V_{CC} \geq 4.5V$	15	-	ns	
			$V_{CC} < 4.5V$				
TDO delay time	t_{JTAGD}	TCK, TDO	$V_{CC} \geq 4.5V$	-	25	ns	
			$V_{CC} < 4.5V$	-	45		

Note: When the external load capacitance $C_L = 30pF$.

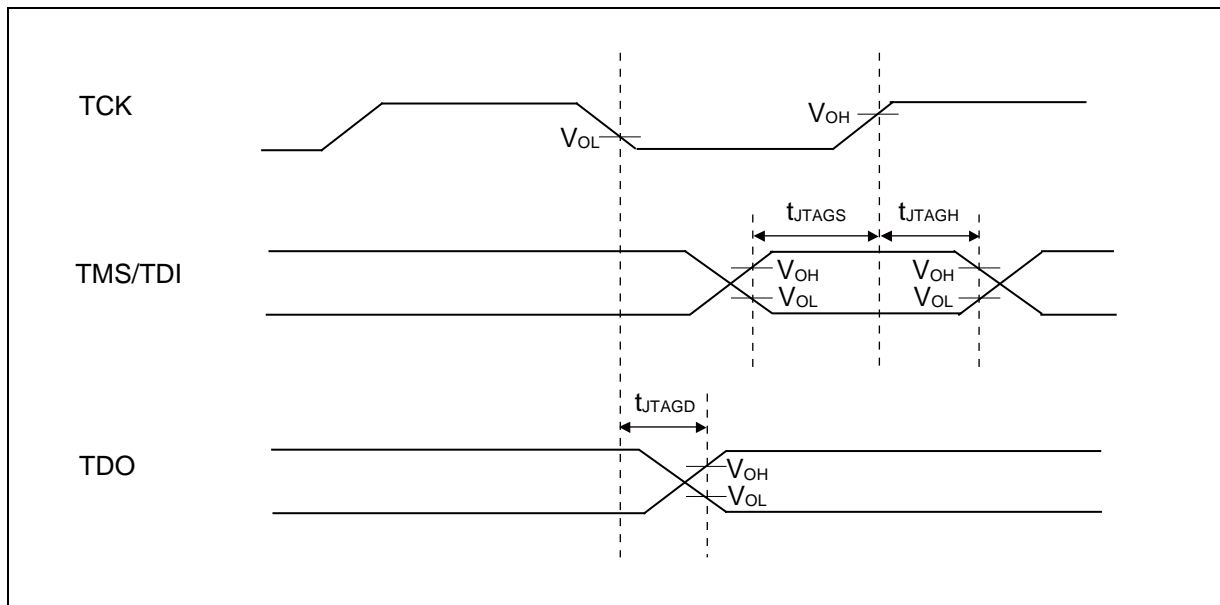

5. 12-bit A/D Converter

- Electrical characteristics for the A/D converter

($V_{CC} = AV_{CC} = 2.7V$ to $5.5V$, $V_{SS} = AV_{SS} = AVR_L = 0V$, $T_a = -40^{\circ}C$ to $+105^{\circ}C$)

Parameter	Symbol	Pin name	Value			Unit	Remarks
			Min	Typ	Max		
Resolution	-	-	-	-	12	bit	
Non-linearity error	-	-	- 4.5	-	+ 4.5	LSB	AVRH = 2.7V to 5.5V
Differential linearity error	-	-	- 2.5	-	+ 2.5	LSB	
Zero transition voltage	V_{OT}	AN00 to AN26	- 20	-	+ 20	mV	
Full-scale transition voltage	V_{FST}	AN00 to AN26	AVRH - 20	-	AVRH + 20	mV	
Conversion time	-	-	0.8* ¹	-	-	μs	$AV_{CC} \geq 4.5V$
Sampling time	T_s	-	* ²	-	10	μs	$AV_{CC} \geq 4.5V$
			* ²	-			$AV_{CC} < 4.5V$
Compare clock cycle* ³	T_{cck}	-	40	-	1000	ns	$AV_{CC} \geq 4.5V$
			50	-			$AV_{CC} < 4.5V$
State transition time to operation permission	T_{stt}	-	1.0	-	-	μs	
Power supply current (analog + digital)	-	AVCC	-	0.69	0.90	mA	A/D 1unit operation
			-	0.25	25.84	μA	When A/D stop
Reference power supply current (between AVRH to AVSS)	-	AVRH	-	1.1	1.97	mA	A/D 1unit operation AVRH=5.5V
			-	0.2	3.4	μA	When A/D stop
Analog input capacity	C_{AIN}	-	-	-	9.7	pF	
Analog input resistor	R_{AIN}	-	-	-	1.7	k Ω	$AV_{CC} \geq 4.5V$
					2.4		$AV_{CC} < 4.5V$
Interchannel disparity	-	-	-	-	4	LSB	
Analog port input current	-	AN00 to AN26	-	-	5	μA	
Analog input voltage	-	AN00 to AN26	AVSS	-	AVRH	V	
Reference voltage	-	AVRH	AVSS	-	AVCC	V	

*1: The conversion time is the value of sampling time (T_s) + compare time (T_c).

The condition of the minimum conversion time is when the value of sampling time: 240ns, the value of compare time: 560ns ($AV_{CC} \geq 4.5V$).

Ensure that it satisfies the value of the sampling time (T_s) and compare clock cycle (T_{cck}).

For setting*⁴ of the sampling time and compare clock cycle, see "Chapter: A/D Converter" in "FM3 Family PERIPHERAL MANUAL Analog Macro Part".

The A/D Converter register is set at the peripheral clock timing. The sampling clock and compare clock are set at Base clock (HCLK).

*2: A necessary sampling time changes by external impedance.

Ensure that it sets the sampling time to satisfy (Equation 1).

*3: The compare time (T_c) is the value of (Equation 2).

*4: The register setting of the A/D Converter is set at the timing of the APB bus clock.

The sampling clock and compare clock are set in base clock (HCLK).

About the APB bus number which the A/D Converter is connected to, see "■BLOCK DIAGRAM" in this data sheet.

MB9B320M Series

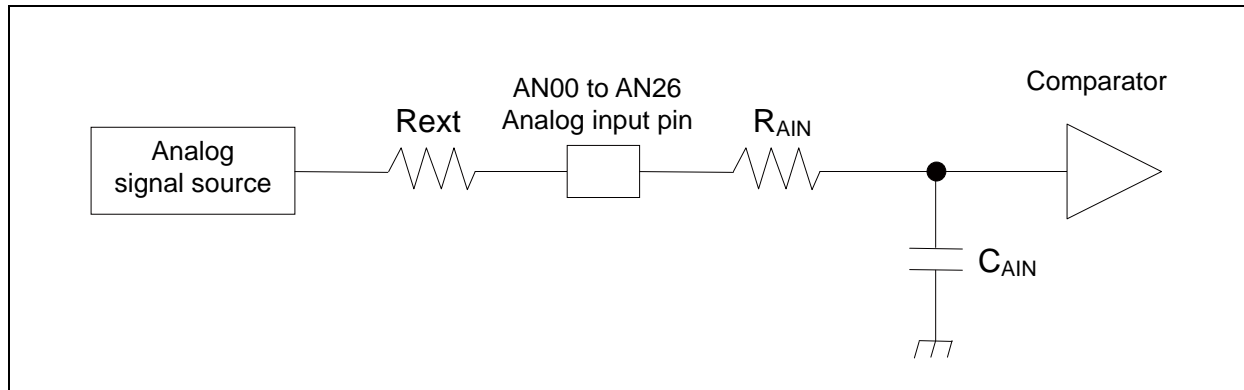

$$\text{(Equation 1) } T_s \geq (R_{AIN} + R_{ext}) \times C_{AIN} \times 9$$

T_s : Sampling time

R_{AIN} : input resistor of A/D = 1.5k Ω at 4.5 \leq AVCC \leq 5.5 ch.0 to ch.7
input resistor of A/D = 1.6k Ω at 4.5 \leq AVCC \leq 5.5 ch.8 to ch.15
input resistor of A/D = 1.7k Ω at 4.5 \leq AVCC \leq 5.5 ch.16 to ch.26
input resistor of A/D = 2.2k Ω at 2.7 \leq AVCC < 4.5 ch.0 to ch.7
input resistor of A/D = 2.3k Ω at 2.7 \leq AVCC < 4.5 ch.8 to ch.15
input resistor of A/D = 2.4k Ω at 2.7 \leq AVCC < 4.5 ch.16 to ch.26

C_{AIN} : input capacity of A/D = 9.7pF at 2.7 \leq AVCC \leq 5.5

R_{ext} : Output impedance of external circuit

$$\text{(Equation 2) } T_c = T_{ck} \times 14$$

T_c : Compare time

T_{ck} : Compare clock cycle

• Definition of 12-bit A/D Converter Terms

- Resolution : Analog variation that is recognized by an A/D converter.
- Linearity error : Deviation of the line between the zero-transition point (0b000000000000 \longleftrightarrow 0b000000000001) and the full-scale transition point (0b111111111110 \longleftrightarrow 0b111111111111) from the actual conversion characteristics.
- Differential linearity error : Deviation from the ideal value of the input voltage that is required to change the output code by 1 LSB.

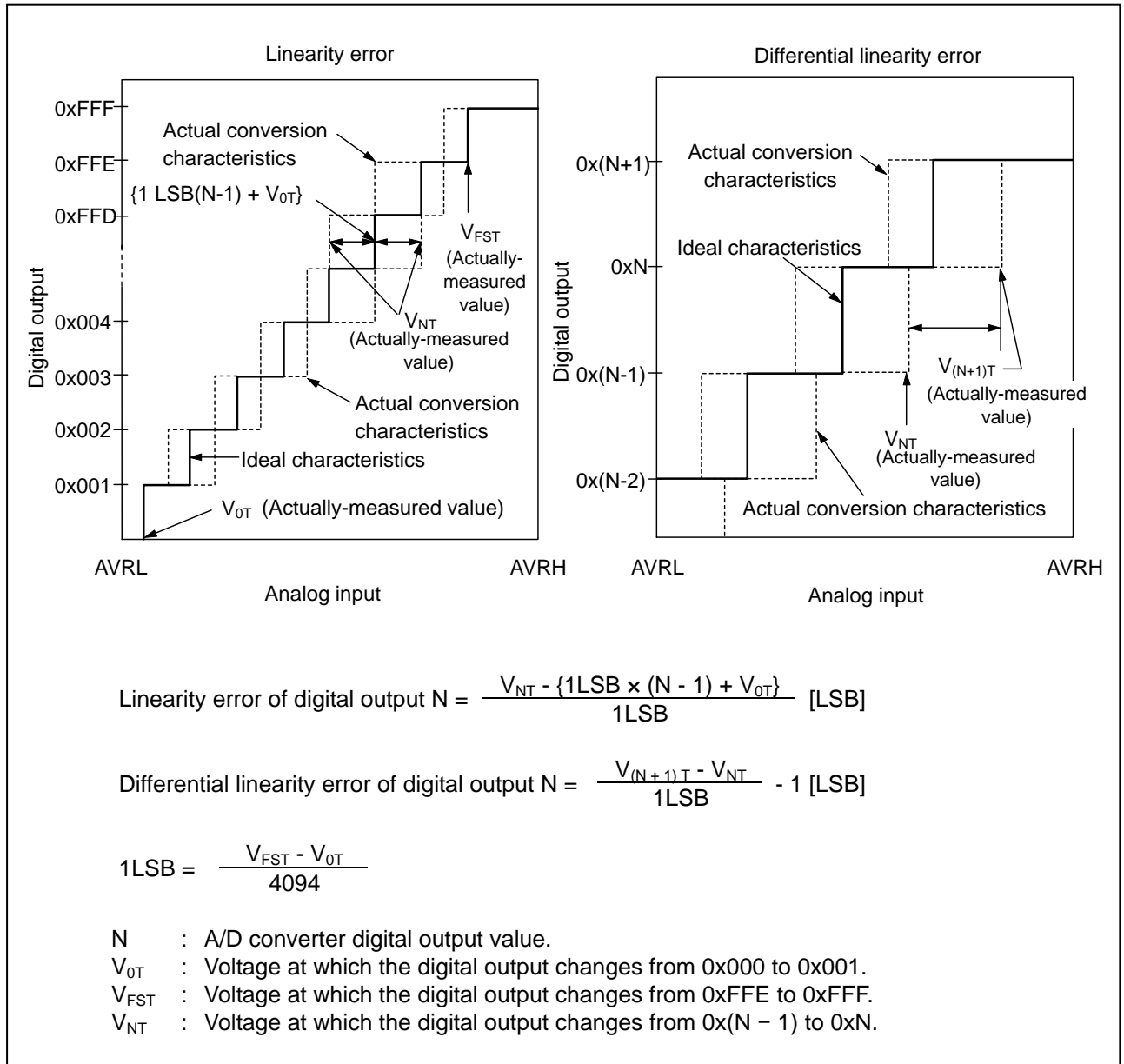

MB9B320M Series

6. 10-bit D/A Converter

- Electrical Characteristics for the D/A Converter

($V_{CC} = AV_{CC} = 2.7V$ to $5.5V$, $V_{SS} = AV_{SS} = AV_{RL} = 0V$, $T_a = -40^{\circ}C$ to $+105^{\circ}C$)

Parameter	Symbol	Pin name	Value			Unit	Remarks
			Min	Typ	Max		
Resolution	-	DAx	-	-	10	bit	
Conversion time	tc20		0.47	0.58	0.69	μs	Load 20pF
	tc100		2.37	2.90	3.43	μs	Load 100pF
Linearity error* ¹	INL		- 4.0	-	+ 4.0	LSB	
Differential linearity error* ^{1,*2}	DNL		- 0.9	-	+ 0.9	LSB	
Output Voltage offset	V _{OFF}		-	-	10.0	mV	Code is 0x000
			- 20.0	-	+ 5.4	mV	Code is 0x3FF
Analog output impedance	R _O		3.10	3.80	4.50	k Ω	D/A operation
			2.0	-	-	M Ω	D/A stop
Output undefined period	t _R		-	-	70	ns	
Power supply current* ¹	IDDA* ²	AVCC	250	315	380	μA	D/A operation AV _{CC} =3.3V
			380	475	580	μA	D/A operation AV _{CC} =5.0V
	IDSA		-	-	16	μA	D/A stop

*1: No-load

*2: Generates the max current by the CODE about 0x200

7. USB Characteristics

($V_{CC} = 2.7V$ to $5.5V$, $USBV_{CC} = 3.0V$ to $3.6V$, $V_{SS} = 0V$, $T_a = -40^{\circ}C$ to $+105^{\circ}C$)

Parameter	Symbol	Pin name	Conditions	Value		Unit	Remarks
				Min	Max		
Input characteristics	Input "H" level voltage	V_{IH}	-	2.0	$USBV_{CC} + 0.3$	V	*1
	Input "L" level voltage	V_{IL}	-	$V_{SS} - 0.3$	0.8	V	*1
	Differential input sensitivity	V_{DI}	-	0.2	-	V	*2
	Different common mode range	V_{CM}	-	0.8	2.5	V	*2
Output characteristics	Output "H" level voltage	V_{OH}	External pull-down resistor = $15k\Omega$	2.8	3.6	V	*3
	Output "L" level voltage	V_{OL}	External pull-up resistor = $1.5k\Omega$	0.0	0.3	V	*3
	Crossover voltage	V_{CRS}	-	1.3	2.0	V	*4
	Rising time	t_{FR}	Full-Speed	4	20	ns	*5
	Falling time	t_{FF}	Full-Speed	4	20	ns	*5
	Rising/ falling time matching	t_{FRFM}	Full-Speed	90	111.11	%	*5
	Output impedance	Z_{DRV}	Full-Speed	28	44	Ω	*6
	Rising time	t_{LR}	Low-Speed	75	300	ns	*7
	Falling time	t_{LF}	Low-Speed	75	300	ns	*7
	Rising/ falling time matching	t_{LRFM}	Low-Speed	80	125	%	*7

*1 : The switching threshold voltage of the Single-End-Receiver of USB I/O buffer is set as within V_{IL} (Max) = 0.8V, V_{IH} (Min) = 2.0 V (TTL input standard).

There are some hysteresis to lower noise sensitivity.

*2 : Use the differential-Receiver to receive the USB differential data signal.

The Differential-Receiver has 200 mV of differential input sensitivity when the differential data input is within 0.8 V to 2.5 V to the local ground reference level.

The voltage range above is said to be the common mode input voltage range.

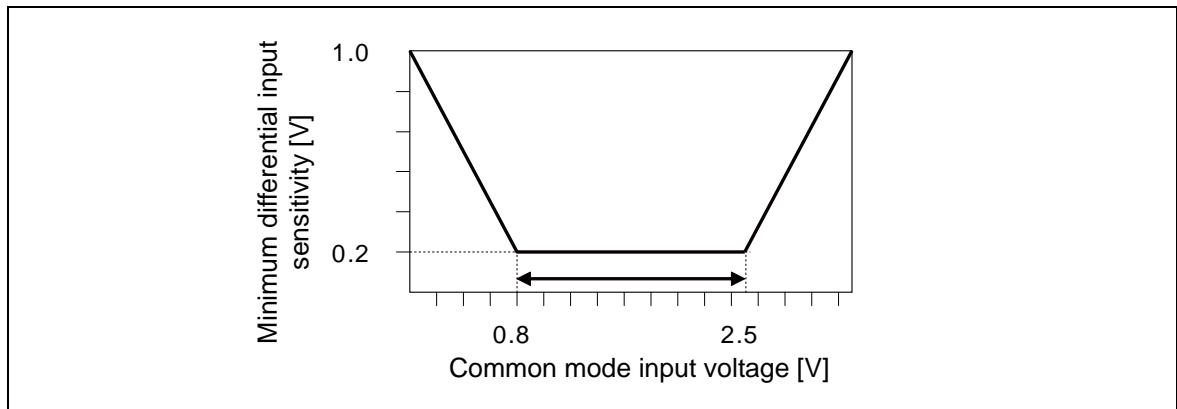

MB9B320M Series

*3 : The output drive capability of the driver is below 0.3 V at Low-State (V_{OL}) (to 3.6 V and 1.5 k Ω load), and 2.8 V or above (to ground and 15 k Ω load) at High-State (V_{OH}).

*4 : The cross voltage of the external differential output signal (D + /D -) of USB I/O buffer is within 1.3 V to 2.0 V.

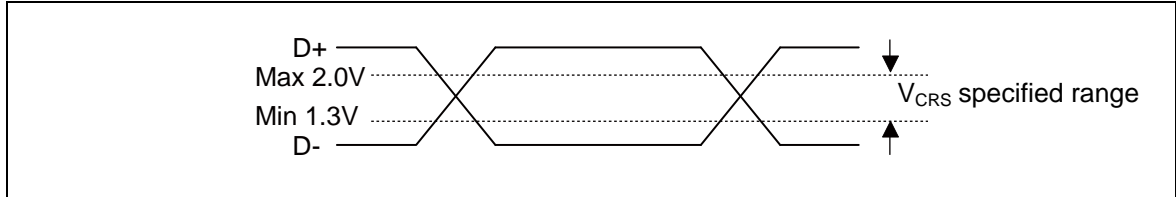

*5 : They indicate rising time (T_{rise}) and falling time (T_{fall}) of the full-speed differential data signal. They are defined by the time between 10% and 90% of the output signal voltage. For full-speed buffer, T_r/T_f ratio is regulated as within $\pm 10\%$ to minimize RFI emission.

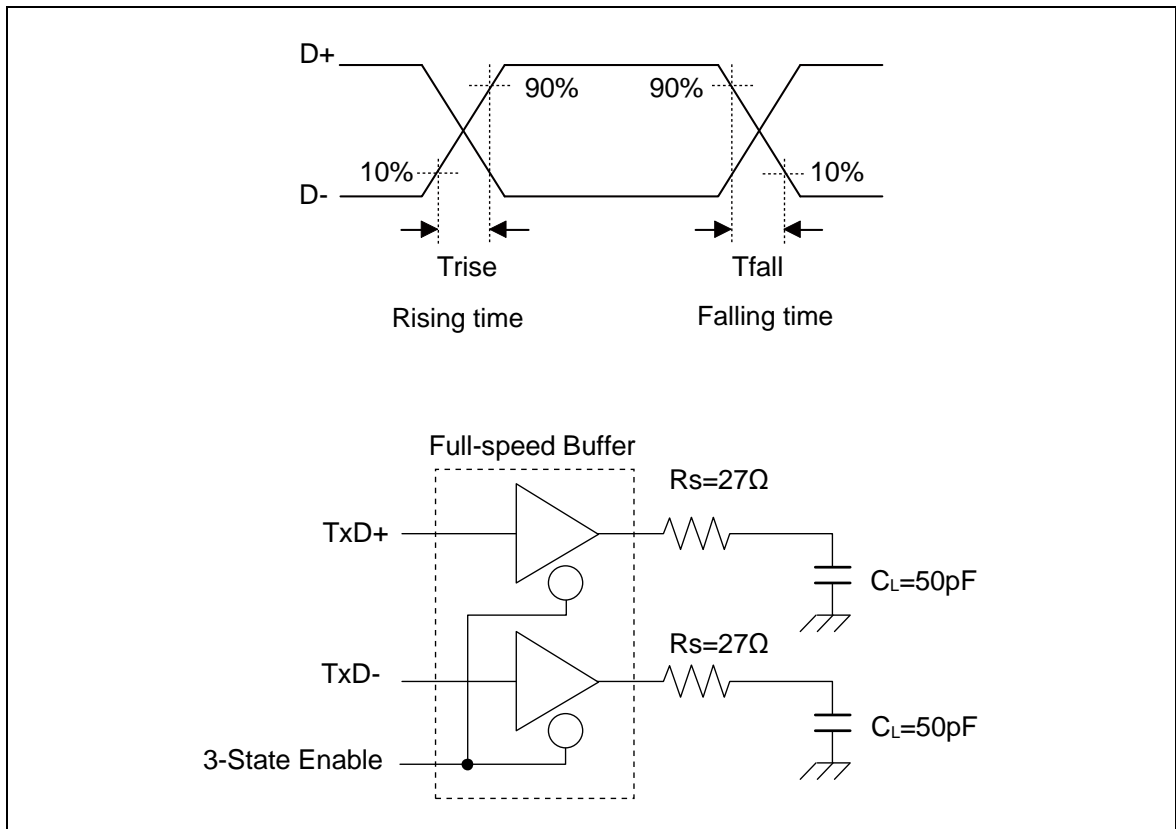

*6 : USB Full-speed connection is performed via twist pair cable shield with $90\Omega \pm 15\%$ characteristic impedance (Differential Mode).

USB standard defines that output impedance of USB driver must be in range from 28Ω to 44Ω . So, discrete series resistor (R_s) addition is defined in order to satisfy the above definition and keep balance.

When using this USB I/O, use it with 25Ω to 30Ω (recommendation value 27Ω) Series resistor R_s .

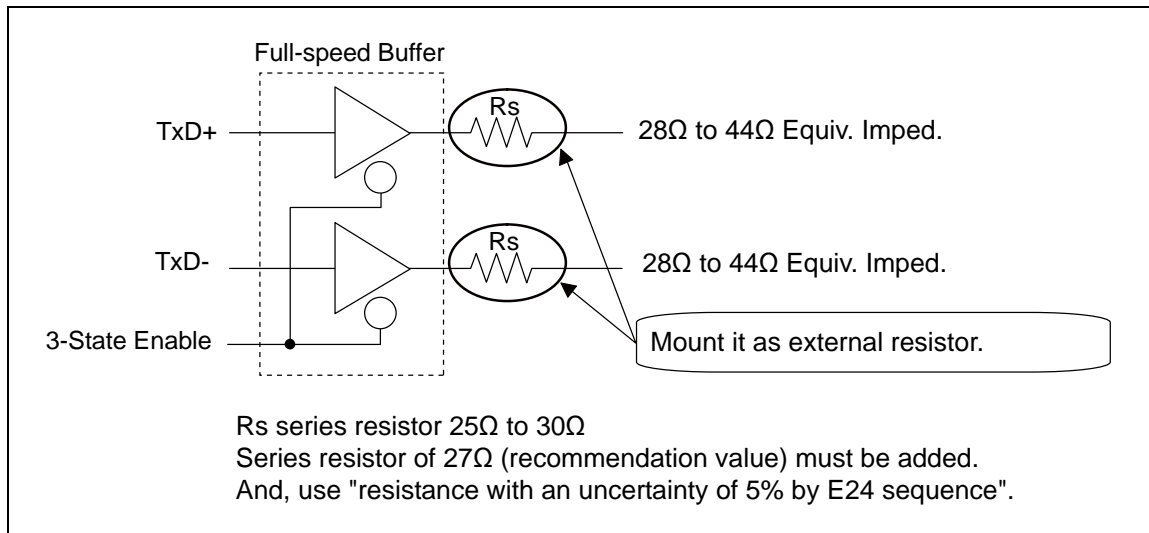

*7 : They indicate rising time (T_{rise}) and falling time (T_{fall}) of the low-speed differential data signal. They are defined by the time between 10% and 90% of the output signal voltage.

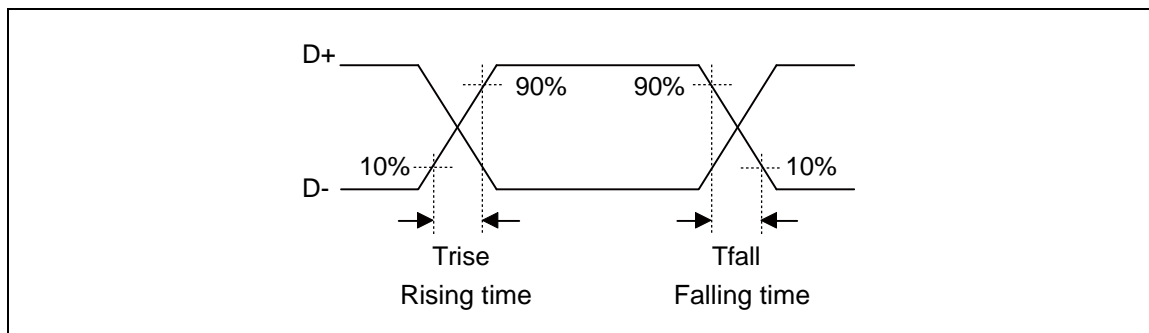

See "• Low-Speed Load (Compliance Load)" for conditions of the external load.

MB9B320M Series

- Low-Speed Load (Upstream Port Load) - Reference 1

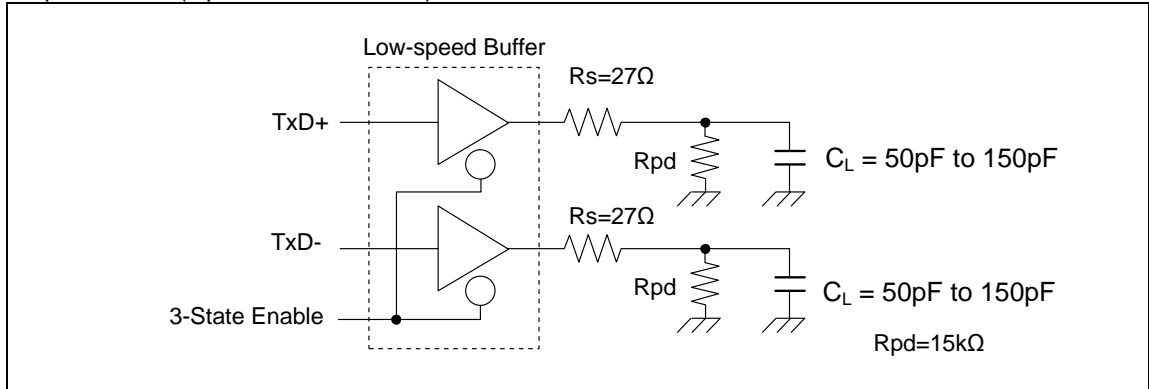

- Low-Speed Load (Downstream Port Load) - Reference 2

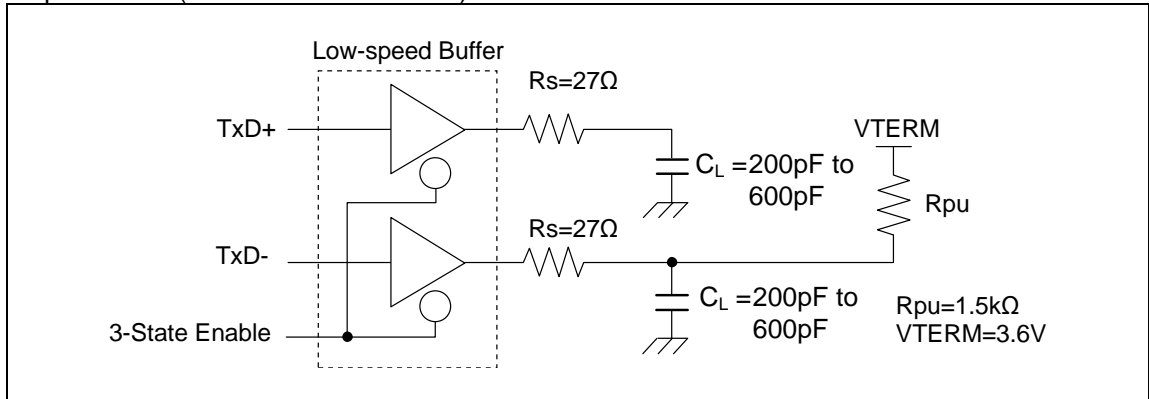

- Low-Speed Load (Compliance Load)

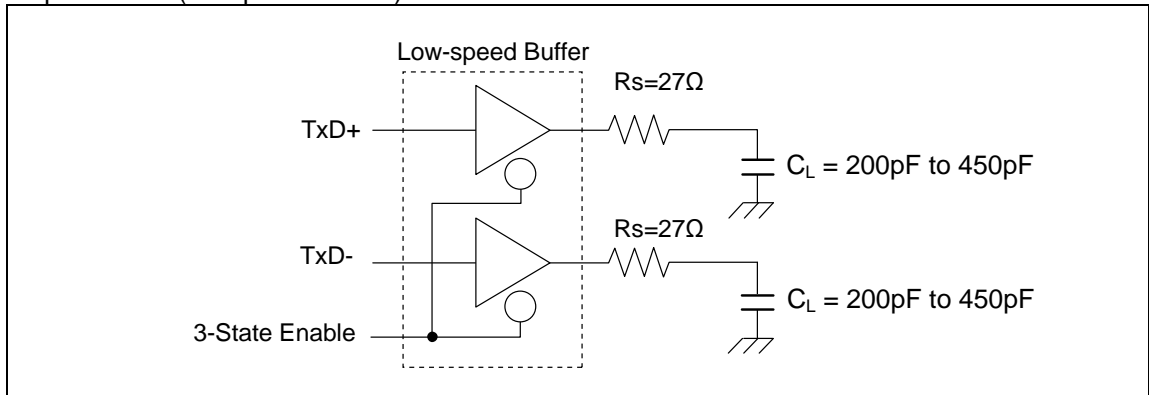

8. Low-Voltage Detection Characteristics

(1) Low-Voltage Detection Reset

(Ta = - 40°C to + 105°C)

Parameter	Symbol	Conditions	Value			Unit	Remarks
			Min	Typ	Max		
Detected voltage	VDL	SVHR=0000	2.25	2.45	2.65	V	When voltage drops
Released voltage	VDH		2.30	2.50	2.70		When voltage rises
Detected voltage	VDL	SVHR=0001	2.39	2.60	2.81	V	When voltage drops
Released voltage	VDH		2.48	2.70	2.92		When voltage rises
Detected voltage	VDL	SVHR=0010	2.48	2.70	2.92	V	When voltage drops
Released voltage	VDH		2.58	2.80	3.02		When voltage rises
Detected voltage	VDL	SVHR=0011	2.58	2.80	3.02	V	When voltage drops
Released voltage	VDH		2.67	2.90	3.13		When voltage rises
Detected voltage	VDL	SVHR=0100	2.76	3.00	3.24	V	When voltage drops
Released voltage	VDH		2.85	3.10	3.35		When voltage rises
Detected voltage	VDL	SVHR=0101	2.94	3.20	3.46	V	When voltage drops
Released voltage	VDH		3.04	3.30	3.56		When voltage rises
Detected voltage	VDL	SVHR=0110	3.31	3.60	3.89	V	When voltage drops
Released voltage	VDH		3.40	3.70	4.00		When voltage rises
Detected voltage	VDL	SVHR=0111	3.40	3.70	4.00	V	When voltage drops
Released voltage	VDH		3.50	3.80	4.10		When voltage rises
Detected voltage	VDL	SVHR=1000	3.68	4.00	4.32	V	When voltage drops
Released voltage	VDH		3.77	4.10	4.43		When voltage rises
Detected voltage	VDL	SVHR=1001	3.77	4.10	4.43	V	When voltage drops
Released voltage	VDH		3.86	4.20	4.54		When voltage rises
Detected voltage	VDL	SVHR=1010	3.86	4.20	4.54	V	When voltage drops
Released voltage	VDH		3.96	4.30	4.64		When voltage rises
LVD stabilization wait time	T _{LVDW}	-	-	-	5200 × t _{CYCP} *	μs	

*: t_{CYCP} indicates the APB2 bus clock cycle time.

(2) Interrupt of Low-Voltage Detection

(Ta = - 40°C to + 105°C)

Parameter	Symbol	Conditions	Value			Unit	Remarks
			Min	Typ	Max		
Detected voltage	VDL	SVHI = 0011	2.58	2.80	3.02	V	When voltage drops
Released voltage	VDH		2.67	2.90	3.13		When voltage rises
Detected voltage	VDL	SVHI = 0100	2.76	3.00	3.24	V	When voltage drops
Released voltage	VDH		2.85	3.10	3.35		When voltage rises
Detected voltage	VDL	SVHI = 0101	2.94	3.20	3.46	V	When voltage drops
Released voltage	VDH		3.04	3.30	3.56		When voltage rises
Detected voltage	VDL	SVHI = 0110	3.31	3.60	3.89	V	When voltage drops
Released voltage	VDH		3.40	3.70	4.00		When voltage rises
Detected voltage	VDL	SVHI = 0111	3.40	3.70	4.00	V	When voltage drops
Released voltage	VDH		3.50	3.80	4.10		When voltage rises
Detected voltage	VDL	SVHI = 1000	3.68	4.00	4.32	V	When voltage drops
Released voltage	VDH		3.77	4.10	4.43		When voltage rises
Detected voltage	VDL	SVHI = 1001	3.77	4.10	4.43	V	When voltage drops
Released voltage	VDH		3.86	4.20	4.54		When voltage rises
Detected voltage	VDL	SVHI = 1010	3.86	4.20	4.54	V	When voltage drops
Released voltage	VDH		3.96	4.30	4.64		When voltage rises
LVD stabilization wait time	T _{LVDW}	-	-	-	5200 × t _{CYCP} *	μs	

*: t_{CYCP} indicates the APB2 bus clock cycle time.

MB9B320M Series

9. MainFlash Memory Write/Erase Characteristics

($V_{CC} = 2.7V$ to $5.5V$, $T_a = -40^{\circ}C$ to $+105^{\circ}C$)

Parameter		Value			Unit	Remarks
		Min	Typ	Max		
Sector erase time	Large Sector	-	1.1	2.7	s	Includes write time prior to internal erase
	Small Sector		0.3	0.9		
Half word (16-bit) write time		-	16	310	μs	Not including system-level overhead time
Chip erase time		-	6.89	18	s	Includes write time prior to internal erase

Write cycles and data hold time

Erase/write cycles (cycle)	Data hold time (year)	Remarks
1,000	20*	
10,000	10*	

*: This value comes from the technology qualification (using Arrhenius equation to translate high temperature acceleration test result into average temperature value at $+85^{\circ}C$).

MB9B320M Series

■ ORDERING INFORMATION

Part number	Package
MB9BF321KQN	Plastic • QFN(0.5mm pitch),48-pin (LCC-48P-M73)
MB9BF322KQN	
MB9BF324KQN	
MB9BF321KPMC	Plastic • LQFP(0.5mm pitch),48-pin (FPT-48P-M49)
MB9BF322KPMC	
MB9BF324KPMC	
MB9BF321LQN	Plastic • QFN(0.5mm pitch),64-pin (LCC-64P-M24)
MB9BF322LQN	
MB9BF324LQN	
MB9BF321LPMC1	Plastic • LQFP(0.5mm pitch),64-pin (FPT-64P-M38)
MB9BF322LPMC1	
MB9BF324LPMC1	
MB9BF321LPMC	Plastic • LQFP(0.65mm pitch),64-pin (FPT-64P-M39)
MB9BF322LPMC	
MB9BF324LPMC	
MB9BF321MPMC	Plastic • LQFP(0.5mm pitch),80-pin (FPT-80P-M37)
MB9BF322MPMC	
MB9BF324MPMC	
MB9BF321MPMC1	Plastic • LQFP(0.65mm pitch),80-pin (FPT-80P-M40)
MB9BF322MPMC1	
MB9BF324MPMC1	
MB9BF321MBGL	Plastic • PFBGA(0.5mm pitch),96-pin (BGA-96P-M07)
MB9BF322MBGL	
MB9BF324MBGL	

MB9B320M Series

■ PACKAGE DIMENSIONS

<p>80-pin plastic LQFP</p> <p>(FPT-80P-M37)</p>	Lead pitch	0.50 mm
	Package width × package length	12.00 mm × 12.00 mm
	Lead shape	Gullwing
	Lead bend direction	Normal bend
	Sealing method	Plastic mold
	Mounting height	1.70 mm MAX
	Weight	0.47 g

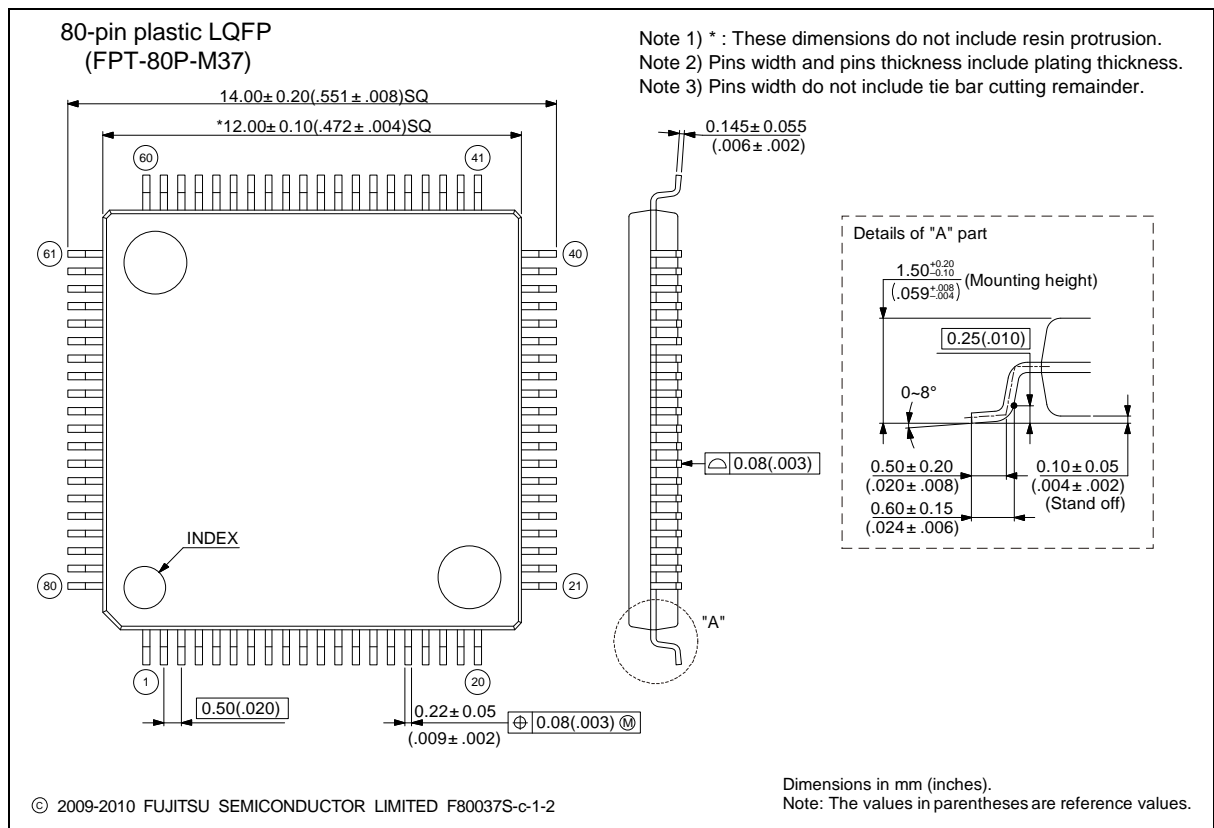

Please check the latest package dimension at the following URL.
<http://edevice.fujitsu.com/package/en-search/>

MB9B320M Series

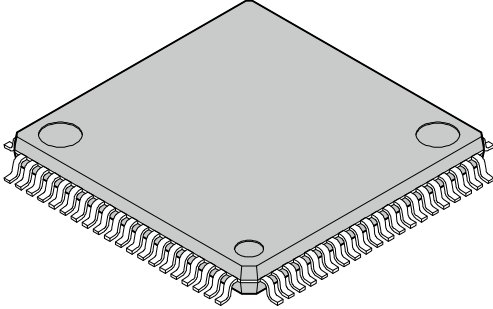
<p style="text-align: center;">80-pin plastic LQFP</p>  <p style="text-align: center;">(FPT-80P-M40)</p>	Lead pitch	0.65 mm
	Package width × package length	14.00 mm × 14.00 mm
	Lead shape	Gullwing
	Sealing method	Plastic mold
	Mounting height	1.60 mm Max.
	Code (Reference)	P-LQFP80-14 × 14-0.65

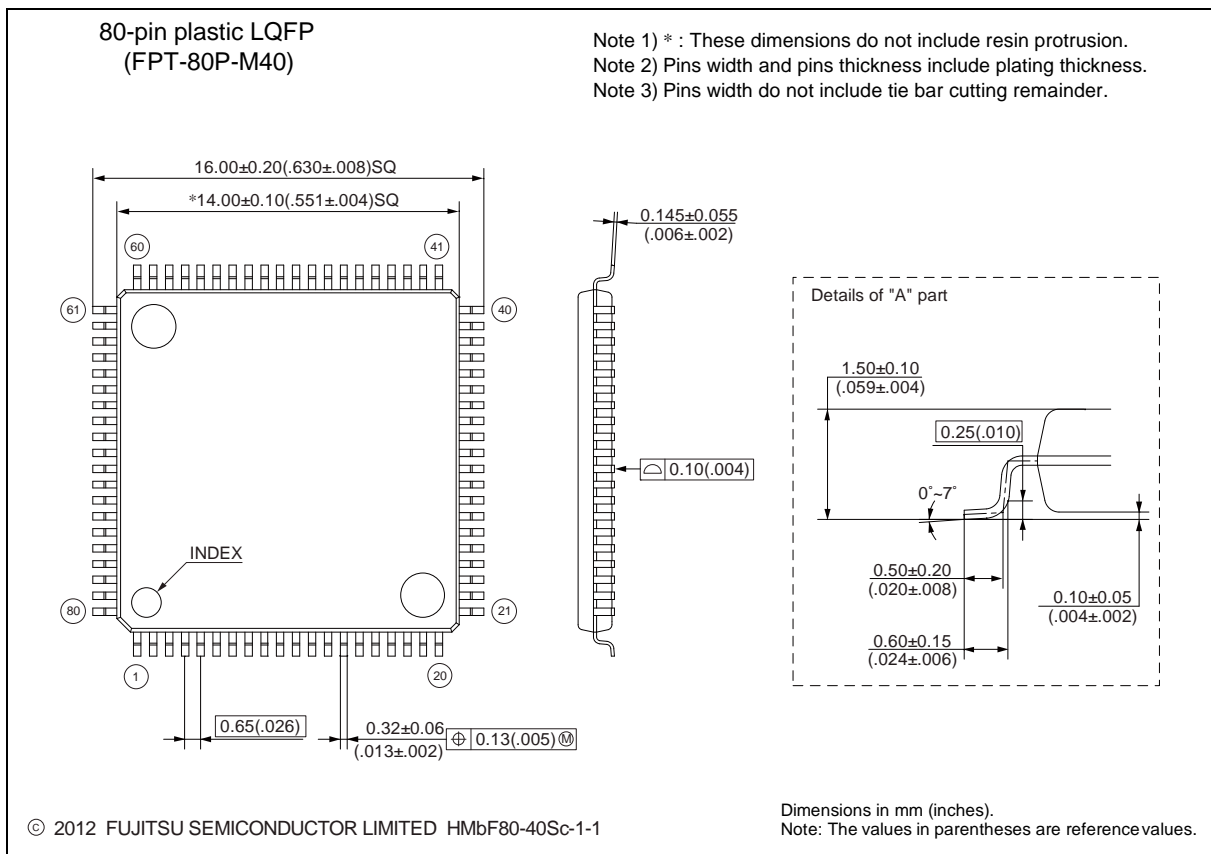

Please check the latest package dimension at the following URL.
<http://edevice.fujitsu.com/package/en-search/>

MB9B320M Series

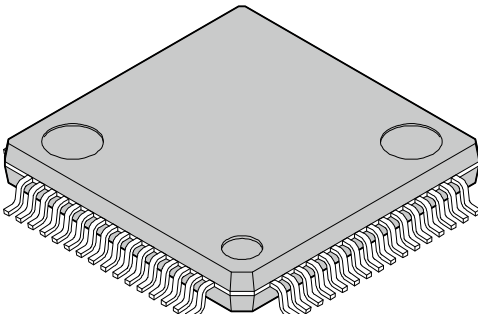
<p>64-pin plastic LQFP</p>  <p>(FPT-64P-M38)</p>	Lead pitch	0.50 mm
	Package width × package length	10.00 mm × 10.00 mm
	Lead shape	Gullwing
	Lead bend direction	Normal bend
	Sealing method	Plastic mold
	Mounting height	1.70 mm MAX
	Weight	0.32 g

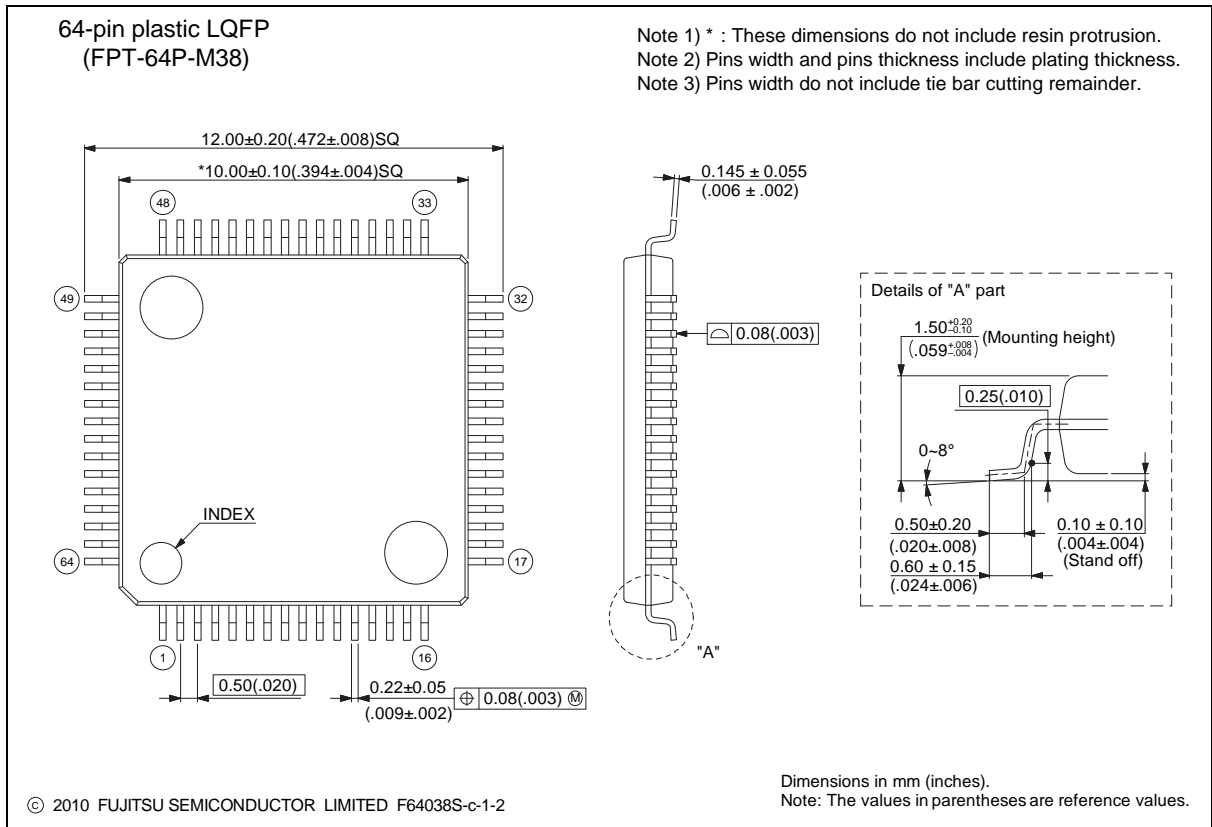

Please check the latest package dimension at the following URL.
<http://edevice.fujitsu.com/package/en-search/>

MB9B320M Series

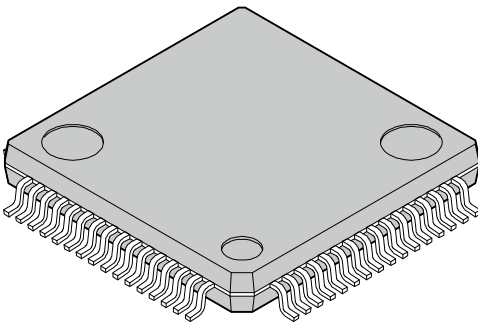
<p>64-pin plastic LQFP</p>  <p>(FPT-64P-M39)</p>	Lead pitch	0.65 mm
	Package width × package length	12.00 mm × 12.00 mm
	Lead shape	Gullwing
	Sealing method	Plastic mold
	Mounting height	1.70 mm MAX
	Weight	0.47 g

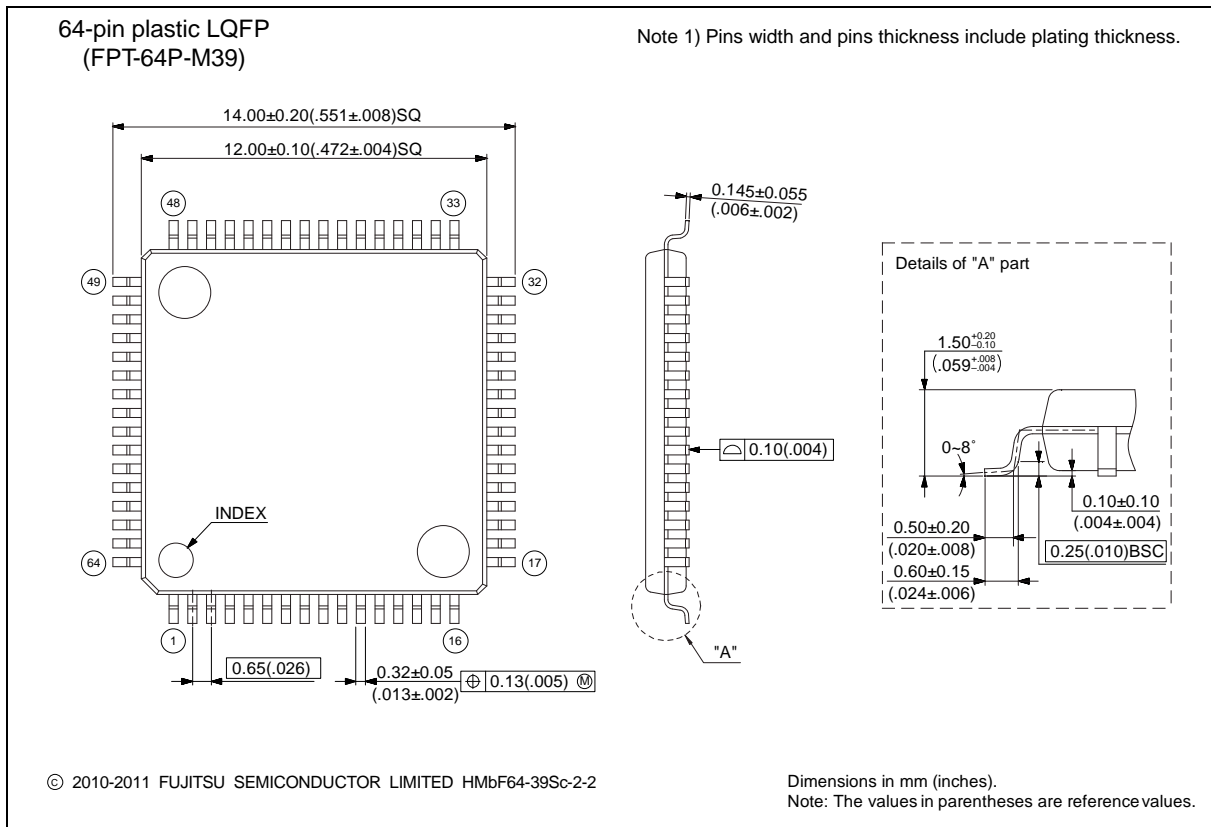

Please check the latest package dimension at the following URL.
<http://edevice.fujitsu.com/package/en-search/>

MB9B320M Series

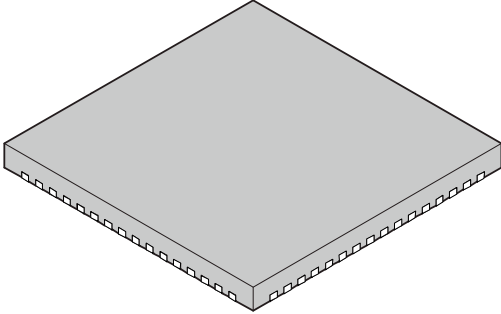
<p>64-pin plastic QFN</p>  <p>(LCC-64P-M24)</p>	Lead pitch	0.50 mm
	Package width × package length	9.00 mm × 9.00 mm
	Sealing method	Plastic mold
	Mounting height	0.90 mm MAX
	Weight	-

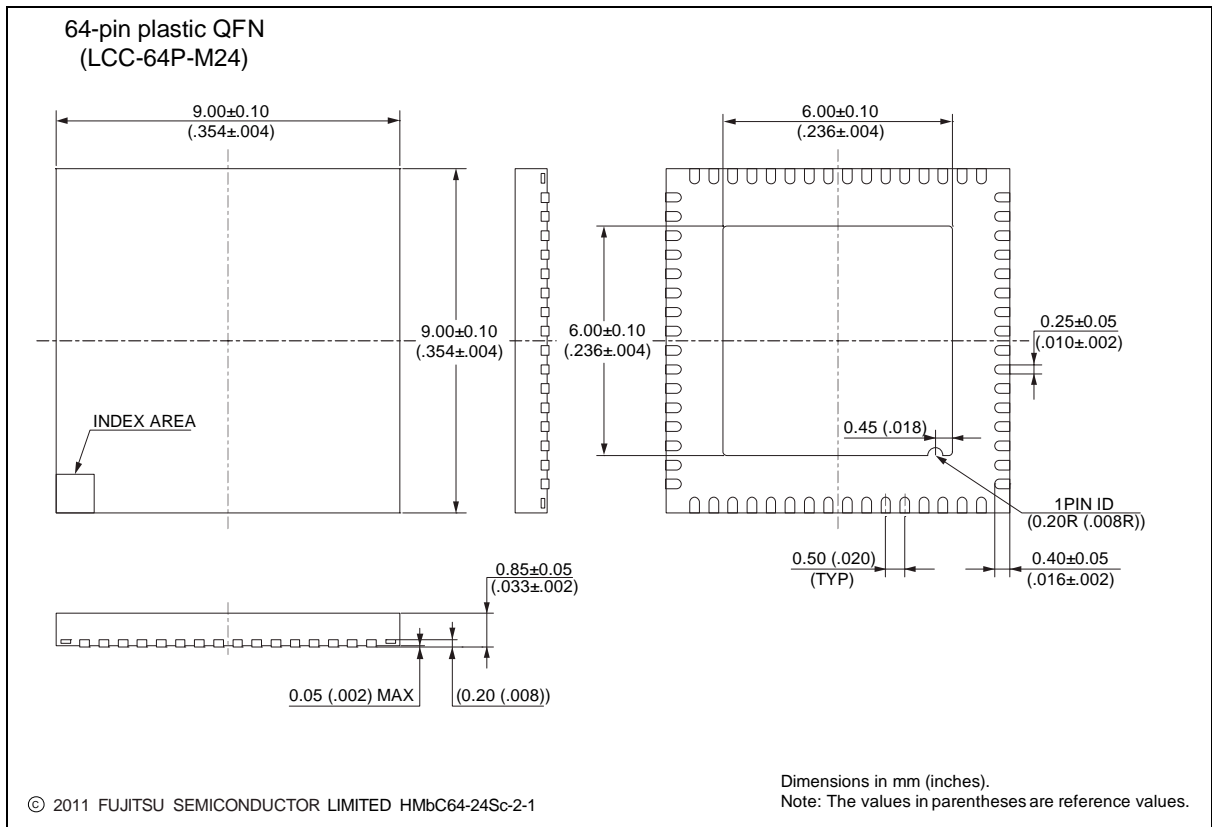

Please check the latest package dimension at the following URL.
<http://edevice.fujitsu.com/package/en-search/>

MB9B320M Series

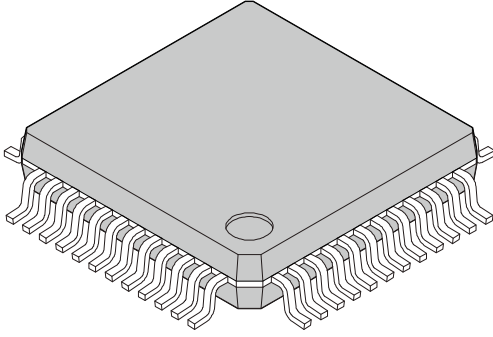
<p>48-pin plastic LQFP</p>  <p>(FPT-48P-M49)</p>	Lead pitch	0.50 mm
	Package width x package length	7.00 mm x 7.00 mm
	Lead shape	Gullwing
	Lead bend direction	Normal bend
	Sealing method	Plastic mold
	Mounting height	1.70 mm MAX
	Weight	0.17 g

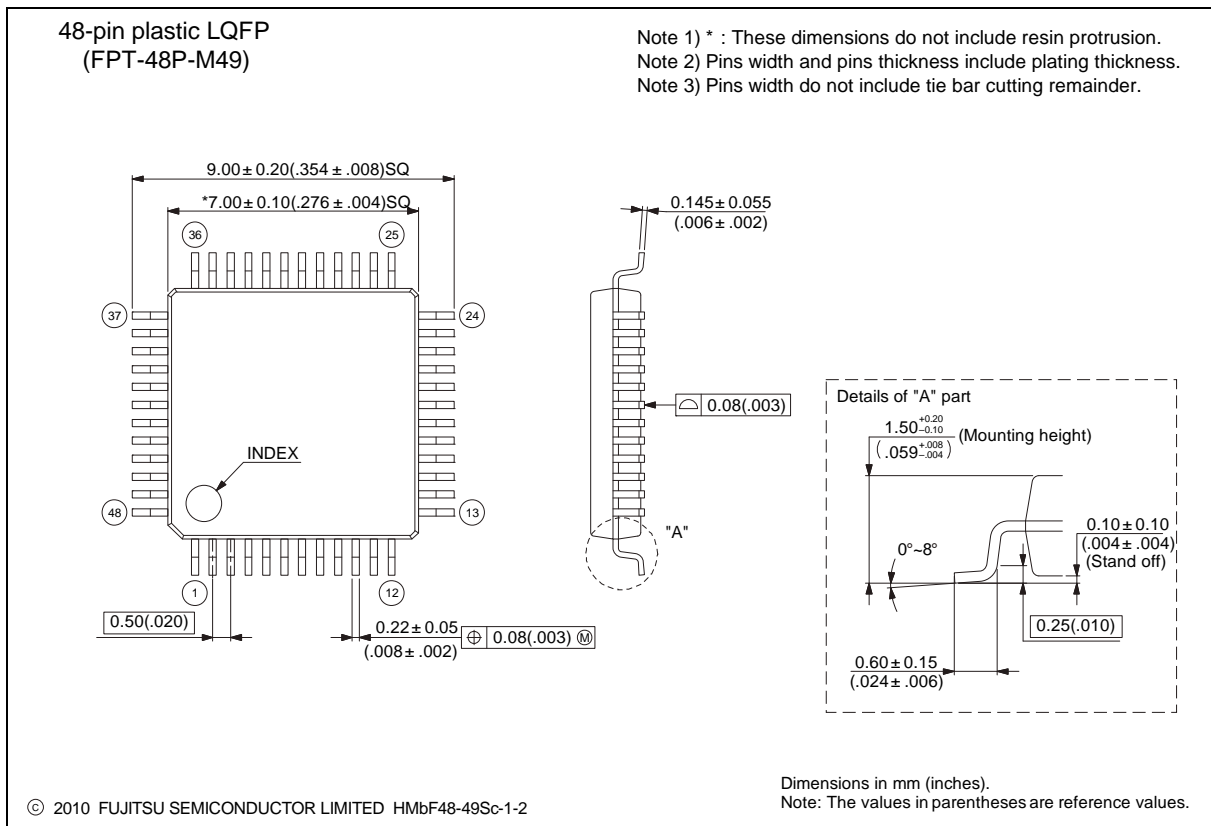

Please check the latest package dimension at the following URL.
<http://edevice.fujitsu.com/package/en-search/>

MB9B320M Series

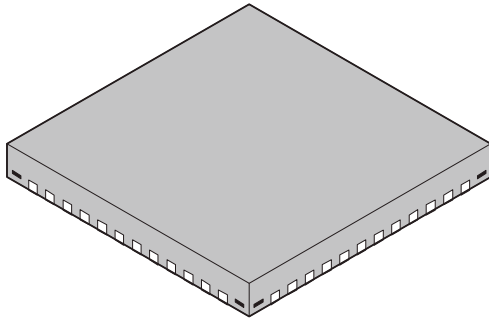
<p style="text-align: center;">48-pin plastic QFN</p>  <p style="text-align: center;">(LCC-48P-M73)</p>	Lead pitch	0.5 mm
	Package width × package length	7.00 mm × 7.00 mm
	Sealing method	Plastic mold
	Mounting height	0.90 mm MAX
	Weight	—

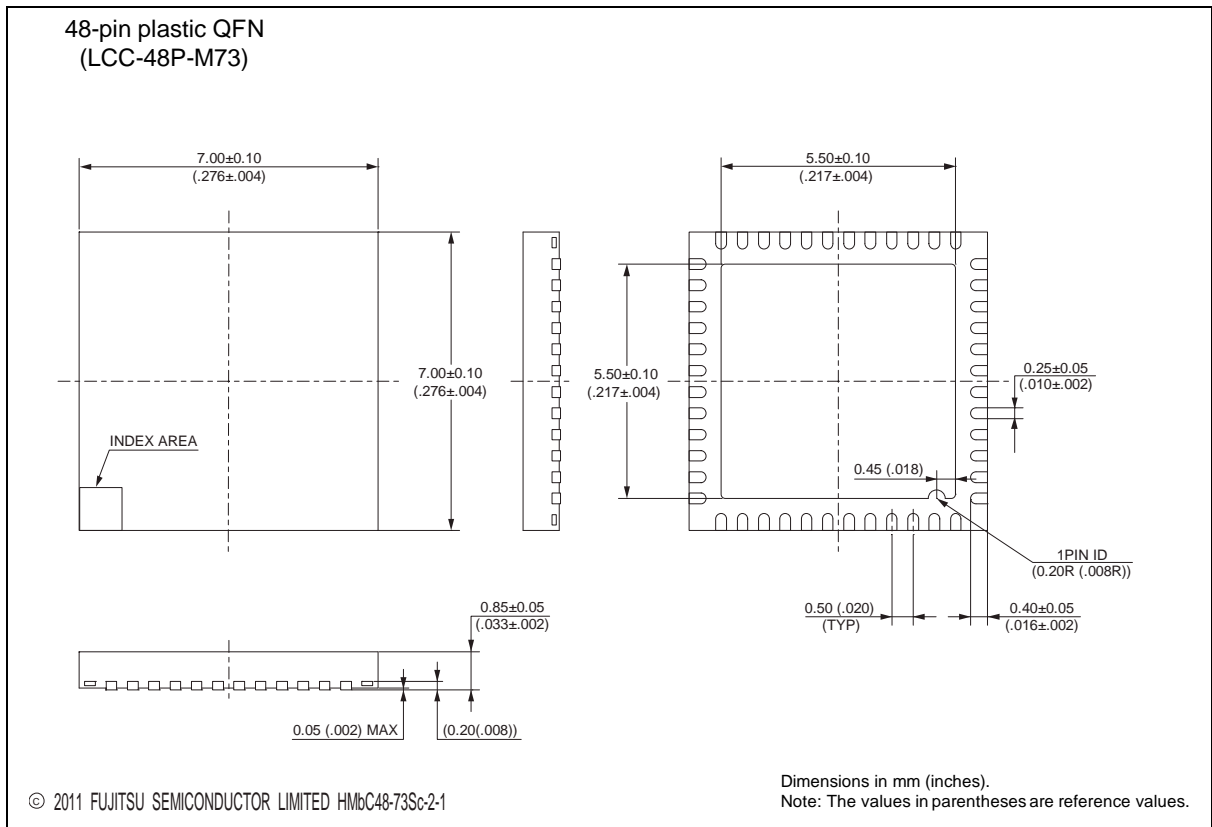

Please check the latest package dimension at the following URL.
<http://edevice.fujitsu.com/package/en-search/>

MB9B320M Series

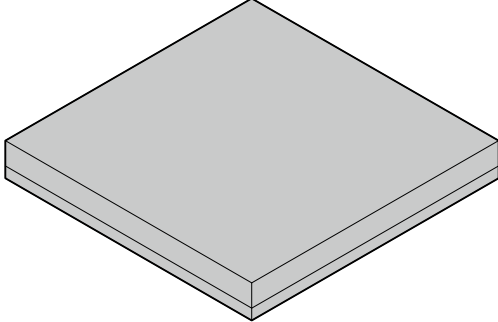
<p>96-pin plastic FBGA</p>  <p>(BGA-96P-M07)</p>	Lead pitch	0.5 mm
	Package width x package length	6.00 mm x 6.00 mm
	Lead shape	Ball
	Sealing method	Plastic mold
	Mounting height	1.30 mm MAX
	Weight	0.08 g

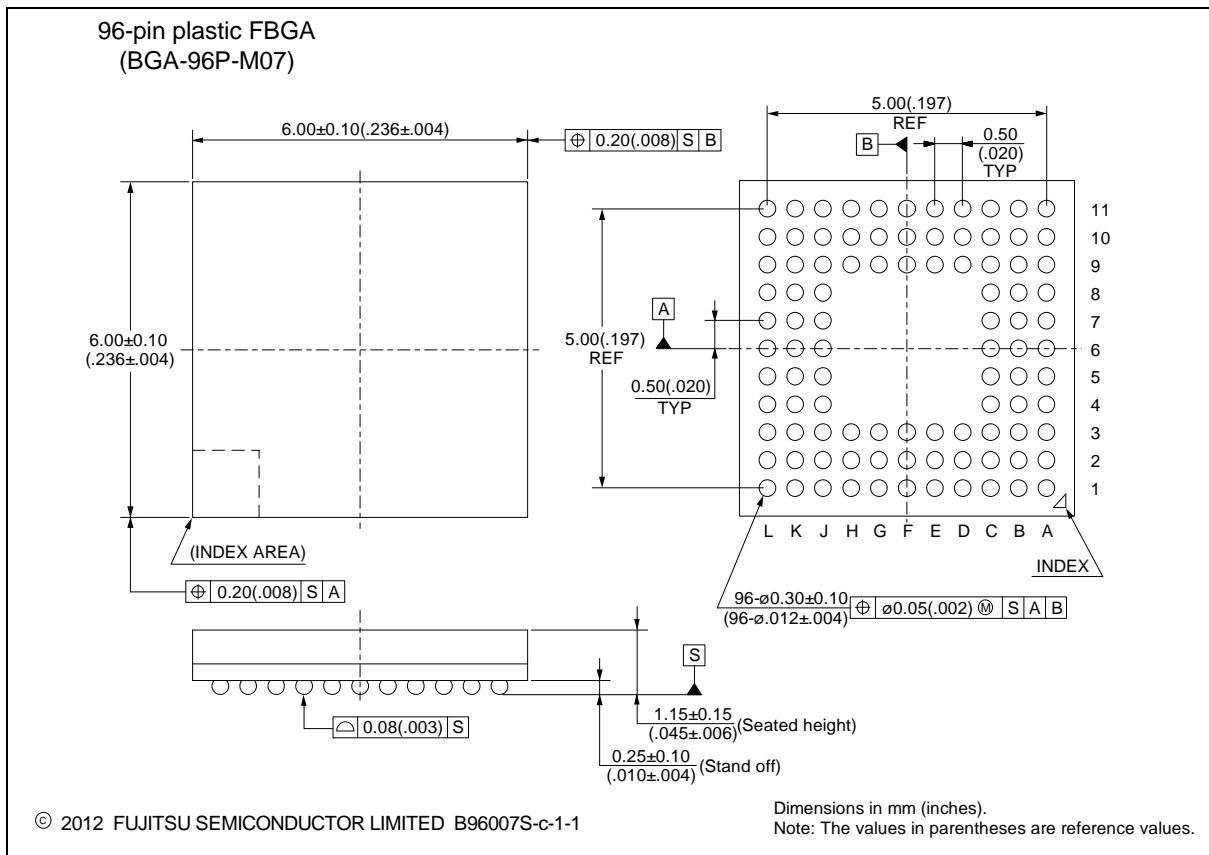

MB9B320M Series

■ MAJOR CHANGES IN THIS EDITION

A change on a page is indicated by a vertical line drawn on the left side of that page.

Page	Section	Change Results
-	-	Preliminary → Data Sheet
3	■FEATURES <ul style="list-style-type: none"> A/D Converter (Max 26channels) 	Revised the conversion time: 1.0 μ s → 0.8 μ s
6	<ul style="list-style-type: none"> UniqueID 	Added the "Unique ID".
7	■PRODUCT LINEUP <ul style="list-style-type: none"> Function 	Added the "Unique ID".
16 to 18	■LIST OF PIN FUNCTIONS <ul style="list-style-type: none"> List of pin numbers 	<ul style="list-style-type: none"> Corrected the I/O circuit type. Corrected the Pin state type.
33	<ul style="list-style-type: none"> List of pin functions 	Corrected the Pin function.
39	■I/O CIRCUIT TYPE	Added the "Type: L".
46	■BLOCK DIAGRAM	Corrected the figure. - TIOA: input → input/output - TIOB: output → input
55	■ELECTRICAL CHARACTERISTICS <ol style="list-style-type: none"> Absolute Maximum Ratings 	Revised the value of "TBD".
57	<ol style="list-style-type: none"> Recommended Operating Conditions 	Revised the Condition of "Operating temperature".
58, 59	<ol style="list-style-type: none"> DC Characteristics <ol style="list-style-type: none"> Current Rating 	<ul style="list-style-type: none"> Revised the value of "TBD". Added "Flash memory write/erase current".
62	<ol style="list-style-type: none"> AC Characteristics <ol style="list-style-type: none"> Built-in CR Oscillation Characteristics 	<ul style="list-style-type: none"> Revised the Condition. Revised the footnote.
63	<ol style="list-style-type: none"> <ol style="list-style-type: none"> Operating Conditions of Main PLL (In the case of using built-in high-speed CR for input clock of main PLL) 	Revised the value of "TBD".
79	<ol style="list-style-type: none"> 12-bit A/D Converter <ul style="list-style-type: none"> Electrical characteristics for the A/D converter 	<ul style="list-style-type: none"> Deleted "(Preliminary value)". Revised the conversion time. Min: 1.0μs → 0.8μs Revised the value of "Compare clock cycle ($A_{V_{CC}} \geq 4.5V$)". Min: 50ns → 40ns Revised the footnote.
82	<ol style="list-style-type: none"> 10-bit D/A Converter 	Deleted "(Preliminary value)".
87	<ol style="list-style-type: none"> Low-Voltage Detection Characteristics 	Revised the value of "TBD".

Page	Section	Change Results
88	9. MainFlash Memory Write/Erase Characteristics	<ul style="list-style-type: none">• Revised the value of "TBD".• Revised the value of "Sector erase time".<ul style="list-style-type: none">- Large Sector Typ: 1.065s → 1.1s- Small Sector Typ: 0.606s → 0.3s• Revised the value of "Chip erase time". Typ: 9.11s → 6.8s• Deleted "(targeted value)".

MB9B320M Series

FUJITSU SEMICONDUCTOR LIMITED

Nomura Fudosan Shin-yokohama Bldg. 10-23, Shin-yokohama 2-Chome,
Kohoku-ku Yokohama Kanagawa 222-0033, Japan

Tel: +81-45-415-5858

<http://jp.fujitsu.com/fsl/en/>

For further information please contact:

North and South America

FUJITSU SEMICONDUCTOR AMERICA, INC.
1250 E. Arques Avenue, M/S 333
Sunnyvale, CA 94085-5401, U.S.A.
Tel: +1-408-737-5600 Fax: +1-408-737-5999
<http://us.fujitsu.com/micro/>

Asia Pacific

FUJITSU SEMICONDUCTOR ASIA PTE. LTD.
151 Lorong Chuan,
#05-08 New Tech Park 556741 Singapore
Tel : +65-6281-0770 Fax : +65-6281-0220
<http://sg.fujitsu.com/semiconductor/>

Europe

FUJITSU SEMICONDUCTOR EUROPE GmbH
Pittlerstrasse 47, 63225 Langen, Germany
Tel: +49-6103-690-0 Fax: +49-6103-690-122
<http://emea.fujitsu.com/semiconductor/>

FUJITSU SEMICONDUCTOR SHANGHAI CO., LTD.

30F, Kerry Parkside, 1155 Fang Dian Road,
Pudong District, Shanghai 201204, China
Tel : +86-21-6146-3688 Fax : +86-21-6146-3660
<http://cn.fujitsu.com/fss/>

Korea

FUJITSU SEMICONDUCTOR KOREA LTD.
902 Kosmo Tower Building, 1002 Daechi-Dong,
Gangnam-Gu, Seoul 135-280, Republic of Korea
Tel: +82-2-3484-7100 Fax: +82-2-3484-7111
<http://kr.fujitsu.com/fsk/>

FUJITSU SEMICONDUCTOR PACIFIC ASIA LTD.

2/F, Green 18 Building, Hong Kong Science Park,
Shatin, N.T., Hong Kong
Tel : +852-2736-3232 Fax : +852-2314-4207
<http://cn.fujitsu.com/fsp/>

Specifications are subject to change without notice. For further information please contact each office.

All Rights Reserved.

The contents of this document are subject to change without notice.

Customers are advised to consult with sales representatives before ordering.

The information, such as descriptions of function and application circuit examples, in this document are presented solely for the purpose of reference to show examples of operations and uses of FUJITSU SEMICONDUCTOR device; FUJITSU SEMICONDUCTOR does not warrant proper operation of the device with respect to use based on such information. When you develop equipment incorporating the device based on such information, you must assume any responsibility arising out of such use of the information.

FUJITSU SEMICONDUCTOR assumes no liability for any damages whatsoever arising out of the use of the information. Any information in this document, including descriptions of function and schematic diagrams, shall not be construed as license of the use or exercise of any intellectual property right, such as patent right or copyright, or any other right of FUJITSU SEMICONDUCTOR or any third party or does FUJITSU SEMICONDUCTOR warrant non-infringement of any third-party's intellectual property right or other right by using such information. FUJITSU SEMICONDUCTOR assumes no liability for any infringement of the intellectual property rights or other rights of third parties which would result from the use of information contained herein.

The products described in this document are designed, developed and manufactured as contemplated for general use, including without limitation, ordinary industrial use, general office use, personal use, and household use, but are not designed, developed and manufactured as contemplated (1) for use accompanying fatal risks or dangers that, unless extremely high safety is secured, could have a serious effect to the public, and could lead directly to death, personal injury, severe physical damage or other loss (i.e., nuclear reaction control in nuclear facility, aircraft flight control, air traffic control, mass transport control, medical life support system, missile launch control in weapon system), or (2) for use requiring extremely high reliability (i.e., submersible repeater and artificial satellite).

Please note that FUJITSU SEMICONDUCTOR will not be liable against you and/or any third party for any claims or damages arising in connection with above-mentioned uses of the products.

Any semiconductor devices have an inherent chance of failure. You must protect against injury, damage or loss from such failures by incorporating safety design measures into your facility and equipment such as redundancy, fire protection, and prevention of over-current levels and other abnormal operating conditions.

Exportation/release of any products described in this document may require necessary procedures in accordance with the regulations of the Foreign Exchange and Foreign Trade Control Law of Japan and/or US export control laws.

The company names and brand names herein are the trademarks or registered trademarks of their respective owners.