

*32-bit ARM™ Cortex™-M3 based Microcontroller*

# FM3 MB9A130N Series

## MB9AF131M/N, MB9AF132M/N

### ■ DESCRIPTION

The MB9A130N Series are highly integrated 32-bit microcontrollers that dedicated for embedded controllers with low-power consumption mode and competitive cost.

The MB9A130N Series are based on the ARM Cortex-M3 Processor with on-chip Flash memory and SRAM, and have peripheral functions such as Motor Control Timers, ADCs, DACs and Communication Interfaces (UART, CSIO, I<sup>2</sup>C).

The products which are described in this data sheet are placed into TYPE7 product categories in " FM3 Family PERIPHERAL MANUAL ".

Note: ARM and Cortex are the trademarks of ARM Limited in the EU and other countries.

**ARM™**

# MB9A130N Series

## ■ FEATURES

- 32-bit ARM Cortex-M3 Core
  - Processor version: r2p1
  - Up to 20MHz Operation Frequency
  - Integrated Nested Vectored Interrupt Controller (NVIC): 1 channel NMI (non-maskable interrupt) and 32 channels' peripheral interrupts and 8 priority levels
  - 24-bit System timer (Sys Tick): System timer for OS task management

- On-chip Memories

[Flash memory]

- Up to 128 Kbytes
- Read cycle: 0 wait-cycle
- Security function for code protection

[SRAM]

This series contains a total of up to 16Kbyte on-chip SRAM memories. This is composed of two independent SRAM (SRAM0, SRAM1) . SRAM0 is connected to I-code bus or D-code bus of Cortex-M3 core. SRAM1 is connected to System bus of Cortex-M3 core.

- SRAM0: None
- SRAM1: Up to 16 Kbytes

- Multi-function Serial Interface (Max 8channels)

Operation mode is selectable from the followings for each channel.

- UART
- CSIO
- I<sup>2</sup>C

[UART]

- Full duplex double buffer
- Selection with or without parity supported
- Built-in dedicated baud rate generator
- External clock available as a serial clock
- Various error detection functions available (parity errors, framing errors, and overrun errors)

[CSIO]

- Full duplex double buffer
- Built-in dedicated baud rate generator
- Overrun error detection function available

[I<sup>2</sup>C]

Standard mode (Max 100kbps) / High-speed mode (Max 400kbps) supported

- A/D Converter (Max 16channels)

[12-bit A/D Converter]

- Successive Approximation type
- Conversion time: Min 1.0μs
- Priority conversion available (priority at 2levels)
- Scanning conversion mode
- Built-in FIFO for conversion data storage (for SCAN conversion: 16steps, for Priority conversion: 4steps)

- D/A Converter (Max 2channels)

- R-2R type
- 10-bit resolution

- **Base Timer (Max 8channels)**

Operation mode is selectable from the followings for each channel.

- 16-bit PWM timer
- 16-bit PPG timer
- 16/32-bit reload timer
- 16/32-bit PWC timer

- **General-Purpose I/O Port**

This series can use its pins as general-purpose I/O ports when they are not used for peripherals. Moreover, the port relocate function is built in. It can set which I/O port the peripheral function can be allocated to.

- Capable of pull-up control per pin
- Capable of reading pin level directly
- Built-in the port relocate function
- Up to 84 high-speed general-purpose I/O Ports @ 100pin Package
- Some ports are 5V tolerant I/O

See "■ LIST OF PIN FUNCTIONS" and "■ I/O CIRCUIT TYPE" to confirm the corresponding pins.

- **Multi-function Timer**

The Multi-function timer is composed of the following blocks.

- 16-bit free-run timer × 3ch.
- Input capture × 4ch.
- Output compare × 6ch.
- A/D activating compare × 3ch.
- Waveform generator × 3ch.
- 16-bit PPG timer × 3ch.  
IGBT mode is contained

The following function can be used to achieve the motor control.

- PWM signal output function
- DC chopper waveform output function
- Dead time function
- Input capture function
- A/D convertor activate function
- DTIF (Motor emergency stop) interrupt function

- **HDMI-CEC/Remote Control Receiver (Up to 2channels)**

- HDMI- CEC receiver / Remote control receiver
  - Operating modes supporting the following standards can be selected
    - SIRCS
    - NEC/Association for Electric Home Appliances
    - HDMI-CEC
  - Capable of adjusting detection timings for start bit and data bit
  - Equipped with noise filter
- HDMI-CEC transmitter
  - Header block automatic transmission by judging Signal free
  - Generating status interrupt by detecting Arbitration lost
  - Generating START, EOM, ACK automatically to output CEC transmission by setting 1 byte data
  - Generating transmission status interrupt when transmitting 1 block (1 byte data and EOM/ACK)

# MB9A130N Series

- **Real-time clock (RTC)**

The Real-time clock can count Year/Month/Day/Hour/Minute/Second/A day of the week from 01 to 99.

- The interrupt function with specifying date and time (Year/Month/Day/Hour/Minute/Second/A day of the week.) is available. This function is also available by specifying only Year, Month, Day, Hour or Minute.
- Timer interrupt function after set time or each set time.
- Capable of rewriting the time with continuing the time count.
- Leap year automatic count is available.

- **External Interrupt Controller Unit**

- Up to 16 external interrupt input pins
- Include one non-maskable interrupt (NMI) input pin

- **Watchdog Timer (2channels)**

A watchdog timer can generate interrupts or a reset when a time-out value is reached.

This series consists of two different watchdogs, a "Hardware" watchdog and a "Software" watchdog.

The "Hardware" watchdog timer is clocked by the built-in low-speed CR oscillator. Therefore, the "Hardware" watchdog is active in any low-power consumption mode except RTC, STOP, Deep standby RTC and Deep standby STOP modes.

- **Clock and Reset**

[Clocks]

Selectable from five clock sources (2 external oscillators, 2 built-in CR oscillators, and Main PLL).

- Main Clock : 4 MHz to 20MHz
- Sub Clock : 32.768kHz
- Built-in high-speed CR Clock : 4MHz
- Built-in low-speed CR Clock : 100kHz
- Main PLL Clock

[Resets]

- Reset requests from INITX pin
- Power-on reset
- Software reset
- Watchdog timers reset
- Low-voltage detection reset
- Clock Super Visor reset

- **Clock Super Visor (CSV)**

Clocks generated by built-in CR oscillators are used to supervise abnormality of the external clocks.

- If external clock failure (clock stop) is detected, reset is asserted.
- If external frequency anomaly is detected, interrupt or reset is asserted.

- **Low-Voltage Detector (LVD)**

This Series includes 2-stage monitoring of voltage on the VCC. When the voltage falls below the voltage that has been set, Low-Voltage Detector generates an interrupt or reset.

- LVD1: error reporting via interrupt
- LVD2: auto-reset operation

- **Low-Power Consumption Mode**

Six low-power consumption modes supported.

- SLEEP
- TIMER
- RTC
- STOP
- Deep standby RTC
- Deep standby STOP

The back up register is 16bytes.

- **Debug**

Serial Wire JTAG Debug Port (SWJ-DP)

- **Power Supply**

Wide range voltage : VCC = 1.8V to 5.5V

# MB9A130N Series

## ■ PRODUCT LINEUP

### • Memory size

Product name		MB9AF131M/N	MB9AF132M/N
On-chip Flash memory		64Kbytes	128Kbytes
On-chip SRAM	SRAM1	12Kbytes	16Kbytes

### • Function

Product name		MB9AF131M MB9AF132M	MB9AF131N MB9AF132N
Pin count		80	100
CPU		Cortex-M3	
Freq.		20MHz	
Power supply voltage range		1.8V to 5.5V	
Multi-function Serial Interface (UART/CSIO/I <sup>2</sup> C)		8ch. (Max)	
Base Timer (PWC/ Reload timer/PWM/PPG)		8ch. (Max)	
MF-Timer	A/D activation compare	3ch.	1 unit (Max)
	Input capture	4ch.	
	Free-run timer	3ch.	
	Output compare	6ch.	
	Waveform generator	3ch.	
	PPG (IGBT mode)	3ch.	
HDMI-CEC/ Remote Control Receiver		2ch. (Max)	
Real-time clock		1 unit	
Watchdog timer		1ch. (SW) + 1ch. (HW)	
External Interrupts		11pins (Max) + NMI × 1	16pins (Max) + NMI × 1
General-purpose I/O ports		67pins (Max)	84pins (Max)
12-bit A/D converter		12ch. (1 unit)	16ch. (1 unit)
10-bit D/A converter		2ch. (Max)	
CSV (Clock Super Visor)		Yes	
LVD (Low-Voltage Detector)		2ch.	
Built-in CR	High-speed	4MHz (± 2%)	
	Low-speed	100kHz (Typ)	
Debug Function		SWJ-DP	

Note: All signals of the peripheral function in each product cannot be allocated by limiting the pins of package. It is necessary to use the port relocate function of the I/O port according to your function use.

# MB9A130N Series

## ■ PACKAGES

Package	Product name	MB9AF131M MB9AF132M	MB9AF131N MB9AF132N
LQFP: FPT-80P-M37 (0.5mm pitch)		○	-
LQFP: FPT-80P-M40 (0.65mm pitch)		○	-
LQFP: FPT-100P-M23 (0.5mm pitch)		-	○
QFP: FPT-100P-M06 (0.65mm pitch)		-	○
BGA: BGA-112P-M04 (0.8mm pitch)		-	planning

○ : Supported

Note : See "■PACKAGE DIMENSIONS" for detailed information on each package.

# MB9A130N Series

## ■ PIN ASSIGNMENT

- FPT-80P-M37/M40

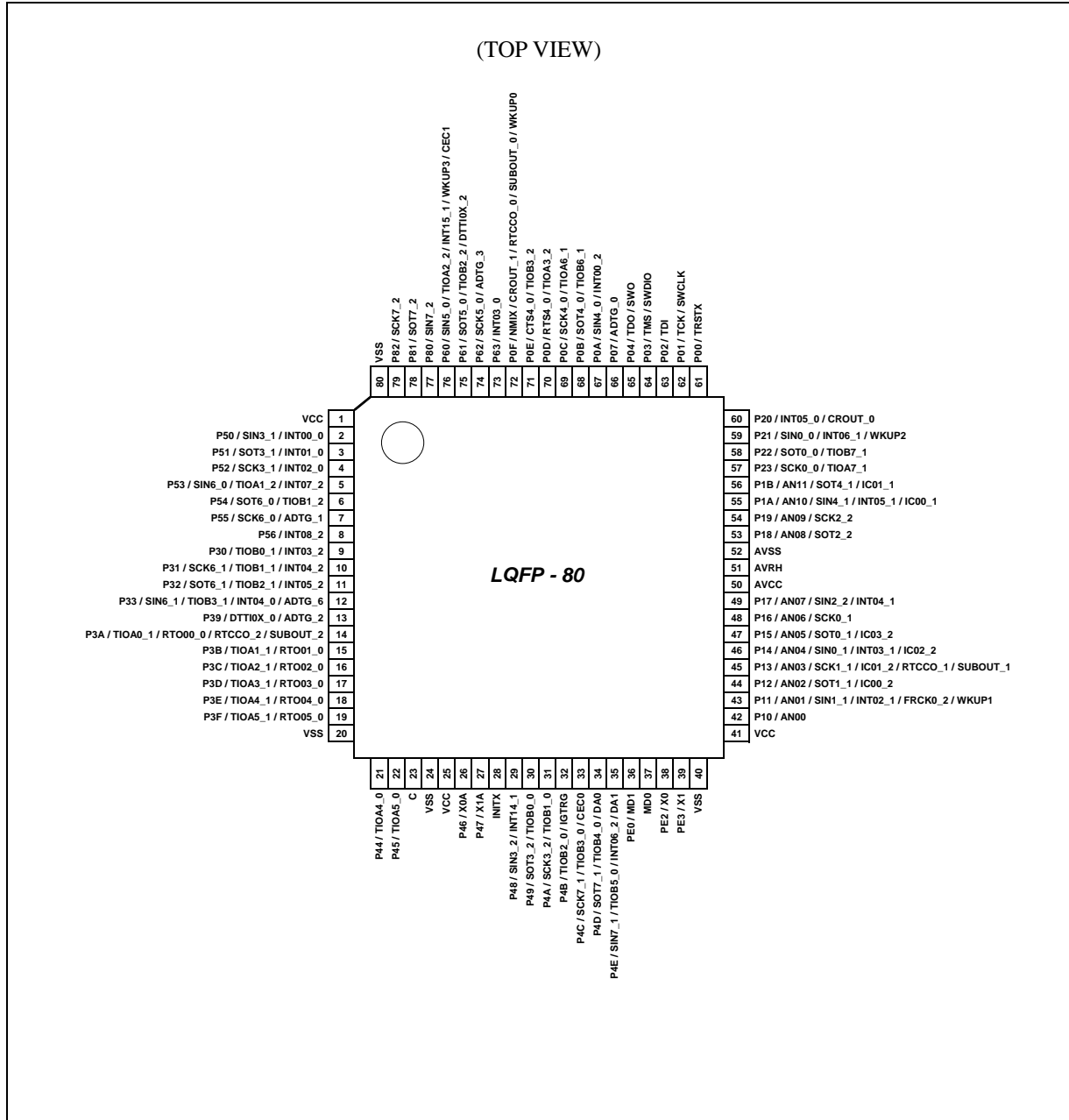

### <Note>

The number after the underscore ("\_") in pin names such as XXX\_1 and XXX\_2 indicates the relocated port number. For these pins, there are multiple pins that provide the same function for the same channel. Use the extended port function register (EPFR) to select the pin.

• FPT-100P-M23

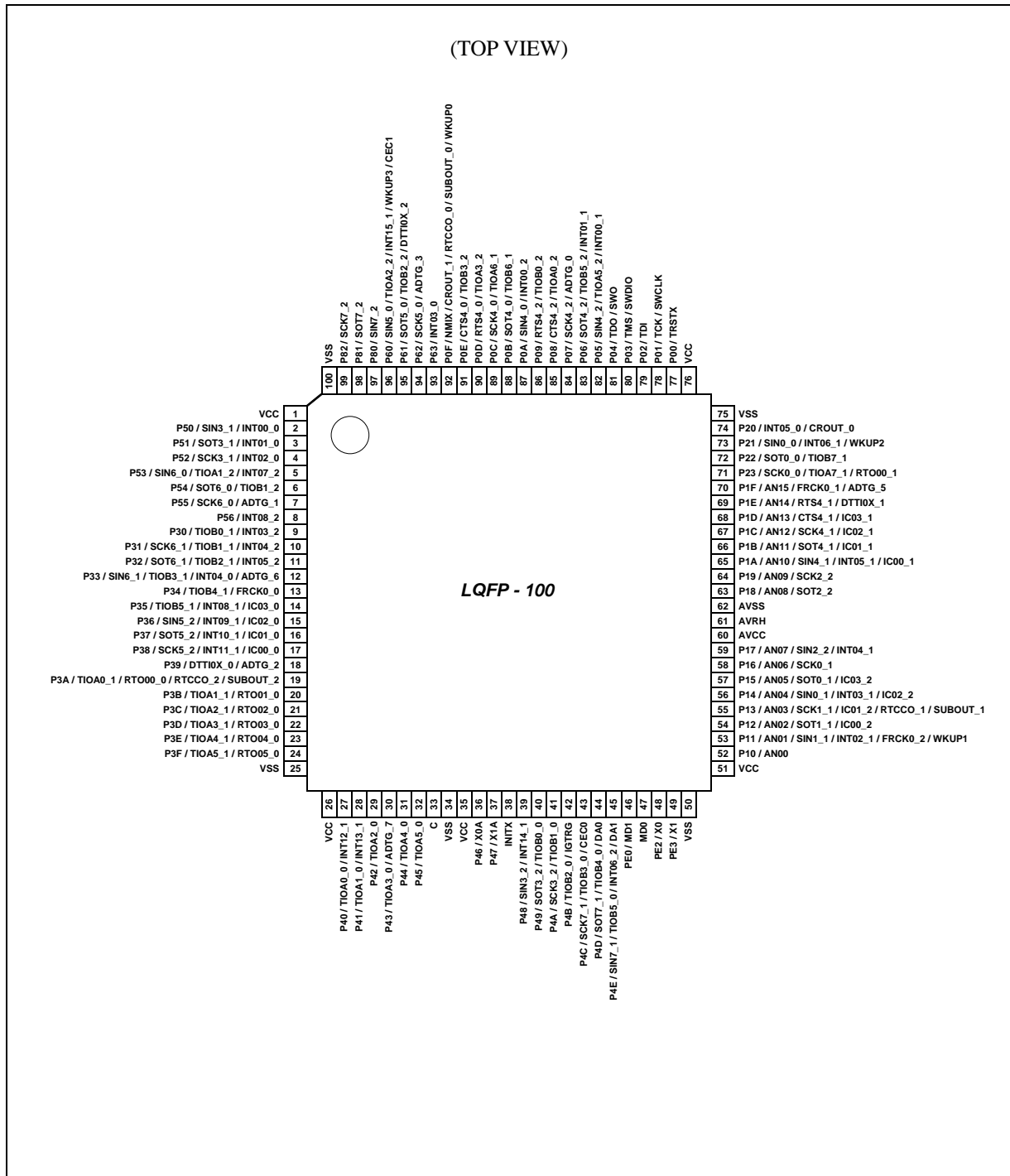

**<Note>**

The number after the underscore ("\_") in pin names such as XXX\_1 and XXX\_2 indicates the relocated port number. For these pins, there are multiple pins that provide the same function for the same channel. Use the extended port function register (EPFR) to select the pin.



# MB9A130N Series

• BGA-112P-M04

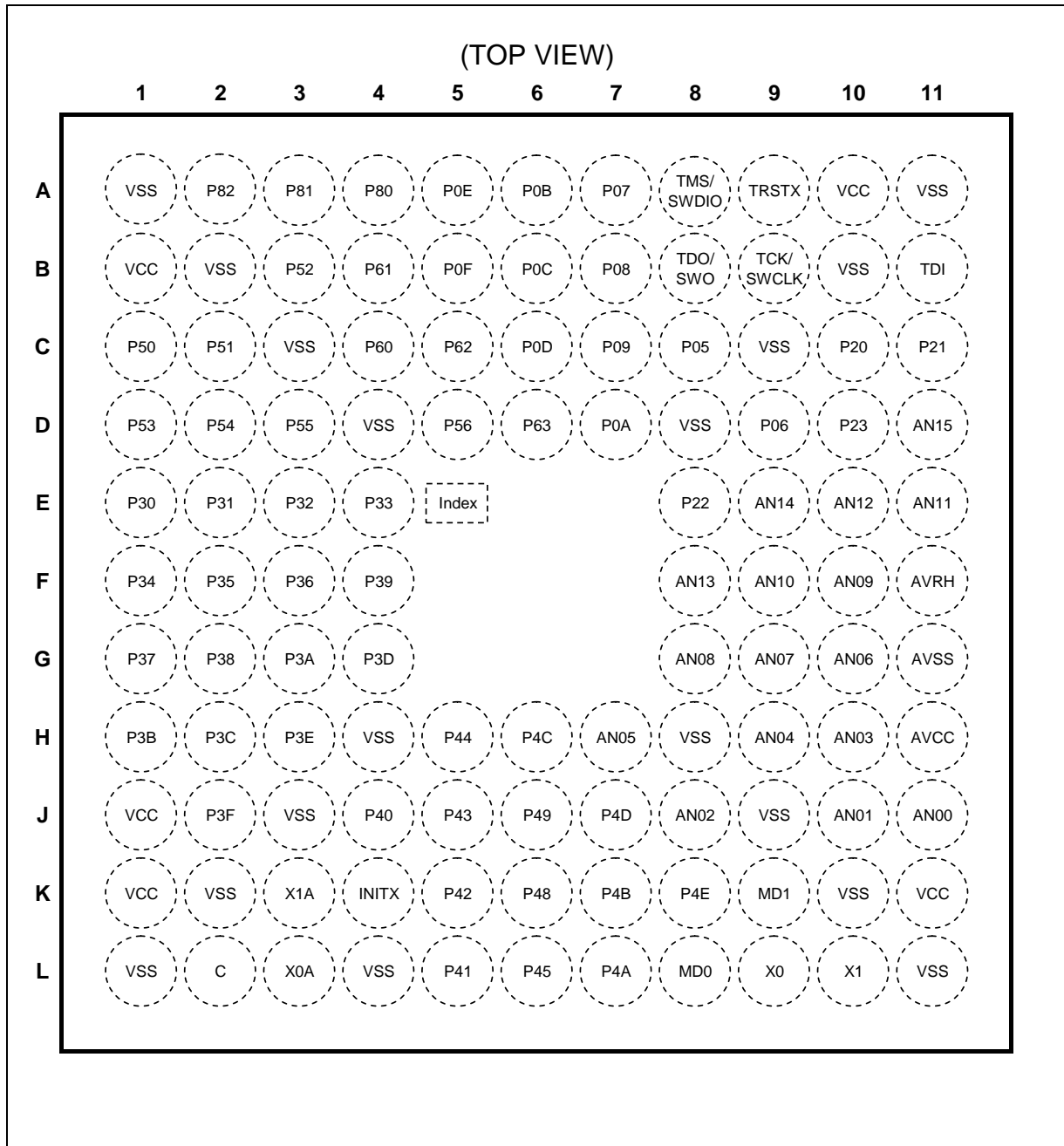

**<Note>**

The number after the underscore ("\_") in pin names such as XXX\_1 and XXX\_2 indicates the relocated port number. For these pins, there are multiple pins that provide the same function for the same channel. Use the extended port function register (EPFR) to select the pin.

# MB9A130N Series

## ■ LIST OF PIN FUNCTIONS

- List of pin numbers

The number after the underscore ("\_") in pin names such as XXX\_1 and XXX\_2 indicates the relocated port number. For these pins, there are multiple pins that provide the same function for the same channel. Use the extended port function register (EPFR) to select the pin.

Pin No				Pin name	I/O circuit type	Pin state type
LQFP-80	LQFP-100	QFP-100	BGA-112			
1	1	79	B1	VCC	-	
2	2	80	C1	P50	E	F
				INT00_0		
				SIN3_1		
3	3	81	C2	P51	E	F
				INT01_0		
				SOT3_1 (SDA3_1)		
4	4	82	B3	P52	E	F
				INT02_0		
				SCK3_1 (SCL3_1)		
5	5	83	D1	P53	E	F
				SIN6_0		
				TIOA1_2 INT07_2		
6	6	84	D2	P54	E	H
				SOT6_0 (SDA6_0)		
				TIOB1_2		
7	7	85	D3	P55	E	H
				SCK6_0 (SCL6_0)		
				ADTG_1		
8	8	86	D5	P56	E	O
				INT08_2		
9	9	87	E1	P30	E	F
				TIOB0_1		
				INT03_2		
10	10	88	E2	P31	E	F
				TIOB1_1		
				SCK6_1 (SCL6_1) INT04_2		
11	11	89	E3	P32	E	F
				TIOB2_1		
				SOT6_1 (SDA6_1)		
				INT05_2		

# MB9A130N Series

Pin No				Pin name	I/O circuit type	Pin state type
LQFP-80	LQFP-100	QFP-100	BGA-112			
12	12	90	E4	P33	E	F
				INT04_0		
				TIOB3_1		
				SIN6_1		
				ADTG_6		
-	13	91	F1	P34	E	H
				FRCK0_0		
				TIOB4_1		
-	14	92	F2	P35	E	F
				IC03_0		
				TIOB5_1		
				INT08_1		
-	15	93	F3	P36	E	F
				IC02_0		
				SIN5_2		
				INT09_1		
-	16	94	G1	P37	E	F
				IC01_0		
				SOT5_2 (SDA5_2)		
				INT10_1		
-	17	95	G2	P38	E	F
				IC00_0		
				SCK5_2 (SCL5_2)		
				INT11_1		
13	18	96	F4	P39	E	H
				DTTIOX_0		
				ADTG_2		
14	19	97	G3	P3A	E	H
				RTO00_0 (PPG00_0)		
				TIOA0_1		
				RTCCO_2		
				SUBOUT_2		
15	20	98	H1	P3B	E	H
				RTO01_0 (PPG00_0)		
				TIOA1_1		
16	21	99	H2	P3C	E	H
				RTO02_0 (PPG02_0)		
				TIOA2_1		

# MB9A130N Series

Pin No				Pin name	I/O circuit type	Pin state type
LQFP-80	LQFP-100	QFP-100	BGA-112			
17	22	100	G4	P3D	E	H
				RTO03_0 (PPG02_0)		
				TIOA3_1		
-	-	-	B2	VSS	-	-
18	23	1	H3	P3E	E	H
				RTO04_0 (PPG04_0)		
				TIOA4_1		
19	24	2	J2	P3F	E	H
				RTO05_0 (PPG04_0)		
				TIOA5_1		
20	25	3	L1	VSS	-	-
-	26	4	J1	VCC	-	-
-	27	5	J4	P40	E	F
				TIOA0_0		
				INT12_1		
-	28	6	L5	P41	E	F
				TIOA1_0		
				INT13_1		
-	29	7	K5	P42	E	H
				TIOA2_0		
-	30	8	J5	P43	E	H
				TIOA3_0		
				ADTG_7		
21	31	9	H5	P44	E	H
22	32	10	L6	TIOA4_0	E	H
				P45		
-	-	-	K2	TIOA5_0	-	-
				VSS		
-	-	-	J3	VSS	-	-
-	-	-	H4	VSS	-	-
23	33	11	L2	C	-	-
24	34	12	L4	VSS	-	-
25	35	13	K1	VCC	-	-
26	36	14	L3	P46	D	M
				X0A		
27	37	15	K3	P47	D	N
				X1A		
28	38	16	K4	INITX	B	C
29	39	17	K6	P48	E	F
				INT14_1		
				SIN3_2		

# MB9A130N Series

Pin No				Pin name	I/O circuit type	Pin state type
LQFP-80	LQFP-100	QFP-100	BGA-112			
30	40	18	J6	P49	E	H
				TIOB0_0		
				SOT3_2 (SDA3_2)		
31	41	19	L7	P4A	E	H
				TIOB1_0		
				SCK3_2 (SCL3_2)		
32	42	20	K7	P4B	E	H
				TIOB2_0		
				IGTRG		
33	43	21	H6	P4C	G	Q
				TIOB3_0		
				SCK7_1 (SCL7_1)		
				CEC0		
34	44	22	J7	P4D	J	T
				TIOB4_0		
				SOT7_1 (SDA7_1)		
				DA0		
35	45	23	K8	P4E	J	S
				TIOB5_0		
				INT06_2		
				SIN7_1		
36	46	24	K9	PE0	C	P
				MD1		
37	47	25	L8	MD0	H	D
38	48	26	L9	PE2	A	A
				X0		
39	49	27	L10	PE3	A	B
				X1		
40	50	28	L11	VSS	-	
41	51	29	K11	VCC	-	
42	52	30	J11	P10	F	J
				AN00		
43	53	31	J10	P11	F	L
				AN01		
				SIN1_1		
				INT02_1		
				FRCK0_2		
WKUP1						

# MB9A130N Series

Pin No				Pin name	I/O circuit type	Pin state type
LQFP-80	LQFP-100	QFP-100	BGA-112			
44	54	32	J8	P12	F	J
				AN02		
				SOT1_1 (SDA1_1)		
				IC00_2		
-	-	-	K10	VSS	-	-
-	-	-	J9	VSS	-	-
45	55	33	H10	P13	F	J
				AN03		
				SCK1_1 (SCL1_1)		
				IC01_2		
				RTCCO_1 SUBOUT_1		
46	56	34	H9	P14	F	K
				AN04		
				SIN0_1		
				INT03_1 IC02_2		
47	57	35	H7	P15	F	J
				AN05		
				SOT0_1		
				IC03_2		
48	58	36	G10	P16	F	J
				AN06		
				SCK0_1 (SCL0_1)		
49	59	37	G9	P17	F	K
				AN07		
				SIN2_2 INT04_1		
50	60	38	H11	AVCC	-	-
51	61	39	F11	AVRH	-	-
52	62	40	G11	AVSS	-	-
53	63	41	G8	P18	F	J
				AN08		
				SOT2_2 (SDA2_2)		
54	64	42	F10	P19	F	J
				AN09		
				SCK2_2 (SCL2_2)		
-	-	-	H8	VSS	-	-

# MB9A130N Series

Pin No				Pin name	I/O circuit type	Pin state type
LQFP-80	LQFP-100	QFP-100	BGA-112			
55	65	43	F9	P1A	F	K
				AN10		
				SIN4_1		
				INT05_1		
				IC00_1		
56	66	44	E11	P1B	F	J
				AN11		
				SOT4_1 (SDA4_1)		
				IC01_1		
-	67	45	E10	P1C	F	J
				AN12		
				SCK4_1 (SCL4_1)		
				IC02_1		
-	68	46	F8	P1D	F	J
				AN13		
				CTS4_1		
				IC03_1		
-	69	47	E9	P1E	F	J
				AN14		
				RTS4_1		
				DTTIOX_1		
-	70	48	D11	P1F	F	J
				AN15		
				ADTG_5		
				FRCK0_1		
-	-	-	B10	VSS	-	-
-	-	-	C9	VSS	-	-
57	71	49	D10	P23	E	H
				SCK0_0 (SCL0_0)		
				TIOA7_1		
				RTO00_1		
-						
58	72	50	E8	P22	E	H
				SOT0_0 (SDA0_0)		
				TIOB7_1		
59	73	51	C11	P21	E	G
				SIN0_0		
				INT06_1		
				WKUP2		
60	74	52	C10	P20	E	F
				INT05_0		
				CROUT_0		

# MB9A130N Series

Pin No				Pin name	I/O circuit type	Pin state type
LQFP-80	LQFP-100	QFP-100	BGA-112			
-	75	53	A11	VSS	-	
-	76	54	A10	VCC	-	
61	77	55	A9	P00	E	E
				TRSTX		
62	78	56	B9	P01	E	E
				TCK		
				SWCLK		
63	79	57	B11	P02	E	E
				TDI		
64	80	58	A8	P03	E	E
				TMS		
				SWDIO		
65	81	59	B8	P04	E	E
				TDO		
				SWO		
-	82	60	C8	P05	E	F
				TIOA5_2		
				SIN4_2		
				INT00_1		
-	-	-	D8	VSS	-	
-	83	61	D9	P06	E	F
				TIOB5_2		
				SOT4_2 (SDA4_2)		
				INT01_1		
66	84	62	A7	P07	E	H
-				ADTG_0		
-	85	63	B7	SCK4_2 (SCL4_2)	E	H
-				P08		
-				TIOA0_2		
-	86	64	C7	CTS4_2	E	H
-				P09		
-				TIOB0_2		
67	87	65	D7	RTS4_2	G	F
-				P0A		
-				SIN4_0		
68	88	66	A6	INT00_2	G	H
-				P0B		
-	89	67	B6	SOT4_0 (SDA4_0)	G	H
-				TIOB6_1		
-				P0C		
69	89	67	B6	SCK4_0 (SCL4_0)	G	H
-				TIOA6_1		

# MB9A130N Series

Pin No				Pin name	I/O circuit type	Pin state type
LQFP-80	LQFP-100	QFP-100	BGA-112			
-	-	-	D4	VSS	-	-
-	-	-	C3	VSS	-	-
70	90	68	C6	P0D	E	H
				RTS4_0		
				TIOA3_2		
71	91	69	A5	P0E	E	H
				CTS4_0		
				TIOB3_2		
72	92	70	B5	P0F	E	I
				NMIX		
				CROUT_1		
				RTCCO_0		
				SUBOUT_0		
				WKUP0		
73	93	71	D6	P63	E	O
				INT03_0		
74	94	72	C5	P62	E	H
				SCK5_0 (SCL5_0)		
				ADTG_3		
75	95	73	B4	P61	E	H
				SOT5_0 (SDA5_0)		
				TIOB2_2		
				DTTIOX_2		
76	96	74	C4	P60	G	R
				SIN5_0		
				TIOA2_2		
				INT15_1		
				WKUP3		
				CEC1		
77	97	75	A4	P80	G	H
				SIN7_2		
78	98	76	A3	P81	G	H
				SOT7_2		
79	99	77	A2	P82	G	H
				SCK7_2		
80	100	78	A1	VSS	-	-

# MB9A130N Series

- List of pin functions

The number after the underscore ("\_") in pin names such as XXX\_1 and XXX\_2 indicates the relocated port number. For these pins, there are multiple pins that provide the same function for the same channel. Use the extended port function register (EPFR) to select the pin.

Pin function	Pin name	Function description	Pin No			
			LQFP-80	LQFP-100	QFP-100	BGA-112
ADC	ADTG_0	A/D converter external trigger input pin	66	84	62	A7
	ADTG_1		7	7	85	D3
	ADTG_2		13	18	96	F4
	ADTG_3		74	94	72	C5
	ADTG_4		-	-	-	-
	ADTG_5		-	70	48	D11
	ADTG_6		12	12	90	E4
	ADTG_7		-	30	8	J5
	ADTG_8		-	-	-	-
	AN00	A/D converter analog input pin. ANxx describes ADC ch.xx.	42	52	30	J11
	AN01		43	53	31	J10
	AN02		44	54	32	J8
	AN03		45	55	33	H10
	AN04		46	56	34	H9
	AN05		47	57	35	H7
	AN06		48	58	36	G10
	AN07		49	59	37	G9
	AN08		53	63	41	G8
	AN09		54	64	42	F10
	AN10		55	65	43	F9
	AN11		56	66	44	E11
	AN12		-	67	45	E10
	AN13		-	68	46	F8
	AN14		-	69	47	E9
	AN15		-	70	48	D11

# MB9A130N Series

Pin function	Pin name	Function description	Pin No			
			LQFP-80	LQFP-100	QFP-100	BGA-112
Base Timer 0	TIOA0_0	Base timer ch.0 TIOA pin	-	27	5	J4
	TIOA0_1		14	19	97	G3
	TIOA0_2		-	85	63	B7
	TIOB0_0	Base timer ch.0 TIOB pin	30	40	18	J6
	TIOB0_1		9	9	87	E1
	TIOB0_2		-	86	64	C7
Base Timer 1	TIOA1_0	Base timer ch.1 TIOA pin	-	28	6	L5
	TIOA1_1		15	20	98	H1
	TIOA1_2		5	5	83	D1
	TIOB1_0	Base timer ch.1 TIOB pin	31	41	19	L7
	TIOB1_1		10	10	88	E2
	TIOB1_2		6	6	84	D2
Base Timer 2	TIOA2_0	Base timer ch.2 TIOA pin	-	29	7	K5
	TIOA2_1		16	21	99	H2
	TIOA2_2		76	96	74	C4
	TIOB2_0	Base timer ch.2 TIOB pin	32	42	20	K7
	TIOB2_1		11	11	89	E3
	TIOB2_2		75	95	73	B4
Base Timer 3	TIOA3_0	Base timer ch.3 TIOA pin	-	30	8	J5
	TIOA3_1		17	22	100	G4
	TIOA3_2		70	90	68	C6
	TIOB3_0	Base timer ch.3 TIOB pin	33	43	21	H6
	TIOB3_1		12	12	90	E4
	TIOB3_2		71	91	69	A5
Base Timer 4	TIOA4_0	Base timer ch.4 TIOA pin	21	31	9	H5
	TIOA4_1		18	23	1	H3
	TIOA4_2		-	-	-	-
	TIOB4_0	Base timer ch.4 TIOB pin	34	44	22	J7
	TIOB4_1		-	13	91	F1
	TIOB4_2		-	-	-	-
Base Timer 5	TIOA5_0	Base timer ch.5 TIOA pin	22	32	10	L6
	TIOA5_1		19	24	2	J2
	TIOA5_2		-	82	60	C8
	TIOB5_0	Base timer ch.5 TIOB pin	35	45	23	K8
	TIOB5_1		-	14	92	F2
	TIOB5_2		-	83	61	D9
Base Timer 6	TIOA6_1	Base timer ch.6 TIOA pin	69	89	67	B6
	TIOB6_1	Base timer ch.6 TIOB pin	68	88	66	A6
Base Timer 7	TIOA7_0	Base timer ch.7 TIOA pin	-	-	-	-
	TIOA7_1		57	71	49	D10
	TIOA7_2		-	-	-	-
	TIOB7_0	Base timer ch.7 TIOB pin	-	-	-	-
	TIOB7_1		58	72	50	E8
	TIOB7_2		-	-	-	-

# MB9A130N Series

Pin function	Pin name	Function description	Pin No			
			LQFP-80	LQFP-100	QFP-100	BGA-112
Debugger	SWCLK	Serial wire debug interface clock input pin	62	78	56	B9
	SWDIO	Serial wire debug interface data input / output pin	64	80	58	A8
	SWO	Serial wire viewer output pin	65	81	59	B8
	TRSTX	J-TAG reset input pin	61	77	55	A9
	TCK	J-TAG test clock input pin	62	78	56	B9
	TDI	J-TAG test data input pin	63	79	57	B11
	TMS	J-TAG test mode state input/output pin	64	80	58	A8
	TDO	J-TAG debug data output pin	65	81	59	B8
External Interrupt	INT00_0	External interrupt request 00 input pin	2	2	80	C1
	INT00_1		-	82	60	C8
	INT00_2		67	87	65	D7
	INT01_0	External interrupt request 01 input pin	3	3	81	C2
	INT01_1		-	83	61	D9
	INT02_0		External interrupt request 02 input pin	4	4	82
	INT02_1	43		53	31	J10
	INT03_0	External interrupt request 03 input pin	73	93	71	D6
	INT03_1		46	56	34	H9
	INT03_2		9	9	87	E1
	INT04_0	External interrupt request 04 input pin	12	12	90	E4
	INT04_1		49	59	37	G9
	INT04_2		10	10	88	E2
	INT05_0	External interrupt request 05 input pin	60	74	52	C10
	INT05_1		55	65	43	F9
	INT05_2		11	11	89	E3
	INT06_1	External interrupt request 06 input pin	59	73	51	C11
	INT06_2		35	45	23	K8
	INT07_2	External interrupt request 07 input pin	5	5	83	D1
	INT08_1	External interrupt request 08 input pin	-	14	92	F2
	INT08_2		8	8	86	D5
	INT09_1	External interrupt request 09 input pin	-	15	93	F3
	INT10_1	External interrupt request 10 input pin	-	16	94	G1
	INT11_1	External interrupt request 11 input pin	-	17	95	G2
	INT12_1	External interrupt request 12 input pin	-	27	5	J4
	INT13_1	External interrupt request 13 input pin	-	28	6	L5
	INT14_1	External interrupt request 14 input pin	29	39	17	K6
	INT15_1	External interrupt request 15 input pin	76	96	74	C4
	NMIX	Non-Maskable Interrupt input pin	72	92	70	B5

# MB9A130N Series

Pin function	Pin name	Function description	Pin No			
			LQFP-80	LQFP-100	QFP-100	BGA-112
GPIO	P00	General-purpose I/O port 0	61	77	55	A9
	P01		62	78	56	B9
	P02		63	79	57	B11
	P03		64	80	58	A8
	P04		65	81	59	B8
	P05		-	82	60	C8
	P06		-	83	61	D9
	P07		66	84	62	A7
	P08		-	85	63	B7
	P09		-	86	64	C7
	P0A		67	87	65	D7
	P0B		68	88	66	A6
	P0C		69	89	67	B6
	P0D		70	90	68	C6
	P0E		71	91	69	A5
	P0F		72	92	70	B5
	P10		42	52	30	J11
	P11	43	53	31	J10	
	P12	44	54	32	J8	
	P13	45	55	33	H10	
	P14	46	56	34	H9	
	P15	47	57	35	H7	
	P16	48	58	36	G10	
	P17	49	59	37	G9	
	P18	53	63	41	G8	
	P19	54	64	42	F10	
	P1A	55	65	43	F9	
	P1B	56	66	44	E11	
	P1C	-	67	45	E10	
	P1D	-	68	46	F8	
	P1E	-	69	47	E9	
	P1F	-	70	48	D11	
	P20	60	74	52	C10	
P21	59	73	51	C11		
P22	58	72	50	E8		
P23	57	71	49	D10		

# MB9A130N Series

Pin function	Pin name	Function description	Pin No			
			LQFP-80	LQFP-100	QFP-100	BGA-112
GPIO	P30	General-purpose I/O port 3	9	9	87	E1
	P31		10	10	88	E2
	P32		11	11	89	E3
	P33		12	12	90	E4
	P34		-	13	91	F1
	P35		-	14	92	F2
	P36		-	15	93	F3
	P37		-	16	94	G1
	P38		-	17	95	G2
	P39		13	18	96	F4
	P3A		14	19	97	G3
	P3B		15	20	98	H1
	P3C		16	21	99	H2
	P3D		17	22	100	G4
	P3E		18	23	1	H3
	P3F		19	24	2	J2
	P40		-	27	5	J4
	P41		-	28	6	L5
	P42		-	29	7	K5
	P43	-	30	8	J5	
	P44	21	31	9	H5	
	P45	22	32	10	L6	
	P46	26	36	14	L3	
	P47	27	37	15	K3	
	P48	29	39	17	K6	
	P49	30	40	18	J6	
	P4A	31	41	19	L7	
	P4B	32	42	20	K7	
	P4C	33	43	21	H6	
	P4D	34	44	22	J7	
	P4E	35	45	23	K8	
	P50	2	General-purpose I/O port 5	2	80	C1
	P51	3		3	81	C2
	P52	4		4	82	B3
	P53	5		5	83	D1
	P54	6		6	84	D2
	P55	7		7	85	D3
	P56	8		8	86	D5
	P60	76		96	74	C4
	P61	75	95	73	B4	
	P62	74	94	72	C5	
	P63	73	93	71	D6	
P80	77	97	75	A4		
P81	78	98	76	A3		
P82	79	99	77	A2		
PE0	36	46	24	K9		
PE2	38	48	26	L9		
PE3	39	49	27	L10		

# MB9A130N Series

Pin function	Pin name	Function description	Pin No			
			LQFP-80	LQFP-100	QFP-100	BGA-112
Multi-function Serial 0	SIN0_0	Multi-function serial interface ch.0 input pin	59	73	51	C11
	SIN0_1		46	56	34	H9
	SOT0_0 (SDA0_0)	Multi-function serial interface ch.0 output pin. This pin operates as SOT0 when it is used in a UART/CSIO (operation modes 0 to 2) and as SDA0 when it is used in an I <sup>2</sup> C (operation mode 4).	58	72	50	E8
	SOT0_1 (SDA0_1)		47	57	35	H7
	SCK0_0 (SCL0_0)	Multi-function serial interface ch.0 clock I/O pin. This pin operates as SCK0 when it is used in a UART/CSIO (operation modes 0 to 2) and as SCL0 when it is used in an I <sup>2</sup> C (operation mode 4).	57	71	49	D10
	SCK0_1 (SCL0_1)		48	58	36	G10
Multi-function Serial 1	SIN1_1	Multi-function serial interface ch.1 input pin	43	53	31	J10
	SOT1_1 (SDA1_1)	Multi-function serial interface ch.1 output pin. This pin operates as SOT1 when it is used in a UART/CSIO (operation modes 0 to 2) and as SDA1 when it is used in an I <sup>2</sup> C (operation mode 4).	44	54	32	J8
	SCK1_1 (SCL1_1)	Multi-function serial interface ch.1 clock I/O pin. This pin operates as SCK1 when it is used in a UART/CSIO (operation modes 0 to 2) and as SCL1 when it is used in an I <sup>2</sup> C (operation mode 4).	45	55	33	H10
Multi-function Serial 2	SIN2_2	Multi-function serial interface ch.2 input pin	49	59	37	G9
	SOT2_2 (SDA2_2)	Multi-function serial interface ch.2 output pin. This pin operates as SOT2 when it is used in a UART/CSIO (operation modes 0 to 2) and as SDA2 when it is used in an I <sup>2</sup> C (operation mode 4).	53	63	41	G8
	SCK2_2 (SCL2_2)	Multi-function serial interface ch.2 clock I/O pin. This pin operates as SCK2 when it is used in a UART/CSIO (operation modes 0 to 2) and as SCL2 when it is used in an I <sup>2</sup> C (operation mode 4).	54	64	42	F10

# MB9A130N Series

Pin function	Pin name	Function description	Pin No			
			LQFP-80	LQFP-100	QFP-100	BGA-112
Multi-function Serial 3	SIN3_1	Multi-function serial interface ch.3 input pin	2	2	80	C1
	SIN3_2		29	39	17	K6
	SOT3_1 (SDA3_1)	Multi-function serial interface ch.3 output pin. This pin operates as SOT3 when it is used in a UART/CSIO (operation modes 0 to 2) and as SDA3 when it is used in an I <sup>2</sup> C (operation mode 4).	3	3	81	C2
	SOT3_2 (SDA3_2)		30	40	18	J6
	SCK3_1 (SCL3_1)	Multi-function serial interface ch.3 clock I/O pin. This pin operates as SCK3 when it is used in a UART/CSIO (operation modes 0 to 2) and as SCL3 when it is used in an I <sup>2</sup> C (operation mode 4).	4	4	82	B3
	SCK3_2 (SCL3_2)		31	41	19	L7
Multi-function Serial 4	SIN4_0	Multi-function serial interface ch.4 input pin	67	87	65	D7
	SIN4_1		55	65	43	F9
	SIN4_2		-	82	60	C8
	SOT4_0 (SDA4_0)	Multi-function serial interface ch.4 output pin. This pin operates as SOT4 when it is used in a UART/CSIO (operation modes 0 to 2) and as SDA4 when it is used in an I <sup>2</sup> C (operation mode 4).	68	88	66	A6
	SOT4_1 (SDA4_1)		56	66	44	E11
	SOT4_2 (SDA4_2)		-	83	61	D9
	SCK4_0 (SCL4_0)	Multi-function serial interface ch.4 clock I/O pin. This pin operates as SCK4 when it is used in a UART/CSIO (operation modes 0 to 2) and as SCL4 when it is used in an I <sup>2</sup> C (operation mode 4).	69	89	67	B6
	SCK4_1 (SCL4_1)		-	67	45	E10
	SCK4_2 (SCL4_2)		-	84	62	A7
	RTS4_0	Multi-function serial interface ch.4 RTS output pin	70	90	68	C6
	RTS4_1		-	69	47	E9
	RTS4_2		-	86	64	C7
	CTS4_0	Multi-function serial interface ch.4 CTS input pin	71	91	69	A5
	CTS4_1		-	68	46	F8
	CTS4_2		-	85	63	B7

# MB9A130N Series

Pin function	Pin name	Function description	Pin No			
			LQFP-80	LQFP-100	QFP-100	BGA-112
Multi-function Serial 5	SIN5_0	Multi-function serial interface ch.5 input pin	76	96	74	C4
	SIN5_2		-	15	93	F3
	SOT5_0 (SDA5_0)	Multi-function serial interface ch.5 output pin. This pin operates as SOT5 when it is used in a UART/CSIO (operation modes 0 to 2) and as SDA5 when it is used in an I <sup>2</sup> C (operation mode 4).	75	95	73	B4
	SOT5_2 (SDA5_2)		-	16	94	G1
	SCK5_0 (SCL5_0)	Multi-function serial interface ch.5 clock I/O pin. This pin operates as SCK5 when it is used in a UART/CSIO (operation modes 0 to 2) and as SCL5 when it is used in an I <sup>2</sup> C (operation mode 4).	74	94	72	C5
	SCK5_2 (SCL5_2)		-	17	95	G2
Multi-function Serial 6	SIN6_0	Multi-function serial interface ch.6 input pin	5	5	83	D1
	SIN6_1		12	12	90	E4
	SOT6_0 (SDA6_0)	Multi-function serial interface ch.6 output pin. This pin operates as SOT6 when it is used in a UART/CSIO (operation modes 0 to 2) and as SDA6 when it is used in an I <sup>2</sup> C (operation mode 4).	6	6	84	D2
	SOT6_1 (SDA6_1)		11	11	89	E3
	SCK6_0 (SCL6_0)	Multi-function serial interface ch.6 clock I/O pin. This pin operates as SCK6 when it is used in a UART/CSIO (operation modes 0 to 2) and as SCL6 when it is used in an I <sup>2</sup> C (operation mode 4).	7	7	85	D3
	SCK6_1 (SCL6_1)		10	10	88	E2
Multi-function Serial 7	SIN7_1	Multi-function serial interface ch.7 input pin	35	45	23	K8
	SIN7_2		77	97	75	A4
	SOT7_1 (SDA7_1)	Multi-function serial interface ch.7 output pin. This pin operates as SOT7 when it is used in a UART/CSIO (operation modes 0 to 2) and as SDA7 when it is used in an I <sup>2</sup> C (operation mode 4).	34	44	22	J7
	SOT7_2 (SDA7_2)		78	98	76	A3
	SCK7_1 (SCL7_1)	Multi-function serial interface ch.7 clock I/O pin. This pin operates as SCK7 when it is used in a UART/CSIO (operation modes 0 to 2) and as SCL7 when it is used in an I <sup>2</sup> C (operation mode 4).	33	43	21	H6
	SCK7_2 (SCL7_2)		79	99	77	A2

# MB9A130N Series

Pin function	Pin name	Function description	Pin No				
			LQFP-80	LQFP-100	QFP-100	BGA-112	
Multi-function Timer 0	DTTIOX_0	Input signal of waveform generator to control outputs RTO00 to RTO05 of Multi-function timer 0	13	18	96	F4	
	DTTIOX_1		-	69	47	E9	
	DTTIOX_2		75	95	73	B4	
	FRCK0_0	16-bit free-run timer ch.0 external clock input pin	-	13	91	F1	
	FRCK0_1		-	70	48	D11	
	FRCK0_2		43	53	31	J10	
	IC00_0	16-bit input capture input pin of Multi-function timer 0. ICxx describes a channel number.	-	17	95	G2	
	IC00_1		55	65	43	F9	
	IC00_2		44	54	32	J8	
	IC01_0		-	16	94	G1	
	IC01_1		56	66	44	E11	
	IC01_2		45	55	33	H10	
	IC02_0		-	15	93	F3	
	IC02_1		-	67	45	E10	
	IC02_2		46	56	34	H9	
	IC03_0		-	14	92	F2	
	IC03_1		-	68	46	F8	
	IC03_2		47	57	35	H7	
	RTO00_0 (PPG00_0)		Waveform generator output pin of Multi-function timer 0.	14	19	97	G3
	RTO00_1 (PPG00_1)		This pin operates as PPG00 when it is used in PPG0 output mode.	-	71	49	D10
	RTO01_0 (PPG00_0)		Waveform generator output pin of Multi-function timer 0. This pin operates as PPG00 when it is used in PPG0 output mode.	15	20	98	H1
	RTO02_0 (PPG02_0)	Waveform generator output pin of Multi-function timer 0. This pin operates as PPG02 when it is used in PPG0 output mode.	16	21	99	H2	
	RTO03_0 (PPG02_0)	Waveform generator output pin of Multi-function timer 0. This pin operates as PPG02 when it is used in PPG0 output mode.	17	22	100	G4	
RTO04_0 (PPG04_0)	Waveform generator output pin of Multi-function timer 0. This pin operates as PPG04 when it is used in PPG0 output mode.	18	23	1	H3		
RTO05_0 (PPG04_0)	Waveform generator output pin of Multi-function timer 0. This pin operates as PPG04 when it is used in PPG0 output mode.	19	24	2	J2		
IGTRG	PPG IGBT mode external trigger input pin	32	42	20	K7		

# MB9A130N Series

Pin function	Pin name	Function description	Pin No			
			LQFP-80	LQFP-100	QFP-100	BGA-112
Real-time clock	RTCCO_0	Pulse output pin of Real-time clock	72	92	70	B5
	RTCCO_1		45	55	33	H10
	RTCCO_2		14	19	97	G3
	SUBOUT_0	Sub clock output pin	72	92	70	B5
	SUBOUT_1		45	55	33	H10
	SUBOUT_2		14	19	97	G3
Low-Power Consumption Mode	WKUP0	Deep standby mode return signal input pin 0	72	92	70	B5
	WKUP1	Deep standby mode return signal input pin 1	43	53	31	J10
	WKUP2	Deep standby mode return signal input pin 2	59	73	51	C11
	WKUP3	Deep standby mode return signal input pin 3	76	96	74	C4
DAC	DA0	D/A converter ch.0 analog output pin	34	44	22	J7
	DA1	D/A converter ch.1 analog output pin	35	45	23	K8
HDMI-CEC	CEC0	HDMI-CEC ch.0 pin	33	43	21	H6
	CEC1	HDMI-CEC ch.1 pin	76	96	74	C4

# MB9A130N Series

Pin function	Pin name	Function description	Pin No			
			LQFP-80	LQFP-100	QFP-100	BGA-112
RESET	INITX	External Reset Input Pin. A reset is valid when INITX = "L".	28	38	16	K4
Mode	MD0	Mode 0 pin. During normal operation, MD0 = "L" must be input. During serial programming to Flash memory, MD0 = "H" must be input.	37	47	25	L8
	MD1	Mode 1 pin. During normal operation, input is not needed. During serial programming to Flash memory, MD1 = "L" must be input.	36	46	24	K9
POWER	VCC	Power supply pin	1	1	79	B1
			-	26	4	J1
			25	35	13	K1
			41	51	29	K11
			-	76	54	A10
GND	VSS	GND pin	-	-	-	B2
			20	25	3	L1
			-	-	-	K2
			-	-	-	J3
			-	-	-	H4
			24	34	12	L4
			40	50	28	L11
			-	-	-	K10
			-	-	-	J9
			-	-	-	H8
			-	-	-	B10
			-	-	-	C9
			-	75	53	A11
			-	-	-	D8
			-	-	-	D4
			-	-	-	C3
			-	80	100	78
CLOCK	X0	Main clock (oscillation) input pin	38	48	26	L9
	X0A	Sub clock (oscillation) input pin	26	36	14	L3
	X1	Main clock (oscillation) I/O pin	39	49	27	L10
	X1A	Sub clock (oscillation) I/O pin	27	37	15	K3
	CROUT_0	Built-in high-speed CR-osc clock output port	60	74	52	C10
	CROUT_1		72	92	70	B5
Analog POWER	AVCC	A/D converter and D/A converter analog power supply pin	50	60	38	H11
	AVRH	A/D converter analog reference voltage input pin	51	61	39	F11
Analog GND	AVSS	A/D converter and D/A converter GND pin	52	62	40	G11
C pin	C	Power supply stabilization capacity pin	23	33	11	L2

## ■ I/O CIRCUIT TYPE

Type	Circuit	Remarks
A		<p>It is possible to select the main oscillation / GPIO function.</p> <p>When the main oscillation is selected.</p> <ul style="list-style-type: none"> <li>• Oscillation feedback resistor : Approximately 1MΩ</li> <li>• With standby mode control</li> </ul> <p>When the GPIO is selected.</p> <ul style="list-style-type: none"> <li>• CMOS level output.</li> <li>• CMOS level hysteresis input</li> <li>• With pull-up resistor control</li> <li>• With standby mode control</li> <li>• Pull-up resistor : Approximately 50kΩ</li> <li>• <math>I_{OH} = -4mA, I_{OL} = 4mA</math></li> </ul>
B		<ul style="list-style-type: none"> <li>• CMOS level hysteresis input</li> <li>• Pull-up resistor : Approximately 50kΩ</li> </ul>

# MB9A130N Series

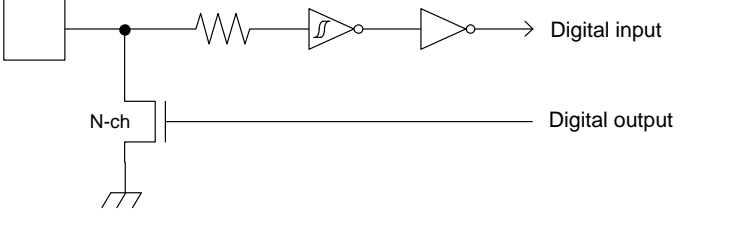
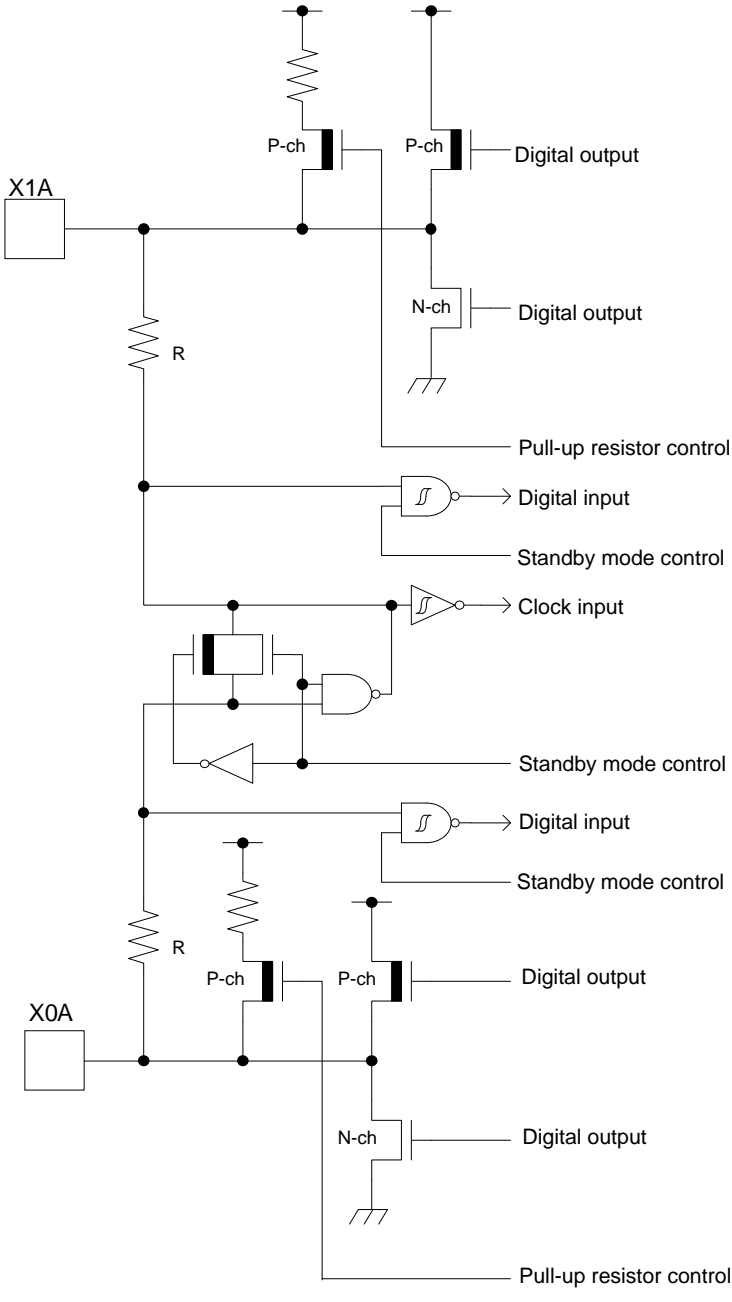
Type	Circuit	Remarks
C		<ul style="list-style-type: none"> <li>• Open drain output</li> <li>• CMOS level hysteresis input</li> </ul>
D		<p>It is possible to select the sub oscillation / GPIO function</p> <p>When the sub oscillation is selected.</p> <ul style="list-style-type: none"> <li>• Oscillation feedback resistor : Approximately 5MΩ</li> <li>• With standby mode control</li> </ul> <p>When the GPIO is selected.</p> <ul style="list-style-type: none"> <li>• CMOS level output.</li> <li>• CMOS level hysteresis input</li> <li>• With pull-up resistor control</li> <li>• With standby mode control</li> <li>• Pull-up resistor : Approximately 50kΩ</li> <li>• <math>I_{OH} = -4mA</math>, <math>I_{OL} = 4mA</math></li> </ul>

Type	Circuit	Remarks
E	<p>The circuit diagram for Type E shows a CMOS output stage. It consists of a P-channel MOSFET (P-ch) and an N-channel MOSFET (N-ch) connected in a push-pull configuration. The gates of both MOSFETs are connected to a common input node. This node is pulled up to V<sub>DD</sub> by a resistor R. The input node is also connected to a digital input signal through an inverter. A standby mode control signal is connected to the gates of both MOSFETs. The output of the P-ch MOSFET is labeled 'Digital output'.</p>	<ul style="list-style-type: none"> <li>• CMOS level output</li> <li>• CMOS level hysteresis input</li> <li>• With pull-up resistor control</li> <li>• With standby mode control</li> <li>• Pull-up resistor : Approximately 50kΩ</li> <li>• I<sub>OH</sub> = -4mA, I<sub>OL</sub> = 4mA</li> </ul>
F	<p>The circuit diagram for Type F shows a CMOS output stage similar to Type E, but with an additional analog input. It consists of a P-channel MOSFET (P-ch) and an N-channel MOSFET (N-ch) connected in a push-pull configuration. The gates of both MOSFETs are connected to a common input node. This node is pulled up to V<sub>DD</sub> by a resistor R. The input node is also connected to a digital input signal through an inverter. A standby mode control signal is connected to the gates of both MOSFETs. The output of the P-ch MOSFET is labeled 'Digital output'. An analog input signal is connected to the gates of both MOSFETs through an inverter. An input control signal is connected to the gates of both MOSFETs.</p>	<ul style="list-style-type: none"> <li>• CMOS level output</li> <li>• CMOS level hysteresis input</li> <li>• With input control</li> <li>• Analog input</li> <li>• With pull-up resistor control</li> <li>• With standby mode control</li> <li>• Pull-up resistor : Approximately 50kΩ</li> <li>• I<sub>OH</sub> = -4mA, I<sub>OL</sub> = 4mA</li> </ul>

# MB9A130N Series

Type	Circuit	Remarks
G		<ul style="list-style-type: none"> <li>• CMOS level output</li> <li>• CMOS level hysteresis input</li> <li>• With standby mode control</li> <li>• 5 V tolerant input</li> <li>• <math>I_{OH} = -4\text{mA}</math>, <math>I_{OL} = 4\text{mA}</math></li> <li>• Available to control PZR registers. P0B, P0C, P4C, P60, P81, P82 only.</li> </ul>
H		CMOS level hysteresis input
J		<ul style="list-style-type: none"> <li>• CMOS level output</li> <li>• CMOS level hysteresis input</li> <li>• With input control</li> <li>• Analog output</li> <li>• With pull-up resistor control</li> <li>• With standby mode control</li> <li>• Pull-up resistor : Approximately <math>50\text{k}\Omega</math></li> <li>• <math>I_{OH} = -4\text{mA}</math>, <math>I_{OL} = 4\text{mA}</math></li> </ul>

## ■ HANDLING PRECAUTIONS

Any semiconductor devices have inherently a certain rate of failure. The possibility of failure is greatly affected by the conditions in which they are used (circuit conditions, environmental conditions, etc.). This page describes precautions that must be observed to minimize the chance of failure and to obtain higher reliability from your FUJITSU SEMICONDUCTOR semiconductor devices.

### 1. Precautions for Product Design

This section describes precautions when designing electronic equipment using semiconductor devices.

#### • Absolute Maximum Ratings

Semiconductor devices can be permanently damaged by application of stress (voltage, current, temperature, etc.) in excess of certain established limits, called absolute maximum ratings. Do not exceed these ratings.

#### • Recommended Operating Conditions

Recommended operating conditions are normal operating ranges for the semiconductor device. All the device's electrical characteristics are warranted when operated within these ranges.

Always use semiconductor devices within the recommended operating conditions. Operation outside these ranges may adversely affect reliability and could result in device failure.

No warranty is made with respect to uses, operating conditions, or combinations not represented on the data sheet. Users considering application outside the listed conditions are advised to contact their sales representative beforehand.

#### • Processing and Protection of Pins

These precautions must be followed when handling the pins which connect semiconductor devices to power supply and input/output functions.

##### (1) Preventing Over-Voltage and Over-Current Conditions

Exposure to voltage or current levels in excess of maximum ratings at any pin is likely to cause deterioration within the device, and in extreme cases leads to permanent damage of the device. Try to prevent such overvoltage or over-current conditions at the design stage.

##### (2) Protection of Output Pins

Shorting of output pins to supply pins or other output pins, or connection to large capacitance can cause large current flows. Such conditions if present for extended periods of time can damage the device.

Therefore, avoid this type of connection.

##### (3) Handling of Unused Input Pins

Unconnected input pins with very high impedance levels can adversely affect stability of operation. Such pins should be connected through an appropriate resistance to a power supply pin or ground pin.

#### • Latch-up

Semiconductor devices are constructed by the formation of P-type and N-type areas on a substrate. When subjected to abnormally high voltages, internal parasitic PNP junctions (called thyristor structures) may be formed, causing large current levels in excess of several hundred mA to flow continuously at the power supply pin. This condition is called latch-up.

**CAUTION:** The occurrence of latch-up not only causes loss of reliability in the semiconductor device, but can cause injury or damage from high heat, smoke or flame. To prevent this from happening, do the following:

- (1) Be sure that voltages applied to pins do not exceed the absolute maximum ratings. This should include attention to abnormal noise, surge levels, etc.
- (2) Be sure that abnormal current flows do not occur during the power-on sequence.

# MB9A130N Series

- **Observance of Safety Regulations and Standards**  
Most countries in the world have established standards and regulations regarding safety, protection from electromagnetic interference, etc. Customers are requested to observe applicable regulations and standards in the design of products.
- **Fail-Safe Design**  
Any semiconductor devices have inherently a certain rate of failure. You must protect against injury, damage or loss from such failures by incorporating safety design measures into your facility and equipment such as redundancy, fire protection, and prevention of over-current levels and other abnormal operating conditions.
- **Precautions Related to Usage of Devices**  
FUJITSU SEMICONDUCTOR semiconductor devices are intended for use in standard applications (computers, office automation and other office equipment, industrial, communications, and measurement equipment, personal or household devices, etc.).

CAUTION: Customers considering the use of our products in special applications where failure or abnormal operation may directly affect human lives or cause physical injury or property damage, or where extremely high levels of reliability are demanded (such as aerospace systems, atomic energy controls, sea floor repeaters, vehicle operating controls, medical devices for life support, etc.) are requested to consult with sales representatives before such use. The company will not be responsible for damages arising from such use without prior approval.

## 2. Precautions for Package Mounting

Package mounting may be either lead insertion type or surface mount type. In either case, for heat resistance during soldering, you should only mount under FUJITSU SEMICONDUCTOR's recommended conditions. For detailed information about mount conditions, contact your sales representative.

- **Lead Insertion Type**  
Mounting of lead insertion type packages onto printed circuit boards may be done by two methods: direct soldering on the board, or mounting by using a socket.  
  
Direct mounting onto boards normally involves processes for inserting leads into through-holes on the board and using the flow soldering (wave soldering) method of applying liquid solder. In this case, the soldering process usually causes leads to be subjected to thermal stress in excess of the absolute ratings for storage temperature. Mounting processes should conform to FUJITSU SEMICONDUCTOR recommended mounting conditions.  
  
If socket mounting is used, differences in surface treatment of the socket contacts and IC lead surfaces can lead to contact deterioration after long periods. For this reason it is recommended that the surface treatment of socket contacts and IC leads be verified before mounting.
- **Surface Mount Type**  
Surface mount packaging has longer and thinner leads than lead-insertion packaging, and therefore leads are more easily deformed or bent. The use of packages with higher pin counts and narrower pin pitch results in increased susceptibility to open connections caused by deformed pins, or shorting due to solder bridges.  
  
You must use appropriate mounting techniques. FUJITSU SEMICONDUCTOR recommends the solder reflow method, and has established a ranking of mounting conditions for each product. Users are advised to mount packages in accordance with FUJITSU SEMICONDUCTOR ranking of recommended conditions.

- **Lead-Free Packaging**

CAUTION: When ball grid array (BGA) packages with Sn-Ag-Cu balls are mounted using Sn-Pb eutectic soldering, junction strength may be reduced under some conditions of use.

- **Storage of Semiconductor Devices**

Because plastic chip packages are formed from plastic resins, exposure to natural environmental conditions will cause absorption of moisture. During mounting, the application of heat to a package that has absorbed moisture can cause surfaces to peel, reducing moisture resistance and causing packages to crack. To prevent, do the following:

- (1) Avoid exposure to rapid temperature changes, which cause moisture to condense inside the product. Store products in locations where temperature changes are slight.
- (2) Use dry boxes for product storage. Products should be stored below 70% relative humidity, and at temperatures between 5°C and 30°C.  
When you open Dry Package that recommends humidity 40% to 70% relative humidity.
- (3) When necessary, FUJITSU SEMICONDUCTOR packages semiconductor devices in highly moisture-resistant aluminum laminate bags, with a silica gel desiccant. Devices should be sealed in their aluminum laminate bags for storage.
- (4) Avoid storing packages where they are exposed to corrosive gases or high levels of dust.

- **Baking**

Packages that have absorbed moisture may be de-moisturized by baking (heat drying). Follow the FUJITSU SEMICONDUCTOR recommended conditions for baking.

Condition: 125°C/24 h

- **Static Electricity**

Because semiconductor devices are particularly susceptible to damage by static electricity, you must take the following precautions:

- (1) Maintain relative humidity in the working environment between 40% and 70%. Use of an apparatus for ion generation may be needed to remove electricity.
- (2) Electrically ground all conveyors, solder vessels, soldering irons and peripheral equipment.
- (3) Eliminate static body electricity by the use of rings or bracelets connected to ground through high resistance (on the level of 1 MΩ).  
Wearing of conductive clothing and shoes, use of conductive floor mats and other measures to minimize shock loads is recommended.
- (4) Ground all fixtures and instruments, or protect with anti-static measures.
- (5) Avoid the use of styrofoam or other highly static-prone materials for storage of completed board assemblies.

### 3. Precautions for Use Environment

Reliability of semiconductor devices depends on ambient temperature and other conditions as described above.

For reliable performance, do the following:

(1) Humidity

Prolonged use in high humidity can lead to leakage in devices as well as printed circuit boards. If high humidity levels are anticipated, consider anti-humidity processing.

(2) Discharge of Static Electricity

When high-voltage charges exist close to semiconductor devices, discharges can cause abnormal operation. In such cases, use anti-static measures or processing to prevent discharges.

(3) Corrosive Gases, Dust, or Oil

Exposure to corrosive gases or contact with dust or oil may lead to chemical reactions that will adversely affect the device. If you use devices in such conditions, consider ways to prevent such exposure or to protect the devices.

(4) Radiation, Including Cosmic Radiation

Most devices are not designed for environments involving exposure to radiation or cosmic radiation. Users should provide shielding as appropriate.

(5) Smoke, Flame

**CAUTION:** Plastic molded devices are flammable, and therefore should not be used near combustible substances. If devices begin to smoke or burn, there is danger of the release of toxic gases.

Customers considering the use of FUJITSU SEMICONDUCTOR products in other special environmental conditions should consult with sales representatives.

Please check the latest handling precautions at the following URL.

<http://edevice.fujitsu.com/fj/handling-e.pdf>

## ■ HANDLING DEVICES

### • Power supply pins

In products with multiple VCC and VSS pins, respective pins at the same potential are interconnected within the device in order to prevent malfunctions such as latch-up. However, all of these pins should be connected externally to the power supply or ground lines in order to reduce electromagnetic emission levels, to prevent abnormal operation of strobe signals caused by the rise in the ground level, and to conform to the total output current rating.

Moreover, connect the current supply source with each Power supply pin and GND pin of this device at low impedance. It is also advisable that a ceramic capacitor of approximately 0.1  $\mu\text{F}$  be connected as a bypass capacitor between each Power supply pin and GND pin near this device.

### • Crystal oscillator circuit

Noise near the X0/X1 and X0A/X1A pins may cause the device to malfunction. Design the printed circuit board so that X0/X1, X0A/X1A pins, the crystal oscillator, and the bypass capacitor to ground are located as close to the device as possible.

It is strongly recommended that the PC board artwork be designed such that the X0/X1 and X0A/X1A pins are surrounded by ground plane as this is expected to produce stable operation.

### • Using an external clock

To use the external clock, set general-purpose I/O ports to input the clock to X0/PE2 and X0A/P46 pin.

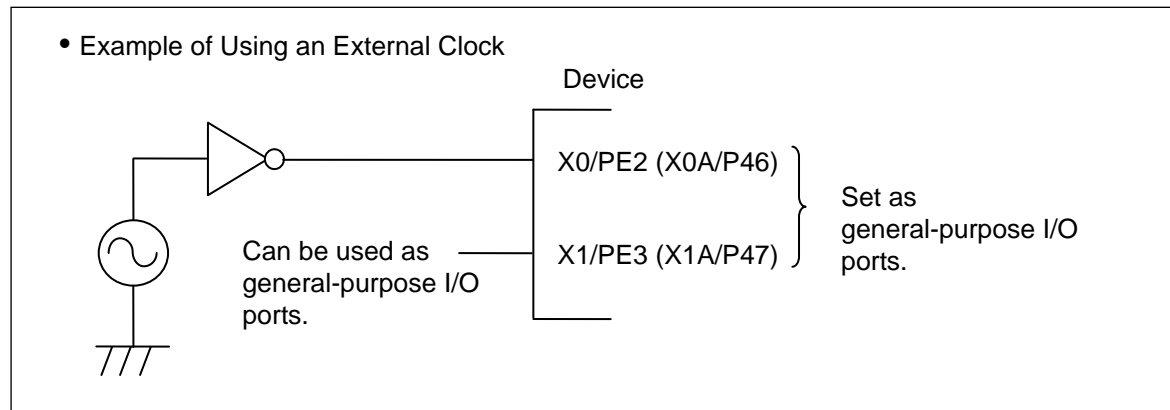

### • Handling when using Multi-function serial pin as I<sup>2</sup>C pin

If it is using the multi-function serial pin as I<sup>2</sup>C pins, P-ch transistor of digital output is always disabled. However, I<sup>2</sup>C pins need to keep the electrical characteristic like other pins and not to connect to the external I<sup>2</sup>C bus system with power OFF.

# MB9A130N Series

- C Pin

This series contains the regulator. Be sure to connect a smoothing capacitor ( $C_S$ ) for the regulator between the C pin and the GND pin. Please use a ceramic capacitor or a capacitor of equivalent frequency characteristics as a smoothing capacitor.

However, some laminated ceramic capacitors have the characteristics of capacitance variation due to thermal fluctuation (F characteristics and Y5V characteristics). Please select the capacitor that meets the specifications in the operating conditions to use by evaluating the temperature characteristics of a capacitor.

A smoothing capacitor of about  $4.7\mu\text{F}$  would be recommended for this series.

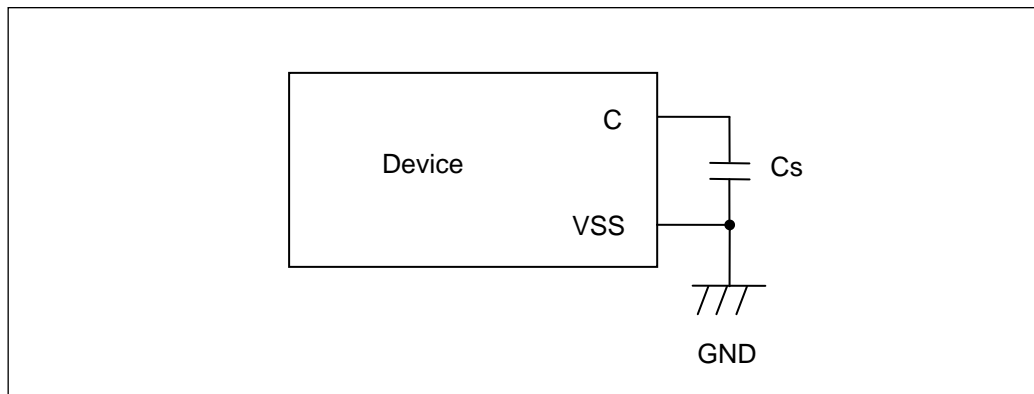

- Mode pins (MD0, MD1)

Connect the MD pin (MD0, MD1) directly to VCC or VSS pins. Design the printed circuit board such that the pull-up/down resistance stays low, as well as the distance between the mode pins and VCC pins or VSS pins is as short as possible and the connection impedance is low, when the pins are pulled-up/down such as for switching the pin level and rewriting the Flash memory data. It is because of preventing the device erroneously switching to test mode due to noise.

- Notes on power-on

Turn power on/off in the following order or at the same time.

If not using the A/D converter, connect  $AVCC = VCC$  and  $AVSS = VSS$ .

Turning on :  $VCC \rightarrow AVCC \rightarrow AVRH$

Turning off :  $AVRH \rightarrow AVCC \rightarrow VCC$

- Serial Communication

There is a possibility to receive wrong data due to the noise or other causes on the serial communication. Therefore, design a printed circuit board so as to avoid noise.

Consider the case of receiving wrong data due to noise, perform error detection such as by applying a checksum of data at the end. If an error is detected, retransmit the data.

- Differences in features among the products with different memory sizes and between Flash memory products and MASK products

The electric characteristics including power consumption, ESD, latch-up, noise characteristics, and oscillation characteristics among the products with different memory sizes and between Flash memory products and MASK products are different because chip layout and memory structures are different.

If you are switching to use a different product of the same series, please make sure to evaluate the electric characteristics.

## ■ BLOCK DIAGRAM

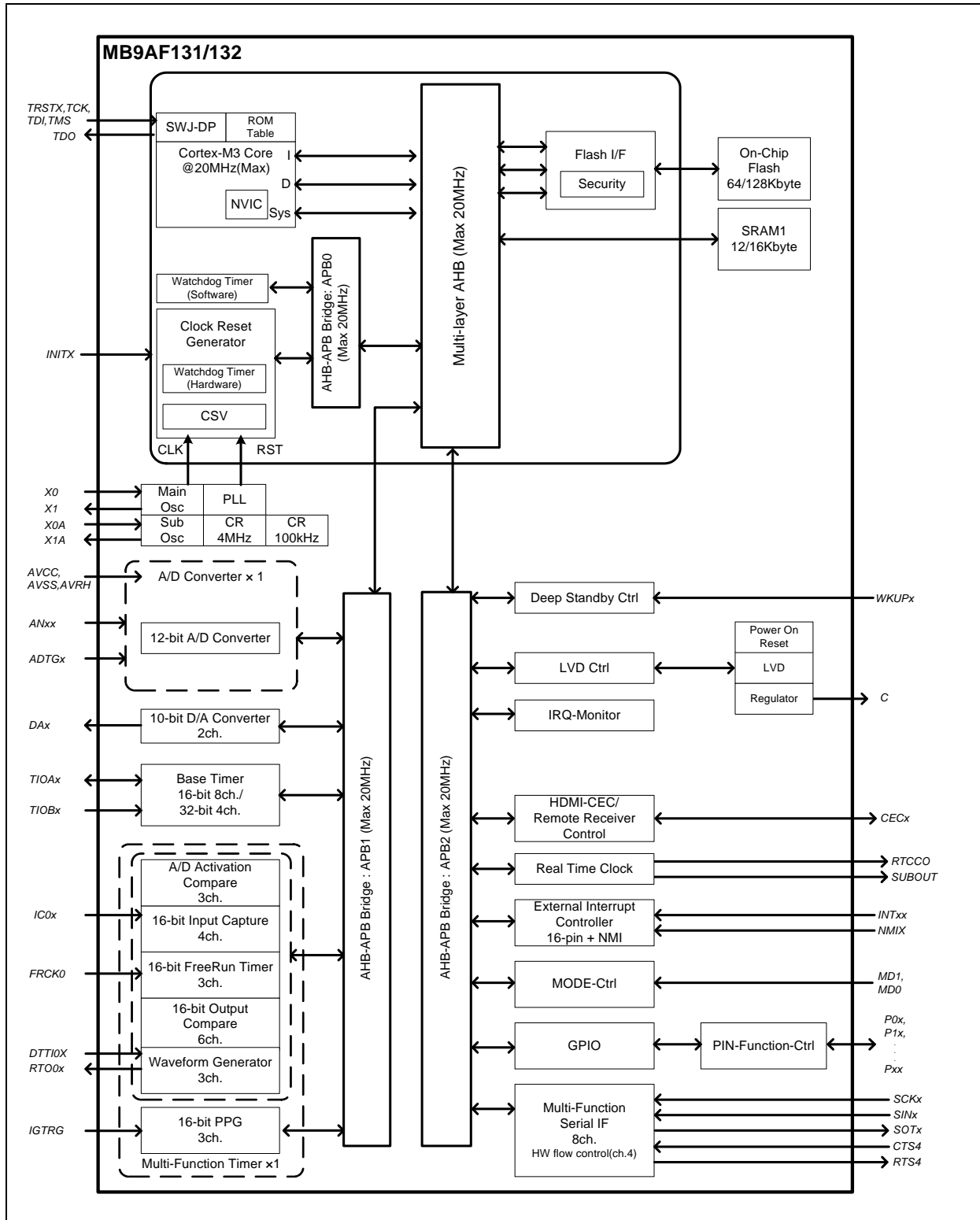

## ■ MEMORY SIZE

See " • Memory size" in "■PRODUCT LINEUP" to confirm the memory size.

# MB9A130N Series

## MEMORY MAP

- Memory Map (1)

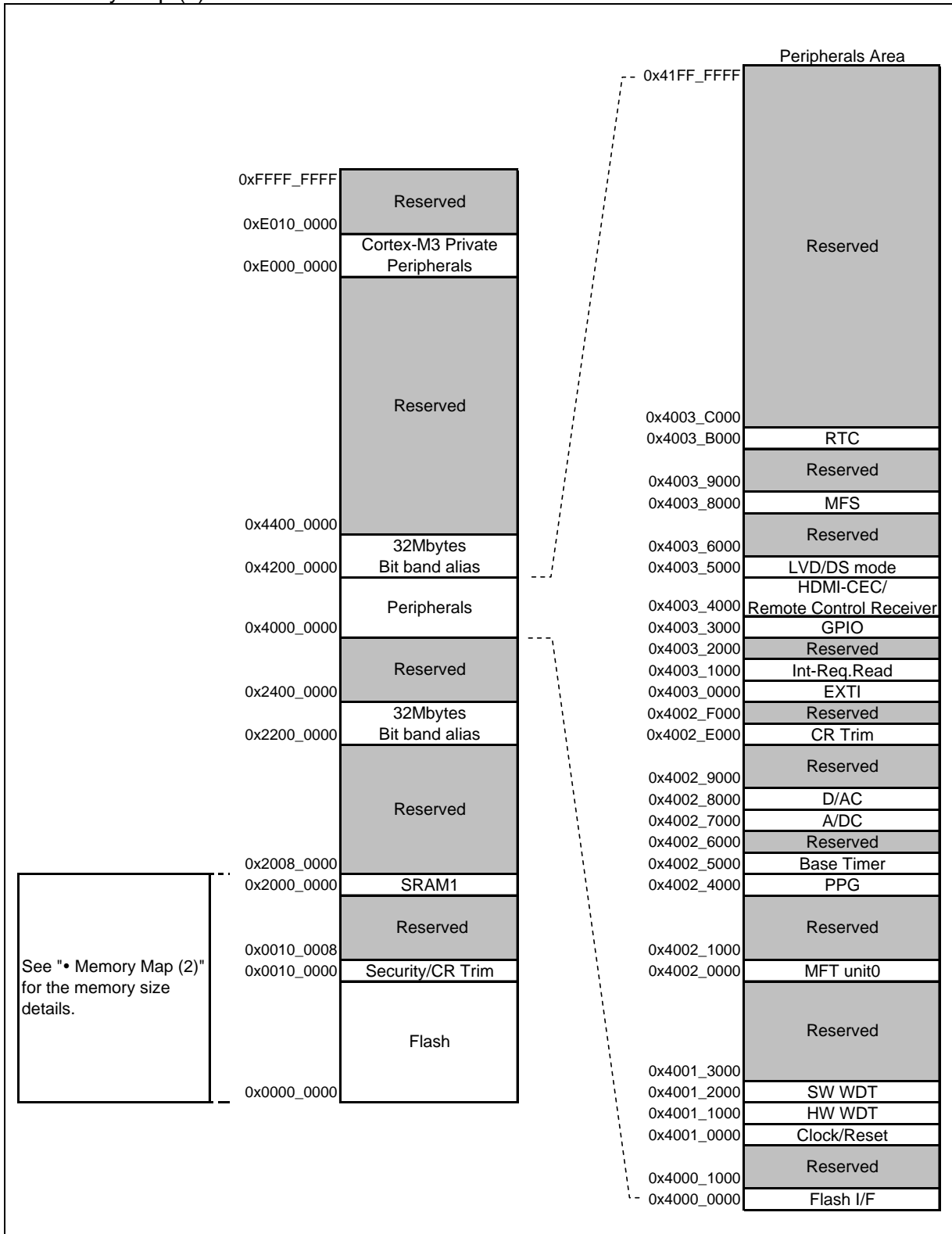

See "• Memory Map (2)" for the memory size details.

# MB9A130N Series

- Memory Map (2)

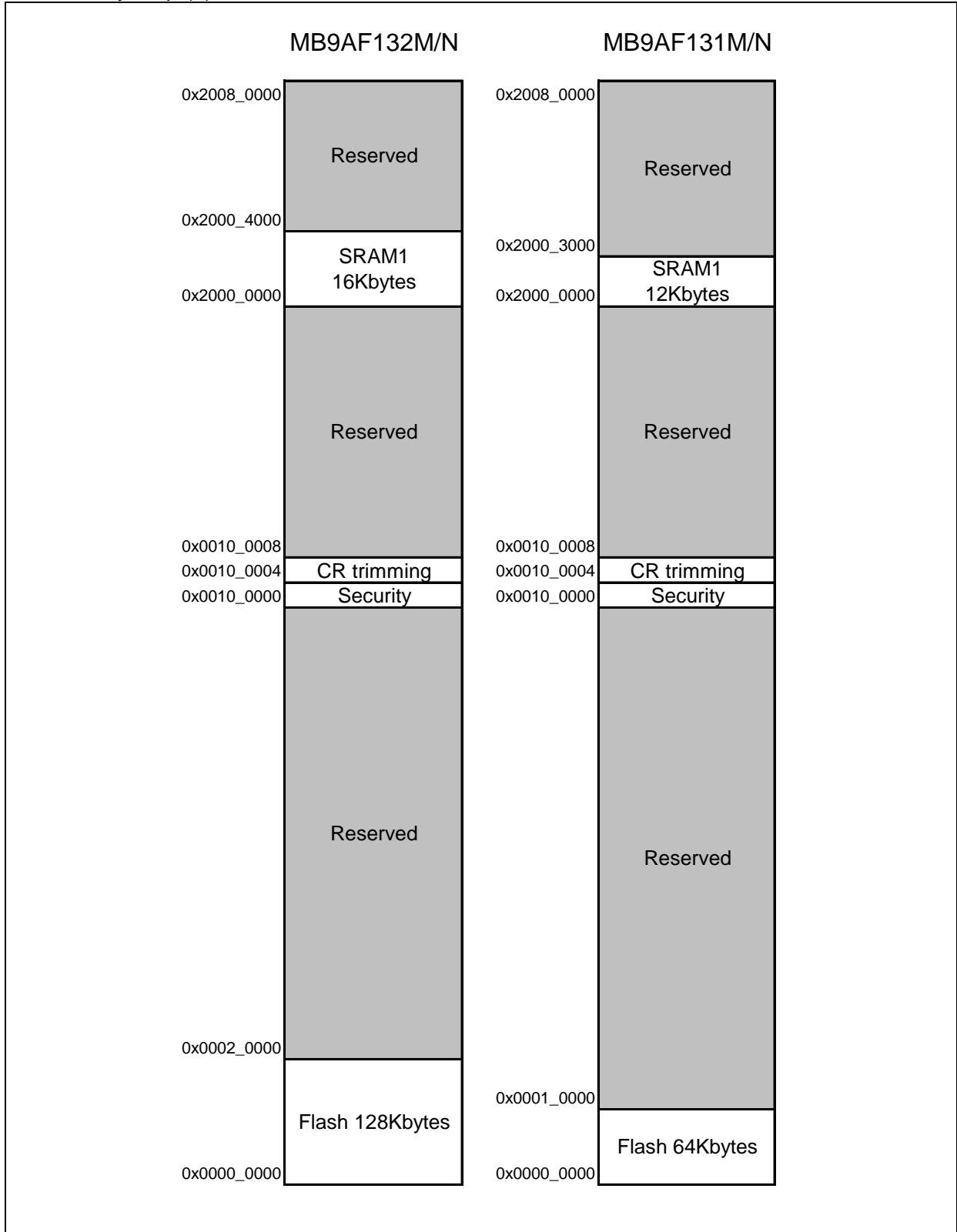

# MB9A130N Series

## • Peripheral Address Map

Start address	End address	Bus	Peripherals	
0x4000_0000	0x4000_0FFF	AHB	Flash memory I/F register	
0x4000_1000	0x4000_FFFF		Reserved	
0x4001_0000	0x4001_0FFF	APB0	Clock/Reset Control	
0x4001_1000	0x4001_1FFF		Hardware Watchdog timer	
0x4001_2000	0x4001_2FFF		Software Watchdog timer	
0x4001_3000	0x4001_4FFF		Reserved	
0x4001_5000	0x4001_5FFF		Reserved	
0x4001_6000	0x4001_FFFF		Reserved	
0x4002_0000	0x4002_0FFF		APB1	Multi-function timer unit0
0x4002_1000	0x4002_1FFF	Reserved		
0x4002_2000	0x4002_3FFF	Reserved		
0x4002_4000	0x4002_4FFF	PPG		
0x4002_5000	0x4002_5FFF	Base Timer		
0x4002_6000	0x4002_6FFF	Reserved		
0x4002_7000	0x4002_7FFF	A/D Converter		
0x4002_8000	0x4002_8FFF	D/A Converter		
0x4002_9000	0x4002_DFFF	Reserved		
0x4002_E000	0x4002_EFFF	Built-in CR trimming		
0x4002_F000	0x4002_FFFF	Reserved		
0x4003_0000	0x4003_0FFF	APB2		External Interrupt
0x4003_1000	0x4003_1FFF			Interrupt Source Check Register
0x4003_2000	0x4003_2FFF		Reserved	
0x4003_3000	0x4003_3FFF		GPIO	
0x4003_4000	0x4003_4FFF		HDMI-CEC/ Remote Control Receiver	
0x4003_5000	0x4003_50FF		Low-Voltage Detector	
0x4003_5100	0x4003_5FFF		Deep standby mode Controller	
0x4003_6000	0x4003_6FFF		Reserved	
0x4003_7000	0x4003_7FFF		Reserved	
0x4003_8000	0x4003_8FFF		Multi-function serial	
0x4003_9000	0x4003_9FFF		Reserved	
0x4003_A000	0x4003_AFFF		Reserved	
0x4003_B000	0x4003_BFFF		Real-time clock	
0x4003_C000	0x4003_FFFF		Reserved	
0x4004_0000	0x4004_FFFF		AHB	Reserved
0x4005_0000	0x4005_FFFF	Reserved		
0x4006_0000	0x4006_0FFF	Reserved		
0x4006_1000	0x4006_1FFF	Reserved		
0x4006_2000	0x4006_2FFF	Reserved		
0x4006_3000	0x4006_3FFF	Reserved		
0x4006_4000	0x41FF_FFFF	Reserved		

## ■ PIN STATUS IN EACH CPU STATE

The terms used for pin status have the following meanings.

- INITX = 0  
This is the period when the INITX pin is the "L" level.
- INITX = 1  
This is the period when the INITX pin is the "H" level.
- SPL = 0  
This is the status that the standby pin level setting bit (SPL) in the standby mode control register (STB\_CTL) is set to "0".
- SPL = 1  
This is the status that the standby pin level setting bit (SPL) in the standby mode control register (STB\_CTL) is set to "1".
- Input enabled  
Indicates that the input function can be used.
- Internal input fixed at "0"  
This is the status that the input function cannot be used. Internal input is fixed at "L".
- Hi-Z  
Indicates that the pin drive transistor is disabled and the pin is put in the Hi-Z state.
- Setting disabled  
Indicates that the setting is disabled.
- Maintain previous state  
Maintains the state that was immediately prior to entering the current mode.  
If a built-in peripheral function is operating, the output follows the peripheral function.  
If the pin is being used as a port, that output is maintained.
- Analog input is enabled  
Indicates that the analog input is enabled.
- Trace output  
Indicates that the trace function can be used.
- GPIO selected  
In Deep standby mode, pins switch to the general-purpose I/O port.

# MB9A130N Series

## • List of Pin Status

Pin status type	Function group	Power-on reset or low-voltage detection state	INITX input state	Device internal reset state	Run mode or SLEEP mode state	Timer mode, RTC mode, or STOP mode state		Deep standby RTC mode or Deep standby STOP mode state		Return from Deep standby mode state
		Power supply unstable	Power supply stable		Power supply stable	Power supply stable		Power supply stable		Power supply stable
		-	INITX = 0	INITX = 1	INITX = 1	INITX = 1		INITX = 1		INITX = 1
		-	-	-	-	SPL = 0	SPL = 1	SPL = 0	SPL = 1	-
A	Main crystal oscillator input pin	Input enabled	Input enabled	Input enabled	Input enabled	Input enabled	Input enabled	Input enabled	Input enabled	Input enabled
	External main clock input selected	Setting disabled	Setting disabled	Setting disabled	Maintain previous state	Maintain previous state / When oscillation stops* <sup>1</sup> , output maintains previous state / Internal input fixed at "0"	Hi-Z / Input enabled / When oscillation stops* <sup>1</sup> , Hi-Z / Internal input fixed at "0"	Output maintains previous state / Internal input fixed at "0"	Hi-Z / Internal input fixed at "0"	GPIO selected
	GPIO selected	Setting disabled	Setting disabled	Setting disabled	Maintain previous state	Output maintains previous state / Internal input fixed at "0"	Hi-Z / Internal input fixed at "0"	Output maintains previous state / Internal input fixed at "0"	Hi-Z / Internal input fixed at "0"	Maintain previous state
B	Main crystal oscillator output pin	Hi-Z / Internal input fixed at "0"	Hi-Z / Internal input fixed at "0"	Hi-Z / Internal input fixed at "0"	Maintain previous state / When oscillation stops* <sup>1</sup> , Hi-Z output / Internal input fixed at "0"	Maintain previous state / When oscillation stops* <sup>1</sup> , Hi-Z output / Internal input fixed at "0"	Maintain previous state / When oscillation stops* <sup>1</sup> , Hi-Z output / Internal input fixed at "0"	Maintain previous state / When oscillation stops* <sup>1</sup> , Hi-Z output / Internal input fixed at "0"	Maintain previous state / When oscillation stops* <sup>1</sup> , Hi-Z output / Internal input fixed at "0"	Maintain previous state / When oscillation stops* <sup>1</sup> , Hi-Z output / Internal input fixed at "0"
	GPIO selected	Setting disabled	Setting disabled	Setting disabled	Maintain previous state	Maintain previous state	Hi-Z / Internal input fixed at "0"	Output maintains previous state / Internal input fixed at "0"	Hi-Z / Internal input fixed at "0"	Maintain previous state
C	INITX input pin	Pull-up / Input enabled	Pull-up / Input enabled	Pull-up / Input enabled	Pull-up / Input enabled	Pull-up / Input enabled	Pull-up / Input enabled	Pull-up / Input enabled	Pull-up / Input enabled	Pull-up / Input enabled

# MB9A130N Series

Pin status type	Function group	Power-on reset or low-voltage detection state	INITX input state	Device internal reset state	Run mode or SLEEP mode state	Timer mode, RTC mode, or STOP mode state		Deep standby RTC mode or Deep standby STOP mode state		Return from Deep standby mode state
		Power supply unstable	Power supply stable		Power supply stable	Power supply stable		Power supply stable		Power supply stable
		-	INITX = 0	INITX = 1	INITX = 1	INITX = 1		INITX = 1		INITX = 1
		-	-	-	-	SPL = 0	SPL = 1	SPL = 0	SPL = 1	-
D	Mode input pin	Input enabled	Input enabled	Input enabled	Input enabled	Input enabled	Input enabled	Input enabled	Input enabled	Input enabled
E	JTAG selected	Hi-Z	Pull-up / Input enabled	Pull-up / Input enabled	Maintain previous state	Maintain previous state	Maintain previous state	Maintain previous state	Maintain previous state	Maintain previous state
	GPIO selected	Setting disabled	Setting disabled	Setting disabled	Maintain previous state	Maintain previous state	Hi-Z / Internal input fixed at "0"	Maintain previous state	Hi-Z / Internal input fixed at "0"	Maintain previous state
F	External interrupt enabled selected	Setting disabled	Setting disabled	Setting disabled	Maintain previous state	Maintain previous state	Maintain previous state	GPIO selected Internal input fixed at "0"	Hi-Z / Internal input fixed at "0"	GPIO selected
	Resource other than above selected	Hi-Z	Hi-Z / Input enabled	Hi-Z / Input enabled			Hi-Z / Internal input fixed at "0"			
	GPIO selected						Output maintains previous state / Internal input fixed at "0"	Maintain previous state		
G	WKUP enabled	Setting disabled	Setting disabled	Setting disabled	Maintain previous state	Maintain previous state	Hi-Z / Internal input fixed at "0"	WKUP input enabled	Hi-Z / WKUP input enabled	GPIO selected
	External interrupt enabled selected	Setting disabled	Setting disabled	Setting disabled			Maintain previous state	GPIO selected Internal input fixed at "0"	Hi-Z / Internal input fixed at "0"	
	Resource other than above selected	Hi-Z	Hi-Z / Input enabled	Hi-Z / Input enabled			Hi-Z / Internal input fixed at "0"			
	GPIO selected						Output maintains previous state / Internal input fixed at "0"	Maintain previous state		

# MB9A130N Series

Pin status type	Function group	Power-on reset or low-voltage detection state	INITX input state	Device internal reset state	Run mode or SLEEP mode state	Timer mode, RTC mode, or STOP mode state		Deep standby RTC mode or Deep standby STOP mode state		Return from Deep standby mode state	
		Power supply unstable	Power supply stable		Power supply stable	Power supply stable		Power supply stable		Power supply stable	
		-	INITX = 0	INITX = 1	INITX = 1	INITX = 1		INITX = 1		INITX = 1	
		-	-	-	-	SPL = 0	SPL = 1	SPL = 0	SPL = 1	-	
H	Resource selected	Hi-Z	Hi-Z / Input enabled	Hi-Z / Input enabled	Maintain previous state	Maintain previous state	Hi-Z / Internal input fixed at "0"	GPIO selected Internal input fixed at "0"	Hi-Z / Internal input fixed at "0"	GPIO selected	
	GPIO selected		Output maintains previous state / Internal input fixed at "0"	Maintain previous state							
I	NMIX selected	Setting disabled	Setting disabled	Setting disabled	Maintain previous state	Maintain previous state	Maintain previous state	WKUP input enabled	Hi-Z / WKUP input enabled	GPIO selected	
	Resource other than above selected	Hi-Z	Hi-Z / Input enabled	Hi-Z / Input enabled			Hi-Z / Internal input fixed at "0"				Maintain previous state
	GPIO selected	Maintain previous state									
J	Analog input selected	Hi-Z	Hi-Z / Internal input fixed at "0" / Analog input enabled	Hi-Z / Internal input fixed at "0" / Analog input enabled	Hi-Z / Internal input fixed at "0" / Analog input enabled	Hi-Z / Internal input fixed at "0" / Analog input enabled	Hi-Z / Internal input fixed at "0" / Analog input enabled	Hi-Z / Internal input fixed at "0" / Analog input enabled	Hi-Z / Internal input fixed at "0" / Analog input enabled	Hi-Z / Internal input fixed at "0" / Analog input enabled	
	Resource other than above selected	Setting disabled	Setting disabled	Setting disabled	Maintain previous state	Maintain previous state	Hi-Z / Internal input fixed at "0"	GPIO selected Internal input fixed at "0"	Hi-Z / Internal input fixed at "0"	GPIO selected	
GPIO selected	Output maintains previous state / Internal input fixed at "0"						Maintain previous state				

# MB9A130N Series

Pin status type	Function group	Power-on reset or low-voltage detection state	INITX input state	Device internal reset state	Run mode or SLEEP mode state	Timer mode, RTC mode, or STOP mode state		Deep standby RTC mode or Deep standby STOP mode state		Return from Deep standby mode state
		Power supply unstable	Power supply stable		Power supply stable	Power supply stable		Power supply stable		Power supply stable
		-	INITX = 0	INITX = 1	INITX = 1	INITX = 1		INITX = 1		INITX = 1
		-	-	-	-	SPL = 0	SPL = 1	SPL = 0	SPL = 1	-
K	Analog input selected	Hi-Z	Hi-Z / Internal input fixed at "0" / Analog input enabled	Hi-Z / Internal input fixed at "0" / Analog input enabled	Hi-Z / Internal input fixed at "0" / Analog input enabled	Hi-Z / Internal input fixed at "0" / Analog input enabled	Hi-Z / Internal input fixed at "0" / Analog input enabled	Hi-Z / Internal input fixed at "0" / Analog input enabled	Hi-Z / Internal input fixed at "0" / Analog input enabled	Hi-Z / Internal input fixed at "0" / Analog input enabled
	External interrupt enabled selected	Setting disabled	Setting disabled	Setting disabled	Maintain previous state	Maintain previous state	Maintain previous state	GPIO selected Internal input fixed at "0"	Hi-Z / Internal input fixed at "0"	GPIO selected
	Resource other than above selected						Hi-Z / Internal input fixed at "0"			
GPIO selected										Maintain previous state
L	Analog input selected	Hi-Z	Hi-Z / Internal input fixed at "0" / Analog input enabled	Hi-Z / Internal input fixed at "0" / Analog input enabled	Hi-Z / Internal input fixed at "0" / Analog input enabled	Hi-Z / Internal input fixed at "0" / Analog input enabled	Hi-Z / Internal input fixed at "0" / Analog input enabled	Hi-Z / Internal input fixed at "0" / Analog input enabled	Hi-Z / Internal input fixed at "0" / Analog input enabled	Hi-Z / Internal input fixed at "0" / Analog input enabled
	WKUP enabled	Setting disabled	Setting disabled	Setting disabled	Maintain previous state	Maintain previous state	Hi-Z / Internal input fixed at "0"	WKUP input enabled	Hi-Z / WKUP input enabled	Hi-Z / Internal input fixed at "0"
	External interrupt enabled selected						Maintain previous state	GPIO selected Internal input fixed at "0"	GPIO selected	
	Resource other than above selected						Hi-Z / Internal input fixed at "0"	Output maintains previous state / Internal input fixed at "0"	Maintain previous state	
GPIO selected										Maintain previous state

# MB9A130N Series

Pin status type	Function group	Power-on reset or low-voltage detection state	INITX input state	Device internal reset state	Run mode or SLEEP mode state	Timer mode, RTC mode, or STOP mode state		Deep standby RTC mode or Deep standby STOP mode state		Return from Deep standby mode state
		Power supply unstable	Power supply stable		Power supply stable	Power supply stable		Power supply stable		Power supply stable
		-	INITX = 0	INITX = 1	INITX = 1	INITX = 1		INITX = 1		INITX = 1
		-	-	-	-	SPL = 0	SPL = 1	SPL = 0	SPL = 1	-
M	Sub crystal oscillator input pin	Input enabled	Input enabled	Input enabled	Input enabled	Input enabled	Input enabled	Input enabled	Input enabled	Input enabled
	External sub clock input selected	Setting disabled	Setting disabled	Setting disabled	Maintain previous state	Maintain previous state / When oscillation stops* <sup>2</sup> , output maintains previous state / Internal input fixed at "0"	Hi-Z / Input enabled / When oscillation stops* <sup>2</sup> , Hi-Z / Internal input fixed at "0"	Maintain previous state / When oscillation stops* <sup>2</sup> , output maintains previous state / Internal input fixed at "0"	Hi-Z / Input enabled / When oscillation stops* <sup>2</sup> , Hi-Z / Internal input fixed at "0"	Maintain previous state / When Return from Deep Standby STOP mode, GPIO is selected
	GPIO selected	Setting disabled	Setting disabled	Setting disabled	Maintain previous state	Output maintains previous state / Internal input fixed at "0"	Hi-Z / Internal input fixed at "0"	Output maintains previous state / Internal input fixed at "0"	Hi-Z / Internal input fixed at "0"	Maintain previous state
N	Sub crystal oscillator output pin	Hi-Z / Internal input fixed at "0"	Hi-Z / Internal input fixed at "0"	Hi-Z / Internal input fixed at "0"	Maintain previous state	Maintain previous state / When oscillation stops* <sup>2</sup> , Hi-Z / Internal input fixed at "0"	Maintain previous state / When oscillation stops* <sup>2</sup> , Hi-Z / Internal input fixed at "0"	Maintain previous state / When oscillation stops* <sup>2</sup> , Hi-Z / Internal input fixed at "0"	Maintain previous state / When oscillation stops* <sup>2</sup> , Hi-Z / Internal input fixed at "0"	Maintain previous state / When oscillation stops* <sup>2</sup> , Hi-Z / Internal input fixed at "0"
	GPIO selected	Setting disabled	Setting disabled	Setting disabled	Maintain previous state	Maintain previous state	Hi-Z / Internal input fixed at "0"	Output maintains previous state / Internal input fixed at "0"	Hi-Z / Internal input fixed at "0"	Maintain previous state

# MB9A130N Series

Pin status type	Function group	Power-on reset or low-voltage detection state	INITX input state	Device internal reset state	Run mode or SLEEP mode state	Timer mode, RTC mode, or STOP mode state		Deep standby RTC mode or Deep standby STOP mode state		Return from Deep standby mode state
		Power supply unstable	Power supply stable		Power supply stable	Power supply stable		Power supply stable		Power supply stable
		-	INITX = 0	INITX = 1	INITX = 1	INITX = 1		INITX = 1		INITX = 1
		-	-	-	-	SPL = 0	SPL = 1	SPL = 0	SPL = 1	-
O	External interrupt enabled selected	Setting disabled	Setting disabled	Setting disabled	Maintain previous state	Maintain previous state	Maintain previous state	GPIO selected / Internal input fixed at "0"	Hi-Z / Internal input fixed at "0"	GPIO selected
	GPIO selected	Hi-Z	Hi-Z / Input enabled	Hi-Z / Input enabled			Hi-Z / Internal input fixed at "0"	Output maintains previous state / Internal input fixed at "0"		Maintain previous state
P	Mode input pin	Input enabled	Input enabled	Input enabled	Input enabled	Input enabled	Input enabled	Input enabled	Input enabled	Input enabled
	GPIO selected	Setting disabled	Setting disabled	Setting disabled	Maintain previous state	Maintain previous state	Hi-Z / input enabled	Maintain previous state	Hi-Z / input enabled	Maintain previous state
Q	CEC enabled	Setting disabled	Setting disabled	Setting disabled	Maintain previous state	Maintain previous state	Maintain previous state	Maintain previous state	Maintain previous state	Maintain previous state
	Resource other than above selected	Hi-Z	Hi-Z / Input enabled	Hi-Z / Input enabled	Maintain previous state	Maintain previous state	Hi-Z / Internal input fixed at "0"	GPIO selected / Internal input fixed at "0"	Hi-Z / Internal input fixed at "0"	GPIO selected
	GPIO selected						Output maintains previous state / Internal input fixed at "0"	Maintain previous state		

# MB9A130N Series

Pin status type	Function group	Power-on reset or low-voltage detection state	INITX input state	Device internal reset state	Run mode or SLEEP mode state	Timer mode, RTC mode, or STOP mode state		Deep standby RTC mode or Deep standby STOP mode state		Return from Deep standby mode state				
		Power supply unstable	Power supply stable		Power supply stable	Power supply stable		Power supply stable		Power supply stable				
		-	INITX = 0	INITX = 1	INITX = 1	INITX = 1		INITX = 1		INITX = 1				
		-	-	-	-	SPL = 0	SPL = 1	SPL = 0	SPL = 1	-				
R	CEC enabled	Setting disabled	Setting disabled	Setting disabled	Maintain previous state	Maintain previous state	Maintain previous state	Maintain previous state	Maintain previous state	Maintain previous state				
	WKUP enabled	Setting disabled	Setting disabled	Setting disabled	Maintain previous state	Maintain previous state	Hi-Z / Internal input fixed at "0"	WKUP input enabled	Hi-Z / WKUP input enabled	GPIO selected				
	External interrupt enabled selected						Maintain previous state	GPIO selected	Internal input fixed at "0"					
	Resource other than above selected	Hi-Z	Hi-Z / Input enabled	Hi-Z / Input enabled			Maintain previous state	Hi-Z / Internal input fixed at "0"	Output maintains previous state / Internal input fixed at "0"		Hi-Z / Internal input fixed at "0"	Maintain previous state		
	GPIO selected													
S	Analog output selected	Setting disabled	Setting disabled	Setting disabled	Maintain previous state	Maintain previous state	*3	*4	GPIO selected	Internal input fixed at "0"	Hi-Z / Internal input fixed at "0"	Output maintains previous state / Internal input fixed at "0"	Maintain previous state	
	External interrupt enabled selected	Setting disabled	Setting disabled	Setting disabled										Maintain previous state
	Resource other than above selected	Hi-Z	Hi-Z / Input enabled	Hi-Z / Input enabled			Maintain previous state	Hi-Z / Internal input fixed at "0"						Output maintains previous state / Internal input fixed at "0"
	GPIO selected													

# MB9A130N Series

Pin status type	Function group	Power-on reset or low-voltage detection state	INITX input state	Device internal reset state	Run mode or SLEEP mode state	Timer mode, RTC mode, or STOP mode state		Deep standby RTC mode or Deep standby STOP mode state		Return from Deep standby mode state
		Power supply unstable	Power supply stable		Power supply stable	Power supply stable		Power supply stable		Power supply stable
		-	INITX = 0	INITX = 1	INITX = 1	INITX = 1		INITX = 1		INITX = 1
		-	-	-	-	SPL = 0	SPL = 1	SPL = 0	SPL = 1	-
T	Analog output selected	Setting disabled	Setting disabled	Setting disabled	Maintain previous state	*3	*4	GPIO selected Internal input fixed at "0"	Hi-Z / Internal input fixed at "0"	GPIO selected
	Resource other than above selected	Hi-Z	Hi-Z / Input enabled	Hi-Z / Input enabled		Maintain previous state	Hi-Z / Internal input fixed at "0"			
	GPIO selected							Maintain previous state		

\*1 : Oscillation is stopped at Sub run mode, Low-speed CR run mode, Sub SLEEP mode, Low-speed CR SLEEP mode, Sub timer mode, Low-speed CR timer mode, RTC mode, STOP mode, Deep standby RTC mode, and Deep standby STOP mode.

\*2 : Oscillation is stopped at STOP mode and Deep standby STOP mode.

\*3 : Maintain previous state at timer mode. GPIO selected Internal input fixed at "0" at RTC mode, STOP mode.

\*4 : Maintain previous state at timer mode. Hi-Z/Internal input fixed at "0" at RTC mode, STOP mode.

# MB9A130N Series

## ■ ELECTRICAL CHARACTERISTICS

### 1. Absolute Maximum Ratings

Parameter	Symbol	Rating		Unit	Remarks
		Min	Max		
Power supply voltage*1,*2	$V_{CC}$	$V_{SS} - 0.5$	$V_{SS} + 6.5$	V	
Analog power supply voltage*1,*3	$AV_{CC}$	$V_{SS} - 0.5$	$V_{SS} + 6.5$	V	
Analog reference voltage*1,*3	$AV_{RH}$	$V_{SS} - 0.5$	$V_{SS} + 6.5$	V	
Input voltage*1	$V_I$	$V_{SS} - 0.5$	$V_{CC} + 0.5$ ( $\leq 6.5V$ )	V	
		$V_{SS} - 0.5$	$V_{SS} + 6.5$	V	5V tolerant
Analog pin input voltage*1	$V_{IA}$	$V_{SS} - 0.5$	$AV_{CC} + 0.5$ ( $\leq 6.5V$ )	V	
Output voltage*1	$V_O$	$V_{SS} - 0.5$	$V_{CC} + 0.5$ ( $\leq 6.5V$ )	V	
"L" level maximum output current*4	$I_{OL}$	-	10	mA	
"L" level average output current*5	$I_{OLAV}$	-	4	mA	
"L" level total maximum output current	$\sum I_{OL}$	-	100	mA	
"L" level total average output current*6	$\sum I_{OLAV}$	-	50	mA	
"H" level maximum output current*4	$I_{OH}$	-	- 10	mA	
"H" level average output current*5	$I_{OHAV}$	-	- 4	mA	
"H" level total maximum output current	$\sum I_{OH}$	-	- 100	mA	
"H" level total average output current*6	$\sum I_{OHAV}$	-	- 50	mA	
Power consumption	$P_D$	-	400	mW	
Storage temperature	$T_{STG}$	- 55	+ 150	°C	

\*1 : These parameters are based on the condition that  $V_{SS} = AV_{SS} = 0V$ .

\*2 :  $V_{CC}$  must not drop below  $V_{SS} - 0.5V$ .

\*3 : Be careful not to exceed  $V_{CC} + 0.5 V$ , for example, when the power is turned on.

\*4 : The maximum output current is defined as the value of the peak current flowing through any one of the corresponding pins.

\*5 : The average output current is defined as the average current value flowing through any one of the corresponding pins for a 100 ms period.

\*6 : The total average output current is defined as the average current value flowing through all of corresponding pins for a 100ms.

### <WARNING>

Semiconductor devices may be permanently damaged by application of stress (including, without limitation, voltage, current or temperature) in excess of absolute maximum ratings.

Do not exceed any of these ratings.

## 2. Recommended Operating Conditions

( $V_{SS} = AV_{SS} = 0.0V$ )

Parameter	Symbol	Conditions	Value		Unit	Remarks	
			Min	Max			
Power supply voltage	$V_{CC}$	-	1.8	5.5	V		
Analog power supply voltage	$AV_{CC}$	-	1.8	5.5	V	$AV_{CC} = V_{CC}$	
Analog reference voltage	AVRH	-	2.7	$AV_{CC}$	V	$AV_{CC} \geq 2.7V$	
			$AV_{CC}$			$AV_{CC} < 2.7V$	
Smoothing capacitor	$C_S$	-	1	10	$\mu F$	For Regulator *	
Operating Temperature	FPT-80P-M37, FPT-80P-M40, FPT-100P-M23, FPT-100P-M06, BGA-112P-M04	$T_a$	-	- 40	+ 85	$^{\circ}C$	

\* : See "●C Pin" in "■HANDLING DEVICES" for the smoothing capacitor.

### <WARNING>

The recommended operating conditions are required in order to ensure the normal operation of the semiconductor device. All of the device's electrical characteristics are warranted when the device is operated under these conditions.

Any use of semiconductor devices will be under their recommended operating condition.

Operation under any conditions other than these conditions may adversely affect reliability of device and could result in device failure.

No warranty is made with respect to any use, operating conditions or combinations not represented on this data sheet. If you are considering application under any conditions other than listed herein, please contact sales representatives beforehand.

# MB9A130N Series

## 3. DC Characteristics

### (1) Current Rating

( $V_{CC} = AV_{CC} = 1.8V$  to  $5.5V$ ,  $V_{SS} = AV_{SS} = 0V$ ,  $T_a = -40^{\circ}C$  to  $+85^{\circ}C$ )

Parameter	Symbol	Pin name	Conditions	Value			Unit	Remarks
				Min	Typ*4	Max		
Power supply current	$I_{CC}$	VCC	Normal operation (PLL)	-	19	24	mA	CPU : 20MHz, Peripheral : 20MHz, Flash memory 0Wait, FRWTR.RWT = 00, FSYNDN.SD = 000 *1
				-	9.5	12.5	mA	CPU : 20MHz, Peripheral : clock stopped, NOP operation *1
			Normal operation (built-in high-speed CR)	-	4.5	5.5	mA	CPU / Peripheral : 4MHz*2, Flash memory 0Wait, FRWTR.RWT = 00, FSYNDN.SD = 000 *1
			Normal operation (sub oscillation)	-	0.25	0.55	mA	CPU / Peripheral : 32kHz, Flash memory 0Wait, FRWTR.RWT = 00, FSYNDN.SD = 000 *1
			Normal operation (built-in low-speed CR)	-	0.3	0.95	mA	CPU / Peripheral : 100kHz, Flash memory 0Wait, FRWTR.RWT = 00, FSYNDN.SD = 000 *1
	$I_{CCS}$		SLEEP operation (PLL)	-	8	10.5	mA	Peripheral : 20MHz *1
			SLEEP operation (built-in high-speed CR)	-	2	2.5	mA	Peripheral : 4MHz*2 *1
			SLEEP operation (sub oscillation)	-	0.2	0.45	mA	Peripheral : 32kHz *1
			SLEEP operation (built-in low-speed CR)	-	0.25	0.65	mA	Peripheral : 100kHz *1
	$I_{CCT}$		TIMER mode (sub oscillation)	-	7.5	60	$\mu A$	$T_a = +25^{\circ}C$ , When LVD is off *1, *3
				-	16	150	$\mu A$	$T_a = +85^{\circ}C$ , When LVD is off *1, *3

# MB9A130N Series

Parameter	Symbol	Pin name	Conditions	Value			Unit	Remarks	
				Min	Typ*4	Max			
Power supply current	I <sub>CCR</sub>	VCC	RTC mode	-	1.5	6.5	μA	Ta = + 25°C, When LVD is off *1, *3	
				-	6	89	μA	Ta = + 85°C, When LVD is off *1, *3	
	I <sub>CCRD</sub>		Deep standby RTC mode	-	1.3	4.5	μA	Ta = + 25°C, When LVD is off *1, *3	
				-	3	32	μA	Ta = + 85°C, When LVD is off *1, *3	
	I <sub>CCH</sub>		STOP mode	-	0.6	5	μA	Ta = + 25°C, When LVD is off *1	
				-	4.2	87	μA	Ta = + 85°C, When LVD is off *1	
	I <sub>CCHD</sub>		Deep standby STOP mode	-	0.4	3	μA	Ta = + 25°C, When LVD is off *1	
				-	1.4	30	μA	Ta = + 85°C, When LVD is off *1	
	Low-voltage detection circuit (LVD) power supply current		I <sub>CCLVD</sub>	For occurrence of reset or for occurrence of interrupt in normal mode operation	-	10	20	μA	When not detected
				For occurrence of reset and for occurrence of interrupt in normal mode operation	-	14	30	μA	
For occurrence of interrupt in low power mode operation		-		0.3	2	μA			

\*1: When all ports are fixed.

\*2: When setting it to 4MHz by trimming.

\*3: When using sub crystal oscillator.

\*4: When V<sub>CC</sub>=3.3V

# MB9A130N Series

## (2) Pin Characteristics

( $V_{CC} = AV_{CC} = 1.8V$  to  $5.5V$ ,  $V_{SS} = AV_{SS} = 0V$ ,  $T_a = -40^{\circ}C$  to  $+85^{\circ}C$ )

Parameter	Symbol	Pin name	Conditions	Value			Unit	Remarks
				Min	Typ	Max		
"H" level input voltage (hysteresis input)	$V_{IHS}$	MD0, MD1, PE0, PE2, PE3, P46, P47, P3A, P3B, P3C, P3D, P3E, P3F, INITX	-	$V_{CC} \times 0.8$	-	$V_{CC} + 0.3$	V	
		P0A, P0B, P0C, P4C, P60, P80, P81, P82	-	$V_{CC} \times 0.7$	-	$V_{SS} + 5.5$	V	5V tolerant
		CMOS hysteresis input pins other than the above	-	$V_{CC} \times 0.7$	-	$V_{CC} + 0.3$	V	
"L" level input voltage (hysteresis input)	$V_{ILS}$	MD0, MD1, PE0, PE2, PE3, P46, P47, INITX	-	$V_{SS} - 0.3$	-	$V_{CC} \times 0.2$	V	
		CMOS hysteresis input pins other than the above	-	$V_{SS} - 0.3$	-	$V_{CC} \times 0.3$	V	
"H" level output voltage	$V_{OH}$	$P_{XX}$	$V_{CC} \geq 4.5V$ , $I_{OH} = -4mA$ $V_{CC} < 4.5V$ , $I_{OH} = -1mA$	$V_{CC} - 0.5$	-	$V_{CC}$	V	
"L" level output voltage	$V_{OL}$	$P_{XX}$	$V_{CC} \geq 4.5V$ , $I_{OL} = 4mA$ $V_{CC} < 4.5V$ , $I_{OL} = 2mA$	$V_{SS}$	-	0.4	V	
Input leak current	$I_{IL}$	-	-	-5	-	+5	$\mu A$	
Pull-up resistor value	$R_{PU}$	Pull-up pin	$V_{CC} \geq 4.5V$	25	50	100	k $\Omega$	
			$V_{CC} < 4.5V$	40	100	400		
Input capacitance	$C_{IN}$	Other than VCC, VSS, AVCC, AVSS, AVRH	-	-	5	15	pF	

## 4. AC Characteristics

### (1) Main Clock Input Characteristics

( $V_{CC} = 1.8V$  to  $5.5V$ ,  $V_{SS} = 0V$ ,  $T_a = -40^{\circ}C$  to  $+85^{\circ}C$ )

Parameter	Symbol	Pin name	Conditions	Value		Unit	Remarks	
				Min	Max			
Input frequency	$F_{CH}$	X0, X1	$V_{CC} \geq 2.0V$	4	20	MHz	When crystal oscillator is connected	
			$V_{CC} < 2.0V$	4	4	MHz		
			$V_{CC} \geq 4.5V$	4	20	MHz	When using external clock	
			$V_{CC} < 4.5V$	4	16	MHz		
Input clock cycle	$t_{CYLH}$		$V_{CC} \geq 4.5V$	50	250	ns	When using external clock	
			$V_{CC} < 4.5V$	62.5	250	ns		
Input clock pulse width	-			$P_{WH}/t_{CYLH}$ , $P_{WL}/t_{CYLH}$	45	55	%	When using external clock
Input clock rising time and falling time	$t_{CF}$ , $t_{CR}$			-	-	5	ns	When using external clock
Internal operating clock* <sup>1</sup> frequency	$F_{CM}$	-	-	-	20	MHz	Master clock	
	$F_{CC}$	-	-	-	20	MHz	Base clock (HCLK/FCLK)	
	$F_{CP0}$	-	-	-	20	MHz	APB0 bus clock* <sup>2</sup>	
	$F_{CP1}$	-	-	-	20	MHz	APB1 bus clock* <sup>2</sup>	
	$F_{CP2}$	-	-	-	20	MHz	APB2 bus clock* <sup>2</sup>	
Internal operating clock* <sup>1</sup> cycle time	$t_{CYCC}$	-	-	50	-	ns	Base clock (HCLK/FCLK)	
	$t_{CYCP0}$	-	-	50	-	ns	APB0 bus clock* <sup>2</sup>	
	$t_{CYCP1}$	-	-	50	-	ns	APB1 bus clock* <sup>2</sup>	
	$t_{CYCP2}$	-	-	50	-	ns	APB2 bus clock* <sup>2</sup>	

\*1: For more information about each internal operating clock, see "Chapter: Clock" in "FM3 Family PERIPHERAL MANUAL".

\*2: For about each APB bus which each peripheral is connected to, see "■BLOCK DIAGRAM" in this data sheet.

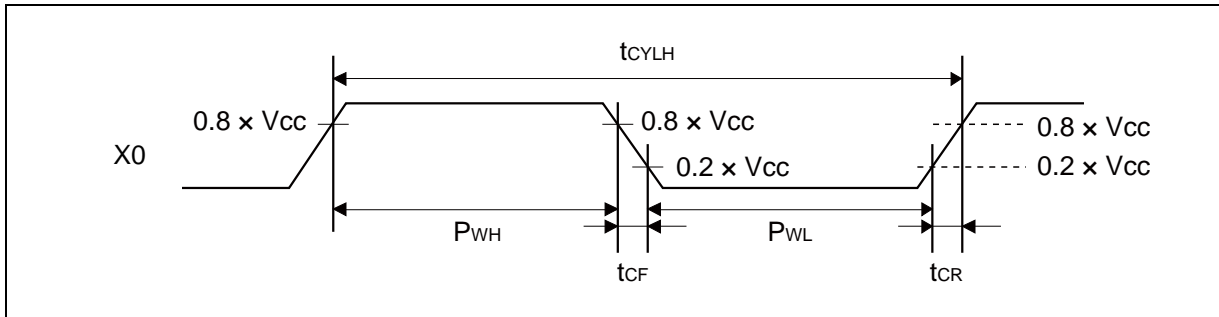

# MB9A130N Series

## (2) Sub Clock Input Characteristics

( $V_{CC} = 1.8V$  to  $5.5V$ ,  $V_{SS} = 0V$ ,  $T_a = -40^{\circ}C$  to  $+85^{\circ}C$ )

Parameter	Symbol	Pin name	Conditions	Value			Unit	Remarks
				Min	Typ	Max		
Input frequency	$F_{CL}$	X0A, X1A	-	-	32.768	-	kHz	When crystal oscillator is connected
			-	32	-	100		kHz
Input clock cycle	$t_{CYLL}$		-	10	-	31.25	$\mu s$	When using external clock
Input clock pulse width	-		$P_{WH}/t_{CYLL}$ , $P_{WL}/t_{CYLL}$	45	-	55	%	When using external clock

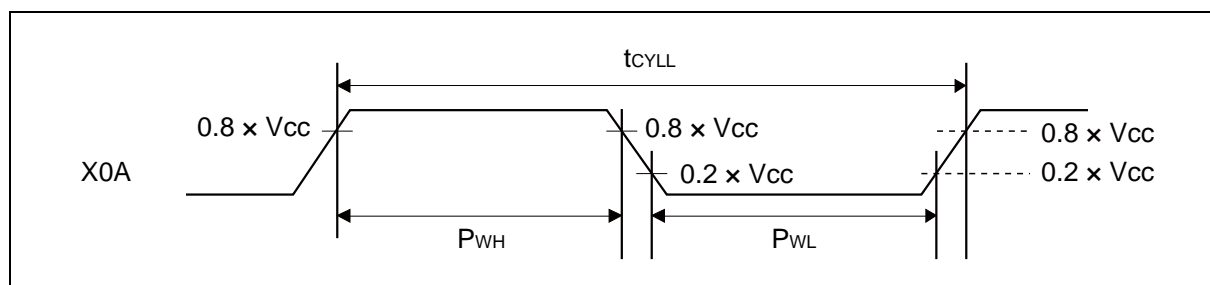

## (3) Built-in CR Oscillation Characteristics

- Built-in high-speed CR

( $V_{CC} = 1.8V$  to  $5.5V$ ,  $V_{SS} = 0V$ ,  $T_a = -40^{\circ}C$  to  $+85^{\circ}C$ )

Parameter	Symbol	Conditions	Value			Unit	Remarks	
			Min	Typ	Max			
Clock frequency	$F_{CRH}$	$V_{CC} \geq 2.2V$	$T_a = +25^{\circ}C$	3.92	4	4.08	MHz	When trimming*
			$T_a = -40^{\circ}C$ to $+85^{\circ}C$	3.8	4	4.2		
			$T_a = -40^{\circ}C$ to $+85^{\circ}C$	2.3	-	7.03		When not trimming
		$V_{CC} < 2.2V$	$T_a = +25^{\circ}C$	3.4	4	4.6	MHz	When trimming*
			$T_a = -40^{\circ}C$ to $+85^{\circ}C$	3.16	4	4.84		
			$T_a = -40^{\circ}C$ to $+85^{\circ}C$	2.3	-	7.03		When not trimming

\*: In the case of using the values in CR trimming area of Flash memory at shipment for frequency trimming.

- Built-in low-speed CR

( $V_{CC} = 1.8V$  to  $5.5V$ ,  $V_{SS} = 0V$ ,  $T_a = -40^{\circ}C$  to  $+85^{\circ}C$ )

Parameter	Symbol	Conditions	Value			Unit	Remarks
			Min	Typ	Max		
Clock frequency	$F_{CRL}$	-	50	100	150	kHz	

## (4-1) Operating Conditions of Main PLL (In the case of using main clock for input of PLL)

( $V_{CC} = 1.8V$  to  $5.5V$ ,  $V_{SS} = 0V$ ,  $T_a = -40^{\circ}C$  to  $+85^{\circ}C$ )

Parameter	Symbol	Value			Unit	Remarks
		Min	Typ	Max		
PLL oscillation stabilization wait time* <sup>1</sup> (LOCK UP time)	$t_{LOCK}$	200	-	-	$\mu s$	
PLL input clock frequency	$F_{PLLI}$	4	-	20	MHz	
PLL multiplication rate	-	1	-	5	multiplier	
PLL macro oscillation clock frequency	$F_{PLLO}$	10	-	20	MHz	
Main PLL clock frequency* <sup>2</sup>	$F_{CLKPLL}$	-	-	20	MHz	

\*1: Time from when the PLL starts operating until the oscillation stabilizes.

\*2: For more information about Main PLL clock (CLKPLL), see "Chapter: Clock" in "FM3 Family PERIPHERAL MANUAL".

## (4-2) Operating Conditions of Main PLL (In the case of using the built-in high-speed CR for the input clock of the main PLL)

( $V_{CC} = 2.2V$  to  $5.5V$ ,  $V_{SS} = 0V$ ,  $T_a = -40^{\circ}C$  to  $+85^{\circ}C$ )

Parameter	Symbol	Value			Unit	Remarks
		Min	Typ	Max		
PLL oscillation stabilization wait time* <sup>1</sup> (LOCK UP time)	$t_{LOCK}$	200	-	-	$\mu s$	
PLL input clock frequency	$F_{PLLI}$	3.8	4	4.2	MHz	
PLL multiplication rate	-	3	-	4	multiplier	
PLL macro oscillation clock frequency	$F_{PLLO}$	11.4	-	16.8	MHz	
Main PLL clock frequency* <sup>2</sup>	$F_{CLKPLL}$	-	-	16.8	MHz	

\*1: Time from when the PLL starts operating until the oscillation stabilizes.

\*2: For more information about Main PLL clock (CLKPLL), see "Chapter: Clock" in "FM3 Family PERIPHERAL MANUAL".

Note: Make sure to input to the main PLL source clock, the high-speed CR clock (CLKHC) that the frequency has been trimmed.

## (5) Reset Input Characteristics

( $V_{CC} = 1.8V$  to  $5.5V$ ,  $V_{SS} = 0V$ ,  $T_a = -40^{\circ}C$  to  $+85^{\circ}C$ )

Parameter	Symbol	Pin name	Conditions	Value		Unit	Remarks
				Min	Max		
Reset input time	$t_{INITX}$	INITX	-	500	-	ns	
				1.5	-	ms	During RTC mode or STOP mode
				1.5	-	ms	During deep standby mode

# MB9A130N Series

## (6) Power-on Reset Timing

( $V_{CC} = 1.8V$  to  $5.5V$ ,  $V_{SS} = 0V$ ,  $T_a = -40^{\circ}C$  to  $+85^{\circ}C$ )

Parameter	Symbol	Pin name	Value			Unit	Remarks
			Min	Typ	Max		
Power supply rising time	dV/dt	VCC	0.1	-	-	V/ms	
Power supply shut down time	Toff		1	-	-	ms	
Reset release voltage	Vdeth		1.44	1.60	1.76	V	When voltage rises
Reset detection voltage	Vdetl		1.39	1.55	1.71	V	When voltage drops
Reset release delay time	Tond		-	-	10	ms	$dV/dt \geq 0.1mV/\mu s$
Reset detection delay time	Toffd		-	-	0.4	ms	$dV/dt \geq -0.04mV/\mu s$

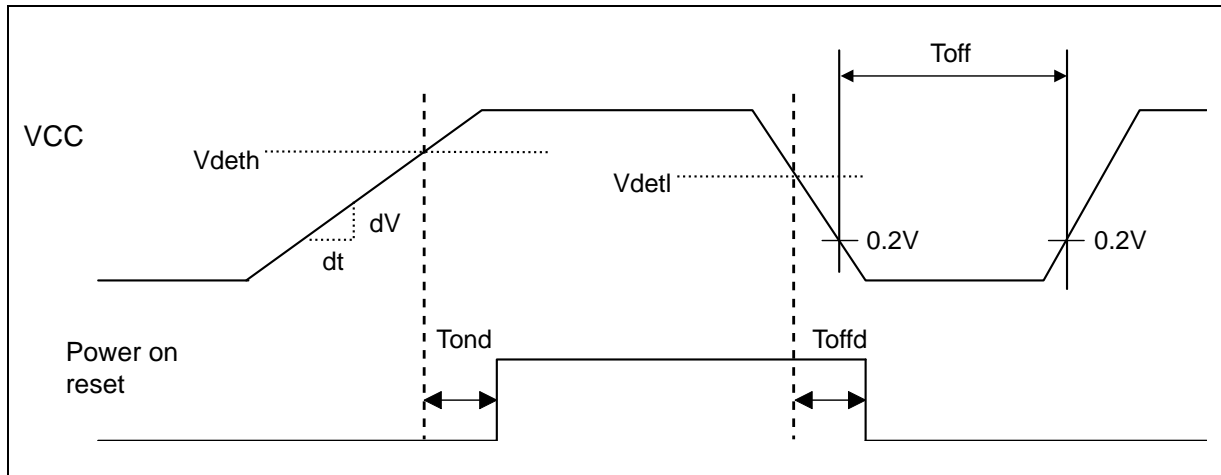

## (7) Base Timer Input Timing

- Timer input timing

( $V_{CC} = 1.8V$  to  $5.5V$ ,  $V_{SS} = 0V$ ,  $T_a = -40^{\circ}C$  to  $+85^{\circ}C$ )

Parameter	Symbol	Pin name	Conditions	Value		Unit	Remarks
				Min	Max		
Input pulse width	$t_{TIWH}$ , $t_{TIWL}$	TIOAn/TIOBn (when using as ECK, TIN)	-	$2t_{CYCP}$	-	ns	

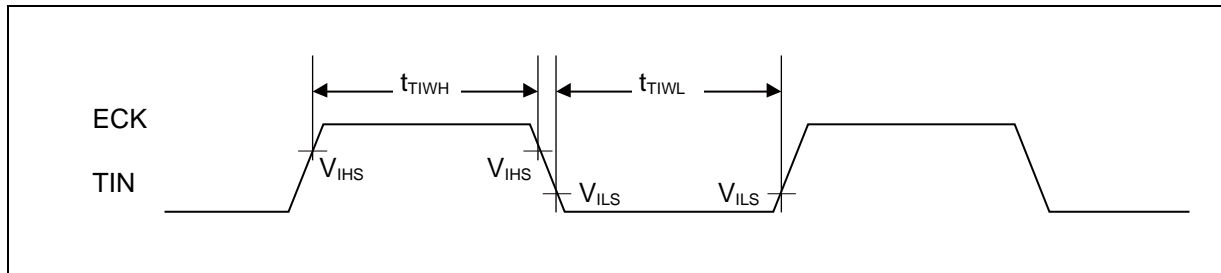

- Trigger input timing

( $V_{CC} = 1.8V$  to  $5.5V$ ,  $V_{SS} = 0V$ ,  $T_a = -40^{\circ}C$  to  $+85^{\circ}C$ )

Parameter	Symbol	Pin name	Conditions	Value		Unit	Remarks
				Min	Max		
Input pulse width	$t_{TRGH}$ , $t_{TRGL}$	TIOAn/TIOBn (when using as TGIN)	-	$2t_{CYCP}$	-	ns	

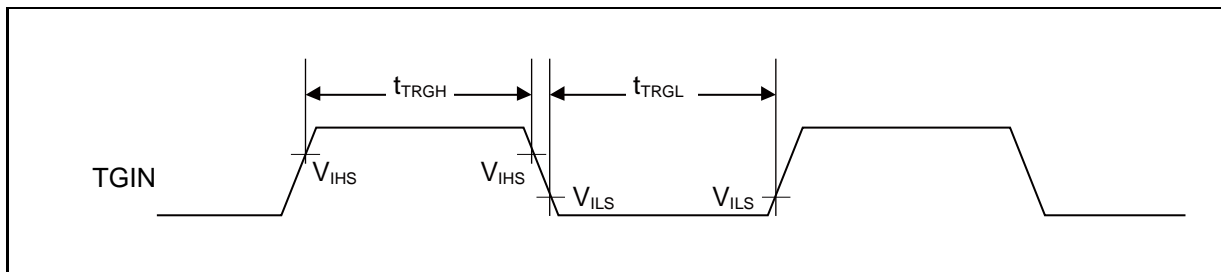

Note:  $t_{CYCP}$  indicates the APB bus clock cycle time. About the APB bus number which the base timer is connected to, see "■BLOCK DIAGRAM" in this data sheet.

# MB9A130N Series

## (8) UART Timing

- Synchronous serial (SPI = 0, SCINV = 0)

(V<sub>CC</sub> = 1.8V to 5.5V, V<sub>SS</sub> = 0V, Ta = - 40°C to + 85°C)

Parameter	Symbol	Pin name	Conditions	V <sub>CC</sub> < 2.7V		2.7V ≤ V <sub>CC</sub> < 4.5V		V <sub>CC</sub> ≥ 4.5V		Unit
				Min	Max	Min	Max	Min	Max	
Serial clock cycle time	t <sub>SCYC</sub>	SCK <sub>X</sub>	Internal shift clock operation	4t <sub>CYCP</sub>	-	4t <sub>CYCP</sub>	-	4t <sub>CYCP</sub>	-	ns
SCK ↓ → SOT delay time	t <sub>SLOVI</sub>	SCK <sub>X</sub> , SOT <sub>X</sub>		-40	+40	-30	+30	-20	+20	ns
SIN → SCK ↑ setup time	t <sub>IVSHI</sub>	SCK <sub>X</sub> , SIN <sub>X</sub>		75	-	50	-	30	-	ns
SCK ↑ → SIN hold time	t <sub>SHIXI</sub>	SCK <sub>X</sub> , SIN <sub>X</sub>		0	-	0	-	0	-	ns
Serial clock "L" pulse width	t <sub>SLSH</sub>	SCK <sub>X</sub>	External shift clock operation	2t <sub>CYCP</sub> - 10	-	2t <sub>CYCP</sub> - 10	-	2t <sub>CYCP</sub> - 10	-	ns
Serial clock "H" pulse width	t <sub>SHSL</sub>	SCK <sub>X</sub>		t <sub>CYCP</sub> + 10	-	t <sub>CYCP</sub> + 10	-	t <sub>CYCP</sub> + 10	-	ns
SCK ↓ → SOT delay time	t <sub>SLOVE</sub>	SCK <sub>X</sub> , SOT <sub>X</sub>		-	75	-	50	-	30	ns
SIN → SCK ↑ setup time	t <sub>IVSHE</sub>	SCK <sub>X</sub> , SIN <sub>X</sub>		10	-	10	-	10	-	ns
SCK ↑ → SIN hold time	t <sub>SHIXE</sub>	SCK <sub>X</sub> , SIN <sub>X</sub>		20	-	20	-	20	-	ns
SCK falling time	t <sub>F</sub>	SCK <sub>X</sub>		-	5	-	5	-	5	ns
SCK rising time	t <sub>R</sub>	SCK <sub>X</sub>		-	5	-	5	-	5	ns

Notes: • The above characteristics apply to CLK synchronous mode.

- t<sub>CYCP</sub> indicates the APB bus clock cycle time.  
About the APB bus number which UART is connected to, see "■BLOCK DIAGRAM" in this data sheet.
- These characteristics only guarantee the same relocate port number.  
For example, the combination of SCLK<sub>x\_0</sub> and SOT<sub>x\_1</sub> is not guaranteed.
- When the external load capacitance C<sub>L</sub> = 50pF.

# MB9A130N Series

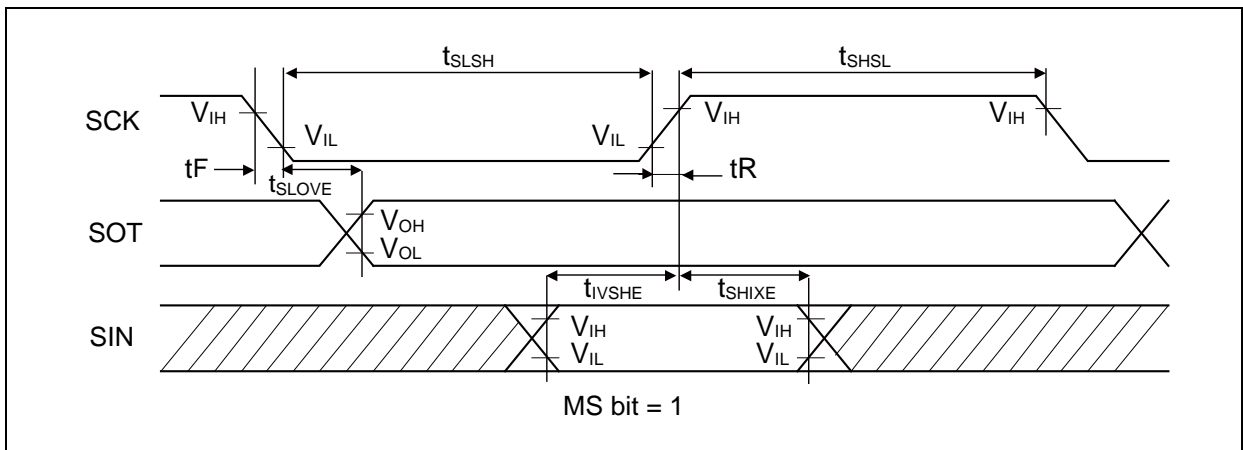
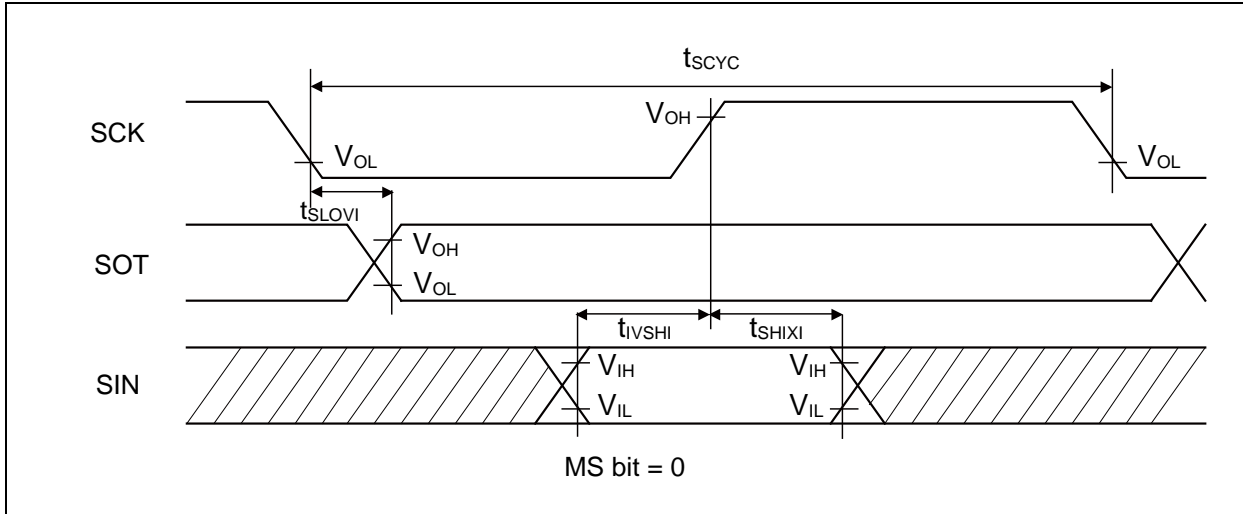

# MB9A130N Series

- Synchronous serial (SPI = 0, SCINV = 1)

( $V_{CC} = 1.8V$  to  $5.5V$ ,  $V_{SS} = 0V$ ,  $T_a = -40^{\circ}C$  to  $+85^{\circ}C$ )

Parameter	Symbol	Pin name	Conditions	$V_{CC} < 2.7V$		$2.7V \leq V_{CC} < 4.5V$		$V_{CC} \geq 4.5V$		Unit
				Min	Max	Min	Max	Min	Max	
Serial clock cycle time	$t_{SCYC}$	SCK <sub>x</sub>	Internal shift clock operation	$4t_{CYCP}$	-	$4t_{CYCP}$	-	$4t_{CYCP}$	-	ns
SCK $\uparrow$ $\rightarrow$ SOT delay time	$t_{SHOVI}$	SCK <sub>x</sub> , SOT <sub>x</sub>		-40	+40	-30	+30	-20	+20	ns
SIN $\rightarrow$ SCK $\downarrow$ setup time	$t_{IVSLI}$	SCK <sub>x</sub> , SIN <sub>x</sub>		75	-	50	-	30	-	ns
SCK $\downarrow$ $\rightarrow$ SIN hold time	$t_{SLIXI}$	SCK <sub>x</sub> , SIN <sub>x</sub>		0	-	0	-	0	-	ns
Serial clock "L" pulse width	$t_{SLSH}$	SCK <sub>x</sub>	External shift clock operation	$2t_{CYCP} - 10$	-	$2t_{CYCP} - 10$	-	$2t_{CYCP} - 10$	-	ns
Serial clock "H" pulse width	$t_{SHSL}$	SCK <sub>x</sub>		$t_{CYCP} + 10$	-	$t_{CYCP} + 10$	-	$t_{CYCP} + 10$	-	ns
SCK $\uparrow$ $\rightarrow$ SOT delay time	$t_{SHOVE}$	SCK <sub>x</sub> , SOT <sub>x</sub>		-	75	-	50	-	30	ns
SIN $\rightarrow$ SCK $\downarrow$ setup time	$t_{IVSLE}$	SCK <sub>x</sub> , SIN <sub>x</sub>		10	-	10	-	10	-	ns
SCK $\downarrow$ $\rightarrow$ SIN hold time	$t_{SLIXE}$	SCK <sub>x</sub> , SIN <sub>x</sub>		20	-	20	-	20	-	ns
SCK falling time	tF	SCK <sub>x</sub>		-	5	-	5	-	5	ns
SCK rising time	tR	SCK <sub>x</sub>		-	5	-	5	-	5	ns

Notes: • The above characteristics apply to CLK synchronous mode.

- $t_{CYCP}$  indicates the APB bus clock cycle time.  
About the APB bus number which UART is connected to, see "■BLOCK DIAGRAM" in this data sheet.
- These characteristics only guarantee the same relocate port number.  
For example, the combination of SCLK<sub>x\_0</sub> and SOT<sub>x\_1</sub> is not guaranteed.
- When the external load capacitance  $C_L = 50pF$ .

# MB9A130N Series

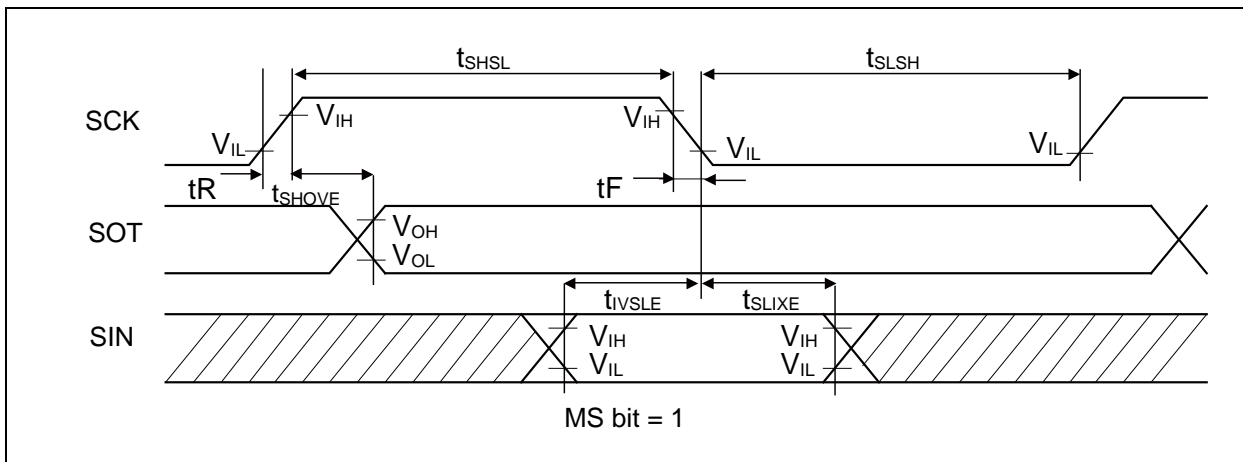
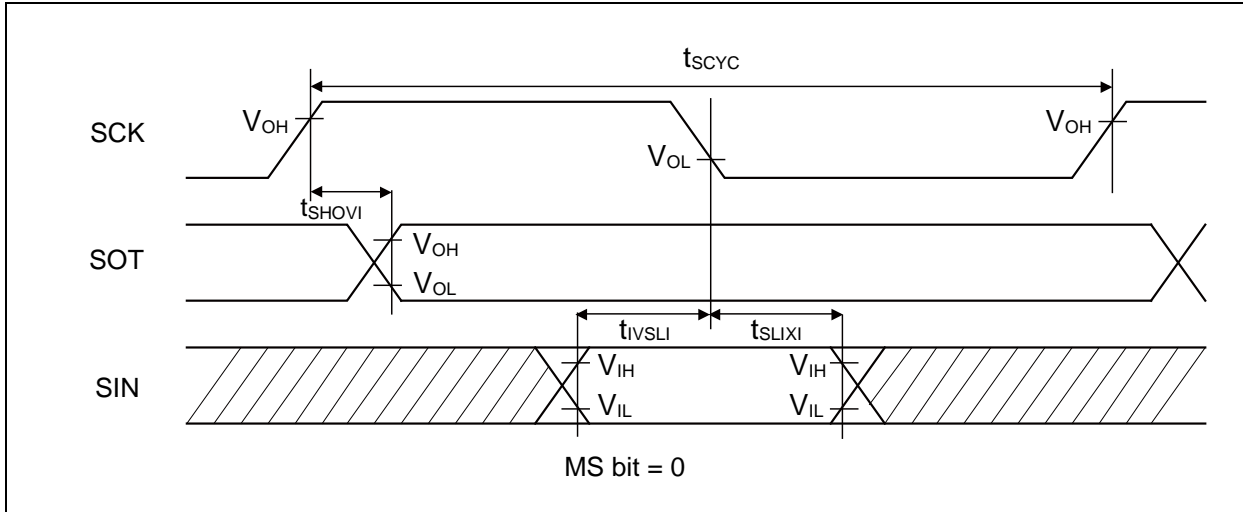

# MB9A130N Series

- Synchronous serial (SPI = 1, SCINV = 0)

( $V_{CC} = 1.8V$  to  $5.5V$ ,  $V_{SS} = 0V$ ,  $T_a = -40^{\circ}C$  to  $+85^{\circ}C$ )

Parameter	Symbol	Pin name	Conditions	$V_{CC} < 2.7V$		$2.7V \leq V_{CC} < 4.5V$		$V_{CC} \geq 4.5V$		Unit
				Min	Max	Min	Max	Min	Max	
Serial clock cycle time	$t_{SCYC}$	SCK <sub>x</sub>	Internal shift clock operation	$4t_{CYCP}$	-	$4t_{CYCP}$	-	$4t_{CYCP}$	-	ns
SCK $\uparrow$ $\rightarrow$ SOT delay time	$t_{SHOVI}$	SCK <sub>x</sub> , SOT <sub>x</sub>		-40	+40	-30	+30	-20	+20	ns
SIN $\rightarrow$ SCK $\downarrow$ setup time	$t_{IVSLI}$	SCK <sub>x</sub> , SIN <sub>x</sub>		75	-	50	-	30	-	ns
SCK $\downarrow$ $\rightarrow$ SIN hold time	$t_{SLIXI}$	SCK <sub>x</sub> , SIN <sub>x</sub>		0	-	0	-	0	-	ns
SOT $\rightarrow$ SCK $\downarrow$ delay time	$t_{SOVLI}$	SCK <sub>x</sub> , SOT <sub>x</sub>		$2t_{CYCP} - 30$	-	$2t_{CYCP} - 30$	-	$2t_{CYCP} - 30$	-	ns
Serial clock "L" pulse width	$t_{SLSH}$	SCK <sub>x</sub>	External shift clock operation	$2t_{CYCP} - 10$	-	$2t_{CYCP} - 10$	-	$2t_{CYCP} - 10$	-	ns
Serial clock "H" pulse width	$t_{SHSL}$	SCK <sub>x</sub>		$t_{CYCP} + 10$	-	$t_{CYCP} + 10$	-	$t_{CYCP} + 10$	-	ns
SCK $\uparrow$ $\rightarrow$ SOT delay time	$t_{SHOVE}$	SCK <sub>x</sub> , SOT <sub>x</sub>		-	75	-	50	-	30	ns
SIN $\rightarrow$ SCK $\downarrow$ setup time	$t_{IVSLE}$	SCK <sub>x</sub> , SIN <sub>x</sub>		10	-	10	-	10	-	ns
SCK $\downarrow$ $\rightarrow$ SIN hold time	$t_{SLIXE}$	SCK <sub>x</sub> , SIN <sub>x</sub>		20	-	20	-	20	-	ns
SCK falling time	tF	SCK <sub>x</sub>		-	5	-	5	-	5	ns
SCK rising time	tR	SCK <sub>x</sub>		-	5	-	5	-	5	ns

Notes: • The above characteristics apply to CLK synchronous mode.

- $t_{CYCP}$  indicates the APB bus clock cycle time.  
About the APB bus number which UART is connected to, see "■BLOCK DIAGRAM" in this data sheet.
- These characteristics only guarantee the same relocate port number.  
For example, the combination of SCLK<sub>x\_0</sub> and SOT<sub>x\_1</sub> is not guaranteed.
- When the external load capacitance  $C_L = 50pF$ .

# MB9A130N Series

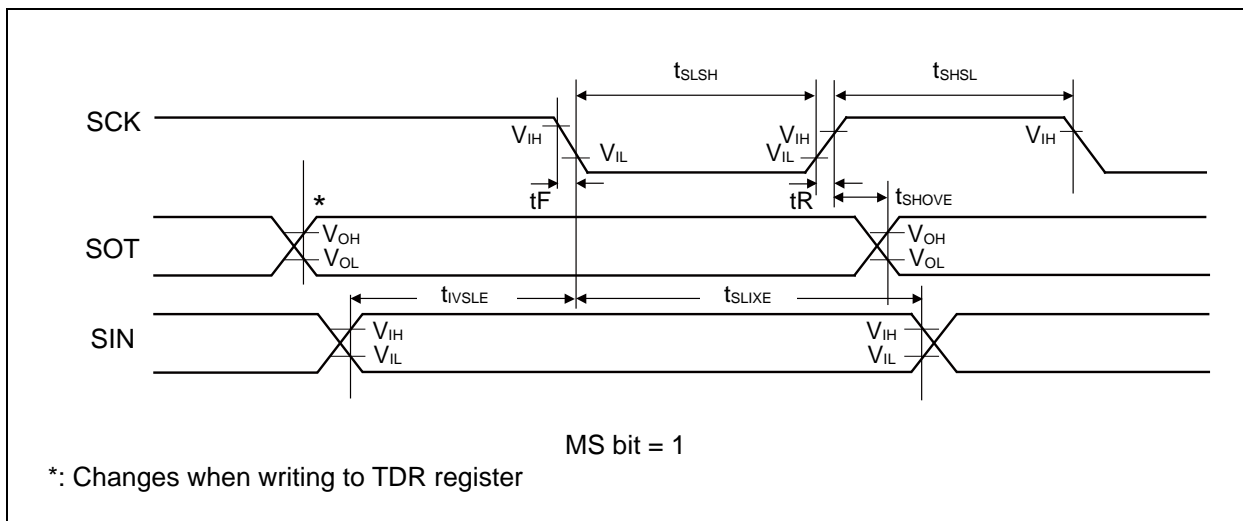
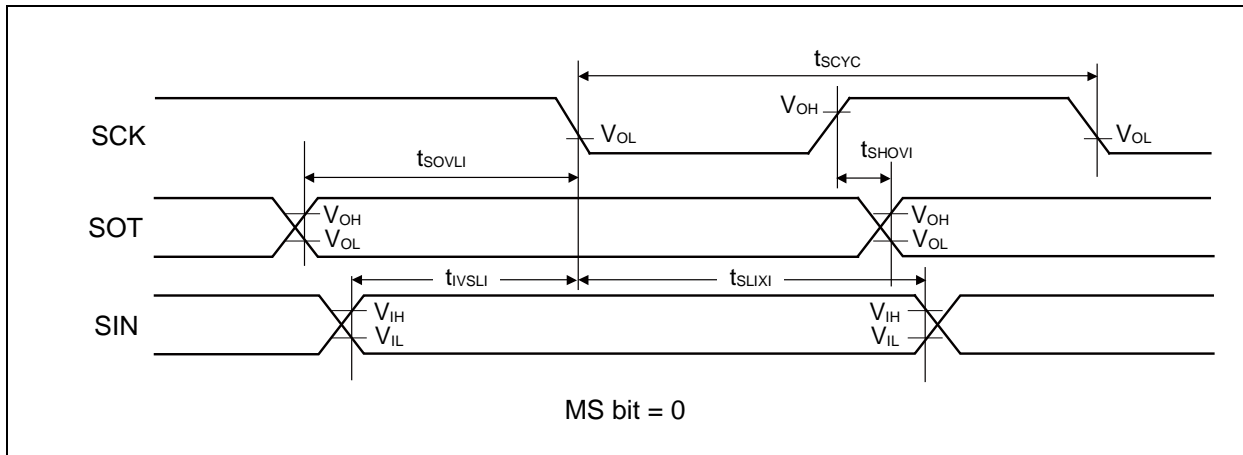

# MB9A130N Series

- Synchronous serial (SPI = 1, SCINV = 1)

( $V_{CC} = 1.8V$  to  $5.5V$ ,  $V_{SS} = 0V$ ,  $T_a = -40^{\circ}C$  to  $+85^{\circ}C$ )

Parameter	Symbol	Pin name	Conditions	$V_{CC} < 2.7V$		$2.7V \leq V_{CC} < 4.5V$		$V_{CC} \geq 4.5V$		Unit
				Min	Max	Min	Max	Min	Max	
Serial clock cycle time	$t_{SCYC}$	SCK <sub>X</sub>	Internal shift clock operation	$4t_{CYCP}$	-	$4t_{CYCP}$	-	$4t_{CYCP}$	-	ns
SCK ↓ → SOT delay time	$t_{SLOVI}$	SCK <sub>X</sub> , SOT <sub>X</sub>		-40	+40	-30	+30	-20	+20	ns
SIN → SCK ↑ setup time	$t_{IVSHI}$	SCK <sub>X</sub> , SIN <sub>X</sub>		75	-	50	-	30	-	ns
SCK ↑ → SIN hold time	$t_{SHIXI}$	SCK <sub>X</sub> , SIN <sub>X</sub>		0	-	0	-	0	-	ns
SOT → SCK ↑ delay time	$t_{SOVHI}$	SCK <sub>X</sub> , SOT <sub>X</sub>		$2t_{CYCP} - 30$	-	$2t_{CYCP} - 30$	-	$2t_{CYCP} - 30$	-	ns
Serial clock "L" pulse width	$t_{SLSH}$	SCK <sub>X</sub>	External shift clock operation	$2t_{CYCP} - 10$	-	$2t_{CYCP} - 10$	-	$2t_{CYCP} - 10$	-	ns
Serial clock "H" pulse width	$t_{SHSL}$	SCK <sub>X</sub>		$t_{CYCP} + 10$	-	$t_{CYCP} + 10$	-	$t_{CYCP} + 10$	-	ns
SCK ↓ → SOT delay time	$t_{SLOVE}$	SCK <sub>X</sub> , SOT <sub>X</sub>		-	75	-	50	-	30	ns
SIN → SCK ↑ setup time	$t_{IVSHE}$	SCK <sub>X</sub> , SIN <sub>X</sub>		10	-	10	-	10	-	ns
SCK ↑ → SIN hold time	$t_{SHIXE}$	SCK <sub>X</sub> , SIN <sub>X</sub>		20	-	20	-	20	-	ns
SCK falling time	tF	SCK <sub>X</sub>		-	5	-	5	-	5	ns
SCK rising time	tR	SCK <sub>X</sub>		-	5	-	5	-	5	ns

Notes: • The above characteristics apply to CLK synchronous mode.

- $t_{CYCP}$  indicates the APB bus clock cycle time.

About the APB bus number which UART is connected to, see "■BLOCK DIAGRAM" in this data sheet.

- These characteristics only guarantee the same relocate port number.

For example, the combination of SCLK<sub>x\_0</sub> and SOT<sub>x\_1</sub> is not guaranteed.

- When the external load capacitance  $C_L = 50pF$ .

# MB9A130N Series

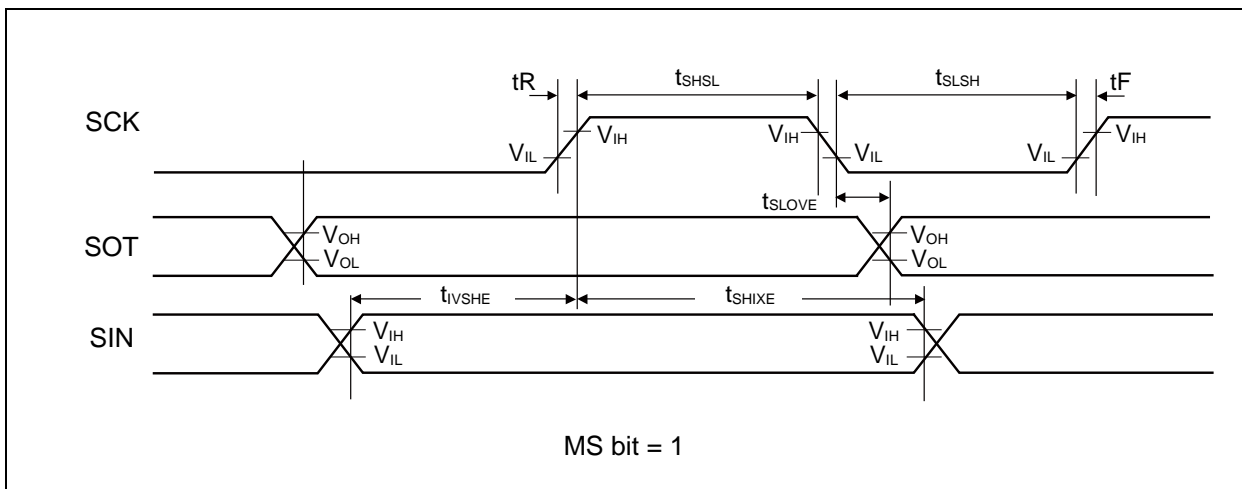
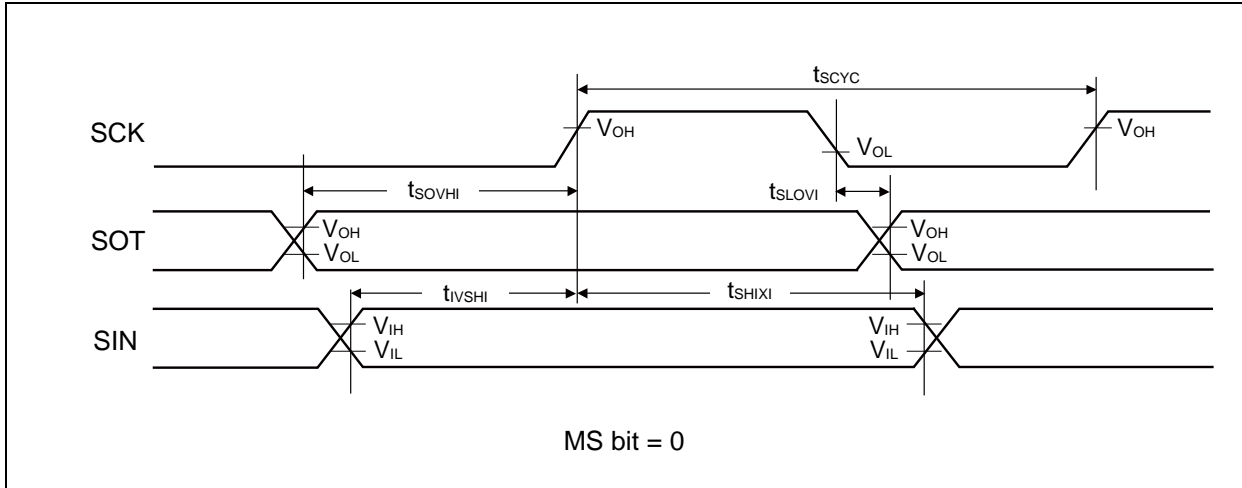

- External clock (EXT = 1) : asynchronous only

( $V_{CC} = 1.8V$  to  $5.5V$ ,  $V_{SS} = 0V$ ,  $T_a = -40^{\circ}C$  to  $+85^{\circ}C$ )

Parameter	Symbol	Conditions	Value		Unit	Remarks
			Min	Max		
Serial clock "L" pulse width	$t_{SLSH}$	$C_L = 50pF$	$t_{CYCP} + 10$	-	ns	
Serial clock "H" pulse width	$t_{SHSL}$		$t_{CYCP} + 10$	-	ns	
SCK falling time	$t_F$		-	5	ns	
SCK rising time	$t_R$		-	5	ns	

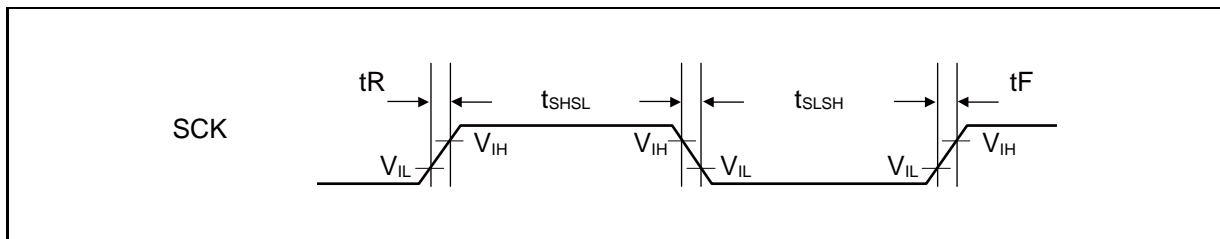

# MB9A130N Series

## (9) External Input Timing

( $V_{CC} = 1.8V$  to  $5.5V$ ,  $V_{SS} = 0V$ ,  $T_a = -40^{\circ}C$  to  $+85^{\circ}C$ )

Parameter	Symbol	Pin name	Conditions	Value		Unit	Remarks
				Min	Max		
Input pulse width	$t_{INH}$ , $t_{INL}$	ADTG	-	$2t_{CYCP}^{*1}$	-	ns	A/D converter trigger input
		FRCKx					Free-run timer input clock
		ICxx					Input capture
		DTTIXX	-	$2t_{CYCP}^{*1}$	-	ns	Waveform generator
		IGTRG	-	$2t_{CYCP}^{*1}$	-	ns	PPG IGBT mode
		INT00 to INT15, NMIX	-	$2t_{CYCP} + 100^{*1}$	-	ns	External interrupt, NMI
		500 <sup>*2</sup>	-	ns			
WKUPx	-	500 <sup>*3</sup>	-	ns	Deep standby wake up		

\*1 :  $t_{CYCP}$  indicates the APB bus clock cycle time except stop when in stop mode, etc.

About the APB bus number which the A/D converter, Multi-function Timer, PPG, External interrupt, Deep standby mode Controller are connected to, see "■BLOCK DIAGRAM" in this data sheet.

\*2 : When in stop mode, in timer mode.

\*3 : When in deep standby STOP mode, in deep standby RTC mode.

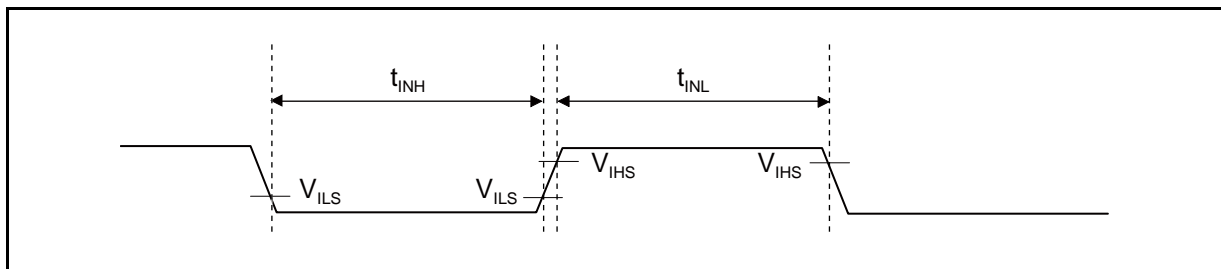

## (10) I<sup>2</sup>C Timing

(V<sub>CC</sub> = 1.8V to 5.5V, V<sub>SS</sub> = 0V, T<sub>a</sub> = -40°C to +85°C)

Parameter	Symbol	Conditions	Typical mode		High-speed mode		Unit	Remarks
			Min	Max	Min	Max		
SCL clock frequency	F <sub>SCL</sub>		0	100	0	400	kHz	
(Repeated) START condition hold time SDA ↓ → SCL ↓	t <sub>HDSTA</sub>	C <sub>L</sub> = 50pF, R = (V <sub>p</sub> /I <sub>OL</sub> )* <sup>1</sup>	4.0	-	0.6	-	μs	
SCL clock "L" width	t <sub>LOW</sub>		4.7	-	1.3	-	μs	
SCL clock "H" width	t <sub>HIGH</sub>		4.0	-	0.6	-	μs	
(Repeated) START condition setup time SCL ↑ → SDA ↓	t <sub>SUSTA</sub>		4.7	-	0.6	-	μs	
Data hold time SCL ↓ → SDA ↓ ↑	t <sub>HDDAT</sub>		0	3.45* <sup>2</sup>	0	0.9* <sup>3</sup>	μs	
Data setup time SDA ↓ ↑ → SCL ↑	t <sub>SUDAT</sub>		250	-	100	-	ns	
STOP condition setup time SCL ↑ → SDA ↑	t <sub>SUSTO</sub>		4.0	-	0.6	-	μs	
Bus free time between "STOP condition" and "START condition"	t <sub>BUF</sub>		4.7	-	1.3	-	μs	
Noise filter	t <sub>SP</sub>		-	2 t <sub>CYCP</sub> * <sup>4</sup>	-	2 t <sub>CYCP</sub> * <sup>4</sup>	-	ns

\*1 : R and C<sub>L</sub> represent the pull-up resistor and load capacitance of the SCL and SDA lines, respectively.

V<sub>p</sub> indicates the power supply voltage of the pull-up resistor and I<sub>OL</sub> indicates V<sub>OL</sub> guaranteed current.

\*2 : The maximum t<sub>HDDAT</sub> must satisfy that it does not extend at least "L" period (t<sub>LOW</sub>) of device's SCL signal.

\*3 : A high-speed mode I<sup>2</sup>C bus device can be used on a standard mode I<sup>2</sup>C bus system as long as the device satisfies the requirement of "t<sub>SUDAT</sub> ≥ 250 ns".

\*4 : t<sub>CYCP</sub> is the APB bus clock cycle time. About the APB bus number which I<sup>2</sup>C is connected to, see "■BLOCK DIAGRAM" in this data sheet. To use I<sup>2</sup>C, set the peripheral bus clock at 8 MHz or more.

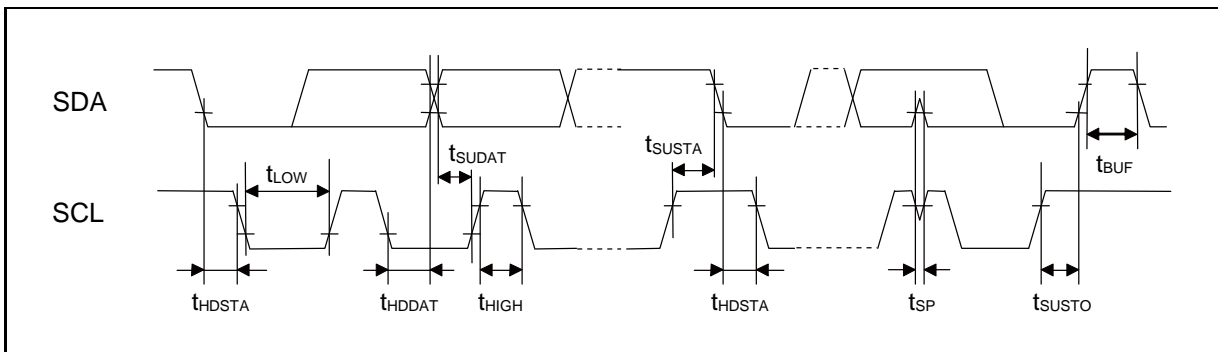

# MB9A130N Series

## (11) JTAG Timing

( $V_{CC} = 1.8V$  to  $5.5V$ ,  $V_{SS} = 0V$ ,  $T_a = -40^{\circ}C$  to  $+85^{\circ}C$ )

Parameter	Symbol	Pin name	Conditions	Value		Unit	Remarks
				Min	Max		
TMS,TDI setup time	$t_{JTAGS}$	TCK, TMS,TDI	$V_{CC} \geq 4.5V$	15	-	ns	
			$V_{CC} < 4.5V$				
TMS,TDI hold time	$t_{JTAGH}$	TCK, TMS,TDI	$V_{CC} \geq 4.5V$	15	-	ns	
			$V_{CC} < 4.5V$				
TDO delay time	$t_{JTAGD}$	TCK, TDO	$V_{CC} \geq 4.5V$	-	30	ns	
			$2.7V \leq V_{CC} < 4.5V$	-	45		
			$V_{CC} < 2.7V$	-	60		

Note: When the external load capacitance  $C_L = 50pF$ .

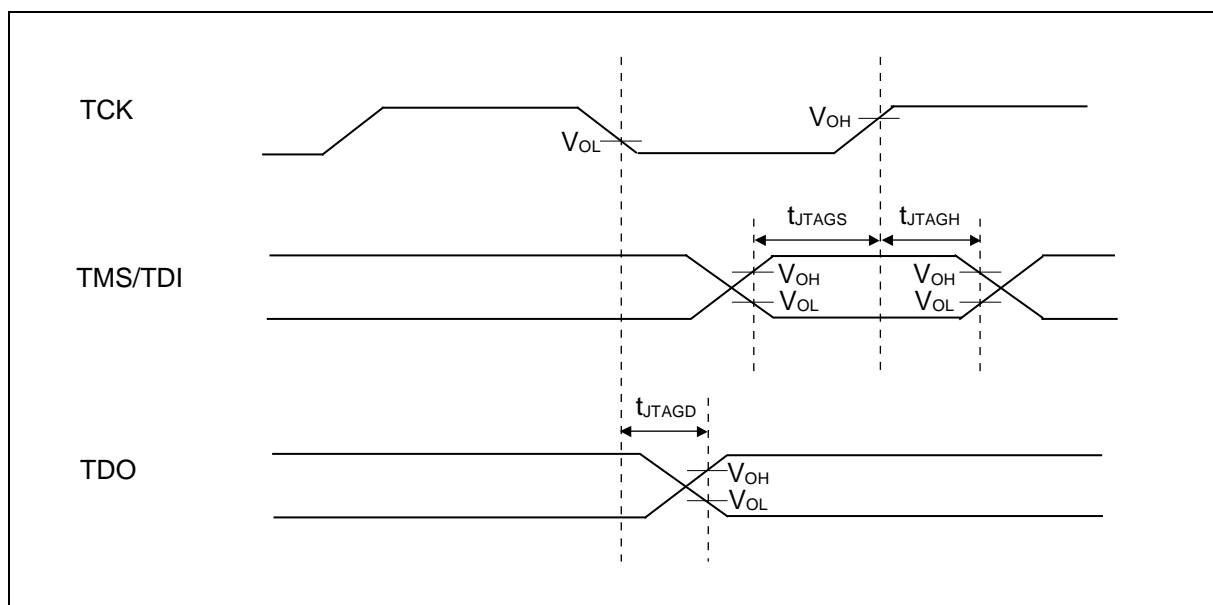

## 5. 12-bit A/D Converter

### • Electrical Characteristics for the A/D Converter

( $V_{CC} = AV_{CC} = 1.8V$  to  $5.5V$ ,  $V_{SS} = AV_{SS} = 0V$ ,  $T_a = -40^{\circ}C$  to  $+85^{\circ}C$ )

Parameter	Symbol	Pin name	Value			Unit	Remarks
			Min	Typ	Max		
Resolution	-	-	-	-	12	bit	
Non linearity error	-	-	-3.0	-	+3.0	LSB	$AV_{CC} \geq 2.7V$
			-4.0	-	+4.0	LSB	$AV_{CC} < 2.7V$
Differential linearity error	-	-	-1.9	-	+1.9	LSB	$AV_{CC} \geq 2.7V$
			-2.9	-	+2.9	LSB	$AV_{CC} < 2.7V$
Zero transition voltage	$V_{0T}$	AN00 to AN15	-20	-	+20	mV	
Full-scale transition voltage	$V_{FST}$	AN00 to AN15	AVRH-20	-	AVRH+20	mV	
Conversion time	-	-	$1.0^{*1}$	-	-	$\mu s$	$AV_{CC} \geq 2.7V$
Sampling time	$T_s$	-	$*2$	-	10	$\mu s$	
Compare clock cycle <sup>*3</sup>	$T_{cck}$	-	50	-	1000	ns	$AV_{CC} \geq 2.7V$
			200				$AV_{CC} < 2.7V$
Period of operation enable state transitions	$T_{stt}$	-	1.0	-	-	$\mu s$	
Power supply current (analog + digital)	-	AVCC	-	1.4	2.5	mA	A/D operation
			-	0.1	0.35	$\mu A$	A/D stop
Reference power supply current (between AVRH and AVSS)	-	AVRH	-	0.5	1.5	mA	A/D operation AVRH=5.5V
			-	0.1	0.3	$\mu A$	A/D stop
Analog input capacity	$C_{AIN}$	-	-	-	15	pF	
Analog input resistor	$R_{AIN}$	-	-	-	0.9	k $\Omega$	$AV_{CC} \geq 4.5V$
					1.6		$2.7V \leq AV_{CC} < 4.5V$
					4.0		$AV_{CC} < 2.7V$
Interchannel disparity	-	-	-	-	4	LSB	
Analog port input current	-	AN00 to AN15	-	-	0.3	$\mu A$	
Analog input voltage	-	AN00 to AN15	AVSS	-	AVRH	V	
Reference voltage	-	AVRH	2.7	-	AVCC	V	$AV_{CC} \geq 2.7V$
			AVCC				$AV_{CC} < 2.7V$

\*1: The conversion time is the value of sampling time ( $T_s$ ) + compare time ( $T_c$ ).

The condition of the minimum conversion time is, the value of sampling time: 300ns, the value of compare time: 700ns ( $AV_{CC} \geq 2.7V$ ).

Ensure that it satisfies the value of the sampling time ( $T_s$ ) and compare clock cycle ( $T_{cck}$ ).

For setting<sup>\*4</sup> of the sampling time and compare clock cycle, see "Chapter: A/D Converter" in "FM3 Family PERIPHERAL MANUAL Analog Macro Part".

\*2: A necessary sampling time changes by external impedance.

Ensure to set the sampling time to satisfy (Equation 1).

\*3: The compare time ( $T_c$ ) is the value of (Equation 2).

\*4: The A/D Converter register is set at the peripheral clock timing.

The sampling clock and compare clock are set with the base clock (HCLK).

About the APB bus number which the A/D Converter is connected to, see "■BLOCK DIAGRAM" in this data sheet.

# MB9A130N Series

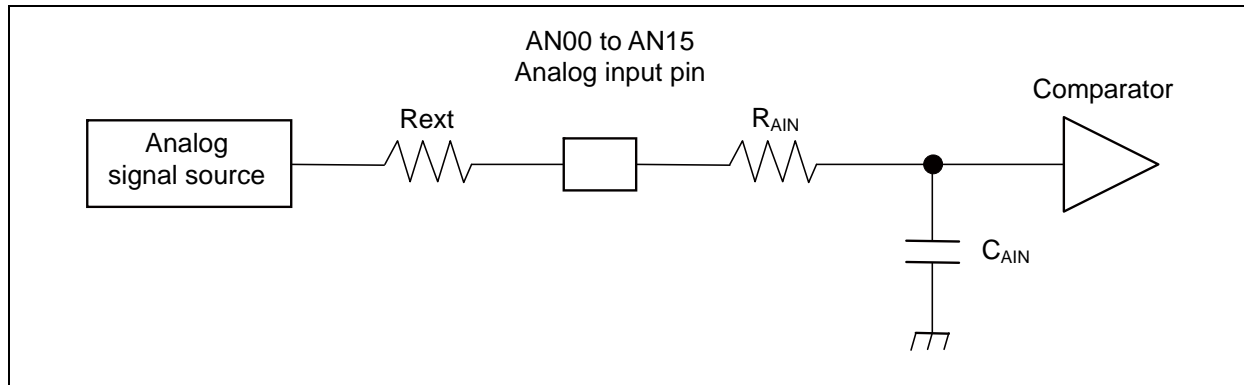

$$\text{(Equation 1) } T_s \geq (R_{AIN} + R_{ext}) \times C_{AIN} \times 9$$

$T_s$  : Sampling time

$R_{AIN}$  : input resistor of A/D = 0.9k $\Omega$  at  $4.5 \leq AVCC \leq 5.5$

input resistor of A/D = 1.6k $\Omega$  at  $2.7 \leq AVCC < 4.5$

input resistor of A/D = 4.0k $\Omega$  at  $1.8 \leq AVCC < 2.7$

$C_{AIN}$  : input capacity of A/D = 15pF at  $1.8 \leq AVCC \leq 5.5$

$R_{ext}$  : Output impedance of external circuit

$$\text{(Equation 2) } T_c = T_{ck} \times 14$$

$T_c$  : Compare time

$T_{ck}$  : Compare clock cycle

## • Definition of 12-bit A/D Converter Terms

- Resolution : Analog variation that is recognized by an A/D converter.
- Linearity error : Deviation of the line between the zero-transition point (0b000000000000←→0b000000000001) and the full-scale transition point (0b111111111110←→0b111111111111) from the actual conversion characteristics.
- Differential linearity error : Deviation from the ideal value of the input voltage that is required to change the output code by 1 LSB.

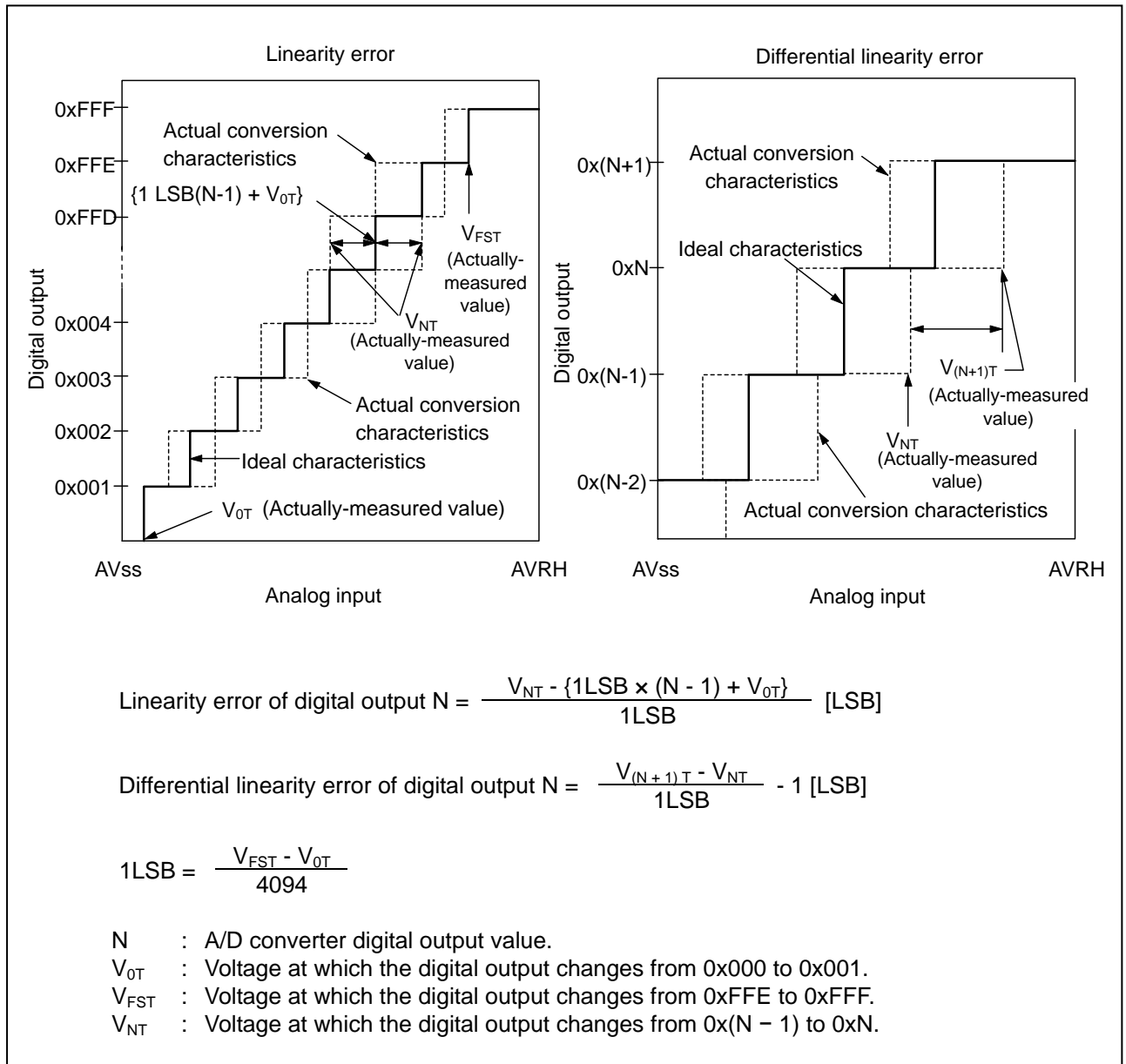

# MB9A130N Series

## 6. 10-bit D/A Converter

- Electrical Characteristics for the D/A Converter

( $V_{CC} = AV_{CC} = 1.8V$  to  $5.5V$ ,  $V_{SS} = AV_{SS} = 0V$ ,  $T_a = -40^{\circ}C$  to  $+85^{\circ}C$ )

Parameter	Symbol	Pin name	Value			Unit	Remarks
			Min	Typ	Max		
Resolution	-	DAx	-	-	10	bit	
Conversion time	tc20		0.37	0.53	0.69	$\mu s$	Load 20pF
	tc100		1.87	2.67	3.47	$\mu s$	Load 100pF
Linearity error* <sup>1</sup>	INL		-4.0	-	+4.0	LSB	
Differential linearity error* <sup>1,*2</sup>	DNL		-0.9	-	+0.9	LSB	
Output Voltage offset	$V_{OFF}$		-	-	10.0	mV	Code is 0x000
			-50.0	-	+5.5	mV	Code is 0x3FF
Analog output impedance	$R_O$		2.45	3.50	4.55	k $\Omega$	D/A operation
			5.0	9.0	-	M $\Omega$	D/A stop
Output undefined period	$t_R$		-	-	250	ns	
Power supply current* <sup>1</sup>	IDDA* <sup>2</sup>	AVCC	190	314	440	$\mu A$	D/A 1ch. operation AV <sub>CC</sub> =3.3V
			285	476	670	$\mu A$	D/A 1ch. operation AV <sub>CC</sub> =5.0V
	IDSAs		-	-	1.0	$\mu A$	D/A stop

\*1: No-load

\*2: Generates the max current by the CODE about 0x200



# MB9A130N Series

## (2) Interrupt of Low-Voltage Detection

- Normal mode

(Ta = - 40°C to + 85°C)

Parameter	Symbol	Conditions	Value			Unit	Remarks
			Min	Typ	Max		
Detected voltage	V <sub>DLI</sub>	SVHI = 0000	1.87	2.00	2.13	V	When voltage drops
Released voltage	V <sub>DHI</sub>		1.97	2.10	2.23		
Detected voltage	V <sub>DLI</sub>	SVHI = 0001	1.96	2.10	2.24	V	When voltage drops
Released voltage	V <sub>DHI</sub>		2.06	2.20	2.34		
Detected voltage	V <sub>DLI</sub>	SVHI = 0010	2.05	2.20	2.35	V	When voltage drops
Released voltage	V <sub>DHI</sub>		2.15	2.30	2.45		
Detected voltage	V <sub>DLI</sub>	SVHI = 0011	2.15	2.30	2.45	V	When voltage drops
Released voltage	V <sub>DHI</sub>		2.25	2.40	2.55		
Detected voltage	V <sub>DLI</sub>	SVHI = 0100	2.24	2.40	2.56	V	When voltage drops
Released voltage	V <sub>DHI</sub>		2.34	2.50	2.66		
Detected voltage	V <sub>DLI</sub>	SVHI = 0101	2.33	2.50	2.67	V	When voltage drops
Released voltage	V <sub>DHI</sub>		2.43	2.60	2.77		
Detected voltage	V <sub>DLI</sub>	SVHI = 0110	2.43	2.60	2.77	V	When voltage drops
Released voltage	V <sub>DHI</sub>		2.53	2.70	2.87		
Detected voltage	V <sub>DLI</sub>	SVHI = 0111	2.61	2.80	2.99	V	When voltage drops
Released voltage	V <sub>DHI</sub>		2.71	2.90	3.09		
Detected voltage	V <sub>DLI</sub>	SVHI = 1000	2.80	3.00	3.20	V	When voltage drops
Released voltage	V <sub>DHI</sub>		2.90	3.10	3.30		
Detected voltage	V <sub>DLI</sub>	SVHI = 1001	2.99	3.20	3.41	V	When voltage drops
Released voltage	V <sub>DHI</sub>		3.09	3.30	3.51		
Detected voltage	V <sub>DLI</sub>	SVHI = 1010	3.36	3.60	3.84	V	When voltage drops
Released voltage	V <sub>DHI</sub>		3.46	3.70	3.94		
Detected voltage	V <sub>DLI</sub>	SVHI = 1011	3.45	3.70	3.95	V	When voltage drops
Released voltage	V <sub>DHI</sub>		3.55	3.80	4.05		
Detected voltage	V <sub>DLI</sub>	SVHI = 1100	3.73	4.00	4.27	V	When voltage drops
Released voltage	V <sub>DHI</sub>		3.83	4.10	4.37		
Detected voltage	V <sub>DLI</sub>	SVHI = 1101	3.83	4.10	4.37	V	When voltage drops
Released voltage	V <sub>DHI</sub>		3.93	4.20	4.47		
Detected voltage	V <sub>DLI</sub>	SVHI = 1110	3.92	4.20	4.48	V	When voltage drops
Released voltage	V <sub>DHI</sub>		4.02	4.30	4.58		
LVD stabilization wait time	T <sub>LVDIW</sub>	-	-	-	633 × t <sub>CYCP</sub> *	μs	
Detection delay time	T <sub>LVDID</sub>	dV/dt ≥ - 4mV/μs	-	-	60	μs	

\* : t<sub>CYCP</sub> indicates the APB2 bus clock cycle time.

# MB9A130N Series

- Low power mode

(Ta = - 40°C to + 85°C)

Parameter	Symbol	Conditions	Value			Unit	Remarks
			Min	Typ	Max		
Detected voltage	V <sub>DLIL</sub>	SVHI = 0000	1.80	2.00	2.20	V	When voltage drops
Released voltage	V <sub>DHIL</sub>		1.90	2.10	2.30	V	When voltage rises
Detected voltage	V <sub>DLIL</sub>	SVHI = 0001	1.89	2.10	2.31	V	When voltage drops
Released voltage	V <sub>DHIL</sub>		1.99	2.20	2.41	V	When voltage rises
Detected voltage	V <sub>DLIL</sub>	SVHI = 0010	1.98	2.20	2.42	V	When voltage drops
Released voltage	V <sub>DHIL</sub>		2.08	2.30	2.52	V	When voltage rises
Detected voltage	V <sub>DLIL</sub>	SVHI = 0011	2.07	2.30	2.53	V	When voltage drops
Released voltage	V <sub>DHIL</sub>		2.17	2.40	2.63	V	When voltage rises
Detected voltage	V <sub>DLIL</sub>	SVHI = 0100	2.16	2.40	2.64	V	When voltage drops
Released voltage	V <sub>DHIL</sub>		2.26	2.50	2.74	V	When voltage rises
Detected voltage	V <sub>DLIL</sub>	SVHI = 0101	2.25	2.50	2.75	V	When voltage drops
Released voltage	V <sub>DHIL</sub>		2.35	2.60	2.85	V	When voltage rises
Detected voltage	V <sub>DLIL</sub>	SVHI = 0110	2.34	2.60	2.86	V	When voltage drops
Released voltage	V <sub>DHIL</sub>		2.44	2.70	2.96	V	When voltage rises
Detected voltage	V <sub>DLIL</sub>	SVHI = 0111	2.52	2.80	3.08	V	When voltage drops
Released voltage	V <sub>DHIL</sub>		2.62	2.90	3.18	V	When voltage rises
Detected voltage	V <sub>DLIL</sub>	SVHI = 1000	2.70	3.00	3.30	V	When voltage drops
Released voltage	V <sub>DHIL</sub>		2.80	3.10	3.40	V	When voltage rises
Detected voltage	V <sub>DLIL</sub>	SVHI = 1001	2.88	3.20	3.52	V	When voltage drops
Released voltage	V <sub>DHIL</sub>		2.98	3.30	3.62	V	When voltage rises
Detected voltage	V <sub>DLIL</sub>	SVHI = 1010	3.24	3.60	3.96	V	When voltage drops
Released voltage	V <sub>DHIL</sub>		3.34	3.70	4.06	V	When voltage rises
Detected voltage	V <sub>DLIL</sub>	SVHI = 1011	3.33	3.70	4.07	V	When voltage drops
Released voltage	V <sub>DHIL</sub>		3.43	3.80	4.17	V	When voltage rises
Detected voltage	V <sub>DLIL</sub>	SVHI = 1100	3.60	4.00	4.40	V	When voltage drops
Released voltage	V <sub>DHIL</sub>		3.70	4.10	4.50	V	When voltage rises
Detected voltage	V <sub>DLIL</sub>	SVHI = 1101	3.69	4.10	4.51	V	When voltage drops
Released voltage	V <sub>DHIL</sub>		3.79	4.20	4.61	V	When voltage rises
Detected voltage	V <sub>DLIL</sub>	SVHI = 1110	3.78	4.20	4.62	V	When voltage drops
Released voltage	V <sub>DHIL</sub>		3.88	4.30	4.72	V	When voltage rises
LVD stabilization wait time	T <sub>LVDILW</sub>	-	-	-	8039 × t <sub>CYCP</sub> *	μs	
Detection/Release delay time	T <sub>LVDILD</sub>	dV/dt ≥ - 0.4mV/μs	-	-	800	μs	

\* : t<sub>CYCP</sub> indicates the APB2 bus clock cycle time.

# MB9A130N Series

## 8. Flash Memory Write/Erase Characteristics

(V<sub>CC</sub> = 2.0V to 5.5V, T<sub>a</sub> = - 40°C to + 85°C)

Parameter		Value			Unit	Remarks
		Min	Typ	Max		
Sector erase time	Large Sector	-	0.6	3.1	s	Excludes write time prior to internal erase
	Small Sector		0.3	1.6		
Half word (16-bit) write time		-	25	400	μs	Not including system-level overhead time.
Chip erase time		-	1.8	9.4	s	Excludes write time prior to internal erase

### Write cycles and data hold time

Erase/write cycles (cycle)	Data hold time (year)	Remarks
1,000	20*	
10,000	10*	
100,000	5*	

\*: This value comes from the technology qualification (using Arrhenius equation to translate high temperature acceleration test result into average temperature value at + 85°C) .

# MB9A130N Series

## ■ ORDERING INFORMATION

Part number	Package
MB9AF131MPMC	Plastic • LQFP(0.5mm pitch), 80-pin (FPT-80P-M37)
MB9AF132MPMC	
MB9AF131MPMC1	Plastic • LQFP(0.65mm pitch), 80-pin (FPT-80P-M40)
MB9AF132MPMC1	
MB9AF131NPMC	Plastic • LQFP(0.5mm pitch), 100-pin (FPT-100P-M23)
MB9AF132NPMC	
MB9AF131NPF	Plastic • QFP(0.65mm pitch), 100-pin (FPT-100P-M06)
MB9AF132NPF	
MB9AF131NBGL	Plastic • PFPGA(0.8mm pitch), 112-pin (BGA-112P-M04)
MB9AF132NBGL	

# MB9A130N Series

## ■ PACKAGE DIMENSIONS

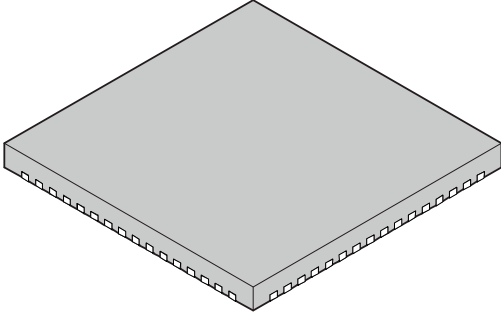
<p>64-pin plastic QFN</p>  <p>(LCC-64P-M24)</p>	Lead pitch	0.50 mm	
	Package width × package length	9.00 mm × 9.00 mm	
	Sealing method	Plastic mold	
	Mounting height	0.90 mm MAX	
	Weight	-	

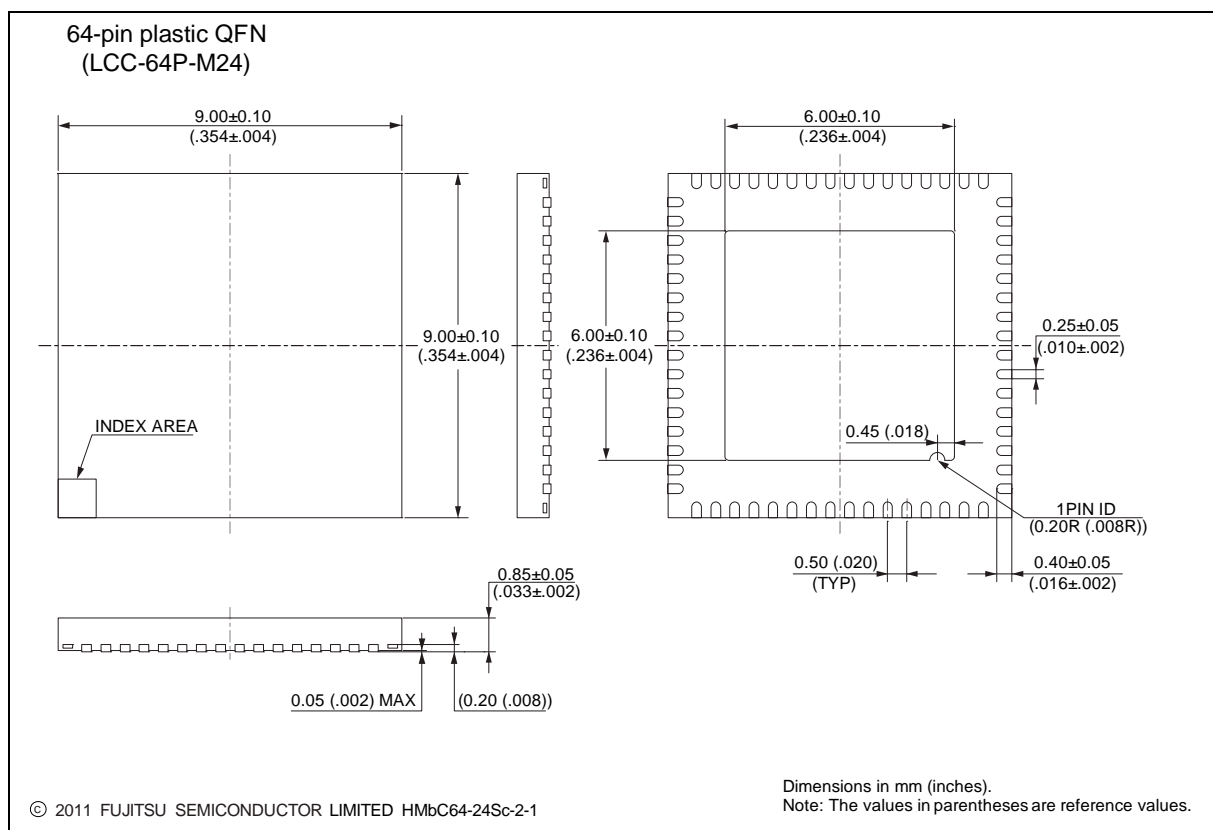

Please check the latest package dimension at the following URL.  
<http://edevice.fujitsu.com/package/en-search/>

# MB9A130N Series

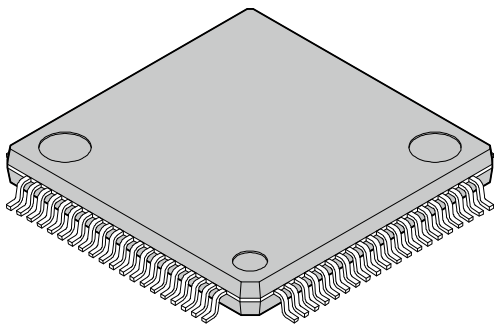
<p>80-pin plastic LQFP</p>  <p>(FPT-80P-M37)</p>	Lead pitch	0.50 mm
	Package width x package length	12.00 mm x 12.00 mm
	Lead shape	Gullwing
	Lead bend direction	Normal bend
	Sealing method	Plastic mold
	Mounting height	1.70 mm MAX
	Weight	0.47 g

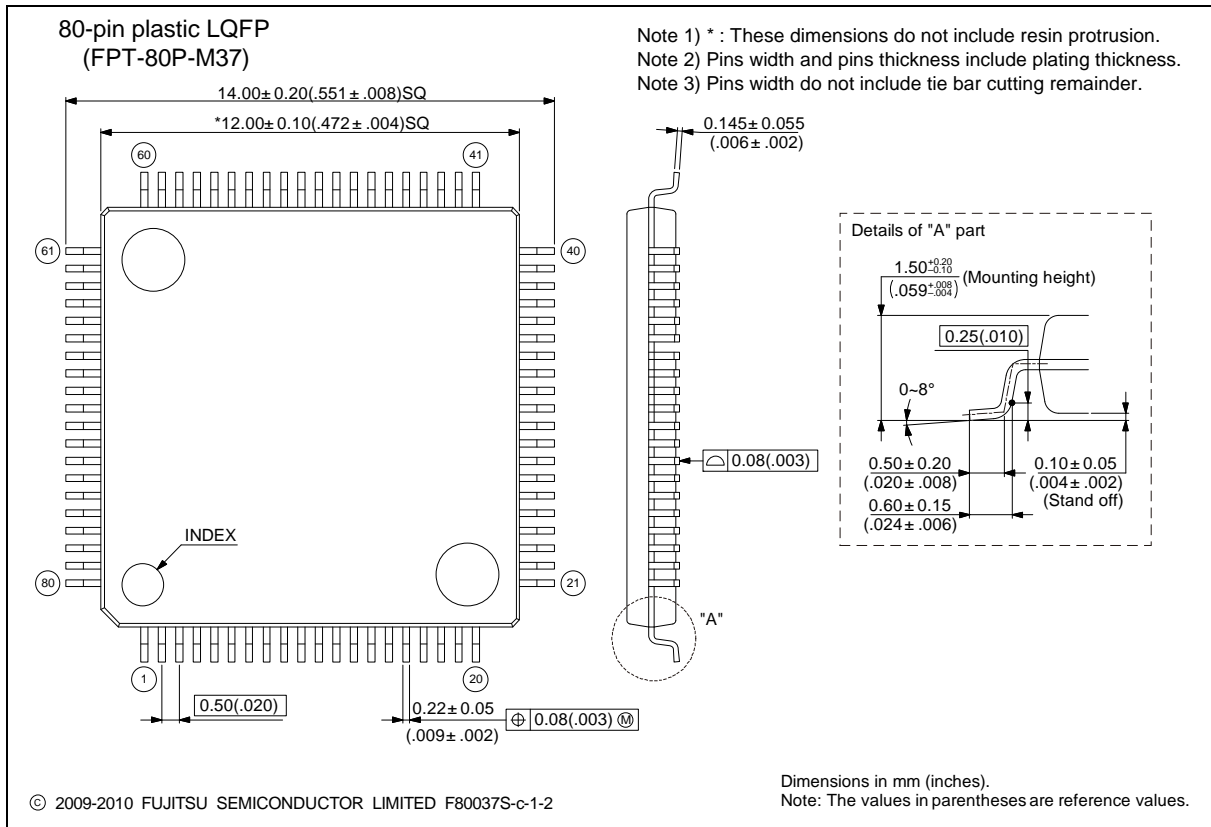

Please check the latest package dimension at the following URL.  
<http://edevice.fujitsu.com/package/en-search/>

# MB9A130N Series

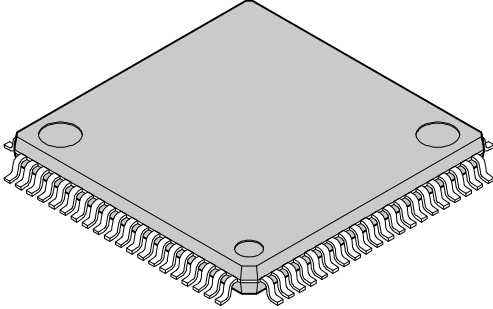
<p style="text-align: center;">80-pin plastic LQFP</p>  <p style="text-align: center;">(FPT-80P-M40)</p>	Lead pitch	0.65 mm
	Package width × package length	14.00 mm × 14.00 mm
	Lead shape	Gullwing
	Sealing method	Plastic mold
	Mounting height	1.60 mm Max.
	Code (Reference)	P-LQFP80-14 × 14-0.65

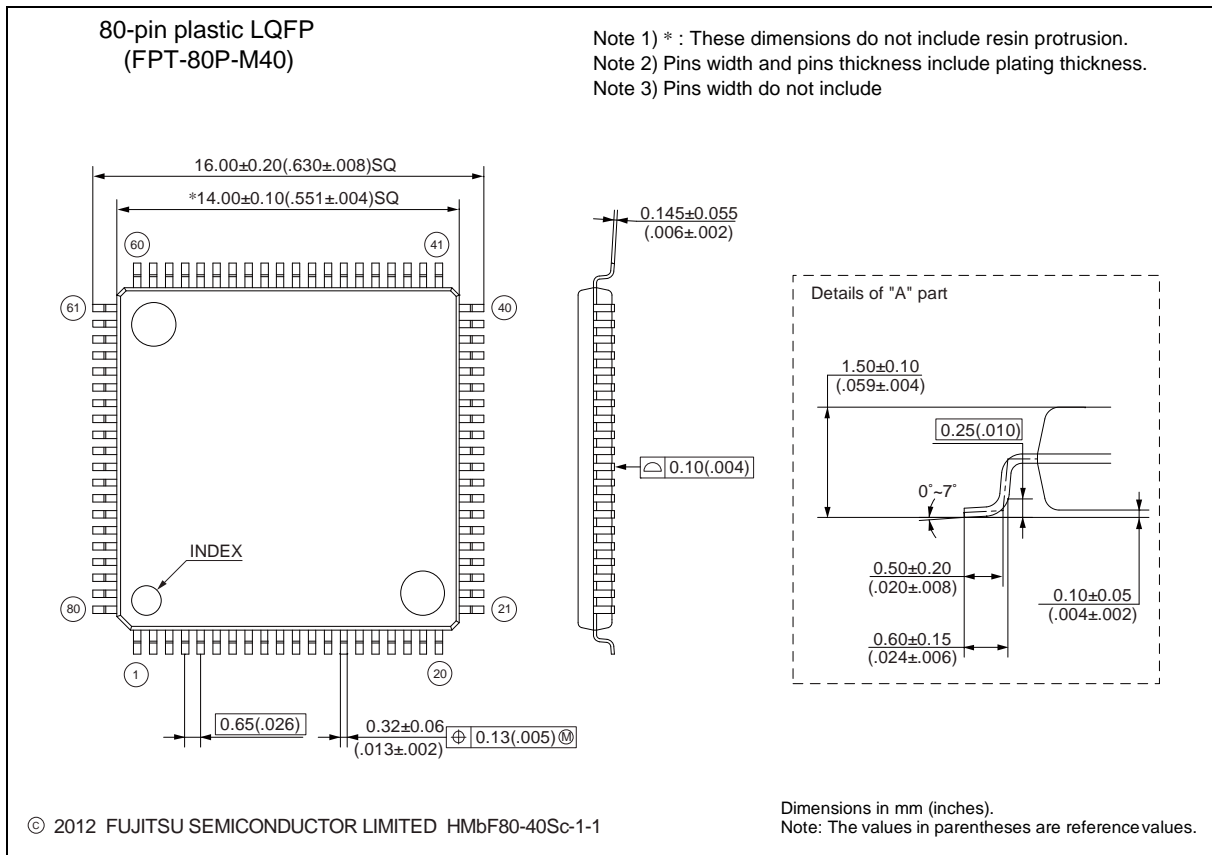

Please check the latest package dimension at the following URL.  
<http://edevice.fujitsu.com/package/en-search/>

# MB9A130N Series

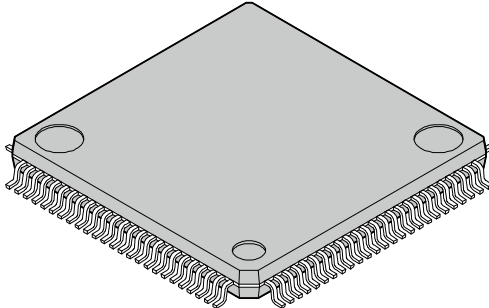
<p>100-pin plastic LQFP</p>  <p>(FPT-100P-M23)</p>	Lead pitch	0.50 mm
	Package width × package length	14.00 mm × 14.00 mm
	Lead shape	Gullwing
	Lead bend direction	Normal bend
	Sealing method	Plastic mold
	Mounting height	1.70 mm MAX
	Weight	0.65 g

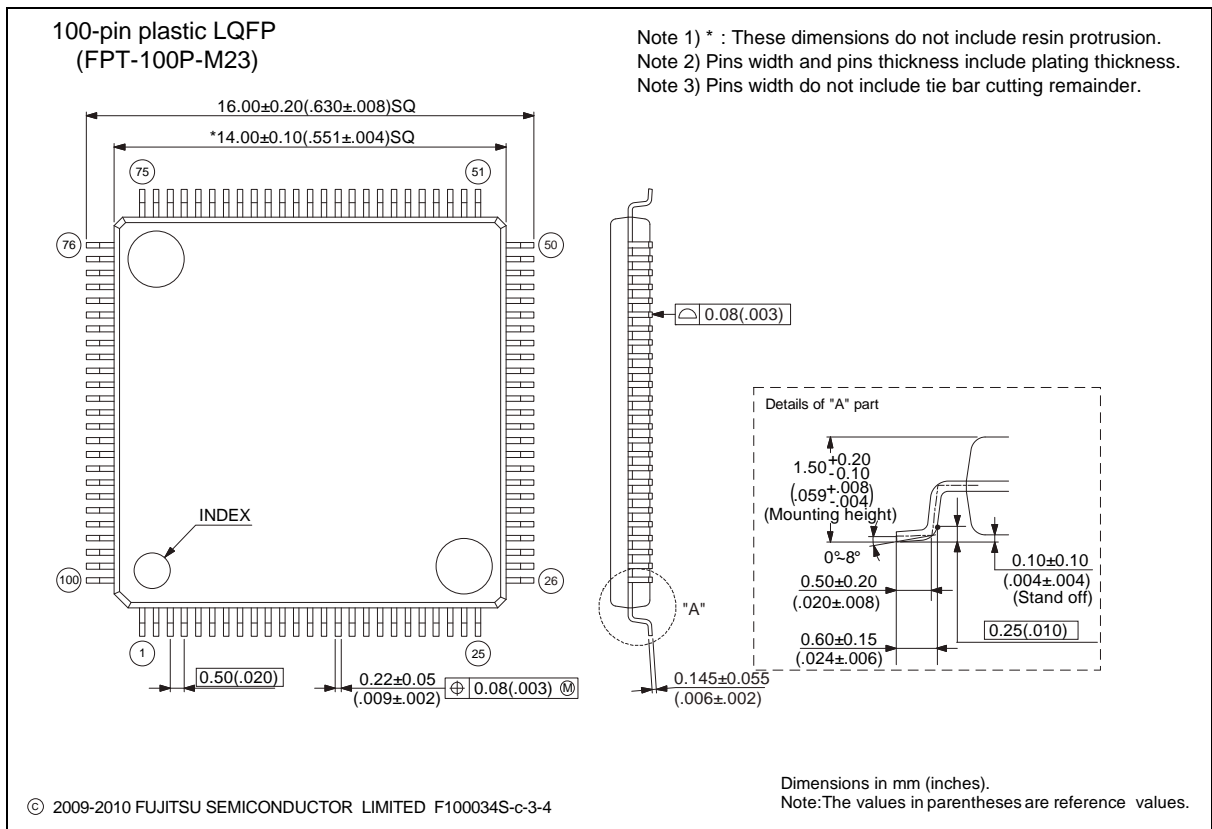

Please check the latest package dimension at the following URL.  
<http://edevice.fujitsu.com/package/en-search/>

# MB9A130N Series

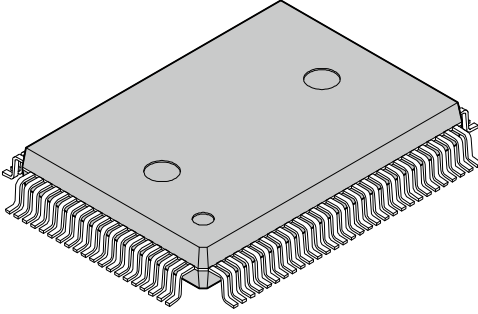
<p>100-pin plastic QFP</p>  <p>(FPT-100P-M06)</p>	Lead pitch	0.65 mm
	Package width x package length	14.00 x 20.00 mm
	Lead shape	Gullwing
	Sealing method	Plastic mold
	Mounting height	3.35 mm MAX
	Code (Reference)	P-QFP100-14x20-0.65

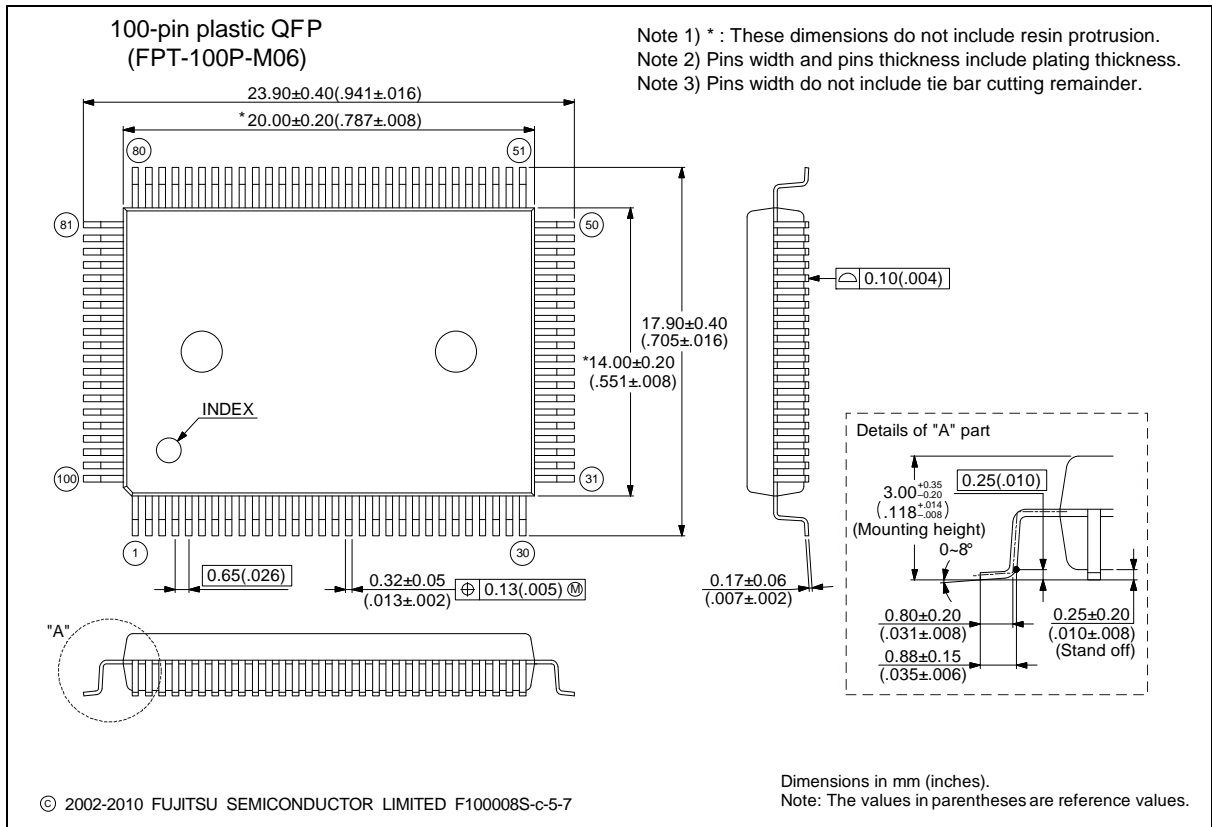

Please check the latest package dimension at the following URL.  
<http://edevice.fujitsu.com/package/en-search/>

# MB9A130N Series

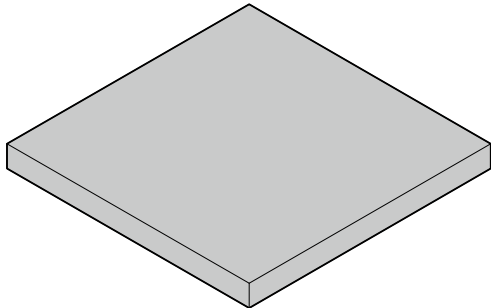
<p>112-ball plastic PFBGA</p>  <p>(BGA-112P-M04)</p>	Ball pitch	0.80 mm
	Package width x package length	10.00 x 10.00 mm
	Lead shape	Soldering ball
	Sealing method	Plastic mold
	Ball size	Φ 0.45 mm
	Mounting height	1.45 mm Max.
	Weight	0.22 g

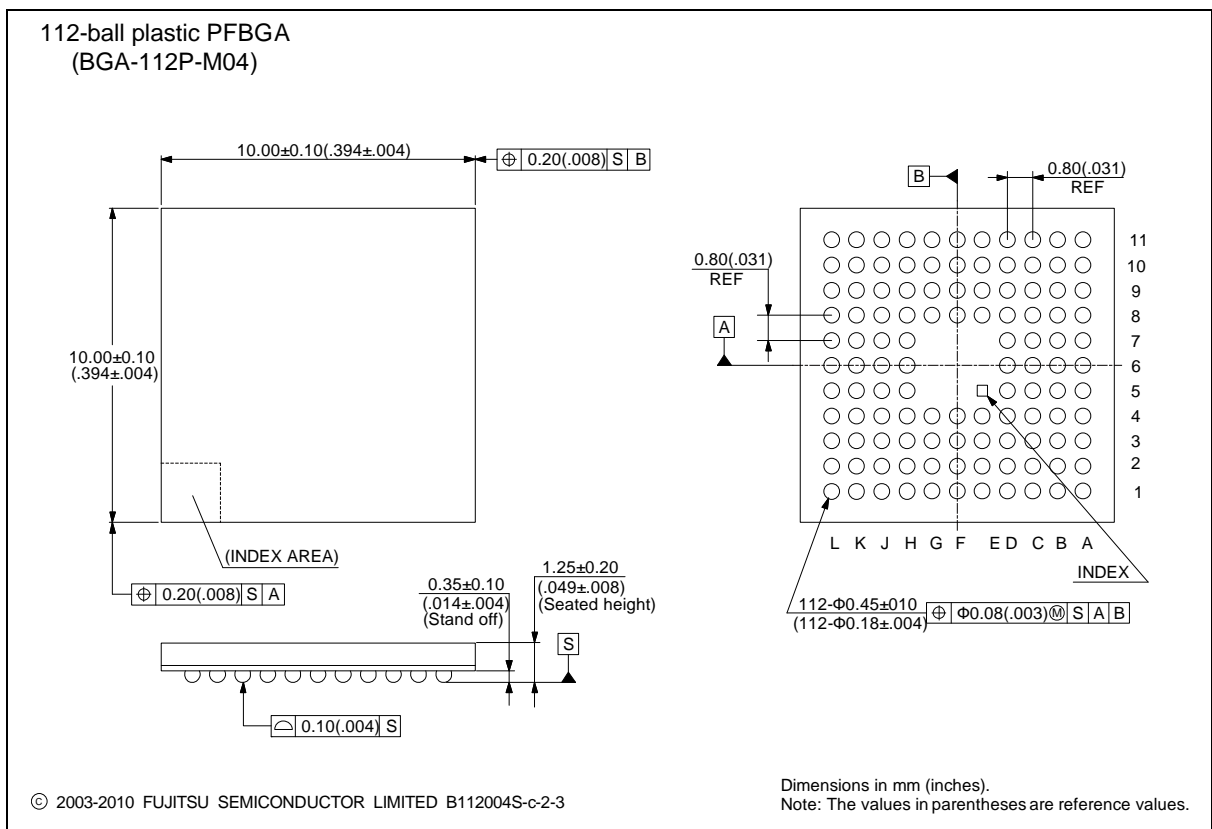

Please check the latest package dimension at the following URL.  
<http://edevice.fujitsu.com/package/en-search/>

# MB9A130N Series

## ■ MAJOR CHANGES IN THIS EDITION

A change on a page is indicated by a vertical line drawn on the left side of that page.

Page	Section	Change Results
15	■LIST OF PIN FUNCTIONS • List of pin numbers	Revised the Pin state type.
22	• List of pin functions	Revised the pin name of "External Interrupt". INIT15_1 → INT15_1
41	■BLOCK DIAGRAM	Revised the description of "Multi-Function Serial IF".
52, 53	■PIN STATUS IN EACH CPU STATE • List of pin status	• Added "S" and "T" type to the Pin status type. • Added the footnote.

**MEMO**

# MB9A130N Series

## FUJITSU SEMICONDUCTOR LIMITED

Nomura Fudosan Shin-yokohama Bldg. 10-23, Shin-yokohama 2-Chome,  
Kohoku-ku Yokohama Kanagawa 222-0033, Japan

Tel: +81-45-415-5858

<http://jp.fujitsu.com/fsl/en/>

*For further information please contact:*

### North and South America

FUJITSU SEMICONDUCTOR AMERICA, INC.  
1250 E. Arques Avenue, M/S 333  
Sunnyvale, CA 94085-5401, U.S.A.  
Tel: +1-408-737-5600 Fax: +1-408-737-5999  
<http://us.fujitsu.com/micro/>

### Asia Pacific

FUJITSU SEMICONDUCTOR ASIA PTE. LTD.  
151 Lorong Chuan,  
#05-08 New Tech Park 556741 Singapore  
Tel : +65-6281-0770 Fax : +65-6281-0220  
<http://sg.fujitsu.com/semiconductor/>

### Europe

FUJITSU SEMICONDUCTOR EUROPE GmbH  
Pittlerstrasse 47, 63225 Langen, Germany  
Tel: +49-6103-690-0 Fax: +49-6103-690-122  
<http://emea.fujitsu.com/semiconductor/>

### FUJITSU SEMICONDUCTOR SHANGHAI CO., LTD.

30F, Kerry Parkside, 1155 Fang Dian Road,  
Pudong District, Shanghai 201204, China  
Tel : +86-21-6146-3688 Fax : +86-21-6146-3660  
<http://cn.fujitsu.com/fss/>

### Korea

FUJITSU SEMICONDUCTOR KOREA LTD.  
902 Kosmo Tower Building, 1002 Daechi-Dong,  
Gangnam-Gu, Seoul 135-280, Republic of Korea  
Tel: +82-2-3484-7100 Fax: +82-2-3484-7111  
<http://kr.fujitsu.com/fsk/>

### FUJITSU SEMICONDUCTOR PACIFIC ASIA LTD.

2/F, Green 18 Building, Hong Kong Science Park,  
Shatin, N.T., Hong Kong  
Tel : +852-2736-3232 Fax : +852-2314-4207  
<http://cn.fujitsu.com/fsp/>

### All Rights Reserved.

FUJITSU SEMICONDUCTOR LIMITED, its subsidiaries and affiliates (collectively, "FUJITSU SEMICONDUCTOR") reserves the right to make changes to the information contained in this document without notice. Please contact your FUJITSU SEMICONDUCTOR sales representatives before order of FUJITSU SEMICONDUCTOR device.

Information contained in this document, such as descriptions of function and application circuit examples is presented solely for reference to examples of operations and uses of FUJITSU SEMICONDUCTOR device. FUJITSU SEMICONDUCTOR disclaims any and all warranties of any kind, whether express or implied, related to such information, including, without limitation, quality, accuracy, performance, proper operation of the device or non-infringement. If you develop equipment or product incorporating the FUJITSU SEMICONDUCTOR device based on such information, you must assume any responsibility or liability arising out of or in connection with such information or any use thereof. FUJITSU SEMICONDUCTOR assumes no responsibility or liability for any damages whatsoever arising out of or in connection with such information or any use thereof.

Nothing contained in this document shall be construed as granting or conferring any right under any patents, copyrights, or any other intellectual property rights of FUJITSU SEMICONDUCTOR or any third party by license or otherwise, express or implied. FUJITSU SEMICONDUCTOR assumes no responsibility or liability for any infringement of any intellectual property rights or other rights of third parties resulting from or in connection with the information contained herein or use thereof.

The products described in this document are designed, developed and manufactured as contemplated for general use including without limitation, ordinary industrial use, general office use, personal use, and household use, but are not designed, developed and manufactured as contemplated (1) for use accompanying fatal risks or dangers that, unless extremely high levels of safety is secured, could lead directly to death, personal injury, severe physical damage or other loss (including, without limitation, use in nuclear facility, aircraft flight control system, air traffic control system, mass transport control system, medical life support system and military application), or (2) for use requiring extremely high level of reliability (including, without limitation, submersible repeater and artificial satellite). FUJITSU SEMICONDUCTOR shall not be liable for you and/or any third party for any claims or damages arising out of or in connection with above-mentioned uses of the products.

Any semiconductor devices fail or malfunction with some probability. You are responsible for providing adequate designs and safeguards against injury, damage or loss from such failures or malfunctions, by incorporating safety design measures into your facility, equipments and products such as redundancy, fire protection, and prevention of overcurrent levels and other abnormal operating conditions.

The products and technical information described in this document are subject to the Foreign Exchange and Foreign Trade Control Law of Japan, and may be subject to export or import laws or regulations in U.S. or other countries. You are responsible for ensuring compliance with such laws and regulations relating to export or re-export of the products and technical information described herein.

All company names, brand names and trademarks herein are property of their respective owners.