

32-bit ARM™ Cortex™-M3 based Microcontroller

FM3 MB9B410T Series

MB9BF416S/T, MB9BF417S/T, MB9BF418S/T

■ DESCRIPTION

The MB9B410T Series are highly integrated 32-bit microcontrollers dedicated for embedded controllers with high-performance and competitive cost.

These series are based on the ARM Cortex-M3 Processor with on-chip Flash memory and SRAM, and has peripheral functions such as Motor Control Timers, ADCs and Communication Interfaces (CAN, UART, CSIO, I²C, LIN).

The products which are described in this data sheet are placed into TYPE2 product categories in "FM3 Family PERIPHERAL MANUAL".

Note: ARM and Cortex are the trademarks of ARM Limited in the EU and other countries.



MB9B410T Series

■ FEATURES

● 32-bit ARM Cortex-M3 Core

- Processor version: r2p1
- Up to 144MHz Frequency Operation
- Memory Protection Unit (MPU):improves the reliability of an embedded system
- Integrated Nested Vectored Interrupt Controller (NVIC): 1 NMI (non-maskable interrupt) and 48 peripheral interrupts and 16 priority levels
- 24-bit System timer (Sys Tick): System timer for OS task management

● On-chip Memories

[Flash memory]

- Up to 1 Mbyte
- Built-in Flash Accelerator System with 16Kbyte trace buffer memory
The read access to Flash memory can be achieved without wait cycle up to operation frequency of 72MHz. Even at the operation frequency more than 72MHz, an equivalent access to Flash memory can be obtained by Flash Accelerator System.
- Security function for code protection

[SRAM]

This Series contain a total of up to 128Kbyte on-chip SRAM memories. This is composed of two independent SRAM (SRAM0,SRAM1) . SRAM0 is connected to I-code bus or D-code bus of Cortex-M3 core. SRAM1 is connected to System bus.

- SRAM0: Up to 64 Kbyte.
- SRAM1: Up to 64 Kbyte.

● External Bus Interface

- Supports SRAM, NOR and NAND Flash device
- Up to 8 chip selects
- 8/16-bit Data width
- Up to 25-bit Address bit
- Supports Address/Data multiplex
- Supports external RDY input

● CAN Interface (Max. 2channels)

- Compatible with CAN Specification 2.0A/B
- Maximum transfer rate: 1 Mbps
- Built-in 32 message buffer

● Multi-function Serial Interface (Max 8channels)

- 4 channels with 16steps×9-bit FIFO (ch.4 to ch.7), 4 channels without FIFO (ch.0 to ch.3)
- Operation mode is selectable from the followings for each channel.
 - UART
 - CSIO
 - LIN
 - I²C

[UART]

- Full-duplex double buffer
- Selection with or without parity supported
- Built-in dedicated baud rate generator
- External clock available as a serial clock
- Hardware Flow control : Automatically control the transmission by CTS/RTS (only ch.4)
- Various error detect functions available (parity errors, framing errors, and overrun errors)

[CSIO]

- Full-duplex double buffer
- Built-in dedicated baud rate generator
- Overrun error detect function available

[LIN]

- LIN protocol Rev.2.1 supported
- Full-duplex double buffer
- Master/Slave mode supported
- LIN break field generate (can be changed 13-16-bit length)
- LIN break delimiter generate (can be changed 1-4-bit length)
- Various error detect functions available (parity errors, framing errors, and overrun errors)

[I²C]

Standard mode (Max 100kbps) / High-speed mode (Max 400kbps) supported

● DMA Controller (8channels)

DMA Controller has an independent bus for CPU, so CPU and DMA Controller can process simultaneously.

- 8 independently configured and operated channels
- Transfer can be started by software or request from the built-in peripherals
- Transfer address area: 32bit(4Gbyte)
- Transfer mode: Block transfer/Burst transfer/Demand transfer
- Transfer data type: byte/half-word/word
- Transfer block count: 1 to 16
- Number of transfers: 1 to 65536

● A/D Converter (Max 32channels)

[12-bit A/D Converter]

- Successive Approximation Register type
- Built-in 3unit
- Conversion time: 1.0 μ s@5V
- Priority conversion available (priority at 2levels)
- Scanning conversion mode
- Built-in FIFO for conversion data storage (for SCAN conversion: 16steps, for Priority conversion: 4steps)

● Base Timer (Max 16channels)

Operation mode is selectable from the followings for each channel.

- 16-bit PWM timer
- 16-bit PPG timer
- 16/32-bit reload timer
- 16/32-bit PWC timer

● General Purpose I/O Port

This series can use its pins as I/O ports when they are not used for external bus or peripherals. Moreover, the port relocate function is built in. It can set which I/O port the peripheral function can be allocated.

- Capable of pull-up control per pin
- Capable of reading pin level directly
- Built-in the port relocate function
- Up 154 fast I/O Ports@176pin Package
- Some pin is 5V tolerant I/O.

MB9B410T Series

- Multi-function Timer (Max 3units)

The Multi-function timer is composed of the following blocks.

- 16-bit free-run timer × 3ch/unit
- Input capture × 4ch/unit
- Output compare × 6ch/unit
- A/D activating compare × 3ch/unit
- Waveform generator × 3ch/unit
- 16-bit PPG timer × 3ch/unit

The following function can be used to achieve the motor control.

- PWM signal output function
- DC chopper waveform output function
- Dead time function
- Input capture function
- A/D convertor activate function
- DTIF (Motor emergency stop) interrupt function

- Quadrature Position/Revolution Counter (QPRC) (Max 3channels)

The Quadrature Position/Revolution Counter (QPRC) is used to measure the position of the position encoder. Moreover, it is possible to use up/down counter.

- The detection edge of the three external event input pins AIN, BIN and ZIN is configurable.
- 16-bit position counter
- 16-bit revolution counter
- Two 16-bit compare registers

- Dual Timer (32/16bit Down Counter)

The Dual Timer consists of two programmable 32/16-bit down counters. Operation mode is selectable from the followings for each channel.

- Free-running
- Periodic (=Reload)
- One-shot

- Watch Counter

The Watch counter is used for wake up from power saving mode.

Interval timer: up to 64s(Max)@ Sub Clock : 32.768kHz

- External Interrupt Controller Unit

- Up to 32 external interrupt input pin
- Include one non-maskable interrupt(NMI)

- Watch dog Timer (2channels)

A watchdog timer can generate interrupts or a reset when a time-out value is reached.

This series consists of two different watchdogs, a "Hardware" watchdog and a "Software" watchdog.

"Hardware" watchdog timer is clocked by low speed internal CR oscillator. Therefore, "Hardware" watchdog is active in any power saving mode except STOP.

- **CRC (Cyclic Redundancy Check) Accelerator**

The CRC accelerator helps a verify data transmission or storage integrity.

CCITT CRC16 and IEEE-802.3 CRC32 are supported.

- CCITT CRC16 Generator Polynomial: 0x1021
- IEEE-802.3 CRC32 Generator Polynomial: 0x04C11DB7

- **Clock and Reset**

[Clocks]

Five clock sources (2 external oscillators, 2 internal CR oscillators, and Main PLL) that are dynamically selectable.

- Main Clock : 4MHz to 48MHz
- Sub Clock : 32.768kHz
- High-speed internal CR Clock : 4MHz
- Low-speed internal CR Clock : 100kHz
- Main PLL Clock

[Resets]

- Reset requests from INITX pin
- Power on reset
- Software reset
- Watchdog timers reset
- Low voltage detector reset
- Clock supervisor reset

- **Clock Super Visor (CSV)**

Clocks generated by internal CR oscillators are used to supervise abnormality of the external clocks.

- External OSC clock failure (clock stop) is detected, reset is asserted.
- External OSC frequency anomaly is detected, interrupt or reset is asserted.

- **Low Voltage Detector (LVD)**

This Series include 2-stage monitoring of voltage on the VCC pins. When the voltage falls below the voltage has been set, Low Voltage Detector generates an interrupt or reset.

- LVD1: error reporting via interrupt
- LVD2: auto-reset operation

- **Low Power Mode**

Three power saving modes supported.

- SLEEP
- TIMER
- STOP

- **Debug**

- Serial Wire JTAG Debug Port (SWJ-DP)
- Embedded Trace Macrocells (ETM) provide comprehensive debug and trace facilities.

- **Power Supply**

Wide range voltage VCC = 2.7V to 5.5V

MB9B410T Series

■ PRODUCT LINEUP

● Memory size

Product name	MB9BF416S/T	MB9BF417S/T	MB9BF418S/T
On-chip Flash	512Kbyte	768Kbyte	1Mbyte
On-chip RAM	64Kbyte	96Kbyte	128Kbyte

● Function

Product name		MB9BF416S MB9BF417S MB9BF418S	MB9BF416T MB9BF417T MB9BF418T
Pin count		144	176/192
CPU		Cortex-M3	
Freq.		144MHz	
Power supply voltage range		VCC:2.7V to 5.5V	
CAN Interface		2ch. (Max)	
DMAC		8ch.	
External Bus Interface		Addr:19-bit (Max) R/Wdata:8/16-bit (Max) CS: 8 (Max) Support: SRAM, NOR & NAND Flash	Addr:25-bit (Max) R/Wdata:8/16-bit (Max) CS:8 (Max) Support: SRAM, NOR & NAND Flash
Multi-function Serial Interface (UART/CSIO/LIN/I ² C)		8ch. (Max) ch.4 to ch.7: FIFO (16steps × 9-bit) ch.0 to ch.3: No FIFO	
Base Timer (PWC/ Reload timer/PWM/PPG)		16ch.(Max)	
MF-Timer	A/D activation compare	3ch.	3 units (Max)
	Input capture	4ch.	
	Free-run timer	3ch.	
	Output compare	6ch.	
	Waveform generator	3ch.	
	PPG	3ch.	
QPRC		3ch. (Max)	
Dual Timer		1 unit	
Watch Counter		1 unit	
CRC Accelerator		Yes	
Watchdog timer		1ch.(SW) + 1ch.(HW)	
External Interrupts		32pins (Max)+ NMI × 1	
I/O ports		122pins (Max)	154pins (Max)
12-bit A/D converter		24ch. (3 units)	32ch. (3 units)
CSV (Clock Super Visor)		Yes	
LVD (Low Voltage Detector)		2ch.	
Built-in CR	High-speed	4MHz (± 2%)	
	Low-speed	100kHz (Typ)	
Debug Function		SWJ-DP/ETM	

Note: All signals of the peripheral function in each product cannot be allocated by limiting the pins of package.

It is necessary to use the port relocate function of the General I/O port according to your function use.

MB9B410T Series

■ PACKAGES

Package \ Product name	MB9BF416S MB9BF417S MB9BF418S	MB9BF416T MB9BF417T MB9BF418T
LQFP: FPT-144P-M08 (0.5mm pitch)	○	-
LQFP: FPT-176P-M07 (0.5mm pitch)	-	○
BGA: BGA-192P-M06 (0.8mm pitch)	-	○

○ : Supported

Note : See "■PACKAGE DIMENSIONS" for detailed information on each package.

MB9B410T Series

■ PIN ASSIGNMENT

• FPT-176P-M07

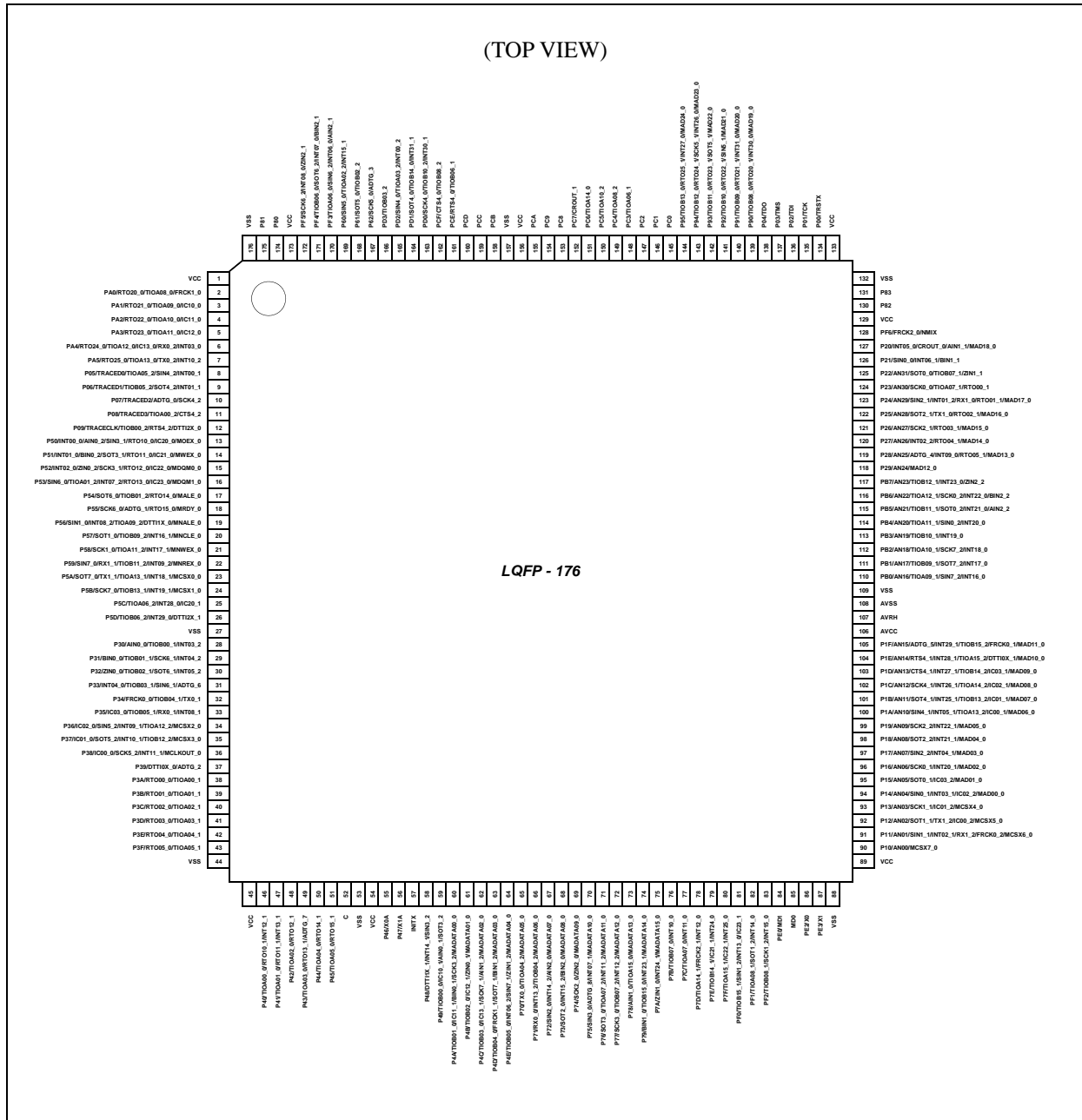

<Note>

The number after the underscore ("_") in pin names such as XXX_1 and XXX_2 indicates the relocated port number. For these pins, there are multiple pins that provide the same function for the same channel. Use the extended port function register (EPFR) to select the pin.

TIOA09_0, TIOA09_1, and TIOA09_2 cannot be used as the external startup trigger input (TGIN signal) at I/O mode 1 (timer full mode) of the Base Timer. See "●Base Timer" in "■HANDLING DEVICES" for details.

• FPT-144P-M08

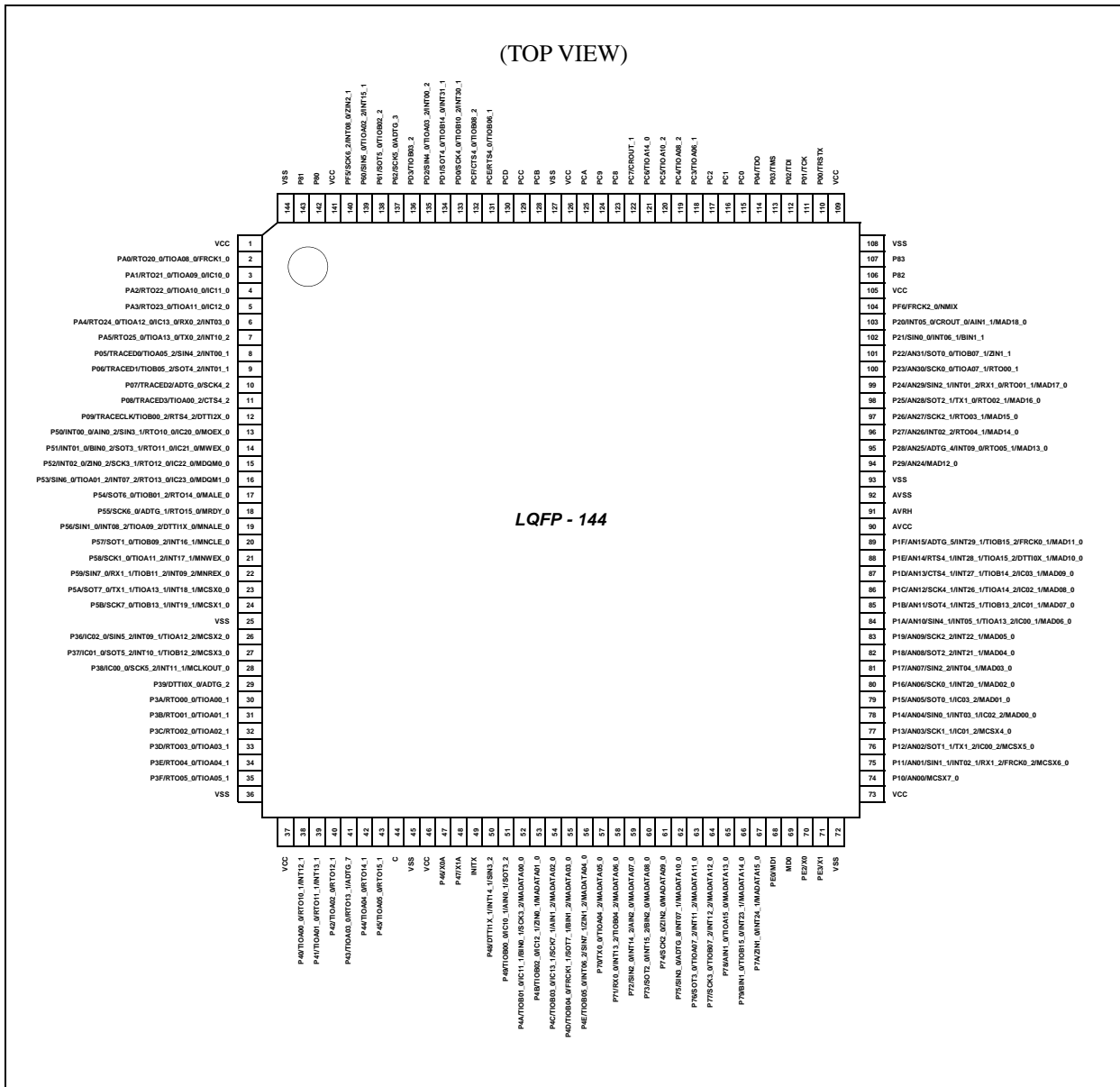

<Note>

The number after the underscore ("_") in pin names such as XXX_1 and XXX_2 indicates the relocated port number. For these pins, there are multiple pins that provide the same function for the same channel. Use the extended port function register (EPFR) to select the pin.

TIOA09_0 and TIOA09_2 cannot be used as the external startup trigger input (TGIN signal) at I/O mode 1 (timer full mode) of the Base Timer. See "●Base Timer" in "■HANDLING DEVICES" for details.

MB9B410T Series

• BGA-192P-M06

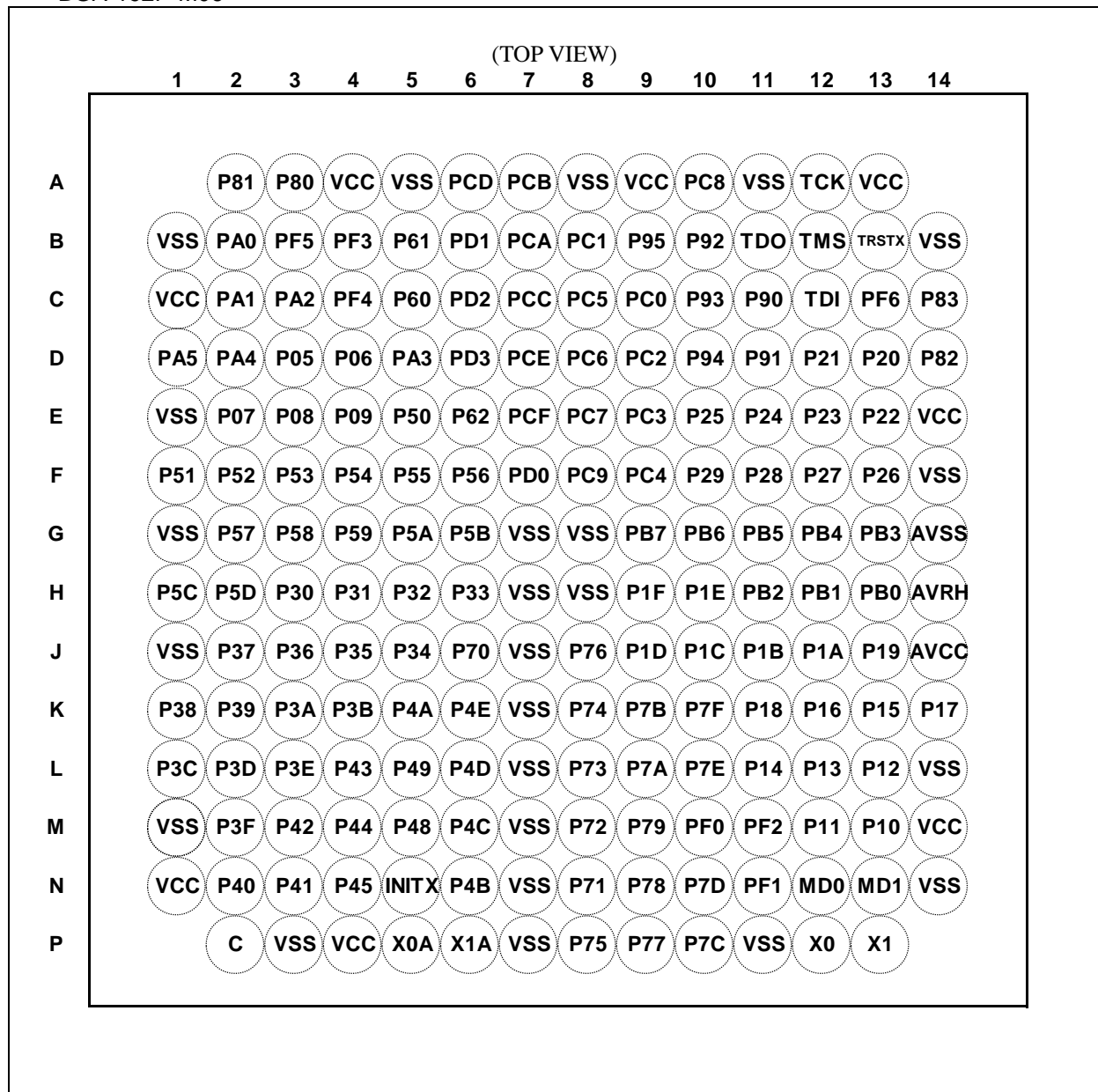

<Note>

The number after the underscore ("_") in pin names such as XXX_1 and XXX_2 indicates the relocated port number. For these pins, there are multiple pins that provide the same function for the same channel. Use the extended port function register (EPFR) to select the pin.

TIOA09_0, TIOA09_1, and TIOA09_2 cannot be used as the external startup trigger input (TGIN signal) at I/O mode 1 (timer full mode) of the Base Timer. See "●Base Timer" in "■HANDLING DEVICES" for details.

■ LIST OF PIN FUNCTIONS

The number after the underscore ("_") in pin names such as XXX_1 and XXX_2 indicates the relocated port number. For these pins, there are multiple pins that provide the same function for the same channel. Use the extended port function register (EPFR) to select the pin.

Pin No			Pin Name	I/O circuit type	Pin state type
LQFP-176	LQFP-144	BGA-192			
1	1	C1	VCC	-	
2	2	B2	PA0	G	I
			RTO20_0		
			TIOA08_0		
			FRCK1_0		
3	3	C2	PA1	G	I
			RTO21_0		
			TIOA09_0		
			IC10_0		
4	4	C3	PA2	G	I
			RTO22_0		
			TIOA10_0		
			IC11_0		
5	5	D5	PA3	G	I
			RTO23_0		
			TIOA11_0		
			IC12_0		
6	6	D2	PA4	G	H
			RTO24_0		
			TIOA12_0		
			RX0_2		
			IC13_0		
			INT03_0		
7	7	D1	PA5	G	H
			RTO25_0		
			TX0_2		
			TIOA13_0		
			INT10_2		
8	8	D3	P05	E	F
			TRACED0		
			TIOA05_2		
			SIN4_2		
			INT00_1		
9	9	D4	P06	E	F
			TRACED1		
			TIOB05_2		
			SOT4_2		
			INT01_1		

MB9B410T Series

Pin No			Pin Name	I/O circuit type	Pin state type
LQFP-176	LQFP-144	BGA-192			
10	10	E2	P07	E	G
			TRACED2		
			ADTG_0		
			SCK4_2		
11	11	E3	P08	E	G
			TRACED3		
			TIOA00_2		
			CTS4_2		
12	12	E4	P09	E	G
			TRACECLK		
			TIOB00_2		
			RTS4_2		
			DTI2X_0		
13	13	E5	P50	E	H
			INT00_0		
			AIN0_2		
			SIN3_1		
			RTO10_0		
			IC20_0		
			MOEX_0		
14	14	F1	P51	E	H
			INT01_0		
			BIN0_2		
			SOT3_1		
			RTO11_0		
			IC21_0		
			MWEX_0		
15	15	F2	P52	E	H
			INT02_0		
			ZIN0_2		
			SCK3_1		
			RTO12_0		
			IC22_0		
			MDQM0_0		

MB9B410T Series

Pin No			Pin Name	I/O circuit type	Pin state type
LQFP-176	LQFP-144	BGA-192			
16	16	F3	P53	E	H
			SIN6_0		
			TIOA01_2		
			INT07_2		
			RTO13_0		
			IC23_0		
			MDQM1_0		
17	17	F4	P54	E	I
			SOT6_0		
			TIOB01_2		
			RTO14_0		
			MALE_0		
18	18	F5	P55	E	I
			SCK6_0		
			ADTG_1		
			RTO15_0		
			MRDY_0		
19	19	F6	P56	E	H
			SIN1_0		
			INT08_2		
			TIOA09_2		
			DTT11X_0		
			MNALE_0		
20	20	G2	P57	E	H
			SOT1_0		
			TIOB09_2		
			INT16_1		
			MNCLE_0		
21	21	G3	P58	E	H
			SCK1_0		
			TIOA11_2		
			INT17_1		
			MNWEX_0		
22	22	G4	P59	E	H
			SIN7_0		
			RX1_1		
			TIOB11_2		
			INT09_2		
			MNREX_0		

MB9B410T Series

Pin No			Pin name	I/O circuit type	Pin state type
LQFP-176	LQFP-144	BGA-192			
23	23	G5	P5A	E	H
			SOT7_0		
			TX1_1		
			TIOA13_1		
			INT18_1		
			MCSX0_0		
24	24	G6	P5B	E	H
			SCK7_0		
			TIOB13_1		
			INT19_1		
			MCSX1_0		
25	-	H1	P5C	E	H
			TIOA06_2		
			INT28_0		
			IC20_1		
26	-	H2	P5D	E	H
			TIOB06_2		
			INT29_0		
			DTTI2X_1		
27	25	J1	VSS	-	
28	-	H3	P30	E	H
			AIN0_0		
			TIOB00_1		
			INT03_2		
29	-	H4	P31	E	H
			BIN0_0		
			TIOB01_1		
			SCK6_1		
			INT04_2		
30	-	H5	P32	E	H
			ZIN0_0		
			TIOB02_1		
			SOT6_1		
			INT05_2		
31	-	H6	P33	E	H
			INT04_0		
			TIOB03_1		
			SIN6_1		
			ADTG_6		

MB9B410T Series

Pin No			Pin name	I/O circuit type	Pin state type
LQFP-176	LQFP-144	BGA-192			
32	-	J5	P34	E	I
			FRCK0_0		
			TX0_1		
			TIOB04_1		
33	-	J4	P35	E	H
			IC03_0		
			RX0_1		
			TIOB05_1		
			INT08_1		
34	26	J3	P36	E	H
			IC02_0		
			SIN5_2		
			INT09_1		
			TIOA12_2		
			MCSX2_0		
35	27	J2	P37	E	H
			IC01_0		
			SOT5_2		
			INT10_1		
			TIOB12_2		
			MCSX3_0		
36	28	K1	P38	E	H
			IC00_0		
			SCK5_2		
			INT11_1		
			MCLKOUT_0		
37	29	K2	P39	E	I
			DTTIOX_0		
			ADTG_2		
38	30	K3	P3A	G	I
			RTO00_0		
			TIOA00_1		
39	31	K4	P3B	G	I
			RTO01_0		
			TIOA01_1		
40	32	L1	P3C	G	I
			RTO02_0		
			TIOA02_1		

MB9B410T Series

Pin No			Pin name	I/O circuit type	Pin state type
LQFP-176	LQFP-144	BGA-192			
41	33	L2	P3D	G	I
			RTO03_0		
			TIOA03_1		
42	34	L3	P3E	G	I
			RTO04_0		
			TIOA04_1		
43	35	M2	P3F	G	I
			RTO05_0		
			TIOA05_1		
44	36	M1	VSS	-	
45	37	N1	VCC	-	
46	38	N2	P40	G	H
			TIOA00_0		
			RTO10_1		
			INT12_1		
47	39	N3	P41	G	H
			TIOA01_0		
			RTO11_1		
			INT13_1		
48	40	M3	P42	G	I
			TIOA02_0		
			RTO12_1		
49	41	L4	P43	G	I
			TIOA03_0		
			RTO13_1		
			ADTG_7		
50	42	M4	P44	G	I
			TIOA04_0		
			RTO14_1		
51	43	N4	P45	G	I
			TIOA05_0		
			RTO15_1		
52	44	P2	C	-	
53	45	P3	VSS	-	
54	46	P4	VCC	-	
55	47	P5	P46	D	M
			X0A		
56	48	P6	P47	D	M
			X1A		
57	49	N5	INITX	B	C
58	50	M5	P48	E	H
			DTT1X_1		
			INT14_1		
			SIN3_2		

MB9B410T Series

Pin No			Pin name	I/O circuit type	Pin state type
LQFP-176	LQFP-144	BGA-192			
59	51	L5	P49	E	I
			TIOB00_0		
			IC10_1		
			AIN0_1		
			SOT3_2		
60	52	K5	P4A	E	I
			TIOB01_0		
			IC11_1		
			BIN0_1		
			SCK3_2		
MADATAA00_0					
61	53	N6	P4B	E	I
			TIOB02_0		
			IC12_1		
			ZIN0_1		
			MADATAA01_0		
62	54	M6	P4C	E	I
			TIOB03_0		
			IC13_1		
			SCK7_1		
			AIN1_2		
MADATAA02_0					
63	55	L6	P4D	E	I
			TIOB04_0		
			FRCK1_1		
			SOT7_1		
			BIN1_2		
MADATAA03_0					
64	56	K6	P4E	E	H
			TIOB05_0		
			INT06_2		
			SIN7_1		
			ZIN1_2		
MADATAA04_0					
65	57	J6	P70	E	I
			TIOA04_2		
			TX0_0		
			MADATAA05_0		
66	58	N8	P71	E	H
			INT13_2		
			TIOB04_2		
			RX0_0		
			MADATAA06_0		

MB9B410T Series

Pin No			Pin name	I/O circuit type	Pin state type
LQFP-176	LQFP-144	BGA-192			
67	59	M8	P72	E	H
			SIN2_0		
			INT14_2		
			AIN2_0		
			MADATA07_0		
68	60	L8	P73	E	H
			SOT2_0		
			INT15_2		
			BIN2_0		
			MADATA08_0		
69	61	K8	P74	E	I
			SCK2_0		
			ZIN2_0		
			MADATA09_0		
70	62	P8	P75	E	H
			SIN3_0		
			ADTG_8		
			INT07_1		
			MADATA10_0		
71	63	J8	P76	E	H
			SOT3_0		
			TIOA07_2		
			INT11_2		
			MADATA11_0		
72	64	P9	P77	E	H
			SCK3_0		
			TIOB07_2		
			INT12_2		
			MADATA12_0		
73	65	N9	P78	E	I
			AIN1_0		
			TIOA15_0		
			MADATA13_0		
74	66	M9	P79	E	H
			BIN1_0		
			TIOB15_0		
			INT23_1		
			MADATA14_0		
-	-	E1	VSS	-	-
-	-	G1	VSS	-	-

MB9B410T Series

Pin No			Pin name	I/O circuit type	Pin state type
LQFP-176	LQFP-144	BGA-192			
75	67	L9	P7A	E	H
			ZIN1_0		
			INT24_1		
			MADATA15_0		
76	-	K9	P7B	E	H
			TIOB07_0		
			INT10_0		
77	-	P10	P7C	E	H
			TIOA07_0		
			INT11_0		
78	-	N10	P7D	E	H
			TIOA14_1		
			FRCK2_1		
			INT12_0		
79	-	L10	P7E	E	H
			TIOB14_1		
			IC21_1		
			INT24_0		
80	-	K10	P7F	E	H
			TIOA15_1		
			IC22_1		
			INT25_0		
81	-	M10	PF0	I*	H
			TIOB15_1		
			SIN1_2		
			INT13_0		
82	-	N11	PF1	I*	H
			TIOA08_1		
			SOT1_2		
			INT14_0		
83	-	M11	PF2	I*	H
			TIOB08_1		
			SCK1_2		
			INT15_0		
84	68	N13	PE0	C	P
85	69	N12	MD1	J	D
86	70	P12	PE2	A	A
			X0		
87	71	P13	PE3	A	B
			X1		
88	72	N14	VSS	-	-
89	73	M14	VCC	-	-
-	-	L7	VSS	-	-
-	-	K7	VSS	-	-

MB9B410T Series

Pin No			Pin name	I/O circuit type	Pin state type
LQFP-176	LQFP-144	BGA-192			
90	74	M13	P10	F	K
			AN00		
			MCSX7_0		
91	75	M12	P11	F	L
			AN01		
			SIN1_1		
			RX1_2		
			INT02_1		
			FRCK0_2		
			MCSX6_0		
92	76	L13	P12	F	K
			AN02		
			SOT1_1		
			TX1_2		
			IC00_2		
			MCSX5_0		
93	77	L12	P13	F	K
			AN03		
			SCK1_1		
			IC01_2		
			MCSX4_0		
94	78	L11	P14	F	L
			AN04		
			SIN0_1		
			INT03_1		
			IC02_2		
			MAD00_0		
95	79	K13	P15	F	K
			AN05		
			SOT0_1		
			IC03_2		
			MAD01_0		
96	80	K12	P16	F	L
			AN06		
			SCK0_1		
			INT20_1		
			MAD02_0		
97	81	K14	P17	F	L
			AN07		
			SIN2_2		
			INT04_1		
			MAD03_0		
-	-	P7	VSS	-	-
-	-	P11	VSS	-	-
-	-	L14	VSS	-	-

MB9B410T Series

Pin No			Pin name	I/O circuit type	Pin state type
LQFP-176	LQFP-144	BGA-192			
98	82	K11	P18	F	L
			AN08		
			SOT2_2		
			INT21_1		
			MAD04_0		
99	83	J13	P19	F	L
			AN09		
			SCK2_2		
			INT22_1		
			MAD05_0		
100	84	J12	P1A	F	L
			AN10		
			SIN4_1		
			INT05_1		
			TIOA13_2		
			IC00_1		
			MAD06_0		
101	85	J11	P1B	F	L
			AN11		
			SOT4_1		
			INT25_1		
			TIOB13_2		
			IC01_1		
102	86	J10	P1C	F	L
			AN12		
			SCK4_1		
			INT26_1		
			TIOA14_2		
			IC02_1		
103	87	J9	P1D	F	L
			AN13		
			CTS4_1		
			INT27_1		
			TIOB14_2		
			IC03_1		
104	88	H10	P1E	F	L
			AN14		
			RTS4_1		
			INT28_1		
			TIOA15_2		
			DTTIOX_1		
MAD10_0					

MB9B410T Series

Pin No			Pin name	I/O circuit type	Pin state type
LQFP-176	LQFP-144	BGA-192			
105	89	H9	PIF	F	L
			AN15		
			ADTG_5		
			INT29_1		
			TIOB15_2		
			FRCK0_1		
			MAD11_0		
106	90	J14	AVCC	-	
107	91	H14	AVRH	-	
108	92	G14	AVSS	-	
109	93	F14	VSS	-	
110	-	H13	PB0	F	L
			AN16		
			TIOA09_1		
			SIN7_2		
			INT16_0		
111	-	H12	PB1	F	L
			AN17		
			TIOB09_1		
			SOT7_2		
			INT17_0		
112	-	H11	PB2	F	L
			AN18		
			TIOA10_1		
			SCK7_2		
			INT18_0		
113	-	G13	PB3	F	L
			AN19		
			TIOB10_1		
			INT19_0		
114	-	G12	PB4	F	L
			AN20		
			TIOA11_1		
			SIN0_2		
			INT20_0		
115	-	G11	PB5	F	L
			AN21		
			TIOB11_1		
			SOT0_2		
			INT21_0		
			AIN2_2		
-	-	G7	VSS	-	
-	-	J7	VSS	-	

MB9B410T Series

Pin No			Pin name	I/O circuit type	Pin state type
LQFP-176	LQFP-144	BGA-192			
116	-	G10	PB6	F	L
			AN22		
			TIOA12_1		
			SCK0_2		
			INT22_0		
			BIN2_2		
117	-	G9	PB7	F	L
			AN23		
			TIOB12_1		
			INT23_0		
			ZIN2_2		
118	94	F10	P29	F	K
			AN24		
			MAD12_0		
119	95	F11	P28	F	L
			AN25		
			ADTG_4		
			INT09_0		
			RTO05_1		
			MAD13_0		
120	96	F12	P27	F	L
			AN26		
			INT02_2		
			RTO04_1		
			MAD14_0		
121	97	F13	P26	F	K
			AN27		
			SCK2_1		
			RTO03_1		
			MAD15_0		
122	98	E10	P25	F	K
			AN28		
			SOT2_1		
			TX1_0		
			RTO02_1		
			MAD16_0		
123	99	E11	P24	F	L
			AN29		
			SIN2_1		
			RX1_0		
			INT01_2		
			RTO01_1		
			MAD17_0		

MB9B410T Series

Pin No			Pin name	I/O circuit type	Pin state type
LQFP-176	LQFP-144	BGA-192			
124	100	E12	P23	F	K
			AN30		
			SCK0_0		
			TIOA07_1		
			RTO00_1		
125	101	E13	P22	F	K
			AN31		
			SOT0_0		
			TIOB07_1		
			ZIN1_1		
126	102	D12	P21	E	H
			SIN0_0		
			INT06_1		
			BIN1_1		
127	103	D13	P20	E	H
			INT05_0		
			CROUT_0		
			AIN1_1		
			MAD18_0		
128	104	C13	PF6	I*	J
			FRCK2_0		
			NMIX		
129	105	E14	VCC	-	
130	106	D14	P82	H	O
131	107	C14	P83	H	O
132	108	B14	VSS	-	
133	109	A13	VCC	-	
134	110	B13	P00	E	E
			TRSTX		
135	111	A12	P01	E	E
			TCK		
136	112	C12	P02	E	E
			TDI		
137	113	B12	P03	E	E
			TMS		
138	114	B11	P04	E	E
			TDO		
139	-	C11	P90	E	H
			TIOB08_0		
			RTO20_1		
			INT30_0		
			MAD19_0		
-	-	A8	VSS	-	

MB9B410T Series

Pin No			Pin name	I/O circuit type	Pin state type
LQFP-176	LQFP-144	BGA-192			
140	-	D11	P91	E	H
			TIOB09_0		
			RTO21_1		
			INT31_0		
			MAD20_0		
141	-	B10	P92	E	I
			TIOB10_0		
			RTO22_1		
			SIN5_1		
			MAD21_0		
142	-	C10	P93	E	I
			TIOB11_0		
			RTO23_1		
			SOT5_1		
			MAD22_0		
143	-	D10	P94	E	H
			TIOB12_0		
			RTO24_1		
			SCK5_1		
			INT26_0		
			MAD23_0		
144	-	B9	P95	E	H
			TIOB13_0		
			RTO25_1		
			INT27_0		
			MAD24_0		
145	115	C9	PC0	K	Q
146	116	B8	PC1	K	Q
147	117	D9	PC2	K	Q
148	118	E9	PC3	K	Q
			TIOA06_1		
149	119	F9	PC4	K	Q
			TIOA08_2		
150	120	C8	PC5	K	Q
			TIOA10_2		
-	-	A5	VSS	-	-

MB9B410T Series

Pin No			Pin name	I/O circuit type	Pin state type
LQFP-176	LQFP-144	BGA-192			
151	121	D8	PC6	K	Q
			TIOA14_0		
152	122	E8	PC7	L	Q
			CROUT_1		
153	123	A10	PC8	K	Q
154	124	F8	PC9	K	Q
155	125	B7	PCA	K	Q
156	126	A9	VCC	-	
157	127	A11	VSS	-	
158	128	A7	PCB	L	Q
159	129	C7	PCC	K	Q
160	130	A6	PCD	K	Q
161	131	D7	PCE	L	Q
			RTS4_0		
			TIOB06_1		
162	132	E7	PCF	L	Q
			CTS4_0		
			TIOB08_2		
163	133	F7	PD0	L	R
			SCK4_0		
			TIOB10_2		
			INT30_1		
164	134	B6	PD1	L	R
			SOT4_0		
			TIOB14_0		
			INT31_1		
-	-	N7	VSS	-	
-	-	G8	VSS	-	
-	-	H7	VSS	-	
-	-	H8	VSS	-	

MB9B410T Series

Pin No			Pin name	I/O circuit type	Pin state type
LQFP-176	LQFP-144	BGA-192			
165	135	C6	PD2	L	R
			SIN4_0		
			TIOA03_2		
			INT00_2		
166	136	D6	PD3	L	Q
			TIOB03_2		
167	137	E6	P62	E	Q
			SCK5_0		
			ADTG_3		
168	138	B5	P61	E	I
			SOT5_0		
			TIOB02_2		
169	139	C5	P60	E	H
			SIN5_0		
			TIOA02_2		
			INT15_1		
170	-	B4	PF3	I*	H
			TIOA06_0		
			SIN6_2		
			INT06_0		
			AIN2_1		
171	-	C4	PF4	I*	H
			TIOB06_0		
			SOT6_2		
			INT07_0		
			BIN2_1		
172	140	B3	PF5	I*	H
			SCK6_2		
			INT08_0		
			ZIN2_1		
173	141	A4	VCC	-	-
174	142	A3	P80	H	O
175	143	A2	P81	H	O
176	144	B1	VSS	-	-
-	-	M7	VSS	-	-

*: 5V tolerant I/O

MB9B410T Series

■ SIGNAL DESCRIPTION

The number after the underscore ("_") in pin names such as XXX_1 and XXX_2 indicates the relocated port number. For these pins, there are multiple pins that provide the same function for the same channel. Use the extended port function register (EPFR) to select the pin.

Module	Pin name	Function	Pin No		
			LQFP-176	LQFP-144	BGA-192
ADC	ADTG_0	A/D converter external trigger input pin	10	10	E2
	ADTG_1		18	18	F5
	ADTG_2		37	29	K2
	ADTG_3		167	137	E6
	ADTG_4		119	95	F11
	ADTG_5		105	89	H9
	ADTG_6		31	-	H6
	ADTG_7		49	41	L4
	ADTG_8		70	62	P8
	AN00	A/D converter analog input pin ANxx describes ADC ch.xx	90	74	M13
	AN01		91	75	M12
	AN02		92	76	L13
	AN03		93	77	L12
	AN04		94	78	L11
	AN05		95	79	K13
	AN06		96	80	K12
	AN07		97	81	K14
	AN08		98	82	K11
	AN09		99	83	J13
	AN10		100	84	J12
	AN11		101	85	J11
	AN12		102	86	J10
	AN13		103	87	J9
	AN14		104	88	H10
	AN15		105	89	H9
	AN16		110	-	H13
	AN17		111	-	H12
	AN18		112	-	H11
	AN19		113	-	G13
	AN20		114	-	G12
	AN21		115	-	G11
	AN22		116	-	G10
AN23	117		-	G9	
AN24	118		94	F10	
AN25	119		95	F11	
AN26	120		96	F12	
AN27	121		97	F13	
AN28	122		98	E10	
AN29	123		99	E11	
AN30	124		100	E12	
AN31	125	101	E13		

MB9B410T Series

Module	Pin name	Function	Pin No		
			LQFP-176	LQFP-144	BGA-192
Base Timer 0	TIOA0_0	Base timer ch.0 TIOA pin	46	38	N2
	TIOA0_1		38	30	K3
	TIOA0_2		11	11	E3
	TIOB0_0	Base timer ch.0 TIOB pin	59	51	L5
	TIOB0_1		28	-	H3
	TIOB0_2		12	12	E4
Base Timer 1	TIOA1_0	Base timer ch.1 TIOA pin	47	39	N3
	TIOA1_1		39	31	K4
	TIOA1_2		16	16	F3
	TIOB1_0	Base timer ch.1 TIOB pin	60	52	K5
	TIOB1_1		29	-	H4
	TIOB1_2		17	17	F4
Base Timer 2	TIOA2_0	Base timer ch.2 TIOA pin	48	40	M3
	TIOA2_1		40	32	L1
	TIOA2_2		169	139	C5
	TIOB2_0	Base timer ch.2 TIOB pin	61	53	N6
	TIOB2_1		30	-	H5
	TIOB2_2		168	138	B5
Base Timer 3	TIOA3_0	Base timer ch.3 TIOA pin	49	41	L4
	TIOA3_1		41	33	L2
	TIOA3_2		165	135	C6
	TIOB3_0	Base timer ch.3 TIOB pin	62	54	M6
	TIOB3_1		31	-	H6
	TIOB3_2		166	136	D6
Base Timer 4	TIOA4_0	Base timer ch.4 TIOA pin	50	42	M4
	TIOA4_1		42	34	L3
	TIOA4_2		65	57	J6
	TIOB4_0	Base timer ch.4 TIOB pin	63	55	L6
	TIOB4_1		32	-	J5
	TIOB4_2		66	58	N8
Base Timer 5	TIOA5_0	Base timer ch.5 TIOA pin	51	43	N4
	TIOA5_1		43	35	M2
	TIOA5_2		8	8	D3
	TIOB5_0	Base timer ch.5 TIOB pin	64	56	K6
	TIOB5_1		33	-	J4
	TIOB5_2		9	9	D4
Base Timer 6	TIOA6_0	Base timer ch.6 TIOA pin	170	-	B4
	TIOA6_1		148	118	E9
	TIOA6_2		25	-	H1
	TIOB6_0	Base timer ch.6 TIOB pin	171	-	C4
	TIOB6_1		161	131	D7
	TIOB6_2		26	-	H2

MB9B410T Series

Module	Pin name	Function	Pin No		
			LQFP-176	LQFP-144	BGA-192
Base Timer 7	TIOA07_0	Base timer ch.7 TIOA pin	77	-	P10
	TIOA07_1		124	100	E12
	TIOA07_2		71	63	J8
	TIOB07_0	Base timer ch.7 TIOB pin	76	-	K9
	TIOB07_1		125	101	E13
	TIOB07_2		72	64	P9
Base Timer 8	TIOA08_0	Base timer ch.8 TIOA pin	2	2	B2
	TIOA08_1		82	-	N11
	TIOA08_2		149	119	F9
	TIOB08_0	Base timer ch.8 TIOB pin	139	-	C11
	TIOB08_1		83	-	M11
	TIOB08_2		162	132	E7
Base Timer 9	TIOA09_0	Base timer ch.9 TIOA pin	3	3	C2
	TIOA09_1		110	-	H13
	TIOA09_2		19	19	F6
	TIOB09_0	Base timer ch.9 TIOB pin	140	-	D11
	TIOB09_1		111	-	H12
	TIOB09_2		20	20	G2
Base Timer 10	TIOA10_0	Base timer ch.10 TIOA pin	4	4	C3
	TIOA10_1		112	-	H11
	TIOA10_2		150	120	C8
	TIOB10_0	Base timer ch.10 TIOB pin	141	-	B10
	TIOB10_1		113	-	G13
	TIOB10_2		163	133	F7
Base Timer 11	TIOA11_0	Base timer ch.11 TIOA pin	5	5	D5
	TIOA11_1		114	-	G12
	TIOA11_2		21	21	G3
	TIOB11_0	Base timer ch.11 TIOB pin	142	-	C10
	TIOB11_1		115	-	G11
	TIOB11_2		22	22	G4
Base Timer 12	TIOA12_0	Base timer ch.12 TIOA pin	6	6	D2
	TIOA12_1		116	-	G10
	TIOA12_2		34	26	J3
	TIOB12_0	Base timer ch.12 TIOB pin	143	-	D10
	TIOB12_1		117	-	G9
	TIOB12_2		35	27	J2
Base Timer 13	TIOA13_0	Base timer ch.13 TIOA pin	7	7	D1
	TIOA13_1		23	23	G5
	TIOA13_2		100	84	J12
	TIOB13_0	Base timer ch.13 TIOB pin	144	-	B9
	TIOB13_1		24	24	G6
	TIOB13_2		101	85	J11

MB9B410T Series

Module	Pin name	Function	Pin No		
			LQFP-176	LQFP-144	BGA-192
Base Timer 14	TIOA14_0	Base timer ch.14 TIOA pin	151	121	D8
	TIOA14_1		78	-	N10
	TIOA14_2		102	86	J10
	TIOB14_0	Base timer ch.14 TIOB pin	164	134	B6
	TIOB14_1		79	-	L10
	TIOB14_2		103	87	J9
Base Timer 15	TIOA15_0	Base timer ch.15 TIOA pin	73	65	N9
	TIOA15_1		80	-	K10
	TIOA15_2		104	88	H10
	TIOB15_0	Base timer ch.15 TIOB pin	74	66	M9
	TIOB15_1		81	-	M10
	TIOB15_2		105	89	H9
CAN 0	TX0_0	CAN interface ch.0 TX output	65	57	J6
	TX0_1		32	-	J5
	TX0_2		7	7	D1
	RX0_0	CAN interface ch.0 RX output	66	58	N8
	RX0_1		33	-	J4
	RX0_2		6	6	D2
CAN 1	TX1_0	CAN interface ch.1 TX output	122	98	E10
	TX1_1		23	23	G5
	TX1_2		92	76	L13
	RX1_0	CAN interface ch.1 RX output	123	99	E11
	RX1_1		22	22	G4
	RX1_2		91	75	M12
Debugger	SWCLK	Serial wire debug interface clock input	135	111	A12
	SWDIO	Serial wire debug interface data input / output	137	113	B12
	SWO	Serial wire viewer output	138	114	B11
	TCK	J-TAG test clock input	135	111	A12
	TDI	J-TAG test data input	136	112	C12
	TDO	J-TAG debug data output	138	114	B11
	TMS	J-TAG test mode state input/output	137	113	B12
	TRACECLK	Trace CLK output of ETM	12	12	E4
	TRACED0	Trace data output of ETM	8	8	D3
	TRACED1		9	9	D4
	TRACED2		10	10	E2
	TRACED3		11	11	E3
	TRSTX		J-TAG test reset Input	134	110

MB9B410T Series

Module	Pin name	Function	Pin No		
			LQFP-176	LQFP-144	BGA-192
External Bus	MAD00_0	External bus interface address bus	94	78	L11
	MAD01_0		95	79	K13
	MAD02_0		96	80	K12
	MAD03_0		97	81	K14
	MAD04_0		98	82	K11
	MAD05_0		99	83	J13
	MAD06_0		100	84	J12
	MAD07_0		101	85	J11
	MAD08_0		102	86	J10
	MAD09_0		103	87	J9
	MAD10_0		104	88	H10
	MAD11_0		105	89	H9
	MAD12_0		118	94	F10
	MAD13_0		119	95	F11
	MAD14_0		120	96	F12
	MAD15_0		121	97	F13
	MAD16_0		122	98	E10
	MAD17_0		123	99	E11
	MAD18_0		127	103	D13
	MAD19_0		139	-	C11
	MAD20_0		140	-	D11
	MAD21_0		141	-	B10
	MAD22_0		142	-	C10
	MAD23_0		143	-	D10
	MAD24_0	144	-	B9	
	MCSX0_0	External bus interface chip select output pin	23	23	G5
	MCSX1_0		24	24	G6
	MCSX2_0		34	26	J3
	MCSX3_0		35	27	J2
	MCSX4_0		93	77	L12
	MCSX5_0		92	76	L13
	MCSX6_0		91	75	M12
MCSX7_0	90		74	M13	
MDQM0_0	External bus interface byte mask signal output	15	15	F2	
MDQM1_0		16	16	F3	
MOEX_0	External bus interface read enable signal for SRAM	13	13	E5	
MWEX_0	External bus interface write enable signal for SRAM	14	14	F1	

MB9B410T Series

Module	Pin name	Function	Pin No		
			LQFP-176	LQFP-144	BGA-192
External Bus	MNALE_0	External bus interface ALE signal to control NAND Flash output pin	19	19	F6
	MNCLE_0	External bus interface CLE signal to control NAND Flash output pin	20	20	G2
	MNREX_0	External bus interface read enable signal to control NAND Flash	22	22	G4
	MNWEX_0	External bus interface write enable signal to control NAND Flash	21	21	G3
	MADATA00_0	External bus interface data bus (Address / data multiplex bus)	60	52	K5
	MADATA01_0		61	53	N6
	MADATA02_0		62	54	M6
	MADATA03_0		63	55	L6
	MADATA04_0		64	56	K6
	MADATA05_0		65	57	J6
	MADATA06_0		66	58	N8
	MADATA07_0		67	59	M8
	MADATA08_0		68	60	L8
	MADATA09_0		69	61	K8
	MADATA10_0		70	62	P8
	MADATA11_0		71	63	J8
	MADATA12_0		72	64	P9
	MADATA13_0		73	65	N9
	MADATA14_0		74	66	M9
	MADATA15_0		75	67	L9
	MALE_0	External bus interface Address Latch enable output signal for multiplex	17	17	F4
	MRDY_0	External bus interface external RDY input signal	18	18	F5
	MCLKOUT_0	External bus interface external clock output	36	28	K1

MB9B410T Series

Module	Pin name	Function	Pin No		
			LQFP-176	LQFP-144	BGA-192
External Interrupt	INT00_0	External interrupt request 00 input pin	13	13	E5
	INT00_1		8	8	D3
	INT00_2		165	135	C6
	INT01_0	External interrupt request 01 input pin	14	14	F1
	INT01_1		9	9	D4
	INT01_2		123	99	E11
	INT02_0	External interrupt request 02 input pin	15	15	F2
	INT02_1		91	75	M12
	INT02_2		120	96	F12
	INT03_0	External interrupt request 03 input pin	6	6	D2
	INT03_1		94	78	L11
	INT03_2		28	-	H3
	INT04_0	External interrupt request 04 input pin	31	-	H6
	INT04_1		97	81	K14
	INT04_2		29	-	H4
	INT05_0	External interrupt request 05 input pin	127	103	D13
	INT05_1		100	84	J12
	INT05_2		30	-	H5
	INT06_0	External interrupt request 06 input pin	170	-	B4
	INT06_1		126	102	D12
	INT06_2		64	56	K6
	INT07_0	External interrupt request 07 input pin	171	-	C4
	INT07_1		70	62	P8
	INT07_2		16	16	F3
	INT08_0	External interrupt request 08 input pin	172	140	B3
	INT08_1		33	-	J4
	INT08_2		19	19	F6
	INT09_0	External interrupt request 09 input pin	119	95	F11
	INT09_1		34	26	J3
	INT09_2		22	22	G4
	INT10_0	External interrupt request 10 input pin	76	-	K9
	INT10_1		35	27	J2
	INT10_2		7	7	D1
	INT11_0	External interrupt request 11 input pin	77	-	P10
	INT11_1		36	28	K1
	INT11_2		71	63	J8
	INT12_0	External interrupt request 12 input pin	78	-	N10
	INT12_1		46	38	N2
	INT12_2		72	64	P9
	INT13_0	External interrupt request 13 input pin	81	-	M10
	INT13_1		47	39	N3
	INT13_2		66	58	N8
	INT14_0	External interrupt request 14 input pin	82	-	N11
	INT14_1		58	50	M5
	INT14_2		67	59	M8

MB9B410T Series

Module	Pin name	Function	Pin No		
			LQFP-176	LQFP-144	BGA-192
External Interrupt	INT15_0	External interrupt request 15 input pin	83	-	M11
	INT15_1		169	139	C5
	INT15_2		68	60	L8
	INT16_0	External interrupt request 16 input pin	110	-	H13
	INT16_1		20	20	G2
	INT17_0	External interrupt request 17 input pin	111	-	H12
	INT17_1		21	21	G3
	INT18_0	External interrupt request 18 input pin	112	-	H11
	INT18_1		23	23	G5
	INT19_0	External interrupt request 19 input pin	113	-	G13
	INT19_1		24	24	G6
	INT20_0	External interrupt request 20 input pin	114	-	G12
	INT20_1		96	80	K12
	INT21_0	External interrupt request 21 input pin	115	-	G11
	INT21_1		98	82	K11
	INT22_0	External interrupt request 22 input pin	116	-	G10
	INT22_1		99	83	J13
	INT23_0	External interrupt request 23 input pin	117	-	G9
	INT23_1		74	66	M9
	INT24_0	External interrupt request 24 input pin	79	-	L10
	INT24_1		75	67	L9
	INT25_0	External interrupt request 25 input pin	80	-	K10
	INT25_1		101	85	J11
	INT26_0	External interrupt request 26 input pin	143	-	D10
	INT26_1		102	86	J10
	INT27_0	External interrupt request 27 input pin	144	-	B9
	INT27_1		103	87	J9
	INT28_0	External interrupt request 28 input pin	25	-	H1
	INT28_1		104	88	H10
	INT29_0	External interrupt request 29 input pin	26	-	H2
	INT29_1		105	89	H9
	INT30_0	External interrupt request 30 input pin	139	-	C11
	INT30_1		163	133	F7
INT31_0	External interrupt request 31 input pin	140	-	D11	
INT31_1		164	134	B6	
NMIX	Non-Maskable Interrupt input	128	104	C13	

MB9B410T Series

Module	Pin name	Function	Pin No		
			LQFP-176	LQFP-144	BGA-192
GPIO	P00	General-purpose I/O port 0	134	110	B13
	P01		135	111	A12
	P02		136	112	C12
	P03		137	113	B12
	P04		138	114	B11
	P05		8	8	D3
	P06		9	9	D4
	P07		10	10	E2
	P08		11	11	E3
	P09		12	12	E4
	P10	General-purpose I/O port 1	90	74	M13
	P11		91	75	M12
	P12		92	76	L13
	P13		93	77	L12
	P14		94	78	L11
	P15		95	79	K13
	P16		96	80	K12
	P17		97	81	K14
	P18		98	82	K11
	P19		99	83	J13
	P1A	100	84	J12	
	P1B	101	85	J11	
	P1C	102	86	J10	
	P1D	103	87	J9	
	P1E	104	88	H10	
	P1F	105	89	H9	
	P20	General-purpose I/O port 2	127	103	D13
	P21		126	102	D12
	P22		125	101	E13
P23	124		100	E12	
P24	123		99	E11	
P25	122		98	E10	
P26	121		97	F13	
P27	120		96	F12	
P28	119		95	F11	
P29	118		94	F10	

MB9B410T Series

Module	Pin name	Function	Pin No		
			LQFP-176	LQFP-144	BGA-192
GPIO	P30	General-purpose I/O port 3	28	-	H3
	P31		29	-	H4
	P32		30	-	H5
	P33		31	-	H6
	P34		32	-	J5
	P35		33	-	J4
	P36		34	26	J3
	P37		35	27	J2
	P38		36	28	K1
	P39		37	29	K2
	P3A		38	30	K3
	P3B		39	31	K4
	P3C		40	32	L1
	P3D		41	33	L2
	P3E		42	34	L3
	P3F		43	35	M2
	P40		46	38	N2
	P41		47	39	N3
	P42	48	40	M3	
	P43	49	41	L4	
	P44	50	42	M4	
	P45	51	43	N4	
	P46	55	47	P5	
	P47	56	48	P6	
	P48	58	50	M5	
	P49	59	51	L5	
	P4A	60	52	K5	
	P4B	61	53	N6	
	P4C	62	54	M6	
	P4D	63	55	L6	
	P4E	64	56	K6	
	P50	13	General-purpose I/O port 5	13	13
P51	14	14		F1	
P52	15	15		F2	
P53	16	16		F3	
P54	17	17		F4	
P55	18	18		F5	
P56	19	19		F6	
P57	20	20		G2	
P58	21	21		G3	
P59	22	22		G4	
P5A	23	23		G5	
P5B	24	24		G6	
P5C	25	-		H1	
P5D	26	-		H2	

MB9B410T Series

Module	Pin name	Function	Pin No			
			LQFP-176	LQFP-144	BGA-192	
GPIO	P60	General-purpose I/O port 6	169	139	C5	
	P61		168	138	B5	
	P62		167	137	E6	
	P70	General-purpose I/O port 7	65	57	J6	
	P71		66	58	N8	
	P72		67	59	M8	
	P73		68	60	L8	
	P74		69	61	K8	
	P75		70	62	P8	
	P76		71	63	J8	
	P77		72	64	P9	
	P78		73	65	N9	
	P79		74	66	M9	
	P7A		75	67	L9	
	P7B		76	-	K9	
	P7C		77	-	P10	
	P7D		78	-	N10	
	P7E		79	-	L10	
	P7F		80	-	K10	
	P80		General-purpose I/O port 8	174	142	A3
	P81			175	143	A2
	P82	130		106	D14	
	P83	131		107	C14	
	P90	General-purpose I/O port 9	139	-	C11	
	P91		140	-	D11	
	P92		141	-	B10	
	P93		142	-	C10	
	P94		143	-	D10	
	P95		144	-	B9	
	PA0	General-purpose I/O port A	2	2	B2	
	PA1		3	3	C2	
	PA2		4	4	C3	
	PA3		5	5	D5	
	PA4		6	6	D2	
	PA5		7	7	D1	
	PB0	General-purpose I/O port B	110	-	H13	
	PB1		111	-	H12	
	PB2		112	-	H11	
	PB3		113	-	G13	
	PB4		114	-	G12	
	PB5		115	-	G11	
	PB6		116	-	G10	
PB7	117		-	G9		

MB9B410T Series

Module	Pin name	Function	Pin no		
			LQFP-176	LQFP-144	BGA-192
GPIO	PC0	General-purpose I/O port C	145	115	C9
	PC1		146	116	B8
	PC2		147	117	D9
	PC3		148	118	E9
	PC4		149	119	F9
	PC5		150	120	C8
	PC6		151	121	D8
	PC7		152	122	E8
	PC8		153	123	A10
	PC9		154	124	F8
	PCA		155	125	B7
	PCB		158	128	A7
	PCC		159	129	C7
	PCD		160	130	A6
	PCE		161	131	D7
	PCF		162	132	E7
	PD0		163	133	F7
	PD1	164	134	B6	
	PD2	165	135	C6	
	PD3	166	136	D6	
	PE0	84	68	N13	
	PE2	86	70	P12	
	PE3	87	71	P13	
	PF0	81	-	M10	
	PF1	82	-	N11	
	PF2	83	-	M11	
	PF3	170	-	B4	
	PF4	171	-	C4	
	PF5	172	140	B3	
	PF6	128	104	C13	

MB9B410T Series

Module	Pin name	Function	Pin No.		
			LQFP-176	LQFP-144	BGA-192
Multi Function Serial 0	SIN0_0	Multifunction serial interface ch.0 input pin	126	102	D12
	SIN0_1		94	78	L11
	SIN0_2		114	-	G12
	SOT0_0 (SDA0_0)	Multifunction serial interface ch.0 output pin. This pin operates as SOT0 when it is used in a UART/CSIO (operation modes 0 to 2) and as SDA0 when it is used in an I ² C (operation mode 4).	125	101	E13
	SOT0_1 (SDA0_1)		95	79	K13
	SOT0_2 (SDA0_2)		115	-	G11
	SCK0_0 (SCL0_0)	Multifunction serial interface ch.0 clock I/O pin. This pin operates as SCK0 when it is used in a UART/CSIO (operation modes 0 to 2) and as SCL0 when it is used in an I ² C (operation mode 4).	124	100	E12
SCK0_1 (SCL0_1)	96		80	K12	
SCK0_2 (SCL0_2)	116		-	G10	
Multi Function Serial 1	SIN1_0	Multifunction serial interface ch.1 input pin	19	19	F6
	SIN1_1		91	75	M12
	SIN1_2		81	-	M10
	SOT1_0 (SDA1_0)	Multifunction serial interface ch.1 output pin. This pin operates as SOT1 when it is used in a UART/CSIO (operation modes 0 to 2) and as SDA1 when it is used in an I ² C (operation mode 4).	20	20	G2
	SOT1_1 (SDA1_1)		92	76	L13
	SOT1_2 (SDA1_2)		82	-	N11
	SCK1_0 (SCL1_0)	Multifunction serial interface ch.1 clock I/O pin. This pin operates as SCK1 when it is used in a UART/CSIO (operation modes 0 to 2) and as SCL1 when it is used in an I ² C (operation mode 4).	21	21	G3
SCK1_1 (SCL1_1)	93		77	L12	
SCK1_2 (SCL1_2)	83		-	M11	

MB9B410T Series

Module	Pin name	Function	Pin No.		
			LQFP-176	LQFP-144	BGA-192
Multi Function Serial 2	SIN2_0	Multifunction serial interface ch.2 input pin	67	59	M8
	SIN2_1		123	99	E11
	SIN2_2		97	81	K14
	SOT2_0 (SDA2_0)	Multifunction serial interface ch.2 output pin. This pin operates as SOT2 when it is used in a UART/CSIO (operation modes 0 to 2) and as SDA2 when it is used in an I ² C (operation mode 4).	68	60	L8
	SOT2_1 (SDA2_1)		122	98	E10
	SOT2_2 (SDA2_2)		98	82	K11
	SCK2_0 (SCL2_0)	Multifunction serial interface ch.2 clock I/O pin. This pin operates as SCK2 when it is used in a UART/CSIO (operation modes 0 to 2) and as SCL2 when it is used in an I ² C (operation mode 4).	69	61	K8
	SCK2_1 (SCL2_1)		121	97	F13
	SCK2_2 (SCL2_2)		99	83	J13
Multi Function Serial 3	SIN3_0	Multifunction serial interface ch.3 input pin	70	62	P8
	SIN3_1		13	13	E5
	SIN3_2		58	50	M5
	SOT3_0 (SDA3_0)	Multifunction serial interface ch.3 output pin. This pin operates as SOT3 when it is used in a UART/CSIO (operation modes 0 to 2) and as SDA3 when it is used in an I ² C (operation mode 4).	71	63	J8
	SOT3_1 (SDA3_1)		14	14	F1
	SOT3_2 (SDA3_2)		59	51	L5
	SCK3_0 (SCL3_0)	Multifunction serial interface ch.3 clock I/O pin. This pin operates as SCK3 when it is used in a UART/CSIO (operation modes 0 to 2) and as SCL3 when it is used in an I ² C (operation mode 4).	72	64	P9
	SCK3_1 (SCL3_1)		15	15	F2
	SCK3_2 (SCL3_2)		60	52	K5

MB9B410T Series

Module	Pin name	Function	Pin No		
			LQFP-176	LQFP-144	BGA-192
Multi Function Serial 4	SIN4_0	Multifunction serial interface ch.4 input pin	165	135	C6
	SIN4_1		100	84	J12
	SIN4_2		8	8	D3
	SOT4_0 (SDA4_0)	Multifunction serial interface ch.4 output pin. This pin operates as SOT4 when it is used in a UART/CSIO (operation modes 0 to 2) and as SDA4 when it is used in an I ² C (operation mode 4).	164	134	B6
	SOT4_1 (SDA4_1)		101	85	J11
	SOT4_2 (SDA4_2)		9	9	D4
	SCK4_0 (SCL4_0)	Multifunction serial interface ch.4 clock I/O pin. This pin operates as SCK4 when it is used in a UART/CSIO (operation modes 0 to 2) and as SCL4 when it is used in an I ² C (operation mode 4).	163	133	F7
	SCK4_1 (SCL4_1)		102	86	J10
	SCK4_2 (SCL4_2)		10	10	E2
	RTS4_0	Multifunction serial interface ch.4 RTS output pin	161	131	D7
	RTS4_1		104	88	H10
	RTS4_2		12	12	E4
	CTS4_0	Multifunction serial interface ch.4 CTS input pin	162	132	E7
	CTS4_1		103	87	J9
	CTS4_2		11	11	E3
Multi Function Serial 5	SIN5_0	Multifunction serial interface ch.5 input pin	169	139	C5
	SIN5_1		141	-	B10
	SIN5_2		34	26	J3
	SOT5_0 (SDA5_0)	Multifunction serial interface ch.5 output pin. This pin operates as SOT5 when it is used in a UART/CSIO (operation modes 0 to 2) and as SDA5 when it is used in an I ² C (operation mode 4).	168	138	B5
	SOT5_1 (SDA5_1)		142	-	C10
	SOT5_2 (SDA5_2)		35	27	J2
	SCK5_0 (SCL5_0)	Multifunction serial interface ch.5 clock I/O pin. This pin operates as SCK5 when it is used in a UART/CSIO (operation modes 0 to 2) and as SCL5 when it is used in an I ² C (operation mode 4).	167	137	E6
	SCK5_1 (SCL5_1)		143	-	D10
	SCK5_2 (SCL5_2)		36	28	K1

MB9B410T Series

Module	Pin name	Function	Pin No		
			LQFP-176	LQFP-144	BGA-192
Multi Function Serial 6	SIN6_0	Multifunction serial interface ch.6 input pin	16	16	F3
	SIN6_1		31	-	H6
	SIN6_2		170	-	B4
	SOT6_0 (SDA6_0)	Multifunction serial interface ch.6 output pin. This pin operates as SOT6 when it is used in a UART/CSIO (operation modes 0 to 2) and as SDA6 when it is used in an I ² C (operation mode 4).	17	17	F4
	SOT6_1 (SDA6_1)		30	-	H5
	SOT6_2 (SDA6_2)		171	-	C4
	SCK6_0 (SCL6_0)	Multifunction serial interface ch.6 clock I/O pin. This pin operates as SCK6 when it is used in a UART/CSIO (operation modes 0 to 2) and as SCL6 when it is used in an I ² C (operation mode 4).	18	18	F5
	SCK6_1 (SCL6_1)		29	-	H4
	SCK6_2 (SCL6_2)		172	140	B3
	Multi Function Serial 7	SIN7_0	Multifunction serial interface ch.7 input pin	22	22
SIN7_1		64		56	K6
SIN7_2		110		-	H13
SOT7_0 (SDA7_0)		Multifunction serial interface ch.7 output pin. This pin operates as SOT7 when it is used in a UART/CSIO (operation modes 0 to 2) and as SDA7 when it is used in an I ² C (operation mode 4).	23	23	G5
SOT7_1 (SDA7_1)			63	55	L6
SOT7_2 (SDA7_2)			111	-	H12
SCK7_0 (SCL7_0)		Multifunction serial interface ch.7 clock I/O pin. This pin operates as SCK7 when it is used in a UART/CSIO (operation modes 0 to 2) and as SCL7 when it is used in an I ² C (operation mode 4).	24	24	G6
SCK7_1 (SCL7_1)			62	54	M6
SCK7_2 (SCL7_2)			112	-	H11

MB9B410T Series

Module	Pin name	Function	Pin No			
			LQFP-176	LQFP-144	BGA-192	
Multi Function Timer 0	DTTI0X_0	Input signal controlling wave form generator outputs RTO00 to RTO05 of multi-function timer 0.	37	29	K2	
	DTTI0X_1		104	88	H10	
	FRCK0_0	16-bit free-run timer ch.0 external clock input pin	32	-	J5	
	FRCK0_1		105	89	H9	
	FRCK0_2		91	75	M12	
	IC00_0	16-bit input capture ch.0 input pin of multi-function timer 0 ICxx describes channel number.	36	28	K1	
	IC00_1		100	84	J12	
	IC00_2		92	76	L13	
	IC01_0		35	27	J2	
	IC01_1		101	85	J11	
	IC01_2		93	77	L12	
	IC02_0		34	26	J3	
	IC02_1		102	86	J10	
	IC02_2		94	78	L11	
	IC03_0		33	-	J4	
	IC03_1		103	87	J9	
	IC03_2		95	79	K13	
	RTO00_0 (PPG00_0)		Wave form generator output of multi-function timer 0	38	30	K3
	RTO00_1 (PPG00_1)		This pin operates as PPG00 when it is used in PPG0 output modes.	124	100	E12
	RTO01_0 (PPG00_0)		Wave form generator output of multi-function timer 0	39	31	K4
	RTO01_1 (PPG00_1)	This pin operates as PPG00 when it is used in PPG0 output modes.	123	99	E11	
	RTO02_0 (PPG02_0)	Wave form generator output of multi-function timer 0	40	32	L1	
	RTO02_1 (PPG02_1)	This pin operates as PPG02 when it is used in PPG0 output modes.	122	98	E10	
	RTO03_0 (PPG02_0)	Wave form generator output of multi-function timer 0	41	33	L2	
	RTO03_1 (PPG02_1)	This pin operates as PPG02 when it is used in PPG0 output modes.	121	97	F13	
	RTO04_0 (PPG04_0)	Wave form generator output of multi-function timer 0	42	34	L3	
	RTO04_1 (PPG04_1)	This pin operates as PPG04 when it is used in PPG0 output modes.	120	96	F12	
	RTO05_0 (PPG04_0)	Wave form generator output of multi-function timer 0	43	35	M2	
	RTO05_1 (PPG04_1)	This pin operates as PPG04 when it is used in PPG0 output modes.	119	95	F11	

MB9B410T Series

Module	Pin name	Function	Pin No			
			LQFP-176	LQFP-144	BGA-192	
Multi Function Timer 1	DTTI1X_0	Input signal controlling wave form generator outputs RTO10 to RTO15 of multi-function timer 1.	19	19	F6	
	DTTI1X_1		58	50	M5	
	FRCK1_0	16-bit free-run timer ch.1 external clock input pin	2	2	B2	
	FRCK1_1		63	55	L6	
	IC10_0	16-bit input capture ch.1 input pin of multi-function timer 1. ICxx describes channel number	3	3	C2	
	IC10_1		59	51	L5	
	IC11_0		4	4	C3	
	IC11_1		60	52	K5	
	IC12_0		5	5	D5	
	IC12_1		61	53	N6	
	IC13_0		6	6	D2	
	IC13_1		62	54	M6	
	RTO10_0 (PPG10_0)		Wave form generator output of multi-function timer 1. This pin operates as PPG10 when it is used in PPG1 output modes.	13	13	E5
	RTO10_1 (PPG10_1)			46	38	N2
	RTO11_0 (PPG10_0)	Wave form generator output of multi-function timer 1. This pin operates as PPG10 when it is used in PPG1 output modes.	14	14	F1	
	RTO11_1 (PPG10_1)		47	39	N3	
	RTO12_0 (PPG12_0)	Wave form generator output of multi-function timer 1. This pin operates as PPG12 when it is used in PPG1 output modes.	15	15	F2	
	RTO12_1 (PPG12_1)		48	40	M3	
	RTO13_0 (PPG12_0)	Wave form generator output of multi-function timer 1. This pin operates as PPG12 when it is used in PPG1 output modes.	16	16	F3	
	RTO13_1 (PPG12_1)		49	41	L4	
	RTO14_0 (PPG14_0)	Wave form generator output of multi-function timer 1. This pin operates as PPG14 when it is used in PPG1 output modes.	17	17	F4	
	RTO14_1 (PPG14_1)		50	42	M4	
	RTO15_0 (PPG14_0)	Wave form generator output of multi-function timer 1. This pin operates as PPG14 when it is used in PPG1 output modes.	18	18	F5	
	RTO15_1 (PPG14_1)		51	43	N4	

MB9B410T Series

Module	Pin name	Function	Pin No		
			LQFP-176	LQFP-144	BGA-192
Multi Function Timer 2	DTTI2X_0	Input signal controlling wave form generator outputs RTO20 to RTO25 of multi-function timer 2.	12	12	E4
	DTTI2X_1		26	-	H2
	FRCK2_0	16-bit free-run timer ch.2 external clock input pin	128	104	C13
	FRCK2_1		78	-	N10
	IC20_0	16-bit input capture ch.2 input pin of multi-function timer 2. ICxx describes channel number.	13	13	E5
	IC20_1		25	-	H1
	IC21_0		14	14	F1
	IC21_1		79	-	L10
	IC22_0		15	15	F2
	IC22_1		80	-	K10
	IC23_0		16	16	F3
	IC23_1		81	-	M10
	RTO20_0 (PPG20_0)	Wave form generator output of multi-function timer 2.	2	2	B2
	RTO20_1 (PPG20_1)	This pin operates as PPG20 when it is used in PPG2 output modes.	139	-	C11
	RTO21_0 (PPG20_0)	Wave form generator output of multi-function timer 2.	3	3	C2
	RTO21_1 (PPG20_1)	This pin operates as PPG20 when it is used in PPG2 output modes.	140	-	D11
	RTO22_0 (PPG22_0)	Wave form generator output of multi-function timer 2.	4	4	C3
	RTO22_1 (PPG22_1)	This pin operates as PPG22 when it is used in PPG2 output modes.	141	-	B10
	RTO23_0 (PPG22_0)	Wave form generator output of multi-function timer 2.	5	5	D5
	RTO23_1 (PPG22_1)	This pin operates as PPG22 when it is used in PPG2 output modes.	142	-	C10
	RTO24_0 (PPG24_0)	Wave form generator output of multi-function timer 2.	6	6	D2
	RTO24_1 (PPG24_1)	This pin operates as PPG24 when it is used in PPG2 output modes.	143	-	D10
	RTO25_0 (PPG24_0)	Wave form generator output of multi-function timer 2.	7	7	D1
	RTO25_1 (PPG24_1)	This pin operates as PPG24 when it is used in PPG2 output modes.	144	-	B9

MB9B410T Series

Module	Pin name	Function	Pin No		
			LQFP-176	LQFP-144	BGA-192
Quadrature Position/ Revolution Counter 0	AIN0_0	QPRC ch.0 AIN input pin	28	-	H3
	AIN0_1		59	51	L5
	AIN0_2		13	13	E5
	BIN0_0	QPRC ch.0 BIN input pin	29	-	H4
	BIN0_1		60	52	K5
	BIN0_2		14	14	F1
	ZIN0_0	QPRC ch.0 ZIN input pin	30	-	H5
	ZIN0_1		61	53	N6
	ZIN0_2		15	15	F2
Quadrature Position/ Revolution Counter 1	AIN1_0	QPRC ch.1 AIN input pin	73	65	N9
	AIN1_1		127	103	D13
	AIN1_2		62	54	M6
	BIN1_0	QPRC ch.1 BIN input pin	74	66	M9
	BIN1_1		126	102	D12
	BIN1_2		63	55	L6
	ZIN1_0	QPRC ch.1 ZIN input pin	75	67	L9
	ZIN1_1		125	101	E13
	ZIN1_2		64	56	K6
Quadrature Position/ Revolution Counter 2	AIN2_0	QPRC ch.2 AIN input pin	67	59	M8
	AIN2_1		170	-	B4
	AIN2_2		115	-	G11
	BIN2_0	QPRC ch.2 BIN input pin	68	60	L8
	BIN2_1		171	-	C4
	BIN2_2		116	-	G10
	ZIN2_0	QPRC ch.2 ZIN input pin	69	61	K8
	ZIN2_1		172	140	B3
	ZIN2_2		117	-	G9

MB9B410T Series

Module	Pin name	Function	Pin No		
			LQFP-176	LQFP-144	BGA-192
RESET	INITX	External Reset Input. A reset is valid when INITX="L".	57	49	N5
Mode	MD0	Mode 0 Pin. During normal operation, MD0="L" must be input. During serial programming to Flash memory, MD0="H" must be input.	85	69	N12
	MD1	Mode 1 Pin. During serial programming to Flash memory, MD1="L" must be input.	84	68	N13
POWER	VCC	Power supply Pin	1	1	C1
	VCC	Power supply Pin	45	37	N1
	VCC	Power supply Pin	54	46	P4
	VCC	Power supply Pin	89	73	M14
	VCC	Power supply Pin	133	109	A13
	VCC	Power supply Pin	173	141	A4
	VCC	Power supply Pin	129	105	E14
	VCC	Power supply Pin	156	126	A9
GND	VSS	GND Pin	27	25	J1
	VSS	GND Pin	44	36	M1
	VSS	GND Pin	53	45	P3
	VSS	GND Pin	88	72	N14
	VSS	GND Pin	109	93	F14
	VSS	GND Pin	132	108	B14
	VSS	GND Pin	157	127	A11
	VSS	GND Pin	176	144	B1
	VSS	GND Pin	-	-	E1
	VSS	GND Pin	-	-	G1
	VSS	GND Pin	-	-	P7
	VSS	GND Pin	-	-	P11
	VSS	GND Pin	-	-	L14
	VSS	GND Pin	-	-	A8
	VSS	GND Pin	-	-	A5
	VSS	GND Pin	-	-	N7
	VSS	GND Pin	-	-	M7
	VSS	GND Pin	-	-	L7
	VSS	GND Pin	-	-	K7
	VSS	GND Pin	-	-	J7
	VSS	GND Pin	-	-	G7
	VSS	GND Pin	-	-	H7
	VSS	GND Pin	-	-	H8
	VSS	GND Pin	-	-	G8

MB9B410T Series

Module	Pin name	Function	Pin No.		
			LQFP-176	LQFP-144	BGA-192
CLOCK	X0	Main clock (oscillation) input pin	86	70	P12
	X0A	Sub clock (oscillation) input pin	55	47	P5
	X1	Main clock (oscillation) I/O pin	87	71	P13
	X1A	Sub clock (oscillation) I/O pin	56	48	P6
	CROUT_0	Internal CR-osc clock output port	127	103	D13
	CROUT_1		152	122	E8
ADC POWER	AVCC	A/D converter analog power pin	106	90	J14
	AVRH	A/D converter analog reference voltage input pin	107	91	H14
ADC GND	AVSS	A/D converter GND pin	108	92	G14
C pin	C	Power stabilization capacity pin	52	44	P2

*: 5V tolerant I/O

MB9B410T Series

■ I/O CIRCUIT TYPE

Type	Circuit	Remarks
A		<p>It is possible to select the main oscillation / GPIO function</p> <p>When the main oscillation is selected.</p> <ul style="list-style-type: none"> • Oscillation feedback resistor : Approximately 1MΩ • With Standby mode control <p>When the GPIO is selected.</p> <ul style="list-style-type: none"> • CMOS level output. • CMOS level hysteresis input • With pull-up resistor control • With standby mode control • Pull-up resistor : Approximately 50kΩ • $I_{OH} = -4\text{mA}$, $I_{OL} = 4\text{mA}$
B		<ul style="list-style-type: none"> • CMOS level hysteresis input • Pull-up resistor : Approximately 50kΩ

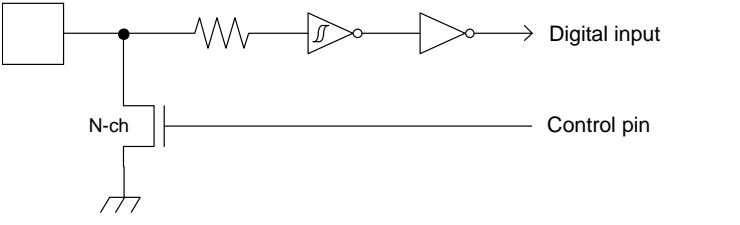
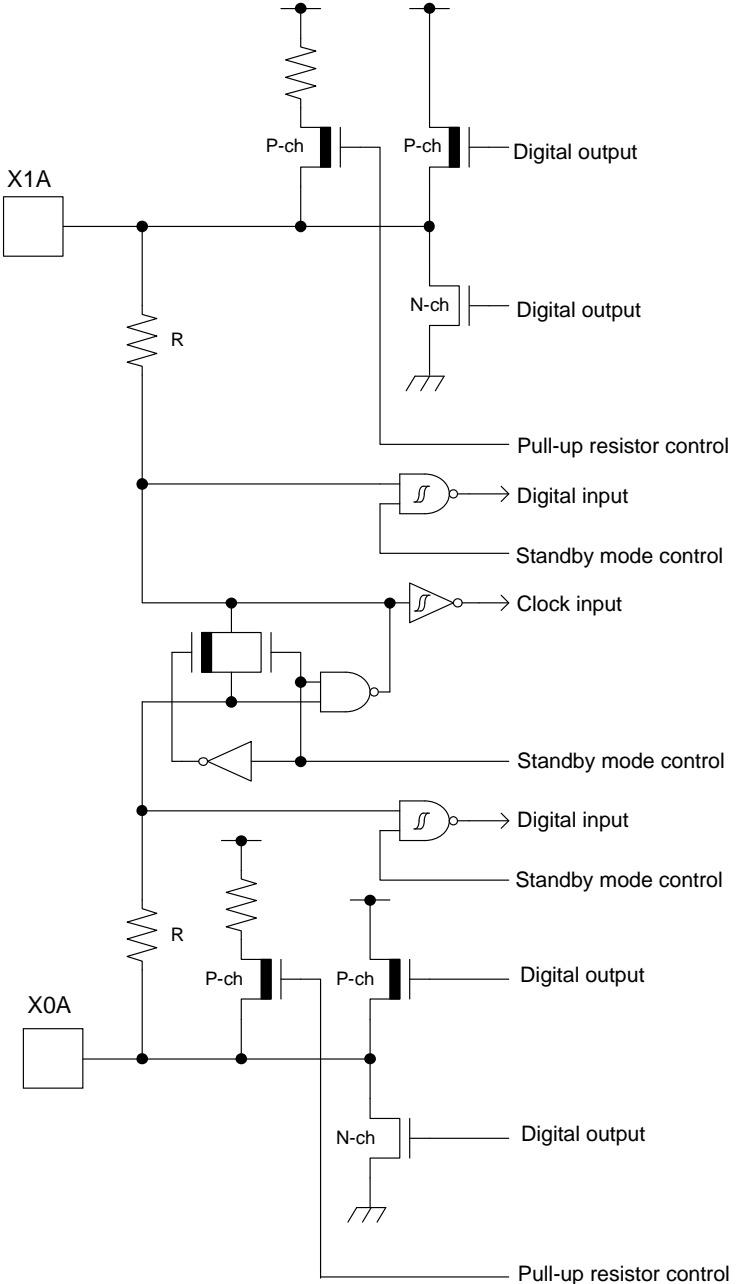
Type	Circuit	Remarks
C		<ul style="list-style-type: none"> • Open drain output • CMOS level hysteresis input
D		<p>It is possible to select the sub oscillation / GPIO function</p> <p>When the sub oscillation is selected.</p> <ul style="list-style-type: none"> • Oscillation feedback resistor : Approximately 5MΩ • With Standby mode control <p>When the GPIO is selected.</p> <ul style="list-style-type: none"> • CMOS level output. • CMOS level hysteresis input • With pull-up resistor control • With standby mode control • Pull-up resistor : Approximately 50kΩ • $I_{OH} = -4\text{mA}$, $I_{OL} = 4\text{mA}$

MB9B410T Series

Type	Circuit	Remarks
E	<p>The circuit diagram for Type E shows a CMOS output stage. It includes a pull-up resistor R connected to a supply rail. The output node is connected to a P-channel MOSFET (P-ch) and an N-channel MOSFET (N-ch). The P-ch MOSFET is controlled by a 'Pull-up resistor control' signal. The N-ch MOSFET is controlled by a 'Standby mode control' signal. The output node is also connected to a 'Digital output' terminal. A 'Digital input' terminal is connected to the output node through an AND gate, which is also controlled by the 'Standby mode control' signal.</p>	<ul style="list-style-type: none"> • CMOS level output • CMOS level hysteresis input • With pull-up resistor control • With standby mode control • Pull-up resistor : Approximately 50kΩ • $I_{OH} = -4\text{mA}$, $I_{OL} = 4\text{mA}$
F	<p>The circuit diagram for Type F shows a CMOS output stage similar to Type E, but with additional features. It includes a pull-up resistor R connected to a supply rail. The output node is connected to a P-channel MOSFET (P-ch) and an N-channel MOSFET (N-ch). The P-ch MOSFET is controlled by a 'Pull-up resistor control' signal. The N-ch MOSFET is controlled by a 'Standby mode control' signal. The output node is also connected to a 'Digital output' terminal. A 'Digital input' terminal is connected to the output node through an AND gate, which is also controlled by the 'Standby mode control' signal. An 'Analog input' terminal is connected to the output node through an AND gate, which is also controlled by the 'Standby mode control' signal. An 'Input control' signal is connected to the output node through an AND gate, which is also controlled by the 'Standby mode control' signal.</p>	<ul style="list-style-type: none"> • CMOS level output • CMOS level hysteresis input • With input control • Analog input • With pull-up resistor control • With standby mode control • Pull-up resistor : Approximately 50kΩ • $I_{OH} = -4\text{mA}$, $I_{OL} = 4\text{mA}$

MB9B410T Series

Type	Circuit	Remarks
G	<p>The diagram for Type G shows a CMOS output stage. A pull-up resistor is connected to the output node. The output node is also connected to the input of an AND gate. The other input of the AND gate is the standby mode control signal. The output of the AND gate is the digital input signal. The output node is also connected to the input of another AND gate. The other input of this AND gate is the pull-up resistor control signal. The output of this AND gate is the digital output signal. The output node is also connected to the input of a third AND gate. The other input of this AND gate is the pull-up resistor control signal. The output of this AND gate is the digital output signal. The output node is also connected to the input of a fourth AND gate. The other input of this AND gate is the pull-up resistor control signal. The output of this AND gate is the digital output signal.</p>	<ul style="list-style-type: none"> • CMOS level output • CMOS level hysteresis input • With pull-up resistor control • With standby mode control • Pull-up resistor : Approximately 50kΩ • $I_{OH} = -12\text{mA}$, $I_{OL} = 12\text{mA}$
H	<p>The diagram for Type H shows a CMOS output stage. A pull-up resistor is connected to the output node. The output node is also connected to the input of an AND gate. The other input of the AND gate is the standby mode control signal. The output of the AND gate is the digital input signal. The output node is also connected to the input of another AND gate. The other input of this AND gate is the standby mode control signal. The output of this AND gate is the digital output signal. The output node is also connected to the input of a third AND gate. The other input of this AND gate is the standby mode control signal. The output of this AND gate is the digital output signal. The output node is also connected to the input of a fourth AND gate. The other input of this AND gate is the standby mode control signal. The output of this AND gate is the digital output signal.</p>	<ul style="list-style-type: none"> • CMOS level output • CMOS level hysteresis input • With standby mode control • $I_{OH} = -20.5\text{mA}$, $I_{OL} = 18.5\text{mA}$

MB9B410T Series

Type	Circuit	Remarks
I		<ul style="list-style-type: none"> • CMOS level output • CMOS level hysteresis input • 5V tolerant • With standby mode control • $I_{OH} = -4\text{mA}$, $I_{OL} = 4\text{mA}$ • Available to control PZR registers.
J		<p>CMOS level hysteresis input</p>
K		<ul style="list-style-type: none"> • CMOS level output • TTL level hysteresis input • With pull-up resistor control • With standby mode control • Pull-up resistor : Approximately 50kΩ • $I_{OH} = -4\text{mA}$, $I_{OL} = 4\text{mA}$

MB9B410T Series

Type	Circuit	Remarks
L	<p>The circuit diagram shows a CMOS output stage. A pull-up resistor (R) is connected to the output node. The output node is driven by a P-channel MOSFET (P-ch) and an N-channel MOSFET (N-ch). The P-channel MOSFET is controlled by a 'Pull-up resistor control' signal. The N-channel MOSFET is controlled by a 'Standby mode control' signal. The output node is also connected to a 'Digital output' terminal. A 'Digital input' terminal is connected to the output node through an AND gate, which is also controlled by the 'Standby mode control' signal.</p>	<ul style="list-style-type: none"> • CMOS level output • CMOS level hysteresis input • With pull-up resistor control • With standby mode control • Pull-up resistor : Approximately 50kΩ • $I_{OH} = -8\text{mA}$, $I_{OL} = 8\text{mA}$

■ HANDLING PRECAUTIONS

Any semiconductor devices have inherently a certain rate of failure. The possibility of failure is greatly affected by the conditions in which they are used (circuit conditions, environmental conditions, etc.). This page describes precautions that must be observed to minimize the chance of failure and to obtain higher reliability from your FUJITSU SEMICONDUCTOR semiconductor devices.

1. Precautions for Product Design

This section describes precautions when designing electronic equipment using semiconductor devices.

- **Absolute Maximum Ratings**

Semiconductor devices can be permanently damaged by application of stress (voltage, current, temperature, etc.) in excess of certain established limits, called absolute maximum ratings. Do not exceed these ratings.

- **Recommended Operating Conditions**

Recommended operating conditions are normal operating ranges for the semiconductor device. All the device's electrical characteristics are warranted when operated within these ranges.

Always use semiconductor devices within the recommended operating conditions. Operation outside these ranges may adversely affect reliability and could result in device failure.

No warranty is made with respect to uses, operating conditions, or combinations not represented on the data sheet. Users considering application outside the listed conditions are advised to contact their sales representative beforehand.

- **Processing and Protection of Pins**

These precautions must be followed when handling the pins which connect semiconductor devices to power supply and input/output functions.

- (1) **Preventing Over-Voltage and Over-Current Conditions**

Exposure to voltage or current levels in excess of maximum ratings at any pin is likely to cause deterioration within the device, and in extreme cases leads to permanent damage of the device. Try to prevent such overvoltage or over-current conditions at the design stage.

- (2) **Protection of Output Pins**

Shorting of output pins to supply pins or other output pins, or connection to large capacitance can cause large current flows. Such conditions if present for extended periods of time can damage the device.

Therefore, avoid this type of connection.

- (3) **Handling of Unused Input Pins**

Unconnected input pins with very high impedance levels can adversely affect stability of operation. Such pins should be connected through an appropriate resistance to a power supply pin or ground pin.

- **Latch-up**

Semiconductor devices are constructed by the formation of P-type and N-type areas on a substrate. When subjected to abnormally high voltages, internal parasitic PNP junctions (called thyristor structures) may be formed, causing large current levels in excess of several hundred mA to flow continuously at the power supply pin. This condition is called latch-up.

CAUTION: The occurrence of latch-up not only causes loss of reliability in the semiconductor device, but can cause injury or damage from high heat, smoke or flame. To prevent this from happening, do the following:

- (1) Be sure that voltages applied to pins do not exceed the absolute maximum ratings. This should include attention to abnormal noise, surge levels, etc.
- (2) Be sure that abnormal current flows do not occur during the power-on sequence.

- **Observance of Safety Regulations and Standards**

Most countries in the world have established standards and regulations regarding safety, protection from electromagnetic interference, etc. Customers are requested to observe applicable regulations and standards in the design of products.

- **Fail-Safe Design**

Any semiconductor devices have inherently a certain rate of failure. You must protect against injury, damage or loss from such failures by incorporating safety design measures into your facility and equipment such as redundancy, fire protection, and prevention of over-current levels and other abnormal operating conditions.

- **Precautions Related to Usage of Devices**

FUJITSU SEMICONDUCTOR semiconductor devices are intended for use in standard applications (computers, office automation and other office equipment, industrial, communications, and measurement equipment, personal or household devices, etc.).

CAUTION: Customers considering the use of our products in special applications where failure or abnormal operation may directly affect human lives or cause physical injury or property damage, or where extremely high levels of reliability are demanded (such as aerospace systems, atomic energy controls, sea floor repeaters, vehicle operating controls, medical devices for life support, etc.) are requested to consult with sales representatives before such use. The company will not be responsible for damages arising from such use without prior approval.

2. Precautions for Package Mounting

Package mounting may be either lead insertion type or surface mount type. In either case, for heat resistance during soldering, you should only mount under FUJITSU SEMICONDUCTOR's recommended conditions. For detailed information about mount conditions, contact your sales representative.

- **Lead Insertion Type**

Mounting of lead insertion type packages onto printed circuit boards may be done by two methods: direct soldering on the board, or mounting by using a socket.

Direct mounting onto boards normally involves processes for inserting leads into through-holes on the board and using the flow soldering (wave soldering) method of applying liquid solder. In this case, the soldering process usually causes leads to be subjected to thermal stress in excess of the absolute ratings for storage temperature. Mounting processes should conform to FUJITSU SEMICONDUCTOR recommended mounting conditions.

If socket mounting is used, differences in surface treatment of the socket contacts and IC lead surfaces can lead to contact deterioration after long periods. For this reason it is recommended that the surface treatment of socket contacts and IC leads be verified before mounting.

- **Surface Mount Type**

Surface mount packaging has longer and thinner leads than lead-insertion packaging, and therefore leads are more easily deformed or bent. The use of packages with higher pin counts and narrower pin pitch results in increased susceptibility to open connections caused by deformed pins, or shorting due to solder bridges.

You must use appropriate mounting techniques. FUJITSU SEMICONDUCTOR recommends the solder reflow method, and has established a ranking of mounting conditions for each product. Users are advised to mount packages in accordance with FUJITSU SEMICONDUCTOR ranking of recommended conditions.

MB9B410T Series

- **Lead-Free Packaging**

CAUTION: When ball grid array (BGA) packages with Sn-Ag-Cu balls are mounted using Sn-Pb eutectic soldering, junction strength may be reduced under some conditions of use.

- **Storage of Semiconductor Devices**

Because plastic chip packages are formed from plastic resins, exposure to natural environmental conditions will cause absorption of moisture. During mounting, the application of heat to a package that has absorbed moisture can cause surfaces to peel, reducing moisture resistance and causing packages to crack. To prevent, do the following:

- (1) Avoid exposure to rapid temperature changes, which cause moisture to condense inside the product. Store products in locations where temperature changes are slight.
- (2) Use dry boxes for product storage. Products should be stored below 70% relative humidity, and at temperatures between 5°C and 30°C.
When you open Dry Package that recommends humidity 40% to 70% relative humidity.
- (3) When necessary, FUJITSU SEMICONDUCTOR packages semiconductor devices in highly moisture-resistant aluminum laminate bags, with a silica gel desiccant. Devices should be sealed in their aluminum laminate bags for storage.
- (4) Avoid storing packages where they are exposed to corrosive gases or high levels of dust.

- **Baking**

Packages that have absorbed moisture may be de-moisturized by baking (heat drying). Follow the FUJITSU SEMICONDUCTOR recommended conditions for baking.

Condition: 125°C/24 h

- **Static Electricity**

Because semiconductor devices are particularly susceptible to damage by static electricity, you must take the following precautions:

- (1) Maintain relative humidity in the working environment between 40% and 70%. Use of an apparatus for ion generation may be needed to remove electricity.
- (2) Electrically ground all conveyors, solder vessels, soldering irons and peripheral equipment.
- (3) Eliminate static body electricity by the use of rings or bracelets connected to ground through high resistance (on the level of 1 MΩ).
Wearing of conductive clothing and shoes, use of conductive floor mats and other measures to minimize shock loads is recommended.
- (4) Ground all fixtures and instruments, or protect with anti-static measures.
- (5) Avoid the use of styrofoam or other highly static-prone materials for storage of completed board assemblies.

3. Precautions for Use Environment

Reliability of semiconductor devices depends on ambient temperature and other conditions as described above.

For reliable performance, do the following:

(1) Humidity

Prolonged use in high humidity can lead to leakage in devices as well as printed circuit boards. If high humidity levels are anticipated, consider anti-humidity processing.

(2) Discharge of Static Electricity

When high-voltage charges exist close to semiconductor devices, discharges can cause abnormal operation. In such cases, use anti-static measures or processing to prevent discharges.

(3) Corrosive Gases, Dust, or Oil

Exposure to corrosive gases or contact with dust or oil may lead to chemical reactions that will adversely affect the device. If you use devices in such conditions, consider ways to prevent such exposure or to protect the devices.

(4) Radiation, Including Cosmic Radiation

Most devices are not designed for environments involving exposure to radiation or cosmic radiation. Users should provide shielding as appropriate.

(5) Smoke, Flame

CAUTION: Plastic molded devices are flammable, and therefore should not be used near combustible substances. If devices begin to smoke or burn, there is danger of the release of toxic gases. Customers considering the use of FUJITSU SEMICONDUCTOR products in other special environmental conditions should consult with sales representatives.

Please check the latest handling precautions at the following URL.
<http://edevice.fujitsu.com/fj/handling-e.pdf>

MB9B410T Series

■HANDLING DEVICES

- Power supply pins

In products with multiple VCC and VSS pins, respective pins at the same potential are interconnected within the device in order to prevent malfunctions such as latch-up. However, all of these pins should be connected externally to the power supply or ground lines in order to reduce electromagnetic emission levels, to prevent abnormal operation of strobe signals caused by the rise in the ground level, and to conform to the total output current rating.

Moreover, connect the current supply source with each Power supply pins and GND pins of this device at low impedance. It is also advisable that a ceramic capacitor of approximately 0.1 μF be connected as a bypass capacitor between each Power supply pins and GND pins near this device.

- Crystal oscillator circuit

Noise near the X0/X1 and X0A/X1A pins may cause the device to malfunction. Design the printed circuit board so that X0/X1, X0A/X1A pins, the crystal oscillator and the bypass capacitor to ground are located as close to the device as possible.

It is strongly recommended that the PC board artwork be designed such that the X0/X1 and X0A/X1A pins are surrounded by ground plane as this is expected to produce stable operation.

- Using an external clock

When using an external clock, the clock signal should be input to the X0,X0A pin only and the X1 and X1A pins should be kept open.

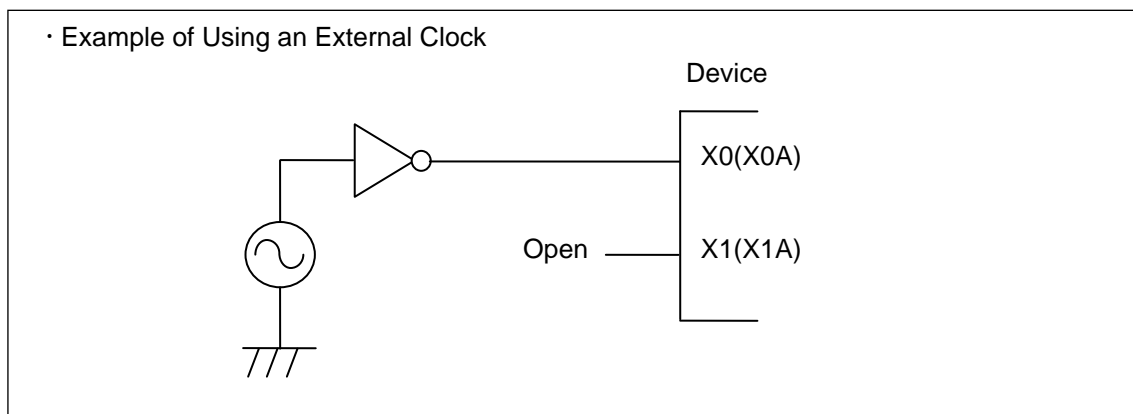

- Handling when using Multi-function serial pin as I²C pin

If it is using the multi-function serial pin as I²C pins, P-ch transistor of digital output is always disabled. However, I²C pins need to keep the electrical characteristic like other pins and not to connect to the external I²C bus system with power OFF.

- C Pin

This series contains the regulator. Be sure to connect a smoothing capacitor (C_S) for the regulator between the C pin and the GND pin. Please use a ceramic capacitor or a capacitor of equivalent frequency characteristics as a smoothing capacitor.

However, some laminated ceramic capacitors have the characteristics of capacitance variation due to thermal fluctuation (F characteristics and Y5V characteristics). Please select the capacitor that meets the specifications in the operating conditions to use by evaluating the temperature characteristics of a capacitor. A smoothing capacitor of about $4.7\mu\text{F}$ would be recommended for this series.

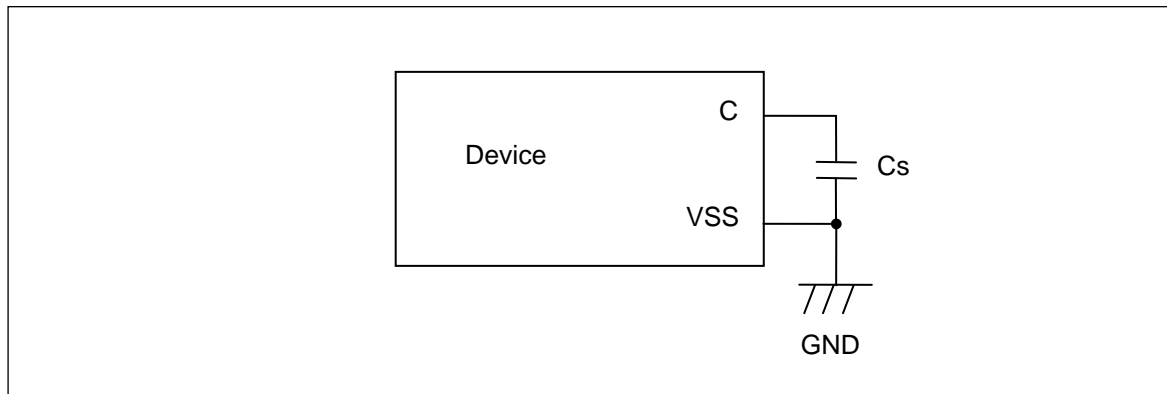

- Mode pins (MD0)

Connect the MD pin (MD0) directly to VCC or VSS pins. Design the printed circuit board such that the pull-up/down resistance stays low, as well as the distance between the mode pins and VCC pins or VSS pins is as short as possible and the connection impedance is low, when the pins are pulled-up/down such as for switching the pin level and rewriting the Flash memory data. It is because of preventing the device erroneously switching to test mode due to noise.

- Notes on power-on

Turn power on/off in the following order or at the same time.

If not using the A/D converter, connect $\text{AVCC} = \text{VCC}$ and $\text{AVSS} = \text{VSS}$.

Turning on : $\text{VCC} \rightarrow \text{AVCC} \rightarrow \text{AVRH}$

Turning off : $\text{AVRH} \rightarrow \text{AVCC} \rightarrow \text{VCC}$

MB9B410T Series

- **Serial Communication**

There is a possibility to receive wrong data due to the noise or other causes on the serial communication. Therefore, design a printed circuit board so as to avoid noise.

Consider the case of receiving wrong data due to noise, perform error detection such as by applying a checksum of data at the end. If an error is detected, retransmit the data.

- **Differences in features among the products with different memory sizes and between Flash products and MASK products**

The electric characteristics including power consumption, ESD, latch-up, noise characteristics, and oscillation characteristics among the products with different memory sizes and between Flash products and MASK products are different because chip layout and memory structures are different.

If you are switching to use a different product of the same series, please make sure to evaluate the electric characteristics.

- **Base Timer**

In the case of using ch.8 and ch.9 at I/O mode 1 (timer full mode), the TIOA09 pin cannot be used for external startup trigger input (TGIN).

Be sure to use the pin with making ESG1 and ESG2 bits of the Timer Control Register (Ch.9-TMCR) in the Base Timer to be "0b00" in order to disable trigger input.

■ BLOCK DIAGRAM

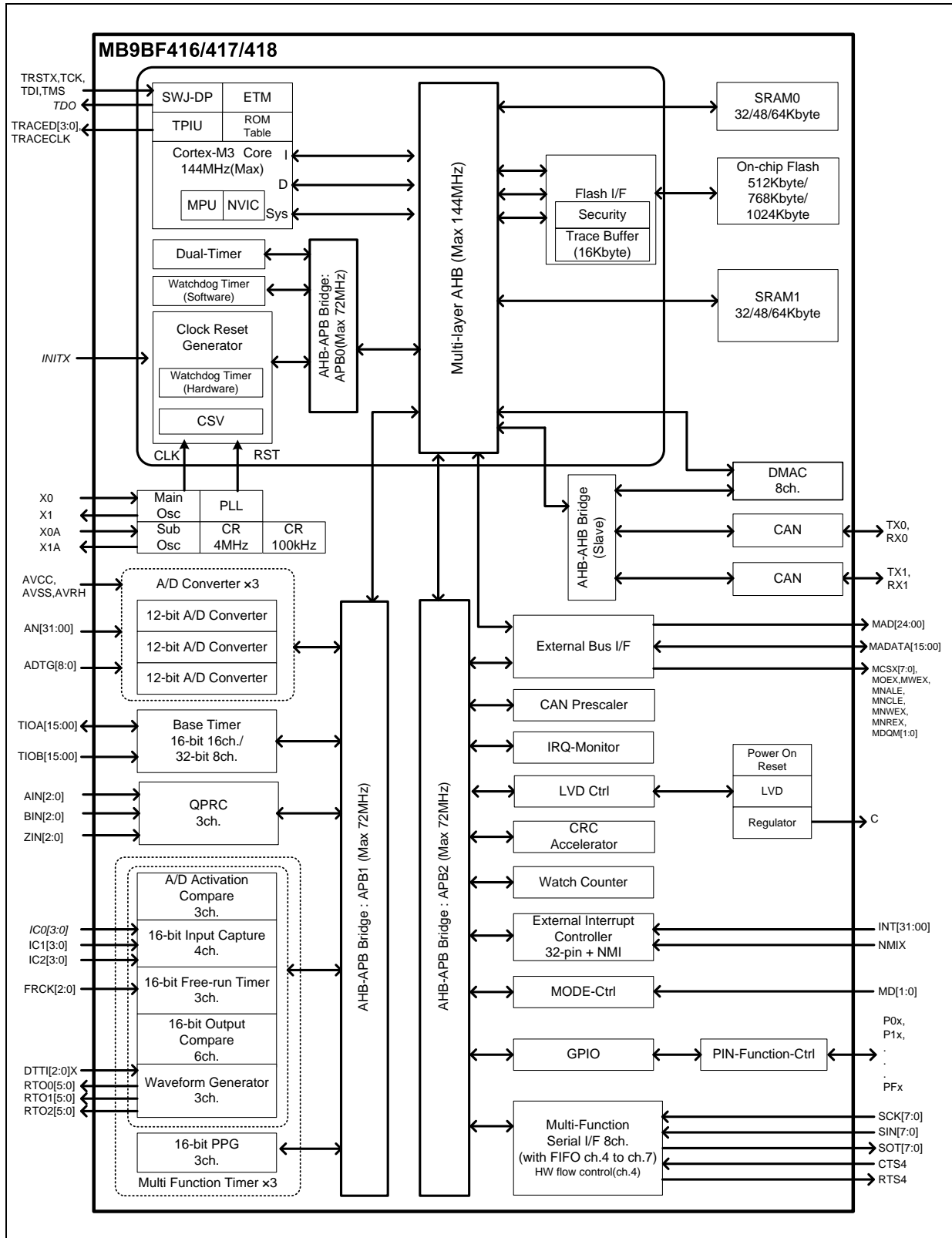

Note: The following items vary depending on the package.

- A) Number of external bus interface pin
- B) Number of 12-bit A/D converter channel

MB9B410T Series

■ MEMORY SIZE

See "●Memory size" in "■PRODUCT LINEUP" to confirm the memory size.

■ MEMORY MAP

•Memory Map(1)

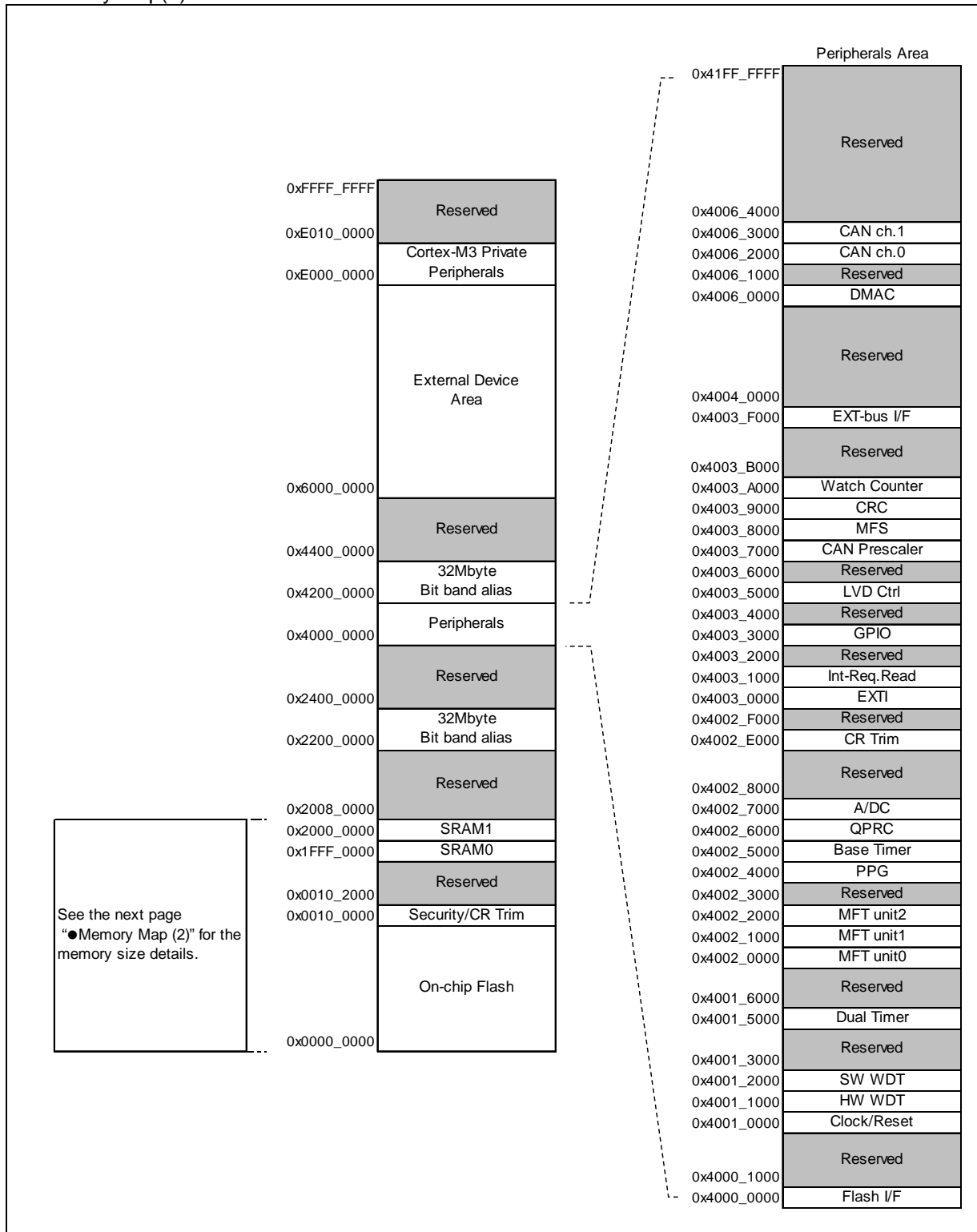

See the next page
 "•Memory Map (2)" for the
 memory size details.

MB9B410T Series

•Memory Map(2)

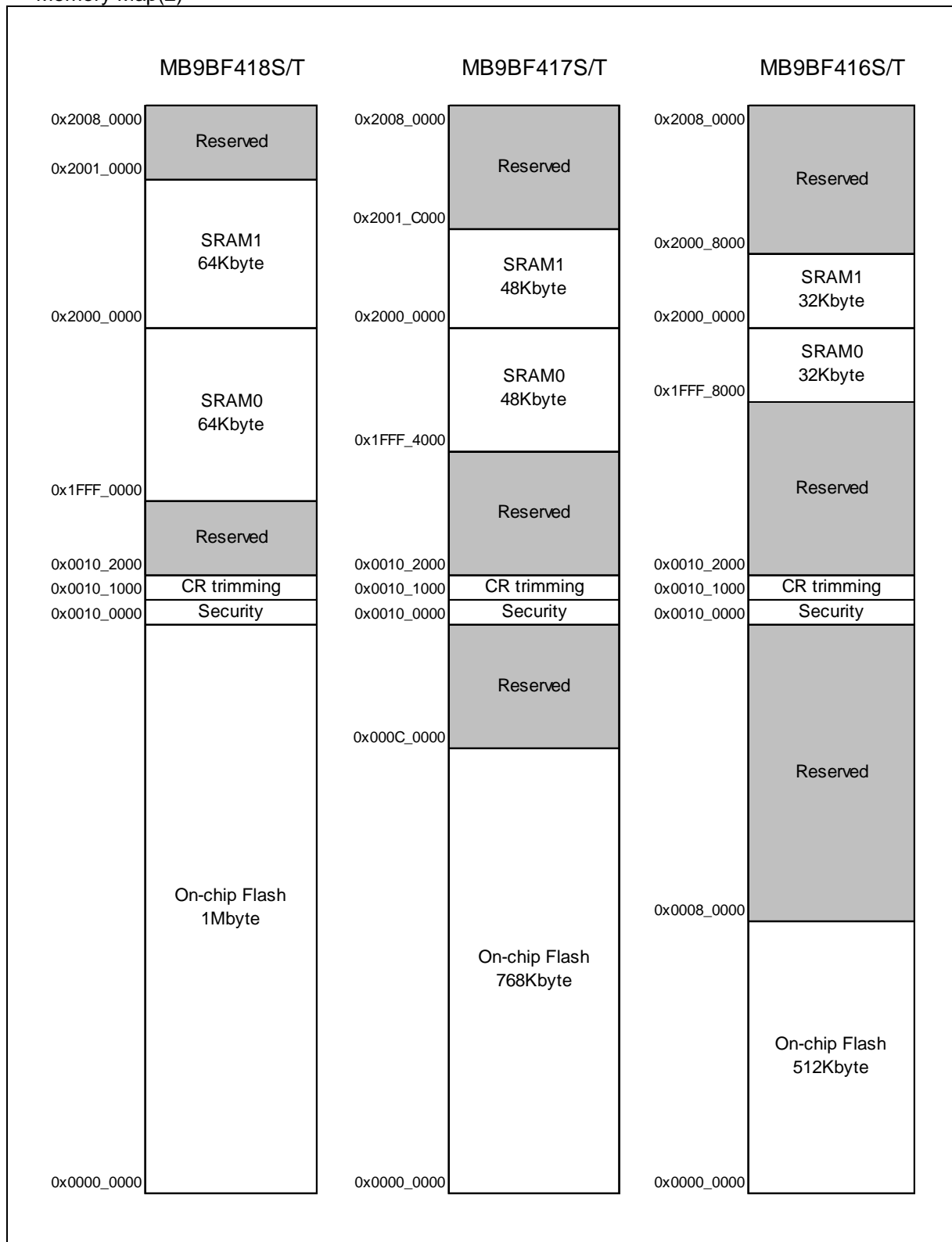

•Peripheral Address Map

Start address	End address	Bus	Peripherals
0x4000_0000	0x4000_0FFF	AHB	Flash I/F register
0x4000_1000	0x4000_FFFF		Reserved
0x4001_0000	0x4001_0FFF	APB0	Clock/Reset Control
0x4001_1000	0x4001_1FFF		Hardware Watchdog timer
0x4001_2000	0x4001_2FFF		Software Watchdog timer
0x4001_3000	0x4001_4FFF		Reserved
0x4001_5000	0x4001_5FFF		Dual-Timer
0x4001_6000	0x4001_FFFF		Reserved
0x4002_0000	0x4002_0FFF		APB1
0x4002_1000	0x4002_1FFF	Multi-function timer unit1	
0x4002_2000	0x4002_3FFF	Multi-function timer unit2	
0x4002_4000	0x4002_4FFF	PPG	
0x4002_5000	0x4002_5FFF	Base Timer	
0x4002_6000	0x4002_6FFF	Quadrature Position/Revolution Counter	
0x4002_7000	0x4002_7FFF	A/D Converter	
0x4002_8000	0x4002_DFFF	Reserved	
0x4002_E000	0x4002_EFFF	Internal CR trimming	
0x4002_F000	0x4002_FFFF	Reserved	
0x4003_0000	0x4003_0FFF	APB2	
0x4003_1000	0x4003_1FFF		Interrupt Request Batch-Read Function
0x4003_2000	0x4003_2FFF		Reserved
0x4003_3000	0x4003_3FFF		GPIO
0x4003_4000	0x4003_4FFF		Reserved
0x4003_5000	0x4003_5FFF		Low Voltage Detector
0x4003_6000	0x4003_6FFF		Reserved
0x4003_7000	0x4003_7FFF		CAN Prescaler
0x4003_8000	0x4003_8FFF		Multi-function serial Interface
0x4003_9000	0x4003_9FFF		CRC
0x4003_A000	0x4003_AFFF		Watch Counter
0x4003_B000	0x4003_EFFF		Reserved
0x4003_F000	0x4003_FFFF		External Memory interface
0x4004_0000	0x4005_FFFF		AHB
0x4006_0000	0x4006_0FFF	DMAC register	
0x4006_1000	0x4006_1FFF	Reserved	
0x4006_2000	0x4006_2FFF	CAN ch.0	
0x4006_3000	0x4006_3FFF	CAN ch.1	
0x4006_4000	0x41FF_FFFF	Reserved	

■ PIN STATUS IN EACH CPU STATE

The terms used for pin status have the following meanings.

- INITX=0
This is the period when the INITX pin is the "L" level.
- INITX=1
This is the period when the INITX pin is the "H" level.
- SPL=0
This is the status that the standby pin level setting bit (SPL) in the standby mode control register (STB_CTL) is set to "0".
- SPL=1
This is the status that the standby pin level setting bit (SPL) in the standby mode control register (STB_CTL) is set to "1".
- Input enabled
Indicates that the input function can be used.
- Internal input fixed at "0"
This is the status that the input function cannot be used. Internal input is fixed at "L".
- Hi-Z
Indicates that the pin drive transistor is disabled and the pin is put in the Hi-Z state.
- Setting disabled
Indicates that the setting is disabled.
- Maintain previous state
Maintains the state that was immediately prior to entering the current mode.
If a built-in peripheral function is operating, the output follows the peripheral function.
If the pin is being used as a port, that output is maintained.
- Analog input is enabled
Indicates that the analog input is enabled.
- Trace output
Indicates that the trace function can be used.

· List of Pin Status

Pin status type	Function group	Power-on reset or low-voltage detection state	INITX input state	Device internal reset state	Run mode or sleep mode state	Timer mode or stop mode state	
		Power supply unstable	Power supply stable		Power supply stable	Power supply stable	
		-	INITX=0	INITX=1	INITX=1	INITX=1	
		-	-	-	-	SPL=0	SPL=1
A	GPIO selected	Setting disabled	Setting disabled	Setting disabled	Maintain previous state	Maintain previous state	Hi-Z/ Internal input fixed at "0"
	Main crystal oscillator input pin	Input enabled	Input enabled	Input enabled	Input enabled	Input enabled	Input enabled
B	GPIO selected	Setting disabled	Setting disabled	Setting disabled	Maintain previous state	Maintain previous state	Hi-Z/ Internal input fixed at "0"
	Main crystal oscillator output pin	Hi-Z/ Internal input fixed at "0"/ or Input enable	Hi-Z/ Internal input fixed at "0"	Hi-Z/ Internal input fixed at "0"	Maintain previous state	Maintain previous state/ Hi-Z at oscillation stop* ¹ / Internal input fixed at "0"	Maintain previous state/ Hi-Z at oscillation stop* ¹ / Internal input fixed at "0"
C	INITX input pin	Pull-up/ Input enabled	Pull-up/ Input enabled	Pull-up/ Input enabled	Pull-up/ Input enabled	Pull-up/ Input enabled	Pull-up/ Input enabled
D	Mode input pin	Input enabled	Input enabled	Input enabled	Input enabled	Input enabled	Input enabled
E	JTAG selected	Hi-Z	Pull-up/ Input enabled	Pull-up/ Input enabled	Maintain previous state	Maintain previous state	Maintain previous state
	GPIO selected	Setting disabled	Setting disabled	Setting disabled			Hi-Z/ Internal input fixed at "0"
F	Trace selected	Setting disabled	Setting disabled	Setting disabled	Maintain previous state	Maintain previous state	Trace output
	External interrupt enabled selected						Maintain previous state
	GPIO selected, or resource other than above selected	Hi-Z	Hi-Z/ Input enabled	Hi-Z/ Input enabled			Hi-Z/ Internal input fixed at "0"

MB9B410T Series

Pin status type	Function group	Power-on reset or low-voltage detection state	INITX input state	Device internal reset state	Run mode or sleep mode state	Timer mode or stop mode state	
		Power supply unstable	Power supply stable		Power supply stable	Power supply stable	
		-	INITX=0	INITX=1	INITX=1	INITX=1	
		-	-	-	-	SPL=0	SPL=1
G	Trace selected	Setting disabled	Setting disabled	Setting disabled	Maintain previous state	Maintain previous state	Trace output
	GPIO selected, or resource other than above selected	Hi-Z	Hi-Z/ Input enabled	Hi-Z/ Input enabled	Maintain previous state	Maintain previous state	Hi-Z/ Internal input fixed at "0"
H	External interrupt enabled selected	Setting disabled	Setting disabled	Setting disabled	Maintain previous state	Maintain previous state	Maintain previous state
	GPIO selected, or resource other than above selected	Hi-Z	Hi-Z/ Input enabled	Hi-Z/ Input enabled	Maintain previous state	Maintain previous state	Hi-Z/ Internal input fixed at "0"
I	GPIO selected, resource selected	Hi-Z	Hi-Z/ Input enabled	Hi-Z/ Input enabled	Maintain previous state	Maintain previous state	Hi-Z/ Internal input fixed at "0"
J	NMIX selected	Setting disabled	Setting disabled	Setting disabled	Maintain previous state	Maintain previous state	Maintain previous state
	GPIO selected, or resource other than above selected	Hi-Z	Hi-Z/ Input enabled	Hi-Z/ Input enabled	Maintain previous state	Maintain previous state	Hi-Z/ Internal input fixed at "0"

MB9B410T Series

Pin status type	Function group	Power-on reset or low-voltage detection state	INITX input state	Device internal reset state	Run mode or sleep mode state	Timer mode or stop mode state	
		Power supply unstable	Power supply stable		Power supply stable	Power supply stable	
		-	INITX=0	INITX=1	INITX=1	INITX=1	
		-	-	-	-	SPL=0	SPL=1
K	Analog input selected	Hi-Z	Hi-Z/ Internal input fixed at "0"/ Analog input enabled	Hi-Z/ Internal input fixed at "0"/ Analog input enabled	Hi-Z/ Internal input fixed at "0"/ Analog input enabled	Hi-Z/ Internal input fixed at "0"/ Analog input enabled	Hi-Z/ Internal input fixed at "0"/ Analog input enabled
	GPIO selected, or resource other than above selected	Setting disabled	Setting disabled	Setting disabled	Maintain previous state	Maintain previous state	Hi-Z/ Internal input fixed at "0"
L	External interrupt enabled selected	Setting disabled	Setting disabled	Setting disabled	Maintain previous state	Maintain previous state	Maintain previous state
	Analog input selected	Hi-Z	Hi-Z/ Internal input fixed at "0"/ Analog input enabled	Hi-Z/ Internal input fixed at "0"/ Analog input enabled	Hi-Z/ Internal input fixed at "0"/ Analog input enabled	Hi-Z/ Internal input fixed at "0"/ Analog input enabled	Hi-Z/ Internal input fixed at "0"/ Analog input enabled
	GPIO selected, or resource other than above selected	Setting disabled	Setting disabled	Setting disabled	Maintain previous state	Maintain previous state	Hi-Z/ Internal input fixed at "0"
M	GPIO selected	Setting disabled	Setting disabled	Setting disabled	Maintain previous state	Maintain previous state	Hi-Z/ Internal input fixed at "0"
	Sub crystal oscillator input pin	Input enabled	Input enabled	Input enabled	Input enabled	Input enabled	Input enabled

MB9B410T Series

Pin status type	Function group	Power-on reset or low-voltage detection state	INITX input state	Device internal reset state	Run mode or sleep mode state	Timer mode or stop mode state	
		Power supply unstable	Power supply stable		Power supply stable	Power supply stable	
		-	INITX=0	INITX=1	INITX=1	INITX=1	
		-	-	-	-	SPL=0	SPL=1
N	GPIO selected	Setting disabled	Setting disabled	Setting disabled	Maintain previous state	Maintain previous state	Hi-Z/ Internal input fixed at "0"
	Sub crystal oscillator output pin	Hi-Z/ Internal input fixed at "0"/ or Input enable	Hi-Z/ Internal input fixed at "0"	Hi-Z/ Internal input fixed at "0"	Maintain previous state	Maintain previous state/ Hi-Z at oscillation stop*2/ Internal input fixed at "0"	Maintain previous state/ Hi-Z at oscillation stop*2/ Internal input fixed at "0"
O	GPIO selected	Hi-Z	Hi-Z/ Input enabled	Hi-Z/ Input enabled	Maintain previous state	Maintain previous state	Hi-Z/ Internal input fixed at "0"
P	Mode input pin	Input enabled	Input enabled	Input enabled	Input enabled	Input enabled	Input enabled
	GPIO selected	Setting disabled	Setting disabled	Setting disabled	Maintain previous state	Maintain previous state	Hi-Z/ Input enabled
Q	GPIO selected, resource selected	Hi-Z	Hi-Z/ Input enabled	Hi-Z/ Input enabled	Maintain previous state	Maintain previous state	Hi-Z/ Internal input fixed at "0"
R	External interrupt enabled selected	Setting disabled	Setting disabled	Setting disabled	Maintain previous state	Maintain previous state	Maintain previous state
	GPIO selected, or resource other than above selected	Hi-Z	Hi-Z/ Input enabled	Hi-Z/ Input enabled			Hi-Z/ Internal input fixed at "0"

*1: Oscillation is stopped at Sub timer mode, Low-speed CR timer mode, and STOP mode.

*2: Oscillation is stopped at STOP mode.

■ ELECTRICAL CHARACTERISTICS

1. Absolute Maximum Ratings

Parameter	Symbol	Rating		Unit	Remarks
		Min	Max		
Supply voltage* ^{1,*2}	V _{CC}	V _{SS} - 0.5	V _{SS} + 6.5	V	
Analog supply voltage* ^{1,*3}	AV _{CC}	V _{SS} - 0.5	V _{SS} + 6.5	V	
Analog reference voltage* ^{1,*3}	AV _{RH}	V _{SS} - 0.5	V _{SS} + 6.5	V	
Input voltage* ¹	V _I	V _{SS} - 0.5	V _{CC} + 0.5 (≤ 6.5V)	V	
		V _{SS} - 0.5	V _{SS} + 6.5	V	5V tolerant
Analog pin input voltage* ¹	V _{IA}	V _{SS} - 0.5	AV _{CC} + 0.5 (≤ 6.5V)	V	
Output voltage* ¹	V _O	V _{SS} - 0.5	V _{CC} + 0.5 (≤ 6.5V)	V	
"L" level maximum output current* ⁴	I _{OL}	-	10	mA	4mA type
			20	mA	8mA type
			20	mA	12mA type
"L" level average output current* ⁵	I _{OLAV}	-	4	mA	4mA type
			8	mA	8mA type
			12	mA	12mA type
"L" level total maximum output current	∑I _{OL}	-	100	mA	
"L" level total average output current* ⁶	∑I _{OLAV}	-	50	mA	
"H" level maximum output current* ⁴	I _{OH}	-	- 10	mA	4mA type
			- 20	mA	8mA type
			- 20	mA	12mA type
"H" level average output current* ⁵	I _{OHAV}	-	- 4	mA	4mA type
			- 8	mA	8mA type
			- 12	mA	12mA type
"H" level total maximum output current	∑I _{OH}	-	- 100	mA	
"H" level total average output current* ⁶	∑I _{OHAV}	-	- 50	mA	
Power consumption	P _D	-	1000	mW	
Storage temperature	T _{STG}	- 55	+ 150	°C	

*1: These parameters are based on the condition that V_{SS} = AV_{SS} = 0.0 V.

*2: V_{CC} must not drop below V_{SS} - 0.5V.

*3: Ensure that the voltage does not exceed V_{CC} + 0.5 V, for example, when the power is turned on.

*4: The maximum output current is defined as the value of the peak current flowing through any one of the corresponding pins.

*5: The average output current is defined as the average current value flowing through any one of the corresponding pins for a 100 ms period.

*6: The total average output current is defined as the average current value flowing through all of corresponding pins for a 100 ms.

<WARNING>

Semiconductor devices can be permanently damaged by application of stress (voltage, current, temperature, etc.) in excess of absolute maximum ratings. Do not exceed these ratings.

MB9B410T Series

2. Recommended Operating Conditions

(V_{ss} = AV_{ss} = 0.0V)

Parameter	Symbol	Conditions	Value		Unit	Remarks
			Min	Max		
Power supply voltage	V _{cc}	-	2.7	5.5	V	
Analog supply voltage	AV _{cc}	-	2.7	5.5	V	AV _{cc} = V _{cc}
Analog reference voltage	AV _{RH}	-	2.7	AV _{cc}	V	
Smoothing capacitor	C _s	-	1	10	μF	For Regulator *
Operating temperature	FPT-144P-M08 FPT-176P-M07 BGA-192P-M06	T _a	When mounted on four-layer PCB - 40	+ 85	°C	

*: See "●C pin" in "■HANDLING DEVICES" for the connection of the smoothing capacitor.

<WARNING>

The recommended operating conditions are required in order to ensure the normal operation of the semiconductor device. All of the device's electrical characteristics are warranted when the device is operated within these ranges.

Always use semiconductor devices within their recommended operating condition ranges. Operation outside these ranges may adversely affect reliability and could result in device failure. No warranty is made with respect to uses, operating conditions, or combinations not represented on the data sheet. Users considering application outside the listed conditions are advised to contact their representatives beforehand.

MB9B410T Series

3. DC Characteristics

(1) Current Rating

(V_{cc} = AV_{cc} = 2.7V to 5.5V, V_{ss} = AV_{ss} = 0V, T_a = - 40°C to + 85°C)

Parameter	Symbol	Pin name	Conditions	Value			Unit	Remarks
				Min	Typ	Max		
Power supply current	I _{cc}	V _{cc}	Normal operation (PLL)	-	100	180	mA	CPU : 144MHz, Peripheral : 72MHz, Flash memory 2Wait TraceBuffer : ON FRWTR.RWT = 10 FSYNDN.SD = 000 FBFCR.BE = 1 *1
				-	65	135	mA	CPU : 72MHz, Peripheral : 72MHz, Flash memory 0Wait TraceBuffer : OFF FRWTR.RWT = 00 FSYNDN.SD = 000 FBFCR.BE = 0 *1
			Normal operation (built-in high-speed CR)	-	6	57.8	mA	CPU/ Peripheral : 4MHz* ² Flash memory 0Wait FRWTR.RWT = 00 FSYNDN.SD = 000 *1
			Normal operation (sub oscillation)	-	1.3	51.7	mA	CPU/ Peripheral : 32kHz Flash memory 0Wait FRWTR.RWT = 00 FSYNDN.SD = 000 *1
			Normal operation (built-in low-speed CR)	-	1.3	51.7	mA	CPU/ Peripheral : 100kHz Flash memory 0Wait FRWTR.RWT = 00 FSYNDN.SD = 000* ¹
			SLEEP operation (PLL)	-	30	89	mA	Peripheral : 72MHz *1
	I _{ccs}	V _{cc}	SLEEP operation (built-in high-speed CR)	-	4.5	55.9	mA	Peripheral : 4MHz *1, *2
			SLEEP operation (sub oscillation)	-	1.2	51.6	mA	Peripheral : 32kHz *1
			SLEEP operation (built-in low-speed CR)	-	1.2	51.6	mA	Peripheral : 100kHz *1

MB9B410T Series

Parameter	Symbol	Pin name	Conditions	Value			Unit	Remarks
				Min	Typ	Max		
Power supply current	I _{CCH}	V _{CC}	STOP mode	-	1	5	mA	Ta = + 25°C, When LVD is off *1
				-	-	50	mA	Ta = + 85°C, When LVD is off *1
	I _{CCT}		TIMER mode (sub oscillation)	-	1.1	5	mA	Ta = + 25°C, When LVD is off *1
				-	-	50	mA	Ta = + 85°C, When LVD is off *1
Low-voltage detection circuit (LVD) power supply current	I _{CLVD}	At operation	-	4	7	μA	For occurrence of interrupt	

*1: When all ports are fixed.

*2: When setting it to 4MHz by trimming.

MB9B410T Series

(2) Pin Characteristics

($V_{CC} = AV_{CC} = 2.7V$ to $5.5V$, $V_{SS} = AV_{SS} = 0V$, $T_a = -40^{\circ}C$ to $+85^{\circ}C$)

Parameter	Symbol	Pin name	Conditions	Value			Unit	Remarks
				Min	Typ	Max		
"H" level input voltage (hysteresis input)	V_{IHS}	CMOS hysteresis input pin, MD0, MD1	-	$V_{CC} \times 0.8$	-	$V_{CC} + 0.3$	V	
		5V tolerant input pin	-	$V_{CC} \times 0.8$	-	$V_{SS} + 5.5$	V	
		TTL Schmitt input pin	-	2.0	-	$V_{CC} + 0.3$	V	
"L" level input voltage (hysteresis input)	V_{ILS}	CMOS hysteresis input pin, MD0, MD1	-	$V_{SS} - 0.3$	-	$V_{CC} \times 0.2$	V	
		5V tolerant input pin	-	$V_{SS} - 0.3$	-	$V_{CC} \times 0.2$	V	
		TTL Schmitt input pin	-	$V_{SS} - 0.3$	-	0.8	V	
"H" level output voltage	V_{OH}	4mA type	$V_{CC} \geq 4.5V$ $I_{OH} = -4mA$	$V_{CC} - 0.5$	-	V_{CC}	V	
			$V_{CC} < 4.5V$ $I_{OH} = -2mA$					
		8mA type	$V_{CC} \geq 4.5V$ $I_{OH} = -8mA$	$V_{CC} - 0.5$	-	V_{CC}	V	
			$V_{CC} < 4.5V$ $I_{OH} = -4mA$					
		12mA type	$V_{CC} \geq 4.5V$ $I_{OH} = -12mA$	$V_{CC} - 0.5$	-	V_{CC}	V	
			$V_{CC} < 4.5V$ $I_{OH} = -8mA$					

MB9B410T Series

Parameter	Symbol	Pin name	Conditions	Value			Unit	Remarks
				Min	Typ	Max		
"L" level output voltage	V_{OL}	4mA type	$V_{CC} \geq 4.5 \text{ V}$ $I_{OL} = 4\text{mA}$	V_{SS}	-	0.4	V	
			$V_{CC} < 4.5 \text{ V}$ $I_{OL} = 2\text{mA}$					
		8mA type	$V_{CC} \geq 4.5 \text{ V}$ $I_{OL} = 8\text{mA}$	V_{SS}	-	0.4	V	
			$V_{CC} < 4.5 \text{ V}$ $I_{OL} = 4\text{mA}$					
		12mA type	$V_{CC} \geq 4.5 \text{ V}$ $I_{OL} = 12\text{mA}$	V_{SS}	-	0.4	V	
			$V_{CC} < 4.5 \text{ V}$ $I_{OL} = 8\text{mA}$					
Input leak current	I_{IL}	-	-	-5	-	+5	μA	
Pull-up resistance	R_{PU}	Pull-up pin	$V_{CC} \geq 4.5 \text{ V}$	25	50	100	k Ω	
			$V_{CC} < 4.5 \text{ V}$	30	80	200		
Input capacitance	C_{IN}	Other than V_{CC} , V_{SS} , AV_{CC} , AV_{SS} , AV_{RH}	-	-	5	15	pF	

4. AC Characteristics

(1) Main Clock Input Characteristics

(V_{CC} = 2.7V to 5.5V, V_{SS} = 0V, T_a = - 40°C to + 85°C)

Parameter	Symbol	Pin name	Conditions	Value		Unit	Remarks	
				Min	Max			
Input frequency	F _{CH}	X0, X1	V _{CC} ≥ 4.5V	4	48	MHz	When crystal oscillator is connected	
			V _{CC} < 4.5V	4	20			
			V _{CC} ≥ 4.5V	4	48	MHz		
			V _{CC} < 4.5V	4	20			
Input clock cycle	t _{CY LH}		V _{CC} ≥ 4.5V	20.83	250	ns	When using external clock	
			V _{CC} < 4.5V	50	250			
Input clock pulse width	-			P _{WH} /t _{CY LH} , P _{WL} /t _{CY LH}	45	55	%	When using external clock
Input clock rising time and falling time	t _{CF} , t _{CR}			-	-	5	ns	When using external clock
Internal operating clock ^{*1} frequency	F _{CM}	-	-	-	144	MHz	Master Clock	
	F _{CC}	-	-	-	144	MHz	Base clock (HCLK/FCLK)	
	F _{CP0}	-	-	-	72	MHz	APB0 bus clock ^{*2}	
	F _{CP1}	-	-	-	72	MHz	APB1 bus clock ^{*2}	
	F _{CP2}	-	-	-	72	MHz	APB2 bus clock ^{*2}	
Internal operating clock ^{*1} cycle time	t _{CY CC}	-	-	6.94	-	ns	Base clock (HCLK/FCLK)	
	t _{CY CP0}	-	-	13.8	-	ns	APB0 bus clock ^{*2}	
	t _{CY CP1}	-	-	13.8	-	ns	APB1 bus clock ^{*2}	
	t _{CY CP2}	-	-	13.8	-	ns	APB2 bus clock ^{*2}	

*1: For more information about each internal operating clock, see "Chapter:Clock" in "FM3 Family PERIPHERAL MANUAL".

*2: For about each APB bus which each peripheral is connected to, see "BLOCK DIAGRAM" in this data sheet.

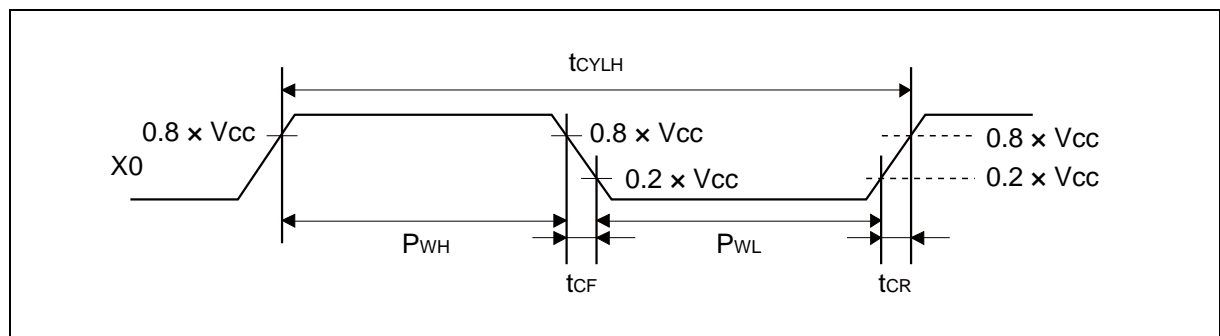

MB9B410T Series

(2) Sub Clock Input Characteristics

(Vcc = 2.7V to 5.5V, Vss = 0V, Ta = -40°C to +85°C)

Parameter	Symbol	Pin name	Conditions	Value			Unit	Remarks
				Min	Typ	Max		
Input frequency	1/ t _{CYLL}	X0A, X1A	-	-	32.768	-	kHz	When crystal oscillator is connected
			-	32	-	100		kHz
Input clock cycle	t _{CYLL}		-	10	-	31.25	μs	When using external clock
Input clock pulse width	-		P _{WH} /t _{CYLL} , P _{WL} /t _{CYLL}	45	-	55	%	When using external clock

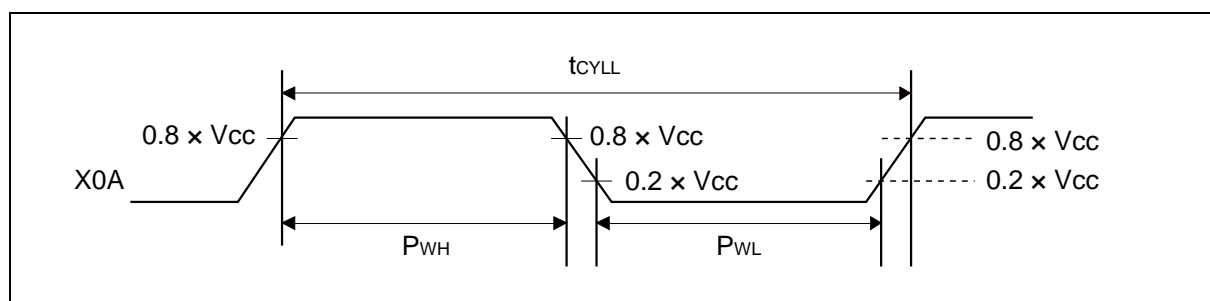

(3) Built-in CR Oscillation Characteristics

- Built-in High-speed CR

(Vcc = 2.7V to 5.5V, Vss = 0V, Ta = -40°C to +85°C)

Parameter	Symbol	Conditions	Value			Unit	Remarks
			Min	Typ	Max		
Clock frequency	F _{CRH}	Ta = +25°C	3.96	4	4.04	MHz	When trimming*
		Ta = 0°C to +70°C	3.84	4	4.16		
		Ta = -40°C to +85°C	3.8	4	4.2		
		Ta = -40°C to +85°C	3	4	5		When not trimming

*: In the case of using the values in the CR trimming area of Flash memory at shipment for frequency trimming.

- Built-in Low-speed CR

(Vcc = 2.7V to 5.5V, Vss = 0V, Ta = -40°C to +85°C)

Parameter	Symbol	Conditions	Value			Unit	Remarks
			Min	Typ	Max		
Clock frequency	F _{CRL}	-	50	100	150	kHz	

(4-1) Operating Conditions of Main PLL (In the case of using main clock for input of PLL)

(V_{CC} = 2.7V to 5.5V, V_{SS} = 0V, T_a = - 40°C to + 85°C)

Parameter	Symbol	Value			Unit	Remarks
		Min	Typ	Max		
PLL oscillation stabilization wait time* ¹ (LOCK UP time)	t _{LOCK}	100	-	-	μs	
PLL input clock frequency	f _{PLLI}	4	-	16	MHz	
PLL multiplication rate	-	13	-	75	multiplier	
PLL macro oscillation clock frequency	f _{PLLO}	200	-	300	MHz	
Main PLL clock frequency* ²	F _{CLKPLL}	-	-	144	MHz	

*1: Time from when the PLL starts operating until the oscillation stabilizes.

*2: For more information about Main PLL clock (CLKPLL), see "Chapter: Clock" in "FM3 Family PERIPHERAL MANUAL".

(4-2) Operating Conditions of Main PLL (In the case of using built-in high-speed CR clock for the input clock of the main PLL)

(V_{CC} = 2.7V to 5.5V, V_{SS} = 0V, T_a = - 40°C to + 85°C)

Parameter	Symbol	Value			Unit	Remarks
		Min	Typ	Max		
PLL oscillation stabilization wait time* ¹ (LOCK UP time)	t _{LOCK}	100	-	-	μs	
PLL input clock frequency	f _{PLLI}	3.8	4	4.2	MHz	
PLL multiplication rate	-	50	-	71	multiplier	
PLL macro oscillation clock frequency	f _{PLLO}	190	-	300	MHz	
Main PLL clock frequency* ²	F _{CLKPLL}	-	-	144	MHz	

*1: Time from when the PLL starts operating until the oscillation stabilizes.

*2: For more information about Main PLL clock (CLKPLL), see "Chapter: Clock" in "FM3 Family PERIPHERAL MANUAL".

Note: Make sure to input the built-in high-speed CR clock that has been trimmed.

MB9B410T Series

(5) Reset Input Characteristics

($V_{CC} = 2.7V$ to $5.5V$, $V_{SS} = 0V$, $T_a = -40^{\circ}C$ to $+85^{\circ}C$)

Parameter	Symbol	Pin name	Conditions	Value		Unit	Remarks
				Min	Max		
Reset input time	t_{INITX}	INITX	-	500	-	ns	

(6) Power-on Reset Timing

($V_{CC} = 2.7V$ to $5.5V$, $V_{SS} = 0V$, $T_a = -40^{\circ}C$ to $+85^{\circ}C$)

Parameter	Symbol	Pin name	Value		Unit	Remarks
			Min	Max		
Power supply rising time	T_r	V_{CC}	0	-	ms	
Power supply shut down time	T_{off}		1	-	ms	

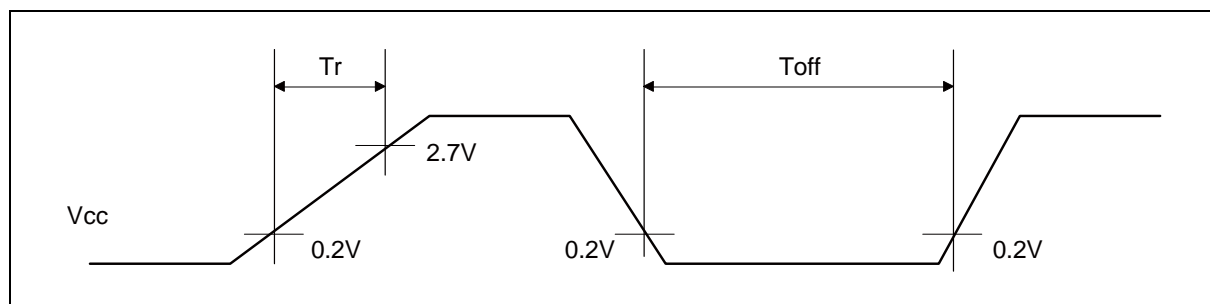

(7) External Bus Timing

- External bus clock output characteristics

($V_{CC} = 2.7V$ to $5.5V$, $V_{SS} = 0V$, $T_a = -40^{\circ}C$ to $+85^{\circ}C$)

Parameter	Symbol	Pin name	Conditions	Value		Unit
				Min	Max	
Output frequency	t_{CYCLE}	MCLKOUT*1	$V_{CC} \geq 4.5V$	-	50^{*2}	MHz
			$V_{CC} < 4.5V$	-	32^{*3}	MHz

*1: The external bus clock output (MCLKOUT) is the divided clock of HCLK.

For more information about setting of clock divider, see "Chapter: External Bus Interface" in "FM3 Family PERIPHERAL MANUAL".

*2: When the AHB bus clock frequency is more than 100MHz, the divider setting for MCLKOUT must be more than 4.

*3: When the AHB bus clock frequency is more than 64MHz, the divider setting for MCLKOUT must be more than 4.

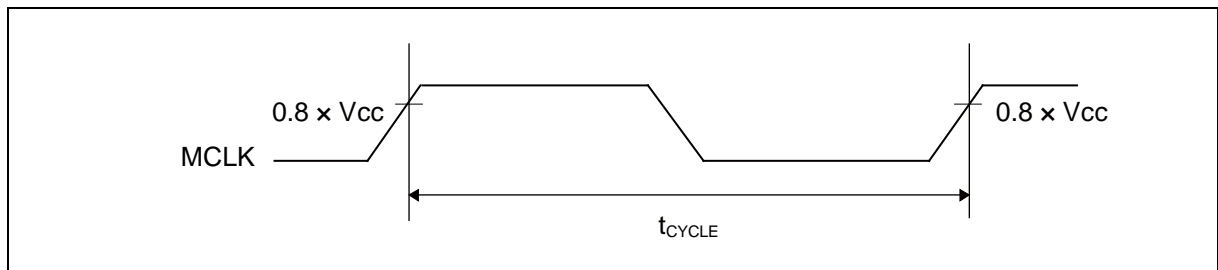

- External bus signal input/output characteristics

($V_{CC} = 2.7V$ to $5.5V$, $V_{SS} = 0V$, $T_a = -40^{\circ}C$ to $+85^{\circ}C$)

Parameter	Symbol	Conditions	Value	Unit	Remarks
Signal input characteristics	V_{IH}	-	$0.8 \times V_{CC}$	V	
	V_{IL}		$0.2 \times V_{CC}$	V	
Signal output characteristics	V_{OH}		$0.8 \times V_{CC}$	V	
	V_{OL}		$0.2 \times V_{CC}$	V	

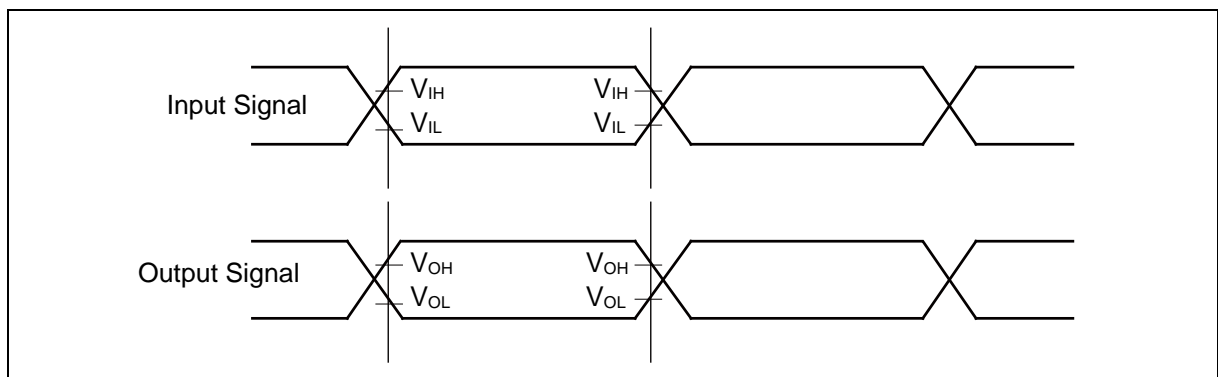

MB9B410T Series

• Separate Bus Access Asynchronous SRAM Mode

($V_{CC} = 2.7V$ to $5.5V$, $V_{SS} = 0V$, $T_a = -40^{\circ}C$ to $+85^{\circ}C$)

Parameter	Symbol	Pin name	Conditions	Value		Unit
				Min	Max	
MOEX Min pulse width	$t_{OE\bar{W}}$	MOEX	$V_{CC} \geq 4.5V$	MCLK \times n-3	-	ns
			$V_{CC} < 4.5V$			
MCSX $\downarrow \rightarrow$ Address output delay time	t_{CSL-AV}	MCSX[7:0], MAD[24:0]	$V_{CC} \geq 4.5V$	-9	+9	ns
			$V_{CC} < 4.5V$	-12	+12	
MOEX $\uparrow \rightarrow$ Address hold time	$t_{OE\bar{H}-AX}$	MOEX, MAD[24:0]	$V_{CC} \geq 4.5V$	0	MCLK \times m+9	ns
			$V_{CC} < 4.5V$		MCLK \times m+12	
MCSX $\downarrow \rightarrow$ MOEX \downarrow delay time	$t_{CSL-OEL}$	MOEX, MCSX[7:0]	$V_{CC} \geq 4.5V$	MCLK \times m-9	MCLK \times m+9	ns
			$V_{CC} < 4.5V$	MCLK \times m-12	MCLK \times m+12	
MOEX $\uparrow \rightarrow$ MCSX \uparrow time	$t_{OE\bar{H}-CSH}$	MOEX, MCSX[7:0]	$V_{CC} \geq 4.5V$	0	MCLK \times m+9	ns
			$V_{CC} < 4.5V$		MCLK \times m+12	
MCSX $\downarrow \rightarrow$ MDQM \downarrow delay time	$t_{CSL-RDQML}$	MCSX, MDQM[1:0]	$V_{CC} \geq 4.5V$	MCLK \times m-9	MCLK \times m+9	ns
			$V_{CC} < 4.5V$	MCLK \times m-12	MCLK \times m+12	
Data set up \rightarrow MOEX \uparrow time	t_{DS-OE}	MOEX, MADATA[15:0]	$V_{CC} \geq 4.5V$	20	-	ns
			$V_{CC} < 4.5V$	38	-	
MOEX $\uparrow \rightarrow$ Data hold time	t_{DH-OE}	MOEX, MADATA[15:0]	$V_{CC} \geq 4.5V$	0	-	ns
			$V_{CC} < 4.5V$			
MWEX Min pulse width	$t_{WE\bar{W}}$	MWEX	$V_{CC} \geq 4.5V$	MCLK \times n-3	-	ns
			$V_{CC} < 4.5V$			
MWEX $\uparrow \rightarrow$ Address output delay time	$t_{WE\bar{H}-AX}$	MWEX, MAD[24:0]	$V_{CC} \geq 4.5V$	0	MCLK \times m+9	ns
			$V_{CC} < 4.5V$		MCLK \times m+12	
MCSX $\downarrow \rightarrow$ MWEX \downarrow delay time	$t_{CSL-WEL}$	MWEX, MCSX[7:0]	$V_{CC} \geq 4.5V$	MCLK \times n-9	MCLK \times n+9	ns
			$V_{CC} < 4.5V$	MCLK \times n-12	MCLK \times n+12	
MWEX $\uparrow \rightarrow$ MCSX \uparrow delay time	$t_{WE\bar{H}-CSH}$	MWEX, MCSX[7:0]	$V_{CC} \geq 4.5V$	0	MCLK \times m+9	ns
			$V_{CC} < 4.5V$		MCLK \times m+12	
MCSX $\downarrow \rightarrow$ MDQM \downarrow delay time	$t_{CSL-WDQML}$	MCSX, MDQM[1:0]	$V_{CC} \geq 4.5V$	MCLK \times n-9	MCLK \times n+9	ns
			$V_{CC} < 4.5V$	MCLK \times n-12	MCLK \times n+12	
MWEX $\downarrow \rightarrow$ Data output time	t_{WEL-DV}	MWEX, MADATA[15:0]	$V_{CC} \geq 4.5V$	-9	+9	ns
			$V_{CC} < 4.5V$	-12	+12	
MWEX $\uparrow \rightarrow$ Data hold time	$t_{WE\bar{H}-DX}$	MWEX, MADATA[15:0]	$V_{CC} \geq 4.5V$	0	MCLK \times m+9	ns
			$V_{CC} < 4.5V$		MCLK \times m+12	

Note: When the external load capacitance $C_L = 30pF$. (m = 0 to 15, n = 1 to 16)

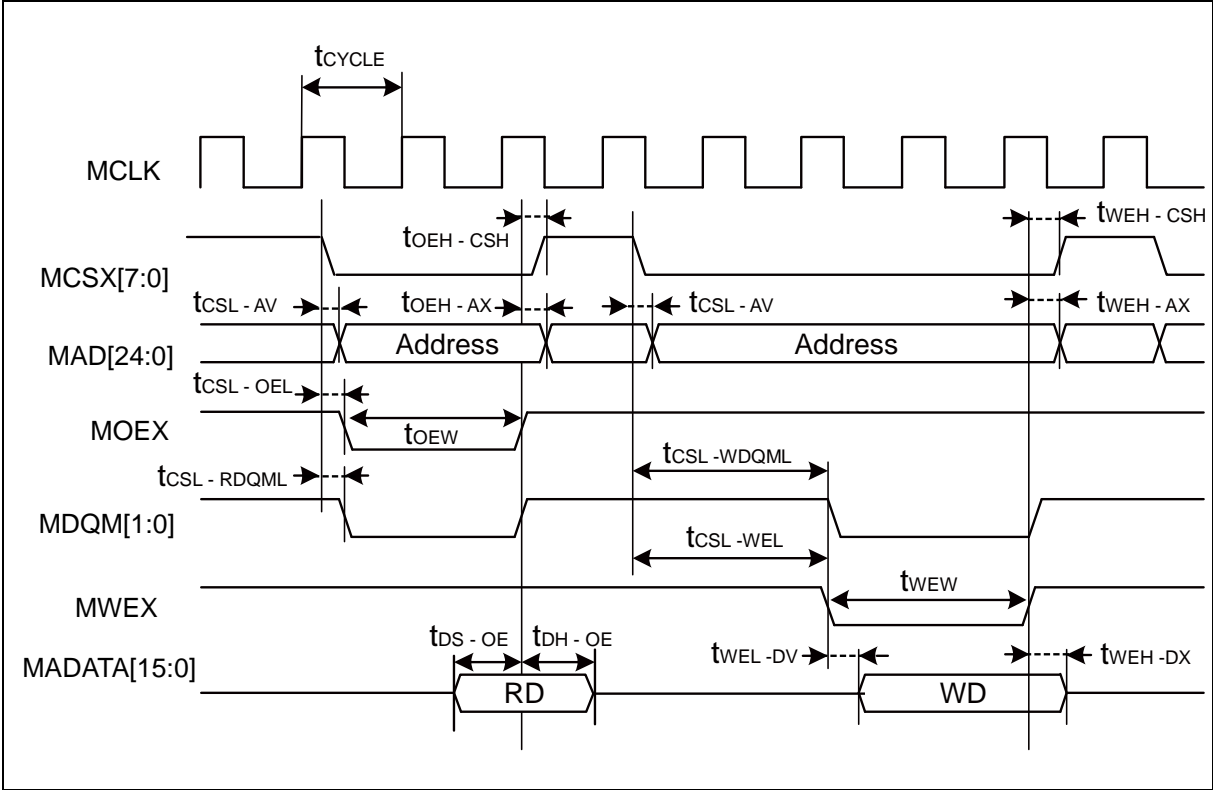

MB9B410T Series

• Separate Bus Access Synchronous SRAM Mode

($V_{CC} = 2.7V$ to $5.5V$, $V_{SS} = 0V$, $T_a = -40^{\circ}C$ to $+85^{\circ}C$)

Parameter	Symbol	Pin name	Conditions	Value		Unit
				Min	Max	
Address delay time	t_{AV}	MCLK, MAD[24:0]	$V_{CC} \geq 4.5V$	1	9	ns
			$V_{CC} < 4.5V$		12	
MCSX delay time	t_{CSL}	MCLK, MCSX[7:0]	$V_{CC} \geq 4.5V$	1	9	ns
			$V_{CC} < 4.5V$			
	t_{CSH}		$V_{CC} \geq 4.5V$	1	9	ns
			$V_{CC} < 4.5V$			
MOEX delay time	t_{REL}	MCLK, MOEX	$V_{CC} \geq 4.5V$	1	9	ns
			$V_{CC} < 4.5V$			
	t_{REH}		$V_{CC} \geq 4.5V$	1	9	ns
			$V_{CC} < 4.5V$			
Data set up → MCLK ↑ time	t_{DS}	MCLK, MADATA[15:0]	$V_{CC} \geq 4.5V$	19	-	ns
			$V_{CC} < 4.5V$	37		
MCLK ↑ → Data hold time	t_{DH}	MCLK, MADATA[15:0]	$V_{CC} \geq 4.5V$	0	-	ns
			$V_{CC} < 4.5V$			
MWEX delay time	t_{WEL}	MCLK, MWEX	$V_{CC} \geq 4.5V$	1	9	ns
			$V_{CC} < 4.5V$			
	t_{WEH}		$V_{CC} \geq 4.5V$	1	9	ns
			$V_{CC} < 4.5V$			
MDQM[1:0] delay time	t_{DQML}	MCLK, MDQM[1:0]	$V_{CC} \geq 4.5V$	1	9	ns
			$V_{CC} < 4.5V$			
	t_{DQMH}		$V_{CC} \geq 4.5V$	1	9	ns
			$V_{CC} < 4.5V$			
MCLK ↑ → Data output time	t_{OD}	MCLK, MADATA[15:0]	$V_{CC} \geq 4.5V$	1	18	ns
			$V_{CC} < 4.5V$		24	

Note: When the external load capacitance $C_L = 30pF$.

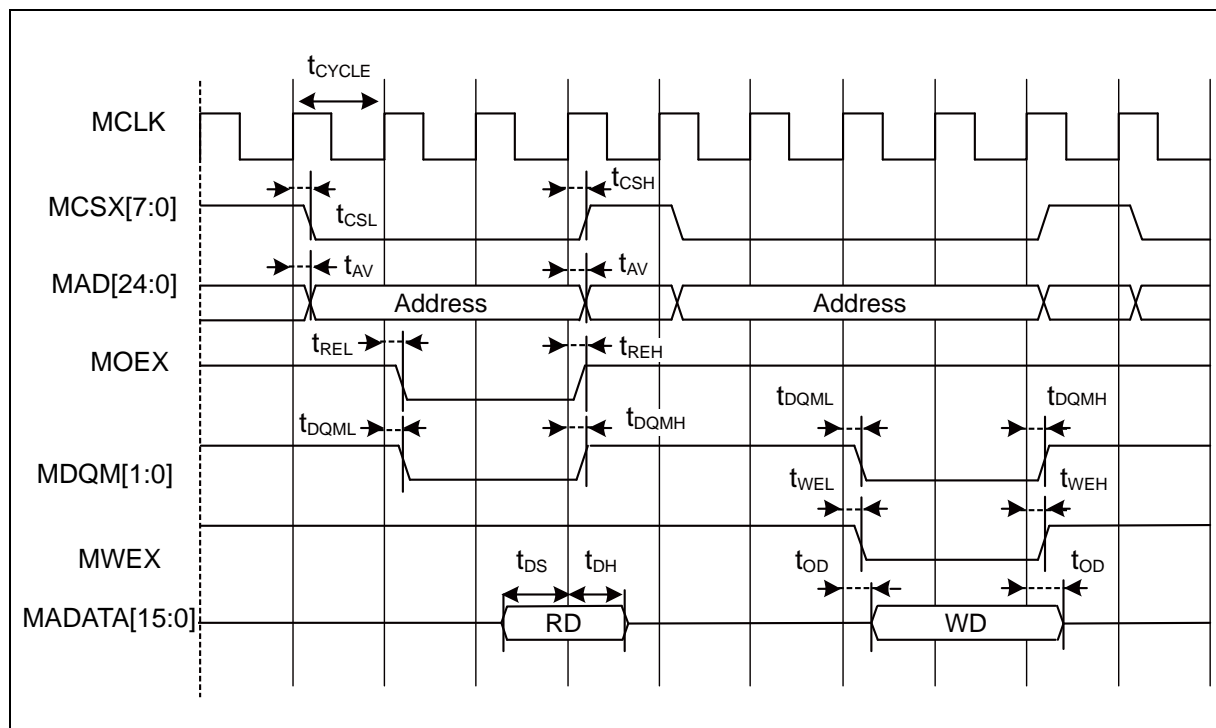

MB9B410T Series

• Multiplexed Bus Access Asynchronous SRAM Mode

($V_{CC} = 2.7V$ to $5.5V$, $V_{SS} = 0V$, $T_a = -40^{\circ}C$ to $+85^{\circ}C$)

Parameter	Symbol	Pin name	Conditions	Value		Unit
				Min	Max	
Multiplexed address delay time	$t_{ALE-CHMADV}$	MALE, MADATA[15:0]	$V_{CC} \geq 4.5V$	0	10	ns
			$V_{CC} < 4.5V$		20	
Multiplexed address hold time	t_{CHMADH}	MALE, MADATA[15:0]	$V_{CC} \geq 4.5V$	$MCLK \times n + 0$	$MCLK \times n + 10$	ns
			$V_{CC} < 4.5V$	$MCLK \times n + 0$	$MCLK \times n + 20$	

Note: When the external load capacitance $C_L = 30pF$. ($m = 0$ to 15 , $n = 1$ to 16)

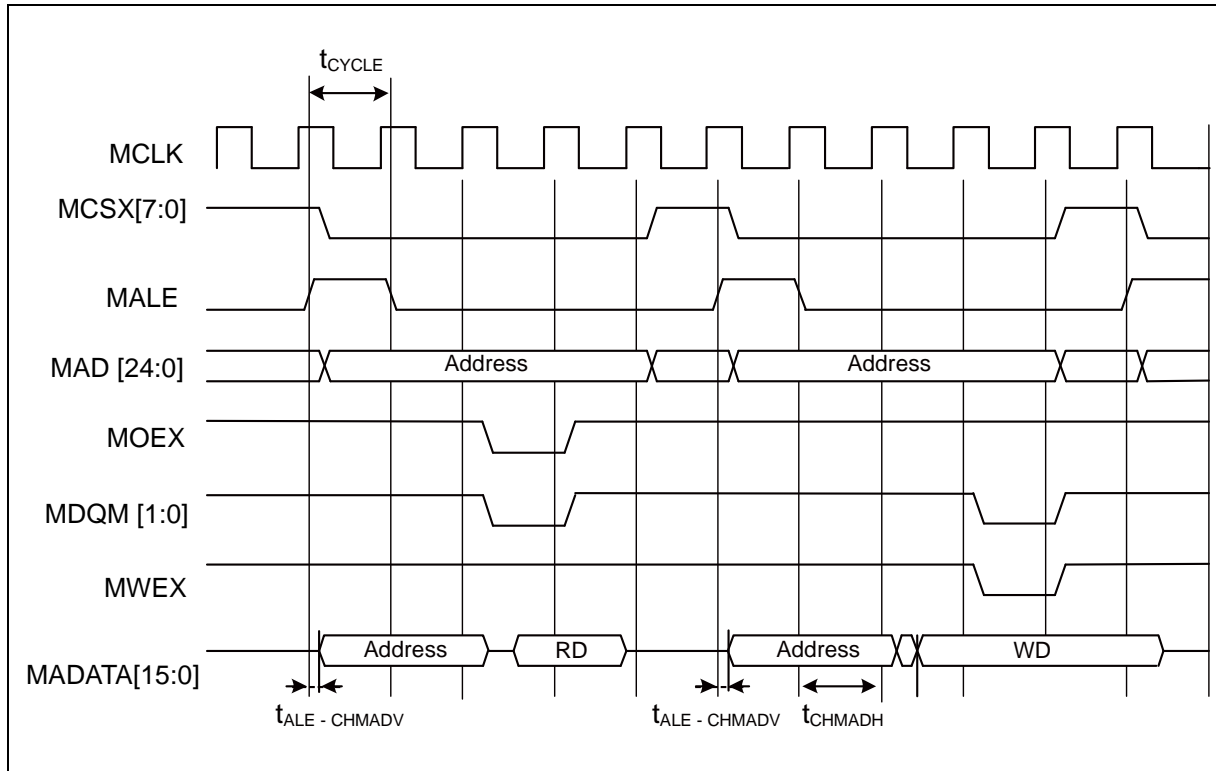

MB9B410T Series

• Multiplexed Bus Access Synchronous SRAM Mode

($V_{CC} = 2.7V$ to $5.5V$, $V_{SS} = 0V$, $T_a = -40^{\circ}C$ to $+85^{\circ}C$)

Parameter	Symbol	Pin name	Conditions	Value		Unit	Remarks
				Min	Max		
MALE delay time	t_{CHAL}	MCLK, MALE	$V_{CC} \geq 4.5V$	1	9	ns	
			$V_{CC} < 4.5V$		12		
	t_{CHAH}		$V_{CC} \geq 4.5V$	1	9	ns	
			$V_{CC} < 4.5V$		12		
MCLK \uparrow \rightarrow Multiplexed Address delay time	t_{CHMADV}	MCLK, MADATA[15:0]	$V_{CC} \geq 4.5V$	1	t_{OD}	ns	
			$V_{CC} < 4.5V$				
MCLK \uparrow \rightarrow Multiplexed Data output time	t_{CHMADX}		$V_{CC} \geq 4.5V$	1	t_{OD}	ns	
			$V_{CC} < 4.5V$				

Note: When the external load capacitance $C_L = 30pF$.

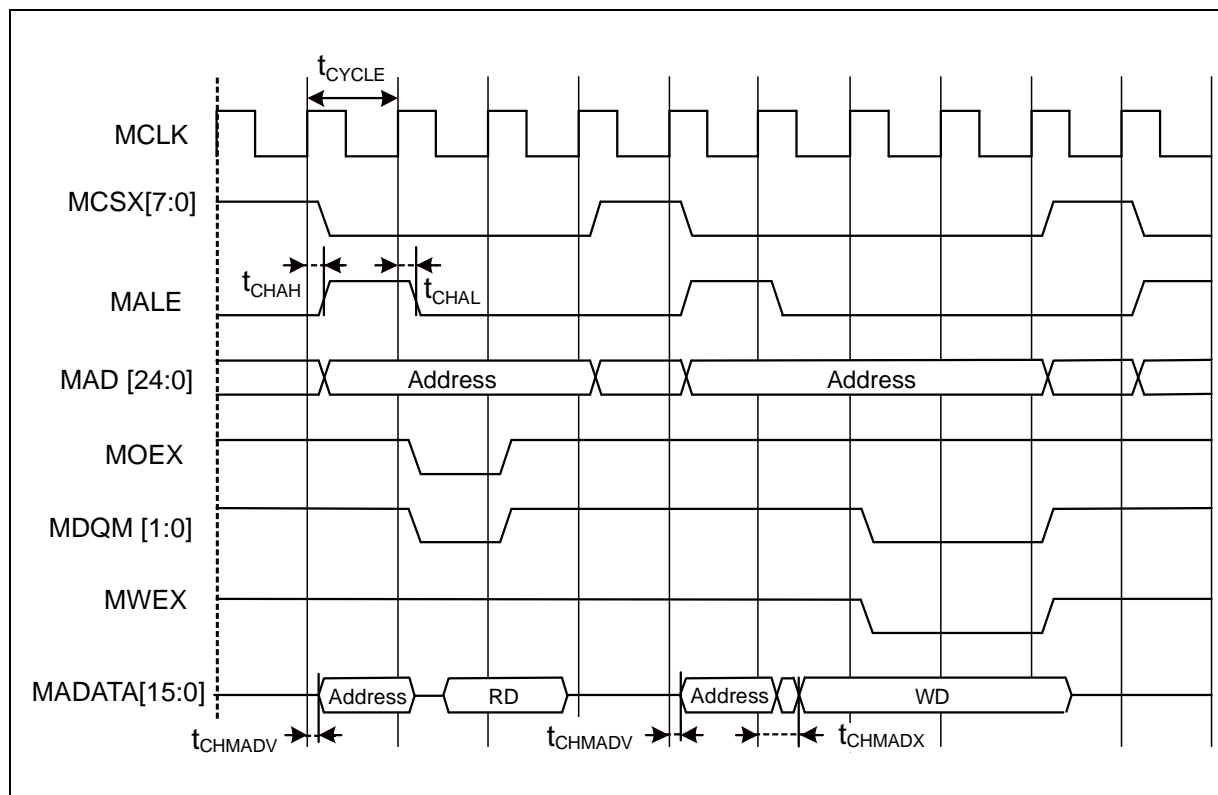

MB9B410T Series

• NAND Flash Mode

($V_{CC} = 2.7V$ to $5.5V$, $V_{SS} = 0V$, $T_a = -40^{\circ}C$ to $+85^{\circ}C$)

Parameter	Symbol	Pin name	Conditions	Value		Unit
				Min	Max	
MNREX Min pulse width	t_{NREW}	MNREX	$V_{CC} \geq 4.5V$	MCLK×n-3	-	ns
			$V_{CC} < 4.5V$			
Data setup → MNREX ↑ time	t_{DS-NRE}	MNREX, MADATA[15:0]	$V_{CC} \geq 4.5V$	20	-	ns
			$V_{CC} < 4.5V$	38	-	
MNREX ↑ → Data hold time	t_{DH-NRE}	MNREX, MADATA[15:0]	$V_{CC} \geq 4.5V$	0	-	ns
			$V_{CC} < 4.5V$			
MNALE ↑ → MNWEX delay time	$t_{ALEH-NWEL}$	MNALE, MNWEX	$V_{CC} \geq 4.5V$	MCLK×m-9	MCLK×m+9	ns
			$V_{CC} < 4.5V$	MCLK×m-12	MCLK×m+12	
MNALE ↓ → MNWEX delay time	$t_{ALEL-NWEL}$	MNALE, MNWEX	$V_{CC} \geq 4.5V$	MCLK×m-9	MCLK×m+9	ns
			$V_{CC} < 4.5V$	MCLK×m-12	MCLK×m+12	
MNCLE ↑ → MNWEX delay time	$t_{CLEH-NWEL}$	MNCLE, MNWEX	$V_{CC} \geq 4.5V$	MCLK×m-9	MCLK×m+9	ns
			$V_{CC} < 4.5V$	MCLK×m-12	MCLK×m+12	
MNWEX ↑ → MNCLE delay time	$t_{NWEH-CLEL}$	MNCLE, MNWEX	$V_{CC} \geq 4.5V$	0	MCLK×m+9	ns
			$V_{CC} < 4.5V$		MCLK×m+12	
MNWEX Min pulse width	t_{NWEW}	MNWEX	$V_{CC} \geq 4.5V$	MCLK×n-3	-	ns
			$V_{CC} < 4.5V$			
MNWEX ↓ → Data output time	$t_{NWEL-DV}$	MNWEX, MADATA[15:0]	$V_{CC} \geq 4.5V$	-9	+9	ns
			$V_{CC} < 4.5V$	-12	+12	
MNWEX ↑ → Data hold time	$t_{NWEH-DX}$	MNWEX, MADATA[15:0]	$V_{CC} \geq 4.5V$	0	MCLK×m+9	ns
			$V_{CC} < 4.5V$		MCLK×m+12	

Note: When the external load capacitance $C_L = 30pF$. (m=0 to 15, n=1 to 16)

MB9B410T Series

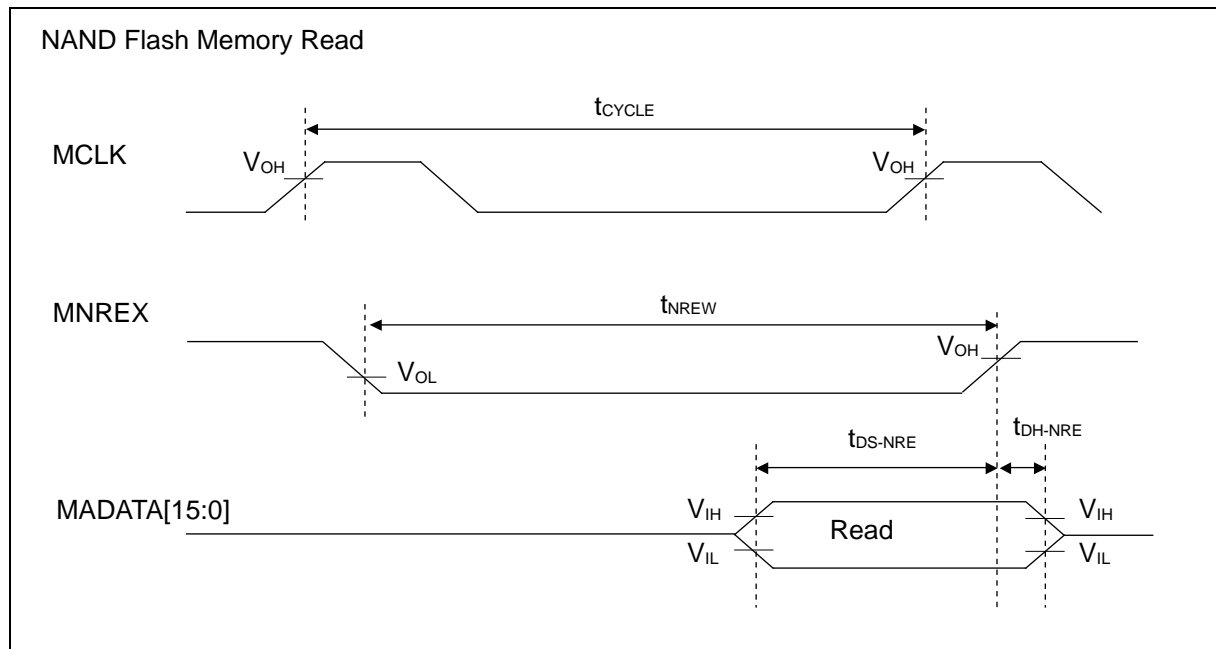

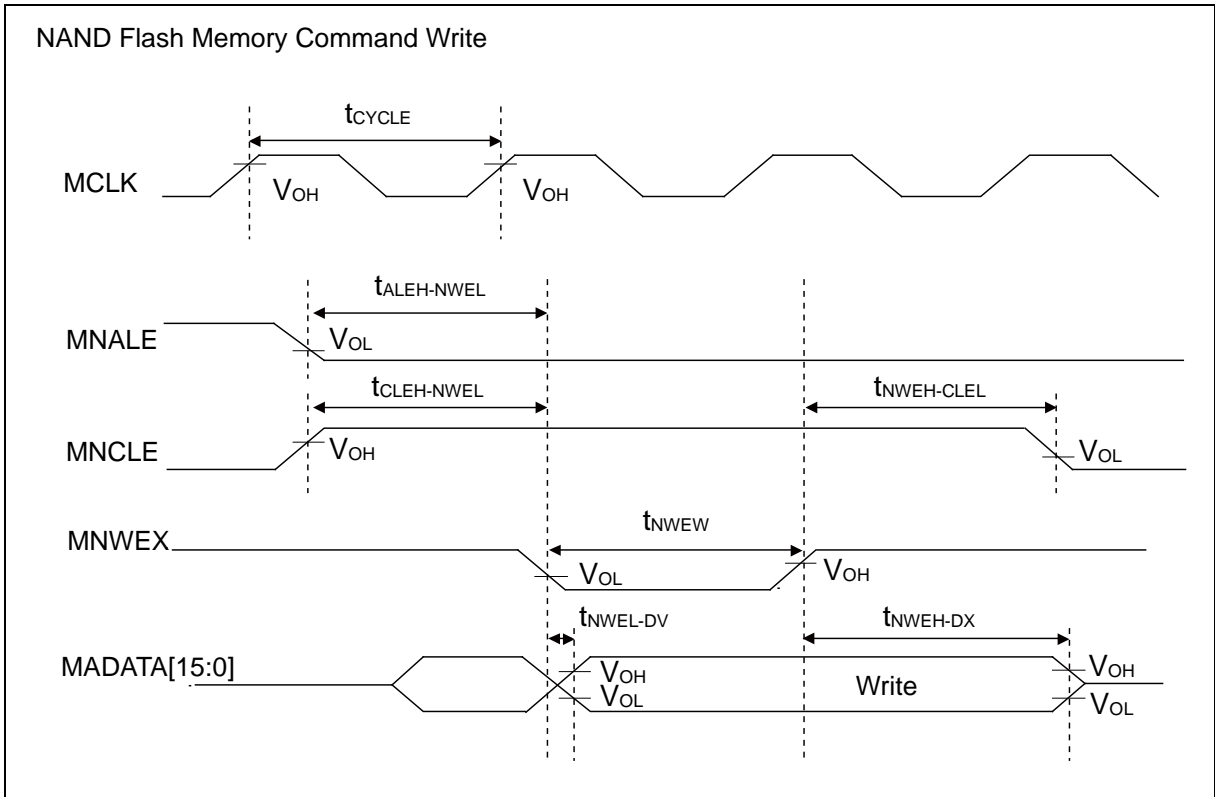
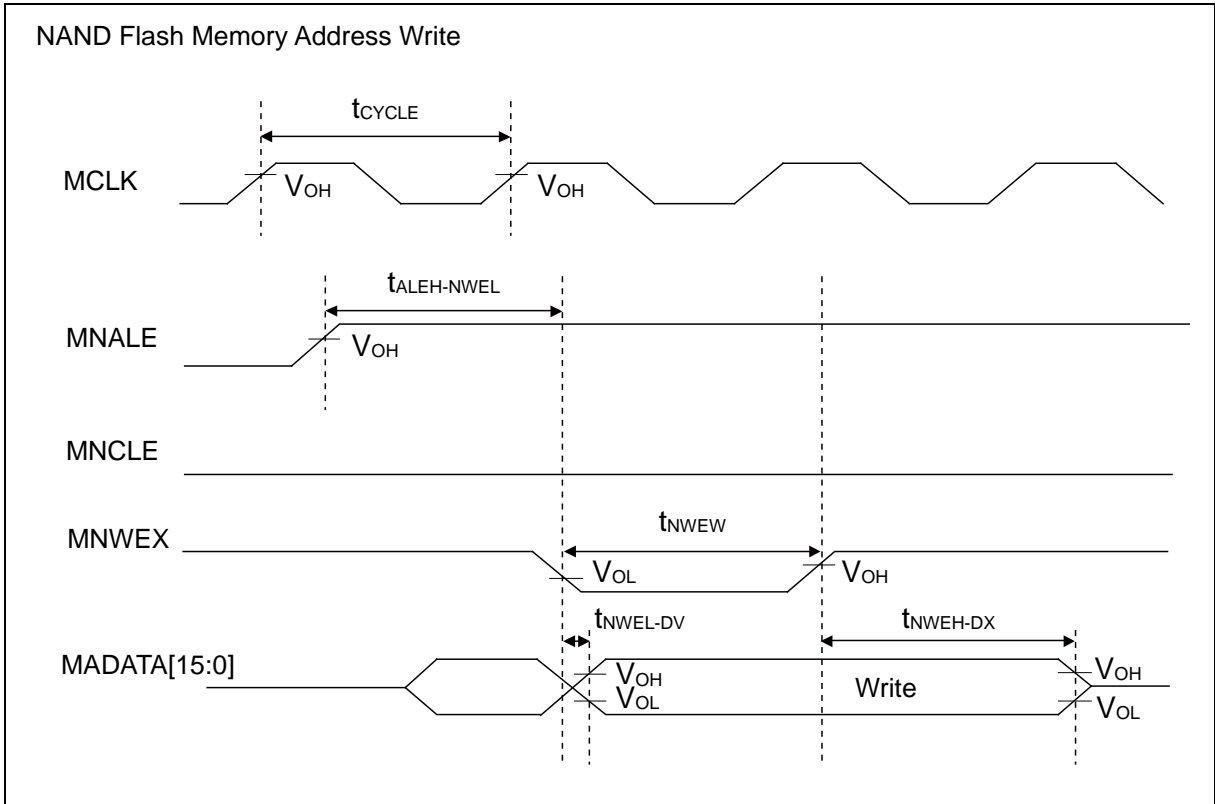

MB9B410T Series

• External Ready Input Timing

($V_{CC} = 2.7V$ to $5.5V$, $V_{SS} = 0V$, $T_a = -40^{\circ}C$ to $+85^{\circ}C$)

Parameter	Symbol	Pin name	Conditions	Value		Unit	Remarks
				Min	Max		
MCLK ↑ MRDY input setup time	t_{RDYI}	MCLK, MRDY	$V_{CC} \geq 4.5V$	19	-	ns	
			$V_{CC} < 4.5V$	37			

• When RDY is input

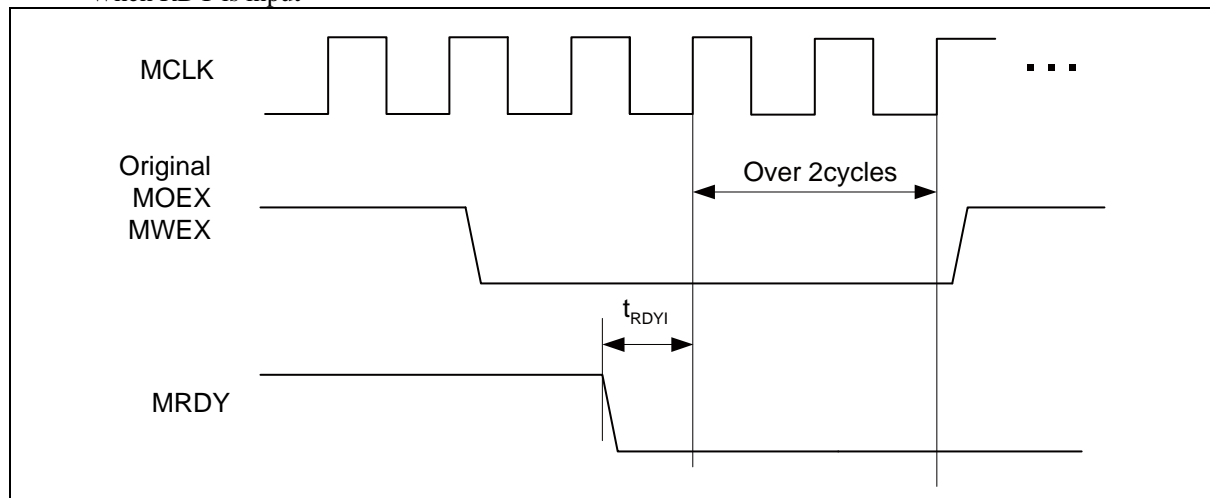

• When RDY is released

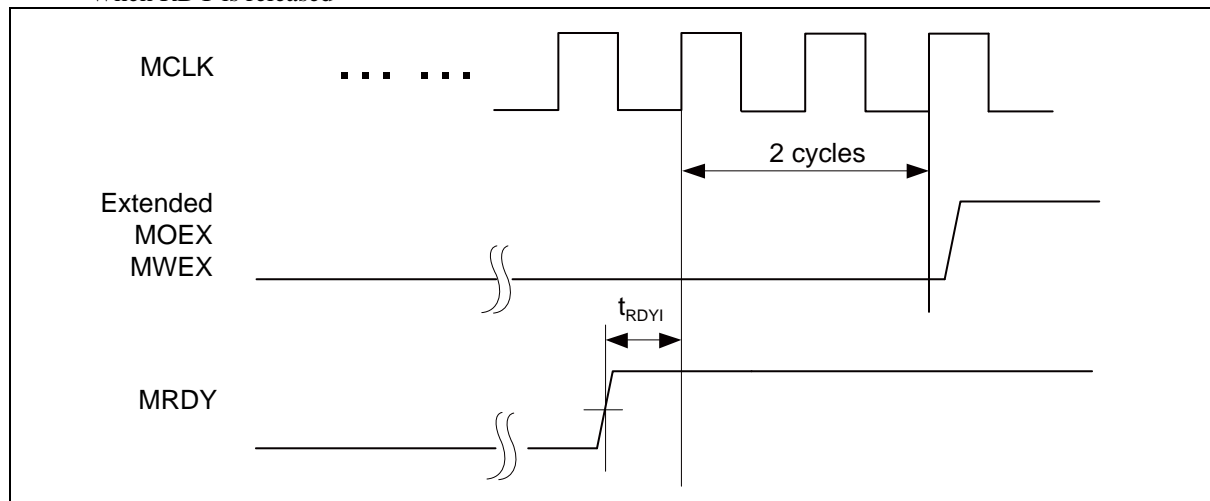

(8) Base Timer Input Timing

- Timer input timing

(V_{CC} = 2.7V to 5.5V, V_{SS} = 0V, T_a = - 40°C to + 85°C)

Parameter	Symbol	Pin name	Conditions	Value		Unit	Remarks
				Min	Max		
Input pulse width	t_{TIWH} , t_{TIWL}	TIOAn/TIOBn (when using as ECK, TIN)	-	$2t_{CYCP}$	-	ns	

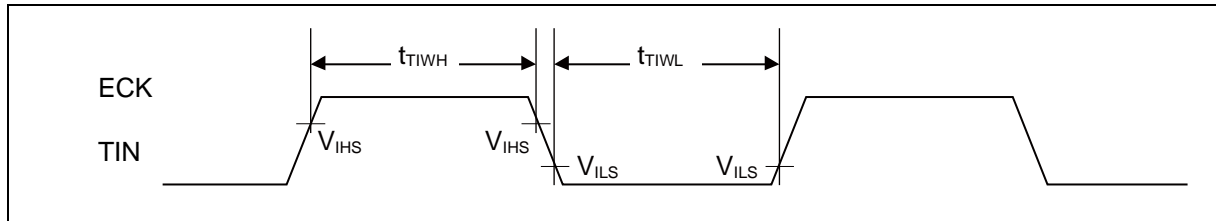

- Trigger input timing

(V_{CC} = 2.7V to 5.5V, V_{SS} = 0V, T_a = - 40°C to + 85°C)

Parameter	Symbol	Pin name	Conditions	Value		Unit	Remarks
				Min	Max		
Input pulse width	t_{TRGH} , t_{TRGL}	TIOAn/TIOBn (when using as TGIN)	-	$2t_{CYCP}$	-	ns	

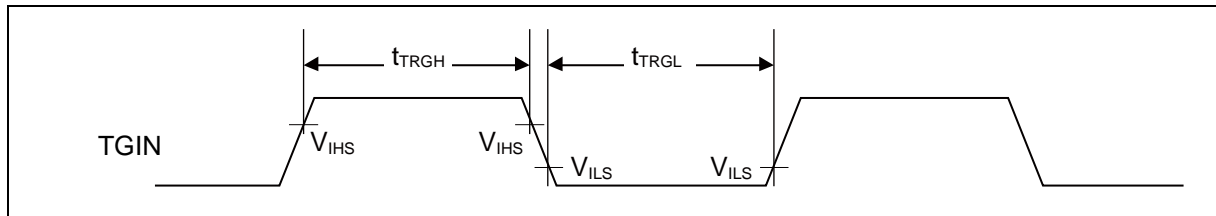

MB9B410T Series

(9) UART Timing

- Synchronous serial (SPI = 0, SCINV = 0)

(V_{CC} = 2.7V to 5.5V, V_{SS} = 0V, T_a = - 40°C to + 85°C)

Parameter	Symbol	Pin name	Conditions	V _{CC} < 4.5V		V _{CC} ≥ 4.5V		Unit
				Min	Max	Min	Max	
Serial clock cycle time	tSCYC	SCK _x	Internal shift clock operation	4t _{CYCP}	-	4t _{CYCP}	-	ns
SCK ↓ → SOT delay time	tSLOVI	SCK _x , SOT _x		-30	+30	- 20	+ 20	ns
SIN → SCK ↑ setup time	tIVSHI	SCK _x , SIN _x		50	-	30	-	ns
SCK ↑ → SIN hold time	tSHIXI	SCK _x , SIN _x		0	-	0	-	ns
Serial clock "L" pulse width	tSLSH	SCK _x	External shift clock operation	2t _{CYCP} - 10	-	2t _{CYCP} - 10	-	ns
Serial clock "H" pulse width	tSHSL	SCK _x		t _{CYCP} + 10	-	t _{CYCP} + 10	-	ns
SCK ↓ → SOT delay time	tSLOVE	SCK _x , SOT _x		-	50	-	30	ns
SIN → SCK ↑ setup time	tIVSHE	SCK _x , SIN _x		10	-	10	-	ns
SCK ↑ → SIN hold time	tSHIXE	SCK _x , SIN _x		20	-	20	-	ns
SCK falling time	tF	SCK _x		-	5	-	5	ns
SCK rising time	tR	SCK _x		-	5	-	5	ns

Notes: · The above characteristics apply to CLK synchronous mode.

- t_{CYCP} indicates the APB bus clock cycle time.
About the APB bus number which UART is connected to, see "■BLOCK DIAGRAM" in this data sheet.
- These characteristics only guarantee the same relocate port number.
For example, the combination of SCLK_x_0 and SOT_x_1 is not guaranteed.
- When the external load capacitance C_L = 30pF.

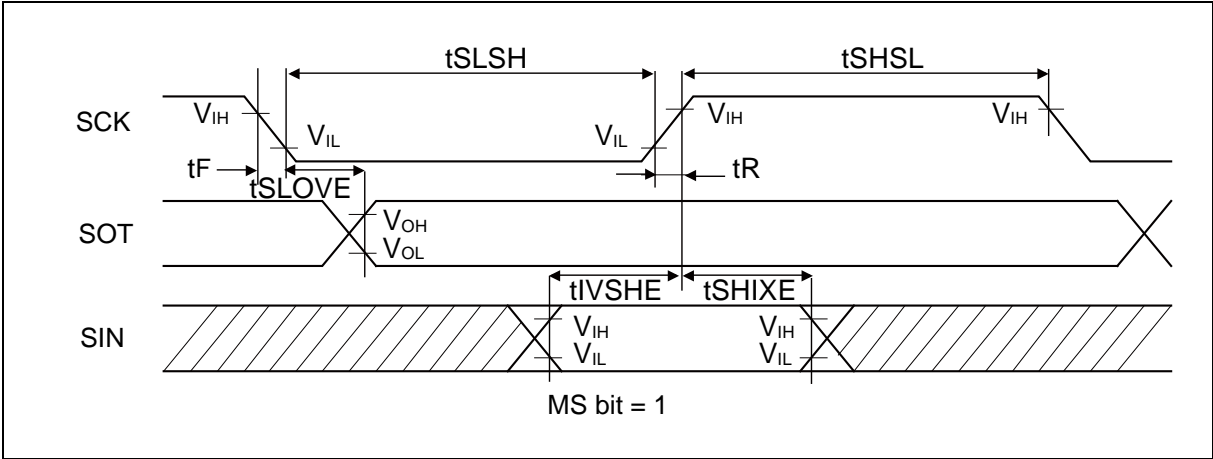
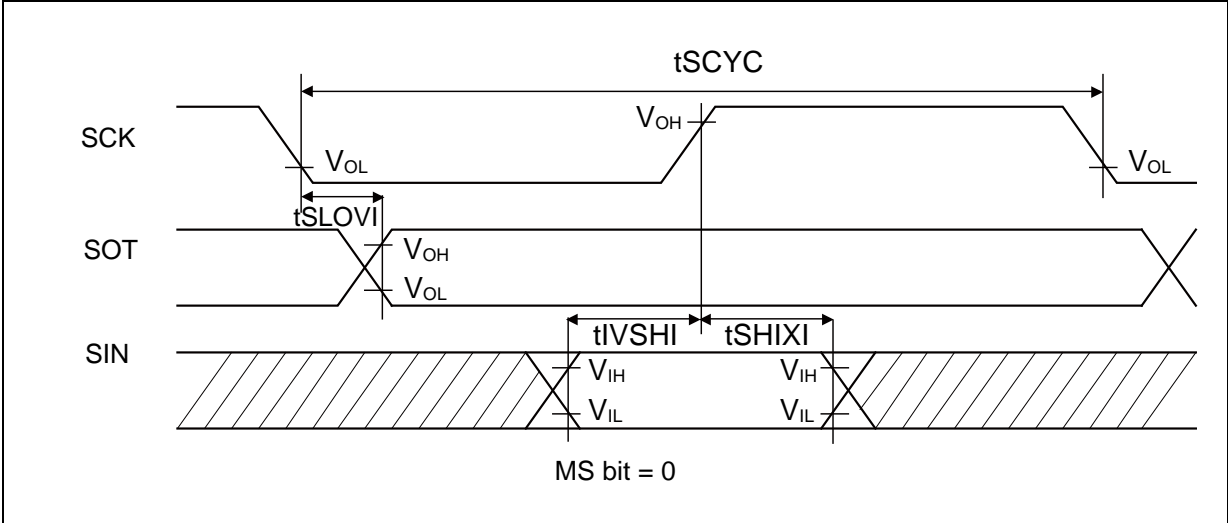

MB9B410T Series

- Synchronous serial (SPI = 0, SCINV = 1)

(V_{CC} = 2.7V to 5.5V, V_{SS} = 0V, T_a = - 40°C to + 85°C)

Parameter	Symbol	Pin name	Conditions	V _{CC} < 4.5V		V _{CC} ≥ 4.5V		Unit
				Min	Max	Min	Max	
Serial clock cycle time	tSCYC	SCK _x	Internal shift clock operation	4t _{CYCP}	-	4t _{CYCP}	-	ns
SCK ↑ → SOT delay time	tSHOVI	SCK _x , SOT _x		-30	+30	- 20	+ 20	ns
SIN → SCK ↓ setup time	tIVSLI	SCK _x , SIN _x		50	-	30	-	ns
SCK ↓ → SIN hold time	tSLIXI	SCK _x , SIN _x		0	-	0	-	ns
Serial clock "L" pulse width	tSLSH	SCK _x	External shift clock operation	2t _{CYCP} - 10	-	2t _{CYCP} - 10	-	ns
Serial clock "H" pulse width	tSHSL	SCK _x		t _{CYCP} + 10	-	t _{CYCP} + 10	-	ns
SCK ↑ → SOT delay time	tSHOVE	SCK _x , SOT _x		-	50	-	30	ns
SIN → SCK ↓ setup time	tIVSLE	SCK _x , SIN _x		10	-	10	-	ns
SCK ↓ → SIN hold time	tSLIXE	SCK _x , SIN _x		20	-	20	-	ns
SCK falling time	tF	SCK _x		-	5	-	5	ns
SCK rising time	tR	SCK _x	-	5	-	5	ns	

Notes: · The above characteristics apply to CLK synchronous mode.

- t_{CYCP} indicates the APB bus clock cycle time.
About the APB bus number which UART is connected to, see "■BLOCK DIAGRAM" in this data sheet.
- These characteristics only guarantee the same relocate port number.
For example, the combination of SCLK_{x_0} and SOT_{x_1} is not guaranteed.
- When the external load capacitance C_L = 30pF.

MB9B410T Series

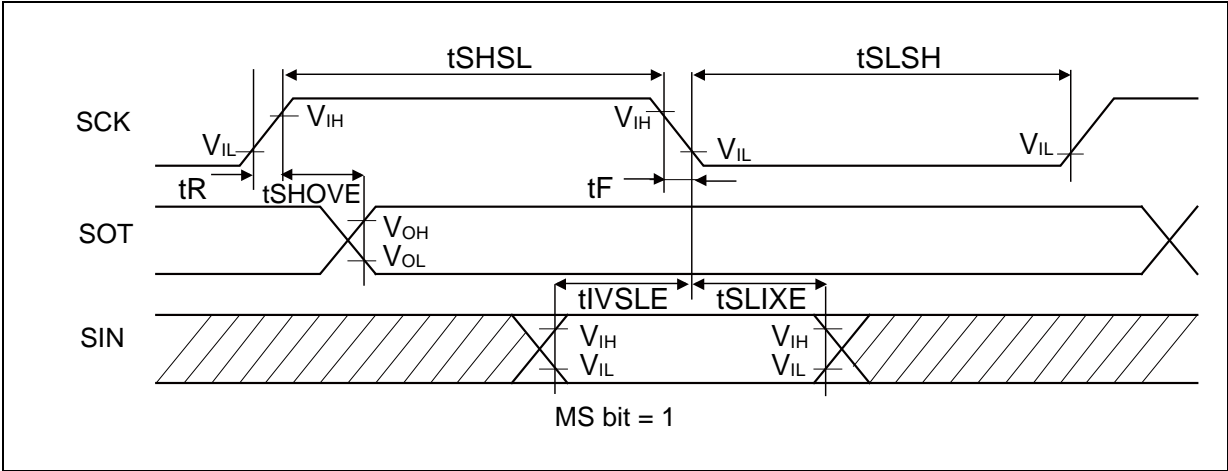
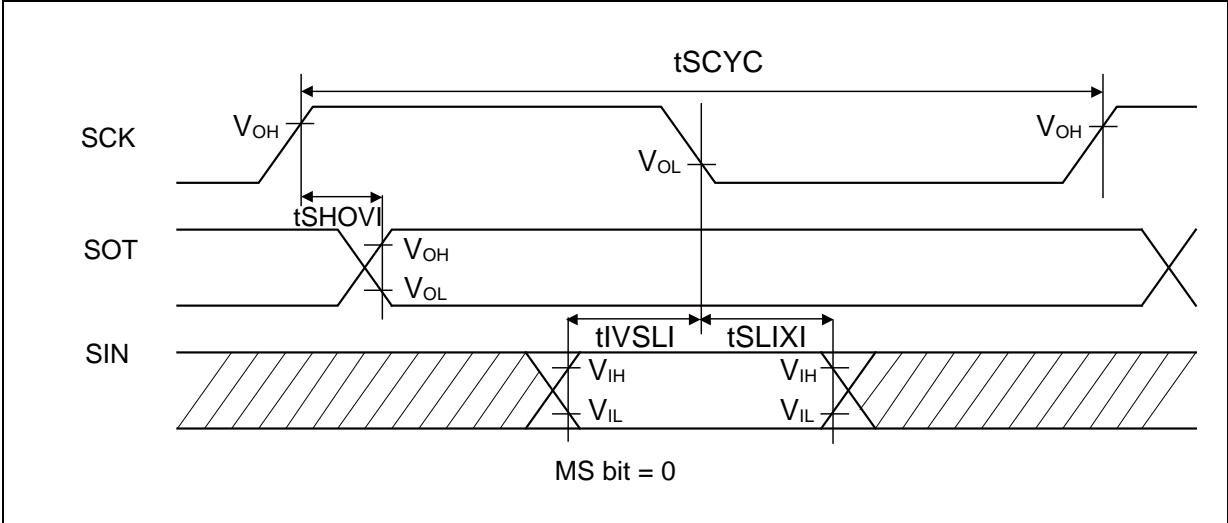

MB9B410T Series

- Synchronous serial (SPI = 1, SCINV = 0)

(Vcc = 2.7V to 5.5V, Vss = 0V, Ta = - 40°C to + 85°C)

Parameter	Symbol	Pin name	Conditions	Vcc < 4.5V		Vcc ≥ 4.5V		Unit
				Min	Max	Min	Max	
Serial clock cycle time	tSCYC	SCKx	Internal shift clock operation	4t _{CYCP}	-	4t _{CYCP}	-	ns
SCK ↑ → SOT delay time	tSHOVI	SCKx, SOTx		-30	+30	- 20	+ 20	ns
SIN → SCK ↓ setup time	tIVSLI	SCKx, SINx		50	-	30	-	ns
SCK ↓ → SIN hold time	tSLIXI	SCKx, SINx		0	-	0	-	ns
SOT → SCK ↓ delay time	tSOVLI	SCKx, SOTx		2t _{CYCP} - 30	-	2t _{CYCP} - 30	-	ns
Serial clock "L" pulse width	tSLSH	SCKx	External shift clock operation	2t _{CYCP} - 10	-	2t _{CYCP} - 10	-	ns
Serial clock "H" pulse width	tSHSL	SCKx		t _{CYCP} + 10	-	t _{CYCP} + 10	-	ns
SCK ↑ → SOT delay time	tSHOVE	SCKx, SOTx		-	50	-	30	ns
SIN → SCK ↓ setup time	tIVSLE	SCKx, SINx		10	-	10	-	ns
SCK ↓ → SIN hold time	tSLIXE	SCKx, SINx		20	-	20	-	ns
SCK falling time	tF	SCKx		-	5	-	5	ns
SCK rising time	tR	SCKx		-	5	-	5	ns

Notes: · The above characteristics apply to CLK synchronous mode.

- t_{CYCP} indicates the APB bus clock cycle time.
About the APB bus number which UART is connected to, see "■BLOCK DIAGRAM" in this data sheet.
- These characteristics only guarantees the same relocate port number.
For example, the combination of SCLKx_0 and SOTx_1 is not guaranteed.
- When the external load capacitance C_L = 30pF.

MB9B410T Series

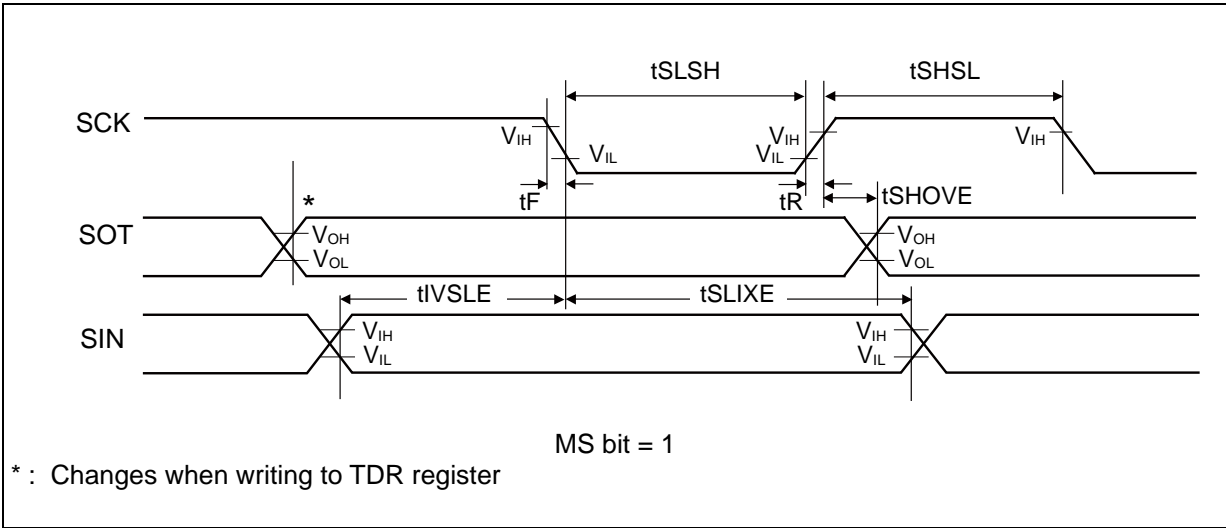
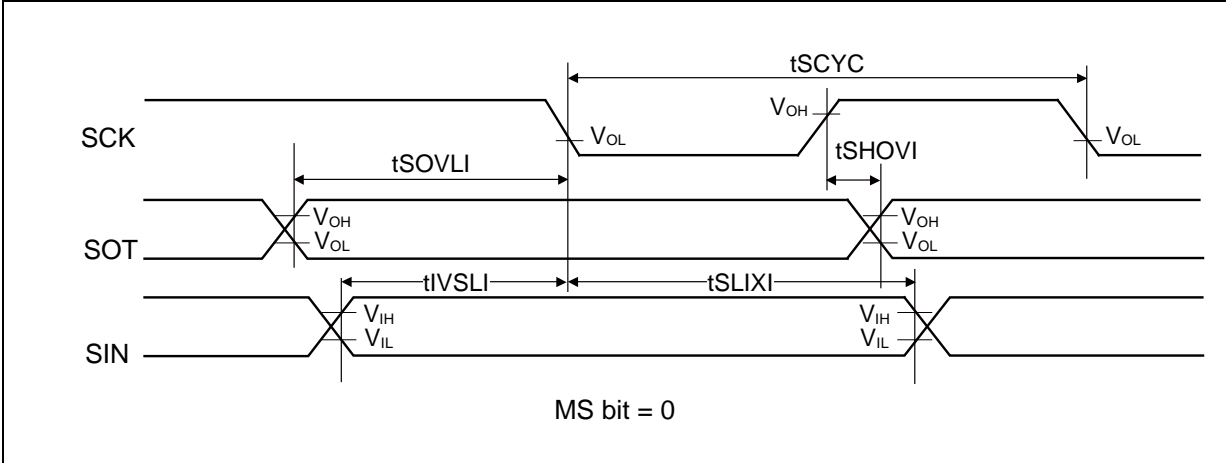

MB9B410T Series

- Synchronous serial (SPI = 1, SCINV = 1)

(V_{CC} = 2.7V to 5.5V, V_{SS} = 0V, T_a = - 40°C to + 85°C)

Parameter	Symbol	Pin name	Conditions	V _{CC} < 4.5V		V _{CC} ≥ 4.5V		Unit
				Min	Max	Min	Max	
Serial clock cycle time	tSCYC	SCK _x	Internal shift clock operation	4t _{CYCP}	-	4t _{CYCP}	-	ns
SCK ↓ → SOT delay time	tSLOVI	SCK _x , SOT _x		-30	+30	- 20	+ 20	ns
SIN → SCK ↑ setup time	tIVSHI	SCK _x , SIN _x		50	-	30	-	ns
SCK ↑ → SIN hold time	tSHIXI	SCK _x , SIN _x		0	-	0	-	ns
SOT → SCK ↑ delay time	tSOVHI	SCK _x , SOT _x		2t _{CYCP} - 30	-	2t _{CYCP} - 30	-	ns
Serial clock "L" pulse width	tSLSH	SCK _x	External shift clock operation	2t _{CYCP} - 10	-	2t _{CYCP} - 10	-	ns
Serial clock "H" pulse width	tSHSL	SCK _x		t _{CYCP} + 10	-	t _{CYCP} + 10	-	ns
SCK ↓ → SOT delay time	tSLOVE	SCK _x , SOT _x		-	50	-	30	ns
SIN → SCK ↑ setup time	tIVSHE	SCK _x , SIN _x		10	-	10	-	ns
SCK ↑ → SIN hold time	tSHIXE	SCK _x , SIN _x		20	-	20	-	ns
SCK falling time	tF	SCK _x		-	5	-	5	ns
SCK rising time	tR	SCK _x		-	5	-	5	ns

Notes: · The above characteristics apply to CLK synchronous mode.

- t_{CYCP} indicates the APB bus clock cycle time.
About the APB bus number which UART is connected to, see "■BLOCK DIAGRAM" in this data sheet.
- These characteristics only guarantee the same relocate port number.
For example, the combination of SCLK_{x_0} and SOT_{x_1} is not guaranteed.
- When the external load capacitance C_L = 30pF.

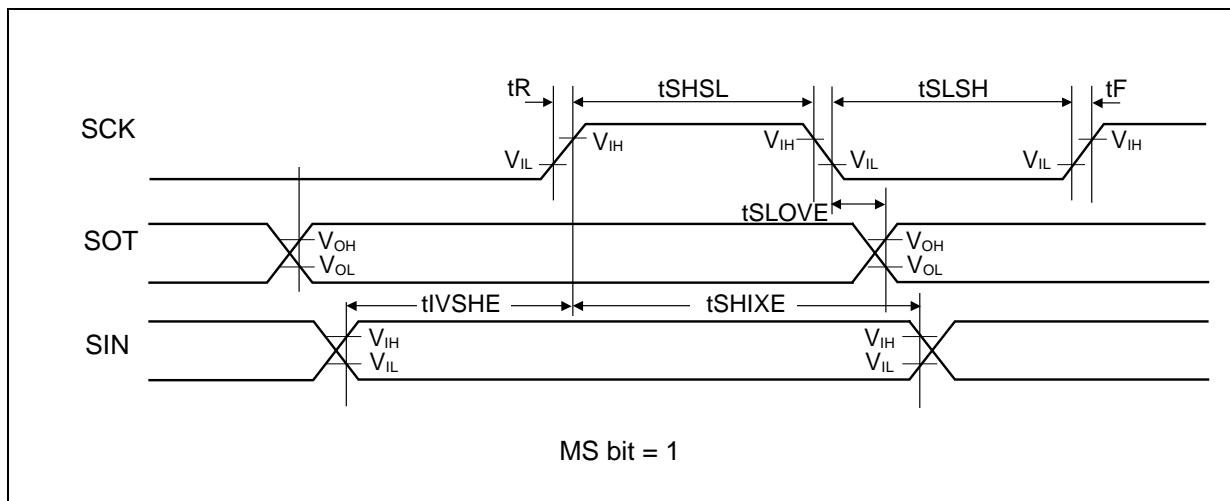
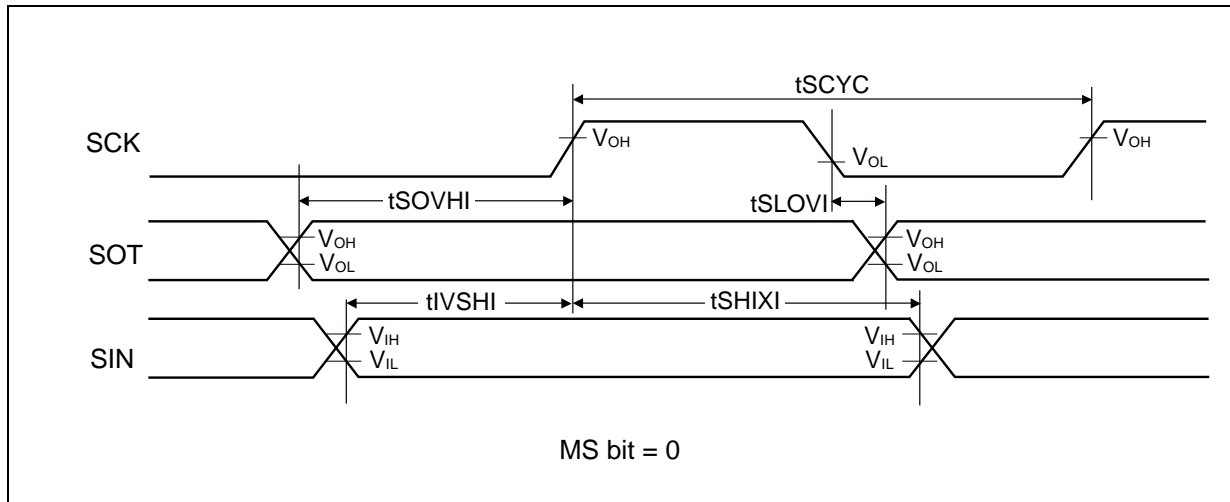

• External clock (EXT = 1) : asynchronous only

(V_{CC} = 2.7V to 5.5V, V_{SS} = 0V, T_a = -40°C to +85°C)

Parameter	Symbol	Conditions	Value		Unit	Remarks
			Min	Max		
Serial clock "L" pulse width	t _{SLSH}	C _L = 30pF	t _{CYCP} + 10	-	ns	
Serial clock "H" pulse width	t _{SHSL}		t _{CYCP} + 10	-	ns	
SCK falling time	t _F		-	5	ns	
SCK rising time	t _R		-	5	ns	

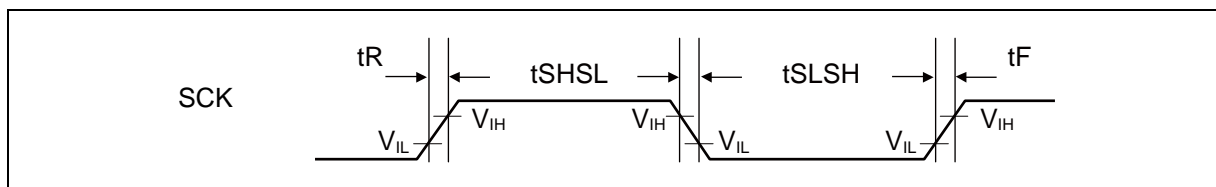

MB9B410T Series

(10) External Input Timing

(V_{CC} = 2.7V to 5.5V, V_{SS} = 0V, T_a = - 40°C to + 85°C)

Parameter	Symbol	Pin name	Conditions	Value		Unit	Remarks
				Min	Max		
Input pulse width	t_{INH} , t_{INL}	ADTG	-	$2t_{CYCP}^{*1}$	-	ns	A/D converter trigger input
		FRCKx					Free-run timer input clock
		ICxx					Input capture
		DTTIxX	-	$2t_{CYCP}^{*1}$	-	ns	Waveform generator
		INT00 to INT31, NMIX	-	$2t_{CYCP} + 100^{*1}$	-	ns	External interrupt NMI
				500^{*2}	-	ns	

*1: t_{CYCP} indicates the APB bus clock cycle time except stop when in stop mode, in timer mode.
About the APB bus number which the Multi-function Timer is connected to, see "■BLOCK DIAGRAM" in this data sheet.

*2: When in stop mode, in timer mode.

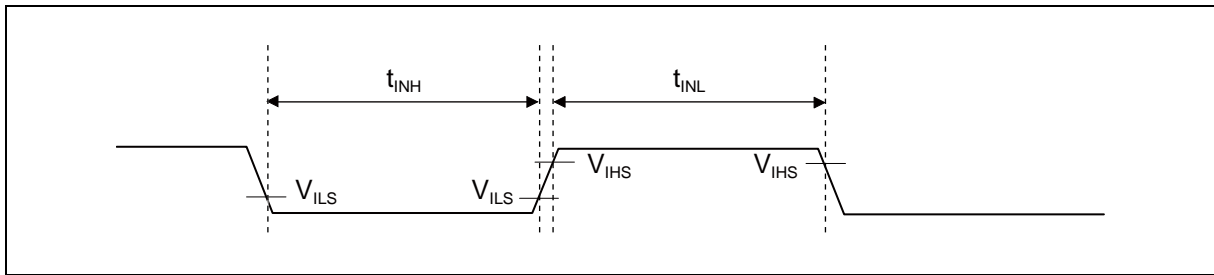

(11) Quadrature Position/Revolution Counter timing

(V_{CC} = 2.7V to 5.5V, V_{SS} = 0V, T_a = -40°C to +85°C)

Parameter	Symbol	Conditions	Value		Unit
			Min	Max	
AIN pin "H" width	tAHL	-	2t _{CYCP} *	-	ns
AIN pin "L" width	tALL	-			
BIN pin "H" width	tBHL	-			
BIN pin "L" width	tBLL	-			
BIN rising time from AIN pin "H" level	tAUBU	PC_Mode2 or PC_Mode3			
AIN falling time from BIN pin "H" level	tBUAD	PC_Mode2 or PC_Mode3			
BIN falling time from AIN pin "L" level	tADBD	PC_Mode2 or PC_Mode3			
AIN rising time from BIN pin "L" level	tBDAU	PC_Mode2 or PC_Mode3			
AIN rising time from BIN pin "H" level	tBUAU	PC_Mode2 or PC_Mode3			
BIN falling time from AIN pin "H" level	tAUBD	PC_Mode2 or PC_Mode3			
AIN falling time from BIN pin "L" level	tBDAD	PC_Mode2 or PC_Mode3			
BIN rising time from AIN pin "L" level	tADBU	PC_Mode2 or PC_Mode3			
ZIN pin "H" width	tZHL	QCR:CGSC="0"			
ZIN pin "L" width	tZLL	QCR:CGSC="0"			
AIN/BIN rising and falling time from determined ZIN level	tZABE	QCR:CGSC="1"			
Determined ZIN level from AIN/BIN rising and falling time	tABEZ	QCR:CGSC="1"			

*: t_{CYCP} indicates the APB bus clock cycle time except stop when in stop mode, in timer mode.

About the APB bus number which the Quadrature Position/Revolution Counter is connected to, see "■ BLOCK DIAGRAM" in this data sheet.

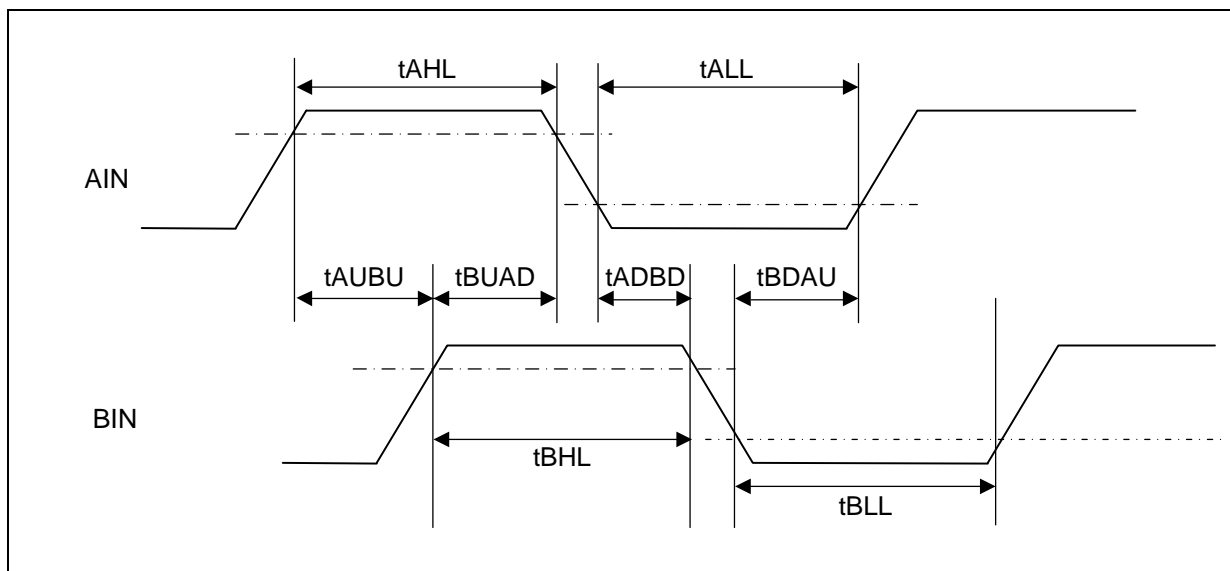

MB9B410T Series

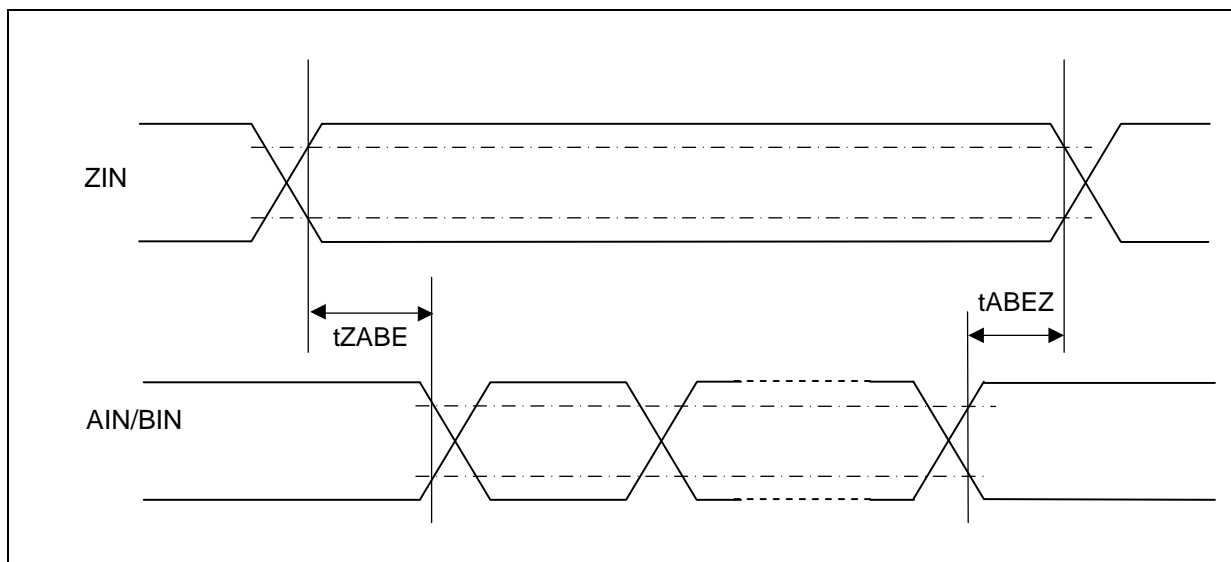
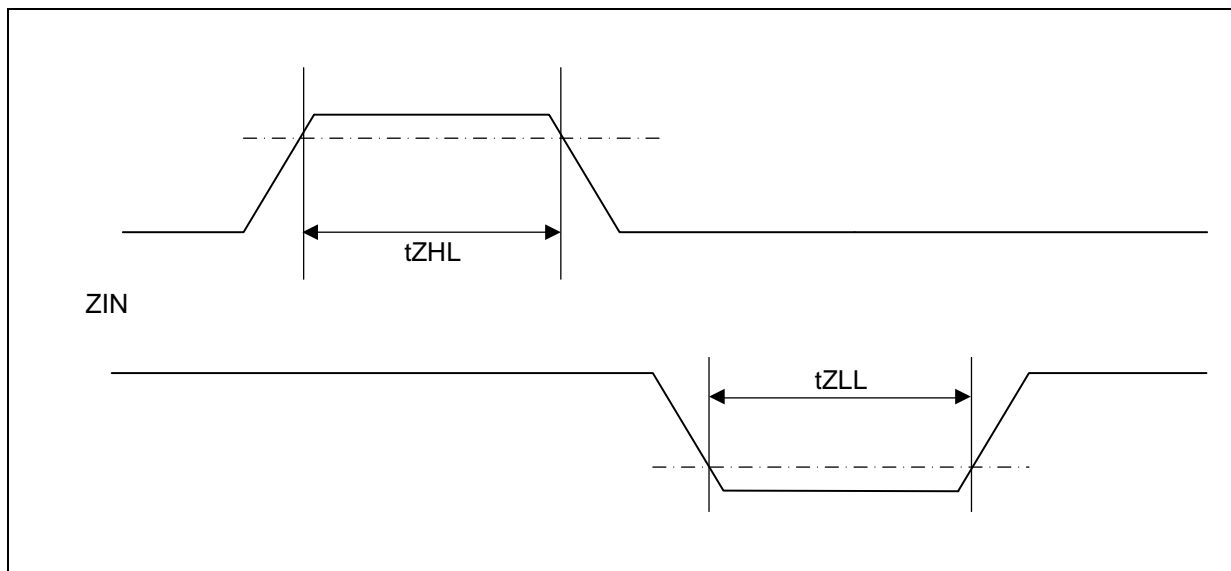
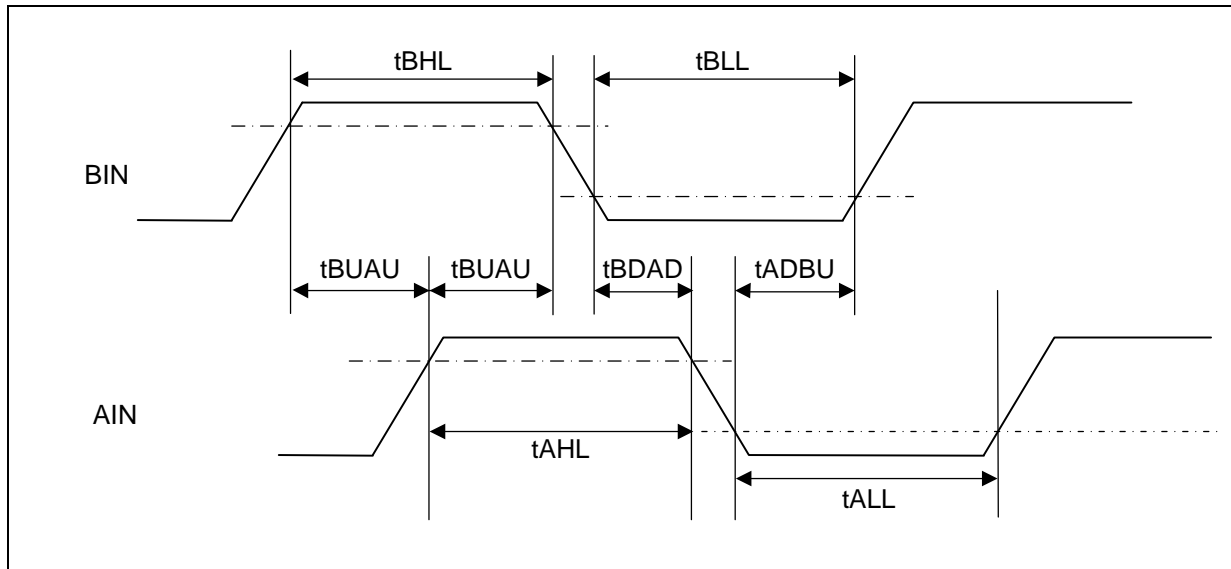

(12) I²C Timing

(V_{CC} = 2.7V to 5.5V, V_{SS} = 0V, T_a = -40°C to +85°C)

Parameter	Symbol	Conditions	Typical mode		High-speed mode		Unit	Remarks
			Min	Max	Min	Max		
SCL clock frequency	fSCL	C _L = 30pF, R = (V _p /I _{OL})* ¹	0	100	0	400	kHz	
(Repeated) START condition hold time SDA ↓ → SCL ↓	tHDSTA		4.0	-	0.6	-	μs	
SCLclock "L" width	tLOW		4.7	-	1.3	-	μs	
SCLclock "H" width	tHIGH		4.0	-	0.6	-	μs	
(Repeated) START condition setup time SCL ↑ → SDA ↓	tSUSTA		4.7	-	0.6	-	μs	
Data hold time SCL ↓ → SDA ↓ ↑	tHDDAT		0	3.45* ²	0	0.9* ³	μs	
Data setup time SDA ↓ ↑ → SCL ↑	tSUDAT		250	-	100	-	ns	
STOP condition setup time SCL ↑ → SDA ↑	tSUSTO		4.0	-	0.6	-	μs	
Bus free time between "STOP condition" and "START condition"	tBUF		4.7	-	1.3	-	μs	
Noise filter	tSP	8MHz ≤ t _{CYCP} ≤ 40MHz	2 t _{CYCP} * ⁴	-	2 t _{CYCP} * ⁴	-	ns	*5
		40MHz < t _{CYCP} ≤ 60MHz	3 t _{CYCP} * ⁴	-	3 t _{CYCP} * ⁴	-	ns	*5
		60MHz < t _{CYCP} ≤ 72MHz	4 t _{CYCP} * ⁴	-	4 t _{CYCP} * ⁴	-	ns	*5

- *1: R and C represent the pull-up resistor and load capacitance of the SCL and SDA lines, respectively. V_p indicates the supply voltage of the pull-up resistor and I_{OL} indicates V_{OL} guaranteed current.
- *2: The maximum tHDDAT must satisfy that it does not extend at least "L" period (tLOW) of device's SCL signal.
- *3: A high-speed mode I²C bus device can be used on a standard mode I²C bus system as long as the device satisfies the requirement of "tSUDAT ≥ 250 ns".
- *4: t_{CYCP} is the APB bus clock cycle time.
About the APB bus number which I²C is connected to, see "■BLOCK DIAGRAM" in this data sheet.
To use I²C, set the peripheral bus clock at 8 MHz or more.
- *5: The number of steps of the noise filter can be changed to 2, 3 or 4 steps with register settings.
Change the number of the noise filter steps according to APB2 bus clock frequency.

MB9B410T Series

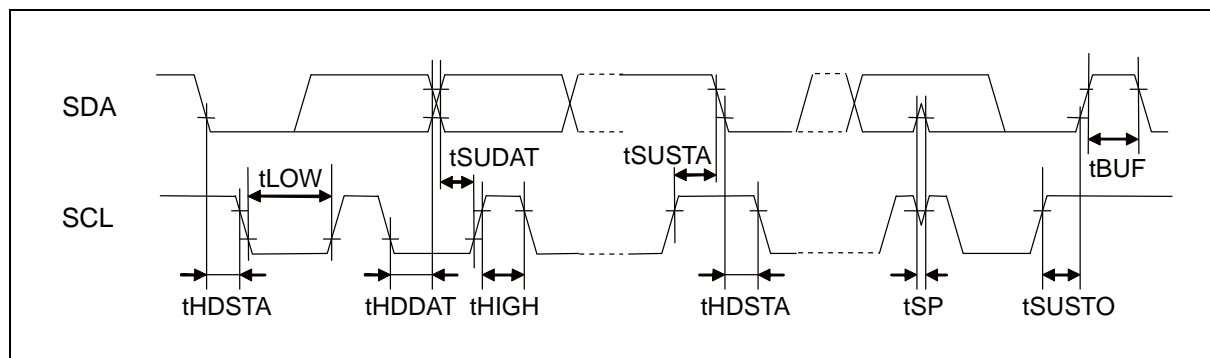

(13) ETM Timing

($V_{CC} = 2.7V$ to $5.5V$, $V_{SS} = 0V$, $T_a = -40^{\circ}C$ to $+85^{\circ}C$)

Parameter	Symbol	Pin name	Conditions	Value		Unit	Remarks
				Min	Max		
Data hold	t_{ETMH}	TRACECLK, TRACED[3:0]	$V_{CC} \geq 4.5V$	2	9	ns	
			$V_{CC} < 4.5V$	2	15		
TRACECLK frequency	$1/t_{TRACE}$	TRACECLK	$V_{CC} \geq 4.5V$	-	50	MHz	
			$V_{CC} < 4.5V$	-	32	MHz	
TRACECLK clock cycle	t_{TRACE}	TRACECLK	$V_{CC} \geq 4.5V$	20	-	ns	
			$V_{CC} < 4.5V$	31.25	-	ns	

Note: When the external load capacitance $C_L = 30pF$.

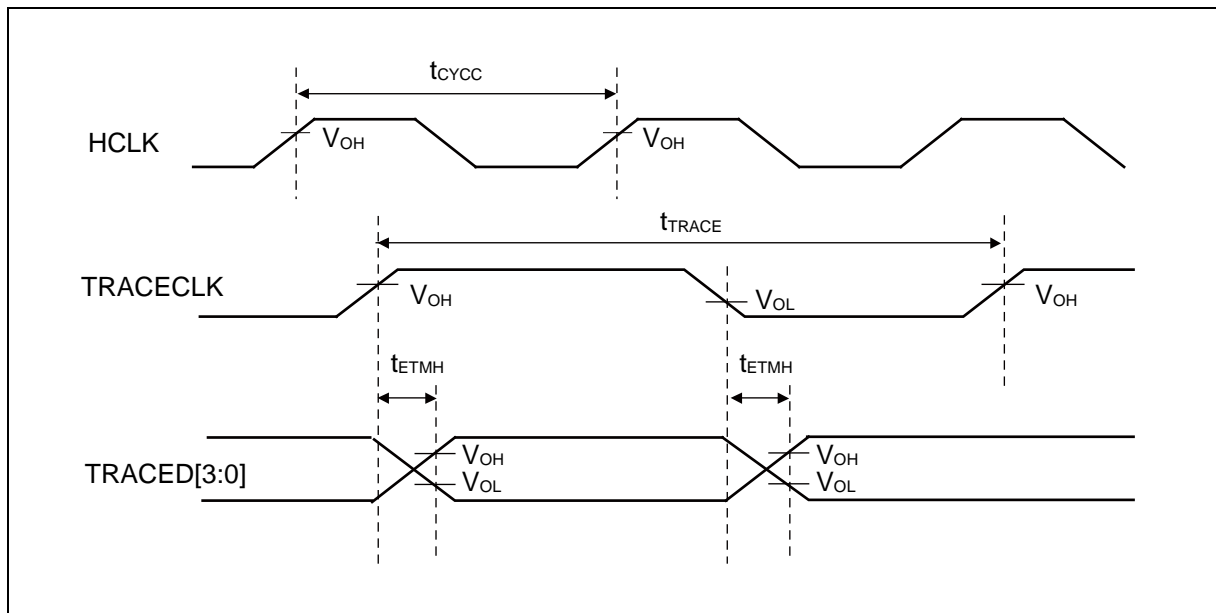

MB9B410T Series

(14) JTAG Timing

($V_{CC} = 2.7V$ to $5.5V$, $V_{SS} = 0V$, $T_a = -40^{\circ}C$ to $+85^{\circ}C$)

Parameter	Symbol	Pin name	Conditions	Value		Unit	Remarks
				Min	Max		
TMS,TDI setup time	$t_{JT\text{AGS}}$	TCK, TMS,TDI	$V_{CC} \geq 4.5V$	15	-	ns	
			$V_{CC} < 4.5V$				
TMS,TDI hold time	$t_{JT\text{AGH}}$	TCK, TMS,TDI	$V_{CC} \geq 4.5V$	15	-	ns	
			$V_{CC} < 4.5V$				
TDO delay time	$t_{JT\text{AGD}}$	TCK, TDO	$V_{CC} \geq 4.5V$	-	25	ns	
			$V_{CC} < 4.5V$	-	45		

Note: When the external load capacitance $C_L = 30pF$.

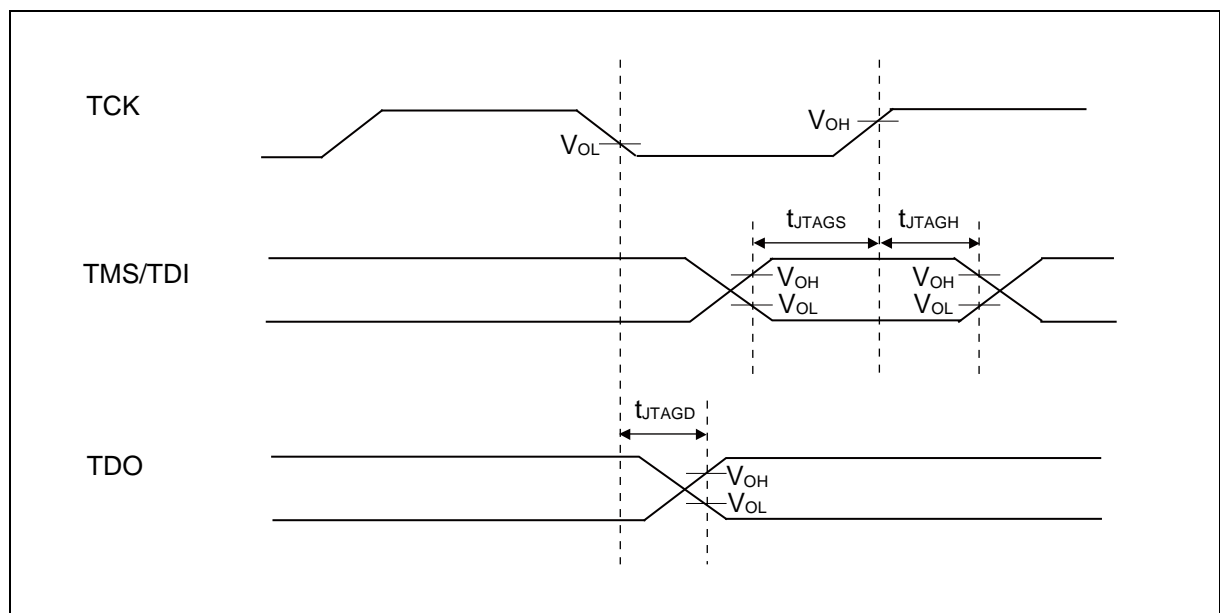

5. 12-bit A/D Converter

• Electrical Characteristics for the A/D Converter.

($V_{CC} = AV_{CC} = 2.7V$ to $5.5V$, $V_{SS} = AV_{SS} = 0V$, $T_a = -40^{\circ}C$ to $+85^{\circ}C$)

Parameter	Symbol	Pin name	Value			Unit	Remarks
			Min	Typ	Max		
Resolution	-	-	-	-	12	bit	
Non-linearity error	-	-	- 4.5	-	+ 4.5	LSB	AVRH = 2.7V to 5.5V
Differential linearity error	-	-	-2.5	-	+ 2.5	LSB	
Zero transition voltage	V_{0T}	AN0 to AN31	- 20	-	+ 20	mV	
Full-scale transition voltage	V_{FST}	AN0 to AN31	AVRH - 20	-	AVRH + 20	mV	
Conversion time	-	-	1.0* ¹	-	-	μs	AVCC \geq 4.5V
Sampling time	T_s	-	*2	-	-	ns	AVCC \geq 4.5V
			*2	-	-		AVCC < 4.5V
Compare clock cycle* ³	T_{cck}	-	50	-	2000	ns	
State transition time to operation permission	T_{stt}	-	1.0	-	-	μs	
Power supply current (analog + digital)	-	AVCC	-	0.57	0.72	mA	A/D lunit operation
			-	0.06	35	μA	When A/D stops
Reference power supply current (between AVRH and AVSS)	-	AVRH	-	1.1	1.96	mA	A/D lunit operation AVRH=5.5V
			-	0.06	4	μA	When A/D stops
Analog input capacity	C_{in}	-	-	-	12.9	pF	
Analog input resistor	R_{in}	-	-	-	2	k Ω	AVCC \geq 4.5V
					3.8		AVCC < 4.5V
Interchannel disparity	-	-	-	-	4	LSB	
Analog port input current	-	AN0 to AN31	-	-	5	μA	
Analog input voltage	-	AN0 to AN31	AVSS	-	AVRH	V	
Reference voltage	-	AVRH	AVSS	-	AVCC	V	

*1: The conversion time is the value of sampling time(T_s) + compare time(T_c).

The condition of the minimum conversion time is when the value of sampling time: 300ns, the value of compare time: 700ns (AVCC \geq 4.5V).

Ensure that it satisfies the value of sampling time(T_s) and compare clock cycle (T_{cck}).

For setting*⁴ of the sampling time and compare clock cycle, see "Chapter: A/D Converter" in "FM3 Family PERIPHERAL MANUAL Analog Macro Part".

The A/D Converter register is set at the peripheral clock timing. The sampling clock and compare clock are set at Base clock (HCLK).

*2: A necessary sampling time changes by external impedance.

Ensure that it sets the sampling time to satisfy (Equation 1).

*3: The compare time (T_c) is the value of (Equation 2).

*4: The register setting of the A/D Converter is set at the timing of the APB bus clock.

The sampling clock and compare clock are set with the base clock (HCLK).

About the APB bus number which the A/D Converter is connected to, see "■ BLOCK DIAGRAM" in this data sheet.

MB9B410T Series

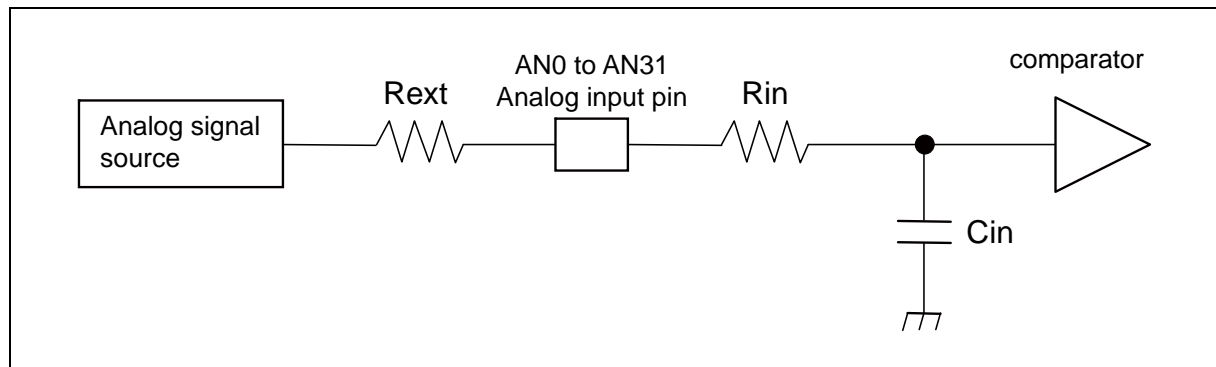

$$\text{(Equation 1) } T_s \geq (R_{in} + R_{ext}) \times C_{in} \times 9$$

T_s : Sampling time

R_{in} : input resistor of A/D = 2k Ω at $4.5 \leq AVCC \leq 5.5$
input resistor of A/D = 3.8k Ω at $2.7 \leq AVCC < 4.5$

C_{in} : input capacity of A/D = 12.9pF at $2.7 \leq AVCC \leq 5.5$

R_{ext} : Output impedance of external circuit

$$\text{(Equation 2) } T_c = T_{cck} \times 14$$

T_c : Compare time

T_{cck} : Compare clock cycle

• Definition of 12-bit A/D Converter Terms

- Resolution : Analog variation that is recognized by an A/D converter.
- Linearity error : Deviation of the line between the zero-transition point (0b000000000000) and the full-scale transition point (0b111111111111) from the actual conversion characteristics.
- Differential linearity error : Deviation from the ideal value of the input voltage that is required to change the output code by 1 LSB.

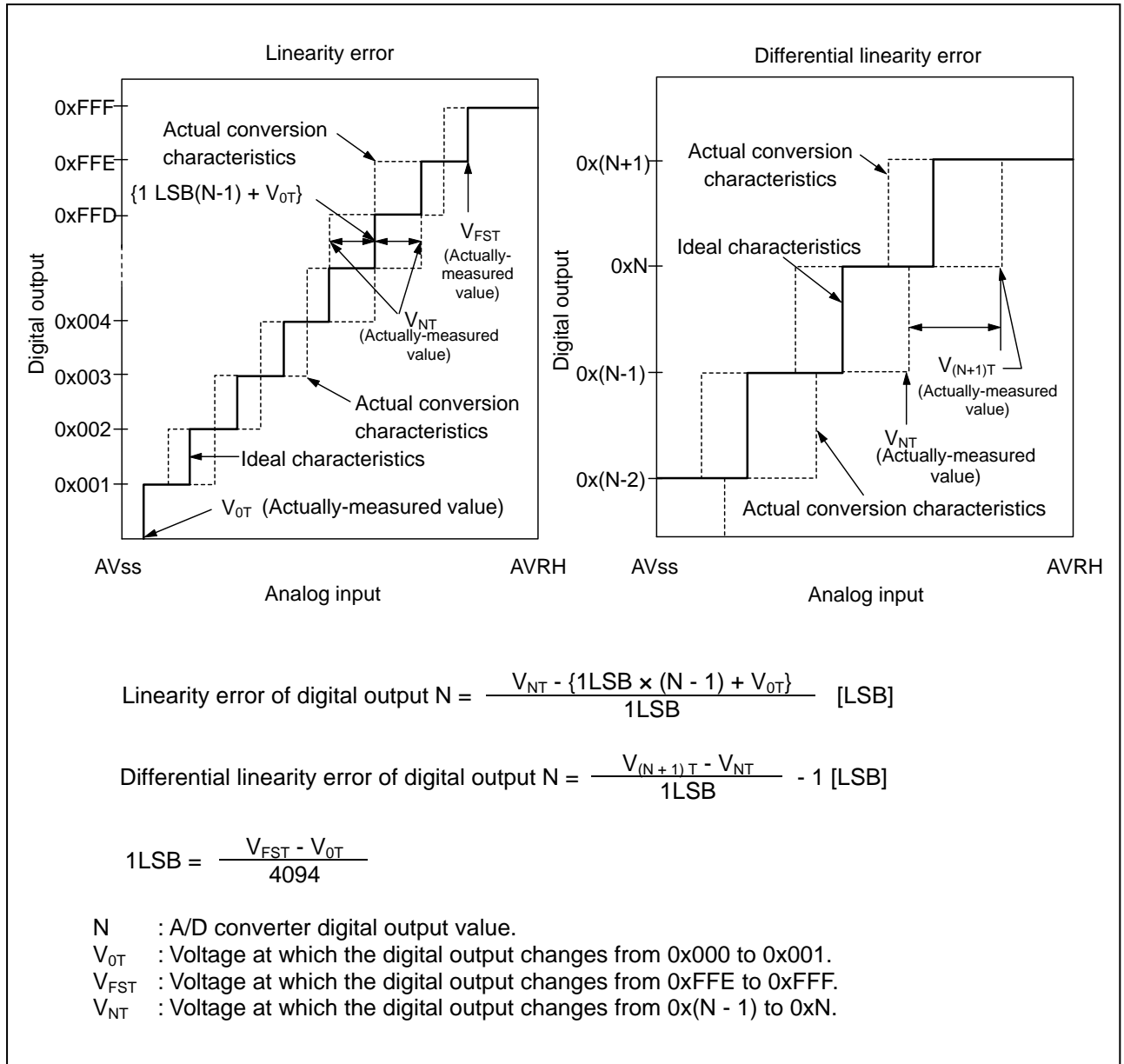

MB9B410T Series

6. Low-voltage Detection Characteristics

(1) Low-voltage Detection Reset

(Ta = - 40°C to + 85°C)

Parameter	Symbol	Conditions	Value			Unit	Remarks
			Min	Typ	Max		
Detected voltage	VDL	-	2.25	2.45	2.65	V	When voltage drops
Released voltage	VDH	-	2.30	2.50	2.70	V	When voltage rises

(2) Interrupt of Low-voltage Detection

(Ta = - 40°C to + 85°C)

Parameter	Symbol	Conditions	Value			Unit	Remarks
			Min	Typ	Max		
Detected voltage	VDL	SVHI = 0000	2.58	2.8	3.02	V	When voltage drops
Released voltage	VDH		2.67	2.9	3.13	V	When voltage rises
Detected voltage	VDL	SVHI = 0001	2.76	3.0	3.24	V	When voltage drops
Released voltage	VDH		2.85	3.1	3.34	V	When voltage rises
Detected voltage	VDL	SVHI = 0010	2.94	3.2	3.45	V	When voltage drops
Released voltage	VDH		3.04	3.3	3.56	V	When voltage rises
Detected voltage	VDL	SVHI = 0011	3.31	3.6	3.88	V	When voltage drops
Released voltage	VDH		3.40	3.7	3.99	V	When voltage rises
Detected voltage	VDL	SVHI = 0100	3.40	3.7	3.99	V	When voltage drops
Released voltage	VDH		3.50	3.8	4.10	V	When voltage rises
Detected voltage	VDL	SVHI = 0111	3.68	4.0	4.32	V	When voltage drops
Released voltage	VDH		3.77	4.1	4.42	V	When voltage rises
Detected voltage	VDL	SVHI = 1000	3.77	4.1	4.42	V	When voltage drops
Released voltage	VDH		3.86	4.2	4.53	V	When voltage rises
Detected voltage	VDL	SVHI = 1001	3.86	4.2	4.53	V	When voltage drops
Released voltage	VDH		3.96	4.3	4.64	V	When voltage rises
LVD stabilization wait time	T _{LVDW}	-	-	-	4032 × t _{CYCP} *	μs	

*: t_{CYCP} indicates the APB2 bus clock cycle time.

7. Flash Memory Write/Erase Characteristics

(V_{cc} = 2.7V to 5.5V, T_a = - 40°C to + 85°C)

Parameter		Value			Unit	Remarks
		Min	Typ	Max		
Sector erase time	Large Sector	-	0.7	3.7	s	Includes write time prior to internal erase
	Small Sector		0.3	1.1		
Half word (16-bit) write time		-	12	384	μs	Not including system-level overhead time
Chip erase time		-	13.6	68	s	Includes write time prior to internal erase

Write cycles and data hold time

Erase/write cycles(cycle)	Data hold time(year)	Remarks
1,000	20*	
10,000	10*	
100,000	5*	

*: This value comes from the technology qualification (using Arrhenius equation to translate high temperature measurements into normalized value at + 85°C).

MB9B410T Series

■ ORDERING INFORMATION

Part number	Package
MB9BF416SPMC	144-pin plastic LQFP (0.5mm pitch), (FPT-144P-M08)
MB9BF417SPMC	
MB9BF418SPMC	
MB9BF416TPMC	176-pin plastic LQFP (0.5mm pitch), (FPT-176P-M07)
MB9BF417TPMC	
MB9BF418TPMC	
MB9BF416TBGL	192-ball plastic FBGA (0.8mm pitch), (BGA-192P-M06)
MB9BF417TBGL	
MB9BF418TBGL	

MB9B410T Series

■ PACKAGE DIMENSIONS

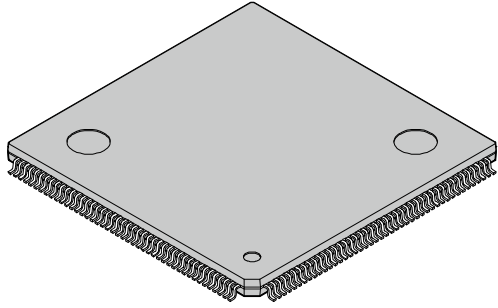
<p>176-pin plastic LQFP</p>  <p>(FPT-176P-M07)</p>	Lead pitch	0.50 mm
	Package width × package length	24.0 × 24.0 mm
	Lead shape	Gullwing
	Sealing method	Plastic mold
	Mounting height	1.70 mm MAX
	Code (Reference)	P-LQFP-0176-2424-0.50

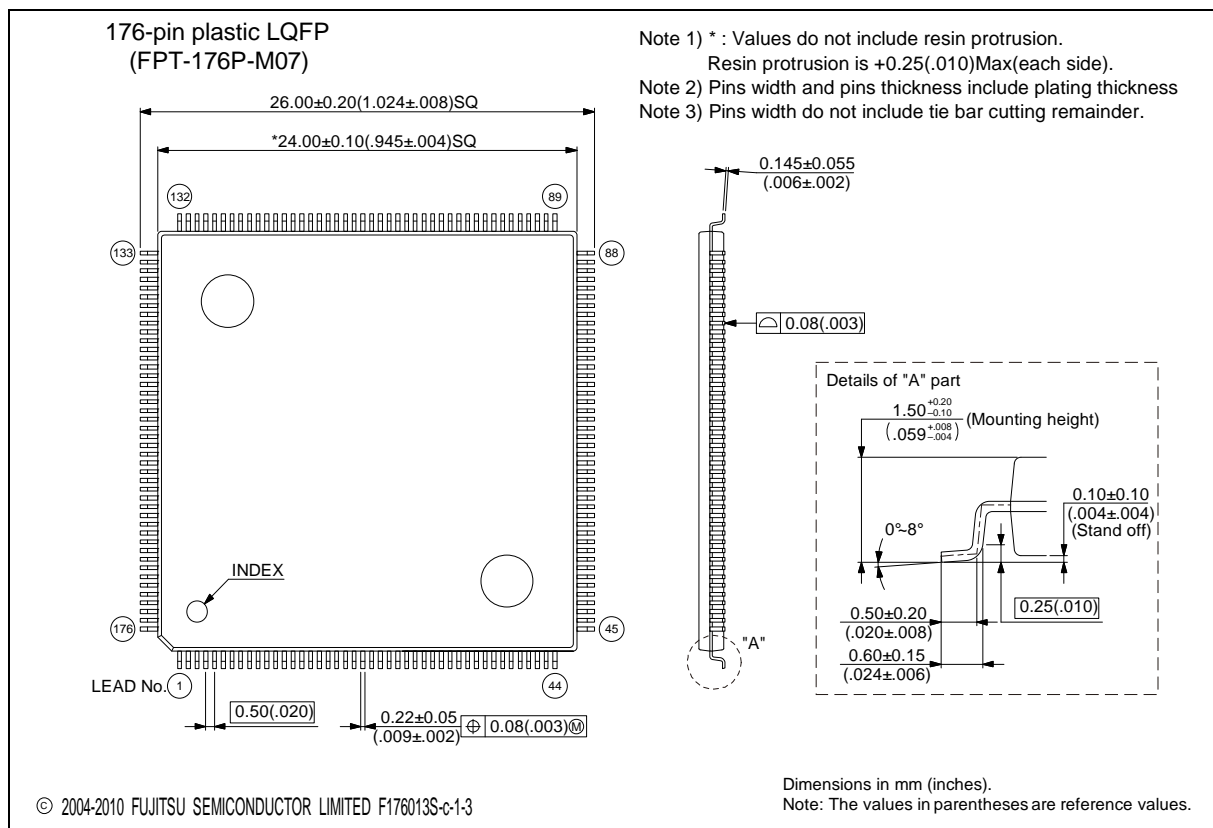

Please check the latest package dimension at the following URL.
<http://edevice.fujitsu.com/package/en-search/>

MB9B410T Series

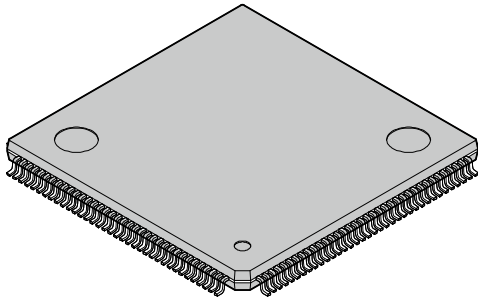
<p>144-pin plastic LQFP</p>  <p>(FPT-144P-M08)</p>	Lead pitch	0.50 mm
	Package width x package length	20.0 x 20.0 mm
	Lead shape	Gullwing
	Sealing method	Plastic mold
	Mounting height	1.70 mm MAX
	Weight	1.20 g
	Code (Reference)	P-LFQFP144-20x20-0.50

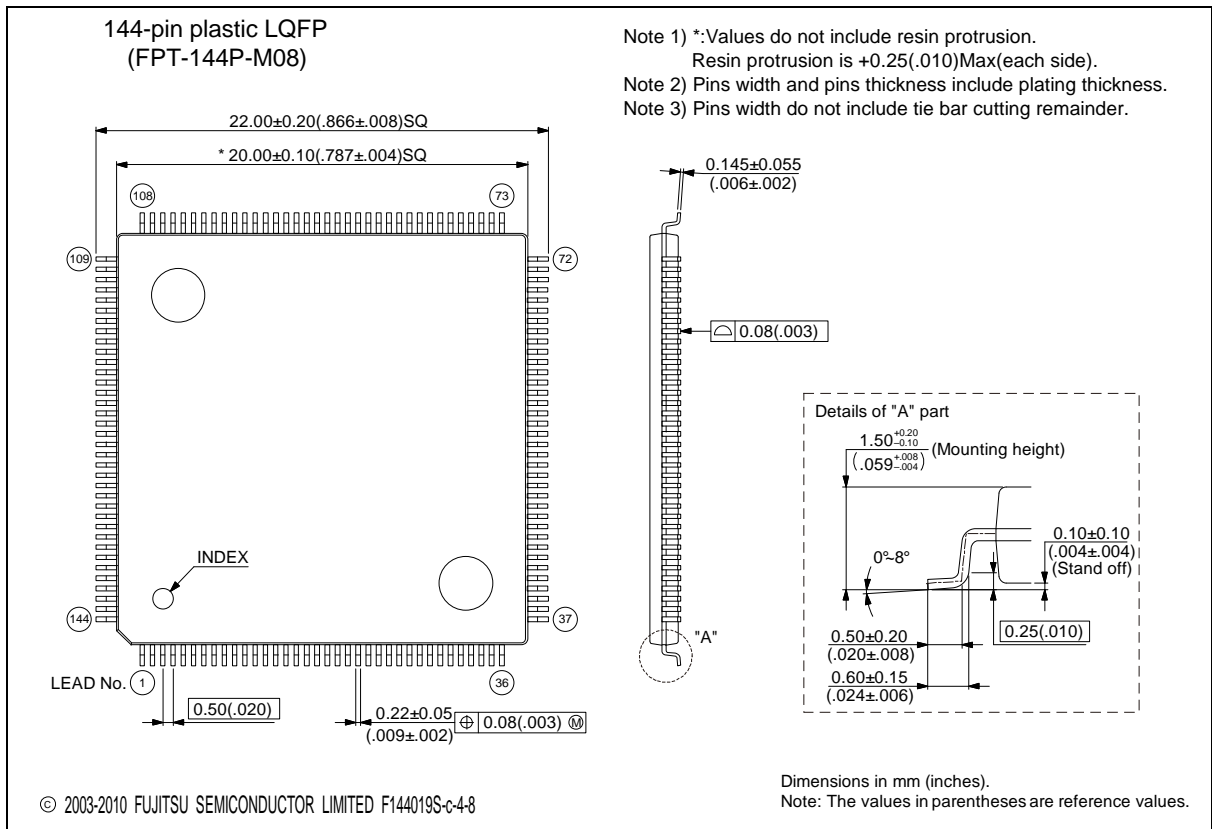

Please check the latest package dimension at the following URL.
<http://edevic.fujitsu.com/package/en-search/>

MB9B410T Series

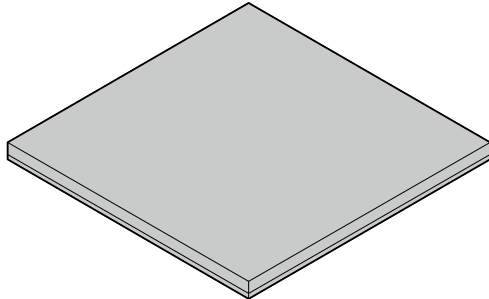
<p style="text-align: center;">192-ball plastic FBGA</p>  <p style="text-align: center;">(BGA-192P-M06)</p>	Ball pitch	0.80 mm
	Package width x package length	12.00 mm x 12.00 mm
	Lead shape	Ball
	Sealing method	Plastic mold
	Mounting height	1.45 mm Max.
	Weight	0.34 g

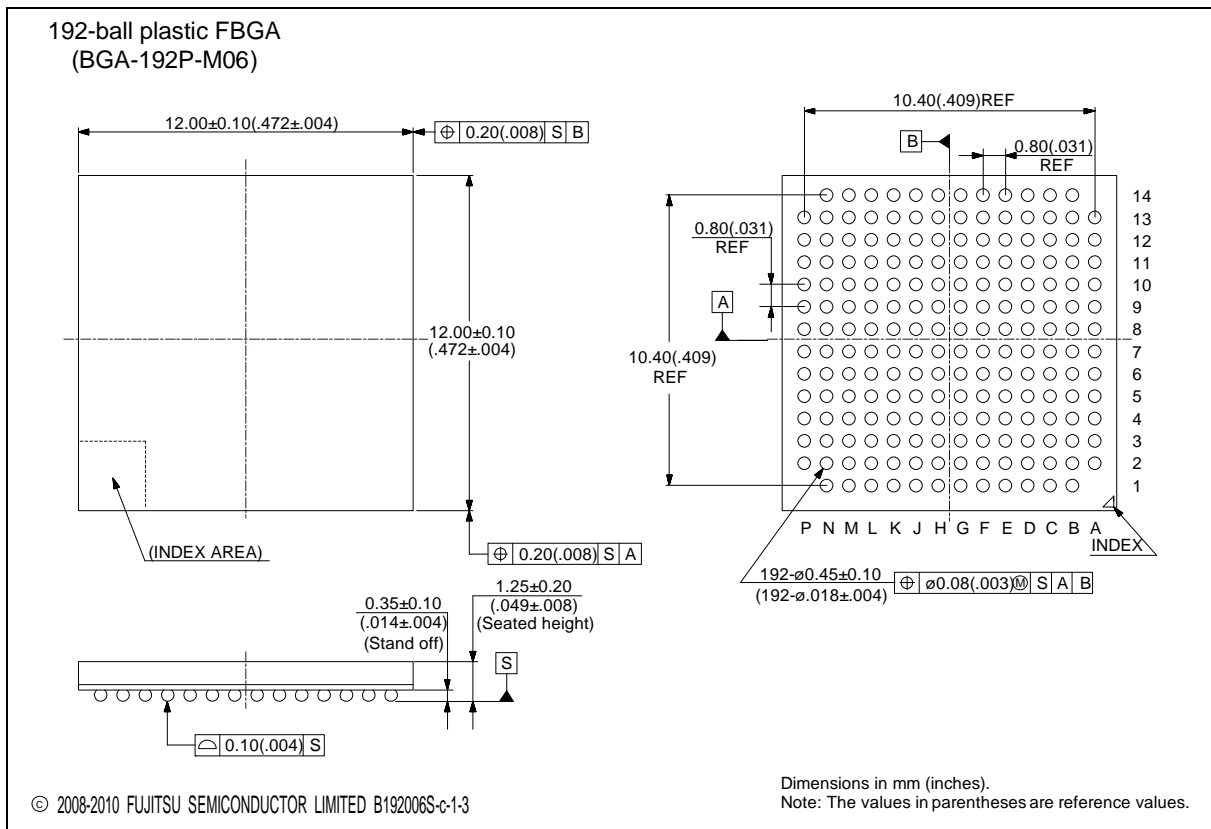

Please check the latest package dimension at the following URL.
<http://edevic.fujitsu.com/package/en-search/>

MB9B410T Series

■ MAJOR CHANGES IN THIS EDITION

A change on a page is indicated by a vertical line drawn on the left side of that page.

Page	Section	Change Results
-	-	Preliminary → Data Sheet
2	■ FEATURES • Multi-function Serial Interface (Max 8channels)	Revised the following description. "4 channels with 16-byte FIFO" →"4 channels with 16steps×9-bit FIFO"
6	■ PRODUCT LINEUP Multi-function Serial Interface (UART/CSIO/LIN/I ² C)	Added the following description. "ch.4 to ch.7: FIFO (16steps × 9-bit) ch.0 to ch.3: No FIFO"
8 to 10	■ PIN ASSIGNMENT	Added the description of "Note".
53	■ I/O CIRCUIT TYPE	Added the following description to "Type H". $I_{OH} = -20.5\text{mA}$, $I_{OL} = 18.5\text{mA}$
60 to 62	■ HANDLING DEVICES	<ul style="list-style-type: none"> Revised the description of "• Power supply pins". Revised the description of "• C pin". Added the description of "• Base Timer".
63	■ BLOCK DIAGRAM	Corrected the figure. <ul style="list-style-type: none"> TIOA: input→ input/output TIOB: output→ input
74	■ ELECTRICAL CHARACTERISTICS 2. Recommended Operating Conditions	<ul style="list-style-type: none"> Corrected the value of "Analog reference voltage (AVRH)". Min: $AV_{SS} \rightarrow 2.7\text{V}$ Added the "Smoothing capacitor (C_S)". Added the footnote.
76	3. DC Characteristics (1) Current Rating	<ul style="list-style-type: none"> Revised the value of "TBD". Revised the unit. Deleted "and estimated values."
79	4. AC Characteristics (1) Main Clock Input Characteristics	<ul style="list-style-type: none"> Revised the value of Input frequency (f_H) at "$V_{CC} \geq 4.5\text{V}$". Max: 50 → 48 Added "Internal operating clock frequency (f_M): Master clock".
81	(4-1) Operating Conditions of Main PLL (In the case of using main clock for input of PLL)	Added "Main PLL clock frequency (f_{CLKPLL})".
	(4-2) Operating Conditions of Main PLL (In the case of using built-in high-speed CR clock for the input clock of the main PLL)	

Page	Section	Change Results
109	5. 12-bit A/D Converter • Electrical characteristics for the A/D converter	<ul style="list-style-type: none"> • Deleted "(Preliminary value)". • Added the Symbol. • Revised the value of "TBD". • Corrected the parameter and value as follows. Full transition voltage → Full-scale transition voltage Min : - 20 → AVRH - 20 Max : + 20 → AVRH + 20 • Revised the maximum value of "Power supply current (analog + digital)": A/D 1unit operation: Typ: 0.47 → 0.57 / Max: 0.62 → 0.72 When A/D stops: Typ: 0.01 → 0.06 • Revised the value of "Reference power supply current (between AVRH to AVSS)" When A/D stops: Typ: 0.01 → 0.06 / Max: 1.6 → 4 • Deleted the following Pin name. <ul style="list-style-type: none"> - "Sampling time" - "Compare clock cycle" - "State transition time to operation permission" - "Analog input capacity" - "Analog input resistance" • Corrected the value of "Compare clock cycle (Tcck)". Max: 10000 → 2000
112	6. Low-voltage Detection Characteristics (2) Interrupt of Low-voltage Detection	Corrected the value of "LVD stabilization wait time (T _{LVDW})". Max: 2240×tcyc → 4032×tcyc
113	7. Flash Memory Write/Erase Characteristics Erase/write cycles and data hold time	Deleted "(targeted value)".

MB9B410T Series

FUJITSU SEMICONDUCTOR LIMITED

Nomura Fudosan Shin-yokohama Bldg. 10-23, Shin-yokohama 2-Chome,
Kohoku-ku Yokohama Kanagawa 222-0033, Japan

Tel: +81-45-415-5858

<http://jp.fujitsu.com/fsl/en/>

For further information please contact:

North and South America

FUJITSU SEMICONDUCTOR AMERICA, INC.
1250 E. Arques Avenue, M/S 333
Sunnyvale, CA 94085-5401, U.S.A.
Tel: +1-408-737-5600 Fax: +1-408-737-5999
<http://us.fujitsu.com/micro/>

Asia Pacific

FUJITSU SEMICONDUCTOR ASIA PTE. LTD.
151 Lorong Chuan,
#05-08 New Tech Park 556741 Singapore
Tel : +65-6281-0770 Fax : +65-6281-0220
<http://sg.fujitsu.com/semiconductor/>

Europe

FUJITSU SEMICONDUCTOR EUROPE GmbH
Pittlerstrasse 47, 63225 Langen, Germany
Tel: +49-6103-690-0 Fax: +49-6103-690-122
<http://emea.fujitsu.com/semiconductor/>

FUJITSU SEMICONDUCTOR SHANGHAI CO., LTD.

30F, Kerry Parkside, 1155 Fang Dian Road,
Pudong District, Shanghai 201204, China
Tel : +86-21-6146-3688 Fax : +86-21-6146-3660
<http://cn.fujitsu.com/fss/>

Korea

FUJITSU SEMICONDUCTOR KOREA LTD.
902 Kosmo Tower Building, 1002 Daechi-Dong,
Gangnam-Gu, Seoul 135-280, Republic of Korea
Tel: +82-2-3484-7100 Fax: +82-2-3484-7111
<http://kr.fujitsu.com/fsk/>

FUJITSU SEMICONDUCTOR PACIFIC ASIA LTD.

2/F, Green 18 Building, Hong Kong Science Park,
Shatin, N.T., Hong Kong
Tel : +852-2736-3232 Fax : +852-2314-4207
<http://cn.fujitsu.com/fsp/>

Specifications are subject to change without notice. For further information please contact each office.

All Rights Reserved.

The contents of this document are subject to change without notice.

Customers are advised to consult with sales representatives before ordering.

The information, such as descriptions of function and application circuit examples, in this document are presented solely for the purpose of reference to show examples of operations and uses of FUJITSU SEMICONDUCTOR device; FUJITSU SEMICONDUCTOR does not warrant proper operation of the device with respect to use based on such information. When you develop equipment incorporating the device based on such information, you must assume any responsibility arising out of such use of the information.

FUJITSU SEMICONDUCTOR assumes no liability for any damages whatsoever arising out of the use of the information. Any information in this document, including descriptions of function and schematic diagrams, shall not be construed as license of the use or exercise of any intellectual property right, such as patent right or copyright, or any other right of FUJITSU SEMICONDUCTOR or any third party or does FUJITSU SEMICONDUCTOR warrant non-infringement of any third-party's intellectual property right or other right by using such information. FUJITSU SEMICONDUCTOR assumes no liability for any infringement of the intellectual property rights or other rights of third parties which would result from the use of information contained herein.

The products described in this document are designed, developed and manufactured as contemplated for general use, including without limitation, ordinary industrial use, general office use, personal use, and household use, but are not designed, developed and manufactured as contemplated (1) for use accompanying fatal risks or dangers that, unless extremely high safety is secured, could have a serious effect to the public, and could lead directly to death, personal injury, severe physical damage or other loss (i.e., nuclear reaction control in nuclear facility, aircraft flight control, air traffic control, mass transport control, medical life support system, missile launch control in weapon system), or (2) for use requiring extremely high reliability (i.e., submersible repeater and artificial satellite).

Please note that FUJITSU SEMICONDUCTOR will not be liable against you and/or any third party for any claims or damages arising in connection with above-mentioned uses of the products.

Any semiconductor devices have an inherent chance of failure. You must protect against injury, damage or loss from such failures by incorporating safety design measures into your facility and equipment such as redundancy, fire protection, and prevention of over-current levels and other abnormal operating conditions.

Exportation/release of any products described in this document may require necessary procedures in accordance with the regulations of the Foreign Exchange and Foreign Trade Control Law of Japan and/or US export control laws.

The company names and brand names herein are the trademarks or registered trademarks of their respective owners.