

32-bit Microcontroller
FR Family FR81S
MB91520 Series

**MB91F522B/D/F/J/K/L, MB91F523B/D/F/J/K/L, MB91F524B/D/F/J/K/L,
MB91F525B/D/F/J/K/L, MB91F526B/D/F/J/K/L***

■ **DESCRIPTION**

The MB91520 series is a Fujitsu Semiconductor 32-bit microcontroller designed for automotive devices. This series contains the FR81S CPU which is compatible with the FR family.

Note: FR, the abbreviation of FUJITSU RISC controller, is a line of products of Fujitsu Semiconductor Limited.

*:This series is a composition of the kind that adds HB/JB/KB/LB/SB/UB/WB/YB to the end of the above-mentioned each name of articles of presence, According to Presence of sub-clock, CSV initial value and LVD initial value.

Please see "■ ORDERING INFORMATION" for details.

FUJITSU SEMICONDUCTOR provides information facilitating product development via the following website. The website contains information useful for customers.

<http://edevice.fujitsu.com/micom/en-support/>

■ FEATURES

● FR81S CPU Core

- 32-bit RISC, load/store architecture, pipeline 5-stage structure
- Maximum operating frequency: 80 MHz (Source oscillation = 4.0 MHz and 20 multiplied (PLL clock multiplication system))
- General-purpose register : 32 bits × 16 sets
- 16-bit fixed length instructions (basic instruction), 1 instruction per cycle
- Instructions appropriate to embedded applications
 - Memory-to-memory transfer instruction
 - Bit processing instruction
 - Barrel shift order etc.
- High-level language support instructions
- Function entry/exit instructions
- Register content multi-load and store instructions
- Bit search instructions
 - Logical 1 detection, 0 detection, and change-point detection
- Branch instructions with delay slot
 - Overhead reduction during branch process
- Register interlock function
 - Easy assembler writing
- The support at the built-in / instruction level of the multiplier
 - Signed 32-bit multiplication: 5 cycles
 - Signed 16-bit multiplication: 3 cycles
- Interrupt (PC/PS saving)
 - 6 cycles (16 priority levels)
- The Harvard architecture allows simultaneous execution of program and data access.
- Instruction compatibility with the FR Family
- Built-in memory protection function (MPU)
 - Eight protection areas can be specified commonly for instructions and the data.
 - Control access privilege in both privilege mode and user mode.
- Built-in FPU (floating point arithmetic)
 - IEEE754 compliant
 - Floating-point register 32-bit × 16 sets

● Peripheral functions

- Clock generation (equipped with SSCG function)
 - Main oscillation (4MHz to 16MHz)
 - Sub oscillation (32kHz to 100kHz) or none sub oscillation
 - PLL multiplication rate : 1 to 20 times
- Built-in program flash memory capacity
 - MB91F522:256+64KB
 - MB91F523:384+64KB
 - MB91F524:512+64KB
 - MB91F525:768+64KB
 - MB91F526:1024+64KB
- Flash memory for built-in data (WorkFlash) 64KB
- Built-in RAM capacity
 - Main RAM
 - MB91F522:48KB
 - MB91F523:48KB
 - MB91F524:64KB
 - MB91F525:96KB
 - MB91F526:128KB
 - Backup RAM 8KB

- General-purpose ports:
 - MB91F52xB 44 sets (No sub oscillation), 42 sets (sub oscillation)
 - MB91F52xD 56 sets (No sub oscillation), 54 sets (sub oscillation)
 - MB91F52xF 76 sets (No sub oscillation), 74 sets (sub oscillation)
 - MB91F52xJ 96 sets (No sub oscillation), 94 sets (sub oscillation)
 - MB91F52xK 120 sets (No sub oscillation), 118 sets (sub oscillation)
 - MB91F52xL 152 sets (No sub oscillation), 150 sets (sub oscillation)
 - Included I²C open drain corresponding ports:16 sets
- External bus interface
 - 22-bit address, 16-bit data
- DMA Controller
 - Up to 16 channels can be started simultaneously.
 - 2 transfer factors (Internal peripheral request and software)
- A/D converter (successive approximation type)
 - 12-bit resolution : Max.48ch (32ch+16ch)
 - Conversion time : 1μs
- D/A converter (R-2R type)
 - 8-bit resolution : 2ch
- External interrupt input: 8 channels × 2 units total 16 channels
 - Level ("H" / "L"), or edge detection (rising or falling) enabled
- Multi-function serial communication (built-in transmission/reception FIFO memory) : Max.12 channels
 - 5V tolerant input: 4 channels ch.6, ch.8, ch.9, ch.11 Automotive input
 - < UART (Asynchronous serial interface) >
 - Full-duplex double buffering system, 64-step transmission FIFO memory, 64-step reception FIFO memory
 - Parity or no parity is selectable.
 - Built-in dedicated baud rate generator
 - An external clock can be used as the transfer clock
 - Parity, frame, and overrun error detection functions provided
 - DMA transfer support
 - <CSIO (Synchronous serial interface) >
 - Full-duplex double buffering system, 64-step transmission FIFO memory, 64-step reception FIFO memory
 - SPI supported; master and slave systems supported; 5 to 16, 20, 24, 32-bit data length can be set.
 - Built-in dedicated baud rate generator (Master operation)
 - An external clock can be entered. (Slave operation)
 - Overrun error detection function is provided
 - DMA transfer support
 - Serial chip select SPI function
 - <LIN (Asynchronous Serial Interface for LIN) >
 - Full-duplex double buffering system, 64-step transmission FIFO memory, 64-step reception FIFO memory
 - LIN protocol revision 2.1 supported
 - Master and slave systems supported
 - Framing error and overrun error detection
 - LIN synch break generation and detection; LIN synch delimiter generation
 - Built-in dedicated baud rate generator
 - An external clock can be adjusted by the reload counter
 - DMA transfer support
 - Hard assist function
 - < I²C >
 - 2 channels ch.3 , ch.4 Standard mode/high-speed mode supported.
 - 6 channels ch.5 to ch.8, ch.10, ch.11 Standard mode supported.
 - Full-duplex double buffering system, 64-step transmission FIFO memory, 64-step reception FIFO memory
 - Standard mode (Max. 100kbps) / high-speed mode (Max. 400kbps) supported
 - DMA transfer supported (for transmission only)

MB91520 Series

- CAN Controller (CAN) : 3 channels
 - Transfer speed : Up to 1Mbps
 - 128-transmission/reception message buffering : 1 channel (ch.0),
64-transmission/reception message buffering : 2 channels (ch.1 and ch.2)
- PPG: 16-bit × Max. 48 channels
 - LED drive output 4 channels 11ch to 14ch
 - Reload timer : 16-bit × Max.8 channels
 - Free-run timer :
 - 16-bit × 3 channels
 - 32-bit × Max 3 channels
- Input capture :
 - 16-bit × 4 channels (linked to the free-run timer)
 - 32-bit × Max 6 channels (linked to the free-run timer)
- Output compare :
 - 16-bit × 6 channels (linked to the free-run timer)
 - 32-bit × Max 6 channels (linked to the free-run timer)
- Waveform generator : 6 channels
- Up/Down counter
 - 8/16-bit Up/Down counter × 2 channels
- Real-time clock (RTC) (for day, hours, minutes, seconds)
 - Main or sub oscillation frequency can be selected for the operation clock
- Calibration: Real-time clock (RTC) of the subclock drive
 - The main clock to sub clock ratio can be corrected by setting the real-time clock prescaler
- Clock Supervisor
 - Monitoring abnormality (by damaged quartz, etc.) of suboscillation (32kHz) (dual clock products) of the outside and main oscillation (4 MHz)
 - When abnormality is detected, it switches to the CR clock.
 - Initial value ON/OFF can be selected by the part number.
- Base timer : Max.2 channels
 - 16-bit timer
 - Any of four PWM/PPG/PWC/reload timer functions can be selected and used
 - A 32-bit timer can be used in 2 channels of cascade mode
- CRC generation
- Watchdog timer
 - Hardware watchdog
 - Software watchdog (possible to set the valid range for counter clearing)
- NMI (non-maskable interrupt)
- Interrupt controller
- Interrupt request batch read
 - The interrupt existence from two or more peripherals can be read by a series of register.
- I/O relocation
 - Peripheral function pins can be reassigned.
- Low-power consumption mode
 - Sleep / Stop / Watch / Sub RUN mode
 - Stop (power shutdown) / Watch (power shutdown) mode
- Power-on reset
- Low-voltage detection reset (independently monitor the external power supply and the internal power supply)
 - The external power supply can select initial value ON/OFF by the part number.
- Device Package : LQFP-176/144/120/100/80/64
- CMOS 90nm Technology
- Power supplies
 - 5V Power supply
 - The internal 1.2V is generated from 5V with the voltage step-down circuit.

■ PRODUCT LINEUP

● Product lineup comparison 64pins

	MB91F522B	MB91F523B	MB91F524B	MB91F525B	MB91F526B
System Clock	On chip PLL Clock multiple method				
Minimum instruction execution time	12.5ns (80MHz)				
Flash Capacity (Program)	(256+64)KB	(384+64)KB	(512+64)KB	(768+64)KB	(1024+64)KB
Flash Capacity (Data)	64KB				
RAM Capacity	(48+8)KB		(64+8)KB	(96+8)KB	(128+8)KB
External BUS I/F (22address/16data/4cs)	None				
DMA Transfer	16ch				
16-bit Base Timer	None				
Free-run Timer	16bit×3ch 32bit×1ch				
Input capture	16bit×4ch 32bit×5ch				
Output Compare	16bit×6ch 32bit×4ch				
16-bit Reload Timer	7ch				
PPG	16bit×21ch				
Up/down Counter	2ch				
Clock Supervisor	Yes				
External Interrupt	8ch×2units				
A/D converter	12bit×13ch (1unit) 12bit×13ch (1unit)				
D/A converter (8bit)	1ch				
Multi-Function Serial Interface	8ch				
CAN	64msg×2ch/128msg×1ch				
Hardware Watchdog Timer	Yes				
CRC Formation	Yes				
Low-voltage detection reset	Yes				
Flash Security	Yes				
ECC Flash/WorkFlash	Yes				
ECC RAM	Yes				
Memory Protection Function (MPU)	Yes				
Floating point arithmetic (FPU)	Yes				
Real Time Clock (RTC)	Yes				
General-purpose port (#GPIOs)	44 ports				
SSCG	Yes				
Sub clock	Yes				
CR oscillator	Yes				
OCD (On Chip Debug)	Yes				
TPU (Timing Protection Unit)	Yes				
Key code register	Yes				
Waveform generator	6ch				
NMI request function	Yes				
Operation guaranteed temperature (T _A)	-40°C to +125°C				
Power supply	2.7V to 5.5V				
Package	LQFP-64				

MB91520 Series

● Product lineup comparison 80pins

	MB91F522D	MB91F523D	MB91F524D	MB91F525D	MB91F526D
System Clock	On chip PLL Clock multiple method				
Minimum instruction execution time	12.5ns (80MHz)				
Flash Capacity (Program)	(256+64)KB	(384+64)KB	(512+64)KB	(768+64)KB	(1024+64)KB
Flash Capacity (Data)	64KB				
RAM Capacity	(48+8)KB		(64+8)KB	(96+8)KB	(128+8)KB
External BUS I/F (22address/16data/4cs)	None				
DMA Transfer	16ch				
16-bit Base Timer	1ch				
Free-run Timer	16bit×3ch 32bit×2ch				
Input capture	16bit×4ch 32bit×5ch				
Output Compare	16bit×6ch 32bit×4ch				
16-bit Reload Timer	7ch				
PPG	16bit×27ch				
Up/down Counter	2ch				
Clock Supervisor	Yes				
External Interrupt	8ch×2units				
A/D converter	12bit×16ch (1unit) 12bit×16ch (1unit)				
D/A converter (8bit)	1ch				
Multi-Function Serial Interface	9ch				
CAN	64msg×2ch/128msg×1ch				
Hardware Watchdog Timer	Yes				
CRC Formation	Yes				
Low-voltage detection reset	Yes				
Flash Security	Yes				
ECC Flash/WorkFlash	Yes				
ECC RAM	Yes				
Memory Protection Function (MPU)	Yes				
Floating point arithmetic (FPU)	Yes				
Real Time Clock (RTC)	Yes				
General-purpose port (#GPIOs)	56 ports				
SSCG	Yes				
Sub clock	Yes				
CR oscillator	Yes				
NMI request function	Yes				
OCD (On Chip Debug)	Yes				
TPU (Timing Protection Unit)	Yes				
Key code register	Yes				
Waveform generator	6ch				
Operation guaranteed temperature (T _A)	-40°C to +125°C				
Power supply	2.7V to 5.5V				
Package	LQFP-80				

MB91520 Series

● Product lineup comparison 100pins

	MB91F522F	MB91F523F	MB91F524F	MB91F525F	MB91F526F
System Clock	On chip PLL Clock multiple method				
Minimum instruction execution time	12.5ns (80MHz)				
Flash Capacity (Program)	(256+64)KB	(384+64)KB	(512+64)KB	(768+64)KB	(1024+64)KB
Flash Capacity (Data)	64KB				
RAM Capacity	(48+8)KB		(64+8)KB	(96+8)KB	(128+8)KB
External BUS I/F (22address/16data/4cs)	None				
DMA Transfer	16ch				
16-bit Base Timer	1ch				
Free-run Timer	16bit×3ch 32bit×3ch				
Input capture	16bit×4ch 32bit×6ch				
Output Compare	16bit×6ch 32bit×6ch				
16-bit Reload Timer	8ch				
PPG	16bit×34ch				
Up/down Counter	2ch				
Clock Supervisor	Yes				
External Interrupt	8ch×2units				
A/D converter	12bit×21ch (1unit) 12bit×16ch (1unit)				
D/A converter (8bit)	2ch				
Multi-Function Serial Interface	12ch				
CAN	64msg×2ch/128msg×1ch				
Hardware Watchdog Timer	Yes				
CRC Formation	Yes				
Low-voltage detection reset	Yes				
Flash Security	Yes				
ECC Flash/WorkFlash	Yes				
ECC RAM	Yes				
Memory Protection Function (MPU)	Yes				
Floating point arithmetic (FPU)	Yes				
Real Time Clock (RTC)	Yes				
General-purpose port (#GPIOs)	76 ports				
SSCG	Yes				
Sub clock	Yes				
CR oscillator	Yes				
NMI request function	Yes				
OCD (On Chip Debug)	Yes				
TPU (Timing Protection Unit)	Yes				
Key code register	Yes				
Waveform generator	6ch				
Operation guaranteed temperature (T _A)	-40°C to +125°C				
Power supply	2.7V to 5.5V				
Package	LQFP-100				

MB91520 Series

● Product lineup comparison 120pins

	MB91F522J	MB91F523J	MB91F524J	MB91F525J	MB91F526J
System Clock	On chip PLL Clock multiple method				
Minimum instruction execution time	12.5ns (80MHz)				
Flash Capacity (Program)	(256+64)KB	(384+64)KB	(512+64)KB	(768+64)KB	(1024+64)KB
Flash Capacity (Data)	64KB				
RAM Capacity	(48+8)KB		(64+8)KB	(96+8)KB	(128+8)KB
External BUS I/F (22address/16data/4cs)	None				
DMA Transfer	16ch				
16-bit Base Timer	2ch				
Free-run Timer	16bit×3ch 32bit×3ch				
Input capture	16bit×4ch 32bit×6ch				
Output Compare	16bit×6ch 32bit×6ch				
16-bit Reload Timer	8ch				
PPG	16bit×38ch				
Up/down Counter	2ch				
Clock Supervisor	Yes				
External Interrupt	8ch×2units				
A/D converter	12bit×26ch (1unit) 12bit×16ch (1unit)				
D/A converter (8bit)	2ch				
Multi-Function Serial Interface	12ch				
CAN	64msg×2ch/128msg×1ch				
Hardware Watchdog Timer	Yes				
CRC Formation	Yes				
Low-voltage detection reset	Yes				
Flash Security	Yes				
ECC Flash/WorkFlash	Yes				
ECC RAM	Yes				
Memory Protection Function (MPU)	Yes				
Floating point arithmetic (FPU)	Yes				
Real Time Clock (RTC)	Yes				
General-purpose port (#GPIOs)	96 ports				
SSCG	Yes				
Sub clock	Yes				
CR oscillator	Yes				
NMI request function	Yes				
OCD (On Chip Debug)	Yes				
TPU (Timing Protection Unit)	Yes				
Key code register	Yes				
Waveform generator	6ch				
Operation guaranteed temperature (T _A)	-40°C to +125°C				
Power supply	2.7V to 5.5V				
Package	LQFP-120				

MB91520 Series

● Product lineup comparison 144pins

	MB91F522K	MB91F523K	MB91F524K	MB91F525K	MB91F526K
System Clock	On chip PLL Clock multiple method				
Minimum instruction execution time	12.5ns (80MHz)				
Flash Capacity (Program)	(256+64)KB	(384+64)KB	(512+64)KB	(768+64)KB	(1024+64)KB
Flash Capacity (Data)	64KB				
RAM Capacity	(48+8)KB		(64+8)KB	(96+8)KB	(128+8)KB
External BUS I/F (22address/16data/4cs)	Yes				
DMA Transfer	16ch				
16-bit Base Timer	2ch				
Free-run Timer	16bit×3ch 32bit×3ch				
Input capture	16bit×4ch 32bit×6ch				
Output Compare	16bit×6ch 32bit×6ch				
16-bit Reload Timer	8ch				
PPG	16bit×44ch				
Up/down Counter	2ch				
Clock Supervisor	Yes				
External Interrupt	8ch×2units				
A/D converter	12bit×32ch (1unit) 12bit×16ch (1unit)				
D/A converter (8bit)	2ch				
Multi-Function Serial Interface	12ch				
CAN	64msg×2ch/128msg×1ch				
Hardware Watchdog Timer	Yes				
CRC Formation	Yes				
Low-voltage detection reset	Yes				
Flash Security	Yes				
ECC Flash/WorkFlash	Yes				
ECC RAM	Yes				
Memory Protection Function (MPU)	Yes				
Floating point arithmetic (FPU)	Yes				
Real Time Clock (RTC)	Yes				
General-purpose port (#GPIOs)	120 ports				
SSCG	Yes				
Sub clock	Yes				
CR oscillator	Yes				
NMI request function	Yes				
OCD (On Chip Debug)	Yes				
TPU (Timing Protection Unit)	Yes				
Key code register	Yes				
Waveform generator	6ch				
Operation guaranteed temperature (T _A)	-40°C to +125°C				
Power supply	2.7V to 5.5V				
Package	LQFP-144				

MB91520 Series

● Product lineup comparison 176pins

	MB91F522L	MB91F523L	MB91F524L	MB91F525L	MB91F526L
System Clock	On chip PLL Clock multiple method				
Minimum instruction execution time	12.5ns (80MHz)				
Flash Capacity (Program)	(256+64)KB	(384+64)KB	(512+64)KB	(768+64)KB	(1024+64)KB
Flash Capacity (Data)	64KB				
RAM Capacity	(48+8)KB		(64+8)KB	(96+8)KB	(128+8)KB
External BUS I/F (22address/16data/4cs)	Yes				
DMA Transfer	16ch				
16-bit Base Timer	2ch				
Free-run Timer	16bit×3ch 32bit×3ch				
Input capture	16bit×4ch 32bit×6ch				
Output Compare	16bit×6ch 32bit×6ch				
16-bit Reload Timer	8ch				
PPG	16bit×48ch				
Up/down Counter	2ch				
Clock Supervisor	Yes				
External Interrupt	8ch×2units				
A/D converter	12bit×32ch (1unit) 12bit×16ch (1unit)				
D/A converter (8bit)	2ch				
Multi-Function Serial Interface	12ch				
CAN	64msg×2ch/128msg×1ch				
Hardware Watchdog Timer	Yes				
CRC Formation	Yes				
Low-voltage detection reset	Yes				
Flash Security	Yes				
ECC Flash/WorkFlash	Yes				
ECC RAM	Yes				
Memory Protection Function (MPU)	Yes				
Floating point arithmetic (FPU)	Yes				
Real Time Clock (RTC)	Yes				
General-purpose port (#GPIOs)	152 ports				
SSCG	Yes				
Sub clock	Yes				
CR oscillator	Yes				
NMI request function	Yes				
OCD (On Chip Debug)	Yes				
TPU (Timing Protection Unit)	Yes				
Key code register	Yes				
Waveform generator	6ch				
Operation guaranteed temperature (T _A)	-40°C to +125°C				
Power supply	2.7V to 5.5V				
Package	LQFP-176				

● Table for clock supervisor and external low voltage detection reset initial value ON/OFF

Clock	CSV Initial value	LVD Initial value	Function
single	ON	ON	S
		OFF	U
	OFF	ON	H
		OFF	K
Dual	ON	ON	W
		OFF	Y
	OFF	ON	J
		OFF	L

MB91F52X□△○

| | | → Revision: B
 | | | → Function: See the table for clock supervisor and external
 | | | low voltage detection reset initial value ON/OFF.
 | | | → PKG Type: B 64 pin
 | | | D 80 pin
 | | | F 100 pin
 | | | J 120 pin
 | | | K 144 pin
 | | | L 176 pin
 | | | → Memory Size: 2 256 KB
 | | | 3 384 KB
 | | | 4 512 KB
 | | | 5 768 KB
 | | | 6 1 MB

MB91520 Series

■ PIN ASSIGNMENT

● MB91F52xB

MB91F522B, MB91F523B, MB91F524B, MB91F525B, MB91F526B

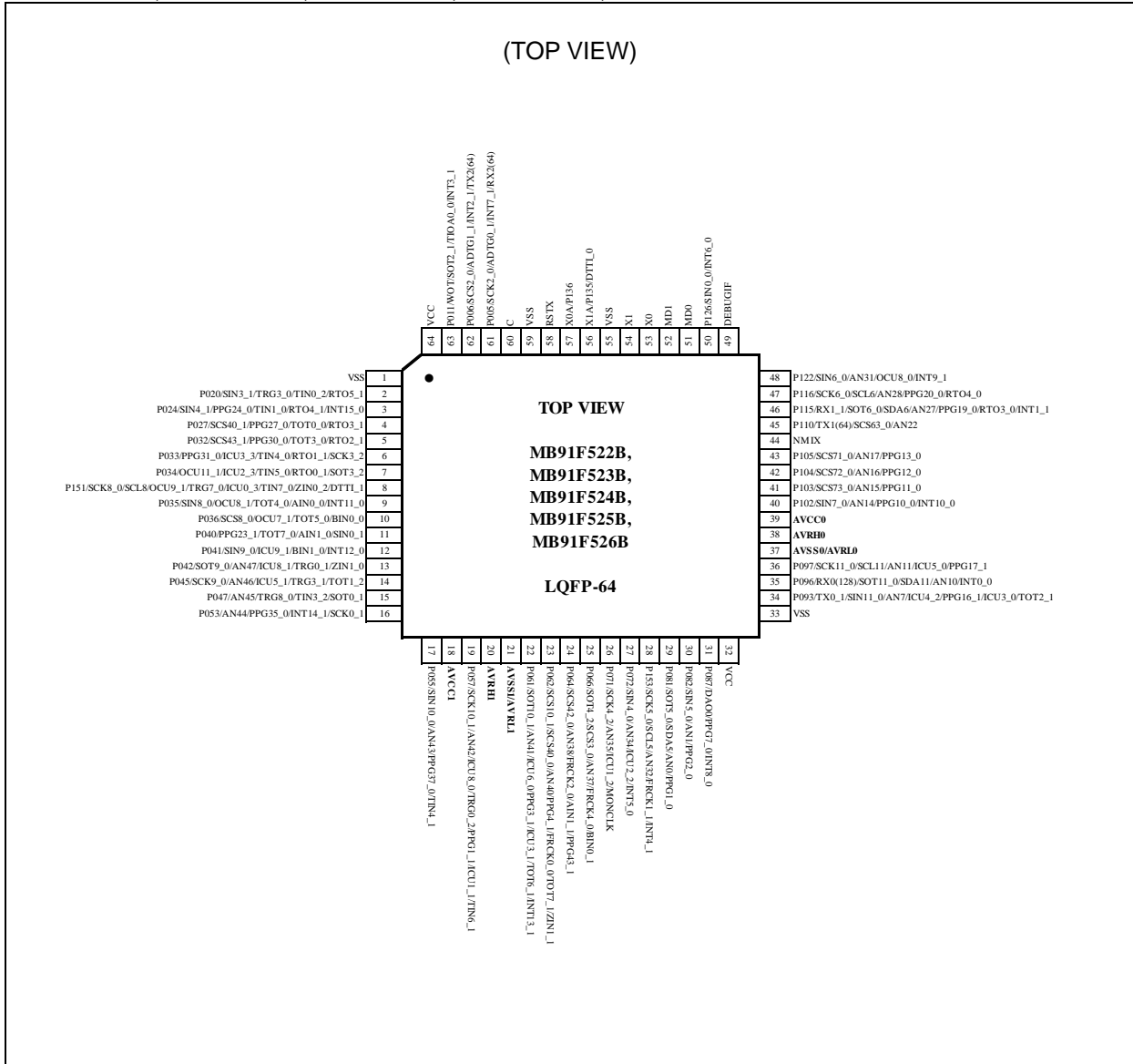

● MB91F52xD

MB91F522D, MB91F523D, MB91F524D, MB91F525D, MB91F526D

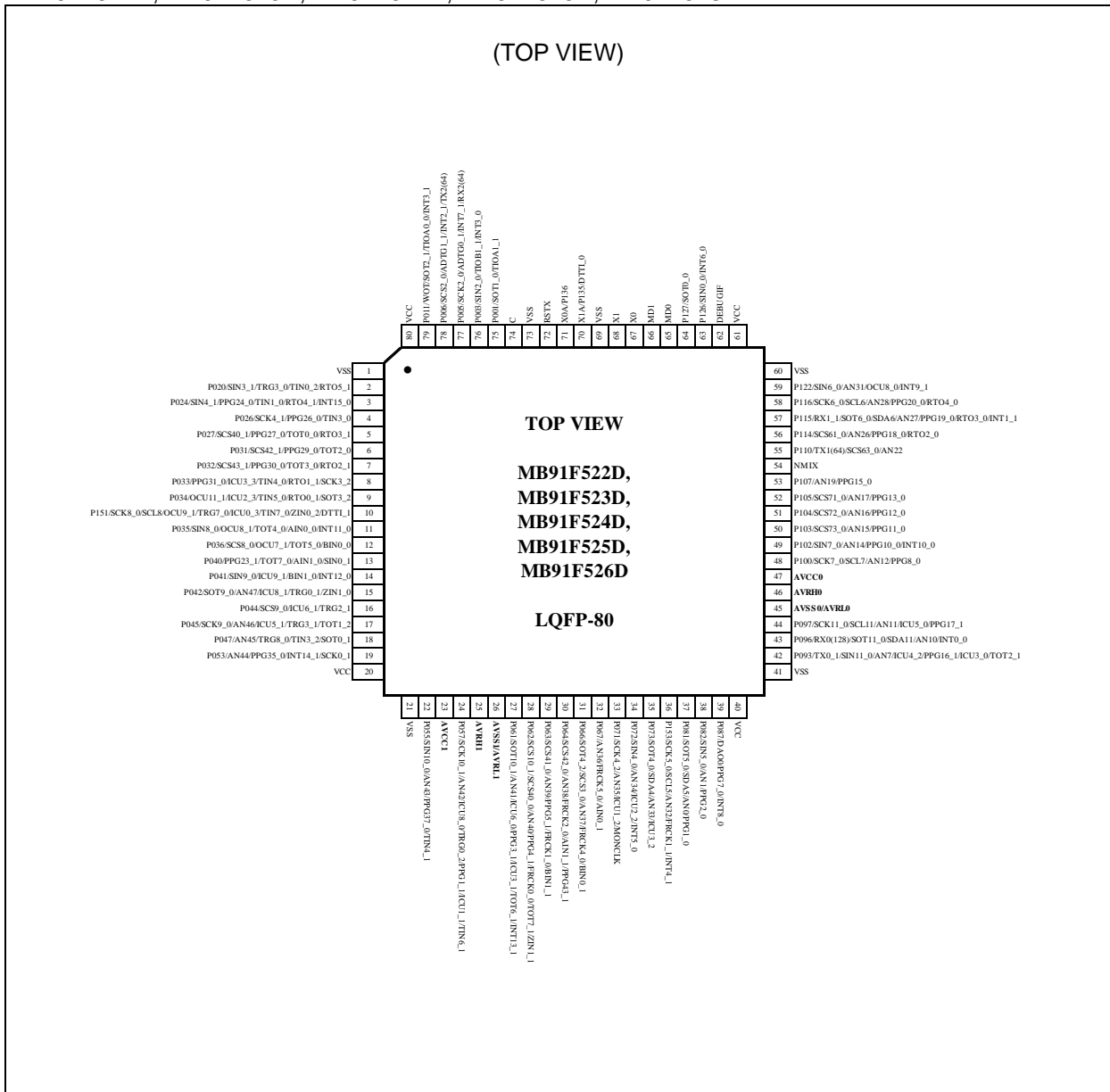

MB91520 Series

● MB91F52xF

MB91F522F, MB91F523F, MB91F524F, MB91F525F, MB91F526F

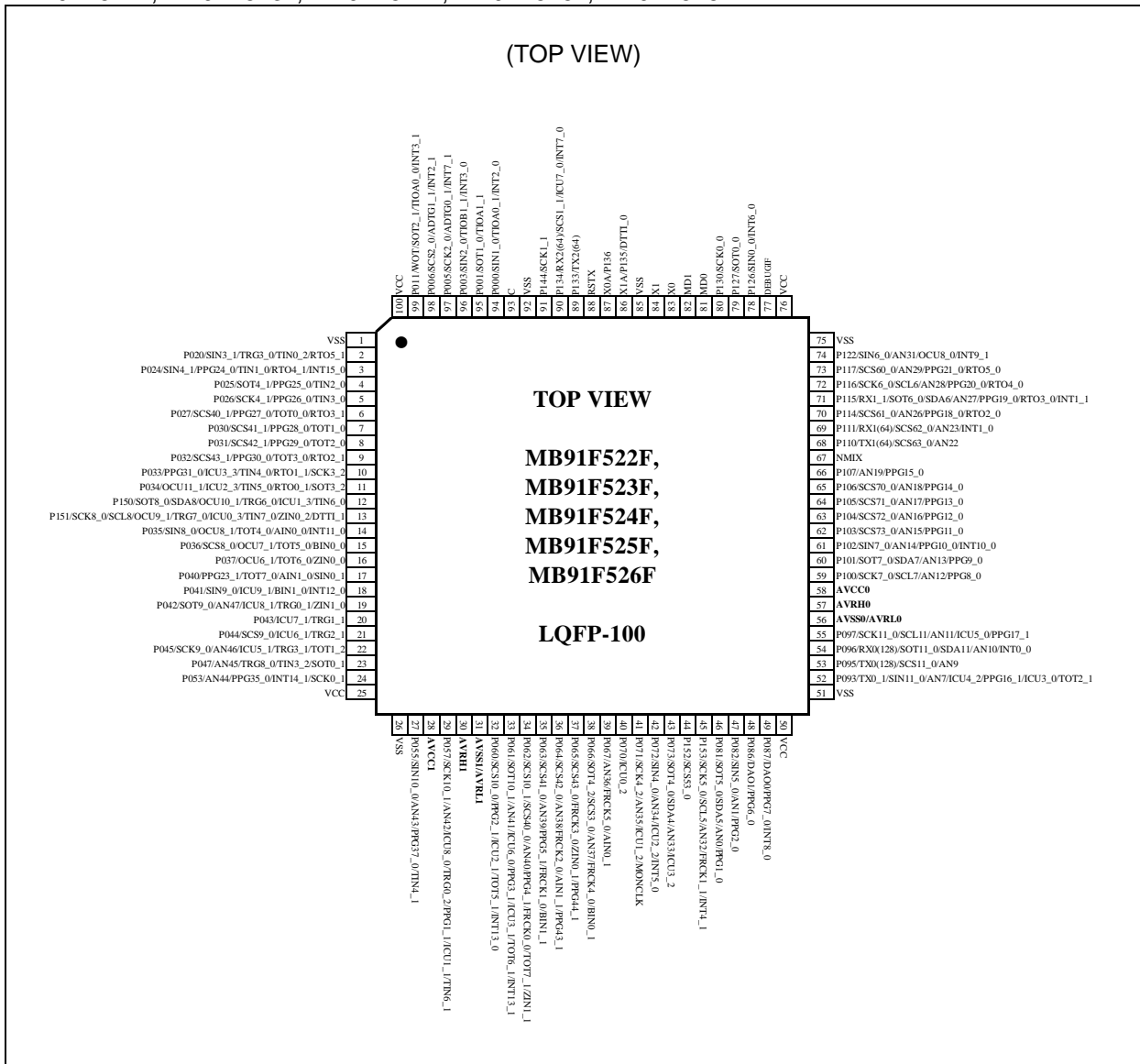

● MB91F52xJ

MB91F522J, MB91F523J, MB91F524J, MB91F525J, MB91F526J

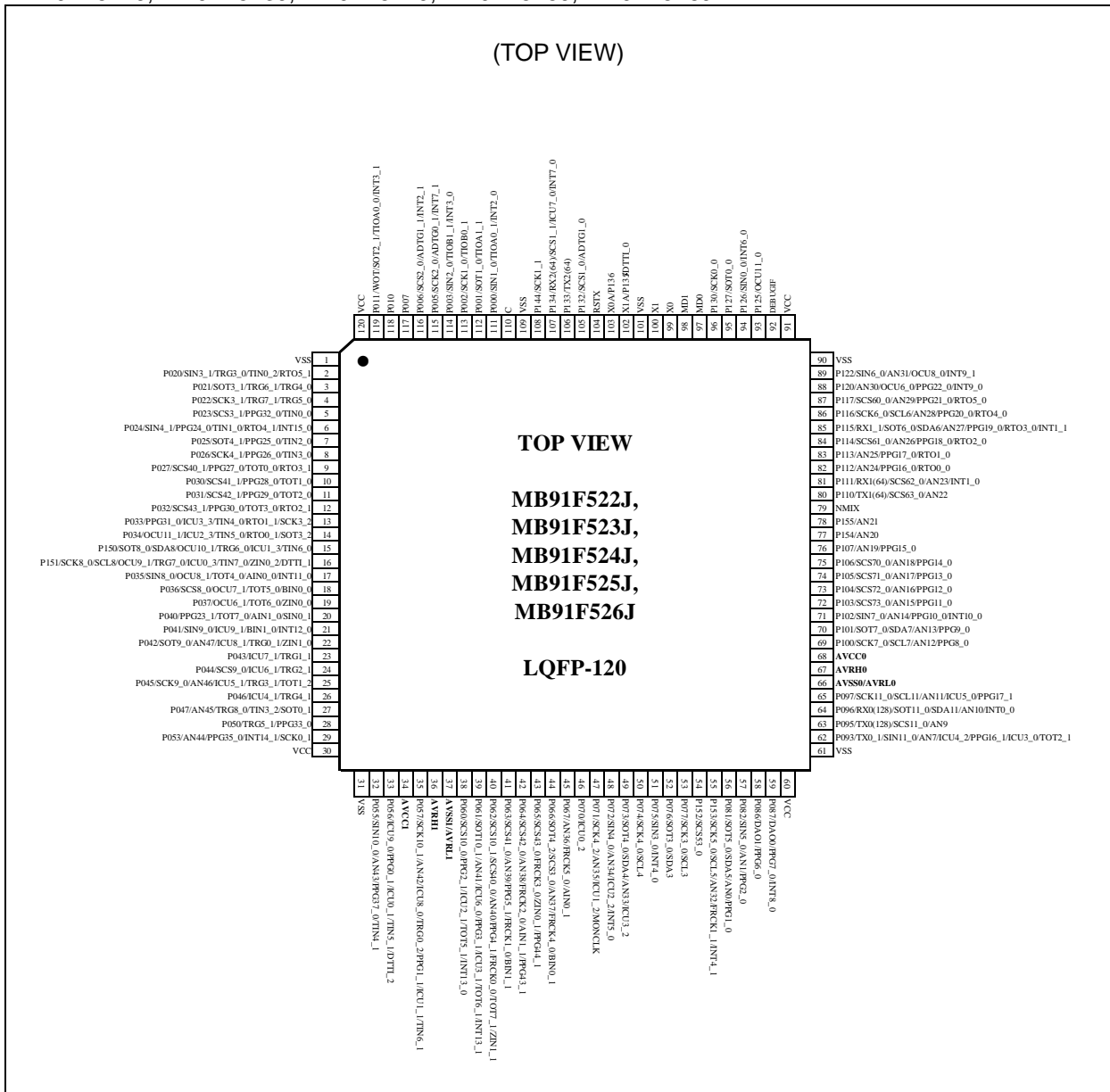

MB91520 Series

● MB91F52xK

MB91F522K, MB91F523K, MB91F524K, MB91F525K, MB91F526K

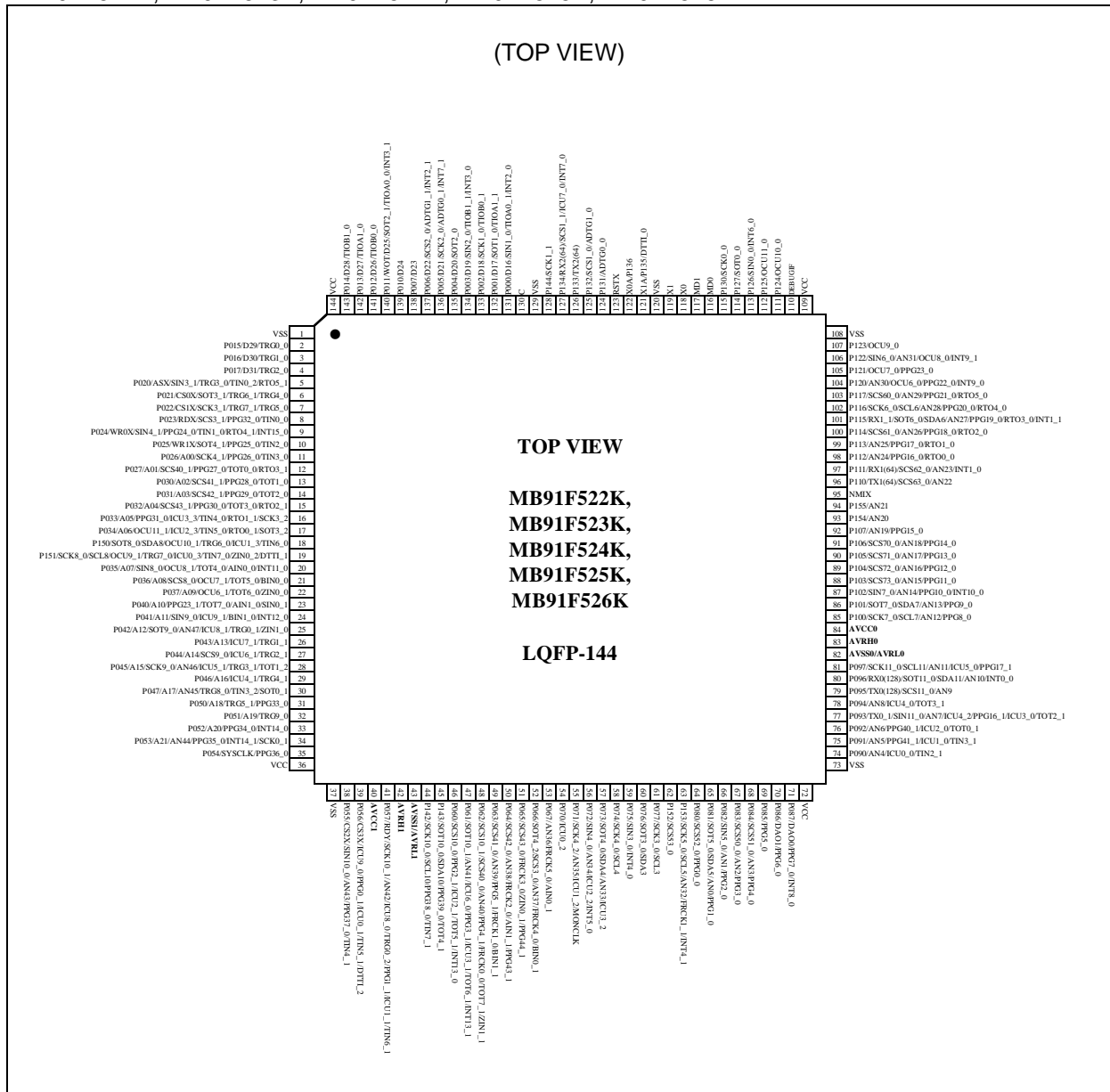

● MB91F52xL

MB91F522L, MB91F523L, MB91F524L, MB91F525L, MB91F526L

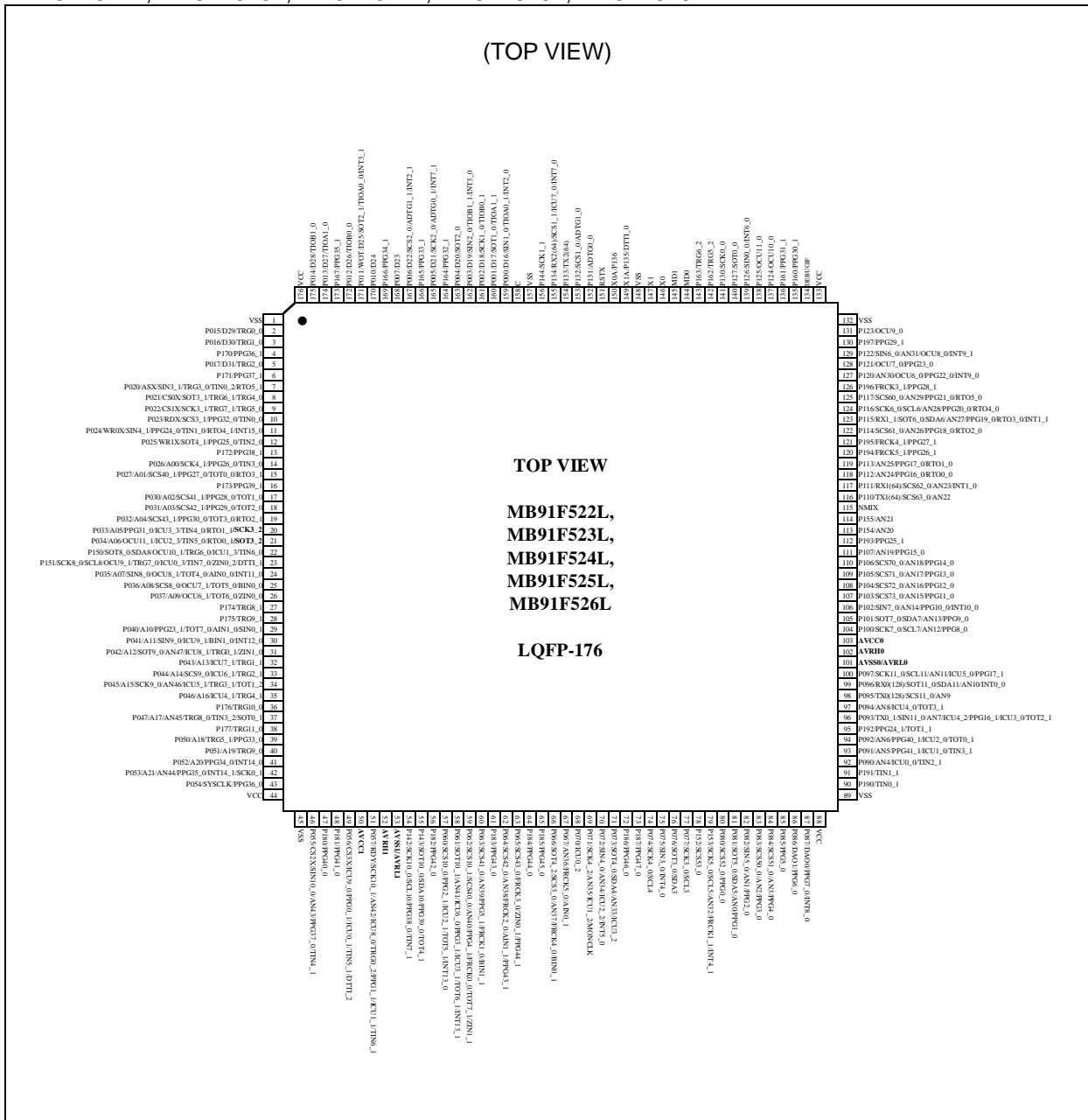

MB91520 Series

■ PIN DESCRIPTION

Pin no.						Pin Name	Polarity	I/O circuit types*1	Function*2
64	80	100	120	144	176				
-	-	-	-	2	2	P015	-	A	General-purpose I/O port
						D29	-		External bus data bit29 I/O (0)
						TRG0_0	-		PPG trigger 0 input (0)
-	-	-	-	3	3	P016	-	A	General-purpose I/O port
						D30	-		External bus data bit30 I/O (0)
						TRG1_0	-		PPG trigger 1 input (0)
-	-	-	-	-	4	P170	-	A	General-purpose I/O port
						PPG36_1	-		PPG ch.36 output (1)
-	-	-	-	4	5	P017	-	A	General-purpose I/O port
						D31	-		External bus data bit31 I/O (0)
						TRG2_0	-		PPG trigger 2 input (0)
-	-	-	-	-	6	P171	-	A	General-purpose I/O port
						PPG37_1	-		PPG ch.37 output (1)
2	2	2	2	5	7	P020	-	F	General-purpose I/O port
						ASX	-		External bus/Address strobe output
						SIN3_1	-		Multi-function serial ch.3 serial data input (1)
						TRG3_0	-		PPG trigger 3 input (0)
						TIN0_2	-		Reload timer ch.0 event input (2)
						RTO5_1	-		Waveform generator ch.5 output pin (1)
-	-	-	3	6	8	P021	-	A	General-purpose I/O port
						CS0X	-		External bus chip select 0 output
						SOT3_1	-		Multi-function serial ch.3 serial data output (1)
						TRG6_1	-		PPG trigger 6 input (1)
						TRG4_0	-		PPG trigger 4 input (0)
-	-	-	4	7	9	P022	-	F	General-purpose I/O port
						CS1X	-		External bus chip select 1 output
						SCK3_1	-		Multi-function serial ch.3 clock I/O (1)
						TRG7_1	-		PPG trigger 7 input (1)
						TRG5_0	-		PPG trigger 5 input (0)
-	-	-	5	8	10	P023	-	A	General-purpose I/O port
						RDX	-		External bus/Read strobe output
						SCS3_1	-		Serial chip select 3 output (1)
						PPG32_0	-		PPG ch.32 output (0)
						TIN0_0	-		Reload timer ch.0 event input (0)
3	3	3	6	9	11	P024	-	F	General-purpose I/O port
						WR0X	-		External bus/Write strobe 0 output
						SIN4_1	-		Multi-function serial ch.4 serial data input (1)
						PPG24_0	-		PPG ch.24 output (0)
						TIN1_0	-		Reload timer ch.1 event input (0)
						RTO4_1	-		Waveform generator ch.4 output pin (1)
						INT15_0	-		INT15 External interrupt input (0)

MB91520 Series

Pin no.						Pin Name	Polarity	I/O circuit types*1	Function*2
64	80	100	120	144	176				
-	-	4	7	10	12	P025	-	A	General-purpose I/O port
						WR1X	-		External bus/Write strobe 1 output
						SOT4_1	-		Multi-function serial ch.4 serial data output (1)
						PPG25_0	-		PPG ch.25 output (0)
						TIN2_0	-		Reload timer ch.2 event input (0)
-	-	-	-	-	13	P172	-	A	General-purpose I/O port
						PPG38_1	-		PPG ch.38 output (1)
-	4	5	8	11	14	P026	-	F	General-purpose I/O port
						A00	-		External bus/Address bit0 output (0)
						SCK4_1	-		Multi-function serial ch.4 clock I/O (1)
						PPG26_0	-		PPG ch.26 output (0)
						TIN3_0	-		Reload timer ch.3 event input (0)
4	5	6	9	12	15	P027	-	A	General-purpose I/O port
						A01	-		External bus/Address bit1 output (0)
						SCS40_1	-		Serial chip select 40 I/O (1)
						PPG27_0	-		PPG ch.27 output (0)
						TOT0_0	-		Reload timer ch.0 output (0)
						RTO3_1	-		Waveform generator ch.3 output pin (1)
-	-	-	-	-	16	P173	-	A	General-purpose I/O port
						PPG39_1	-		PPG ch.39 output (1)
-	-	7	10	13	17	P030	-	A	General-purpose I/O port
						A02	-		External bus/Address bit2 output (0)
						SCS41_1	-		Serial chip select 41 output (1)
						PPG28_0	-		PPG ch.28 output (0)
						TOT1_0	-		Reload timer ch.1 output (0)
-	6	8	11	14	18	P031	-	A	General-purpose I/O port
						A03	-		External bus/Address bit3 output (0)
						SCS42_1	-		Serial chip select 42 output (1)
						PPG29_0	-		PPG ch.29 output (0)
						TOT2_0	-		Reload timer ch.2 output (0)
5	7	9	12	15	19	P032	-	A	General-purpose I/O port
						A04	-		External bus/Address bit4 output (0)
						SCS43_1	-		Serial chip select 43 output (1)
						PPG30_0	-		PPG ch.30 output (0)
						TOT3_0	-		Reload timer ch.3 output (0)
						RTO2_1	-		Waveform generator ch.2 output pin (1)
6	8	10	13	16	20	P033	-	A	General-purpose I/O port
						A05	-		External bus/Address bit5 output (0)
						PPG31_0	-		PPG ch.31 output (0)
						ICU3_3	-		Input capture ch.3 input (3)
						TIN4_0	-		Reload timer ch.4 event input (0)
						RTO1_1	-		Waveform generator ch.1 output pin (1)
						SCK3_2	-		Multi-function serial ch.3 clock I/O (2)

MB91520 Series

Pin no.						Pin Name	Polarity	I/O circuit types*1	Function*2
64	80	100	120	144	176				
7	9	11	14	17	21	P034	-	A	General-purpose I/O port
						A06	-		External bus/Address bit6 output (0)
						OCU11_1	-		Output compare ch.11 output (1)
						ICU2_3	-		Input capture ch.2 input (3)
						TIN5_0	-		Reload timer ch.5 event input (0)
						RTO0_1	-		Waveform generator ch.0 output pin (1)
						SOT3_2	-		Multi-function serial ch.3 serial data output (2)
-	-	12	15	18	22	P150	-	F	General-purpose I/O port
						SOT8_0/ SDA8	-		Multi-function serial ch.8 serial data output (0)/ I ² C bus serial data I/O
						OCU10_1	-		Output compare ch.10 output (1)
						TRG6_0	-		PPG trigger 6 input (0)
						ICU1_3	-		Input capture ch.1 input (3)
						TIN6_0	-		Reload timer ch.6 event input (0)
8	10	13	16	19	23	P151	-	F	General-purpose I/O port
						SCK8_0/ SCL8	-		Multi-function serial ch.8 clock I/O (0)/ I ² C bus serial clock I/O
						OCU9_1	-		Output compare ch.9 output (1)
						TRG7_0	-		PPG trigger 7 input (0)
						ICU0_3	-		Input capture ch.0 input (3)
						TIN7_0	-		Reload timer ch.7 event input (0)
						ZIN0_2	-		U/D counter ch.0 ZIN input (2)
						DTTI_1	-		Waveform generator ch.1 input pin (1)
9	11	14	17	20	24	P035	-	I	General-purpose I/O port
						A07	-		External bus/Address bit7 output
						SIN8_0	-		Multi-function serial ch.8 serial data input (0)
						OCU8_1	-		Output compare ch.8 output (1)
						TOT4_0	-		Reload timer ch.4 output (0)
						AIN0_0	-		U/D counter ch.0 AIN input (0)
						INT11_0	-		INT11 External interrupt input (0)
10	12	15	18	21	25	P036	-	A	General-purpose I/O port
						A08	-		External bus/Address bit8 output (0)
						SCS8_0	-		Serial chip select 8 I/O (0)
						OCU7_1	-		Output compare ch.7 output (1)
						TOT5_0	-		Reload timer ch.5 output (0)
						BIN0_0	-		U/D counter ch.0 BIN input (0)
-	-	16	19	22	26	P037	-	A	General-purpose I/O port
						A09	-		External bus/Address bit9 output (0)
						OCU6_1	-		Output compare ch.6 output (1)
						TOT6_0	-		Reload timer ch.6 output (0)
						ZIN0_0	-		U/D counter ch.0 ZIN input (0)
-	-	-	-	-	27	P174	-	A	General-purpose I/O port
						TRG8_1	-		PPG trigger 8 input (1)
-	-	-	-	-	28	P175	-	A	General-purpose I/O port
						TRG9_1	-		PPG trigger 9 input (1)

MB91520 Series

Pin no.						Pin Name	Polarity	I/O circuit types*1	Function*2
64	80	100	120	144	176				
11	13	17	20	23	29	P040	-	A	General-purpose I/O port
						A10	-		External bus/Address bit10 output (0)
						PPG23_1	-		PPG ch.23 output (1)
						TOT7_0	-		Reload timer ch.7 output (0)
						AIN1_0	-		U/D counter ch.1 AIN input (0)
						SIN0_1	-		Multi-function serial ch.0 serial data input (1)
12	14	18	21	24	30	P041	-	I	General-purpose I/O port
						A11	-		External bus/Address bit11 output (0)
						SIN9_0	-		Multi-function serial ch.9 serial data input (0)
						ICU9_1	-		Input capture ch.9 input (1)
						BIN1_0	-		U/D counter ch.1 BIN input (0)
						INT12_0	-		INT12 External interrupt input (0)
13	15	19	22	25	31	P042	-	B	General-purpose I/O port
						A12	-		External bus/Address bit12 output
						SOT9_0	-		Multi-function serial ch.9 serial data output (0)
						AN47	-		ADC analog 47 input
						ICU8_1	-		Input capture ch.8 input (1)
						TRG0_1	-		PPG trigger 0 input (1)
						ZIN1_0	-		U/D counter ch.1 ZIN input (0)
-	-	20	23	26	32	P043	-	A	General-purpose I/O port
						A13	-		External bus/Address bit13 output (0)
						ICU7_1	-		Input capture ch.7 input (1)
						TRG1_1	-		PPG trigger 1 input (1)
-	16	21	24	27	33	P044	-	A	General-purpose I/O port
						A14	-		External bus/Address bit14 output (0)
						SCS9_0	-		Serial chip select 9 I/O (0)
						ICU6_1	-		Input capture ch.6 input (1)
						TRG2_1	-		PPG trigger 2 input (1)
14	17	22	25	28	34	P045	-	G	General-purpose I/O port
						A15	-		External bus/Address bit15 output (0)
						SCK9_0	-		Multi-function serial ch.9 clock I/O (0)
						AN46	-		ADC analog 46 input
						ICU5_1	-		Input capture ch.5 input (1)
						TRG3_1	-		PPG trigger 3 input (1)
						TOT1_2	-		Reload timer ch.1 output (2)
-	-	-	26	29	35	P046	-	A	General-purpose I/O port
						A16	-		External bus/Address bit16 output (0)
						ICU4_1	-		Input capture ch.4 input (1)
						TRG4_1	-		PPG trigger 4 input (1)
-	-	-	-	-	36	P176	-	A	General-purpose I/O port
						TRG10_0	-		PPG trigger 10 input (0)

MB91520 Series

Pin no.						Pin Name	Polarity	I/O circuit types*1	Function*2
64	80	100	120	144	176				
15	18	23	27	30	37	P047	-	B	General-purpose I/O port
						A17	-		External bus/Address bit17 output (0)
						AN45	-		ADC analog 45 input
						TRG8_0	-		PPG trigger 8 input (0)
						TIN3_2	-		Reload timer ch.3 event input (2)
						SOT0_1	-		Multi-function serial ch.0 serial data output (1)
-	-	-	-	-	38	P177	-	A	General-purpose I/O port
						TRG11_0	-		PPG trigger 11 input (0)
-	-	-	28	31	39	P050	-	A	General-purpose I/O port
						A18	-		External bus/Address bit18 output
						TRG5_1	-		PPG trigger 5 input (1)
						PPG33_0	-		PPG ch.33 output (0)
-	-	-	-	32	40	P051	-	A	General-purpose I/O port
						A19	-		External bus/Address bit19 output
						TRG9_0	-		PPG trigger 9 input (0)
-	-	-	-	33	41	P052	-	A	General-purpose I/O port
						A20	-		External bus/Address bit20 output
						PPG34_0	-		PPG ch.34 output (0)
						INT14_0	-		INT14 External interrupt input (0)
16	19	24	29	34	42	P053	-	B	General-purpose I/O port
						A21	-		External bus/Address bit21 output
						AN44	-		ADC analog 44 input
						PPG35_0	-		PPG ch.35 output (0)
						INT14_1	-		INT14 External interrupt input (1)
						SCK0_1	-		Multi-function serial ch.0 clock I/O (1)
-	-	-	-	35	43	P054	-	A	General-purpose I/O port
						SYSCLK	-		External bus/System clock output
						PPG36_0	-		PPG ch.36 output (0)
17	22	27	32	38	46	P055	-	G	General-purpose I/O port
						CS2X	-		External bus chip select 2 output (0)
						SIN10_0	-		Multi-function serial ch.10 serial data input (0)
						AN43	-		ADC analog 43 input
						PPG37_0	-		PPG ch.37 output (0)
						TIN4_1	-		Reload timer ch.4 event input (1)
-	-	-	-	-	47	P180	-	A	General-purpose I/O port
						PPG40_0	-		PPG ch.40 output (0)
-	-	-	-	-	48	P181	-	A	General-purpose I/O port
						PPG41_0	-		PPG ch.41 output (0)
-	-	-	33	39	49	P056	-	A	General-purpose I/O port
						CS3X	-		External bus chip select 3 output (0)
						ICU9_0	-		Input capture ch.9 input (0)
						PPG0_1	-		PPG ch.0 output (1)
						ICU0_1	-		Input capture ch.0 input (1)
						TIN5_1	-		Reload timer ch.5 event input (1)
						DTTI_2	-		Waveform generator ch.0-ch.5 input pin (2)

MB91520 Series

Pin no.						Pin Name	Polarity	I/O circuit types*1	Function*2
64	80	100	120	144	176				
19	24	29	35	41	51	P057	-	G	General-purpose I/O port
						RDY	-		External bus/Ready input (0)
						SCK10_1	-		Multi-function serial ch.10 clock I/O (1)
						AN42	-		ADC analog 42 input
						ICU8_0	-		Input capture ch.8 input (0)
						TRG0_2	-		PPG trigger 0 input (2)
						PPG1_1	-		PPG ch.1 output (1)
						ICU1_1	-		Input capture ch.1 input (1)
						TIN6_1	-		Reload timer ch.6 event input (1)
-	-	-	-	44	54	P142	-	F	General-purpose I/O port
						SCK10_0/ SCL10	-		Multi-function serial ch.10 clock I/O (0)/ I ² C bus serial clock I/O
						PPG38_0	-		PPG ch.38 output (0)
						TIN7_1	-		Reload timer ch.7 event input (1)
-	-	-	-	45	55	P143	-	F	General-purpose I/O port
						SOT10_0/ SDA10	-		Multi-function serial ch.10 serial data output (0)/ I ² C bus serial data I/O
						PPG39_0	-		PPG ch.39 output (0)
						TOT4_1	-		Reload timer ch.4 output (1)
-	-	-	-	-	56	P182	-	A	General-purpose I/O port
						PPG42_0	-		PPG ch.42 output (0)
-	-	32	38	46	57	P060	-	A	General-purpose I/O port
						SCS10_0	-		Serial chip select 10 I/O (0)
						PPG2_1	-		PPG ch.2 output (1)
						ICU2_1	-		Input capture ch.2 input (1)
						TOT5_1	-		Reload timer ch.5 output (1)
						INT13_0	-		INT13 External interrupt input (0)
22	27	33	39	47	58	P061	-	B	General-purpose I/O port
						SOT10_1	-		Multi-function serial ch.10 serial data output (1)
						AN41	-		ADC analog 41 input
						ICU6_0	-		Input capture ch.6 input (0)
						PPG3_1	-		PPG ch.3 output (1)
						ICU3_1	-		Input capture ch.3 input (1)
						TOT6_1	-		Reload timer ch.6 output (1)
						INT13_1	-		INT13 External interrupt input (1)
23	28	34	40	48	59	P062	-	B	General-purpose I/O port
						SCS10_1	-		Serial chip select 10 I/O (1)
						SCS40_0	-		Serial chip select 40 I/O (0)
						AN40	-		ADC analog 40 input
						PPG4_1	-		PPG ch.4 output (1)
						FRCK0_0	-		Free-run timer 0 clock input (0)
						TOT7_1	-		Reload timer ch.7 output (1)
						ZIN1_1	-		U/D counter ch.1 ZIN input (1)

MB91520 Series

Pin no.						Pin Name	Polarity	I/O circuit types*1	Function*2
64	80	100	120	144	176				
-	29	35	41	49	60	P063	-	B	General-purpose I/O port
						SCS41_0	-		Serial chip select 41 output (0)
						AN39	-		ADC analog 39 input
						PPG5_1	-		PPG ch.5 output (1)
						FRCK1_0	-		Free-run timer 1 clock input (0)
						BIN1_1	-		U/D counter ch.1 BIN input (1)
-	-	-	-	-	61	P183	-	A	General-purpose I/O port
						PPG43_0	-		PPG ch.43 output (0)
24	30	36	42	50	62	P064	-	B	General-purpose I/O port
						SCS42_0	-		Serial chip select 42 output (0)
						AN38	-		ADC analog 38 input
						FRCK2_0	-		Free-run timer 2 clock input (0)
						AIN1_1	-		U/D counter ch.1 AIN input (1)
						PPG43_1	-		PPG ch.43 output (1)
-	-	37	43	51	63	P065	-	A	General-purpose I/O port
						SCS43_0	-		Serial chip select 43 output (0)
						FRCK3_0	-		Free-run timer 3 clock input (0)
						ZIN0_1	-		U/D counter ch.0 ZIN input (1)
						PPG44_1	-		PPG ch.44 output (1)
-	-	-	-	-	64	P184	-	A	General-purpose I/O port
						PPG44_0	-		PPG ch.44 output (0)
-	-	-	-	-	65	P185	-	A	General-purpose I/O port
						PPG45_0	-		PPG ch.45 output (0)
25	31	38	44	52	66	P066	-	B	General-purpose I/O port
						SOT4_2	-		Multi-function serial ch.4 serial data output (2)
						SCS3_0	-		Serial chip select 3 I/O (0)
						AN37	-		ADC analog 37 input
						FRCK4_0	-		Free-run timer 4 clock input (0)
						BIN0_1	-		U/D counter ch.0 BIN input (1)
-	32	39	45	53	67	P067	-	B	General-purpose I/O port
						AN36	-		ADC analog 36 input
						FRCK5_0	-		Free-run timer 5 clock input (0)
						AIN0_1	-		U/D counter ch.0 AIN input (1)
-	-	40	46	54	68	P070	-	A	General-purpose I/O port
						ICU0_2	-		Input capture ch.0 input (2)
26	33	41	47	55	69	P071	-	G	General-purpose I/O port
						SCK4_2	-		Multi-function serial ch.4 clock I/O (2)
						AN35	-		ADC analog 35 input
						ICU1_2	-		Input capture ch.1 input (2)
						MONCLK	-		Clock monitor output pin

MB91520 Series

Pin no.						Pin Name	Polarity	I/O circuit types*1	Function*2
64	80	100	120	144	176				
27	34	42	48	56	70	P072	-	G	General-purpose I/O port
						SIN4_0	-		Multi-function serial ch.4 serial data input (0)
						AN34	-		ADC analog 34 input
						ICU2_2	-		Input capture ch.2 input (2)
						INT5_0	-		INT5 External interrupt input (0)
-	35	43	49	57	71	P073	-	D	General-purpose I/O port
						SOT4_0/ SDA4	-		Multi-function serial ch.4 serial data output (0)/I ² C bus serial data I/O
						AN33	-		ADC analog 33 input
						ICU3_2	-		Input capture ch.3 input (2)
-	-	-	-	-	72	P186	-	A	General-purpose I/O port
						PPG46_0	-		PPG ch.46 output (0)
-	-	-	-	-	73	P187	-	A	General-purpose I/O port
						PPG47_0	-		PPG ch.47 output (0)
-	-	-	50	58	74	P074	-	E	General-purpose I/O port
						SCK4_0/ SCL4	-		Multi-function serial ch.4 clock I/O (0)/ I ² C bus serial clock I/O
-	-	-	51	59	75	P075	-	F	General-purpose I/O port
						SIN3_0	-		Multi-function serial ch.3 serial data input (0)
						INT4_0	-		INT4 External interrupt input (0)
-	-	-	52	60	76	P076	-	E	General-purpose I/O port
						SOT3_0/ SDA3	-		Multi-function serial ch.3 serial data output (0)/I ² C bus serial data I/O
-	-	-	53	61	77	P077	-	E	General-purpose I/O port
						SCK3_0/ SCL3	-		Multi-function serial ch.3 clock I/O (0)/ I ² C bus serial clock I/O
-	-	44	54	62	78	P152	-	A	General-purpose I/O port
						SCS53_0	-		Serial chip select 53 output (0)
28	36	45	55	63	79	P153	-	G	General-purpose I/O port
						SCK5_0/ SCL5	-		Multi-function serial ch.5 clock I/O (0)/ I ² C bus serial clock I/O
						AN32	-		ADC analog 32 input
						FRCK1_1	-		Free-run timer 1 clock input (1)
						INT4_1	-		INT4 External interrupt input (1)
-	-	-	-	64	80	P080	-	A	General-purpose I/O port
						SCS52_0	-		Serial chip select 52 output (0)
						PPG0_0	-		PPG ch.0 output (0)
29	37	46	56	65	81	P081	-	G	General-purpose I/O port
						SOT5_0/ SDA5	-		Multi-function serial ch.5 serial data output (0)/I ² C bus serial data I/O
						AN0	-		ADC analog 0 input
						PPG1_0	-		PPG ch.1 output (0)
30	38	47	57	66	82	P082	-	G	General-purpose I/O port
						SIN5_0	-		Multi-function serial ch.5 serial data input (0)
						AN1	-		ADC analog 1 input
						PPG2_0	-		PPG ch.2 output (0)

MB91520 Series

Pin no.						Pin Name	Polarity	I/O circuit types*1	Function*2
64	80	100	120	144	176				
-	-	-	-	67	83	P083	-	B	General-purpose I/O port
						SCS50_0	-		Serial chip select 50 I/O (0)
						AN2	-		ADC analog 2 input
						PPG3_0	-		PPG ch.3 output (0)
-	-	-	-	68	84	P084	-	B	General-purpose I/O port
						SCS51_0	-		Serial chip select 51 output (0)
						AN3	-		ADC analog 3 input
						PPG4_0	-		PPG ch.4 output (0)
-	-	-	-	69	85	P085	-	A	General-purpose I/O port
						PPG5_0	-		PPG ch.5 output (0)
-	-	48	58	70	86	P086	-	C	General-purpose I/O port
						DAO1	-		DAC analog 1 output
						PPG6_0	-		PPG ch.6 output (0)
31	39	49	59	71	87	P087	-	C	General-purpose I/O port
						DAO0	-		DAC analog 0 output
						PPG7_0	-		PPG ch.7 output (0)
						INT8_0	-		INT8 External interrupt input (0)
-	-	-	-	-	90	P190	-	A	General-purpose I/O port
						TIN0_1	-		Reload timer ch.0 event input (1)
-	-	-	-	-	91	P191	-	A	General-purpose I/O port
						TIN1_1	-		Reload timer ch.1 event input (1)
-	-	-	-	74	92	P090	-	B	General-purpose I/O port
						AN4	-		ADC analog 4 input
						ICU0_0	-		Input capture ch.0 input (0)
						TIN2_1	-		Reload timer ch.2 event input (1)
-	-	-	-	75	93	P091	-	B	General-purpose I/O port
						AN5	-		ADC analog 5 input
						PPG41_1	-		PPG ch.41 output (1)
						ICU1_0	-		Input capture ch.1 input (0)
						TIN3_1	-		Reload timer ch.3 event input (1)
-	-	-	-	76	94	P092	-	B	General-purpose I/O port
						AN6	-		ADC analog 6 input
						PPG40_1	-		PPG ch.40 output (1)
						ICU2_0	-		Input capture ch.2 input (0)
						TOT0_1	-		Reload timer ch.0 output (1)
-	-	-	-	-	95	P192	-	A	General-purpose I/O port
						PPG24_1	-		PPG ch.24 output (1)
						TOT1_1	-		Reload timer ch.1 output (1)
34	42	52	62	77	96	P093	-	J	General-purpose I/O port
						TX0_1	-		CAN transmission data 0 output (1)
						SIN11_0	-		Multi-function serial ch.11 serial data input (0)
						AN7	-		ADC analog 7 input
						ICU4_2	-		Input capture ch.4 input (2)
						PPG16_1	-		PPG ch.16 output (1)
						ICU3_0	-		Input capture ch.3 input (0)
						TOT2_1	-		Reload timer ch.2 output (1)

MB91520 Series

Pin no.						Pin Name	Polarity	I/O circuit types*1	Function*2
64	80	100	120	144	176				
-	-	-	-	78	97	P094	-	B	General-purpose I/O port
						AN8	-		ADC analog 8 input
						ICU4_0	-		Input capture ch.4 input (0)
						TOT3_1	-		Reload timer ch.3 output (1)
-	-	53	63	79	98	P095	-	B	General-purpose I/O port
						TX0(128)	-		CAN transmission data 0 output
						SCS11_0	-		Serial chip select 11 I/O (0)
						AN9	-		ADC analog 9 input
35	43	54	64	80	99	P096	-	G	General-purpose I/O port
						RX0(128)	-		CAN reception data 0 input
						SOT11_0/ SDA11	-		Multi-function serial ch.11 serial data output (0)/I ² C bus serial data I/O
						AN10	-		ADC analog 10 input
						INT0_0	-		INT0 External interrupt input (0)
36	44	55	65	81	100	P097	-	G	General-purpose I/O port
						SCK11_0/ SCL11	-		Multi-function serial ch.11 clock I/O (0)/I ² C bus serial clock I/O
						AN11	-		ADC analog 11 input
						ICU5_0	-		Input capture ch.5 input (0)
						PPG17_1	-		PPG ch.17 output (1)
-	48	59	69	85	104	P100	-	G	General-purpose I/O port
						SCK7_0/ SCL7	-		Multi-function serial ch.7 clock I/O (0)/I ² C bus serial clock I/O
						AN12	-		ADC analog 12 input
						PPG8_0	-		PPG ch.8 output (0)
-	-	60	70	86	105	P101	-	G	General-purpose I/O port
						SOT7_0/ SDA7	-		Multi-function serial ch.7 serial data output (0)/I ² C bus serial data I/O
						AN13	-		ADC analog 13 input
						PPG9_0	-		PPG ch.9 output (0)
40	49	61	71	87	106	P102	-	G	General-purpose I/O port
						SIN7_0	-		Multi-function serial ch.7 serial data input (0)
						AN14	-		ADC analog 14 input
						PPG10_0	-		PPG ch.10 output (0)
						INT10_0	-		INT10 External interrupt input (0)
41	50	62	72	88	107	P103	-	H	General-purpose I/O port
						SCS73_0	-		Serial chip select 73 output (0)
						AN15	-		ADC analog 15 input
						PPG11_0	-		PPG ch.11 output (0)
42	51	63	73	89	108	P104	-	H	General-purpose I/O port
						SCS72_0	-		Serial chip select 72 output (0)
						AN16	-		ADC analog 16 input
						PPG12_0	-		PPG ch.12 output (0)
43	52	64	74	90	109	P105	-	H	General-purpose I/O port
						SCS71_0	-		Serial chip select 71 output (0)
						AN17	-		ADC analog 17 input
						PPG13_0	-		PPG ch.13 output (0)

MB91520 Series

Pin no.						Pin Name	Polarity	I/O circuit types*1	Function*2
64	80	100	120	144	176				
-	-	65	75	91	110	P106	-	H	General-purpose I/O port
						SCS70_0	-		Serial chip select 70 I/O (0)
						AN18	-		ADC analog 18 input
						PPG14_0	-		PPG ch.14 output (0)
-	53	66	76	92	111	P107	-	B	General-purpose I/O port
						AN19	-		ADC analog 19 input
						PPG15_0	-		PPG ch.15 output (0)
-	-	-	-	-	112	P193	-	A	General-purpose I/O port
						PPG25_1	-		PPG ch.25 output (1)
-	-	-	77	93	113	P154	-	B	General-purpose I/O port
						AN20	-		ADC analog 20 input
-	-	-	78	94	114	P155	-	B	General-purpose I/O port
						AN21	-		ADC analog 21 input
44	54	67	79	95	115	NMIX	N	M	Non-masking interrupt input
45	55	68	80	96	116	P110	-	B	General-purpose I/O port
						TX1(64)	-		CAN transmission data 1 output
						SCS63_0	-		Serial chip select 63 output (0)
						AN22	-		ADC analog 22 input
-	-	69	81	97	117	P111	-	G	General-purpose I/O port
						RX1(64)	-		CAN reception data 1 input
						SCS62_0	-		Serial chip select 62 output (0)
						AN23	-		ADC analog 23 input
						INT1_0	-		INT1 External interrupt input (0)
-	-	-	82	98	118	P112	-	B	General-purpose I/O port
						AN24	-		ADC analog 24 input
						PPG16_0	-		PPG ch.16 output (0)
						RTO0_0	-		Waveform generator ch. 0 output pin (0)
-	-	-	83	99	119	P113	-	B	General-purpose I/O port
						AN25	-		ADC analog 25 input
						PPG17_0	-		PPG ch.17 output (0)
						RTO1_0	-		Waveform generator ch. 1 output pin (0)
-	-	-	-	-	120	P194	-	A	General-purpose I/O port
						FRCK5_1	-		Free-run timer 5 clock input (1)
						PPG26_1	-		PPG ch.26 output (1)
-	-	-	-	-	121	P195	-	A	General-purpose I/O port
						FRCK4_1	-		Free-run timer 4 clock input (1)
						PPG27_1	-		PPG ch.27 output (1)
-	56	70	84	100	122	P114	-	B	General-purpose I/O port
						SCS61_0	-		Serial chip select 61 output (0)
						AN26	-		ADC analog 26 input
						PPG18_0	-		PPG ch.18 output (0)
						RTO2_0	-		Waveform generator ch.2 output pin (0)

MB91520 Series

Pin no.						Pin Name	Polarity	I/O circuit types*1	Function*2
64	80	100	120	144	176				
46	57	71	85	101	123	P115	-	G	General-purpose I/O port
						RX1_1	-		CAN reception data 1 input (1)
						SOT6_0/ SDA6	-		Multi-function serial ch.6 serial data output (0)/I ² C bus serial data I/O
						AN27	-		ADC analog 27 input
						PPG19_0	-		PPG ch.19 output (0)
						RTO3_0	-		Waveform generator ch.3 output pin (0)
						INT1_1	-		INT1 External interrupt input (1)
47	58	72	86	102	124	P116	-	G	General-purpose I/O port
						SCK6_0/ SCL6	-		Multi-function serial ch.6 clock I/O (0)/I ² C bus serial clock I/O
						AN28	-		ADC analog 28 input
						PPG20_0	-		PPG ch.20 output (0)
						RTO4_0	-		Waveform generator ch.4 output pin (0)
-	-	73	87	103	125	P117	-	B	General-purpose I/O port
						SCS60_0	-		Serial chip select 60 I/O (0)
						AN29	-		ADC analog 29 input
						PPG21_0	-		PPG ch.21 output (0)
						RTO5_0	-		Waveform generator ch.5 output pin (0)
-	-	-	-	-	126	P196	-	A	General-purpose I/O port
						FRCK3_1	-		Free-run timer 3 clock input (1)
						PPG28_1	-		PPG ch.28 output (1)
-	-	-	88	104	127	P120	-	B	General-purpose I/O port
						AN30	-		ADC analog 30 input
						OCU6_0	-		Output compare ch.6 output (0)
						PPG22_0	-		PPG ch.22 output (0)
						INT9_0	-		INT9 External interrupt input (0)
-	-	-	-	105	128	P121	-	A	General-purpose I/O port
						OCU7_0	-		Output compare ch.7 output (0)
						PPG23_0	-		PPG ch.23 output (0)
48	59	74	89	106	129	P122	-	J	General-purpose I/O port
						SIN6_0	-		Multi-function serial ch.6 serial data input (0)
						AN31	-		ADC analog 31 input
						OCU8_0	-		Output compare ch.8 output (0)
						INT9_1	-		INT9 External interrupt input (1)
-	-	-	-	-	130	P197	-	A	General-purpose I/O port
						PPG29_1	-		PPG ch.29 output (1)
-	-	-	-	107	131	P123	-	A	General-purpose I/O port
						OCU9_0	-		Output compare ch.9 output (0)
49	62	77	92	110	134	DEBUGIF	-	L	MDI I/O for debugger (OCD)
-	-	-	-	-	135	P160	-	A	General-purpose I/O port
						PPG30_1	-		PPG ch.30 output (1)
-	-	-	-	-	136	P161	-	A	General-purpose I/O port
						PPG31_1	-		PPG ch.31 output (1)
-	-	-	-	111	137	P124	-	A	General-purpose I/O port
						OCU10_0	-		Output compare ch.10 output (0)

MB91520 Series

Pin no.						Pin Name	Polarity	I/O circuit types*1	Function*2
64	80	100	120	144	176				
-	-	-	93	112	138	P125	-	A	General-purpose I/O port
						OCU11_0	-		Output compare ch.11 output (0)
50	63	78	94	113	139	P126	-	F	General-purpose I/O port
						SIN0_0	-		Multi-function serial ch.0 serial data input (0)
						INT6_0	-		INT6 External interrupt input (0)
-	64	79	95	114	140	P127	-	A	General-purpose I/O port
						SOT0_0	-		Multi-function serial ch.0 serial data output (0)
-	-	80	96	115	141	P130	-	F	General-purpose I/O port
						SCK0_0	-		Multi-function serial ch.0 clock I/O (0)
-	-	-	-	-	142	P162	-	A	General-purpose I/O port
						TRG5_2	-		PPG trigger 5 input (2)
-	-	-	-	-	143	P163	-	A	General-purpose I/O port
						TRG6_2	-		PPG trigger 6 input (2)
51	65	81	97	116	144	MD0	-	K	Mode pin 0
52	66	82	98	117	145	MD1	-	K	Mode pin 1
53	67	83	99	118	146	X0	-	N	Main clock oscillation input
54	68	84	100	119	147	X1	-	N	Main clock oscillation output
56	70	86	102	121	149	P135	-	A	General-purpose I/O port
						DTTI_0	-		Waveform generator ch.0-ch.5 input pin (0)
						X1A	-	O	Sub clock oscillation output
57	71	87	103	122	150	P136	-	A	General-purpose I/O port
						X0A	-	O	Sub clock oscillation input
58	72	88	104	123	151	RSTX	N	M	External reset input
-	-	-	-	124	152	P131	-	A	General-purpose I/O port
						ADTG0_0	-		A/D converter external trigger input 0 (0)
-	-	-	105	125	153	P132	-	A	General-purpose I/O port
						SCS1_0	-		Serial chip select 1 I/O (0)
						ADTG1_0	-		A/D converter external trigger input 1 (0)
-	-	89	106	126	154	P133	-	A	General-purpose I/O port
						TX2(64)	-		CAN transmission data 2 output
-	-	90	107	127	155	P134	-	F	General-purpose I/O port
						RX2(64)	-		CAN reception data 2 input
						SCS1_1	-		Serial chip select 1 I/O (1)
						ICU7_0	-		Input capture ch.7 input (0)
						INT7_0	-		INT7 External interrupt input (0)
-	-	91	108	128	156	P144	-	F	General-purpose I/O port
						SCK1_1	-		Multi-function serial ch.1 clock I/O (1)
-	-	94	111	131	159	P000	-	F	General-purpose I/O port
						D16	-		External bus data bit16 I/O (0)
						SIN1_0	-		Multi-function serial ch.1 serial data input (0)
						TIOA0_1	-		TIOA output of Base timer ch.0 (1)
						INT2_0	-		INT2 External interrupt input (0)
-	75	95	112	132	160	P001	-	A	General-purpose I/O port
						D17	-		External bus data bit17 I/O
						SOT1_0	-		Multi-function serial ch.1 serial data output (0)
						TIOA1_1	-		TIOA I/O of Base timer ch.1 (1)

MB91520 Series

Pin no.						Pin Name	Polarity	I/O circuit types*1	Function*2
64	80	100	120	144	176				
-	-	-	113	133	161	P002	-	F	General-purpose I/O port
						D18	-		External bus data bit18 I/O
						SCK1_0	-		Multi-function serial ch.1 clock I/O (0)
						TIOB0_1	-		TIOB input of Base timer ch.0 (1)
-	76	96	114	134	162	P003	-	F	General-purpose I/O port
						D19	-		External bus data bit19 I/O
						SIN2_0	-		Multi-function serial ch.2 serial data input (0)
						TIOB1_1	-		TIOB input of Base timer ch.1 (1)
						INT3_0	-		INT3 External interrupt input (0)
-	-	-	-	135	163	P004	-	A	General-purpose I/O port
						D20	-		External bus data bit20 I/O (0)
						SOT2_0	-		Multi-function serial ch.2 serial data output (0)
-	-	-	-	-	164	P164	-	A	General-purpose I/O port
						PPG32_1	-		PPG ch.32 output (1)
61	77	97	115	136	165	P005	-	F	General-purpose I/O port
						D21	-		External bus data bit21 I/O (0)
						SCK2_0	-		Multi-function serial ch.2 clock I/O (0)
						ADTG0_1	-		A/D converter external trigger input 0 (1)
						INT7_1	-		INT7 External interrupt input (1)
						(RX2(64))	-		(CAN reception data 2 input MB91F52xB ,MB91F52xD only)
-	-	-	-	-	166	P165	-	A	General-purpose I/O port
						PPG33_1	-		PPG ch.33 output (1)
62	78	98	116	137	167	P006	-	A	General-purpose I/O port
						D22	-		External bus data bit22 I/O (0)
						SCS2_0	-		Serial chip select 2 I/O (0)
						ADTG1_1	-		A/D converter external trigger input 1 (1)
						INT2_1	-		INT2 External interrupt input (1)
						(TX2(64))	-		(CAN transmission data 2 output MB91F52xB ,MB91F52xD only)
-	-	-	117	138	168	P007	-	A	General-purpose I/O port
						D23	-		External bus data bit23 I/O
-	-	-	-	-	169	P166	-	A	General-purpose I/O port
						PPG34_1	-		PPG ch.34 output (1)
-	-	-	118	139	170	P010	-	A	General-purpose I/O port
						D24	-		External bus data bit24 I/O
63	79	99	119	140	171	P011	-	A	General-purpose I/O port
						WOT	-		RTC output signal
						D25	-		External bus data bit25 I/O
						SOT2_1	-		Multi-function serial ch.2 serial data output (1)
						TIOA0_0	-		TIOA output of Base timer ch.0 (0)
						INT3_1	-		INT3 External interrupt input (1)
-	-	-	-	141	172	P012	-	A	General-purpose I/O port
						D26	-		External bus data bit26 I/O
						TIOB0_0	-		TIOB input of Base timer ch.0 (0)
-	-	-	-	-	173	P167	-	A	General-purpose I/O port
						PPG35_1	-		PPG ch.35 output (1)

MB91520 Series

Pin no.						Pin Name	Polarity	I/O circuit types*1	Function*2
64	80	100	120	144	176				
-	-	-	-	142	174	P013	-	A	General-purpose I/O port
-	-	-	-	-	-	D27	-		External bus data bit27 I/O
-	-	-	-	-	-	TIOA1_0	-		TIOA I/O of Base timer ch.1 (0)
-	-	-	-	143	175	P014	-	A	General-purpose I/O port
-	-	-	-	-	-	D28	-		External bus data bit28 I/O
-	-	-	-	-	-	TIOB1_0	-		TIOB input of Base timer ch.1 (0)
18	23	28	34	40	50	AVCC1	-	-	Analog power supply for AD/DA convertor unit1
39	47	58	68	84	103	AVCC0	-	-	Analog power supply for AD/DA convertor unit0
20	25	30	36	42	52	AVRH1	-	-	Upper limit reference voltage for AD convertor unit1
38	46	57	67	83	102	AVRH0	-	-	Upper limit reference voltage for AD convertor unit0
21	26	31	37	43	53	AVSS1/ AVRL1	-	-	GND for AD/DA convertor unit1 Lower limit reference voltage for AD convertor unit1
37	45	56	66	82	101	AVSS0/ AVRL0	-	-	GND for AD/DA convertor unit0 Lower limit reference voltage for AD convertor unit0
60	74	93	110	130	158	C	-	-	External capacity connection output
-	20	25	30	36	44	VCC	-	-	+5.0V power supply
32	40	50	60	72	88				
-	61	76	91	109	133				
64	80	100	120	144	176				
1	1	1	1	1	1	VSS	-	-	GND
-	21	26	31	37	45				
33	41	51	61	73	89				
-	60	75	90	108	132				
55	69	85	101	120	148				
59	73	92	109	129	157				

*1: For the I/O circuit types, see "■I/O CIRCUIT TYPE".

*2: For switching, see "I/O Port" in HARDWARE MANUAL.

■ I/O CIRCUIT TYPE

Type	Circuit	Remarks
A		<ul style="list-style-type: none"> • General-purpose I/O port • Output 4mA • Pull-up resistor control 50kΩ • Automotive input
B		<ul style="list-style-type: none"> • Analog input, General-purpose I/O port • Output 4mA • Pull-up resistor control 50kΩ • Automotive input
C		<ul style="list-style-type: none"> • DAC output, General-purpose I/O port • Output 4mA • Pull-up resistor control 50kΩ • Automotive input
D		<ul style="list-style-type: none"> • I²C Analog input, General-purpose I/O port • Output 3mA • Pull-up resistor control 50kΩ • I²C schmitt input

MB91520 Series

Type	Circuit	Remarks
E		<ul style="list-style-type: none"> • I²C, General-purpose I/O port • Output 3mA • Pull-up resistor control 50kΩ • I²C schmitt input
F		<ul style="list-style-type: none"> • General-purpose I/O port • Output 4mA • Pull-up resistor control 50kΩ • Schmitt input
G		<ul style="list-style-type: none"> • Analog input, General-purpose I/O port • Output 4mA • Pull-up resistor control 50kΩ • Schmitt input
H		<ul style="list-style-type: none"> • Analog input, General-purpose I/O port • Output 12mA • Pull-up resistor control 50kΩ • Automotive input

Type	Circuit	Remarks
I		<ul style="list-style-type: none"> • 3V pad power supply (5V tolerant), General-purpose I/O port • Output 4mA • Schmitt input
J		<ul style="list-style-type: none"> • 3V pad power supply (5V tolerant), Analog input, General-purpose I/O port • Output 4mA • Schmitt input
K		<ul style="list-style-type: none"> • Mode I/O • Schmitt input
L		<ul style="list-style-type: none"> • Open-drain I/O • Output 25mA (NOD) • TTL input

MB91520 Series

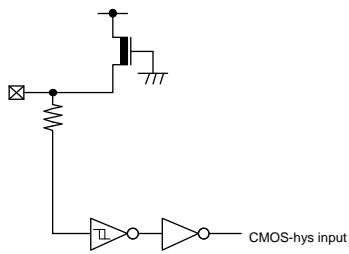
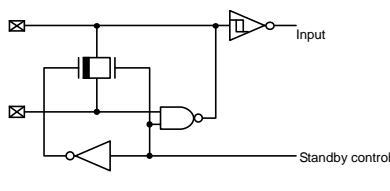
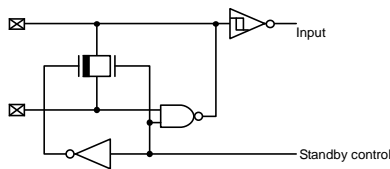
Type	Circuit	Remarks
M		<ul style="list-style-type: none"> • Schmitt input • Pull-up resistor 50kΩ (5V cont)
N		<ul style="list-style-type: none"> • Main oscillation I/O
O		<ul style="list-style-type: none"> • Sub oscillation I/O

■ HANDLING PRECAUTIONS

Any semiconductor devices have inherently a certain rate of failure. The possibility of failure is greatly affected by the conditions in which they are used (circuit conditions, environmental conditions, etc.). This page describes precautions that must be observed to minimize the chance of failure and to obtain higher reliability from your FUJITSU SEMICONDUCTOR semiconductor devices.

1. Precautions for Product Design

This section describes precautions when designing electronic equipment using semiconductor devices.

• Absolute Maximum Ratings

Semiconductor devices can be permanently damaged by application of stress (voltage, current, temperature, etc.) in excess of certain established limits, called absolute maximum ratings. Do not exceed these ratings.

• Recommended Operating Conditions

Recommended operating conditions are normal operating ranges for the semiconductor device. All the device's electrical characteristics are warranted when operated within these ranges.

Always use semiconductor devices within the recommended operating conditions. Operation outside these ranges may adversely affect reliability and could result in device failure.

No warranty is made with respect to uses, operating conditions, or combinations not represented on the data sheet. Users considering application outside the listed conditions are advised to contact their sales representative beforehand.

• Processing and Protection of Pins

These precautions must be followed when handling the pins which connect semiconductor devices to power supply and input/output functions.

(1) Preventing Over-Voltage and Over-Current Conditions

Exposure to voltage or current levels in excess of maximum ratings at any pin is likely to cause deterioration within the device, and in extreme cases leads to permanent damage of the device. Try to prevent such overvoltage or over-current conditions at the design stage.

(2) Protection of Output Pins

Shorting of output pins to supply pins or other output pins, or connection to large capacitance can cause large current flows. Such conditions if present for extended periods of time can damage the device.

Therefore, avoid this type of connection.

(3) Handling of Unused Input Pins

Unconnected input pins with very high impedance levels can adversely affect stability of operation. Such pins should be connected through an appropriate resistance to a power supply pin or ground pin.

• Latch-up

Semiconductor devices are constructed by the formation of P-type and N-type areas on a substrate. When subjected to abnormally high voltages, internal parasitic PNP junctions (called thyristor structures) may be formed, causing large current levels in excess of several hundred mA to flow continuously at the power supply pin. This condition is called latch-up.

CAUTION: The occurrence of latch-up not only causes loss of reliability in the semiconductor device, but can cause injury or damage from high heat, smoke or flame. To prevent this from happening, do the following:

(1) Be sure that voltages applied to pins do not exceed the absolute maximum ratings. This should include attention to abnormal noise, surge levels, etc.

(2) Be sure that abnormal current flows do not occur during the power-on sequence.

MB91520 Series

- **Observance of Safety Regulations and Standards**

Most countries in the world have established standards and regulations regarding safety, protection from electromagnetic interference, etc. Customers are requested to observe applicable regulations and standards in the design of products.

- **Fail-Safe Design**

Any semiconductor devices have inherently a certain rate of failure. You must protect against injury, damage or loss from such failures by incorporating safety design measures into your facility and equipment such as redundancy, fire protection, and prevention of over-current levels and other abnormal operating conditions.

- **Precautions Related to Usage of Devices**

FUJITSU SEMICONDUCTOR semiconductor devices are intended for use in standard applications (computers, office automation and other office equipment, industrial, communications, and measurement equipment, personal or household devices, etc.).

CAUTION: Customers considering the use of our products in special applications where failure or abnormal operation may directly affect human lives or cause physical injury or property damage, or where extremely high levels of reliability are demanded (such as aerospace systems, atomic energy controls, sea floor repeaters, vehicle operating controls, medical devices for life support, etc.) are requested to consult with sales representatives before such use. The company will not be responsible for damages arising from such use without prior approval.

2. Precautions for Package Mounting

Package mounting may be either lead insertion type or surface mount type. In either case, for heat resistance during soldering, you should only mount under FUJITSU SEMICONDUCTOR's recommended conditions. For detailed information about mount conditions, contact your sales representative.

- **Lead Insertion Type**

Mounting of lead insertion type packages onto printed circuit boards may be done by two methods: direct soldering on the board, or mounting by using a socket.

Direct mounting onto boards normally involves processes for inserting leads into through-holes on the board and using the flow soldering (wave soldering) method of applying liquid solder. In this case, the soldering process usually causes leads to be subjected to thermal stress in excess of the absolute ratings for storage temperature. Mounting processes should conform to FUJITSU SEMICONDUCTOR recommended mounting conditions.

If socket mounting is used, differences in surface treatment of the socket contacts and IC lead surfaces can lead to contact deterioration after long periods. For this reason it is recommended that the surface treatment of socket contacts and IC leads be verified before mounting.

- **Surface Mount Type**

Surface mount packaging has longer and thinner leads than lead-insertion packaging, and therefore leads are more easily deformed or bent. The use of packages with higher pin counts and narrower pin pitch results in increased susceptibility to open connections caused by deformed pins, or shorting due to solder bridges.

You must use appropriate mounting techniques. FUJITSU SEMICONDUCTOR recommends the solder reflow method, and has established a ranking of mounting conditions for each product. Users are advised to mount packages in accordance with FUJITSU SEMICONDUCTOR ranking of recommended conditions.

- **Lead-Free Packaging**

CAUTION: When ball grid array (BGA) packages with Sn-Ag-Cu balls are mounted using Sn-Pb eutectic soldering, junction strength may be reduced under some conditions of use.

- **Storage of Semiconductor Devices**

Because plastic chip packages are formed from plastic resins, exposure to natural environmental conditions will cause absorption of moisture. During mounting, the application of heat to a package that has absorbed moisture can cause surfaces to peel, reducing moisture resistance and causing packages to crack. To prevent, do the following:

- (1) Avoid exposure to rapid temperature changes, which cause moisture to condense inside the product. Store products in locations where temperature changes are slight.
- (2) Use dry boxes for product storage. Products should be stored below 70% relative humidity, and at temperatures between 5°C and 30°C.
When you open Dry Package that recommends humidity 40% to 70% relative humidity.
- (3) When necessary, FUJITSU SEMICONDUCTOR packages semiconductor devices in highly moisture-resistant aluminum laminate bags, with a silica gel desiccant. Devices should be sealed in their aluminum laminate bags for storage.
- (4) Avoid storing packages where they are exposed to corrosive gases or high levels of dust.

- **Baking**

Packages that have absorbed moisture may be de-moisturized by baking (heat drying). Follow the FUJITSU SEMICONDUCTOR recommended conditions for baking.

Condition: 125°C/24 h

- **Static Electricity**

Because semiconductor devices are particularly susceptible to damage by static electricity, you must take the following precautions:

- (1) Maintain relative humidity in the working environment between 40% and 70%. Use of an apparatus for ion generation may be needed to remove electricity.
- (2) Electrically ground all conveyors, solder vessels, soldering irons and peripheral equipment.
- (3) Eliminate static body electricity by the use of rings or bracelets connected to ground through high resistance (on the level of 1 MΩ).
Wearing of conductive clothing and shoes, use of conductive floor mats and other measures to minimize shock loads is recommended.
- (4) Ground all fixtures and instruments, or protect with anti-static measures.
- (5) Avoid the use of styrofoam or other highly static-prone materials for storage of completed board assemblies.

3. Precautions for Use Environment

Reliability of semiconductor devices depends on ambient temperature and other conditions as described above.

For reliable performance, do the following:

(1) Humidity

Prolonged use in high humidity can lead to leakage in devices as well as printed circuit boards. If high humidity levels are anticipated, consider anti-humidity processing.

(2) Discharge of Static Electricity

When high-voltage charges exist close to semiconductor devices, discharges can cause abnormal operation. In such cases, use anti-static measures or processing to prevent discharges.

(3) Corrosive Gases, Dust, or Oil

Exposure to corrosive gases or contact with dust or oil may lead to chemical reactions that will adversely affect the device. If you use devices in such conditions, consider ways to prevent such exposure or to protect the devices.

(4) Radiation, Including Cosmic Radiation

Most devices are not designed for environments involving exposure to radiation or cosmic radiation. Users should provide shielding as appropriate.

(5) Smoke, Flame

CAUTION: Plastic molded devices are flammable, and therefore should not be used near combustible substances. If devices begin to smoke or burn, there is danger of the release of toxic gases.

Customers considering the use of FUJITSU SEMICONDUCTOR products in other special environmental conditions should consult with sales representatives.

Please check the latest handling precautions at the following URL.

<http://edevice.fujitsu.com/fj/handling-e.pdf>

■ HANDLING DEVICES

This section explains the latch-up prevention and pin processing.

• For latch-up prevention

If a voltage higher than VCC or a voltage lower than VSS is applied to an I/O pin, or if a voltage exceeding the ratings is applied between VCC and VSS pins, a latch-up may occur in CMOS IC. If the latch-up occurs, the power supply current increases excessively and device elements may be damaged by heat. Take care to prevent any voltage from exceeding the maximum ratings in device application.

Also, the analog power supply (AVCC, AVRH) and analog input must not exceed the digital power supply (VCC) when the power supply to the analog system is turned on or off.

In the correct power-on sequence of the microcontroller, turn on the digital power supply (VCC) and analog power supplies (AVCC, AVRH) simultaneously. Or, turn on the digital power supply (VCC), and then turn on analog power supplies (AVCC, AVRH).

• Treatment of unused pins

If unused input pins are left open, they may cause a permanent damage to the device due to malfunction or latch-up. Connect at least a 2kΩ resistor to each of the unused pins for pull-up or pull-down processing.

Also, if I/O pins are not used, they must be set to the output state for releasing or they must be set to the input state and treated in the same way as for the input pins.

• Power supply pins

The device is designed to ensure that if the device contains multiple VCC or VSS pins, the pins that should be at the same potential are interconnected to prevent latch-up or other malfunctions. Further, connect these pins to an external power supply or ground to reduce unwanted radiation, prevent strobe signals from malfunctioning due to a raised ground level, and fulfill the total output current standard, etc. As shown in figure 1, all Vss power supply pins must be treated in the similar way. If multiple Vcc or Vss systems are connected, the device cannot operate correctly even within the guaranteed operating range.

Figure 1 Power Supply Input Pins

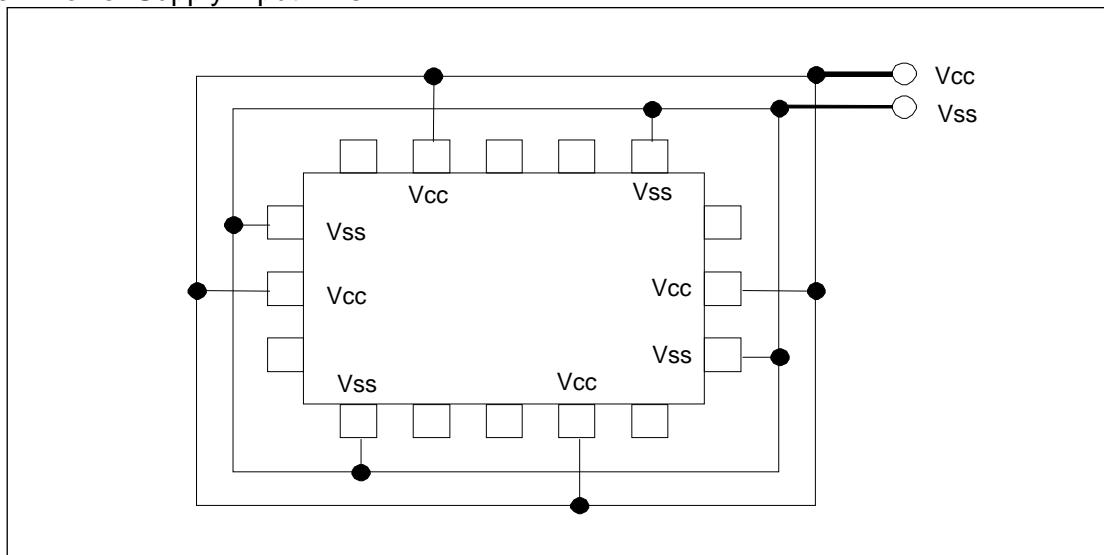

The power supply pins should be connected to VCC and VSS pins of this device at the low impedance from the power supply source.

In the area close to this device, a ceramic capacitor having the capacitance larger than the capacitor of C pin is recommended to use as a bypass capacitor between VCC and VSS pins.

MB91520 Series

- **Crystal oscillation circuit**

An external noise to the X0 or X1 pin may cause a device malfunction. The printed circuit board must be designed to lay out X0 and X1 pins, crystal oscillator (or ceramic resonator), and the bypass capacitor to be grounded to the close position to the device.

The printed circuit board artwork is recommended to surround the X0 and X1 pins by ground circuits.

- **Mode pins (MD1, MD0)**

Connect the MD1 and MD0 mode pins to the VCC or VSS pin directly. To prevent an erroneous selection of test mode caused by the noise, reduce the pattern length between each mode pin and VCC or VSS pin on the printed circuit board. Also, use the low-impedance pin connection.

- **During power-on**

To prevent a malfunction of the voltage step-down circuit built in the device, set the voltage rising time to have 50 μ s or longer (between 0.2V and 2.7V) during power-on.

- **Notes during PLL clock operation**

When the PLL clock is selected and if the oscillator is disconnected or if the input is stopped, this clock may continue to operate at the free running frequency of the self-oscillator circuit built in the PLL clock. This operation is not guaranteed.

- **Treatment of A/D converter power supply pins**

Connect the pins to have AVCC=AVRH=VCC and AVSS/AVRL=VSS even if the A/D converter is not used.

- **Notes on using external clock**

An external clock is not supported. None of the external direct clock input can be used for both main clock and sub clock.

- **Power-on sequence of A/D converter analog inputs**

Be sure to turn on the digital power supply (Vcc) first, and then turn on the A/D converter power supplies (AVcc, AVRH, AVRL) and analog inputs (AN0 to AN47). Also, turn off the A/D converter power supplies and analog inputs first, and then turn off the digital power supply (Vcc). When the AVRH pin voltage is turned on or off, it must not exceed AVCC. Even if a common analog input pin is used as an input port, its input voltage must not exceed AVcc. (However, the analog power supply and digital power supply can be turned on or off simultaneously.)

- **Treatment of C pin**

This device contains a voltage step-down circuit. A capacitor must always be connected to the C pin to assure the internal stabilization of the device. For the standard values, see the "Recommended Operating Conditions" of the latest data sheet.

Note: Please see the latest data sheet for a detailed specification of the operation voltage.

- **Function switching of a multiplexed port**

To switch between the port function and the multiplexed pin function, use the PFR (port function register). However, if a pin is also used for an external bus, its function is switched by the external bus setting. For details, see "I/O PORTS" in the hardware manual.

- **Low-power consumption mode**

To transit to the sleep mode, watch mode, stop mode, watch mode(power-off) or stop mode(power-off), follow the procedure explained in "Activating the sleep mode, watch mode, or stop mode" or "Activating the watch mode (power-off) or stop mode(power-off)" of "POWER CONSUMPTION CONTROL" in the hardware manual.

Take the following notes when using a monitor debugger.

- Do not set a break point for the low-power consumption transition program.
- Do not execute an operation step for the low-power consumption transition program.

- **Notes When Writing Data in a Register Having the Status Flag**

When writing data in the register that has a status flag (especially, an interrupt request flag) to control function, taking care not to clear its status flag erroneously must be followed.

The program must be written not to clear the flag to the status bit, and then to set the control bits to have the desired value.

Especially, if multiple control bits are used, the bit instruction cannot be used. (The bit instruction can access to a single bit only.) By the Byte, Half-word, or Word access, data is written to the control bits and status flag simultaneously. During this time, take care not to clear other bits (in this case, the bits of status flag) erroneously.

Note: These points can be ignored because the bit instructions are already taken the points into consideration.

MB91520 Series

■ BLOCK DIAGRAM

● MB91F522B, MB91F523B, MB91F524B, MB91F525B, MB91F526B

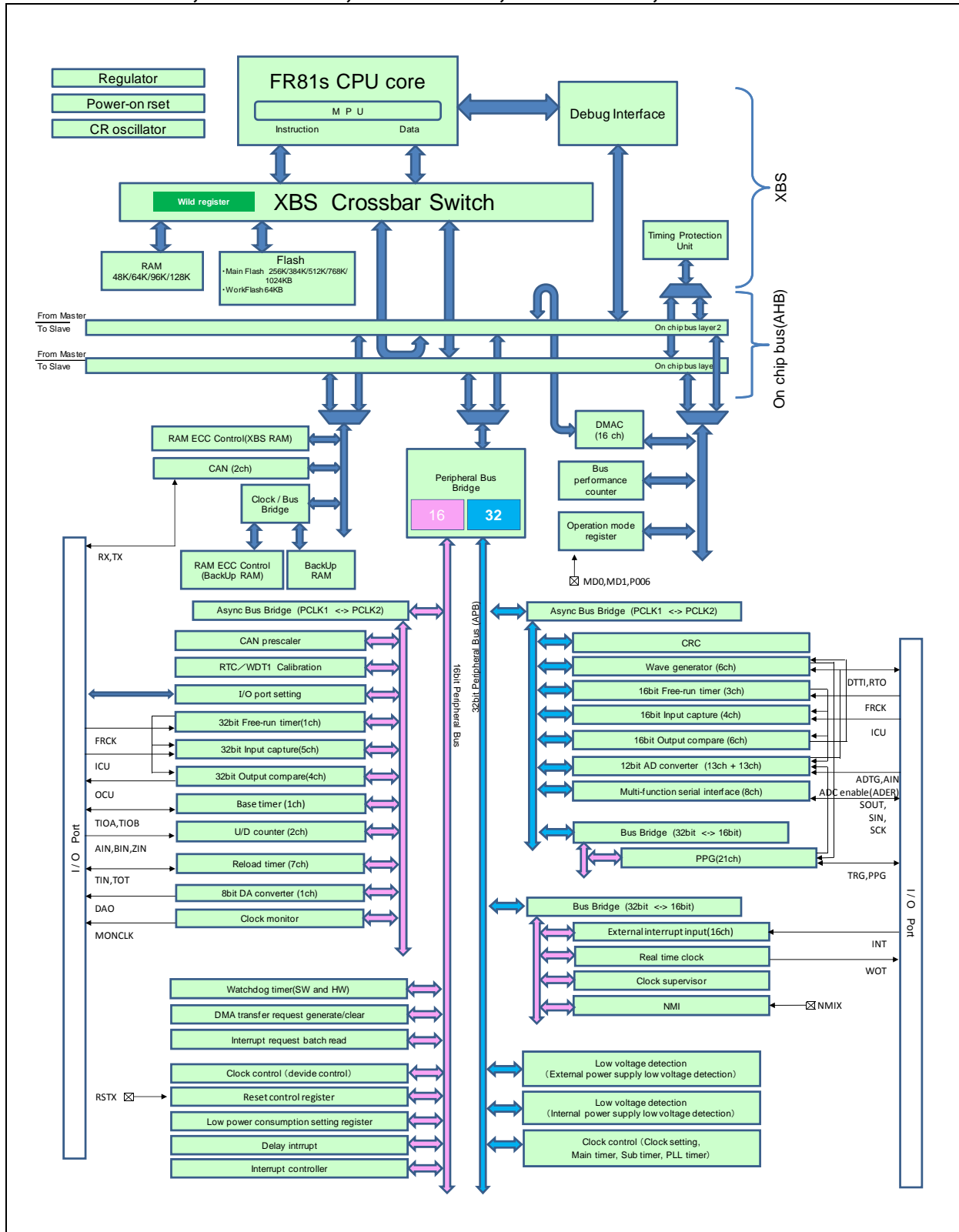

● MB91F522D, MB91F523D, MB91F524D, MB91F525D, MB91F526D

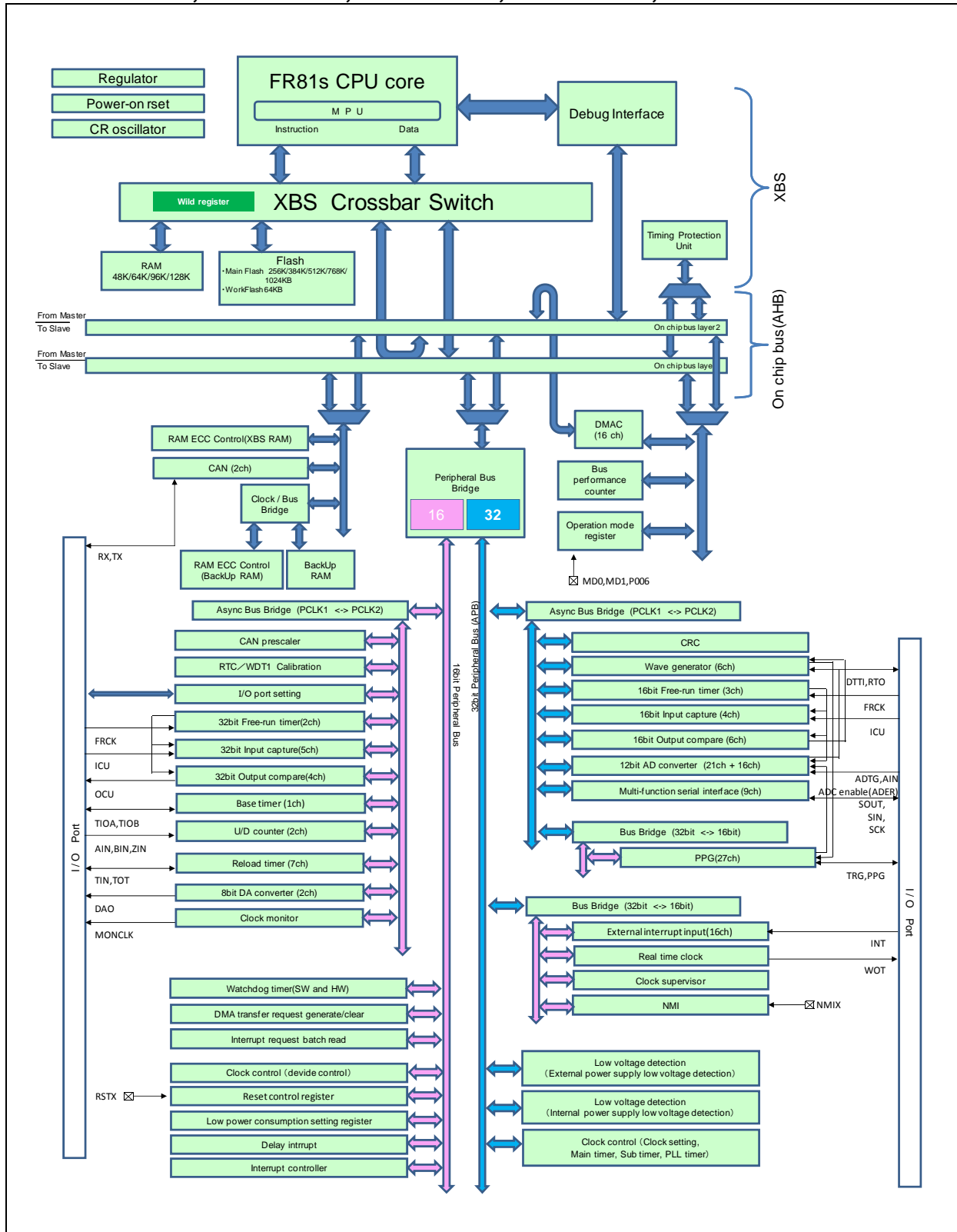

MB91520 Series

● MB91F522F, MB91F523F, MB91F524F, MB91F525F, MB91F526F

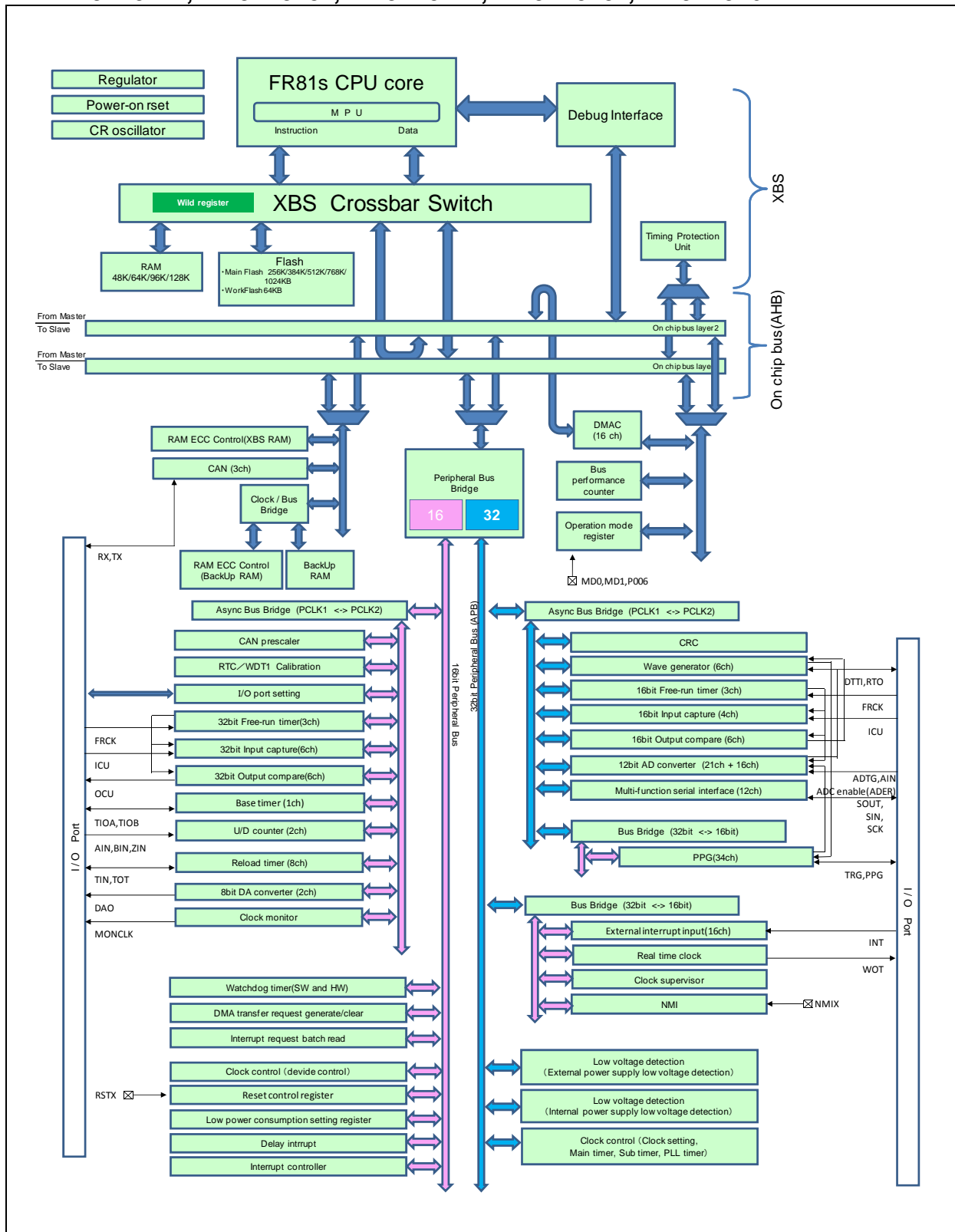

● MB91F522J, MB91F523J, MB91F524J, MB91F525J, MB91F526J

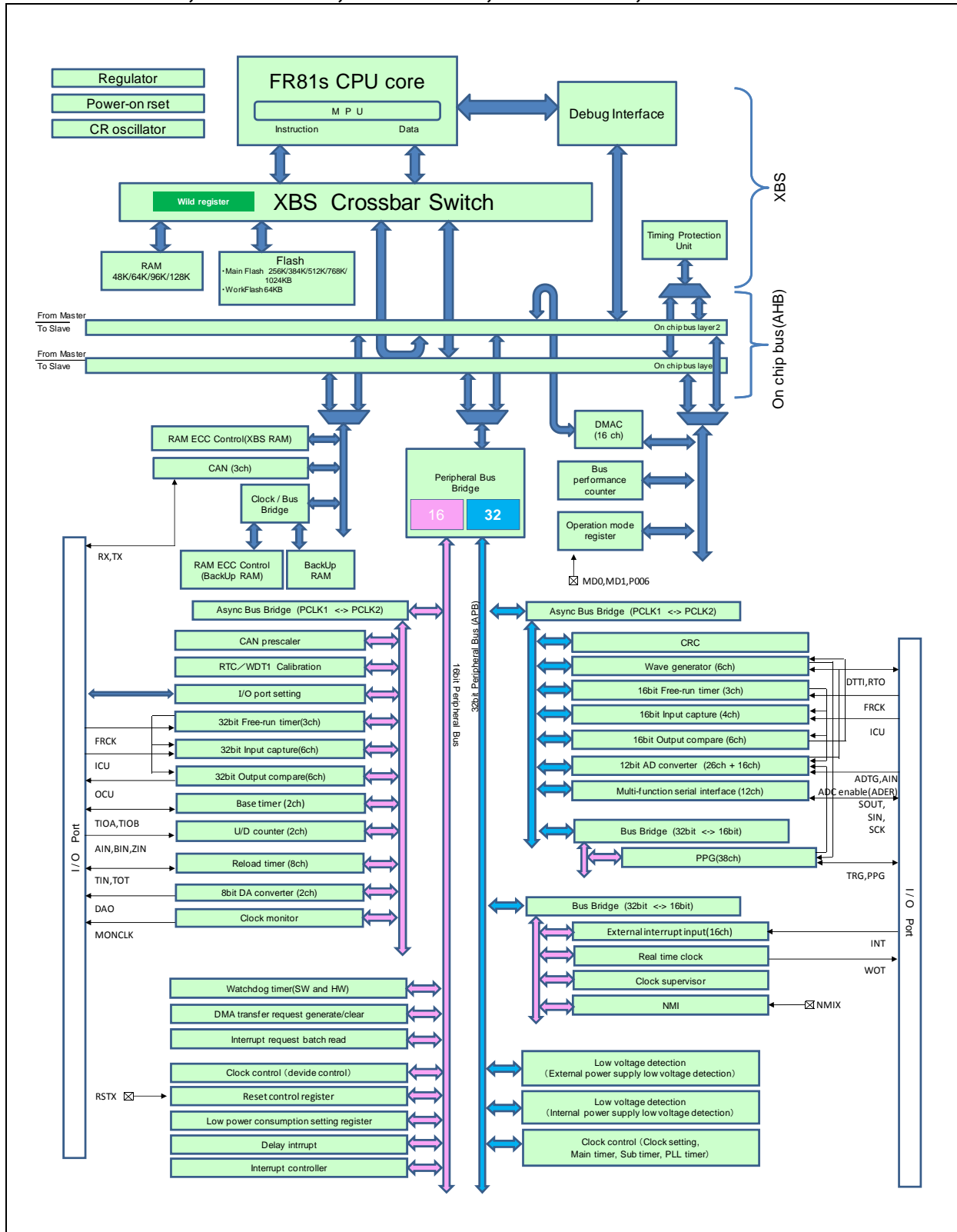

MB91520 Series

● MB91F522K, MB91F523K, MB91F524K, MB91F525K, MB91F526K

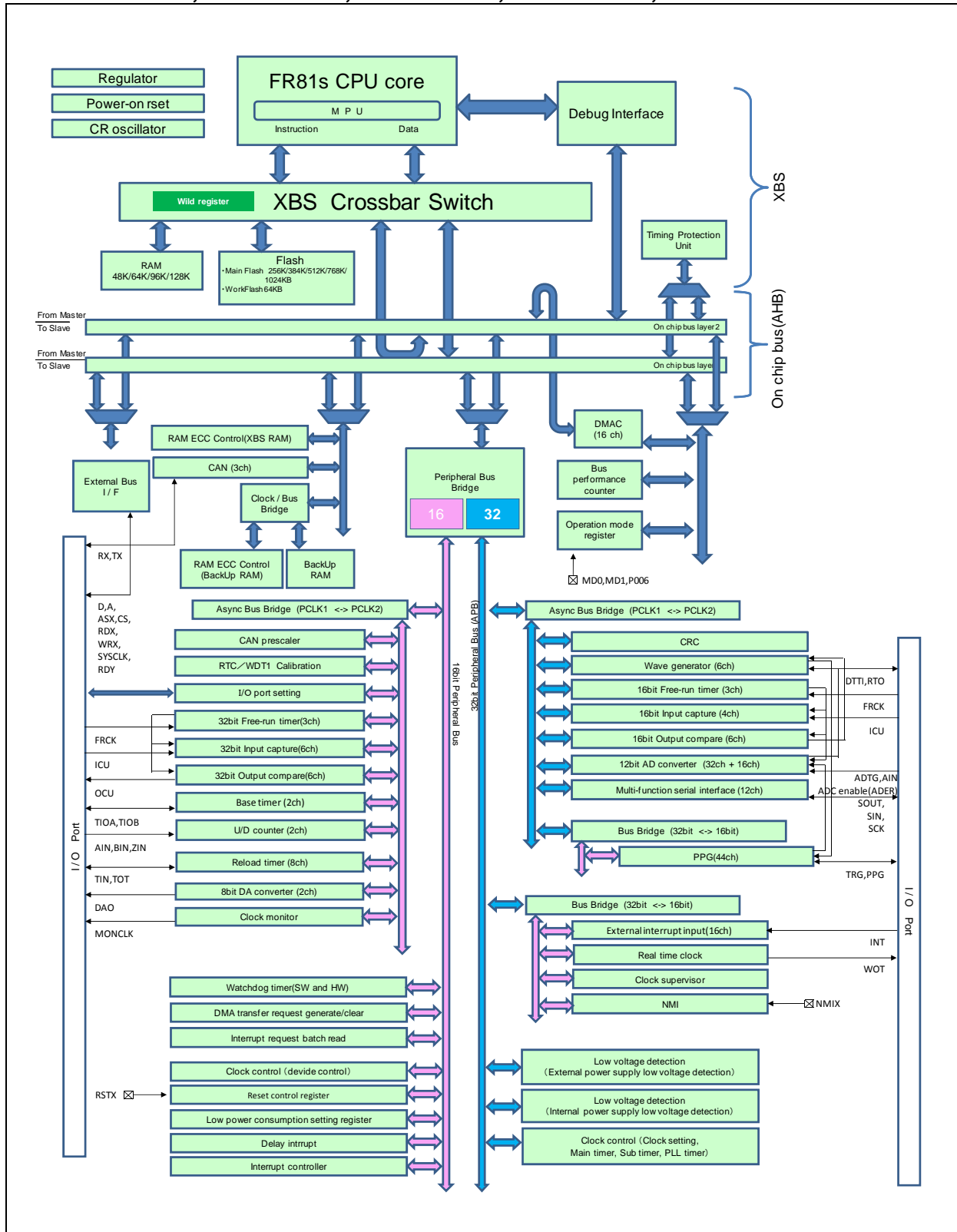

● MB91F522L, MB91F523L, MB91F524L, MB91F525L, MB91F526L

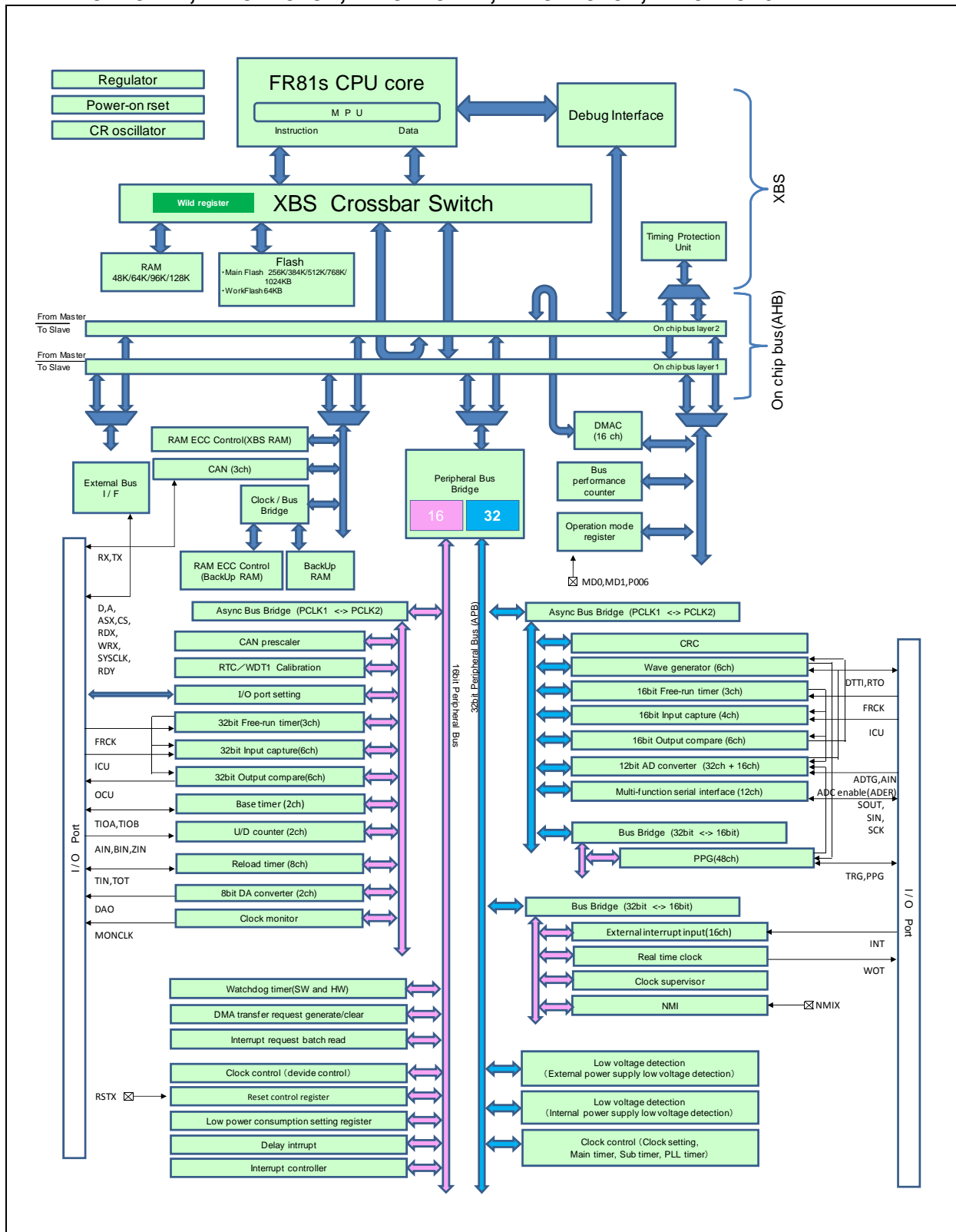

MB91520 Series

■ MEMORY MAP

● MB91F522, MB91F523, MB91F524

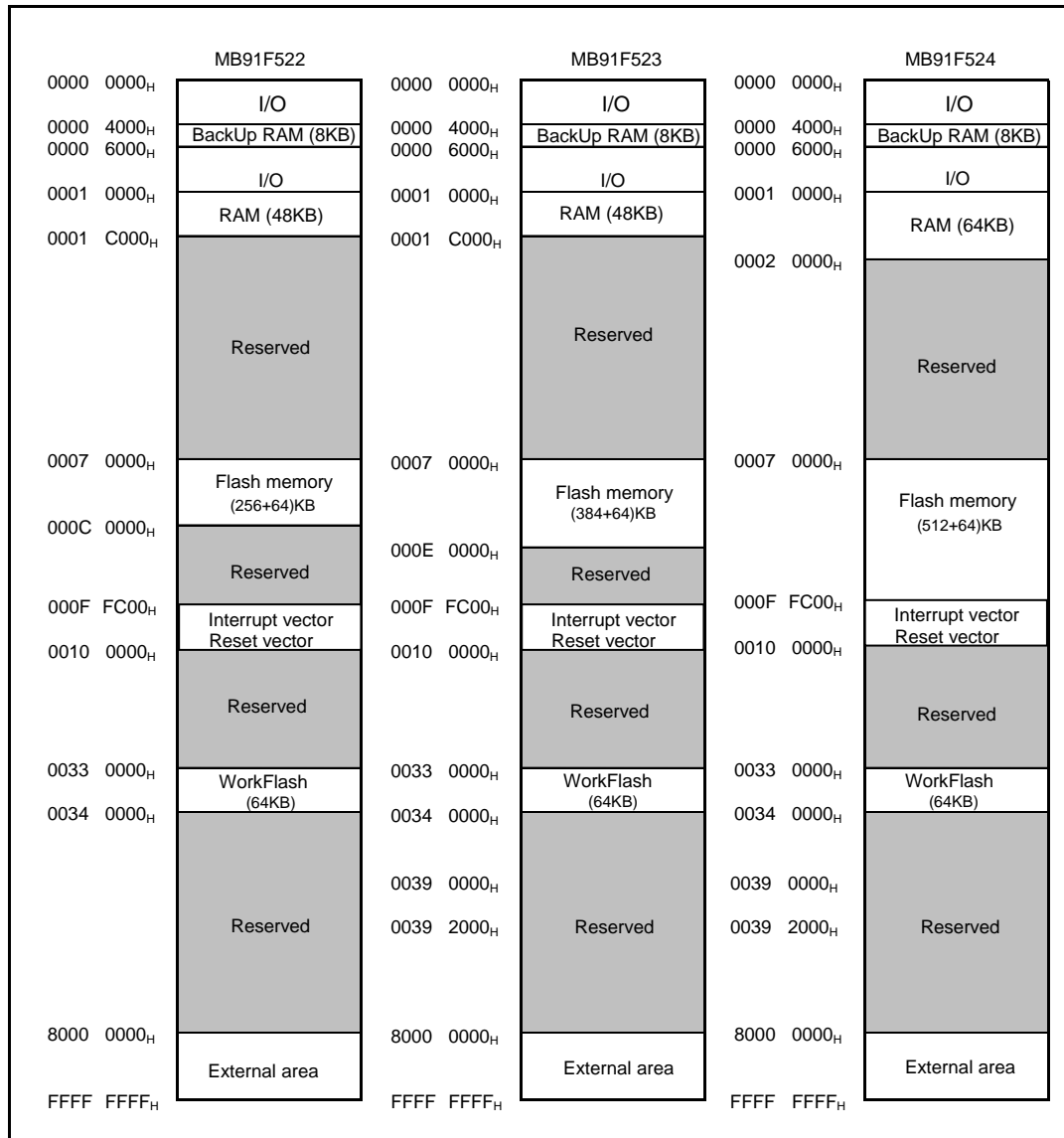

● MB91F525, MB91F526

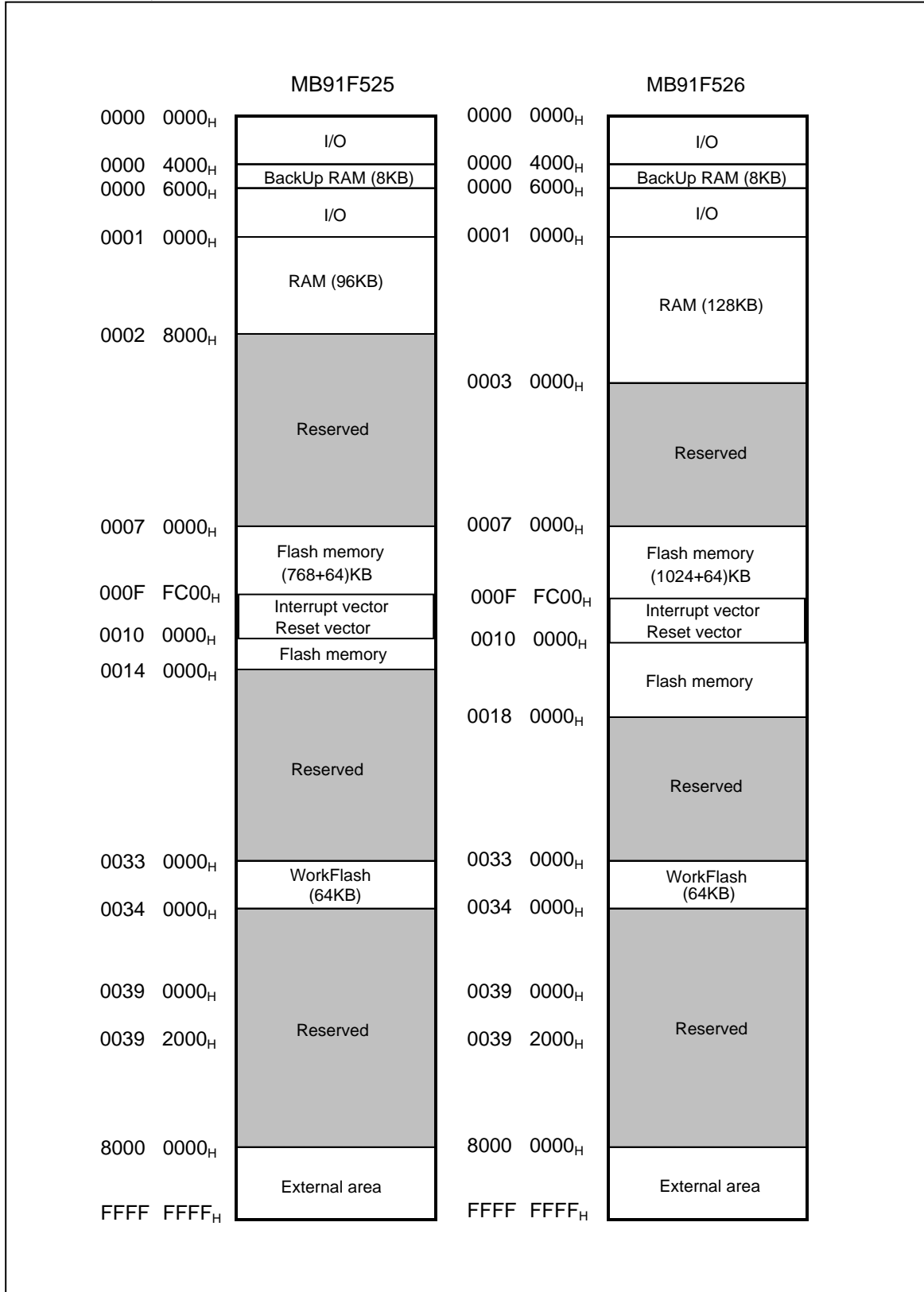

MB91520 Series

■ I/O MAP

The following I/O map shows the relationship between memory space and registers for peripheral resources.

Legend of I/O Map

Read/Write attribute (R: Read W: Write)

Address	Address offset value/ register name				Block
	+0	+1	+2	+3	
000090 _H	BT1TMR[R] H 0000000000000000		BT1TMCR[R/W]B,H,W 00000000 00000000		Base timer 1
000094 _H	-	BT1STC[R/W] B 00000000	-	-	
000098 _H	BT1PCSR/BT1PRL[R/W] H 0000000000000000		BT1PDU T/BT1PRLH/BT1DTBF[R/W] H 0000000000000000		
00009C _H	BTSEL[R/W] B ----000 0	-	BTSSSR[W] B,H -----11		
0000A0 _H	ADERH [R/W]B, H, W 00000000 00000000		ADERL [R/W]B, H, W 00000000 00000000		A/D converter
0000A4 _H	ADCS1 [R/W] B, H,W 00000000	ADCS0 [R/W] B, H,W 00000000	ADCR1 [R] B, H,W -----XX	ADCR0 [R] B, H,W XXXXX XXX	
0000A8 _H	ADCT1 [R/W] B, H,W 00010000	ADCT0 [R/W] B, H,W 00101100	ADSCH [R/W] B, H,W ---00000	ADECH [R/W] B, H,W ---00000	

Data access attribute
 B: Byte
 H: Half-word
 W: Word
 (Note)The access by the data access attribute not described is disabled.

Initial register value after reset

The initial register value after reset indicates as follows:

- "1": Initial value "1"
- "0": Initial value "0"
- "X": Initial value undefined
- "-": Reserved bit/Undefined bit
- "*": Initial value "0" or "1" according to the setting

Note: The access to addresses not described is disabled.

MB91520 Series

Address	Address offset value / Register name				Block
	+0	+1	+2	+3	
00000 _H	PDR00 [R/W] B,H,W XXXXXXXXXX	PDR01 [R/W] B,H,W XXXXXXXXXX	PDR02 [R/W] B,H,W XXXXXXXXXX	PDR03 [R/W] B,H,W XXXXXXXXXX	Port Data Register
000004 _H	PDR04 [R/W] B,H,W XXXXXXXXXX	PDR05 [R/W] B,H,W XXXXXXXXXX	PDR06 [R/W] B,H,W XXXXXXXXXX	PDR07 [R/W] B,H,W XXXXXXXXXX	
000008 _H	PDR08 [R/W] B,H,W XXXXXXXXXX	PDR09 [R/W] B,H,W XXXXXXXXXX	PDR10 [R/W] B,H,W XXXXXXXXXX	PDR11 [R/W] B,H,W XXXXXXXXXX	
00000C _H	PDR12 [R/W] B,H,W XXXXXXXXXX	PDR13 [R/W] B,H,W -XXXXXXXXX	PDR14 [R/W] B,H,W ---XXX--	PDR15 [R/W] B,H,W --XXXXXX	
000010 _H	—	—	—	—	
000014 _H	—	—	—	—	
000018 _H	PDR16 [R/W] B,H,W XXXXXXXXXX	PDR17 [R/W] B,H,W XXXXXXXXXX	PDR18 [R/W] B,H,W XXXXXXXXXX	PDR19 [R/W] B,H,W XXXXXXXXXX	
00001C _H to 000034 _H	—	—	—	—	Reserved
000038 _H	WDTECR0 [R/W] B,H,W ---00000	—	—	—	Watchdog Timer [S]
00003C _H	WDTCR0 [R/W] B,H,W -0--0000	WDTCPR0 [W] B,H,W 00000000	WDTCR1 [R] B,H,W ---0110	WDTCPR1 [W] B,H,W 00000000	
000040 _H	—	—	—	—	Reserved
000044 _H	DICR [R/W] B,H,W -----0	—	—	—	Delayed Interrupt
000048 _H to 00005C _H	—	—	—	—	Reserved
000060 _H	TMRLRA0 [R/W] H XXXXXXXXXX XXXXXXXXX		TMR0 [R] H XXXXXXXXXX XXXXXXXXX		Reload Timer 0
000064 _H	TMRLRB0 [R/W] H XXXXXXXXXX XXXXXXXXX		TMCSR0 [R/W] B,H,W 00000000 0-000000		
000068 _H	TMRLRA7 [R/W] H XXXXXXXXXX XXXXXXXXX		TMR7 [R] H XXXXXXXXXX XXXXXXXXX		Reload Timer 7
00006C _H	TMRLRB7 [R/W] H XXXXXXXXXX XXXXXXXXX		TMCSR7 [R/W] B,H,W 00000000 0-000000		
000070 _H	—	FRS8 [R/W] B,H,W --00-00 --00-00 --00-00			Free-run timer selection register 8
000074 _H	—	FRS9 [R/W] B,H,W --00-00 --00-00 --00-00			Free-run timer selection register 9
000078 _H	—	—	—	OCLS67 [R/W] B,H,W ----0000	OCU67 Output level control register

MB91520 Series

Address	Address offset value / Register name				Block
	+0	+1	+2	+3	
00007C _H	—	—	—	OCLS89 [R/W] B,H,W ----0000	OCU89 Output level control register
000080 _H	BT0TMR [R] H 00000000 00000000		BT0TMCR [R/W] H -000-00 -000-000		
000084 _H	BT0TMCR2 [R/W] B -----0	BT0STC [R/W] B -0-0-0-0	—	—	Base Timer 0
000088 _H	BT0PCSR/BT0PRL [R/W] H 00000000 00000000		BT0PDUT/BT0PRLH/BT0DTBF [R/W] H 00000000 00000000		
00008C _H	—	—	—	—	
000090 _H	BT1TMR [R] H 00000000 00000000		BT1TMCR [R/W] H -000-00 -000-000		Base Timer 1
000094 _H	BT1TMCR2 [R/W] B -----0	BT1STC [R/W] B -0-0-0-0	—	—	
000098 _H	BT1PCSR/BT1PRL [R/W] H 00000000 00000000		BT1PDUT/BT1PRLH/BT1DTBF [R/W] H 00000000 00000000		
00009C _H	BTSEL01 [R/W] B ----0000	—	BTSSSR [W] B,H -----11		Base Timer 0,1
0000A0 _H to 0000FC _H	—	—	—	—	Reserved
000100 _H	TMRLRA1 [R/W] H XXXXXXXX XXXXXXXX		TMR1 [R] H XXXXXXXX XXXXXXXX		Reload Timer 1
000104 _H	TMRLRB1 [R/W] H XXXXXXXX XXXXXXXX		TMCSR1 [R/W] B, H,W 00000000 0-000000		
000108 _H	TMRLRA2 [R/W] H XXXXXXXX XXXXXXXX		TMR2 [R] H XXXXXXXX XXXXXXXX		Reload Timer 2
00010C _H	TMRLRB2 [R/W] H XXXXXXXX XXXXXXXX		TMCSR2 [R/W] B,H,W 00000000 0-000000		
000110 _H	TMRLRA3 [R/W] H XXXXXXXX XXXXXXXX		TMR3 [R] H XXXXXXXX XXXXXXXX		Reload Timer 3
000114 _H	TMRLRB3 [R/W] H XXXXXXXX XXXXXXXX		TMCSR3 [R/W] B,H,W 00000000 0-000000		
000118 _H	MSCY4 [R] H,W XXXXXXXX XXXXXXXX XXXXXXXX XXXXXXXX				Input Capture 4,5 Cycle measurement data register 45
00011C _H	MSCY5 [R] H,W XXXXXXXX XXXXXXXX XXXXXXXX XXXXXXXX				
000120 _H	OCCP6 [R/W] W 00000000 00000000 00000000 00000000				Output Compare 6,7 32-bit OCU
000124 _H	OCCP7 [R/W] W 00000000 00000000 00000000 00000000				
000128 _H	—	—	OCSH67 [R/W] B,H,W ---0-00	OCSL67 [R/W] B,H,W 0000-00	

MB91520 Series

Address	Address offset value / Register name				Block
	+0	+1	+2	+3	
00012C _H	OCCP8 [R/W] W 00000000 00000000 00000000 00000000				Output Compare 8,9 32-bit OCU
000130 _H	OCCP9 [R/W] W 00000000 00000000 00000000 00000000				
000134 _H	—	—	OCSH89 [R/W] B,H,W ---0--00	OCSL89 [R/W] B,H,W 0000--00	
000138 _H to 0001B4 _H	—	—	—	—	Reserved
0001B8 _H	EPFR64 [R/W] B,H,W ----00-	EPFR65 [R/W] B,H,W 0000-000	EPFR66 [R/W] B,H,W --000000	EPFR67 [R/W] B,H,W ----0000	Extended port function register
0001BC _H	EPFR68 [R/W] B,H,W ----0000	EPFR69 [R/W] B,H,W ----0000	EPFR70 [R/W] B,H,W ---00000	EPFR71 [R/W] B,H,W -0-0-0-0	
0001C0 _H	EPFR72 [R/W] B,H,W 000000-0	EPFR73 [R/W] B,H,W 00000000	EPFR74 [R/W] B,H,W 00000000	EPFR75 [R/W] B,H,W 00000000	
0001C4 _H	EPFR76 [R/W] B,H,W 00000000	EPFR77 [R/W] B,H,W --000000	EPFR78 [R/W] B,H,W -----00	EPFR79 [R/W] B,H,W 00000000	
0001C8 _H	EPFR80 [R/W] B,H,W --000000	EPFR81 [R/W] B,H,W 00000000	EPFR82 [R/W] B,H,W 00000000	EPFR83 [R/W] B,H,W -0000000	
0001CC _H	EPFR84 [R/W] B,H,W 00000000	EPFR85 [R/W] B,H,W --000000	EPFR86 [R/W] B,H,W ---00000	EPFR87 [R/W] B,H,W -----00	
0001D0 _H	EPFR88 [R/W] B,H,W -----0	—	—	—	
0001D4 _H	—	—	—	—	
0001D8 _H	TMRLRA4 [R/W] H XXXXXXXX XXXXXXXX		TMR4 [R] H XXXXXXXX XXXXXXXX		Reload Timer 4
0001DC _H	TMRLRB4 [R/W] H XXXXXXXX XXXXXXXX		TMCSR4 [R/W] B, H, W 00000000 0-000000		
0001E0 _H to 0001EC _H	—	—	—	—	Reserved
0001F0 _H	TMRLRA5 [R/W] H XXXXXXXX XXXXXXXX		TMR5 [R] H XXXXXXXX XXXXXXXX		Reload Timer 5
0001F4 _H	TMRLRB5 [R/W] H XXXXXXXX XXXXXXXX		TMCSR5 [R/W] B, H, W 00000000 0-000000		
0001F8 _H	TMRLRA6 [R/W] H XXXXXXXX XXXXXXXX		TMR6 [R] H XXXXXXXX XXXXXXXX		Reload Timer 6
0001FC _H	TMRLRB6 [R/W] H XXXXXXXX XXXXXXXX		TMCSR6 [R/W] B, H, W 00000000 0-000000		
000200 _H to 000238 _H	—	—	—	—	Reserved
00023C _H	DACR0 [R/W] B,H,W -----0	DADR0 [R/W] B,H,W XXXXXXXX	DACR1 [R/W] B,H,W -----0	DADR1 [R/W] B,H,W XXXXXXXX	DA Converter

MB91520 Series

Address	Address offset value / Register name				Block
	+0	+1	+2	+3	
000240 _H	CPCLR3 [R/W] W 11111111 11111111 11111111 11111111				Free-run Timer 3 32-bit FRT
000244 _H	TCDT3 [R/W] W 00000000 00000000 00000000 00000000				
000248 _H	TCCSH3 [R/W] B,H,W 0----00	TCCSL3 [R/W] B,H,W -1-00000	—	—	
00024C _H	CPCLR4 [R/W] W 11111111 11111111 11111111 11111111				Free-run Timer 4 32-bit FRT
000250 _H	TCDT4 [R/W] W 00000000 00000000 00000000 00000000				
000254 _H	TCCSH4 [R/W] B,H,W 0----00	TCCSL4 [R/W] B,H,W -1-00000	—	—	
000258 _H to 0002C0 _H	—	—	—	—	Reserved
0002C4 _H to 0002FC _H	—	—	—	—	Reserved
000300 _H to 00030C _H	—	—	—	—	Reserved
000310 _H	—	—	MPUCR [R/W] H 000000-0 ----0100		MPU [S] (Only CPU core can access this area)
000314 _H	—	—	—	—	
000318 _H	—				
00031C _H	—	—	—		
000320 _H	DPMR [R] W XXXXXXXX XXXXXXXX XXXXXXXX XXXXXXXX				
000324 _H	—	—	DPVSR [R/W] H ----- 00000--0		
000328 _H	DEAR [R] W XXXXXXXX XXXXXXXX XXXXXXXX XXXXXXXX				
00032C _H	—	—	DESR [R/W] H ----- 00000--0		
000330 _H	PABR0 [R/W] W XXXXXXXX XXXXXXXX XXXXXXXX XXXX0000				
000334 _H	—	—	PACR0 [R/W] H 000000-0 00000--0		
000338 _H	PABR1 [R/W] W XXXXXXXX XXXXXXXX XXXXXXXX XXXX0000				
00033C _H	—	—	PACR1 [R/W] H 000000-0 00000--0		

MB91520 Series

Address	Address offset value / Register name				Block	
	+0	+1	+2	+3		
000340 _H	PABR2 [R/W] W XXXXXXXXXXXXXXXXXXXX0000				MPU [S] (Only CPU core can access this area)	
000344 _H	—	—	PACR2 [R/W] H 000000-0 00000--0			
000348 _H	PABR3 [R/W] W XXXXXXXXXXXXXXXXXXXX0000					
00034C _H	—	—	PACR3 [R/W] H 000000-0 00000--0			
000350 _H	PABR4 [R/W] W XXXXXXXXXXXXXXXXXXXX0000					
000354 _H	—	—	PACR4 [R/W] H 000000-0 00000--0			
000358 _H	PABR5 [R/W] W XXXXXXXXXXXXXXXXXXXX0000					
00035C _H	—	—	PACR5 [R/W] H 000000-0 00000--0			
000360 _H	PABR6 [R/W] W XXXXXXXXXXXXXXXXXXXX0000					
000364 _H	—	—	PACR6 [R/W] H 000000-0 00000--0			
000368 _H	PABR7 [R/W] W XXXXXXXXXXXXXXXXXXXX0000					
00036C _H	—	—	PACR7 [R/W] H 000000-0 00000--0			
000370 _H to 0003AC _H	—					Reserved [S]
0003B0 _H to 0003FC _H	—	—	—	—		Reserved [S]
000400 _H	ICSEL0 [R/W] B,H,W ----000	ICSEL1 [R/W] B,H,W ----000	ICSEL2 [R/W] B,H,W -----0	ICSEL3 [R/W] B,H,W -----0	DMA request generation and clear	
000404 _H	—	ICSEL5 [R/W] B,H,W ----000	ICSEL6 [R/W] B,H,W ---0000	ICSEL7 [R/W] B,H,W ---0000		
000408 _H	ICSEL8 [R/W] B,H,W -----00	ICSEL9 [R/W] B,H,W -----00	ICSEL10 [R/W] B,H,W -----00	ICSEL11 [R/W] B,H,W -----000		
00040C _H	—	ICSEL13 [R/W] B,H,W -----00	ICSEL14 [R/W] B,H,W -----00	ICSEL15 [R/W] B,H,W -----00		
000410 _H	ICSEL16 [R/W] B,H,W ----0000	ICSEL17 [R/W] B,H,W -----00	ICSEL18 [R/W] B,H,W ---00000	ICSEL19 [R/W] B,H,W -----000		
000414 _H	ICSEL20 [R/W] B,H,W ----000	ICSEL21 [R/W] B,H,W -----00	ICSEL22 [R/W] B,H,W -----00	ICSEL23 [R/W] B,H,W -----00		

MB91520 Series

Address	Address offset value / Register name				Block
	+0	+1	+2	+3	
000418 _H	IRPR0H [R] B,H,W 00-----	IRPR0L [R] B,H,W 00-----	IRPR1H [R] B,H,W 00-----	IRPR1L [R] B,H,W 00-----	Interrupt Request Batch Reading Register
00041C _H	—	—	IRPR3H [R] B,H,W 000000--	IRPR3L [R] B,H,W 000000--	
000420 _H	IRPR4H [R] B,H,W 0000----	IRPR4L [R] B,H,W 0000----	IRPR5H [R] B,H,W 0000----	IRPR5L [R] B,H,W 000-----	
000424 _H	IRPR6H [R] B,H,W --00----	IRPR6L [R] B,H,W 0000----	IRPR7H [R] B,H,W -0-00--	IRPR7L [R] B,H,W -----00	
000428 _H	IRPR8H [R] B,H,W --0-----	IRPR8L [R] B,H,W -0-----	IRPR9H [R] B,H,W -0-----	IRPR9L [R] B,H,W -0-----	
00042C _H	IRPR10H [R] B,H,W -0-----	IRPR10L [R] B,H,W -0-----	IRPR11H [R] B,H,W 0-----	IRPR11L [R] B,H,W 0-----	
000430 _H	IRPR12H [R] B,H,W --0000--	IRPR12L [R] B,H,W ---00--	IRPR13H [R] B,H,W 00-----	IRPR13L [R] B,H,W 00-----	
000434 _H	IRPR14H [R] B,H,W 00000000	IRPR14L [R] B,H,W 00000000	IRPR15H [R] B,H,W 000-----	IRPR15L [R] B,H,W 0000000-	
000438 _H	ICSEL24 [R/W] B,H,W -----00	ICSEL25 [R/W] B,H,W ---00000	ICSEL26 [R/W] B,H,W -----0	ICSEL27 [R/W] B,H,W -----0	DMA request generation and clear
00043C _H	—	—	—	—	Reserved [S]
000440 _H	ICR00 [R/W] B,H,W ---11111	ICR01 [R/W] B,H,W ---11111	ICR02 [R/W] B,H,W ---11111	ICR03 [R/W] B,H,W ---11111	Interrupt Controller [S]
000444 _H	ICR04 [R/W] B,H,W ---11111	ICR05 [R/W] B,H,W ---11111	ICR06 [R/W] B,H,W ---11111	ICR07 [R/W] B,H,W ---11111	
000448 _H	ICR08 [R/W] B,H,W ---11111	ICR09 [R/W] B,H,W ---11111	ICR10 [R/W] B,H,W ---11111	ICR11 [R/W] B,H,W ---11111	
00044C _H	ICR12 [R/W] B,H,W ---11111	ICR13 [R/W] B,H,W ---11111	ICR14 [R/W] B,H,W ---11111	ICR15 [R/W] B,H,W ---11111	
000450 _H	ICR16 [R/W] B,H,W ---11111	ICR17 [R/W] B,H,W ---11111	ICR18 [R/W] B,H,W ---11111	ICR19 [R/W] B,H,W ---11111	
000454 _H	ICR20 [R/W] B,H,W ---11111	ICR21 [R/W] B,H,W ---11111	ICR22 [R/W] B,H,W ---11111	ICR23 [R/W] B,H,W ---11111	
000458 _H	ICR24 [R/W] B,H,W ---11111	ICR25 [R/W] B,H,W ---11111	ICR26 [R/W] B,H,W ---11111	ICR27 [R/W] B,H,W ---11111	
00045C _H	ICR28 [R/W] B,H,W ---11111	ICR29 [R/W] B,H,W ---11111	ICR30 [R/W] B,H,W ---11111	ICR31 [R/W] B,H,W ---11111	
000460 _H	ICR32 [R/W] B,H,W ---11111	ICR33 [R/W] B,H,W ---11111	ICR34 [R/W] B,H,W ---11111	ICR35 [R/W] B,H,W ---11111	
000464 _H	ICR36 [R/W] B,H,W ---11111	ICR37 [R/W] B,H,W ---11111	ICR38 [R/W] B,H,W ---11111	ICR39 [R/W] B,H,W ---11111	
000468 _H	ICR40 [R/W] B,H,W ---11111	ICR41 [R/W] B,H,W ---11111	ICR42 [R/W] B,H,W ---11111	ICR43 [R/W] B,H,W ---11111	
00046C _H	ICR44 [R/W] B,H,W ---11111	ICR45 [R/W] B,H,W ---11111	ICR46 [R/W] B,H,W ---11111	ICR47 [R/W] B,H,W ---11111	

MB91520 Series

Address	Address offset value / Register name				Block
	+0	+1	+2	+3	
000470 _H to 00047C _H	—	—	—	—	Reserved [S]
000480 _H	RSTRR [R] B,H,W XXXX--XX	RSTCR [R/W] B,H,W 111----0	STBCR [R/W] B,H,W * 000---11	—	Reset Control [S] Power Control [S] *: Writing STBCR by DMA is forbidden
000484 _H	—	—	—	—	Reserved [S]
000488 _H	DIVR0 [R/W] B,H,W 000-----	DIVR1 [R/W] B,H,W 0001----	DIVR2 [R/W] B,H,W 0011----	—	Clock Control [S]
00048C _H	—	—	—	—	Reserved [S]
000490 _H	IORR0 [R/W] B,H,W -0000000	IORR1 [R/W] B,H,W -0000000	IORR2 [R/W] B,H,W -0000000	IORR3 [R/W] B,H,W -0000000	DMA request by peripheral [S]
000494 _H	IORR4 [R/W] B,H,W -0000000	IORR5 [R/W] B,H,W -0000000	IORR6 [R/W] B,H,W -0000000	IORR7 [R/W] B,H,W -0000000	
000498 _H	IORR8 [R/W] B,H,W -0000000	IORR9 [R/W] B,H,W -0000000	IORR10 [R/W] B,H,W -0000000	IORR11 [R/W] B,H,W -0000000	
00049C _H	IORR12 [R/W] B,H,W -0000000	IORR13 [R/W] B,H,W -0000000	IORR14 [R/W] B,H,W -0000000	IORR15 [R/W] B,H,W -0000000	
0004A0 _H	—	—	—	—	Reserved
0004A4 _H	CANPRE [R/W] B,H,W --00000	—	—	—	CAN prescaler
0004A8 _H	—	—	CSCFG[R/W]B,H,W ---0----	CMCFG[R/W]B,H,W 00000000	Clock monitor control register
0004AC _H	ADERH0[R/W] B,H 11111111 11111111		ADERL0[R/W] B,H 11111111 11111111		Analog input control register 0
0004B0 _H	—		ADERL1[R/W] B,H 11111111 11111111		Analog input control register 1
0004B4 _H	—	—	—	—	Reserved
0004B8 _H	CUCR0 [R/W] B,H,W ----- ---0--00		CUTD0 [R/W] B,H,W 10000000 00000000		RTC/WDT1 calibration
0004BC _H	CUTR0 [R] B,H,W ----- 00000000 00000000 00000000				
0004C0 _H	—	—	—	—	
0004C4 _H	CUCR1 [R/W] B,H,W ----- ---0--00		CUTD1 [R/W] B,H,W 11000011 01010000		
0004C8 _H	CUTR1 [R] B,H,W ----- 00000000 00000000 00000000				
0004CC _H to 00050C _H	—	—	—	—	Reserved

MB91520 Series

Address	Address offset value / Register name				Block
	+0	+1	+2	+3	
000510 _H	CSELR [R/W] B,H,W 001---00	CMONR [R] B,H,W 001---00	MTMCR [R/W] B,H,W 00001111	STMCR [R/W] B,H,W 0000-111	Clock Control [S]
000514 _H	PLLCR [R/W] B,H,W ----- 11110000		CSTBR [R/W] B,H,W -0000000	PTMCR [R/W] B,H,W 00-----	
000518 _H	—	—	CPUAR [R/W] B,H,W 0---XXX	—	Reset Control [S]
00051C _H	—	—	—	—	Reserved [S]
000520 _H	CCPSSELR [R/W] B,H,W -----0	—	—	CCPSDIVR [R/W] B,H,W -000-000	Clock Control 2 [S]
000524 _H	—	CCPLLFB [R/W] B,H,W -0000000	CCSSFBR0 [R/W] B,H,W --000000	CCSSFBR1 [R/W] B,H,W ---00000	
000528 _H	—	CCSSCCR0 [R/W] B,H,W ---0000	CCSSCCR1 [R/W] H,W 000-----		
00052C _H	—	CCCGRCR0 [R/W] B,H,W 00---00	CCCGRCR1 [R/W] B,H,W 00000000	CCCGRCR2 [R/W] B,H,W 00000000	
000530 _H	CCRTSELR [R/W] B,H,W 0-----0	—	CCPMUCR0 [R/W] B,H,W 0-----00	CCPMUCR1 [R/W] B,H,W 0--00000	
000534 _H to 00054C _H	—	—	—	—	Reserved
000550 _H	EIRR0 [R/W] B,H,W XXXXXXXXXX	ENIR0 [R/W] B,H,W 00000000	ELVR0 [R/W] B,H,W 00000000 00000000		External Interrupt (INT0 to 7)
000554 _H	EIRR1 [R/W] B,H,W XXXXXXXXXX	ENIR1 [R/W] B,H,W 00000000	ELVR1 [R/W] B,H,W 00000000 00000000		External Interrupt (INT8 to 15)
000558 _H	—	—	—	—	Reserved
00055C _H	—	—	WTDR [R/W] H 00000000 00000000		Real Time Clock (RTC)
000560 _H	—	WTCRH [R/W] B -----00	WTCRM [R/W] B,H 00000000	WTCRL [R/W] B,H ----00-0	
000564 _H	—	WTBRH [R/W] B --XXXXXX	WTBRM [R/W] B XXXXXXXXXX	WTBRL [R/W] B XXXXXXXXXX	
000568 _H	WTHR [R/W] B,H ---00000	WTMR [R/W] B,H --000000	WTSR [R/W] B --000000	—	
00056C _H	—	CSVCR [R/W] B 000111--	—	—	Clock Supervisor
000570 _H to 00057C _H	—	—	—	—	Reserved

MB91520 Series

Address	Address offset value / Register name				Block
	+0	+1	+2	+3	
000580 _H	REGSEL [R/W] B,H,W 0110011-	—	—	—	Regulator Control / Low Voltage Detection
000584 _H	LVD5R [R/W] B,H,W -----1	LVD5F [R/W] B,H,W 00000001	LVD [R/W] B,H,W 01000--0	—	
000588 _H to 00058C _H	—	—	—	—	Reserved
000590 _H	PMUSTR [R/W] B,H,W 0----1X	PMUCTLR [R/W] B,H,W 0-00----	PWRTMCTL [R/W] B,H,W ----011	—	PMU
000594 _H	PMUINTF0 [R/W] B,H,W 00000000	PMUINTF1 [R/W] B,H,W 00000000	PMUINTF2 [R/W] B,H,W 0000----	—	
000598 _H	—	—	—	—	
00059C _H to 0005BC _H	—	—	—	—	Reserved
0005C0 _H to 0005FC _H	—	—	—	—	Reserved
000600 _H	ASR0 [R/W] W 00000000 00000000 ----- 1111-001				External Bus Interface [S]
000604 _H	ASR1 [R/W] W XXXXXXXX XXXXXXXX ----- XXXX-XX0				
000608 _H	ASR2 [R/W] W XXXXXXXX XXXXXXXX ----- XXXX-XX0				
00060C _H	ASR3 [R/W] W XXXXXXXX XXXXXXXX ----- XXXX-XX0				
000610 _H to 00063C _H	—	—	—	—	Reserved [S]
000640 _H	ACR0 [R/W] W -----01--00--				External Bus Interface [S]
000644 _H	ACR1 [R/W] W -----XX--XX--				
000648 _H	ACR2 [R/W] W -----XX--XX--				
00064C _H	ACR3 [R/W] W -----XX--XX--				
000650 _H to 00067C _H	—	—	—	—	Reserved [S]
000680 _H	AWR0 [R/W] W ----1111 00000000 11110000 00000-0-				External Bus Interface [S]
000684 _H	AWR1 [R/W] W ----XXXX XXXXXXXX XXXXXXXX XXXXX-X-				

MB91520 Series

Address	Address offset value / Register name				Block
	+0	+1	+2	+3	
000688 _H	AWR2 [R/W] W ----XXXX XXXXXXXXXX XXXXXXXXXX XXXXXX-X-				External Bus Interface [S]
00068C _H	AWR3 [R/W] W ----XXXX XXXXXXXXXX XXXXXXXXXX XXXXXX-X-				
000690 _H to 0006FC _H	—	—	—	—	Reserved [S]
000700 _H to 00070C _H	—	—	—	—	Reserved
000710 _H	BPC CRA [R/W] B 00000000	BPC CRB [R/W] B 00000000	BPC CRC [R/W] B 00000000	—	Bus Performance Counter
000714 _H	BPCTRA [R/W] W 00000000 00000000 00000000 00000000				
000718 _H	BPCTRB [R/W] W 00000000 00000000 00000000 00000000				
00071C _H	BPCTRC [R/W] W 00000000 00000000 00000000 00000000				
000720 _H to 0007F8 _H	—	—	—	—	Reserved
0007FC _H	BMODR [R] B, H, W XXXXXXXX	—	—	—	Mode Register
000800 _H to 00083C _H	—	—	—	—	Reserved [S]
000840 _H	FCTL R [R/W] H -0--1000 0--0----		—	FSTR [R/W] B ----001	Flash Memory Register [S]
000844 _H to 000854 _H	—	—	—	—	Reserved [S]
000858 _H	—	—	WREN [R/W] H 00000000 00000000		Wild Register [S]
00085C _H to 00087C _H	—	—	—	—	Reserved [S]
000880 _H	WRAR00 [R/W] W ----- --XXXXXXXX XXXXXXXXXX XXXXXXX--				Wild Register [S]
000884 _H	WRDR00 [R/W] W XXXXXXXX XXXXXXXXXX XXXXXXXXXX XXXXXXXXXX				
000888 _H	WRAR01 [R/W] W ----- --XXXXXXXX XXXXXXXXXX XXXXXXX--				
00088C _H	WRDR01 [R/W] W XXXXXXXX XXXXXXXXXX XXXXXXXXXX XXXXXXXXXX				
000890 _H	WRAR02 [R/W] W ----- --XXXXXXXX XXXXXXXXXX XXXXXXX--				
000894 _H	WRDR02 [R/W] W XXXXXXXX XXXXXXXXXX XXXXXXXXXX XXXXXXXXXX				

MB91520 Series

Address	Address offset value / Register name				Block
	+0	+1	+2	+3	
000898 _H	WRAR03 [R/W] W ----- --XXXXXXXX XXXXXXXXXX XXXXXXX--				Wild Register [S]
00089C _H	WRDR03 [R/W] W XXXXXXXXXXXXXXXXXXXXXXXXXXXXXXXX				
0008A0 _H	WRAR04 [R/W] W ----- --XXXXXXXX XXXXXXXXXX XXXXXXX--				
0008A4 _H	WRDR04 [R/W] W XXXXXXXXXXXXXXXXXXXXXXXXXXXXXXXX				
0008A8 _H	WRAR05 [R/W] W ----- --XXXXXXXX XXXXXXXXXX XXXXXXX--				
0008AC _H	WRDR05 [R/W] W XXXXXXXXXXXXXXXXXXXXXXXXXXXXXXXX				
0008B0 _H	WRAR06 [R/W] W ----- --XXXXXXXX XXXXXXXXXX XXXXXXX--				
0008B4 _H	WRDR06 [R/W] W XXXXXXXXXXXXXXXXXXXXXXXXXXXXXXXX				
0008B8 _H	WRAR07 [R/W] W ----- --XXXXXXXX XXXXXXXXXX XXXXXXX--				
0008BC _H	WRDR07 [R/W] W XXXXXXXXXXXXXXXXXXXXXXXXXXXXXXXX				
0008C0 _H	WRAR08 [R/W] W ----- --XXXXXXXX XXXXXXXXXX XXXXXXX--				
0008C4 _H	WRDR08 [R/W] W XXXXXXXXXXXXXXXXXXXXXXXXXXXXXXXX				
0008C8 _H	WRAR09 [R/W] W ----- --XXXXXXXX XXXXXXXXXX XXXXXXX--				
0008CC _H	WRDR09 [R/W] W XXXXXXXXXXXXXXXXXXXXXXXXXXXXXXXX				
0008D0 _H	WRAR10 [R/W] W ----- --XXXXXXXX XXXXXXXXXX XXXXXXX--				
0008D4 _H	WRDR10 [R/W] W XXXXXXXXXXXXXXXXXXXXXXXXXXXXXXXX				
0008D8 _H	WRAR11 [R/W] W ----- --XXXXXXXX XXXXXXXXXX XXXXXXX--				
0008DC _H	WRDR11 [R/W] W XXXXXXXXXXXXXXXXXXXXXXXXXXXXXXXX				
0008E0 _H	WRAR12 [R/W] W ----- --XXXXXXXX XXXXXXXXXX XXXXXXX--				
0008E4 _H	WRDR12 [R/W] W XXXXXXXXXXXXXXXXXXXXXXXXXXXXXXXX				
0008E8 _H	WRAR13 [R/W] W ----- --XXXXXXXX XXXXXXXXXX XXXXXXX--				
0008EC _H	WRDR13 [R/W] W XXXXXXXXXXXXXXXXXXXXXXXXXXXXXXXX				
0008F0 _H	WRAR14 [R/W] W ----- --XXXXXXXX XXXXXXXXXX XXXXXXX--				

MB91520 Series

Address	Address offset value / Register name				Block
	+0	+1	+2	+3	
0008F4 _H	WRDR14 [R/W] W XXXXXXXXXXXXXXXXXXXXXXXXXXXXXXXX				Wild Register [S]
0008F8 _H	WRAR15 [R/W] W -----XXXXXXXXXXXXXXXXXXXX--				
0008FC _H	WRDR15 [R/W] W XXXXXXXXXXXXXXXXXXXXXXXXXXXXXXXX				
000900 _H	TPUUNLOCK [R/W] W 00000000 00000000 00000000 00000000				Time Protection Unit [S]
000904 _H	TPULST [R] B,H,W -----0	—	TPUVST [R/W] B,H,W -----000	—	
000908 _H	TPUCFG [R/W] B,H,W -----0 0-000000 -----0				
00090C _H	TPUTIR [R] B,H,W 00000000	—	—	—	
000910 _H	TPUTST [R] B,H,W 00000000	—	—	—	
000914 _H	TPUTIE [R/W] B,H,W 00000000	—	—	—	
000918 _H	TPUTMID [R] B,H,W 00000000 00000000 00000000 00000000				
00091C _H to 00092C _H	—	—	—	—	
000930 _H	TPUTCN00 [R/W] B,H,W 000000-- 00000000 00000000 00000000				
000934 _H	TPUTCN01 [R/W] B,H,W 000000-- 00000000 00000000 00000000				
000938 _H	TPUTCN02 [R/W] B,H,W 000000-- 00000000 00000000 00000000				
00093C _H	TPUTCN03 [R/W] B,H,W 000000-- 00000000 00000000 00000000				
000940 _H	TPUTCN04 [R/W] B,H,W 000000-- 00000000 00000000 00000000				
000944 _H	TPUTCN05 [R/W] B,H,W 000000-- 00000000 00000000 00000000				
000948 _H	TPUTCN06 [R/W] B,H,W 000000-- 00000000 00000000 00000000				
00094C _H	TPUTCN07 [R/W] B,H,W 000000-- 00000000 00000000 00000000				
000950 _H	TPUTCN10 [R/W] B,H,W --00000	—	—	—	
000954 _H	TPUTCN11 [R/W] B,H,W --00000	—	—	—	
000958 _H	TPUTCN12 [R/W] B,H,W --00000	—	—	—	

MB91520 Series

Address	Address offset value / Register name				Block
	+0	+1	+2	+3	
00095C _H	TPUTCN13 [R/W] B,H,W --00000	—	—	—	Time Protection Unit [S]
000960 _H	TPUTCN14 [R/W] B,H,W --00000	—	—	—	
000964 _H	TPUTCN15 [R/W] B,H,W --00000	—	—	—	
000968 _H	TPUTCN16 [R/W] B,H,W --00000	—	—	—	
00096C _H	TPUTCN17 [R/W] B,H,W --00000	—	—	—	
000970 _H	TPUTCC0 [R] B,H,W ----- 00000000 00000000 00000000				
000974 _H	TPUTCC1 [R] B,H,W ----- 00000000 00000000 00000000				
000978 _H	TPUTCC2 [R] B,H,W ----- 00000000 00000000 00000000				
00097C _H	TPUTCC3 [R] B,H,W ----- 00000000 00000000 00000000				
000980 _H	TPUTCC4 [R] B,H,W ----- 00000000 00000000 00000000				
000984 _H	TPUTCC5 [R] B,H,W ----- 00000000 00000000 00000000				
000988 _H	TPUTCC6 [R] B,H,W ----- 00000000 00000000 00000000				
00098C _H	TPUTCC7 [R] B,H,W ----- 00000000 00000000 00000000				
000990 _H to 0009FC _H	—	—	—	—	
000A00 _H to 000BEC _H	—	—	—	—	Reserved
000BF0 _H	HSCFR [R/W] B,H,W ----- -00 00000000 00000000				OCDU
000BF4 _H	—	—	—	—	
000BF8 _H	—	—	MBR [R/W] B,H,W 00----- XXXXXXXX		
000BFC _H	—	—	UER [W] B,H,W ----- -X		
000C00 _H	DCCR0 [R/W] W 0----000 --00--00 00000000 0-000000				DMA Controller [S]
000C04 _H	DCSR0 [R/W] H 0----- -000		DTCR0 [R/W] H 00000000 00000000		

MB91520 Series

Address	Address offset value / Register name				Block
	+0	+1	+2	+3	
000C08 _H	DSAR0 [R/W] W XXXXXXXXXXXXXXXXXXXXXXXXXXXXXXXX				DMA Controller [S]
000C0C _H	DDAR0 [R/W] W XXXXXXXXXXXXXXXXXXXXXXXXXXXXXXXX				
000C10 _H	DCCR1 [R/W] W 0----000 --00--00 00000000 0-000000				
000C14 _H	DCSR1 [R/W] H 0-----000		DTCR1 [R/W] H 00000000 00000000		
000C18 _H	DSAR1 [R/W] W XXXXXXXXXXXXXXXXXXXXXXXXXXXXXXXX				
000C1C _H	DDAR1 [R/W] W XXXXXXXXXXXXXXXXXXXXXXXXXXXXXXXX				
000C20 _H	DCCR2 [R/W] W 0----000 --00--00 00000000 0-000000				
000C24 _H	DCSR2 [R/W] H 0-----000		DTCR2 [R/W] H 00000000 00000000		
000C28 _H	DSAR2 [R/W] W XXXXXXXXXXXXXXXXXXXXXXXXXXXXXXXX				
000C2C _H	DDAR2 [R/W] W XXXXXXXXXXXXXXXXXXXXXXXXXXXXXXXX				
000C30 _H	DCCR3 [R/W] W 0----000 --00--00 00000000 0-000000				
000C34 _H	DCSR3 [R/W] H 0-----000		DTCR3 [R/W] H 00000000 00000000		
000C38 _H	DSAR3 [R/W] W XXXXXXXXXXXXXXXXXXXXXXXXXXXXXXXX				
000C3C _H	DDAR3 [R/W] W XXXXXXXXXXXXXXXXXXXXXXXXXXXXXXXX				
000C40 _H	DCCR4 [R/W] W 0----000 --00--00 00000000 0-000000				
000C44 _H	DCSR4 [R/W] H 0-----000		DTCR4 [R/W] H 00000000 00000000		
000C48 _H	DSAR4 [R/W] W XXXXXXXXXXXXXXXXXXXXXXXXXXXXXXXX				
000C4C _H	DDAR4 [R/W] W XXXXXXXXXXXXXXXXXXXXXXXXXXXXXXXX				
000C50 _H	DCCR5 [R/W] W 0----000 --00--00 00000000 0-000000				
000C54 _H	DCSR5 [R/W] H 0-----000		DTCR5 [R/W] H 00000000 00000000		
000C58 _H	DSAR5 [R/W] W XXXXXXXXXXXXXXXXXXXXXXXXXXXXXXXX				
000C5C _H	DDAR5 [R/W] W XXXXXXXXXXXXXXXXXXXXXXXXXXXXXXXX				
000C60 _H	DCCR6 [R/W] W 0----000 --00--00 00000000 0-000000				
000C64 _H	DCSR6 [R/W] H 0-----000		DTCR6 [R/W] H 00000000 00000000		

MB91520 Series

Address	Address offset value / Register name				Block
	+0	+1	+2	+3	
000C68 _H	DSAR6 [R/W] W XXXXXXXXXXXXXXXXXXXXXXXXXXXXXXXX				DMA Controller [S]
000C6C _H	DDAR6 [R/W] W XXXXXXXXXXXXXXXXXXXXXXXXXXXXXXXX				
000C70 _H	DCCR7 [R/W] W 0---000 --00--00 00000000 0-000000				
000C74 _H	DCSR7 [R/W] H 0-----000		DTCR7 [R/W] H 00000000 00000000		
000C78 _H	DSAR7 [R/W] W XXXXXXXXXXXXXXXXXXXXXXXXXXXXXXXX				
000C7C _H	DDAR7 [R/W] W XXXXXXXXXXXXXXXXXXXXXXXXXXXXXXXX				
000C80 _H	DCCR8 [R/W] W 0---000 --00--00 00000000 0-000000				
000C84 _H	DCSR8 [R/W] H 0-----000		DTCR8 [R/W] H 00000000 00000000		
000C88 _H	DSAR8 [R/W] W XXXXXXXXXXXXXXXXXXXXXXXXXXXXXXXX				
000C8C _H	DDAR8 [R/W] W XXXXXXXXXXXXXXXXXXXXXXXXXXXXXXXX				
000C90 _H	DCCR9 [R/W] W 0---000 --00--00 00000000 0-000000				
000C94 _H	DCSR9 [R/W] H 0-----000		DTCR9 [R/W] H 00000000 00000000		
000C98 _H	DSAR9 [R/W] W XXXXXXXXXXXXXXXXXXXXXXXXXXXXXXXX				
000C9C _H	DDAR9 [R/W] W XXXXXXXXXXXXXXXXXXXXXXXXXXXXXXXX				
000CA0 _H	DCCR10 [R/W] W 0---000 --00--00 00000000 0-000000				
000CA4 _H	DCSR10 [R/W] H 0-----000		DTCR10 [R/W] H 00000000 00000000		
000CA8 _H	DSAR10 [R/W] W XXXXXXXXXXXXXXXXXXXXXXXXXXXXXXXX				
000CAC _H	DDAR10 [R/W] W XXXXXXXXXXXXXXXXXXXXXXXXXXXXXXXX				
000CB0 _H	DCCR11 [R/W] W 0---000 --00--00 00000000 0-000000				
000CB4 _H	DCSR11 [R/W] H 0-----000		DTCR11 [R/W] H 00000000 00000000		
000CB8 _H	DSAR11 [R/W] W XXXXXXXXXXXXXXXXXXXXXXXXXXXXXXXX				
000CBC _H	DDAR11 [R/W] W XXXXXXXXXXXXXXXXXXXXXXXXXXXXXXXX				

MB91520 Series

Address	Address offset value / Register name				Block	
	+0	+1	+2	+3		
000CC0 _H	DCCR12 [R/W] W 0----000 --00--00 00000000 0-000000				DMA Controller [S]	
000CC4 _H	DCSR12 [R/W] H 0-----000		DTCR12 [R/W] H 00000000 00000000			
000CC8 _H	DSAR12 [R/W] W XXXXXXXX XXXXXXXX XXXXXXXX XXXXXXXX					
000CCC _H	DDAR12 [R/W] W XXXXXXXX XXXXXXXX XXXXXXXX XXXXXXXX					
000CD0 _H	DCCR13 [R/W] W 0----000 --00--00 00000000 0-000000					
000CD4 _H	DCSR13 [R/W] H 0-----000		DTCR13 [R/W] H 00000000 00000000			
000CD8 _H	DSAR13 [R/W] W XXXXXXXX XXXXXXXX XXXXXXXX XXXXXXXX					
000CDC _H	DDAR13 [R/W] W XXXXXXXX XXXXXXXX XXXXXXXX XXXXXXXX					
000CE0 _H	DCCR14 [R/W] W 0----000 --00--00 00000000 0-000000					
000CE4 _H	DCSR14 [R/W] H 0-----000		DTCR14 [R/W] H 00000000 00000000			
000CE8 _H	DSAR14 [R/W] W XXXXXXXX XXXXXXXX XXXXXXXX XXXXXXXX					
000CEC _H	DDAR14 [R/W] W XXXXXXXX XXXXXXXX XXXXXXXX XXXXXXXX					
000CF0 _H	DCCR15 [R/W] W 0----000 --00--00 00000000 0-000000					
000CF4 _H	DCSR15 [R/W] H 0-----000		DTCR15 [R/W] H 00000000 00000000			
000CF8 _H	DSAR15 [R/W] W XXXXXXXX XXXXXXXX XXXXXXXX XXXXXXXX					
000CFC _H	DDAR15 [R/W] W XXXXXXXX XXXXXXXX XXXXXXXX XXXXXXXX					
000D00 _H to 000DF0 _H	—	—	—	—		Reserved [S]
000DF4 _H	—	—	DNMIR [R/W] B 0-----0	DILVR [R/W] B ---1111		DMA Controller [S]
000DF8 _H	DMACR[R/W] W 0-----0-----0-----					
000DFC _H	—	—	—	—		Reserved [S]
000E00 _H	DDR00 [R/W] B,H,W 00000000	DDR01 [R/W] B,H,W 00000000	DDR02 [R/W] B,H,W 00000000	DDR03 [R/W] B,H,W 00000000	Data Direction Register	
000E04 _H	DDR04 [R/W] B,H,W 00000000	DDR05 [R/W] B,H,W 00000000	DDR06 [R/W] B,H,W 00000000	DDR07 [R/W] B,H,W 00000000		

MB91520 Series

Address	Address offset value / Register name				Block	
	+0	+1	+2	+3		
000E08 _H	DDR08 [R/W] B,H,W 00000000	DDR09 [R/W] B,H,W 00000000	DDR10 [R/W] B,H,W 00000000	DDR11 [R/W] B,H,W 00000000	Data Direction Register	
000E0C _H	DDR12 [R/W] B,H,W 00000000	DDR13 [R/W] B,H,W -0000000	DDR14 [R/W] B,H,W ---000--	DDR15 [R/W] B,H,W --000000		
000E10 _H	—	—	—	—		
000E14 _H	—	—	—	—		
000E18 _H	DDR16 [R/W] B,H,W 00000000	DDR17 [R/W] B,H,W 00000000	DDR18 [R/W] B,H,W 00000000	DDR19 [R/W] B,H,W 00000000	Reserved	
000E1C _H	—	—	—	—		
000E20 _H	PFR00 [R/W] B,H,W 00000000	PFR01 [R/W] B,H,W 00000000	PFR02 [R/W] B,H,W 00000000	PFR03 [R/W] B,H,W 00000000		Port Function Register
000E24 _H	PFR04 [R/W] B,H,W 00000000	PFR05 [R/W] B,H,W 00000000	PFR06 [R/W] B,H,W 00000000	PFR07 [R/W] B,H,W 00000000		
000E28 _H	PFR08 [R/W] B,H,W 00000000	PFR09 [R/W] B,H,W 00000000	PFR10 [R/W] B,H,W 00000000	PFR11 [R/W] B,H,W 00000000		
000E2C _H	PFR12 [R/W] B,H,W 00000000	PFR13 [R/W] B,H,W -0000000	PFR14 [R/W] B,H,W ---000--	PFR15 [R/W] B,H,W --000000		
000E30 _H	—	—	—	—		
000E34 _H	—	—	—	—		
000E38 _H	PFR16 [R/W] B,H,W 00000000	PFR17 [R/W] B,H,W 00000000	PFR18 [R/W] B,H,W 00000000	PFR19 [R/W] B,H,W 00000000	Reserved	
000E3C _H	—	—	—	—		
000E40 _H	PDDR00 [R] B,H,W XXXXXXXXXX	PDDR01 [R] B,H,W XXXXXXXXXX	PDDR02 [R] B,H,W XXXXXXXXXX	PDDR03 [R] B,H,W XXXXXXXXXX	Port Direct Read Register	
000E44 _H	PDDR04 [R] B,H,W XXXXXXXXXX	PDDR05 [R] B,H,W XXXXXXXXXX	PDDR06 [R] B,H,W XXXXXXXXXX	PDDR07 [R] B,H,W XXXXXXXXXX		
000E48 _H	PDDR08 [R] B,H,W XXXXXXXXXX	PDDR09 [R] B,H,W XXXXXXXXXX	PDDR10 [R] B,H,W XXXXXXXXXX	PDDR11 [R] B,H,W XXXXXXXXXX		
000E4C _H	PDDR12 [R] B,H,W XXXXXXXXXX	PDDR13 [R] B,H,W -XXXXXXXX	PDDR14 [R] B,H,W ---XXX--	PDDR15 [R] B,H,W --XXXXXX		
000E50 _H	—	—	—	—		
000E54 _H	—	—	—	—		
000E58 _H	PDDR16 [R] B,H,W XXXXXXXXXX	PDDR17 [R] B,H,W XXXXXXXXXX	PDDR18 [R] B,H,W XXXXXXXXXX	PDDR19 [R] B,H,W XXXXXXXXXX	Reserved	
000E5C _H	—	—	—	—		
000E60 _H	EPFR00 [R/W] B,H,W 00000000	EPFR01 [R/W] B,H,W -0-0-000	EPFR02 [R/W] B,H,W ---0000	EPFR03 [R/W] B,H,W --000-0	Extended Port Function Register	
000E64 _H	EPFR04 [R/W] B,H,W ---00-0	EPFR05 [R/W] B,H,W ---0000	EPFR06 [R/W] B,H,W ---000-	EPFR07 [R/W] B,H,W --00000		

MB91520 Series

Address	Address offset value / Register name				Block
	+0	+1	+2	+3	
000E68 _H	EPFR08 [R/W] B,H,W ---00000	EPFR09 [R/W] B,H,W ----00-	EPFR10 [R/W] B,H,W ---0000	EPFR11 [R/W] B,H,W ----0000	Extended Port Function Register
000E6C _H	EPFR12 [R/W] B,H,W ----0000	EPFR13 [R/W] B,H,W -----00	EPFR14 [R/W] B,H,W -----00	EPFR15 [R/W] B,H,W -----000	
000E70 _H	—	—	—	—	
000E74 _H	—	—	—	—	
000E78 _H	—	—	EPFR26 [R/W] B,H,W 00000000	EPFR27 [R/W] B,H,W ---0----	
000E7C _H	EPFR28 [R/W] B,H,W --000-0-	EPFR29 [R/W] B,H,W 00000000	—	—	
000E80 _H	—	EPFR33 [R/W] B,H,W ----00-	EPFR34 [R/W] B,H,W ----00-	EPFR35 [R/W] B,H,W ---00000	
000E84 _H	EPFR36 [R/W] B,H,W ----000-	—	—	—	
000E88 _H	—	—	EPFR42 [R/W] B,H,W -----00	EPFR43 [R/W] B,H,W 0--0000-	
000E8C _H	EPFR44 [R/W] B,H,W -00---0-	EPFR45 [R/W] B,H,W -0000000	—	—	
000E90 _H	—	—	—	—	
000E94 _H	—	—	—	—	
000E98 _H	EPFR56 [R/W] B,H,W -----0-0	EPFR57 [R/W] B,H,W -----00-0	EPFR58 [R/W] B,H,W ---00-0	EPFR59 [R/W] B,H,W ---00-0	
000E9C _H	EPFR60 [R/W] B,H,W ----00-0	EPFR61 [R/W] B,H,W ----00-	EPFR62 [R/W] B,H,W -----00-	EPFR63 [R/W] B,H,W --0000-	
000EA0 _H to 000EBC _H	—	—	—	—	
000EC0 _H	PPER00 [R/W] B,H,W 00000000	PPER01 [R/W] B,H,W 00000000	PPER02 [R/W] B,H,W 00000000	PPER03 [R/W] B,H,W 00000000	Port Pull-up/down Enable Register
000EC4 _H	PPER04 [R/W] B,H,W 00000000	PPER05 [R/W] B,H,W 00000000	PPER06 [R/W] B,H,W 00000000	PPER07 [R/W] B,H,W 00000000	
000EC8 _H	PPER08 [R/W] B,H,W 00000000	PPER09 [R/W] B,H,W 00000000	PPER10 [R/W] B,H,W 00000000	PPER11 [R/W] B,H,W 00000000	
000ECC _H	PPER12 [R/W] B,H,W 00000000	PPER13 [R/W] B,H,W -0000000	PPER14 [R/W] B,H,W ---000--	PPER15 [R/W] B,H,W --000000	
000ED0 _H	—	—	—	—	
000ED4 _H	—	—	—	—	
000ED8 _H	PPER16 [R/W] B,H,W 00000000	PPER17 [R/W] B,H,W 00000000	PPER18 [R/W] B,H,W 00000000	PPER19 [R/W] B,H,W 00000000	

MB91520 Series

Address	Address offset value / Register name				Block
	+0	+1	+2	+3	
000EDC _H to 000F3C _H	—	—	—	—	Reserved
000F40 _H	PORTEN [R/W] B,H,W -----0	—	—	—	Port Enable Register
000F44 _H	KEYCDR [R/W] H 00000000 00000000			—	KeyCodeRegister
000F48 _H to 000F64 _H	—	—	—	—	Reserved
000F68 _H	MSCY6 [R] H,W XXXXXXXX XXXXXXXX XXXXXXXX XXXXXXXX				Input Capture 6,7 Cycle measurement data register 67
000F6C _H	MSCY7 [R] H,W XXXXXXXX XXXXXXXX XXXXXXXX XXXXXXXX				
000F70 _H	RCRH0 [W] H,W XXXXXXXX	RCRL0 [W] B,H,W XXXXXXXX	UDCRH0 [R] H,W 00000000	UDCRL0 [R] B,H,W 00000000	Up/Down Counter 0
000F74 _H	CCR0 [R/W] B,H 00000000 -0001000		—	CSR0 [R/W] B 00000000	
000F78 _H to 000F7C _H	—	—	—	—	Reserved
000F80 _H	RCRH1 [W] H,W XXXXXXXX	RCRL1 [W] B,H,W XXXXXXXX	UDCRH1 [R] H,W 00000000	UDCRL1 [R] B,H,W 00000000	Up/Down Counter 1
000F84 _H	CCR1 [R/W] B,H 00000000 -0001000		—	CSR1 [R/W] B 00000000	
000F88 _H	—	—	MSCH45 [R] B,H,W 00000000	MSCL45 [R/W] B,H,W -----00	Input Capture 4,5 32-bit ICU Cycle and pulse width measurement control 45
000F8C _H	—	—	MSCH67 [R] B,H,W 00000000	MSCL67 [R/W] B,H,W -----00	Input Capture 6,7 32-bit ICU Cycle and pulse width measurement control 67
000F90 _H	OCCP10 [R/W] W 00000000 00000000 00000000 00000000				Output Compare 10,11 32-bit OCU
000F94 _H	OCCP11 [R/W] W 00000000 00000000 00000000 00000000				
000F98 _H	—	—	OCSH1011 [R/W] B,H,W ---0--00	OCSL1011 [R/W] B,H,W 0000--00	
000F9C _H	—	—	—	OCLS1011 [R/W] B,H,W ----0000	OCU1011 Output level control register

MB91520 Series

Address	Address offset value / Register name				Block
	+0	+1	+2	+3	
000FA0 _H	CPCLR5 [R/W] W 11111111 11111111 11111111 11111111				Free-run Timer 5 32-bit FRT
000FA4 _H	TCDT5 [R/W] W 00000000 00000000 00000000 00000000				
000FA8 _H	TCCSH5 [R/W] B,H,W 0----00	TCCSL5 [R/W] B,H,W -1-00000	—	—	
000FAC _H to 000FCC _H	—	—	—	—	Reserved
000FD0 _H	IPCP4 [R] W XXXXXXXX XXXXXXXX XXXXXXXX XXXXXXXX				Input Capture 4,5 32-bit ICU
000FD4 _H	IPCP5 [R] W XXXXXXXX XXXXXXXX XXXXXXXX XXXXXXXX				
000FD8 _H	—	—	LSYNS1 [R/W] B,H,W 00000000	ICS45 [R/W] B,H,W 00000000	
000FDC _H	IPCP6 [R] W XXXXXXXX XXXXXXXX XXXXXXXX XXXXXXXX				Input Capture 6,7 32-bit ICU
000FE0 _H	IPCP7 [R] W XXXXXXXX XXXXXXXX XXXXXXXX XXXXXXXX				
000FE4 _H	—	—	—	ICS67 [R/W] B,H,W 00000000	
000FE8 _H	IPCP8 [R] W XXXXXXXX XXXXXXXX XXXXXXXX XXXXXXXX				Input Capture 8,9 32-bit ICU
000FEC _H	IPCP9 [R] W XXXXXXXX XXXXXXXX XXXXXXXX XXXXXXXX				
000FF0 _H	—	—	—	ICS89 [R/W] B,H,W 00000000	
000FF4 _H	MSCY8 [R] H,W XXXXXXXX XXXXXXXX XXXXXXXX XXXXXXXX				Input Capture 8,9 32-bit ICU Cycle measurement data register 89
000FF8 _H	MSCY9 [R] H,W XXXXXXXX XXXXXXXX XXXXXXXX XXXXXXXX				
000FFC _H	—	—	MSCH89 [R] B,H,W 00000000	MSCL89 [R/W] B,H,W -----00	Cycle and pulse width measurement control 89
001000 _H	SACR [R/W] B,H,W -----0	PICD [R/W] B,H,W ----0011	—	—	Clock Control
001004 _H to 00112C _H	—	—	—	—	Reserved
001130 _H	—	—	—	CRCCR [R/W] B,H,W -0000000	CRC calculation unit
001134 _H	CRCINIT [R/W] B,H,W 11111111 11111111 11111111 11111111				
001138 _H	CRCIN [R/W] B,H,W 00000000 00000000 00000000 00000000				
00113C _H	CRCR [R] B,H,W 11111111 11111111 11111111 11111111				

MB91520 Series

Address	Address offset value / Register name				Block
	+0	+1	+2	+3	
001140 _H to 0011FC _H	—	—	—	—	Reserved
001200 _H	TCGS [R/W] B,H,W -----00	—	—	TCGSE [R/W] B,H,W -----000	16-bit Free-run timer synchronous activation
001204 _H	CPCLRB0/CPCLR0 [W] H,W 11111111 11111111		TCDT0 [R/W] H,W 00000000 00000000		16-bit Free-run Timer 0
001208 _H	TCCS0 [R/W] B,H,W 00000000 01000000 ----0000 -----				
00120C _H	CPCLRB1/CPCLR1 [W] H,W 11111111 11111111		TCDT1 [R/W] H,W 00000000 00000000		16-bit Free-run Timer 1
001210 _H	TCCS1 [R/W] B,H,W 00000000 01000000 ----0000 -----				
001214 _H	CPCLRB2/CPCLR2 [W] H,W 11111111 11111111		TCDT2 [R/W] H,W 00000000 00000000		16-bit Free-run Timer 2
001218 _H	TCCS2 [R/W] B,H,W 00000000 01000000 ----0000 -----				
00121C _H to 001230 _H	—	—	—	—	Reserved
001234 _H	FRS0 [R/W] B,H,W ----- --00--00 --00--00 --00--00				16-bit Free-run timer selection
001238 _H	—	FRS1 [R/W] B,H,W --00--00 --00--00			
00123C _H	FRS2 [R/W] B,H,W --00--00 --00--00 --00--00 --00--00				
001240 _H	FRS3 [R/W] B,H,W --00--00 --00--00 --00--00 --00--00				
001244 _H	FRS4 [R/W] B,H,W --00--00 --00--00 --00--00 --00--00				
001248 _H	—	—	—	—	Reserved
00124C _H	OCCPB0/OCCP0 [R/W] H,W 00000000 00000000		OCCPB1/OCCP1 [R/W] H,W 00000000 00000000		16-bit Output compare 0/1
001250 _H	OCS01 [R/W] B,H,W -110--00 00001100		—	OCMOD01 [R/W] B,H,W -----00	
001254 _H	OCCPB2/OCCP2 [R/W] H,W 00000000 00000000		OCCPB3/OCCP3 [R/W] H,W 00000000 00000000		16-bit Output compare 2/3
001258 _H	OCS23 [R/W] B,H,W -110--00 00001100		—	OCMOD23 [R/W] B,H,W -----00	
00125C _H	OCCPB4/OCCP4 [R/W] H,W 00000000 00000000		OCCPB5/OCCP5 [R/W] H,W 00000000 00000000		16-bit Output compare 4/5
001260 _H	OCS45 [R/W] B,H,W -110--00 00001100		—	OCMOD45 [R/W] B,H,W -----00	

MB91520 Series

Address	Address offset value / Register name				Block
	+0	+1	+2	+3	
001264 _H to 001278 _H	—	—	—	—	Reserved
00127C _H	IPCP0 [R] H,W 00000000 00000000		IPCP1 [R] H,W 00000000 00000000		16-bit Input capture 0/1
001280 _H	ICS01 [R/W] B,H,W -----00 00000000		—	LSYNS [R/W] B,H,W ----0000	
001284 _H	IPCP2 [R] H,W 00000000 00000000		IPCP3 [R] H,W 00000000 00000000		16-bit Input capture 2/3
001288 _H	ICS23 [R/W] B,H,W -----00 00000000		—	—	
00128C _H to 001298 _H	—	—	—	—	Reserved
00129C _H	—	—	—	—	Reserved
0012A0 _H	TMRR0 [R/W] H,W 00000000 00000001		TMRR1 [R/W] H,W 00000000 00000001		Waveform generator 0/1/2
0012A4 _H	TMRR2 [R/W] H,W 00000000 00000001		—	—	
0012A8 _H	DTSCR0 [R/W] B,H,W 00000000	DTSCR1 [R/W] B,H,W 00000000	DTSCR2 [R/W] B,H,W 00000000	—	
0012AC _H	—	DTIR0 [R/W] B,H,W 000000--	—	DTMNS0 [R/W] B,H,W 00--000	
0012B0 _H	—	SIGCR10 [R/W] B,H,W 00000000	—	SIGCR20 [R/W] B,H,W 000000-1	
0012B4 _H	PICS0 [R/W] B,H,W 000000-- -----				
0012B8 _H to 0012CC _H	—	—	—	—	Reserved
0012D0 _H	FRS5 [R/W] B,H,W --00--00 --00--00 --00--00 --00--00				16-bit Free-run timer selection A/D activation compare
0012D4 _H	FRS6 [R/W] B,H,W --00--00 --00--00 --00--00 --00--00				
0012D8 _H	FRS7 [R/W] B,H,W --00--00 --00--00 --00--00 --00--00				
0012DC _H to 0012FC _H	—	—	—	—	Reserved
001300 _H	—				Reserved
001304 _H	ADTSS0[R/W] B,H,W -----0	—	—	—	12-bit A/D converter 1/2 unit
001308 _H	ADTSE0[R/W] B,H,W 00000000 00000000 00000000 00000000				

MB91520 Series

Address	Address offset value / Register name				Block
	+0	+1	+2	+3	
00130 _{C_H}	ADCOMP0/ADCOMPB0[R/W] H,W 00000000 00000000		ADCOMP1/ADCOMPB1[R/W] H,W 00000000 00000000		12-bit A/D converter 1/2 unit
001310 _H	ADCOMP2/ADCOMPB2[R/W] H,W 00000000 00000000		ADCOMP3/ADCOMPB3[R/W] H,W 00000000 00000000		
001314 _H	ADCOMP4/ADCOMPB4[R/W] H,W 00000000 00000000		ADCOMP5/ADCOMPB5[R/W] H,W 00000000 00000000		
001318 _H	ADCOMP6/ADCOMPB6[R/W] H,W 00000000 00000000		ADCOMP7/ADCOMPB7[R/W] H,W 00000000 00000000		
00131C _H	ADCOMP8/ADCOMPB8[R/W] H,W 00000000 00000000		ADCOMP9/ADCOMPB9[R/W] H,W 00000000 00000000		
001320 _H	ADCOMP10/ADCOMPB10[R/W] H,W 00000000 00000000		ADCOMP11/ADCOMPB11[R/W] H,W 00000000 00000000		
001324 _H	ADCOMP12/ADCOMPB12[R/W] H,W 00000000 00000000		ADCOMP13/ADCOMPB13[R/W] H,W 00000000 00000000		
001328 _H	ADCOMP14/ADCOMPB14[R/W] H,W 00000000 00000000		ADCOMP15/ADCOMPB15[R/W] H,W 00000000 00000000		
00132C _H	ADCOMP16/ADCOMPB16[R/W] H,W 00000000 00000000		ADCOMP17/ADCOMPB17[R/W] H,W 00000000 00000000		
001330 _H	ADCOMP18/ADCOMPB18[R/W] H,W 00000000 00000000		ADCOMP19/ADCOMPB19[R/W] H,W 00000000 00000000		
001334 _H	ADCOMP20/ADCOMPB20[R/W] H,W 00000000 00000000		ADCOMP21/ADCOMPB21[R/W] H,W 00000000 00000000		
001338 _H	ADCOMP22/ADCOMPB22[R/W] H,W 00000000 00000000		ADCOMP23/ADCOMPB23[R/W] H,W 00000000 00000000		
00133C _H	ADCOMP24/ADCOMPB24[R/W] H,W 00000000 00000000		ADCOMP25/ADCOMPB25[R/W] H,W 00000000 00000000		
001340 _H	ADCOMP26/ADCOMPB26[R/W] H,W 00000000 00000000		ADCOMP27/ADCOMPB27[R/W] H,W 00000000 00000000		
001344 _H	ADCOMP28/ADCOMPB28[R/W] H,W 00000000 00000000		ADCOMP29/ADCOMPB29[R/W] H,W 00000000 00000000		
001348 _H	ADCOMP30/ADCOMPB30[R/W] H,W 00000000 00000000		ADCOMP31/ADCOMPB31[R/W] H,W 00000000 00000000		
00134C _H	ADTCS0[R/W] B,H,W 00000000 0010----		ADTCS1[R/W] B,H,W 00000000 0010----		
001350 _H	ADTCS2[R/W] B,H,W 00000000 0010----		ADTCS3[R/W] B,H,W 00000000 0010----		
001354 _H	ADTCS4[R/W] B,H,W 00000000 0010----		ADTCS5[R/W] B,H,W 00000000 0010----		
001358 _H	ADTCS6[R/W] B,H,W 00000000 0010----		ADTCS7[R/W] B,H,W 00000000 0010----		
00135C _H	ADTCS8[R/W] B,H,W 00000000 0010----		ADTCS9[R/W] B,H,W 00000000 0010----		
001360 _H	ADTCS10[R/W] B,H,W 00000000 0010----		ADTCS11[R/W] B,H,W 00000000 0010----		

MB91520 Series

Address	Address offset value / Register name				Block
	+0	+1	+2	+3	
001364 _H	ADTCS12[R/W] B,H,W 00000000 0010----		ADTCS13[R/W] B,H,W 00000000 0010----		12-bit A/D converter 1/2 unit
001368 _H	ADTCS14[R/W] B,H,W 00000000 0010----		ADTCS15[R/W] B,H,W 00000000 0010----		
00136C _H	ADTCS16[R/W] B,H,W 00000000 0010----		ADTCS17[R/W] B,H,W 00000000 0010----		
001370 _H	ADTCS18[R/W] B,H,W 00000000 0010----		ADTCS19[R/W] B,H,W 00000000 0010----		
001374 _H	ADTCS20[R/W] B,H,W 00000000 0010----		ADTCS21[R/W] B,H,W 00000000 0010----		
001378 _H	ADTCS22[R/W] B,H,W 00000000 0010----		ADTCS23[R/W] B,H,W 00000000 0010----		
00137C _H	ADTCS24[R/W] B,H,W 00000000 0010----		ADTCS25[R/W] B,H,W 00000000 0010----		
001380 _H	ADTCS26[R/W] B,H,W 00000000 0010----		ADTCS27[R/W] B,H,W 00000000 0010----		
001384 _H	ADTCS28[R/W] B,H,W 00000000 0010----		ADTCS29[R/W] B,H,W 00000000 0010----		
001388 _H	ADTCS30[R/W] B,H,W 00000000 0010----		ADTCS31[R/W] B,H,W 00000000 0010----		
00138C _H	ADTCD0[R] B,H,W 10--0000 00000000		ADTCD1[R] B,H,W 10--0000 00000000		
001390 _H	ADTCD2[R] B,H,W 10--0000 00000000		ADTCD3[R] B,H,W 10--0000 00000000		
001394 _H	ADTCD4[R] B,H,W 10--0000 00000000		ADTCD5[R] B,H,W 10--0000 00000000		
001398 _H	ADTCD6[R] B,H,W 10--0000 00000000		ADTCD7[R] B,H,W 10--0000 00000000		
00139C _H	ADTCD8[R] B,H,W 10--0000 00000000		ADTCD9[R] B,H,W 10--0000 00000000		
0013A0 _H	ADTCD10[R] B,H,W 10--0000 00000000		ADTCD11[R] B,H,W 10--0000 00000000		
0013A4 _H	ADTCD12[R] B,H,W 10--0000 00000000		ADTCD13[R] B,H,W 10--0000 00000000		
0013A8 _H	ADTCD14[R] B,H,W 10--0000 00000000		ADTCD15[R] B,H,W 10--0000 00000000		
0013AC _H	ADTCD16[R] B,H,W 10--0000 00000000		ADTCD17[R] B,H,W 10--0000 00000000		
0013B0 _H	ADTCD18[R] B,H,W 10--0000 00000000		ADTCD19[R] B,H,W 10--0000 00000000		
0013B4 _H	ADTCD20[R] B,H,W 10--0000 00000000		ADTCD21[R] B,H,W 10--0000 00000000		
0013B8 _H	ADTCD22[R] B,H,W 10--0000 00000000		ADTCD23[R] B,H,W 10--0000 00000000		
0013BC _H	ADTCD24[R] B,H,W 10--0000 00000000		ADTCD25[R] B,H,W 10--0000 00000000		

MB91520 Series

Address	Address offset value / Register name				Block
	+0	+1	+2	+3	
0013C0 _H	ADTCD26[R] B,H,W 10--0000 00000000		ADTCD27[R] B,H,W 10--0000 00000000		12-bit A/D converter 1/2 unit
0013C4 _H	ADTCD28[R] B,H,W 10--0000 00000000		ADTCD29[R] B,H,W 10--0000 00000000		
0013C8 _H	ADTCD30[R] B,H,W 10--0000 00000000		ADTCD31[R] B,H,W 10--0000 00000000		
0013CC _H	ADTECS0[R/W] B,H,W -----0 ---00000		ADTECS1[R/W] B,H,W -----0 ---00000		
0013D0 _H	ADTECS2[R/W] B,H,W -----0 ---00000		ADTECS3[R/W] B,H,W -----0 ---00000		
0013D4 _H	ADTECS4[R/W] B,H,W -----0 ---00000		ADTECS5[R/W] B,H,W -----0 ---00000		
0013D8 _H	ADTECS6[R/W] B,H,W -----0 ---00000		ADTECS7[R/W] B,H,W -----0 ---00000		
0013DC _H	ADTECS8[R/W] B,H,W -----0 ---00000		ADTECS9[R/W] B,H,W -----0 ---00000		
0013E0 _H	ADTECS10[R/W] B,H,W -----0 ---00000		ADTECS11[R/W] B,H,W -----0 ---00000		
0013E4 _H	ADTECS12[R/W] B,H,W -----0 ---00000		ADTECS13[R/W] B,H,W -----0 ---00000		
0013E8 _H	ADTECS14[R/W] B,H,W -----0 ---00000		ADTECS15[R/W] B,H,W -----0 ---00000		
0013EC _H	ADTECS16[R/W] B,H,W -----0 ---00000		ADTECS17[R/W] B,H,W -----0 ---00000		
0013F0 _H	ADTECS18[R/W] B,H,W -----0 ---00000		ADTECS19[R/W] B,H,W -----0 ---00000		
0013F4 _H	ADTECS20[R/W] B,H,W -----0 ---00000		ADTECS21[R/W] B,H,W -----0 ---00000		
0013F8 _H	ADTECS22[R/W] B,H,W -----0 ---00000		ADTECS23[R/W] B,H,W -----0 ---00000		
0013FC _H	ADTECS24[R/W] B,H,W -----0 ---00000		ADTECS25[R/W] B,H,W -----0 ---00000		
001400 _H	ADTECS26[R/W] B,H,W -----0 ---00000		ADTECS27[R/W] B,H,W -----0 ---00000		
001404 _H	ADTECS28[R/W] B,H,W -----0 ---00000		ADTECS29[R/W] B,H,W -----0 ---00000		
001408 _H	ADTECS30[R/W] B,H,W -----0 ---00000		ADTECS31[R/W] B,H,W -----0 ---00000		
00140C _H	ADRCUT0[R/W] B,H,W ----0000 00000000		ADRCLT0[R/W] B,H,W ----0000 00000000		
001410 _H	ADRCUT1[R/W] B,H,W ----0000 00000000		ADRCLT1[R/W] B,H,W ----0000 00000000		
001414 _H	ADRCUT2[R/W] B,H,W ----0000 00000000		ADRCLT2[R/W] B,H,W ----0000 00000000		
001418 _H	ADRCUT3[R/W] B,H,W ----0000 00000000		ADRCLT3[R/W] B,H,W ----0000 00000000		

MB91520 Series

Address	Address offset value / Register name				Block
	+0	+1	+2	+3	
00141C _H	ADRCCS0[R/W] B,H,W 00000000	ADRCCS1[R/W] B,H,W 00000000	ADRCCS2[R/W] B,H,W 00000000	ADRCCS3[R/W] B,H,W 00000000	12-bit A/D converter 1/2 unit
001420 _H	ADRCCS4[R/W] B,H,W 00000000	ADRCCS5[R/W] B,H,W 00000000	ADRCCS6[R/W] B,H,W 00000000	ADRCCS7[R/W] B,H,W 00000000	
001424 _H	ADRCCS8[R/W] B,H,W 00000000	ADRCCS9[R/W] B,H,W 00000000	ADRCCS10[R/W] B,H,W 00000000	ADRCCS11[R/W] B,H,W 00000000	
001428 _H	ADRCCS12[R/W] B,H,W 00000000	ADRCCS13[R/W] B,H,W 00000000	ADRCCS14[R/W] B,H,W 00000000	ADRCCS15[R/W] B,H,W 00000000	
00142C _H	ADRCCS16[R/W] B,H,W 00000000	ADRCCS17[R/W] B,H,W 00000000	ADRCCS18[R/W] B,H,W 00000000	ADRCCS19[R/W] B,H,W 00000000	
001430 _H	ADRCCS20[R/W] B,H,W 00000000	ADRCCS21[R/W] B,H,W 00000000	ADRCCS22[R/W] B,H,W 00000000	ADRCCS23[R/W] B,H,W 00000000	
001434 _H	ADRCCS24[R/W] B,H,W 00000000	ADRCCS25[R/W] B,H,W 00000000	ADRCCS26[R/W] B,H,W 00000000	ADRCCS27[R/W] B,H,W 00000000	
001438 _H	ADRCCS28[R/W] B,H,W 00000000	ADRCCS29[R/W] B,H,W 00000000	ADRCCS30[R/W] B,H,W 00000000	ADRCCS31[R/W] B,H,W 00000000	
00143C _H	ADRCOT0[R] B,H,W 00000000 00000000 00000000 00000000				
001440 _H	ADRCIF0[R,W] B,H,W 00000000 00000000 00000000 00000000				
001444 _H	ADSCANS0[R/W] B,H,W 000-----	—	—	—	
001448 _H	ADNCS0[R/W] B,H,W 0-000-00	ADNCS1[R/W] B,H,W 0-000-00	ADNCS2[R/W] B,H,W 0-000-00	ADNCS3[R/W] B,H,W 0-000-00	
00144C _H	ADNCS4[R/W] B,H,W 0-000-00	ADNCS5[R/W] B,H,W 0-000-00	ADNCS6[R/W] B,H,W 0-000-00	ADNCS7[R/W] B,H,W 0-000-00	
001450 _H	ADNCS8[R/W] B,H,W 0-000-00	ADNCS9[R/W] B,H,W 0-000-00	ADNCS10[R/W] B,H,W 0-000-00	ADNCS11[R/W] B,H,W 0-000-00	
001454 _H	ADNCS12[R/W] B,H,W 0-000-00	ADNCS13[R/W] B,H,W 0-000-00	ADNCS14[R/W] B,H,W 0-000-00	ADNCS15[R/W] B,H,W 0-000-00	
001458 _H	ADPRTF0[R] B,H,W 00000000 00000000 00000000 00000000				
00145C _H	ADEOCF0[R] B,H,W 11111111 11111111 11111111 11111111				
001460 _H	ADCS0[R] B,H,W 0-----		ADCH0[R] B,H,W ---00000	ADMD0[R/W] B,H,W 0---0000	
001464 _H	ADSTPCS0[R/W] B,H,W 00000000	ADSTPCS1[R/W] B,H,W 00000000	ADSTPCS2[R/W] B,H,W 00000000	ADSTPCS3[R/W] B,H,W 00000000	

MB91520 Series

Address	Address offset value / Register name				Block
	+0	+1	+2	+3	
001468 _H	ADSTPCS4[R/W] B,H,W 00000000	ADSTPCS5[R/W] B,H,W 00000000	ADSTPCS6[R/W] B,H,W 00000000	ADSTPCS7[R/W] B,H,W 00000000	12-bit A/D converter 1/2 unit
00146C _H	—				
001470 _H	ADTSS1[R/W] B,H,W -----0	—	—	—	12-bit A/D converter 2/2 unit
001474 _H	ADTSE1[R/W] B,H,W ----- 00000000 00000000				
001478 _H	ADCOMP32/ADCOMPB32[R/W] H,W 00000000 00000000		ADCOMP33/ADCOMPB33[R/W] H,W 00000000 00000000		
00147C _H	ADCOMP34/ADCOMPB34[R/W] H,W 00000000 00000000		ADCOMP35/ADCOMPB35[R/W] H,W 00000000 00000000		
001480 _H	ADCOMP36/ADCOMPB36[R/W] H,W 00000000 00000000		ADCOMP37/ADCOMPB37[R/W] H,W 00000000 00000000		
001484 _H	ADCOMP38/ADCOMPB38[R/W] H,W 00000000 00000000		ADCOMP39/ADCOMPB39[R/W] H,W 00000000 00000000		
001488 _H	ADCOMP40/ADCOMPB40[R/W] H,W 00000000 00000000		ADCOMP41/ADCOMPB41[R/W] H,W 00000000 00000000		
00148C _H	ADCOMP42/ADCOMPB42[R/W] H,W 00000000 00000000		ADCOMP43/ADCOMPB43[R/W] H,W 00000000 00000000		
001490 _H	ADCOMP44/ADCOMPB44[R/W] H,W 00000000 00000000		ADCOMP45/ADCOMPB45[R/W] H,W 00000000 00000000		
001494 _H	ADCOMP46/ADCOMPB46[R/W] H,W 00000000 00000000		ADCOMP47/ADCOMPB47[R/W] H,W 00000000 00000000		
001498 _H to 0014B4 _H	—	—	—	—	Reserved
0014B8 _H	ADTCS32[R/W] B,H,W 00000000 0010----		ADTCS33[R/W] B,H,W 00000000 0010----		12-bit A/D converter 2/2 unit
0014BC _H	ADTCS34[R/W] B,H,W 00000000 0010----		ADTCS35[R/W] B,H,W 00000000 0010----		
0014C0 _H	ADTCS36[R/W] B,H,W 00000000 0010----		ADTCS37[R/W] B,H,W 00000000 0010----		
0014C4 _H	ADTCS38[R/W] B,H,W 00000000 0010----		ADTCS39[R/W] B,H,W 00000000 0010----		
0014C8 _H	ADTCS40[R/W] B,H,W 00000000 0010----		ADTCS41[R/W] B,H,W 00000000 0010----		
0014CC _H	ADTCS42[R/W] B,H,W 00000000 0010----		ADTCS43[R/W] B,H,W 00000000 0010----		
0014D0 _H	ADTCS44[R/W] B,H,W 00000000 0010----		ADTCS45[R/W] B,H,W 00000000 0010----		
0014D4 _H	ADTCS46[R/W] B,H,W 00000000 0010----		ADTCS47[R/W] B,H,W 00000000 0010----		

MB91520 Series

Address	Address offset value / Register name				Block
	+0	+1	+2	+3	
0014D8 _H to 0014F4 _H	—	—	—	—	Reserved
0014F8 _H	ADTCD32[R] B,H,W 10--0000 00000000		ADTCD33[R] B,H,W 10--0000 00000000		12-bit A/D converter 2/2 unit
0014FC _H	ADTCD34[R] B,H,W 10--0000 00000000		ADTCD35[R] B,H,W 10--0000 00000000		
001500 _H	ADTCD36[R] B,H,W 10--0000 00000000		ADTCD37[R] B,H,W 10--0000 00000000		
001504 _H	ADTCD38[R] B,H,W 10--0000 00000000		ADTCD39[R] B,H,W 10--0000 00000000		
001508 _H	ADTCD40[R] B,H,W 10--0000 00000000		ADTCD41[R] B,H,W 10--0000 00000000		
00150C _H	ADTCD42[R] B,H,W 10--0000 00000000		ADTCD43[R] B,H,W 10--0000 00000000		
001510 _H	ADTCD44[R] B,H,W 10--0000 00000000		ADTCD45[R] B,H,W 10--0000 00000000		
001514 _H	ADTCD46[R] B,H,W 10--0000 00000000		ADTCD47[R] B,H,W 10--0000 00000000		
001518 _H to 001534 _H	—	—	—	—	Reserved
001538 _H	ADTECS32[R/W] B,H,W -----0 ----0000		ADTECS33[R/W] B,H,W -----0 ----0000		12-bit A/D converter 2/2 unit
00153C _H	ADTECS34[R/W] B,H,W -----0 ----0000		ADTECS35[R/W] B,H,W -----0 ----0000		
001540 _H	ADTECS36[R/W] B,H,W -----0 ----0000		ADTECS37[R/W] B,H,W -----0 ----0000		
001544 _H	ADTECS38[R/W] B,H,W -----0 ----0000		ADTECS39[R/W] B,H,W -----0 ----0000		
001548 _H	ADTECS40[R/W] B,H,W -----0 ----0000		ADTECS41[R/W] B,H,W -----0 ----0000		
00154C _H	ADTECS42[R/W] B,H,W -----0 ----0000		ADTECS43[R/W] B,H,W -----0 ----0000		
001550 _H	ADTECS44[R/W] B,H,W -----0 ----0000		ADTECS45[R/W] B,H,W -----0 ----0000		
001554 _H	ADTECS46[R/W] B,H,W -----0 ----0000		ADTECS47[R/W] B,H,W -----0 ----0000		
001558 _H to 001574 _H	—	—	—	—	Reserved
001578 _H	ADRCUT4[R/W] B,H,W ---0000 00000000		ADRCLT4[R/W] B,H,W ---0000 00000000		12-bit A/D converter 2/2 unit
00157C _H	ADRCUT5[R/W] B,H,W ---0000 00000000		ADRCLT5[R/W] B,H,W ---0000 00000000		
001580 _H	ADRCUT6[R/W] B,H,W ---0000 00000000		ADRCLT6[R/W] B,H,W ---0000 00000000		

MB91520 Series

Address	Address offset value / Register name				Block
	+0	+1	+2	+3	
001584 _H	ADRCUT7[R/W] B,H,W ----0000 00000000		ADRCLT7[R/W] B,H,W ----0000 00000000		12-bit A/D converter 2/2 unit
001588 _H	ADRCCS32[R/W] B,H,W 00000000	ADRCCS33[R/W] B,H,W 00000000	ADRCCS34[R/W] B,H,W 00000000	ADRCCS35[R/W] B,H,W 00000000	
00158C _H	ADRCCS36[R/W] B,H,W 00000000	ADRCCS37[R/W] B,H,W 00000000	ADRCCS38[R/W] B,H,W 00000000	ADRCCS39[R/W] B,H,W 00000000	
001590 _H	ADRCCS40[R/W] B,H,W 00000000	ADRCCS41[R/W] B,H,W 00000000	ADRCCS42[R/W] B,H,W 00000000	ADRCCS43[R/W] B,H,W 00000000	
001594 _H	ADRCCS44[R/W] B,H,W 00000000	ADRCCS45[R/W] B,H,W 00000000	ADRCCS46[R/W] B,H,W 00000000	ADRCCS47[R/W] B,H,W 00000000	
001598 _H to 0015A4 _H	—	—	—	—	
0015A8 _H	ADRCOT1 [R] B,H,W ----- 00000000 00000000				12-bit A/D converter 2/2 unit
0015AC _H	ADRCIF1 [R,W] B,H,W ----- 00000000 00000000				
0015B0 _H	ADSCANS1 [R/W] B,H,W 000-----	—	—	—	
0015B4 _H	ADNCS16 [R/W] B,H,W 0-000-00	ADNCS17 [R/W] B,H,W 0-000-00	ADNCS18 [R/W] B,H,W 0-000-00	ADNCS19 [R/W] B,H,W 0-000-00	
0015B8 _H	ADNCS20 [R/W] B,H,W 0-000-00	ADNCS21 [R/W] B,H,W 0-000-00	ADNCS22 [R/W] B,H,W 0-000-00	ADNCS23 [R/W] B,H,W 0-000-00	
0015BC _H	—	—	—	—	
0015C0 _H	—	—	—	—	
0015C4 _H	ADPRTF1 [R] B,H,W ----- 00000000 00000000				
0015C8 _H	ADEOCF1 [R] B,H,W ----- 11111111 11111111				
0015CC _H	ADCS1 [R] B,H,W 0-----		ADCH1 [R] B,H,W ---00000	ADMD1 [R/W] B,H,W 0---0000	
0015D0 _H	ADSTPCS8 [R/W] B,H,W 00000000	ADSTPCS9 [R/W] B,H,W 00000000	ADSTPCS10 [R/W] B,H,W 00000000	ADSTPCS11 [R/W] B,H,W 00000000	

MB91520 Series

Address	Address offset value / Register name				Block
	+0	+1	+2	+3	
0015D4 _H to 00174C _H	—	—	—	—	Reserved
001750 _H	SCR0/(IBCR0)[R/W] B,H,W 0--00000	SMR0[R/W] B,H,W 000-00-0	SSR0[R/W] B,H,W 0-000011	ESCR0/(IBSR0)[R/W] B,H,W 00000000	Multi-UART0 *1: Byte access is possible only for access to lower 8 bits. *2: Reserved because I ² C mode is not set immediately after reset. *3: Reserved because CSIO mode is not set immediately after reset. *4: Reserved because LIN2.1 mode is not set immediately after reset.
001754 _H	— /(RDR10/(TDR10))[R/W] B,H,W ----- ^{*3}		RDR00/(TDR00)[R/W] B,H,W -----0 00000000 ^{*1}		
001758 _H	SACSR0[R/W] B,H,W 0---000 00000000		STMR0[R] B,H,W 00000000 00000000		
00175C _H	STMCR0[R/W] B,H,W 00000000 00000000		— /(SCSCR0/SFUR0)[R/W] B,H,W ----- ^{*3 *4}		
001760 _H	— /(SCSTR30)/ (LAMSR0) [R/W] B,H,W ----- ^{*3}	— /(SCSTR20)/ (LAMCR0) [R/W] B,H,W ----- ^{*3}	— /(SCSTR10) /(SFLR10) [R/W] B,H,W ----- ^{*3}	— /(SCSTR00)/ (SFLR00) [R/W] B,H,W ----- ^{*3}	
001764 _H	—	— /(SCSFR20) [R/W] B,H,W ----- ^{*3}	— /(SCSFR10) [R/W] B,H,W ----- ^{*3}	— /(SCSFR00) [R/W] B,H,W ----- ^{*3}	
001768 _H	—/(TBYTE30)/ (LAMESR0) [R/W] B,H,W ----- ^{*3}	—/(TBYTE20) /(LAMERT0) [R/W] B,H,W ----- ^{*3}	—/(TBYTE10)/ (LAMIER0) [R/W] B,H,W ----- ^{*3}	TBYTE00/(LAMRID0) / (LAMTID0) [R/W] B,H,W 00000000	
00176C _H	BGR0[R/W] H, W 00000000 00000000		— /(ISMK0) [R/W] B,H,W ----- ^{*2}	— /(ISBA0) [R/W] B,H,W ----- ^{*2}	
001770 _H	FCR10[R/W] B,H,W ---00100	FCR00[R/W] B,H,W -0000000	FBYTE0[R/W] B,H,W 00000000 00000000		
001774 _H	FTICR0[R/W] B,H,W 00000000 00000000		—	—	

MB91520 Series

Address	Address offset value / Register name				Block
	+0	+1	+2	+3	
001778 _H	SCR1/(IBCR1) [R/W] B,H,W 0--00000	SMR1[R/W] B,H,W 000-00-0	SSR1[R/W] B,H,W 0-000011	ESCR1/(IBSR1)[R/W] B,H,W 00000000	Multi-UART1 *1: Byte access is possible only for access to lower 8 bits. *2: Reserved because I ² C mode is not set immediately after reset. *3: Reserved because CSIO mode is not set immediately after reset. *4: Reserved because LIN2.1 mode is not set immediately after reset.
00177C _H	—/(RDR11/(TDR11))[R/W] B,H,W ----- *3		RDR01/(TDR01)[R/W] B,H,W -----0 00000000 *1		
001780 _H	SACSR1[R/W] B,H,W 0---000 00000000		STMR1[R] B,H,W 00000000 00000000		
001784 _H	STMC1[R/W] B,H,W 00000000 00000000		—/(SCSCR1/SFUR1)[R/W] B,H,W ----- *3 *4		
001788 _H	—/(SCSTR31)/ (LAMSR1) [R/W] B,H,W ----- *3	—/(SCSTR21)/ (LAMCR1) [R/W] B,H,W ----- *3	—/(SCSTR11)/ (SFLR11) [R/W] B,H,W ----- *3	—/(SCSTR01)/ (SFLR01) [R/W] B,H,W ----- *3	
00178C _H	—	—/(SCSFR21)[R/W] B,H,W ----- *3	—/(SCSFR11) [R/W] B,H,W ----- *3	—/(SCSFR01) [R/W] B,H,W ----- *3	
001790 _H	—/(TBYTE31)/ (LAMESR1) [R/W] B,H,W ----- *3	—/(TBYTE21)/ (LAMERT1) [R/W] B,H,W ----- *3	—/(TBYTE11)/ (LAMIER1) [R/W] B,H,W ----- *3	TBYTE01/(LAMRID1) / (LAMTID1) [R/W] B,H,W 00000000	
001794 _H	BGR1[R/W] H,W 00000000 00000000		—/(ISMK1)[R/W] B,H,W ----- *2	—/(ISBA1)[R/W] B,H,W ----- *2	
001798 _H	FCR11[R/W] B,H,W ---00100	FCR01[R/W] B,H,W -0000000	FBYTE1[R/W] B,H,W 00000000 00000000		
00179C _H	FTICR1[R/W] B,H,W 00000000 00000000		—	—	

MB91520 Series

Address	Address offset value / Register name				Block
	+0	+1	+2	+3	
0017A0 _H	SCR2/(IBCR2)[R/W] B,H,W 0--00000	SMR2[R/W] B,H,W 000-00-0	SSR2[R/W] B,H,W 0-000011	ESCR2/(IBSR2)[R/W] B,H,W 00000000	Multi-UART2 *1: Byte access is possible only for access to lower 8 bits. *2: Reserved because I ² C mode is not set immediately after reset. *3: Reserved because CSIO mode is not set immediately after reset. *4: Reserved because LIN2.1 mode is not set immediately after reset.
0017A4 _H	—/(RDR12/(TDR12))[R/W] B,H,W ----- ^{*3}		RDR02/(TDR02)[R/W] B,H,W -----0 00000000 ^{*1}		
0017A8 _H	SACSR2[R/W] B,H,W 0---000 00000000		STMR2[R] B,H,W 00000000 00000000		
0017AC _H	STMCR2[R/W] B,H,W 00000000 00000000		—/(SCSCR2/SFUR2)[R/W] B,H,W ----- ^{*3} *4		
0017B0 _H	—/(SCSTR32)/ (LAMSR2) [R/W] B,H,W ----- ^{*3}	—/(SCSTR22)/ (LAMCR2) [R/W] B,H,W ----- ^{*3}	—/(SCSTR12)/ (SFLR12) [R/W] B,H,W ----- ^{*3}	—/(SCSTR02)/ (SFLR02) [R/W] B,H,W ----- ^{*3}	
0017B4 _H	—	—/(SCSFR22) [R/W] B,H,W ----- ^{*3}	—/(SCSFR12) [R/W] B,H,W ----- ^{*3}	—/(SCSFR02) [R/W] B,H,W ----- ^{*3}	
0017B8 _H	—/(TBYTE32)/ (LAMESR2) [R/W] B,H,W ----- ^{*3}	—/(TBYTE22)/ (LAMERT2) [R/W] B,H,W ----- ^{*3}	—/(TBYTE12)/ (LAMIER2) [R/W] B,H,W ----- ^{*3}	TBYTE02/(LAMRID2) / (LAMTID2) [R/W] B,H,W 00000000	
0017BC _H	BGR2[R/W] H, W 00000000 00000000		—/(ISMK2)[R/W] B,H,W ----- ^{*2}	—/(ISBA2)[R/W] B,H,W ----- ^{*2}	
0017C0 _H	FCR12[R/W] B,H,W --00100	FCR02[R/W] B,H,W -0000000	FBYTE2[R/W] B,H,W 00000000 00000000		
0017C4 _H	FTICR2[R/W] B,H,W 00000000 00000000		—	—	

MB91520 Series

Address	Address offset value / Register name				Block
	+0	+1	+2	+3	
0017C8 _H	SCR3/(IBCR3) [R/W] B,H,W 0--00000	SMR3[R/W] B,H,W 000-00-0	SSR3[R/W] B,H,W 0-000011	ESCR3/(IBSR3)[R/W] B,H,W 00000000	Multi-UART3 *1: Byte access is possible only for access to lower 8 bits. *2: Reserved because I ² C mode is not set immediately after reset. *3: Reserved because CSIO mode is not set immediately after reset. *4: Reserved because LIN2.1 mode is not set immediately after reset.
0017CC _H	—/(RDR13/(TDR13))[R/W] B,H,W ----- ^{*3}		RDR03/(TDR03)[R/W] B,H,W -----0 00000000 ^{*1}		
0017D0 _H	SACSR3[R/W] B,H,W 0---000 00000000		STMR3[R] B,H,W 00000000 00000000		
0017D4 _H	STMCR3[R/W] B,H,W 00000000 00000000		—/(SCSCR3/SFUR3)[R/W] B,H,W ----- ^{*3 *4}		
0017D8 _H	—/(SCSTR33)/ (LAMSR3) [R/W] B,H,W ----- ^{*3}	—/(SCSTR23)/ (LAMCR3) [R/W] B,H,W ----- ^{*3}	—/(SCSTR13)/ (SFLR13) [R/W] B,H,W ----- ^{*3}	—/(SCSTR03)/ (SFLR03) [R/W] B,H,W ----- ^{*3}	
0017DC _H	—	—/(SCSFR23) [R/W] B,H,W ----- ^{*3}	—/(SCSFR13) [R/W] B,H,W ----- ^{*3}	—/(SCSFR03) [R/W] B,H,W ----- ^{*3}	
0017E0 _H	—/(TBYTE33)/ (LAMESR3) [R/W] B,H,W ----- ^{*3}	—/(TBYTE23)/ (LAMERT3) [R/W] B,H,W ----- ^{*3}	—/(TBYTE13)/ (LAMIER3) [R/W] B,H,W ----- ^{*3}	TBYTE03/(LAMRID3) / (LAMTID3) [R/W] B,H,W 00000000	
0017E4 _H	BGR3[R/W] H, W 00000000 00000000		—/(ISMK3)[R/W] B,H,W ----- ^{*2}	—/(ISBA3)[R/W] B,H,W ----- ^{*2}	
0017E8 _H	FCR13[R/W] B,H,W --00100	FCR03[R/W] B,H,W -0000000	FBYTE3[R/W] B,H,W 00000000 00000000		
0017EC _H	FTICR3[R/W] B,H,W 00000000 00000000		—	—	

MB91520 Series

Address	Address offset value / Register name				Block
	+0	+1	+2	+3	
0017F0 _H	SCR4/(IBCR4) [R/W] B,H,W 0--00000	SMR4[R/W] B,H,W 000-00-0	SSR4[R/W] B,H,W 0-000011	ESCR4/(IBSR4)[R/W] B,H,W 00000000	Multi-UART4 *1: Byte access is possible only for access to lower 8 bits. *2: Reserved because I ² C mode is not set immediately after reset. *3: Reserved because CSIO mode is not set immediately after reset. *4: Reserved because LIN2.1 mode is not set immediately after reset.
0017F4 _H	—/(RDR14/(TDR14))[R/W] B,H,W ----- ^{*3}		RDR04/(TDR04)[R/W] B,H,W -----0 00000000 ^{*1}		
0017F8 _H	SACSR4[R/W] B,H,W 0---000 00000000		STMR4[R] B,H,W 00000000 00000000		
0017FC _H	STMCR4[R/W] B,H,W 00000000 00000000		—/(SCSCR4/SFUR4)[R/W] B,H,W ----- ^{*3} *4		
001800 _H	—/(SCSTR34)/ (LAMSR4) [R/W] B,H,W ----- ^{*3}	—/(SCSTR24)/ (LAMCR4) [R/W] B,H,W ----- ^{*3}	—/(SCSTR14)/ (SFLR14) [R/W] B,H,W ----- ^{*3}	—/(SCSTR04)/ (SFLR04) [R/W] B,H,W ----- ^{*3}	
001804 _H	—	—/(SCSFR24) [R/W] B,H,W ----- ^{*3}	—/(SCSFR14) [R/W] B,H,W ----- ^{*3}	—/(SCSFR04) [R/W] B,H,W ----- ^{*3}	
001808 _H	—/(TBYTE34)/ (LAMESR4) [R/W] B,H,W ----- ^{*3}	—/(TBYTE24)/ (LAMERT4) [R/W] B,H,W ----- ^{*3}	—/(TBYTE14)/ (LAMIER4) [R/W] B,H,W ----- ^{*3}	TBYTE04/(LAMRID4) / (LAMTID4) [R/W] B,H,W 00000000	
00180C _H	BGR4[R/W] H, W 00000000 00000000		—/(ISMK4)[R/W] B,H,W ----- ^{*2}	—/(ISBA4)[R/W] B,H,W ----- ^{*2}	
001810 _H	FCR14[R/W] B,H,W --00100	FCR04[R/W] B,H,W -0000000	FBYTE4[R/W] B,H,W 00000000 00000000		
001814 _H	FTICR4[R/W] B,H,W 00000000 00000000		—	—	

MB91520 Series

Address	Address offset value / Register name				Block
	+0	+1	+2	+3	
001818 _H	SCR5/(IBCR5) [R/W] B,H,W 0--00000	SMR5[R/W] B,H,W 000-00-0	SSR5[R/W] B,H,W 0-000011	ESCR5/(IBSR5)[R/W] B,H,W 00000000	Multi-UART5 *1: Byte access is possible only for access to lower 8 bits. *2: Reserved because I ² C mode is not set immediately after reset. *3: Reserved because CSIO mode is not set immediately after reset. *4: Reserved because LIN2.1 mode is not set immediately after reset.
00181C _H	—/(RDR15/(TDR15))[R/W] B,H,W ----- *3		RDR05/(TDR05)[R/W] B,H,W -----0 00000000 *1		
001820 _H	SACSR5[R/W] B,H,W 0---000 00000000		STMR5[R] B,H,W 00000000 00000000		
001824 _H	STMCR5[R/W] B,H,W 00000000 00000000		—/(SCSCR5/SFUR5)[R/W] B,H,W ----- *3 *4		
001828 _H	—/(SCSTR35)/ (LAMSR5) [R/W] B,H,W ----- *3	—/(SCSTR25)/ (LAMCR5) [R/W] B,H,W ----- *3	—/(SCSTR15)/ (SFLR15) [R/W] B,H,W ----- *3	—/(SCSTR05)/ (SFLR05) [R/W] B,H,W ----- *3	
00182C _H	—	—/(SCSFR25) [R/W] B,H,W ----- *3	—/(SCSFR15) [R/W] B,H,W ----- *3	—/(SCSFR05) [R/W] B,H,W ----- *3	
001830 _H	—/(TBYTE35)/ (LAMESR5) [R/W] B,H,W ----- *3	—/(TBYTE25)/ (LAMERT5) [R/W] B,H,W ----- *3	—/(TBYTE15)/ (LAMIER5) [R/W] B,H,W ----- *3	TBYTE05/(LAMRID5) / (LAMTID5) [R/W] B,H,W 00000000	
001834 _H	BGR5[R/W] H, W 00000000 00000000		—/(ISMK5)[R/W] B,H,W ----- *2	—/(ISBA5)[R/W] B,H,W ----- *2	
001838 _H	FCR15[R/W] B,H,W ---00100	FCR05[R/W] B,H,W -0000000	FBYTE5[R/W] B,H,W 00000000 00000000		
00183C _H	FTICR5[R/W] B,H,W 00000000 00000000		—	—	

MB91520 Series

Address	Address offset value / Register name				Block
	+0	+1	+2	+3	
001840 _H	SCR6/(IBCR6) [R/W] B,H,W 0--00000	SMR6[R/W] B,H,W 000-00-0	SSR6[R/W] B,H,W 0-000011	ESCR6/(IBSR6)[R/W] B,H,W 00000000	Multi-UART6 *1: Byte access is possible only for access to lower 8 bits. *2: Reserved because I ² C mode is not set immediately after reset. *3: Reserved because CSIO mode is not set immediately after reset. *4: Reserved because LIN2.1 mode is not set immediately after reset.
001844 _H	—/(RDR16/(TDR16))[R/W] B,H,W ----- ^{*3}		RDR06/(TDR06)[R/W] B,H,W -----0 00000000 ^{*1}		
001848 _H	SACSR6[R/W] B,H,W 0---000 00000000		STMR6[R] B,H,W 00000000 00000000		
00184C _H	STMCR6[R/W] B,H,W 00000000 00000000		—/(SCSCR6/SFUR6)[R/W] B,H,W ----- ^{*3} *4		
001850 _H	—/(SCSTR36)/ (LAMSR6) [R/W] B,H,W ----- ^{*3}	—/(SCSTR26)/ (LAMCR6) [R/W] B,H,W ----- ^{*3}	—/(SCSTR16)/ (SFLR16) [R/W] B,H,W ----- ^{*3}	—/(SCSTR06)/ (SFLR06) [R/W] B,H,W ----- ^{*3}	
001854 _H	—	—/(SCSFR26) [R/W] B,H,W ----- ^{*3}	—/(SCSFR16) [R/W] B,H,W ----- ^{*3}	—/(SCSFR06) [R/W] B,H,W ----- ^{*3}	
001858 _H	—/(TBYTE36)/ (LAMESR6) [R/W] B,H,W ----- ^{*3}	—/(TBYTE26)/ (LAMERT6) [R/W] B,H,W ----- ^{*3}	—/(TBYTE16)/ (LAMIER6) [R/W] B,H,W ----- ^{*3}	TBYTE06/(LAMRID6) / (LAMTID6) [R/W] B,H,W 00000000	
00185C _H	BGR6[R/W] H, W 00000000 00000000		—/(ISMK6)[R/W] B,H,W ----- ^{*2}	—/(ISBA6)[R/W] B,H,W ----- ^{*2}	
001860 _H	FCR16[R/W] B,H,W --00100	FCR06[R/W] B,H,W -0000000	FBYTE6[R/W] B,H,W 00000000 00000000		
001864 _H	FTICR6[R/W] B,H,W 00000000 00000000		—	—	

MB91520 Series

Address	Address offset value / Register name				Block
	+0	+1	+2	+3	
001868 _H	SCR7/(IBCR7) [R/W] B,H,W 0--00000	SMR7[R/W] B,H,W 000-00-0	SSR7[R/W] B,H,W 0-000011	ESCR7/(IBSR7)[R/W] B,H,W 00000000	Multi-UART7 *1: Byte access is possible only for access to lower 8 bits. *2: Reserved because I ² C mode is not set immediately after reset. *3: Reserved because CSIO mode is not set immediately after reset. *4: Reserved because LIN2.1 mode is not set immediately after reset.
00186C _H	—/(RDR17/(TDR17))[R/W] B,H,W ----- ^{*3}		RDR07/(TDR07)[R/W] B,H,W -----0 00000000 ^{*1}		
001870 _H	SACSR7[R/W] B,H,W 0---000 00000000		STMR7[R] B,H,W 00000000 00000000		
001874 _H	STMCR7[R/W] B,H,W 00000000 00000000		—/(SCSCR7/SFUR7)[R/W] B,H,W ----- ^{*3} *4		
001878 _H	—/(SCSTR37)/ (LAMSR7) [R/W] B,H,W ----- ^{*3}	—/(SCSTR27)/ (LAMCR7) [R/W] B,H,W ----- ^{*3}	—/(SCSTR17)/ (SFLR17) [R/W] B,H,W ----- ^{*3}	—/(SCSTR07)/ (SFLR07) [R/W] B,H,W ----- ^{*3}	
00187C _H	—	—/(SCSFR27) [R/W] B,H,W ----- ^{*3}	—/(SCSFR17) [R/W] B,H,W ----- ^{*3}	—/(SCSFR07) [R/W] B,H,W ----- ^{*3}	
001880 _H	—/(TBYTE37)/ (LAMESR7) [R/W] B,H,W ----- ^{*3}	—/(TBYTE27)/ (LAMERT7) [R/W] B,H,W ----- ^{*3}	—/(TBYTE17)/ (LAMIER7) [R/W] B,H,W ----- ^{*3}	TBYTE07/(LAMRID7) / (LAMTID7) [R/W] B,H,W 00000000	
001884 _H	BGR7[R/W] H, W 00000000 00000000		—/(ISMK7)[R/W] B,H,W ----- ^{*2}	—/(ISBA7)[R/W] B,H,W ----- ^{*2}	
001888 _H	FCR17[R/W] B,H,W --00100	FCR07[R/W] B,H,W -0000000	FBYTE7[R/W] B,H,W 00000000 00000000		
00188C _H	FTICR7[R/W] B,H,W 00000000 00000000		—	—	

MB91520 Series

Address	Address offset value / Register name				Block
	+0	+1	+2	+3	
001890 _H	SCR8/(IBCR8) [R/W] B,H,W 0--00000	SMR8[R/W] B,H,W 000-00-0	SSR8[R/W] B,H,W 0-000011	ESCR8/(IBSR8)[R/W] B,H,W 00000000	Multi-UART8 *1: Byte access is possible only for access to lower 8 bits. *2: Reserved because I ² C mode is not set immediately after reset. *3: Reserved because CSIO mode is not set immediately after reset. *4: Reserved because LIN2.1 mode is not set immediately after reset.
001894 _H	—/(RDR18/(TDR18))[R/W] B,H,W ----- ^{*3}		RDR08/(TDR08)[R/W] B,H,W -----0 00000000 ^{*1}		
001898 _H	SACSR8[R/W] B,H,W 0---000 00000000		STMR8[R] B,H,W 00000000 00000000		
00189C _H	STMCR8[R/W] B,H,W 00000000 00000000		—/(SCSCR8/SFUR8)[R/W] B,H,W ----- ^{*3} *4		
0018A0 _H	—/(SCSTR38)/ (LAMSR8) [R/W] B,H,W ----- ^{*3}	—/(SCSTR28)/ (LAMCR8) [R/W] B,H,W ----- ^{*3}	—/(SCSTR18)/ (SFLR18) [R/W] B,H,W ----- ^{*3}	—/(SCSTR08)/ (SFLR08) [R/W] B,H,W ----- ^{*3}	
0018A4 _H	—	—/(SCSFR28) [R/W] B,H,W ----- ^{*3}	—/(SCSFR18) [R/W] B,H,W ----- ^{*3}	—/(SCSFR08) [R/W] B,H,W ----- ^{*3}	
0018A8 _H	—/(TBYTE38)/ (LAMESR8) [R/W] B,H,W ----- ^{*3}	—/(TBYTE28)/ (LAMERT8) [R/W] B,H,W ----- ^{*3}	—/(TBYTE18)/ (LAMIER8) [R/W] B,H,W ----- ^{*3}	TBYTE08/(LAMRID8) / (LAMTID8) [R/W] B,H,W 00000000	
0018AC _H	BGR8[R/W] H,W 00000000 00000000		—/(ISMK8)[R/W] B,H,W ----- ^{*2}	—/(ISBA8)[R/W] B,H,W ----- ^{*2}	
0018B0 _H	FCR18[R/W] B,H,W --00100	FCR08[R/W] B,H,W -0000000	FBYTE8[R/W] B,H,W 00000000 00000000		
0018B4 _H	FTICR8[R/W] B,H,W 00000000 00000000		—	—	

MB91520 Series

Address	Address offset value / Register name				Block
	+0	+1	+2	+3	
0018B8 _H	SCR9/(IBCR9) [R/W] B,H,W 0--00000	SMR9[R/W] B,H,W 000-00-0	SSR9[R/W] B,H,W 0-000011	ESCR9/(IBSR9)[R/W] B,H,W 00000000	Multi-UART9 *1: Byte access is possible only for access to lower 8 bits. *2: Reserved because I ² C mode is not set immediately after reset. *3: Reserved because CSIO mode is not set immediately after reset. *4: Reserved because LIN2.1 mode is not set immediately after reset.
0018BC _H	—/(RDR19/(TDR19))[R/W] B,H,W ----- ^{*3}		RDR09/(TDR09)[R/W] B,H,W -----0 00000000 ^{*1}		
0018C0 _H	SACSR9[R/W] B,H,W 0---000 00000000		STMR9[R] B,H,W 00000000 00000000		
0018C4 _H	STMCR9[R/W] B,H,W 00000000 00000000		—/(SCSCR9/SFUR9)[R/W] B,H,W ----- ^{*3 *4}		
0018C8 _H	—/(SCSTR39)/ (LAMSR9) [R/W] B,H,W ----- ^{*3}	—/(SCSTR29)/ (LAMCR9) [R/W] B,H,W ----- ^{*3}	—/(SCSTR19)/ (SFLR19) [R/W] B,H,W ----- ^{*3}	—/(SCSTR09)/ (SFLR09) [R/W] B,H,W ----- ^{*3}	
0018CC _H	—	—/(SCSFR29) [R/W] B,H,W ----- ^{*3}	—/(SCSFR19) [R/W] B,H,W ----- ^{*3}	—/(SCSFR09) [R/W] B,H,W ----- ^{*3}	
0018D0 _H	—/(TBYTE39)/ (LAMESR9) [R/W] B,H,W ----- ^{*3}	—/(TBYTE29)/ (LAMERT9) [R/W] B,H,W ----- ^{*3}	—/(TBYTE19)/ (LAMIER9) [R/W] B,H,W ----- ^{*3}	TBYTE09/(LAMRID9) / (LAMTID9) [R/W] B,H,W 00000000	
0018D4 _H	BGR9[R/W] H, W 00000000 00000000		—/(ISMK9)[R/W] B,H,W ----- ^{*2}	—/(ISBA9)[R/W] B,H,W ----- ^{*2}	
0018D8 _H	FCR19[R/W] B,H,W --00100	FCR09[R/W] B,H,W -0000000	FBYTE9[R/W] B,H,W 00000000 00000000		
0018DC _H	FTICR9[R/W] B,H,W 00000000 00000000		—	—	

MB91520 Series

Address	Address offset value / Register name				Block
	+0	+1	+2	+3	
0018E0 _H	SCR10/(IBCR10) [R/W] B,H,W 0--00000	SMR10[R/W] B,H,W 000-00-0	SSR10[R/W] B,H,W 0-000011	ESCR10/(IBSR10) [R/W] B,H,W 00000000	Multi-UART10 *1: Byte access is possible only for access to lower 8 bits. *2: Reserved because I ² C mode is not set immediately after reset. *3: Reserved because CSIO mode is not set immediately after reset. *4: Reserved because LIN2.1 mode is not set immediately after reset.
0018E4 _H	—/(RDR110/(TDR110))[R/W] B,H,W ----- ^{*3}		RDR010/(TDR010)[R/W] B,H,W -----0 00000000 ^{*1}		
0018E8 _H	SACSR10[R/W] B,H,W 0---000 00000000		STMR10[R] B,H,W 00000000 00000000		
0018EC _H	STMCR10[R/W] B,H,W 00000000 00000000		—/(SCSCR10/SFUR10)[R/W] B,H,W ----- ^{*3 *4}		
0018F0 _H	—/(SCSTR310)/ (LAMSR10) [R/W] B,H,W ----- ^{*3}	—/(SCSTR210)/ (LAMCR10) [R/W] B,H,W ----- ^{*3}	—/(SCSTR110)/ (SFLR110)[R/W] B,H,W ----- ^{*3}	—/(SCSTR010)/ (SFLR010)[R/W] B,H,W ----- ^{*3}	
0018F4 _H	—	—/(SCSFR210) [R/W] B,H,W ----- ^{*3}	—/(SCSFR110) [R/W] B,H,W ----- ^{*3}	—/(SCSFR010) [R/W] B,H,W ----- ^{*3}	
0018F8 _H	—/(TBYTE310)/ (LAMESR10) [R/W] B,H,W ----- ^{*3}	—/(TBYTE210)/ (LAMERT10) [R/W] B,H,W ----- ^{*3}	—/(TBYTE110)/ (LAMIER10) [R/W] B,H,W ----- ^{*3}	TBYTE010/(LAMRID10)/(LAMTID10) [R/W] B,H,W 00000000	
0018FC _H	BGR10[R/W] H, W 00000000 00000000		—/(ISMK10)[R/W] B,H,W ----- ^{*2}	—/(ISBA10)[R/W] B,H,W ----- ^{*2}	
001900 _H	FCR110[R/W] B,H,W --00100	FCR010[R/W] B,H,W -0000000	FBYTE10[R/W] B,H,W 00000000 00000000		
001904 _H	FTICR10[R/W] B,H,W 00000000 00000000		—	—	

MB91520 Series

Address	Address offset value / Register name				Block
	+0	+1	+2	+3	
001908 _H	SCR11/(IBCR11) [R/W] B,H,W 0--00000	SMR11[R/W] B,H,W 000-00-0	SSR11[R/W] B,H,W 0-000011	ESCR11/(IBSR11) [R/W] B,H,W 00000000	Multi-UART11 *1: Byte access is possible only for access to lower 8 bits. *2: Reserved because I ² C mode is not set immediately after reset. *3: Reserved because CSIO mode is not set immediately after reset. *4: Reserved because LIN2.1 mode is not set immediately after reset.
00190C _H	—/(RDR11/(TDR11))[R/W] B,H,W -----*3		RDR011/(TDR011)[R/W] B,H,W -----0 00000000 *1		
001910 _H	SACSR11[R/W] B,H,W 0---000 00000000		STMR11[R] B,H,W 00000000 00000000		
001914 _H	STMCR11[R/W] B,H,W 00000000 00000000		—/(SCSCR11/SFUR11)[R/W] B,H,W -----*3 *4		
001918 _H	—/(SCSTR311)/ (LAMSR11) [R/W] B,H,W -----*3	—/(SCSTR211)/ (LAMCR11) [R/W] B,H,W -----*3	—/(SCSTR11)/ (SFLR11)[R/W] B,H,W -----*3	—/(SCSTR011)/ (SFLR011)[R/W] B,H,W -----*3	
00191C _H	—	—/(SCSFR211) [R/W] B,H,W -----*3	—/(SCSFR11) [R/W] B,H,W -----*3	—/(SCSFR011) [R/W] B,H,W -----*3	
001920 _H	—/(TBYTE311)/ (LAMESR11) [R/W] B,H,W -----*3	—/(TBYTE211)/ (LAMERT11) [R/W] B,H,W -----*3	—/(TBYTE111)/ (LAMIER11) [R/W] B,H,W -----*3	TBYTE011/(LAMRID 11)/(LAMTID11) [R/W] B,H,W 00000000	
001924 _H	BGR11[R/W] H, W 00000000 00000000		—/(ISMK11)[R/W] B,H,W -----*2	—/(ISBA11)[R/W] B,H,W -----*2	
001928 _H	FCR11[R/W] B,H,W ---00100	FCR011[R/W] B,H,W -0000000	FBYTE11[R/W] B,H,W 00000000 00000000		
00192C _H	FTICR11[R/W] B,H,W 00000000 00000000		—	—	
001930 _H to 0019D8 _H	—	—	—	—	Reserved
0019DC _H	—	GATEC0 [R/W] B,H,W -----00	—	GATEC2 [R/W] B,H,W -----00	PPG GATE control
0019E0 _H	—	GATEC4 [R/W] B,H,W -----00	—	—	
0019E4 _H	—	—	—	—	Reserved
0019E8 _H	GTRS0 [R/W] B,H,W -0000000 -0000000		GTRS1 [R/W] B,H,W -0000000 -0000000		PPG controller
0019EC _H	GTRS2 [R/W] B,H,W -0000000 -0000000		GTRS3 [R/W] B,H,W -0000000 -0000000		
0019F0 _H	GTRS4 [R/W] B,H,W -0000000 -0000000		GTRS5 [R/W] B,H,W -0000000 -0000000		
0019F4 _H	GTRS6 [R/W] B,H,W -0000000 -0000000		GTRS7 [R/W] B,H,W -0000000 -0000000		

MB91520 Series

Address	Address offset value / Register name				Block
	+0	+1	+2	+3	
0019F8 _H	GTRS8 [R/W] B,H,W -0000000 -0000000		GTRS9 [R/W] B,H,W -0000000 -0000000		PPG controller
0019FC _H	GTRS10 [R/W] B,H,W -0000000 -0000000		GTRS11 [R/W] B,H,W -0000000 -0000000		
001A00 _H	GTRS12 [R/W] B,H,W -0000000 -0000000		GTRS13 [R/W] B,H,W -0000000 -0000000		
001A04 _H	GTRS14 [R/W] B,H,W -0000000 -0000000		GTRS15 [R/W] B,H,W -0000000 -0000000		
001A08 _H	GTRS16 [R/W] B,H,W -0000000 -0000000		GTRS17 [R/W] B,H,W -0000000 -0000000		
001A0C _H	GTRS18 [R/W] B,H,W -0000000 -0000000		GTRS19 [R/W] B,H,W -0000000 -0000000		
001A10 _H	GTRS20 [R/W] B,H,W -0000000 -0000000		GTRS21 [R/W] B,H,W -0000000 -0000000		
001A14 _H	GTRS22 [R/W] B,H,W -0000000 -0000000		GTRS23 [R/W] B,H,W -0000000 -0000000		
001A18 _H to 001A2C _H	—	—	—	—	Reserved
001A30 _H	—	—	—	—	Reserved
001A34 _H	—	—	—	—	
001A38 _H	GTREN0 [R/W] H,W 00000000 00000000		GTREN1 [R/W] H,W 00000000 00000000		PPG controller
001A3C _H	GTREN2 [R/W] H,W 00000000 00000000		—	—	
001A40 _H	PCN0 [R/W] B,H,W 00000000 000000-0		PCSR0 [W] H,W XXXXXXXXXX XXXXXXXXXXXX		PPG0 * for communication
001A44 _H	PDUT0 [W] H,W XXXXXXXXXX XXXXXXXXXXXX		PTMR0 [R] H,W 11111111 11111111		
001A48 _H	PCN200 [R/W] B,H,W --000000 ----110		PSDR0 [R/W] H,W 00000000 00000000		
001A4C _H	PTPC0 [R/W] H,W 00000000 00000000		PCMDWD0 [R/W] B,H,W ----- ----0000		
001A50 _H	PHCSR0 [W] H,W XXXXXXXXXX XXXXXXXXXXXX		PLCSR0 [W] H,W XXXXXXXXXX XXXXXXXXXXXX		
001A54 _H	PHDUT0 [W] H,W XXXXXXXXXX XXXXXXXXXXXX		PLDUT0 [W] H,W XXXXXXXXXX XXXXXXXXXXXX		
001A58 _H	PCMDDT0 [R/W] H,W 00000000 00000000		—	—	
001A5C _H	PCN1 [R/W] B,H,W 00000000 000000-0		PCSR1 [W] H,W XXXXXXXXXX XXXXXXXXXXXX		PPG1 * for communication
001A60 _H	PDUT1 [W] H,W XXXXXXXXXX XXXXXXXXXXXX		PTMR1 [R] H,W 11111111 11111111		

MB91520 Series

Address	Address offset value / Register name				Block
	+0	+1	+2	+3	
001A64 _H	PCN201 [R/W] B,H,W --000000 -----110		PSDR1 [R/W] H,W 00000000 00000000		PPG1 * for communication
001A68 _H	PTPC1 [R/W] H,W 00000000 00000000		PCMDWD1 [R/W] B,H,W ----- ----0000		
001A6C _H	PHCSR1 [W] H,W XXXXXXXX XXXXXXXX		PLCSR1 [W] H,W XXXXXXXX XXXXXXXX		
001A70 _H	PHDUT1 [W] H,W XXXXXXXX XXXXXXXX		PLDUT1 [W] H,W XXXXXXXX XXXXXXXX		
001A74 _H	PCMDDT1 [R/W] H,W 00000000 00000000		—	—	
001A78 _H	PCN2 [R/W] B,H,W 00000000 000000-0		PCSR2 [W] H,W XXXXXXXX XXXXXXXX		PPG2 * for communication
001A7C _H	PDUT2 [W] H,W XXXXXXXX XXXXXXXX		PTMR2 [R] H,W 11111111 11111111		
001A80 _H	PCN202 [R/W] B,H,W --000000 -----110		PSDR2 [R/W] H,W 00000000 00000000		
001A84 _H	PTPC2 [R/W] H,W 00000000 00000000		PCMDWD2 [R/W] B,H,W ----- ----0000		
001A88 _H	PHCSR2 [W] H,W XXXXXXXX XXXXXXXX		PLCSR2 [W] H,W XXXXXXXX XXXXXXXX		
001A8C _H	PHDUT2 [W] H,W XXXXXXXX XXXXXXXX		PLDUT2 [W] H,W XXXXXXXX XXXXXXXX		
001A90 _H	PCMDDT2 [R/W] H,W 00000000 00000000		—	—	PPG3 * for communication
001A94 _H	PCN3 [R/W] B,H,W 00000000 000000-0		PCSR3 [W] H,W XXXXXXXX XXXXXXXX		
001A98 _H	PDUT3 [W] H,W XXXXXXXX XXXXXXXX		PTMR3 [R] H,W 11111111 11111111		
001A9C _H	PCN203 [R/W] B,H,W --000000 -----110		PSDR3 [R/W] H,W 00000000 00000000		
001AA0 _H	PTPC3 [R/W] H,W 00000000 00000000		PCMDWD3 [R/W] B,H,W ----- ----0000		
001AA4 _H	PHCSR3 [W] H,W XXXXXXXX XXXXXXXX		PLCSR3 [W] H,W XXXXXXXX XXXXXXXX		
001AA8 _H	PHDUT3 [W] H,W XXXXXXXX XXXXXXXX		PLDUT3 [W] H,W XXXXXXXX XXXXXXXX		
001AAC _H	PCMDDT3 [R/W] H,W 00000000 00000000		—	—	PPG4
001AB0 _H	PCN4 [R/W] B,H,W 00000000 000000-0		PCSR4 [W] H,W XXXXXXXX XXXXXXXX		
001AB4 _H	PDUT4 [W] H,W XXXXXXXX XXXXXXXX		PTMR4 [R] H,W 11111111 11111111		
001AB8 _H	PCN204 [R/W] B,H,W --000000 -----110		PSDR4 [R/W] H,W 00000000 00000000		

MB91520 Series

Address	Address offset value / Register name				Block
	+0	+1	+2	+3	
001ABC _H	PTPC4 [R/W] H,W 00000000 00000000		—	—	PPG4
001AC0 _H	PCN5 [R/W] B,H,W 00000000 000000-0		PCSR5 [W] H,W XXXXXXXX XXXXXXXX		PPG5
001AC4 _H	PDUT5 [W] H,W XXXXXXXX XXXXXXXX		PTMR5 [R] H,W 11111111 11111111		
001AC8 _H	PCN205 [R/W] B,H,W --000000 ----110		PSDR5 [R/W] H,W 00000000 00000000		
001ACC _H	PTPC5 [R/W] H,W 00000000 00000000		—	—	
001AD0 _H	PCN6 [R/W] B,H,W 00000000 000000-0		PCSR6 [W] H,W XXXXXXXX XXXXXXXX		PPG6
001AD4 _H	PDUT6 [W] H,W XXXXXXXX XXXXXXXX		PTMR6 [R] H,W 11111111 11111111		
001AD8 _H	PCN206 [R/W] B,H,W --000000 ----110		PSDR6 [R/W] H,W 00000000 00000000		
001ADC _H	PTPC6 [R/W] H,W 00000000 00000000		—	—	
001AE0 _H	PCN7 [R/W] B,H,W 00000000 000000-0		PCSR7 [W] H,W XXXXXXXX XXXXXXXX		PPG7
001AE4 _H	PDUT7 [W] H,W XXXXXXXX XXXXXXXX		PTMR7 [R] H,W 11111111 11111111		
001AE8 _H	PCN207 [R/W] B,H,W --000000 ----110		PSDR7 [R/W] H,W 00000000 00000000		
001AEC _H	PTPC7 [R/W] H,W 00000000 00000000		—	—	
001AF0 _H	PCN8 [R/W] B,H,W 00000000 000000-0		PCSR8 [W] H,W XXXXXXXX XXXXXXXX		PPG8
001AF4 _H	PDUT8 [W] H,W XXXXXXXX XXXXXXXX		PTMR8 [R] H,W 11111111 11111111		
001AF8 _H	PCN208 [R/W] B,H,W --000000 ----110		PSDR8 [R/W] H,W 00000000 00000000		
001AFC _H	PTPC8 [R/W] H,W 00000000 00000000		—	—	
001B00 _H	PCN9 [R/W] B,H,W 00000000 000000-0		PCSR9 [W] H,W XXXXXXXX XXXXXXXX		PPG9
001B04 _H	PDUT9 [W] H,W XXXXXXXX XXXXXXXX		PTMR9 [R] H,W 11111111 11111111		
001B08 _H	PCN209 [R/W] B,H,W --000000 ----110		PSDR9 [R/W] H,W 00000000 00000000		
001B0C _H	PTPC9 [R/W] H,W 00000000 00000000		—	—	
001B10 _H	PCN10 [R/W] B,H,W 00000000 000000-0		PCSR10 [W] H,W XXXXXXXX XXXXXXXX		PPG10
001B14 _H	PDUT10 [W] H,W XXXXXXXX XXXXXXXX		PTMR10 [R] H,W 11111111 11111111		

MB91520 Series

Address	Address offset value / Register name				Block
	+0	+1	+2	+3	
001B18 _H	PCN210 [R/W] B,H,W --000000 -----110		PSDR10 [R/W] H,W 00000000 00000000		PPG10
001B1C _H	PTPC10 [R/W] H,W 00000000 00000000		—	—	
001B20 _H	PCN11 [R/W] B,H,W 00000000 000000-0		PCSR11 [W] H,W XXXXXXXXXX XXXXXXXXXXXX		PPG11
001B24 _H	PDUT11 [W] H,W XXXXXXXXXX XXXXXXXXXXXX		PTMR11 [R] H,W 11111111 11111111		
001B28 _H	PCN211 [R/W] B,H,W --000000 -----110		PSDR11 [R/W] H,W 00000000 00000000		
001B2C _H	PTPC11 [R/W] H,W 00000000 00000000		—	—	PPG12
001B30 _H	PCN12 [R/W] B,H,W 00000000 000000-0		PCSR12 [W] H,W XXXXXXXXXX XXXXXXXXXXXX		
001B34 _H	PDUT12 [W] H,W XXXXXXXXXX XXXXXXXXXXXX		PTMR12 [R] H,W 11111111 11111111		
001B38 _H	PCN212 [R/W] B,H,W --000000 -----110		PSDR12 [R/W] H,W 00000000 00000000		PPG13
001B3C _H	PTPC12 [R/W] H,W 00000000 00000000		—	—	
001B40 _H	PCN13 [R/W] B,H,W 00000000 000000-0		PCSR13 [W] H,W XXXXXXXXXX XXXXXXXXXXXX		
001B44 _H	PDUT13 [W] H,W XXXXXXXXXX XXXXXXXXXXXX		PTMR13 [R] H,W 11111111 11111111		PPG14
001B48 _H	PCN213 [R/W] B,H,W --000000 -----110		PSDR13 [R/W] H,W 00000000 00000000		
001B4C _H	PTPC13 [R/W] H,W 00000000 00000000		—	—	
001B50 _H	PCN14 [R/W] B,H,W 00000000 000000-0		PCSR14 [W] H,W XXXXXXXXXX XXXXXXXXXXXX		PPG15
001B54 _H	PDUT14 [W] H,W XXXXXXXXXX XXXXXXXXXXXX		PTMR14 [R] H,W 11111111 11111111		
001B58 _H	PCN214 [R/W] B,H,W --000000 -----110		PSDR14 [R/W] H,W 00000000 00000000		
001B5C _H	PTPC14 [R/W] H,W 00000000 00000000		—	—	PPG16
001B60 _H	PCN15 [R/W] B,H,W 00000000 000000-0		PCSR15 [W] H,W XXXXXXXXXX XXXXXXXXXXXX		
001B64 _H	PDUT15 [W] H,W XXXXXXXXXX XXXXXXXXXXXX		PTMR15 [R] H,W 11111111 11111111		
001B68 _H	PCN215 [R/W] B,H,W --000000 -----110		PSDR15 [R/W] H,W 00000000 00000000		PPG15
001B6C _H	PTPC15 [R/W] H,W 00000000 00000000		—	—	
001B70 _H	PCN16 [R/W] B,H,W 00000000 000000-0		PCSR16 [W] H,W XXXXXXXXXX XXXXXXXXXXXX		PPG16

MB91520 Series

Address	Address offset value / Register name				Block
	+0	+1	+2	+3	
001B74 _H	PDUT16 [W] H,W XXXXXXXX XXXXXXXX		PTMR16 [R] H,W 1111111 1111111		PPG16
001B78 _H	PCN216 [R/W] B,H,W --000000 ----110		PSDR16 [R/W] H,W 00000000 00000000		
001B7C _H	PTPC16 [R/W] H,W 00000000 00000000		—	—	
001B80 _H	PCN17 [R/W] B,H,W 00000000 000000-0		PCSR17 [W] H,W XXXXXXXX XXXXXXXX		PPG17
001B84 _H	PDUT17 [W] H,W XXXXXXXX XXXXXXXX		PTMR17 [R] H,W 1111111 1111111		
001B88 _H	PCN217 [R/W] B,H,W --000000 ----110		PSDR17 [R/W] H,W 00000000 00000000		
001B8C _H	PTPC17 [R/W] H,W 00000000 00000000		—	—	PPG18
001B90 _H	PCN18 [R/W] B,H,W 00000000 000000-0		PCSR18 [W] H,W XXXXXXXX XXXXXXXX		
001B94 _H	PDUT18 [W] H,W XXXXXXXX XXXXXXXX		PTMR18 [R] H,W 1111111 1111111		
001B98 _H	PCN218 [R/W] B,H,W --000000 ----110		PSDR18 [R/W] H,W 00000000 00000000		PPG19
001B9C _H	PTPC18 [R/W] H,W 00000000 00000000		—	—	
001BA0 _H	PCN19 [R/W] B,H,W 00000000 000000-0		PCSR19 [W] H,W XXXXXXXX XXXXXXXX		
001BA4 _H	PDUT19 [W] H,W XXXXXXXX XXXXXXXX		PTMR19 [R] H,W 1111111 1111111		PPG20
001BA8 _H	PCN219 [R/W] B,H,W --000000 ----110		PSDR19 [R/W] H,W 00000000 00000000		
001BAC _H	PTPC19 [R/W] H,W 00000000 00000000		—	—	
001BB0 _H	PCN20 [R/W] B,H,W 00000000 000000-0		PCSR20 [W] H,W XXXXXXXX XXXXXXXX		PPG21
001BB4 _H	PDUT20 [W] H,W XXXXXXXX XXXXXXXX		PTMR20 [R] H,W 1111111 1111111		
001BB8 _H	PCN220 [R/W] B,H,W --000000 ----110		PSDR20 [R/W] H,W 00000000 00000000		
001BBC _H	PTPC20 [R/W] H,W 00000000 00000000		—	—	PPG21
001BC0 _H	PCN21 [R/W] B,H,W 00000000 000000-0		PCSR21 [W] H,W XXXXXXXX XXXXXXXX		
001BC4 _H	PDUT21 [W] H,W XXXXXXXX XXXXXXXX		PTMR21 [R] H,W 1111111 1111111		
001BC8 _H	PCN221 [R/W] B,H,W --000000 ----110		PSDR21 [R/W] H,W 00000000 00000000		
001BCC _H	PTPC21 [R/W] H,W 00000000 00000000		—	—	

MB91520 Series

Address	Address offset value / Register name				Block
	+0	+1	+2	+3	
001BD0 _H	PCN22 [R/W] B,H,W 00000000 000000-0		PCSR22 [W] H,W XXXXXXXXXX XXXXXXXXXXXX		PPG22
001BD4 _H	PDUT22 [W] H,W XXXXXXXXXX XXXXXXXXXXXX		PTMR22 [R] H,W 11111111 11111111		
001BD8 _H	PCN222 [R/W] B,H,W --000000 ----110		PSDR22 [R/W] H,W 00000000 00000000		
001BDC _H	PTPC22 [R/W] H,W 00000000 00000000		—	—	
001BE0 _H	PCN23 [R/W] B,H,W 00000000 000000-0		PCSR23 [W] H,W XXXXXXXXXX XXXXXXXXXXXX		PPG23
001BE4 _H	PDUT23 [W] H,W XXXXXXXXXX XXXXXXXXXXXX		PTMR23 [R] H,W 11111111 11111111		
001BE8 _H	PCN223 [R/W] B,H,W --000000 ----110		PSDR23 [R/W] H,W 00000000 00000000		
001BEC _H	PTPC23 [R/W] H,W 00000000 00000000		—	—	
001BF0 _H	PCN24 [R/W] B,H,W 00000000 000000-0		PCSR24 [W] H,W XXXXXXXXXX XXXXXXXXXXXX		PPG24
001BF4 _H	PDUT24 [W] H,W XXXXXXXXXX XXXXXXXXXXXX		PTMR24 [R] H,W 11111111 11111111		
001BF8 _H	PCN224 [R/W] B,H,W --000000 ----110		PSDR24 [R/W] H,W 00000000 00000000		
001BFC _H	PTPC24 [R/W] H,W 00000000 00000000		—	—	
001C00 _H	PCN25 [R/W] B,H,W 00000000 000000-0		PCSR25 [W] H,W XXXXXXXXXX XXXXXXXXXXXX		PPG25
001C04 _H	PDUT25 [W] H,W XXXXXXXXXX XXXXXXXXXXXX		PTMR25 [R] H,W 11111111 11111111		
001C08 _H	PCN225 [R/W] B,H,W --000000 ----110		PSDR25 [R/W] H,W 00000000 00000000		
001C0C _H	PTPC25 [R/W] H,W 00000000 00000000		—	—	
001C10 _H	PCN26 [R/W] B,H,W 00000000 000000-0		PCSR26 [W] H,W XXXXXXXXXX XXXXXXXXXXXX		PPG26
001C14 _H	PDUT26 [W] H,W XXXXXXXXXX XXXXXXXXXXXX		PTMR26 [R] H,W 11111111 11111111		
001C18 _H	PCN226 [R/W] B,H,W --000000 ----110		PSDR26 [R/W] H,W 00000000 00000000		
001C1C _H	PTPC26 [R/W] H,W 00000000 00000000		—	—	
001C20 _H	PCN27 [R/W] B,H,W 00000000 000000-0		PCSR27 [W] H,W XXXXXXXXXX XXXXXXXXXXXX		PPG27
001C24 _H	PDUT27 [W] H,W XXXXXXXXXX XXXXXXXXXXXX		PTMR27 [R] H,W 11111111 11111111		
001C28 _H	PCN227 [R/W] B,H,W --000000 ----110		PSDR27 [R/W] H,W 00000000 00000000		
001C2C _H	PTPC27 [R/W] H,W 00000000 00000000		—	—	

MB91520 Series

Address	Address offset value / Register name				Block
	+0	+1	+2	+3	
001C30 _H	PCN28 [R/W] B,H,W 00000000 000000-0		PCSR28 [W] H,W XXXXXXXXXX XXXXXXXXXXXX		PPG28
001C34 _H	PDUT28 [W] H,W XXXXXXXXXX XXXXXXXXXXXX		PTMR28 [R] H,W 11111111 11111111		
001C38 _H	PCN228 [R/W] B,H,W --000000 ----110		PSDR28 [R/W] H,W 00000000 00000000		
001C3C _H	PTPC28 [R/W] H,W 00000000 00000000		—	—	
001C40 _H	PCN29 [R/W] B,H,W 00000000 000000-0		PCSR29 [W] H,W XXXXXXXXXX XXXXXXXXXXXX		PPG29
001C44 _H	PDUT29 [W] H,W XXXXXXXXXX XXXXXXXXXXXX		PTMR29 [R] H,W 11111111 11111111		
001C48 _H	PCN229 [R/W] B,H,W --000000 ----110		PSDR29 [R/W] H,W 00000000 00000000		
001C4C _H	PTPC29 [R/W] H,W 00000000 00000000		—	—	
001C50 _H	PCN30 [R/W] B,H,W 00000000 000000-0		PCSR30 [W] H,W XXXXXXXXXX XXXXXXXXXXXX		PPG30
001C54 _H	PDUT30 [W] H,W XXXXXXXXXX XXXXXXXXXXXX		PTMR30 [R] H,W 11111111 11111111		
001C58 _H	PCN230 [R/W] B,H,W --000000 ----110		PSDR30 [R/W] H,W 00000000 00000000		
001C5C _H	PTPC30 [R/W] H,W 00000000 00000000		—	—	
001C60 _H	PCN31 [R/W] B,H,W 00000000 000000-0		PCSR31 [W] H,W XXXXXXXXXX XXXXXXXXXXXX		PPG31
001C64 _H	PDUT31 [W] H,W XXXXXXXXXX XXXXXXXXXXXX		PTMR31 [R] H,W 11111111 11111111		
001C68 _H	PCN231 [R/W] B,H,W --000000 ----110		PSDR31 [R/W] H,W 00000000 00000000		
001C6C _H	PTPC31 [R/W] H,W 00000000 00000000		—	—	
001C70 _H	PCN32 [R/W] B,H,W 00000000 000000-0		PCSR32 [W] H,W XXXXXXXXXX XXXXXXXXXXXX		PPG32
001C74 _H	PDUT32 [W] H,W XXXXXXXXXX XXXXXXXXXXXX		PTMR32 [R] H,W 11111111 11111111		
001C78 _H	PCN232 [R/W] B,H,W --000000 ----110		PSDR32 [R/W] H,W 00000000 00000000		
001C7C _H	PTPC32 [R/W] H,W 00000000 00000000		—	—	
001C80 _H	PCN33 [R/W] B,H,W 00000000 000000-0		PCSR33 [W] H,W XXXXXXXXXX XXXXXXXXXXXX		PPG33
001C84 _H	PDUT33 [W] H,W XXXXXXXXXX XXXXXXXXXXXX		PTMR33 [R] H,W 11111111 11111111		
001C88 _H	PCN233 [R/W] B,H,W --000000 ----110		PSDR33 [R/W] H,W 00000000 00000000		

MB91520 Series

Address	Address offset value / Register name				Block
	+0	+1	+2	+3	
001C8C _H	PTPC33 [R/W] H,W 00000000 00000000		—	—	PPG33
001C90 _H	PCN34 [R/W] B,H,W 00000000 000000-0		PCSR34 [W] H,W XXXXXXXX XXXXXXXX		PPG34
001C94 _H	PDUT34 [W] H,W XXXXXXXX XXXXXXXX		PTMR34 [R] H,W 11111111 11111111		
001C98 _H	PCN234 [R/W] B,H,W --000000 ----110		PSDR34 [R/W] H,W 00000000 00000000		
001C9C _H	PTPC34 [R/W] H,W 00000000 00000000		—	—	
001CA0 _H	PCN35 [R/W] B,H,W 00000000 000000-0		PCSR35 [W] H,W XXXXXXXX XXXXXXXX		PPG35
001CA4 _H	PDUT35 [W] H,W XXXXXXXX XXXXXXXX		PTMR35 [R] H,W 11111111 11111111		
001CA8 _H	PCN235 [R/W] B,H,W --000000 ----110		PSDR35 [R/W] H,W 00000000 00000000		
001CAC _H	PTPC35 [R/W] H,W 00000000 00000000		—	—	
001CB0 _H	PCN36 [R/W] B,H,W 00000000 000000-0		PCSR36 [W] H,W XXXXXXXX XXXXXXXX		PPG36
001CB4 _H	PDUT36 [W] H,W XXXXXXXX XXXXXXXX		PTMR36 [R] H,W 11111111 11111111		
001CB8 _H	PCN236 [R/W] B,H,W --000000 ----110		PSDR36 [R/W] H,W 00000000 00000000		
001CBC _H	PTPC36 [R/W] H,W 00000000 00000000		—	—	
001CC0 _H	PCN37 [R/W] B,H,W 00000000 000000-0		PCSR37 [W] H,W XXXXXXXX XXXXXXXX		PPG37
001CC4 _H	PDUT37 [W] H,W XXXXXXXX XXXXXXXX		PTMR37 [R] H,W 11111111 11111111		
001CC8 _H	PCN237 [R/W] B,H,W --000000 ----110		PSDR37 [R/W] H,W 00000000 00000000		
001CCC _H	PTPC37 [R/W] H,W 00000000 00000000		—	—	
001CD0 _H	PCN38 [R/W] B,H,W 00000000 000000-0		PCSR38 [W] H,W XXXXXXXX XXXXXXXX		PPG38
001CD4 _H	PDUT38 [W] H,W XXXXXXXX XXXXXXXX		PTMR38 [R] H,W 11111111 11111111		
001CD8 _H	PCN238 [R/W] B,H,W --000000 ----110		PSDR38 [R/W] H,W 00000000 00000000		
001CDC _H	PTPC38 [R/W] H,W 00000000 00000000		—	—	
001CE0 _H	PCN39 [R/W] B,H,W 00000000 000000-0		PCSR39 [W] H,W XXXXXXXX XXXXXXXX		PPG39
001CE4 _H	PDUT39 [W] H,W XXXXXXXX XXXXXXXX		PTMR39 [R] H,W 11111111 11111111		

MB91520 Series

Address	Address offset value / Register name				Block
	+0	+1	+2	+3	
001CE8 _H	PCN239 [R/W] B,H,W --000000 ----110		PSDR39 [R/W] H,W 00000000 00000000		PPG39
001CEC _H	PTPC39 [R/W] H,W 00000000 00000000		—	—	
001CF0 _H	PCN40 [R/W] B,H,W 00000000 000000-0		PCSR40 [W] H,W XXXXXXXX XXXXXXXX		PPG40
001CF4 _H	PDUT40 [W] H,W XXXXXXXX XXXXXXXX		PTMR40 [R] H,W 11111111 11111111		
001CF8 _H	PCN240 [R/W] B,H,W --000000 ----110		PSDR40 [R/W] H,W 00000000 00000000		
001CFC _H	PTPC40 [R/W] H,W 00000000 00000000		—	—	
001D00 _H	PCN41 [R/W] B,H,W 00000000 000000-0		PCSR41 [W] H,W XXXXXXXX XXXXXXXX		PPG41
001D04 _H	PDUT41 [W] H,W XXXXXXXX XXXXXXXX		PTMR41 [R] H,W 11111111 11111111		
001D08 _H	PCN241 [R/W] B,H,W --000000 ----110		PSDR41 [R/W] H,W 00000000 00000000		
001D0C _H	PTPC41 [R/W] H,W 00000000 00000000		—	—	
001D10 _H	PCN42 [R/W] B,H,W 00000000 000000-0		PCSR42 [W] H,W XXXXXXXX XXXXXXXX		PPG42
001D14 _H	PDUT42 [W] H,W XXXXXXXX XXXXXXXX		PTMR42 [R] H,W 11111111 11111111		
001D18 _H	PCN242 [R/W] B,H,W --000000 ----110		PSDR42 [R/W] H,W 00000000 00000000		
001D1C _H	PTPC42 [R/W] H,W 00000000 00000000		—	—	
001D20 _H	PCN43 [R/W] B,H,W 00000000 000000-0		PCSR43 [W] H,W XXXXXXXX XXXXXXXX		PPG43
001D24 _H	PDUT43 [W] H,W XXXXXXXX XXXXXXXX		PTMR43 [R] H,W 11111111 11111111		
001D28 _H	PCN243 [R/W] B,H,W --000000 ----110		PSDR43 [R/W] H,W 00000000 00000000		
001D2C _H	PTPC43 [R/W] H,W 00000000 00000000		—	—	
001D30 _H	PCN44 [R/W] B,H,W 00000000 000000-0		PCSR44 [W] H,W XXXXXXXX XXXXXXXX		PPG44
001D34 _H	PDUT44 [W] H,W XXXXXXXX XXXXXXXX		PTMR44 [R] H,W 11111111 11111111		
001D38 _H	PCN244 [R/W] B,H,W --000000 ----110		PSDR44 [R/W] H,W 00000000 00000000		
001D3C _H	PTPC44 [R/W] H,W 00000000 00000000		—	—	
001D40 _H	PCN45 [R/W] B,H,W 00000000 000000-0		PCSR45 [W] H,W XXXXXXXX XXXXXXXX		PPG45

MB91520 Series

Address	Address offset value / Register name				Block
	+0	+1	+2	+3	
001D44 _H	PDUT45 [W] H,W XXXXXXXX XXXXXXXX		PTMR45 [R] H,W 11111111 11111111		PPG45
001D48 _H	PCN245 [R/W] B,H,W --000000 ----110		PSDR45 [R/W] H,W 00000000 00000000		
001D4C _H	PTPC45 [R/W] H,W 00000000 00000000		—	—	
001D50 _H	PCN46 [R/W] B,H,W 00000000 000000-0		PCSR46 [W] H,W XXXXXXXX XXXXXXXX		PPG46
001D54 _H	PDUT46 [W] H,W XXXXXXXX XXXXXXXX		PTMR46 [R] H,W 11111111 11111111		
001D58 _H	PCN246 [R/W] B,H,W --000000 ----110		PSDR46 [R/W] H,W 00000000 00000000		
001D5C _H	PTPC46 [R/W] H,W 00000000 00000000		—	—	
001D60 _H	PCN47 [R/W] B,H,W 00000000 000000-0		PCSR47 [W] H,W XXXXXXXX XXXXXXXX		PPG47
001D64 _H	PDUT47 [W] H,W XXXXXXXX XXXXXXXX		PTMR47 [R] H,W 11111111 11111111		
001D68 _H	PCN247 [R/W] B,H,W --000000 ----110		PSDR47 [R/W] H,W 00000000 00000000		
001D6C _H	PTPC47 [R/W] H,W 00000000 00000000		—	—	
001D70 _H to 001FFC _H	—	—	—	—	Reserved
002000 _H	CTRLR0 [R/W] B,H,W ----- 000-0001		STATR0 [R/W] B,H,W ----- 00000000		CAN0 (128msb)
002004 _H	ERRCNT0 [R] B,H,W 00000000 00000000		BTR0 [R/W] B,H,W -0100011 00000001		
002008 _H	INTR0 [R] B,H,W 00000000 00000000		TESTR0 [R/W] B,H,W ----- X00000--		
00200C _H	BRPER0 [R/W] B,H,W ----- ----0000		—	—	
002010 _H	IF1CREQ0 [R/W] B,H,W 0----- 00000001		IF1CMSK0 [R/W] B,H,W ----- 00000000		
002014 _H	IF1MSK20 [R/W] B,H,W 11-111111 11111111		IF1MSK10 [R/W] B,H,W 11111111 11111111		
002018 _H	IF1ARB20 [R/W] B,H,W 00000000 00000000		IF1ARB10 [R/W] B,H,W 00000000 00000000		
00201C _H	IF1MCTR0 [R/W] B,H,W 00000000 0---0000		—	—	
002020 _H	IF1DTA10 [R/W] B,H,W 00000000 00000000		IF1DTA20 [R/W] B,H,W 00000000 00000000		
002024 _H	IF1DTB10 [R/W] B,H,W 00000000 00000000		IF1DTB20 [R/W] B,H,W 00000000 00000000		

MB91520 Series

Address	Address offset value / Register name				Block
	+0	+1	+2	+3	
002028 _H	—	—	—	—	CAN0 (128msb)
00202C _H	—	—	—	—	
002030 _H , 002034 _H	Reserved(IF1 data mirror)				
002038 _H	—	—	—	—	
00203C _H	—	—	—	—	
002040 _H	IF2CREQ0 [R/W] B,H,W 0----- 00000001		IF2CMSK0 [R/W] B,H,W ----- 00000000		
002044 _H	IF2MSK20 [R/W] B,H,W 11-11111 11111111		IF2MSK10 [R/W] B,H,W 11111111 11111111		
002048 _H	IF2ARB20 [R/W] B,H,W 00000000 00000000		IF2ARB10 [R/W] B,H,W 00000000 00000000		
00204C _H	IF2MCTR0 [R/W] B,H,W 00000000 0---0000		—	—	
002050 _H	IF2DTA10 [R/W] B,H,W 00000000 00000000		IF2DTA20 [R/W] B,H,W 00000000 00000000		
002054 _H	IF2DTB10 [R/W] B,H,W 00000000 00000000		IF2DTB20 [R/W] B,H,W 00000000 00000000		
002058 _H	—	—	—	—	
00205C _H	—	—	—	—	
002060 _H , 002064 _H	Reserved(IF2 data mirror)				
002068 _H to 00207C _H	—				
002080 _H	TREQR20 [R] B,H,W 00000000 00000000		TREQR10 [R] B,H,W 00000000 00000000		
002084 _H	TREQR40 [R] B,H,W 00000000 00000000		TREQR30 [R] B,H,W 00000000 00000000		
002088 _H	TREQR60 [R] B,H,W 00000000 00000000		TREQR50 [R] B,H,W 00000000 00000000		
00208C _H	TREQR80 [R] B,H,W 00000000 00000000		TREQR70 [R] B,H,W 00000000 00000000		
002090 _H	NEWDT20 [R] B,H,W 00000000 00000000		NEWDT10 [R] B,H,W 00000000 00000000		
002094 _H	NEWDT40 [R] B,H,W 00000000 00000000		NEWDT30 [R] B,H,W 00000000 00000000		
002098 _H	NEWDT60 [R] B,H,W 00000000 00000000		NEWDT50 [R] B,H,W 00000000 00000000		
00209C _H	NEWDT80 [R] B,H,W 00000000 00000000		NEWDT70 [R] B,H,W 00000000 00000000		
0020A0 _H	INTPND20 [R] B,H,W 00000000 00000000		INTPND10 [R] B,H,W 00000000 00000000		

MB91520 Series

Address	Address offset value / Register name				Block
	+0	+1	+2	+3	
0020A4 _H	INTPND40 [R] B,H,W 00000000 00000000		INTPND30 [R] B,H,W 00000000 00000000		CAN0 (128msb)
0020A8 _H	INTPND60 [R] B,H,W 00000000 00000000		INTPND50 [R] B,H,W 00000000 00000000		
0020AC _H	INTPND80 [R] B,H,W 00000000 00000000		INTPND70 [R] B,H,W 00000000 00000000		
0020B0 _H	MSGVAL20 [R] B,H,W 00000000 00000000		MSGVAL10 [R] B,H,W 00000000 00000000		
0020B4 _H	MSGVAL40 [R] B,H,W 00000000 00000000		MSGVAL30 [R] B,H,W 00000000 00000000		
0020B8 _H	MSGVAL60 [R] B,H,W 00000000 00000000		MSGVAL50 [R] B,H,W 00000000 00000000		
0020BC _H	MSGVAL80 [R] B,H,W 00000000 00000000		MSGVAL70 [R] B,H,W 00000000 00000000		
0020C0 _H to 0020FC _H	—				
002100 _H	CTRLR1 [R/W] B,H,W ----- 000-0001		STATR1 [R/W] B,H,W ----- 00000000		CAN1 (64msb)
002104 _H	ERRCNT1 [R] B,H,W 00000000 00000000		BTR1 [R/W] B,H,W -0100011 00000001		
002108 _H	INTR1 [R] B,H,W 00000000 00000000		TESTR1 [R/W] B,H,W ----- X00000--		
00210C _H	BRPER1 [R/W] B,H,W ----- ----0000		—	—	
002110 _H	IF1CREQ1 [R/W] B,H,W 0----- 00000001		IF1CMSK1 [R/W] B,H,W ----- 00000000		
002114 _H	IF1MSK21 [R/W] B,H,W 11-11111 11111111		IF1MSK11 [R/W] B,H,W 11111111 11111111		
002118 _H	IF1ARB21 [R/W] B,H,W 00000000 00000000		IF1ARB11 [R/W] B,H,W 00000000 00000000		
00211C _H	IF1MCTR1 [R/W] B,H,W 00000000 0---0000		—	—	
002120 _H	IF1DTA11 [R/W] B,H,W 00000000 00000000		IF1DTA21 [R/W] B,H,W 00000000 00000000		
002124 _H	IF1DTB11 [R/W] B,H,W 00000000 00000000		IF1DTB21 [R/W] B,H,W 00000000 00000000		
002128 _H	—	—	—	—	
00212C _H	—	—	—	—	
002130 _H , 002134 _H	Reserved (IF1 data mirror)				
002138 _H	—	—	—	—	
00213C _H	—	—	—	—	

MB91520 Series

Address	Address offset value / Register name				Block
	+0	+1	+2	+3	
002140 _H	IF2CREQ1 [R/W] B,H,W 0----- 00000001		IF2CMSK1 [R/W] B,H,W ----- 00000000		CAN1 (64msb)
002144 _H	IF2MSK21 [R/W] B,H,W 11-11111 11111111		IF2MSK11 [R/W] B,H,W 11111111 11111111		
002148 _H	IF2ARB21 [R/W] B,H,W 00000000 00000000		IF2ARB11 [R/W] B,H,W 00000000 00000000		
00214C _H	IF2MCTR1 [R/W] B,H,W 00000000 0---0000		—	—	
002150 _H	IF2DTA11 [R/W] B,H,W 00000000 00000000		IF2DTA21 [R/W] B,H,W 00000000 00000000		
002154 _H	IF2DTB11 [R/W] B,H,W 00000000 00000000		IF2DTB21 [R/W] B,H,W 00000000 00000000		
002158 _H	—	—	—	—	
00215C _H	—	—	—	—	
002160 _H , 002164 _H	Reserved (IF2 data mirror)				
002168 _H to 00217C _H	—				
002180 _H	TREQR21 [R] B,H,W 00000000 00000000		TREQR11 [R] B,H,W 00000000 00000000		
002184 _H	TREQR41 [R] B,H,W 00000000 00000000		TREQR31 [R] B,H,W 00000000 00000000		
002188 _H	—	—	—	—	
00218C _H	—	—	—	—	
002190 _H	NEWDT21 [R] B,H,W 00000000 00000000		NEWDT11 [R] B,H,W 00000000 00000000		
002194 _H	NEWDT41 [R] B,H,W 00000000 00000000		NEWDT31 [R] B,H,W 00000000 00000000		
002198 _H	—	—	—	—	
00219C _H	—	—	—	—	
0021A0 _H	INTPND21 [R] B,H,W 00000000 00000000		INTPND11 [R] B,H,W 00000000 00000000		
0021A4 _H	INTPND41 [R] B,H,W 00000000 00000000		INTPND31 [R] B,H,W 00000000 00000000		
0021A8 _H	—	—	—	—	
0021AC _H	—	—	—	—	
0021B0 _H	MSGVAL21 [R] B,H,W 00000000 00000000		MSGVAL11 [R] B,H,W 00000000 00000000		
0021B4 _H	MSGVAL41 [R] B,H,W 00000000 00000000		MSGVAL31 [R] B,H,W 00000000 00000000		

MB91520 Series

Address	Address offset value / Register name				Block
	+0	+1	+2	+3	
0021B8 _H	—	—	—	—	CAN1 (64msb)
0021BC _H	—	—	—	—	
0021C0 _H to 0021FC _H	—				
002200 _H	CTRLR2 [R/W] B,H,W ----- 000-0001		STATR2 [R/W] B,H,W ----- 00000000		CAN2 (64msb)
002204 _H	ERRCNT2 [R] B,H,W 00000000 00000000		BTR2 [R/W] B,H,W -0100011 00000001		
002208 _H	INTR2 [R] B,H,W 00000000 00000000		TESTR2 [R/W] B,H,W ----- X00000--		
00220C _H	BRPER2 [R/W] B,H,W ----- ----0000		—		
002210 _H	IF1CREQ2 [R/W] B,H,W 0----- 00000001		IF1CMSK2 [R/W] B,H,W ----- 00000000		
002214 _H	IF1MSK22 [R/W] B,H,W 11-11111 11111111		IF1MSK12 [R/W] B,H,W 11111111 11111111		
002218 _H	IF1ARB22 [R/W] B,H,W 00000000 00000000		IF1ARB12 [R/W] B,H,W 00000000 00000000		
00221C _H	IF1MCTR2 [R/W] B,H,W 00000000 0---0000		—		
002220 _H	IF1DTA12 [R/W] B,H,W 00000000 00000000		IF1DTA22 [R/W] B,H,W 00000000 00000000		
002224 _H	IF1DTB12 [R/W] B,H,W 00000000 00000000		IF1DTB22 [R/W] B,H,W 00000000 00000000		
002228 _H	—	—	—	—	
00222C _H	—	—	—	—	
002230 _H , 002234 _H	Reserved (IF1 data mirror)				
002238 _H	—	—	—	—	
00223C _H	—	—	—	—	
002240 _H	IF2CREQ2 [R/W] B,H,W 0----- 00000001		IF2CMSK2 [R/W] B,H,W ----- 00000000		
002244 _H	IF2MSK22 [R/W] B,H,W 11-11111 11111111		IF2MSK12 [R/W] B,H,W 11111111 11111111		
002248 _H	IF2ARB22 [R/W] B,H,W 00000000 00000000		IF2ARB12 [R/W] B,H,W 00000000 00000000		
00224C _H	IF2MCTR2 [R/W] B,H,W 00000000 0---0000		—		
002250 _H	IF2DTA12 [R/W] B,H,W 00000000 00000000		IF2DTA22 [R/W] B,H,W 00000000 00000000		

MB91520 Series

Address	Address offset value / Register name				Block	
	+0	+1	+2	+3		
002254 _H	IF2DTB12 [R/W] B,H,W 00000000 00000000		IF2DTB22 [R/W] B,H,W 00000000 00000000		CAN2 (64msb)	
002258 _H	—	—	—	—		
00225C _H	—	—	—	—		
002260 _H , 002264 _H	Reserved (IF2 data mirror)					
002268 _H to 00227C _H	—					
002280 _H	TREQR22 [R] B,H,W 00000000 00000000		TREQR12 [R] B,H,W 00000000 00000000			
002284 _H	TREQR42 [R] B,H,W 00000000 00000000		TREQR32 [R] B,H,W 00000000 00000000			
002288 _H	—	—	—	—		
00228C _H	—	—	—	—		
002290 _H	NEWDT22 [R] B,H,W 00000000 00000000		NEWDT12 [R] B,H,W 00000000 00000000			
002294 _H	NEWDT42 [R] B,H,W 00000000 00000000		NEWDT32 [R] B,H,W 00000000 00000000			
002298 _H	—	—	—	—		
00229C _H	—	—	—	—		
0022A0 _H	INTPND22 [R] B,H,W 00000000 00000000		INTPND12 [R] B,H,W 00000000 00000000			
0022A4 _H	INTPND42 [R] B,H,W 00000000 00000000		INTPND32 [R] B,H,W 00000000 00000000			
0022A8 _H	—	—	—	—		
0022AC _H	—	—	—	—		
0022B0 _H	MSGVAL22 [R] B,H,W 00000000 00000000		MSGVAL12 [R] B,H,W 00000000 00000000			
0022B4 _H	MSGVAL42 [R] B,H,W 00000000 00000000		MSGVAL32 [R] B,H,W 00000000 00000000			
0022B8 _H	—	—	—	—		
0022BC _H	—	—	—	—		
0022C0 _H to 0022FC _H	—					
002300 _H	DFCTLR [R/W] B,H,W -0-----		—	DFSTR [R/W] B,H,W -----001		WorkFlash
002304 _H	—	—	—	—		

MB91520 Series

Address	Address offset value / Register name				Block
	+0	+1	+2	+3	
002308 _H	FLIFCTLR [R/W] B,H,W ---0-00	—	FLIFFER1 [R/W] B,H,W -----	FLIFFER2 [R/W] B,H,W -----	Flash / WorkFlash
00230C _H to 0023FC _H	—				Reserved
002400 _H	SEEARX [R] B,H,W -0000000 00000000		DEEARX [R] B,H,W -0000000 00000000		XBS RAM ECC control
002404 _H	EECSRX [R/W] B,H,W ----00--	—	EFEARX [R/W] B,H,W -0000000 00000000		
002408 _H	—	EFECRX [R/W] B,H,W -----0 00000000 00000000			
00240C _H to 0024FC _H	—				Reserved
003000 _H	SEEARA [R] B,H,W -----000 00000000		DEEARA [R] B,H,W -----000 00000000		Backup RAM ECC control
003004 _H	EECSRA [R/W] B,H,W ----00--	—	EFEARA [R/W] B,H,W -----000 00000000		
003008 _H	—	EFECRA [R/W] B,H,W -----0 00000000 00000000			
00300C _H	TEAR0X[R] B,H,W 000----- -0000000 00000000				RAM/ diagnosis XBS RAM
003010 _H	TEAR1X[R] B,H,W 000----- -0000000 00000000				
003014 _H	TEAR2X[R] B,H,W 000----- -0000000 00000000				
003018 _H	TAEARX [R/W] B,H,W -1111111 11111111		TASARX [R/W] B,H,W -0000000 00000000		
00301C _H	TFECRX [R/W] B,H,W ----0000	TICRX [R/W] B,H,W ----0000	TTCRX [R/W] B,H,W -----00 00001100		
003020 _H	TSRCRX [W] B,H,W 0-----	—	—	TKCCRX [R/W] B,H,W 00----00	
003024 _H to 00302C _H	—				
003030 _H	TEAR0A[R] B,H,W 000----- -000 00000000				RAM/ diagnosis Backup RAM
003034 _H	TEAR1A[R] B,H,W 000----- -000 00000000				
003038 _H	TEAR2A[R] B,H,W 000----- -000 00000000				
00303C _H	TAEARA[R/W] B,H,W -----111 11111111		TASARA[R/W] B,H,W -----000 00000000		

MB91520 Series

Address	Address offset value / Register name				Block
	+0	+1	+2	+3	
003040 _H	TFECRA [R/W] B,H,W ----0000	TICRA [R/W] B,H,W ----0000	TTCRA [R/W] B,H,W -----00 00001100		RAM/ diagnosis Backup RAM
003044 _H	TSRCRA [R/W] B,H,W 0-----	—	—	TKCCRA [R/W] B,H,W 00---00	
003048 _H to 0030FC _H	—				Reserved
003100 _H	BUSDIGSR0[R/W] H,W 00000000 0-----00		BUSDIGSR1[R/W] H,W 00000000 0-----00		BUS diagnosis
003104 _H	BUSDIGSR2[R/W] H,W 00000000 0-----00		BUSTSTR0[R/W] H,W 00--0000 00000000		
003108 _H	BUSADR0 [R] W 00000000 00000000 00000000 00000000				
00310C _H	BUSADR1 [R] W 00000000 00000000 00000000 00000000				
003110 _H	BUSADR2 [R] W 00000000 00000000 00000000 00000000				
003114 _H	—	—	BUSDIGSR3[R/W] H,W 00000000 0-----00		
003118 _H	BUSDIGSR4[R/W] H,W 00000000 0-----00		BUSTSTR1[R/W] H,W 00--000- 00000000		
00311C _H	—	—	—	—	
003120 _H	BUSADR3 [R] W 00000000 00000000 00000000 00000000				
003124 _H	BUSADR4 [R] W 00000000 00000000 00000000 00000000				
003128 _H to 003FFC _H	—				Reserved
004000 _H to 005FFC _H	Backup-RAM				Backup RAM area
006000 _H to 00EFC _H	—	—	—	—	Reserved
00F000 _H to 00FEFC _H	—	—	—	—	Reserved [S]
00FF00 _H	DSUCR [R/W] B,H,W -----0		—	—	OCDU [S]
00FF04 _H to 00FF0C _H	—				Reserved [S]
00FF10 _H	PCSR [R/W] B,H,W XXXXXXXX XXXXXXXX XXXXXXXX XXXXXXXX				OCDU [S]

Address	Address offset value / Register name				Block
	+0	+1	+2	+3	
00FF14 _H	PSSR [R/W] B,H,W XXXXXXXXXXXXXXXXXXXXXXXXXXXXXXXX				OCDU [S]
00FF18 _H to 00FF4 _H	—				Reserved [S]
00FFF8 _H	EDIR1 [R] B,H,W XXXXXXXXXXXXXXXXXXXXXXXXXXXXXXXX				OCDU [S]
00FFFC _H	EDIR0 [R] B,H,W XXXXXXXXXXXXXXXXXXXXXXXXXXXXXXXX				

[S]: It is a system register. The illegal instruction exception (data access error) is generated in these registers in the user mode when reading and writing to it.

MB91520 Series

■ INTERRUPT VECTOR TABLE

This list shows the assignments of interrupt factors and interrupt vectors/interrupt control registers.

● Interrupt vector

• 64pins

Interrupt factor	Interrupt number		Interrupt level	Offset	Default address for TBR	RN
	Decimal	Hexadecimal				
Reset	0	0	-	3FC _H	000FFFFC _H	-
System reserved	1	1	-	3F8 _H	000FFFF8 _H	-
System reserved	2	2	-	3F4 _H	000FFFF4 _H	-
System reserved	3	3	-	3F0 _H	000FFFF0 _H	-
System reserved	4	4	-	3EC _H	000FFFE _C	-
FPU exception	5	5	-	3E8 _H	000FFFE8 _H	-
Exception of instruction access protection violation	6	6	-	3E4 _H	000FFFE4 _H	-
Exception of data access protection violation	7	7	-	3E0 _H	000FFFE0 _H	-
Data access error interrupt	8	8	-	3DC _H	000FFFD _C	-
INTE instruction	9	9	-	3D8 _H	000FFFD8 _H	-
Instruction break	10	0A	-	3D4 _H	000FFFD4 _H	-
System reserved	11	0B	-	3D0 _H	000FFFD0 _H	-
System reserved	12	0C	-	3CC _H	000FFFC _C	-
System reserved	13	0D	-	3C8 _H	000FFFC8 _H	-
Exception of invalid instruction	14	0E	-	3C4 _H	000FFFC4 _H	-
NMI request	15	0F	15 (F _H) Fixed	3C0 _H	000FFFC0 _H	-
Error generation during internal bus diagnosis						
XBS RAM double-bit error generation						
Backup RAM double-bit error generation						
TPU violation						
External interrupt 0-7	16	10	ICR00	3BC _H	000FFFB _C	0
External interrupt 8-15	17	11	ICR01	3B8 _H	000FFFB8 _H	1* ⁸
External low-voltage detection interrupt						
Reload timer 0/1/4/5	18	12	ICR02	3B4 _H	000FFFB4 _H	2* ²
Reload timer 3/6/7	19	13	ICR03	3B0 _H	000FFFB0 _H	3* ²
Multi-function serial interface ch.0 (reception completed)	20	14	ICR04	3AC _H	000FFFAC _H	4* ¹
Multi-function serial interface ch.0 (status)						
Multi-function serial interface ch.0 (transmission completed)	21	15	ICR05	3A8 _H	000FFFA8 _H	5* ¹
-	22	16	ICR06	3A4 _H	000FFFA4 _H	-* ⁷
-	23	17	ICR07	3A0 _H	000FFFA0 _H	-* ⁷
-	24	18	ICR08	39C _H	000FFF9 _C	-* ⁷
-	25	19	ICR09	398 _H	000FFF98 _H	-* ⁷
Multi-function serial interface ch.3 (reception completed)	26	1A	ICR10	394 _H	000FFF94 _H	10* ¹
Multi-function serial interface ch.3 (status)						
Multi-function serial interface ch.3 (transmission completed)	27	1B	ICR11	390 _H	000FFF90 _H	11
Multi-function serial interface ch.4 (reception completed)	28	1C	ICR12	38C _H	000FFF8 _C	12* ¹
Multi-function serial interface ch.4 (status)						

MB91520 Series

Interrupt factor	Interrupt number		Interrupt level	Offset	Default address for TBR	RN
	Decimal	Hexadecimal				
Multi-function serial interface ch.4 (transmission completed)	29	1D	ICR13	388 _H	000FFF88 _H	13
Multi-function serial interface ch.5 (reception completed)	30	1E	ICR14	384 _H	000FFF84 _H	14* ¹
Multi-function serial interface ch.5 (status)						
Multi-function serial interface ch.5 (transmission completed)	31	1F	ICR15	380 _H	000FFF80 _H	15
Multi-function serial interface ch.6 (reception completed)	32	20	ICR16	37C _H	000FFF7C _H	16* ¹
Multi-function serial interface ch.6 (status)						
Multi-function serial interface ch.6 (transmission completed)	33	21	ICR17	378 _H	000FFF78 _H	17
CAN0	34	22	ICR18	374 _H	000FFF74 _H	-
CAN1	35	23	ICR19	370 _H	000FFF70 _H	-
RAM diagnosis end						
RAM initialization completion						
Error generation during RAM diagnosis						
Backup RAM diagnosis end						
Backup RAM initialization completion						
Error generation during Backup RAM diagnosis						
CAN2	36	24	ICR20	36C _H	000FFF6C _H	-
Up/down counter 0						
Up/down counter 1						
Real time clock	37	25	ICR21	368 _H	000FFF68 _H	-
-	38	26	ICR22	364 _H	000FFF64 _H	-* ⁷
16-bit Free-run timer 0 (0 detection) / (compare clear)	39	27	ICR23	360 _H	000FFF60 _H	23
PPG 1/10/11/20/30/31	40	28	ICR24	35C _H	000FFF5C _H	24* ³
16-bit Free-run timer 1 (0 detection) / (compare clear)						
PPG 2/3/12/13/23/43	41	29	ICR25	358 _H	000FFF58 _H	25* ³
16-bit Free-run timer 2 (0 detection) / (compare clear)						
PPG 4/24/35	42	2A	ICR26	354 _H	000FFF54 _H	26* ³
PPG 7/16/17/27/37	43	2B	ICR27	350 _H	000FFF50 _H	27* ³
PPG 19	44	2C	ICR28	34C _H	000FFF4C _H	28* ³
16-bit ICU 0 (fetching) / 16-bit ICU 1 (fetching)	45	2D	ICR29	348 _H	000FFF48 _H	29
Main timer	46	2E	ICR30	344 _H	000FFF44 _H	30
Sub timer						
PLL timer						
16-bit ICU 2 (fetching) / 16-bit ICU 3 (fetching)						
Clock calibration unit (sub oscillation)	47	2F	ICR31	340 _H	000FFF40 _H	31* ^{1,*4}
Multi-function serial interface ch.9 (reception completed)						
Multi-function serial interface ch.9 (status)						
A/D converter 0/1/7/10/11/14/15/16/17/22/27/28/31	48	30	ICR32	33C _H	000FFF3C _H	32

MB91520 Series

Interrupt factor	Interrupt number		Interrupt level	Offset	Default address for TBR	RN
	Decimal	Hexadecimal				
Clock calibration unit (CR oscillation)	49	31	ICR33	338 _H	000FFF38 _H	33
Multi-function serial interface ch.9 (transmission completed)						
16-bit OCU 0 (match) / 16-bit OCU 1 (match)						
32-bit Free-run timer 4	50	32	ICR34	334 _H	000FFF34 _H	34* ⁶
16-bit OCU 2 (match) / 16-bit OCU 3 (match)						
16-bit OCU 4 (match) / 16-bit OCU 5 (match)						
32-bit ICU6 (fetching/measurement)	51	33	ICR35	330 _H	000FFF30 _H	35
Multi-function serial interface ch.10 (reception completed)						
Multi-function serial interface ch.10 (status)						
Multi-function serial interface ch.10 (transmission completed)	52	34	ICR36	32C _H	000FFF2C _H	36* ¹
32-bit ICU8 (fetching/measurement)						
Multi-function serial interface ch.11 (reception completed)						
Multi-function serial interface ch.11 (status)	53	35	ICR37	328 _H	000FFF28 _H	37
32-bit ICU9 (fetching/measurement)						
Multi-function serial interface ch.11 (transmission completed)						
Multi-function serial interface ch.11 (status)	54	36	ICR38	324 _H	000FFF24 _H	38* ¹
32-bit ICU9 (fetching/measurement)						
WG dead timer underflow 0 / 1 / 2						
WG dead timer reload 0 / 1 / 2	55	37	ICR39	320 _H	000FFF20 _H	39
WG DTTI 0						
32-bit ICU4 (fetching/measurement)						
Multi-function serial interface ch.11 (transmission completed)	56	38	ICR40	31C _H	000FFF1C _H	40
32-bit ICU5 (fetching/measurement)						
A/D converter 32/34/35/37/38/40/41/42/43/44/45/46/47						
32-bit OCU7/11 (match)	57	39	ICR41	318 _H	000FFF18 _H	41
32-bit OCU8/9 (match)						
-						
-	60	3C	ICR44	30C _H	000FFF0C _H	-* ⁷
-						
-						
DMAC0/1/2/3/4/5/6/7/8/9/10/11/12/13/14/15	61	3D	ICR45	308 _H	000FFF08 _H	-
Delay interrupt						
System reserved (Used for REALOS™* ⁹)						
System reserved (Used for REALOS)	62	3E	ICR46	304 _H	000FFF04 _H	-
System reserved (Used for REALOS)						
System reserved (Used for REALOS)						
System reserved (Used for REALOS)	63	3F	ICR47	300 _H	000FFF00 _H	-
System reserved (Used for REALOS)						
System reserved (Used for REALOS)						
System reserved (Used for REALOS)	64	40	-	2FC _H	000FFEFC _H	-
System reserved (Used for REALOS)						
System reserved (Used for REALOS)						
System reserved (Used for REALOS)	65	41	-	2F8 _H	000FFE8 _H	-
System reserved (Used for REALOS)						
System reserved (Used for REALOS)						
System reserved (Used for REALOS)	66	42	-	2F4 _H	000FFE4 _H	-
System reserved (Used for REALOS)						
System reserved (Used for REALOS)						
Used with the INT instruction	66 255	42 FF	-	2F4 _H 000 _H	000FFE4 _H 000FFC00 _H	-

Note: It does not support a DMA transfer request caused by an interrupt generated from a peripheral to which no RN (Resource Number) is assigned.

*1: It does not support a DMA transfer by the status of the multi-function serial interface and I²C reception.

*2: Reload timer ch.4 to ch.7 do not support a DMA transfer by the interrupt.

*3: PPG ch.24 to ch.47 do not support a DMA transfer by the interrupt.

*4: The clock calibration unit does not support a DMA transfer by the interrupt.

*5: It does not support a DMA transfer by the interrupt by the RAM ECC bit error.

*6: 32-bit Free-run timer ch.3, ch.4 and ch.5 do not support a DMA transfer by the interrupt.

*7: There is no resource corresponding to the interrupt level.

*8: It does not support a DMA transfer by the external low-voltage detection interrupt.

*9: REALOS is a trademark of Fujitsu Semiconductor Limited, Japan.

MB91520 Series

• 80pins

Interrupt factor	Interrupt number		Interrupt level	Offset	Default address for TBR	RN
	Decimal	Hexadecimal				
Reset	0	0	-	3FC _H	000FFFFC _H	-
System reserved	1	1	-	3F8 _H	000FFFF8 _H	-
System reserved	2	2	-	3F4 _H	000FFFF4 _H	-
System reserved	3	3	-	3F0 _H	000FFFF0 _H	-
System reserved	4	4	-	3EC _H	000FFFE _C	-
FPU exception	5	5	-	3E8 _H	000FFFE8 _H	-
Exception of instruction access protection violation	6	6	-	3E4 _H	000FFFE4 _H	-
Exception of data access protection violation	7	7	-	3E0 _H	000FFFE0 _H	-
Data access error interrupt	8	8	-	3DC _H	000FFFD _C	-
INTE instruction	9	9	-	3D8 _H	000FFFD8 _H	-
Instruction break	10	0A	-	3D4 _H	000FFFD4 _H	-
System reserved	11	0B	-	3D0 _H	000FFFD0 _H	-
System reserved	12	0C	-	3CC _H	000FFFCC _H	-
System reserved	13	0D	-	3C8 _H	000FFF8 _C	-
Exception of invalid instruction	14	0E	-	3C4 _H	000FFF4 _C	-
NMI request	15	0F	15 (F _H) Fixed	3C0 _H	000FFF0 _C	-
Error generation during internal bus diagnosis						
XBS RAM double-bit error generation						
Backup RAM double-bit error generation						
TPU violation						
External interrupt 0-7	16	10	ICR00	3BC _H	000FFFBC _H	0
External interrupt 8-15	17	11	ICR01	3B8 _H	000FFF8 _B	1* ⁸
External low-voltage detection interrupt						
Reload timer 0/1/4/5	18	12	ICR02	3B4 _H	000FFF4 _B	2* ²
Reload timer 3/6/7	19	13	ICR03	3B0 _H	000FFF0 _B	3* ²
Multi-function serial interface ch.0 (reception completed)	20	14	ICR04	3AC _H	000FFFAC _H	4* ¹
Multi-function serial interface ch.0 (status)						
Multi-function serial interface ch.0 (transmission completed)	21	15	ICR05	3A8 _H	000FFFA8 _H	5* ¹
-	22	16	ICR06	3A4 _H	000FFFA4 _H	-* ⁷
-	23	17	ICR07	3A0 _H	000FFFA0 _H	-* ⁷
Multi-function serial interface ch.2 (reception completed)	24	18	ICR08	39C _H	000FFF9C _H	8* ¹
Multi-function serial interface ch.2 (status)						
Multi-function serial interface ch.2 (transmission completed)	25	19	ICR09	398 _H	000FFF98 _H	9* ¹
Multi-function serial interface ch.3 (reception completed)	26	1A	ICR10	394 _H	000FFF94 _H	10* ¹
Multi-function serial interface ch.3 (status)						
Multi-function serial interface ch.3 (transmission completed)	27	1B	ICR11	390 _H	000FFF90 _H	11
Multi-function serial interface ch.4 (reception completed)	28	1C	ICR12	38C _H	000FFF8C _H	12* ¹
Multi-function serial interface ch.4 (status)						

MB91520 Series

Interrupt factor	Interrupt number		Interrupt level	Offset	Default address for TBR	RN
	Decimal	Hexadecimal				
Multi-function serial interface ch.4 (transmission completed)	29	1D	ICR13	388 _H	000FFF88 _H	13
Multi-function serial interface ch.5 (reception completed)	30	1E	ICR14	384 _H	000FFF84 _H	14* ¹
Multi-function serial interface ch.5 (status)						
Multi-function serial interface ch.5 (transmission completed)	31	1F	ICR15	380 _H	000FFF80 _H	15
Multi-function serial interface ch.6 (reception completed)	32	20	ICR16	37C _H	000FFF7C _H	16* ¹
Multi-function serial interface ch.6 (status)						
Multi-function serial interface ch.6 (transmission completed)	33	21	ICR17	378 _H	000FFF78 _H	17
CAN0	34	22	ICR18	374 _H	000FFF74 _H	-
CAN1	35	23	ICR19	370 _H	000FFF70 _H	-
RAM diagnosis end						
RAM initialization completion						
Error generation during RAM diagnosis						
Backup RAM diagnosis end						
Backup RAM initialization completion						
Error generation during Backup RAM diagnosis						
CAN2	36	24	ICR20	36C _H	000FFF6C _H	-
Up/down counter 0						
Up/down counter 1						
Real time clock	37	25	ICR21	368 _H	000FFF68 _H	-
-	38	26	ICR22	364 _H	000FFF64 _H	-* ⁷
16-bit Free-run timer 0 (0 detection) / (compare clear)	39	27	ICR23	360 _H	000FFF60 _H	23
PPG 1/10/11/20/30/31	40	28	ICR24	35C _H	000FFF5C _H	24* ³
16-bit Free-run timer 1 (0 detection) / (compare clear)						
PPG 2/3/12/13/23/43	41	29	ICR25	358 _H	000FFF58 _H	25* ³
16-bit Free-run timer 2 (0 detection) / (compare clear)						
PPG 4/5/15/24/35	42	2A	ICR26	354 _H	000FFF54 _H	26* ³
PPG 7/16/17/26/27/37	43	2B	ICR27	350 _H	000FFF50 _H	27* ³
PPG 8/18/19/29	44	2C	ICR28	34C _H	000FFF4C _H	28* ³
16-bit ICU 0 (fetching) / 16-bit ICU 1 (fetching)	45	2D	ICR29	348 _H	000FFF48 _H	29
Main timer	46	2E	ICR30	344 _H	000FFF44 _H	30
Sub timer						
PLL timer						
16-bit ICU 2 (fetching) / 16-bit ICU 3 (fetching)						
Clock calibration unit (sub oscillation)	47	2F	ICR31	340 _H	000FFF40 _H	31* ^{1,*4}
Multi-function serial interface ch.9 (reception completed)						
Multi-function serial interface ch.9 (status)						

MB91520 Series

Interrupt factor	Interrupt number		Interrupt level	Offset	Default address for TBR	RN
	Decimal	Hexadecimal				
A/D converter 0/1/7/10/11/12/14/15/16/17/19/22/26/27/28/31	48	30	ICR32	33C _H	000FFF3C _H	32
Clock calibration unit (CR oscillation)	49	31	ICR33	338 _H	000FFF38 _H	33
Multi-function serial interface ch.9 (transmission completed)						
16-bit OCU 0 (match) / 16-bit OCU 1 (match)	50	32	ICR34	334 _H	000FFF34 _H	34* ⁶
32-bit Free-run timer 4						
16-bit OCU 2 (match) / 16-bit OCU 3 (match)	51	33	ICR35	330 _H	000FFF30 _H	35* ⁶
32-bit Free-run timer 5						
16-bit OCU 4 (match) / 16-bit OCU 5 (match)	52	34	ICR36	32C _H	000FFF2C _H	36* ¹
32-bit ICU6 (fetching/measurement)						
Multi-function serial interface ch.10 (reception completed)						
Multi-function serial interface ch.10 (status)	53	35	ICR37	328 _H	000FFF28 _H	37
Multi-function serial interface ch.10 (transmission completed)						
32-bit ICU8 (fetching/measurement)	54	36	ICR38	324 _H	000FFF24 _H	38* ¹
Multi-function serial interface ch.11 (reception completed)						
Multi-function serial interface ch.11 (status)						
32-bit ICU9 (fetching/measurement)	55	37	ICR39	320 _H	000FFF20 _H	39
WG dead timer underflow 0 / 1 / 2						
WG dead timer reload 0 / 1 / 2						
WG DTI 0						
32-bit ICU4 (fetching/measurement)	56	38	ICR40	31C _H	000FFF1C _H	40
Multi-function serial interface ch.11 (transmission completed)						
32-bit ICU5 (fetching/measurement)						
A/D converter 32/33/34/35/36/37/38/39/40/41/42/43/44/45/46/47	57	39	ICR41	318 _H	000FFF18 _H	41
32-bit OCU7/11 (match)						
32-bit OCU8/9 (match)	58	3A	ICR42	314 _H	000FFF14 _H	42
-	59	3B	ICR43	310 _H	000FFF10 _H	43
-	60	3C	ICR44	30C _H	000FFF0C _H	-* ⁷
Base timer 1 IRQ0	61	3D	ICR45	308 _H	000FFF08 _H	45* ⁵
Base timer 1 IRQ1						
-						
-	62	3E	ICR46	304 _H	000FFF04 _H	-
DMAC 0/1/2/3/4/5/6/7/8/9/10/11/12/13/14/15						
Delay interrupt	63	3F	ICR47	300 _H	000FFF00 _H	-
System reserved (Used for REALOS)	64	40	-	2FC _H	000FFEFC _H	-
System reserved (Used for REALOS)	65	41	-	2F8 _H	000FFE8 _H	-
Used with the INT instruction	66	42	-	2F4 _H	000FFE4 _H	-
	255	FF	-	000 _H	000FFC00 _H	-

Note: It does not support a DMA transfer request caused by an interrupt generated from a peripheral to which no RN (Resource Number) is assigned.

*1: It does not support a DMA transfer by the status of the multi-function serial interface and I²C reception.

*2: Reload timer ch.4 to ch.7 do not support a DMA transfer by the interrupt.

- *3: PPG ch.24 to ch.47 do not support a DMA transfer by the interrupt.
- *4: The clock calibration unit does not support a DMA transfer by the interrupt.
- *5: It does not support a DMA transfer by the interrupt by the RAM ECC bit error.
- *6: 32-bit Free-run timer ch.3, ch.4 and ch.5 do not support a DMA transfer by the interrupt.
- *7: There is no resource corresponding to the interrupt level.
- *8: It does not support a DMA transfer by the external low-voltage detection interrupt.

MB91520 Series

• 100pins

Interrupt factor	Interrupt number		Interrupt level	Offset	Default address for TBR	RN
	Decimal	Hexadecimal				
Reset	0	0	-	3FC _H	000FFFFC _H	-
System reserved	1	1	-	3F8 _H	000FFFF8 _H	-
System reserved	2	2	-	3F4 _H	000FFFF4 _H	-
System reserved	3	3	-	3F0 _H	000FFFF0 _H	-
System reserved	4	4	-	3EC _H	000FFFE _C	-
FPU exception	5	5	-	3E8 _H	000FFFE8 _H	-
Exception of instruction access protection violation	6	6	-	3E4 _H	000FFFE4 _H	-
Exception of data access protection violation	7	7	-	3E0 _H	000FFFE0 _H	-
Data access error interrupt	8	8	-	3DC _H	000FFFD _C	-
INTE instruction	9	9	-	3D8 _H	000FFFD8 _H	-
Instruction break	10	0A	-	3D4 _H	000FFFD4 _H	-
System reserved	11	0B	-	3D0 _H	000FFFD0 _H	-
System reserved	12	0C	-	3CC _H	000FFFC _C	-
System reserved	13	0D	-	3C8 _H	000FFFC8 _H	-
Exception of invalid instruction	14	0E	-	3C4 _H	000FFFC4 _H	-
NMI request	15	0F	15 (F _H) Fixed	3C0 _H	000FFFC0 _H	-
Error generation during internal bus diagnosis						
XBS RAM double-bit error generation						
Backup RAM double-bit error generation						
TPU violation						
External interrupt 0-7	16	10	ICR00	3BC _H	000FFFB _C	0
External interrupt 8-15	17	11	ICR01	3B8 _H	000FFFB8 _H	1* ⁸
External low-voltage detection interrupt						
Reload timer 0/1/4/5	18	12	ICR02	3B4 _H	000FFFB4 _H	2* ²
Reload timer 2/3/6/7	19	13	ICR03	3B0 _H	000FFFB0 _H	3* ²
Multi-function serial interface ch.0 (reception completed)	20	14	ICR04	3AC _H	000FFFAC _H	4* ¹
Multi-function serial interface ch.0 (status)						
Multi-function serial interface ch.0 (transmission completed)	21	15	ICR05	3A8 _H	000FFFA8 _H	5* ¹
Multi-function serial interface ch.1 (reception completed)	22	16	ICR06	3A4 _H	000FFFA4 _H	6* ¹
Multi-function serial interface ch.1 (status)						
Multi-function serial interface ch.1 (transmission completed)	23	17	ICR07	3A0 _H	000FFFA0 _H	7* ¹
Multi-function serial interface ch.2 (reception completed)	24	18	ICR08	39C _H	000FFF9C _H	8* ¹
Multi-function serial interface ch.2 (status)						
Multi-function serial interface ch.2 (transmission completed)	25	19	ICR09	398 _H	000FFF98 _H	9* ¹
Multi-function serial interface ch.3 (reception completed)	26	1A	ICR10	394 _H	000FFF94 _H	10* ¹
Multi-function serial interface ch.3 (status)						
Multi-function serial interface ch.3 (transmission completed)	27	1B	ICR11	390 _H	000FFF90 _H	11

MB91520 Series

Interrupt factor	Interrupt number		Interrupt level	Offset	Default address for TBR	RN
	Decimal	Hexadecimal				
Multi-function serial interface ch.4 (reception completed)	28	1C	ICR12	38C _H	000FFF8C _H	12* ¹
Multi-function serial interface ch.4 (status)						
Multi-function serial interface ch.4 (transmission completed)	29	1D	ICR13	388 _H	000FFF88 _H	13
Multi-function serial interface ch.5 (reception completed)	30	1E	ICR14	384 _H	000FFF84 _H	14* ¹
Multi-function serial interface ch.5 (status)						
Multi-function serial interface ch.5 (transmission completed)	31	1F	ICR15	380 _H	000FFF80 _H	15
Multi-function serial interface ch.6 (reception completed)	32	20	ICR16	37C _H	000FFF7C _H	16* ¹
Multi-function serial interface ch.6 (status)						
Multi-function serial interface ch.6 (transmission completed)	33	21	ICR17	378 _H	000FFF78 _H	17
CAN0	34	22	ICR18	374 _H	000FFF74 _H	-
CAN1	35	23	ICR19	370 _H	000FFF70 _H	-
RAM diagnosis end						
RAM initialization completion						
Error generation during RAM diagnosis						
Backup RAM diagnosis end						
Backup RAM initialization completion						
Error generation during Backup RAM diagnosis						
CAN2	36	24	ICR20	36C _H	000FFF6C _H	-
Up/down counter 0						
Up/down counter 1						
Real time clock	37	25	ICR21	368 _H	000FFF68 _H	-
Multi-function serial interface ch.7 (reception completed)	38	26	ICR22	364 _H	000FFF64 _H	22* ¹
Multi-function serial interface ch.7 (status)						
16-bit Free-running timer 0 (0 detection) / (compare clear)	39	27	ICR23	360 _H	000FFF60 _H	23
Multi-function serial interface ch.7 (transmission completed)						
PPG 1/10/11/20/21/30/31	40	28	ICR24	35C _H	000FFF5C _H	24* ³
16-bit Free-run timer 1 (0 detection) / (compare clear)						
PPG 2/3/12/13/23/32/43	41	29	ICR25	358 _H	000FFF58 _H	25* ³
16-bit Free-run timer 2 (0 detection) / (compare clear)						
PPG 4/5/14/15/24/25/35/44	42	2A	ICR26	354 _H	000FFF54 _H	26* ³
PPG 6/7/16/17/26/27/37	43	2B	ICR27	350 _H	000FFF50 _H	27* ³
PPG 8/9/18/19/28/29	44	2C	ICR28	34C _H	000FFF4C _H	28* ³
Multi-function serial interface ch.8 (reception completed)	45	2D	ICR29	348 _H	000FFF48 _H	29* ¹
Multi-function serial interface ch.8 (status)						
16-bit ICU 0 (fetching) / 16-bit ICU 1 (fetching)						

MB91520 Series

Interrupt factor	Interrupt number		Interrupt level	Offset	Default address for TBR	RN
	Decimal	Hexadecimal				
Main timer	46	2E	ICR30	344 _H	000FFF44 _H	30
Sub timer						
PLL timer						
Multi-function serial interface ch.8 (transmission completed)						
16-bit ICU 2 (fetching) / 16-bit ICU 3 (fetching)	47	2F	ICR31	340 _H	000FFF40 _H	31* ¹ , * ₄
Clock calibration unit (sub oscillation)						
Multi-function serial interface ch.9 (reception completed)						
Multi-function serial interface ch.9 (status)						
A/D converter 0/1/7/9/10/11/12/13/14/15/16 17/18/19/22/23/26/27/28/29/31	48	30	ICR32	33C _H	000FFF3C _H	32
Clock calibration unit (CR oscillation)	49	31	ICR33	338 _H	000FFF38 _H	33
Multi-function serial interface ch.9 (transmission completed)						
16-bit OCU 0 (match) / 16-bit OCU 1 (match)						
32-bit Free-run timer 4	50	32	ICR34	334 _H	000FFF34 _H	34* ⁶
16-bit OCU 2 (match) / 16-bit OCU 3 (match)						
32-bit Free-run timer 3/5	51	33	ICR35	330 _H	000FFF30 _H	35* ⁶
16-bit OCU 4 (match) / 16-bit OCU 5 (match)						
32-bit ICU6 (fetching/measurement)	52	34	ICR36	32C _H	000FFF2C _H	36* ¹
Multi-function serial interface ch.10 (reception completed)						
Multi-function serial interface ch.10 (status)						
32-bit ICU7 (fetching/measurement)	53	35	ICR37	328 _H	000FFF28 _H	37
Multi-function serial interface ch.10 (transmission completed)						
32-bit ICU8 (fetching/measurement)	54	36	ICR38	324 _H	000FFF24 _H	38* ¹
Multi-function serial interface ch.11 (reception completed)						
Multi-function serial interface ch.11 (status)						
32-bit ICU9 (fetching/measurement)	55	37	ICR39	320 _H	000FFF20 _H	39
WG dead timer underflow 0/1/2						
WG dead timer reload 0/1/2						
WG DTTI 0	56	38	ICR40	31C _H	000FFF1C _H	40
32-bit ICU4 (fetching/measurement)						
Multi-function serial interface ch.11 (transmission completed)	57	39	ICR41	318 _H	000FFF18 _H	41
32-bit ICU5 (fetching/measurement)						
A/D converter 32/33/34/35/36/37/38/39/40/41/42/43/44/45/46/ 47	58	3A	ICR42	314 _H	000FFF14 _H	42
32-bit OCU 6/7/10/11 (match)						
32-bit OCU 8/9 (match)	59	3B	ICR43	310 _H	000FFF10 _H	43
Base timer 0 IRQ0	60	3C	ICR44	30C _H	000FFF0C _H	44
Base timer 0 IRQ1						

Interrupt factor	Interrupt number		Interrupt level	Offset	Default address for TBR	RN
	Decimal	Hexadecimal				
Base timer 1 IRQ0	61	3D	ICR45	308 _H	000FFF08 _H	45* ⁵
Base timer 1 IRQ1						
-						
-						
DMAC 0/1/2/3/4/5/6/7/8/9/10/11/12/13/14/15	62	3E	ICR46	304 _H	000FFF04 _H	-
Delay interrupt	63	3F	ICR47	300 _H	000FFF00 _H	-
System reserved (Used for REALOS)	64	40	-	2FC _H	000FFEFC _H	-
System reserved (Used for REALOS)	65	41	-	2F8 _H	000FEF8 _H	-
Used with the INT instruction	66	42	-	2F4 _H	000FEF4 _H	-
	 255	 FF		 000 _H	 000FFC00 _H	

Note: It does not support a DMA transfer request caused by an interrupt generated from a peripheral to which no RN (Resource Number) is assigned.

- *1: It does not support a DMA transfer by the status of the multi-function serial interface and I²C reception.
- *2: Reload timer ch.4 to ch.7 do not support a DMA transfer by the interrupt.
- *3: PPG ch.24 to ch.47 do not support a DMA transfer by the interrupt.
- *4: The clock calibration unit does not support a DMA transfer by the interrupt.
- *5: It does not support a DMA transfer by the interrupt by the RAM ECC bit error.
- *6: 32-bit Free-run timer ch.3, ch.4 and ch.5 do not support a DMA transfer by the interrupt.
- *7: There is no resource corresponding to the interrupt level.
- *8: It does not support a DMA transfer by the external low-voltage detection interrupt.

MB91520 Series

• 120pins

Interrupt factor	Interrupt number		Interrupt level	Offset	Default address for TBR	RN
	Decimal	Hexadecimal				
Reset	0	0	-	3FC _H	000FFFFC _H	-
System reserved	1	1	-	3F8 _H	000FFFF8 _H	-
System reserved	2	2	-	3F4 _H	000FFFF4 _H	-
System reserved	3	3	-	3F0 _H	000FFFF0 _H	-
System reserved	4	4	-	3EC _H	000FFFE _C	-
FPU exception	5	5	-	3E8 _H	000FFFE8 _H	-
Exception of instruction access protection violation	6	6	-	3E4 _H	000FFFE4 _H	-
Exception of data access protection violation	7	7	-	3E0 _H	000FFFE0 _H	-
Data access error interrupt	8	8	-	3DC _H	000FFFD _C	-
INTE instruction	9	9	-	3D8 _H	000FFFD8 _H	-
Instruction break	10	0A	-	3D4 _H	000FFFD4 _H	-
System reserved	11	0B	-	3D0 _H	000FFFD0 _H	-
System reserved	12	0C	-	3CC _H	000FFFC _C	-
System reserved	13	0D	-	3C8 _H	000FFFC8 _H	-
Exception of invalid instruction	14	0E	-	3C4 _H	000FFFC4 _H	-
NMI request	15	0F	15 (F _H) Fixed	3C0 _H	000FFFC0 _H	-
Error generation during internal bus diagnosis						
XBS RAM double-bit error generation						
Backup RAM double-bit error generation						
TPU violation						
External interrupt 0-7	16	10	ICR00	3BC _H	000FFFBC _H	0
External interrupt 8-15	17	11	ICR01	3B8 _H	000FFFB8 _H	1* ⁸
External low-voltage detection interrupt						
Reload timer 0/1/4/5	18	12	ICR02	3B4 _H	000FFFB4 _H	2* ²
Reload timer 2/3/6/7	19	13	ICR03	3B0 _H	000FFFB0 _H	3* ²
Multi-function serial interface ch.0 (reception completed)	20	14	ICR04	3AC _H	000FFFAC _H	4* ¹
Multi-function serial interface ch.0 (status)						
Multi-function serial interface ch.0 (transmission completed)	21	15	ICR05	3A8 _H	000FFFA8 _H	5* ¹
Multi-function serial interface ch.1 (reception completed)	22	16	ICR06	3A4 _H	000FFFA4 _H	6* ¹
Multi-function serial interface ch.1 (status)						
Multi-function serial interface ch.1 (transmission completed)	23	17	ICR07	3A0 _H	000FFFA0 _H	7* ¹
Multi-function serial interface ch.2 (reception completed)	24	18	ICR08	39C _H	000FFF9C _H	8* ¹
Multi-function serial interface ch.2 (status)						
Multi-function serial interface ch.2 (transmission completed)	25	19	ICR09	398 _H	000FFF98 _H	9* ¹
Multi-function serial interface ch.3 (reception completed)	26	1A	ICR10	394 _H	000FFF94 _H	10* ¹
Multi-function serial interface ch.3 (status)						
Multi-function serial interface ch.3 (transmission completed)	27	1B	ICR11	390 _H	000FFF90 _H	11

MB91520 Series

Interrupt factor	Interrupt number		Interrupt level	Offset	Default address for TBR	RN
	Decimal	Hexadecimal				
Multi-function serial interface ch.4 (reception completed)	28	1C	ICR12	38C _H	000FFF8C _H	12* ¹
Multi-function serial interface ch.4 (status)						
Multi-function serial interface ch.4 (transmission completed)	29	1D	ICR13	388 _H	000FFF88 _H	13
Multi-function serial interface ch.5 (reception completed)	30	1E	ICR14	384 _H	000FFF84 _H	14* ¹
Multi-function serial interface ch.5 (status)						
Multi-function serial interface ch.5 (transmission completed)	31	1F	ICR15	380 _H	000FFF80 _H	15
Multi-function serial interface ch.6 (reception completed)	32	20	ICR16	37C _H	000FFF7C _H	16* ¹
Multi-function serial interface ch.6 (status)						
Multi-function serial interface ch.6 (transmission completed)	33	21	ICR17	378 _H	000FFF78 _H	17
CAN0	34	22	ICR18	374 _H	000FFF74 _H	-
CAN1	35	23	ICR19	370 _H	000FFF70 _H	-
RAM diagnosis end						
RAM initialization completion						
Error generation during RAM diagnosis						
Backup RAM diagnosis end						
Backup RAM initialization completion						
Error generation during Backup RAM diagnosis						
CAN2	36	24	ICR20	36C _H	000FFF6C _H	-
Up/down counter 0						
Up/down counter 1						
Real time clock	37	25	ICR21	368 _H	000FFF68 _H	-
Multi-function serial interface ch.7 (reception completed)	38	26	ICR22	364 _H	000FFF64 _H	22* ¹
Multi-function serial interface ch.7 (status)						
16-bit Free-run timer 0 (0 detection) / (compare clear)	39	27	ICR23	360 _H	000FFF60 _H	23
Multi-function serial interface ch.7 (transmission completed)						
PPG 0/1/10/11/20/21/30/31	40	28	ICR24	35C _H	000FFF5C _H	24* ³
16-bit Free-run timer 1 (0 detection) / (compare clear)						
PPG 2/3/12/13/22/23/32/33/42/43	41	29	ICR25	358 _H	000FFF58 _H	25* ³
16-bit Free-run timer 2 (0 detection) / (compare clear)						
PPG 4/5/14/15/24/25/35/44	42	2A	ICR26	354 _H	000FFF54 _H	26* ³
PPG 6/7/16/17/26/27/37	43	2B	ICR27	350 _H	000FFF50 _H	27* ³
PPG 8/9/18/19/28/29	44	2C	ICR28	34C _H	000FFF4C _H	28* ³
Multi-function serial interface ch.8 (reception completed)	45	2D	ICR29	348 _H	000FFF48 _H	29* ¹
Multi-function serial interface ch.8 (status)						
16-bit ICU 0 (fetching) / 16-bit ICU 1 (fetching)						

MB91520 Series

Interrupt factor	Interrupt number		Interrupt level	Offset	Default address for TBR	RN
	Decimal	Hexadecimal				
Main timer	46	2E	ICR30	344 _H	000FFF44 _H	30
Sub timer						
PLL timer						
Multi-function serial interface ch.8 (transmission completed)						
16-bit ICU 2 (fetching) / 16-bit ICU 3 (fetching)	47	2F	ICR31	340 _H	000FFF40 _H	31* ¹ , * ₄
Clock calibration unit (sub oscillation)						
Multi-function serial interface ch.9 (reception completed)						
Multi-function serial interface ch.9 (status)						
A/D converter 0/1/7/9/10/11/12/13/14/15/16/ 17/18/19/20/21/22/23/24/25/26/27/28/29/30/31	48	30	ICR32	33C _H	000FFF3C _H	32
Clock calibration unit (CR oscillation)						
Multi-function serial interface ch.9 (transmission completed)	49	31	ICR33	338 _H	000FFF38 _H	33
16-bit OCU 0 (match) / 16-bit OCU 1 (match)						
32-bit Free-run timer 4						
16-bit OCU 2 (match) / 16-bit OCU 3 (match)	50	32	ICR34	334 _H	000FFF34 _H	34* ⁶
32-bit Free-run timer 3/5						
16-bit OCU 4 (match) / 16-bit OCU 5 (match)	51	33	ICR35	330 _H	000FFF30 _H	35* ⁶
32-bit ICU6 (fetching/measurement)						
Multi-function serial interface ch.10 (reception completed)	52	34	ICR36	32C _H	000FFF2C _H	36* ¹
Multi-function serial interface ch.10 (status)						
32-bit ICU7 (fetching/measurement)	53	35	ICR37	328 _H	000FFF28 _H	37
Multi-function serial interface ch.10 (transmission completed)						
32-bit ICU8 (fetching/measurement)	54	36	ICR38	324 _H	000FFF24 _H	38* ¹
Multi-function serial interface ch.11 (reception completed)						
Multi-function serial interface ch.11 (status)						
32-bit ICU9 (fetching/measurement)	55	37	ICR39	320 _H	000FFF20 _H	39
WG dead timer underflow 0/1/2						
WG dead timer reload 0/1/2						
WG DTTI 0						
32-bit ICU4 (fetching/measurement)	56	38	ICR40	31C _H	000FFF1C _H	40
Multi-function serial interface ch.11 (transmission completed)						
32-bit ICU5 (fetching/measurement)	57	39	ICR41	318 _H	000FFF18 _H	41
A/D converter 32/33/34/35/36/37/38/39/40/41/42/43/44/45/46/47						
32-bit OCU 6/7/10/11 (match)	58	3A	ICR42	314 _H	000FFF14 _H	42
32-bit OCU 8/9 (match)	59	3B	ICR43	310 _H	000FFF10 _H	43
Base timer 0 IRQ0	60	3C	ICR44	30C _H	000FFF0C _H	44
Base timer 0 IRQ1						
Base timer 1 IRQ0						
Base timer 1 IRQ1						
-	61	3D	ICR45	308 _H	000FFF08 _H	45* ⁵
-						

Interrupt factor	Interrupt number		Interrupt level	Offset	Default address for TBR	RN
	Decimal	Hexadecimal				
DMAC0/1/2/3/4/5/6/7/8/9/10/11/12/13/14/15	62	3E	ICR46	304 _H	000FFF04 _H	-
Delay interrupt	63	3F	ICR47	300 _H	000FFF00 _H	-
System reserved (Used for REALOS)	64	40	-	2FC _H	000FFEFC _H	-
System reserved (Used for REALOS)	65	41	-	2F8 _H	000FFE8 _H	-
Used with the INT instruction	66	42	-	2F4 _H	000FFE4 _H	-
	 255	 FF		 000 _H	 000FFC00 _H	

Note: It does not support a DMA transfer request caused by an interrupt generated from a peripheral to which no RN (Resource Number) is assigned.

- *1: It does not support a DMA transfer by the status of the multi-function serial interface and I²C reception.
- *2: Reload timer ch.4 to ch.7 do not support a DMA transfer by the interrupt.
- *3: PPG ch.24 to ch.47 do not support a DMA transfer by the interrupt.
- *4: The clock calibration unit does not support a DMA transfer by the interrupt.
- *5: It does not support a DMA transfer by the interrupt by the RAM ECC bit error.
- *6: 32-bit Free-run timer ch.3, ch.4 and ch.5 do not support a DMA transfer by the interrupt.
- *7: There is no resource corresponding to the interrupt level.
- *8: It does not support a DMA transfer by the external low-voltage detection interrupt.

MB91520 Series

• 144pins

Interrupt factor	Interrupt number		Interrupt level	Offset	Default address for TBR	RN
	Decimal	Hexadecimal				
Reset	0	0	-	3FC _H	000FFFC _H	-
System reserved	1	1	-	3F8 _H	000FFF8 _H	-
System reserved	2	2	-	3F4 _H	000FFF4 _H	-
System reserved	3	3	-	3F0 _H	000FFF0 _H	-
System reserved	4	4	-	3EC _H	000FFFE _C	-
FPU exception	5	5	-	3E8 _H	000FFF8 _H	-
Exception of instruction access protection violation	6	6	-	3E4 _H	000FFF4 _H	-
Exception of data access protection violation	7	7	-	3E0 _H	000FFF0 _H	-
Data access error interrupt	8	8	-	3DC _H	000FFFD _C	-
INTE instruction	9	9	-	3D8 _H	000FFFD ₈	-
Instruction break	10	0A	-	3D4 _H	000FFFD ₄	-
System reserved	11	0B	-	3D0 _H	000FFFD ₀	-
System reserved	12	0C	-	3CC _H	000FFF _C	-
System reserved	13	0D	-	3C8 _H	000FFF ₈	-
Exception of invalid instruction	14	0E	-	3C4 _H	000FFF ₄	-
NMI request	15	0F	15 (F _H) Fixed	3C0 _H	000FFF ₀	-
Error generation during internal bus diagnosis						
XBS RAM double-bit error generation						
Backup RAM double-bit error generation						
TPU violation						
External interrupt 0-7	16	10	ICR00	3BC _H	000FFF _B	0
External interrupt 8-15	17	11	ICR01	3B8 _H	000FFF _B	1* ⁸
External low-voltage detection interrupt						
Reload timer 0/1/4/5	18	12	ICR02	3B4 _H	000FFF _B	2* ²
Reload timer 2/3/6/7	19	13	ICR03	3B0 _H	000FFF _B	3* ²
Multi-function serial interface ch.0 (reception completed)	20	14	ICR04	3AC _H	000FFF _A	4* ¹
Multi-function serial interface ch.0 (status)						
Multi-function serial interface ch.0 (transmission completed)	21	15	ICR05	3A8 _H	000FFF _A	5* ¹
Multi-function serial interface ch.1 (reception completed)	22	16	ICR06	3A4 _H	000FFF _A	6* ¹
Multi-function serial interface ch.1 (status)						
Multi-function serial interface ch.1 (transmission completed)	23	17	ICR07	3A0 _H	000FFF _A	7* ¹
Multi-function serial interface ch.2 (reception completed)	24	18	ICR08	39C _H	000FFF ₉	8* ¹
Multi-function serial interface ch.2 (status)						
Multi-function serial interface ch.2 (transmission completed)	25	19	ICR09	398 _H	000FFF ₉	9* ¹
Multi-function serial interface ch.3 (reception completed)	26	1A	ICR10	394 _H	000FFF ₉	10* ¹
Multi-function serial interface ch.3 (status)						
Multi-function serial interface ch.3 (transmission completed)	27	1B	ICR11	390 _H	000FFF ₉	11

MB91520 Series

Interrupt factor	Interrupt number		Interrupt level	Offset	Default address for TBR	RN
	Decimal	Hexadecimal				
Multi-function serial interface ch.4 (reception completed)	28	1C	ICR12	38C _H	000FFF8C _H	12* ¹
Multi-function serial interface ch.4 (status)						
Multi-function serial interface ch.4 (transmission completed)	29	1D	ICR13	388 _H	000FFF88 _H	13
Multi-function serial interface ch.5 (reception completed)	30	1E	ICR14	384 _H	000FFF84 _H	14* ¹
Multi-function serial interface ch.5 (status)						
Multi-function serial interface ch.5 (transmission completed)	31	1F	ICR15	380 _H	000FFF80 _H	15
Multi-function serial interface ch.6 (reception completed)	32	20	ICR16	37C _H	000FFF7C _H	16* ¹
Multi-function serial interface ch.6 (status)						
Multi-function serial interface ch.6 (transmission completed)	33	21	ICR17	378 _H	000FFF78 _H	17
CAN0	34	22	ICR18	374 _H	000FFF74 _H	-
CAN1	35	23	ICR19	370 _H	000FFF70 _H	-
RAM diagnosis end						
RAM initialization completion						
Error generation during RAM diagnosis						
Backup RAM diagnosis end						
Backup RAM initialization completion						
Error generation during Backup RAM diagnosis						
CAN2	36	24	ICR20	36C _H	000FFF6C _H	-
Up/down counter 0						
Up/down counter 1						
Real time clock	37	25	ICR21	368 _H	000FFF68 _H	-
Multi-function serial interface ch.7 (reception completed)	38	26	ICR22	364 _H	000FFF64 _H	22* ¹
Multi-function serial interface ch.7 (status)						
16-bit Free-run timer 0 (0 detection) / (compare clear)	39	27	ICR23	360 _H	000FFF60 _H	23
Multi-function serial interface ch.7 (transmission completed)						
PPG 0/1/10/11/20/21/30/31/40/41	40	28	ICR24	35C _H	000FFF5C _H	24* ³
16-bit Free-run timer 1 (0 detection) / (compare clear)						
PPG 2/3/12/13/22/23/32/33/42/43	41	29	ICR25	358 _H	000FFF58 _H	25* ³
16-bit Free-run timer 2 (0 detection) / (compare clear)						
PPG 4/5/14/15/24/25/34/35/44	42	2A	ICR26	354 _H	000FFF54 _H	26* ³
PPG 6/7/16/17/26/27/36/37	43	2B	ICR27	350 _H	000FFF50 _H	27* ³
PPG 8/9/18/19/28/29/38/39	44	2C	ICR28	34C _H	000FFF4C _H	28* ³

MB91520 Series

Interrupt factor	Interrupt number		Interrupt level	Offset	Default address for TBR	RN
	Decimal	Hexadecimal				
Multi-function serial interface ch.8 (reception completed)	45	2D	ICR29	348 _H	000FFF48 _H	29* ¹
Multi-function serial interface ch.8 (status)						
16-bit ICU 0 (fetching) / 16-bit ICU 1 (fetching)						
Main timer	46	2E	ICR30	344 _H	000FFF44 _H	30
Sub timer						
PLL timer						
Multi-function serial interface ch.8 (transmission completed)						
16-bit ICU 2 (fetching) / 16-bit ICU 3 (fetching)	47	2F	ICR31	340 _H	000FFF40 _H	31* ¹ , * ⁴
Clock calibration unit (sub oscillation)						
Multi-function serial interface ch.9 (reception completed)						
Multi-function serial interface ch.9 (status)	48	30	ICR32	33C _H	000FFF3C _H	32
A/D converter 0/1/2/3/4/5/6/7/8/9/10/11/12/13/14/15/16						
17/18/19/20/21/22/23/24/25/26/27/28/29/30/31						
Clock calibration unit (CR oscillation)	49	31	ICR33	338 _H	000FFF38 _H	33
Multi-function serial interface ch.9 (transmission completed)						
16-bit OCU 0 (match) / 16-bit OCU 1 (match)						
32-bit Free-run timer 4	50	32	ICR34	334 _H	000FFF34 _H	34* ⁶
16-bit OCU 2 (match) / 16-bit OCU 3 (match)						
32-bit Free-run timer 3/5	51	33	ICR35	330 _H	000FFF30 _H	35* ⁶
16-bit OCU 4 (match) / 16-bit OCU 5 (match)						
32-bit ICU 6 (fetching/measurement)	52	34	ICR36	32C _H	000FFF2C _H	36* ¹
Multi-function serial interface ch.10 (reception completed)						
Multi-function serial interface ch.10 (status)						
32-bit ICU7 (fetching/measurement)	53	35	ICR37	328 _H	000FFF28 _H	37
Multi-function serial interface ch.10 (transmission completed)						
32-bit ICU8 (fetching/measurement)						
Multi-function serial interface ch.11 (reception completed)	54	36	ICR38	324 _H	000FFF24 _H	38* ¹
Multi-function serial interface ch.11 (status)						
32-bit ICU9 (fetching/measurement)						
WG dead timer underflow 0 / 1/ 2	55	37	ICR39	320 _H	000FFF20 _H	39
WG dead timer reload 0 / 1/ 2						
WG DTI 0						
32-bit ICU4 (fetching/measurement)	56	38	ICR40	31C _H	000FFF1C _H	40
Multi-function serial interface ch.11 (transmission completed)						
32-bit ICU5 (fetching/measurement)						
A/D converter 32/33/34/35/36/37/38/39/40/41/42/43/44/45/46/47	57	39	ICR41	318 _H	000FFF18 _H	41
32-bit OCU 6/7/10/11 (match)						
32-bit OCU 6/7/10/11 (match)	58	3A	ICR42	314 _H	000FFF14 _H	42

Interrupt factor	Interrupt number		Interrupt level	Offset	Default address for TBR	RN
	Decimal	Hexadecimal				
32-bit OCU8/9 (match)	59	3B	ICR43	310 _H	000FFF10 _H	43
Base timer 0 IRQ0	60	3C	ICR44	30C _H	000FFF0C _H	44
Base timer 0 IRQ1						
Base timer 1 IRQ0	61	3D	ICR45	308 _H	000FFF08 _H	45* ⁵
Base timer 1 IRQ1						
-						
-						
DMAC 0/1/2/3/4/5/6/7/8/9/10/11/12/13/14/15	62	3E	ICR46	304 _H	000FFF04 _H	-
Delay interrupt	63	3F	ICR47	300 _H	000FFF00 _H	-
System reserved (Used for REALOS)	64	40	-	2FC _H	000FFEFC _H	-
System reserved (Used for REALOS)	65	41	-	2F8 _H	000FFE8 _H	-
Used with the INT instruction	66	42	-	2F4 _H	000FFE4 _H	-
	 255	 FF		 000 _H	 000FFC00 _H	

Note: It does not support a DMA transfer request caused by an interrupt generated from a peripheral to which no RN (Resource Number) is assigned.

*1: It does not support a DMA transfer by the status of the multi-function serial interface and I²C reception.

*2: Reload timer ch.4 to ch.7 do not support a DMA transfer by the interrupt.

*3: PPG ch.24 to ch.47 do not support a DMA transfer by the interrupt.

*4: The clock calibration unit does not support a DMA transfer by the interrupt.

*5: It does not support a DMA transfer by the interrupt by the RAM ECC bit error.

*6: 32-bit Free-run timer ch.3, ch.4 and ch.5 do not support a DMA transfer by the interrupt.

*7: There is no resource corresponding to the interrupt level.

*8: It does not support a DMA transfer by the external low-voltage detection interrupt.

MB91520 Series

• 176pins

Interrupt factor	Interrupt number		Interrupt level	Offset	Default address for TBR	RN
	Decimal	Hexadecimal				
Reset	0	0	-	3FC _H	000FFFFC _H	-
System reserved	1	1	-	3F8 _H	000FFFF8 _H	-
System reserved	2	2	-	3F4 _H	000FFFF4 _H	-
System reserved	3	3	-	3F0 _H	000FFFF0 _H	-
System reserved	4	4	-	3EC _H	000FFFE _C	-
FPU exception	5	5	-	3E8 _H	000FFFE8 _H	-
Exception of instruction access protection violation	6	6	-	3E4 _H	000FFFE4 _H	-
Exception of data access protection violation	7	7	-	3E0 _H	000FFFE0 _H	-
Data access error interrupt	8	8	-	3DC _H	000FFFD _C	-
INTE instruction	9	9	-	3D8 _H	000FFFD8 _H	-
Instruction break	10	0A	-	3D4 _H	000FFFD4 _H	-
System reserved	11	0B	-	3D0 _H	000FFFD0 _H	-
System reserved	12	0C	-	3CC _H	000FFFC _C	-
System reserved	13	0D	-	3C8 _H	000FFFC8 _H	-
Exception of invalid instruction	14	0E	-	3C4 _H	000FFFC4 _H	-
NMI request	15	0F	15 (F _H) Fixed	3C0 _H	000FFFC0 _H	-
Error generation during internal bus diagnosis						
XBS RAM double-bit error generation						
Backup RAM double-bit error generation						
TPU violation						
External interrupt 0-7	16	10	ICR00	3BC _H	000FFFBC _H	0
External interrupt 8-15	17	11	ICR01	3B8 _H	000FFFB8 _H	1* ⁸
External low-voltage detection interrupt						
Reload timer 0/1/4/5	18	12	ICR02	3B4 _H	000FFFB4 _H	2* ²
Reload timer 2/3/6/7	19	13	ICR03	3B0 _H	000FFFB0 _H	3* ²
Multi-function serial interface ch.0 (reception completed)	20	14	ICR04	3AC _H	000FFFAC _H	4* ¹
Multi-function serial interface ch.0 (status)						
Multi-function serial interface ch.0 (transmission completed)	21	15	ICR05	3A8 _H	000FFFA8 _H	5* ¹
Multi-function serial interface ch.1 (reception completed)	22	16	ICR06	3A4 _H	000FFFA4 _H	6* ¹
Multi-function serial interface ch.1 (status)						
Multi-function serial interface ch.1 (transmission completed)	23	17	ICR07	3A0 _H	000FFFA0 _H	7* ¹
Multi-function serial interface ch.2 (reception completed)	24	18	ICR08	39C _H	000FFF9C _H	8* ¹
Multi-function serial interface ch.2 (status)						
Multi-function serial interface ch.2 (transmission completed)	25	19	ICR09	398 _H	000FFF98 _H	9* ¹
Multi-function serial interface ch.3 (reception completed)	26	1A	ICR10	394 _H	000FFF94 _H	10* ¹
Multi-function serial interface ch.3 (status)						
Multi-function serial interface ch.3 (transmission completed)	27	1B	ICR11	390 _H	000FFF90 _H	11

MB91520 Series

Interrupt factor	Interrupt number		Interrupt level	Offset	Default address for TBR	RN
	Decimal	Hexadecimal				
Multi-function serial interface ch.4 (reception completed)	28	1C	ICR12	38C _H	000FFF8C _H	12* ¹
Multi-function serial interface ch.4 (status)						
Multi-function serial interface ch.4 (transmission completed)	29	1D	ICR13	388 _H	000FFF88 _H	13
Multi-function serial interface ch.5 (reception completed)	30	1E	ICR14	384 _H	000FFF84 _H	14* ¹
Multi-function serial interface ch.5 (status)						
Multi-function serial interface ch.5 (transmission completed)	31	1F	ICR15	380 _H	000FFF80 _H	15
Multi-function serial interface ch.6 (reception completed)	32	20	ICR16	37C _H	000FFF7C _H	16* ¹
Multi-function serial interface ch.6 (status)						
Multi-function serial interface ch.6 (transmission completed)	33	21	ICR17	378 _H	000FFF78 _H	17
CAN0	34	22	ICR18	374 _H	000FFF74 _H	-
CAN1	35	23	ICR19	370 _H	000FFF70 _H	-
RAM diagnosis end						
RAM initialization completion						
Error generation during RAM diagnosis						
Backup RAM diagnosis end						
Backup RAM initialization completion						
Error generation during Backup RAM diagnosis						
CAN2	36	24	ICR20	36C _H	000FFF6C _H	-
Up/down counter 0						
Up/down counter 1						
Real time clock	37	25	ICR21	368 _H	000FFF68 _H	-
Multi-function serial interface ch.7 (reception completed)	38	26	ICR22	364 _H	000FFF64 _H	22* ¹
Multi-function serial interface ch.7 (status)						
16-bit Free-run timer 0 (0 detection) / (compare clear)	39	27	ICR23	360 _H	000FFF60 _H	23
Multi-function serial interface ch.7 (transmission completed)						
PPG 0/1/10/11/20/21/30/31/40/41	40	28	ICR24	35C _H	000FFF5C _H	24* ³
16-bit Free-run timer 1 (0 detection) / (compare clear)						
PPG 2/3/12/13/22/23/32/33/42/43	41	29	ICR25	358 _H	000FFF58 _H	25* ³
16-bit Free-run timer 2 (0 detection) / (compare clear)						
PPG 4/5/14/15/24/25/34/35/44/45	42	2A	ICR26	354 _H	000FFF54 _H	26* ³
PPG 6/7/16/17/26/27/36/37/46/47	43	2B	ICR27	350 _H	000FFF50 _H	27* ³
PPG 8/9/18/19/28/29/38/39	44	2C	ICR28	34C _H	000FFF4C _H	28* ³
Multi-function serial interface ch.8 (reception completed)	45	2D	ICR29	348 _H	000FFF48 _H	29* ¹
Multi-function serial interface ch.8 (status)						
16-bit ICU 0 (fetching) / 16-bit ICU 1 (fetching)						

MB91520 Series

Interrupt factor	Interrupt number		Interrupt level	Offset	Default address for TBR	RN
	Decimal	Hexadecimal				
Main timer	46	2E	ICR30	344 _H	000FFF44 _H	30
Sub timer						
PLL timer						
Multi-function serial interface ch.8 (transmission completed)						
16-bit ICU 2 (fetching) / 16-bit ICU 3 (fetching)						
Clock calibration unit (sub oscillation)	47	2F	ICR31	340 _H	000FFF40 _H	31* ¹ , * ⁴
Multi-function serial interface ch.9 (reception completed)						
Multi-function serial interface ch.9 (status)						
A/D converter 0/1/2/3/4/5/6/7/8/9/10/11/12/13/14/15/16 17/18/19/20/21/22/23/24/25/26/27/28/29/30/31	48	30	ICR32	33C _H	000FFF3C _H	32
Clock calibration unit (CR oscillation)	49	31	ICR33	338 _H	000FFF38 _H	33
Multi-function serial interface ch.9 (transmission completed)						
16-bit OCU 0 (match) / 16-bit OCU 1 (match)						
32-bit Free-run timer 4						
16-bit OCU 2 (match) / 16-bit OCU 3 (match)	50	32	ICR34	334 _H	000FFF34 _H	34* ⁶
32-bit Free-run timer 3/5	51	33	ICR35	330 _H	000FFF30 _H	35* ⁶
16-bit OCU 4 (match) / 16-bit OCU 5 (match)						
32-bit ICU6 (fetching/measurement)	52	34	ICR36	32C _H	000FFF2C _H	36* ¹
Multi-function serial interface ch.10 (reception completed)						
Multi-function serial interface ch.10 (status)						
32-bit ICU7 (fetching/measurement)	53	35	ICR37	328 _H	000FFF28 _H	37
Multi-function serial interface ch.10 (transmission completed)						
32-bit ICU8 (fetching/measurement)	54	36	ICR38	324 _H	000FFF24 _H	38* ¹
Multi-function serial interface ch.11 (reception completed)						
Multi-function serial interface ch.11 (status)						
32-bit ICU9 (fetching/measurement)	55	37	ICR39	320 _H	000FFF20 _H	39
WG dead timer underflow 0/1/2						
WG dead timer reload 0/1/2						
WG DTTI 0						
32-bit ICU4 (fetching/measurement)	56	38	ICR40	31C _H	000FFF1C _H	40
Multi-function serial interface ch.11 (transmission completed)						
32-bit ICU5 (fetching/measurement)	57	39	ICR41	318 _H	000FFF18 _H	41
A/D converter 32/33/34/35/36/37/38/39/40/41/42/43/44/45/46/ 47						
32-bit OCU 6/7/10/11 (match)	58	3A	ICR42	314 _H	000FFF14 _H	42
32-bit OCU 8/9 (match)	59	3B	ICR43	310 _H	000FFF10 _H	43
Base timer 0 IRQ0	60	3C	ICR44	30C _H	000FFF0C _H	44
Base timer 0 IRQ1						

Interrupt factor	Interrupt number		Interrupt level	Offset	Default address for TBR	RN
	Decimal	Hexadecimal				
Base timer 1 IRQ0	61	3D	ICR45	308 _H	000FFF08 _H	45* ⁵
Base timer 1 IRQ1						
-						
-						
DMAC 0/1/2/3/4/5/6/7/8/9/10/11/12/13/14/15	62	3E	ICR46	304 _H	000FFF04 _H	-
Delay interrupt	63	3F	ICR47	300 _H	000FFF00 _H	-
System reserved (Used for REALOS)	64	40	-	2FC _H	000FFEFC _H	-
System reserved (Used for REALOS)	65	41	-	2F8 _H	000FFE8 _H	-
Used with the INT instruction	66	42	-	2F4 _H	000FFE4 _H	-
	 255	 FF		 000 _H	 000FFC00 _H	

Note: It does not support a DMA transfer request caused by an interrupt generated from a peripheral to which no RN (Resource Number) is assigned.

- *1: It does not support a DMA transfer by the status of the multi-function serial interface and I²C reception.
- *2: Reload timer ch.4 to ch.7 do not support a DMA transfer by the interrupt.
- *3: PPG ch.24 to ch.47 do not support a DMA transfer by the interrupt.
- *4: The clock calibration unit does not support a DMA transfer by the interrupt.
- *5: It does not support a DMA transfer by the interrupt by the RAM ECC bit error.
- *6: 32-bit Free-run timer ch.3, ch.4 and ch.5 do not support a DMA transfer by the interrupt.
- *7: There is no resource corresponding to the interrupt level.
- *8: It does not support a DMA transfer by the external low-voltage detection interrupt.

MB91520 Series

■ ELECTRICAL CHARACTERISTICS

1. Absolute Maximum Ratings

Parameter	Symbol	Rating		Unit	Remarks	
		Min	Max			
Power supply voltage *1,*2	V_{CC}	$V_{SS}-0.3$	$V_{SS}+6.0$	V		
Analog power supply voltage *1,*2	AV_{CC}	$V_{SS}-0.3$	$V_{SS}+6.0$	V	$AVRH \leq AV_{CC} \leq V_{CC}$	
Analog reference voltage *1	$AVRH$	$V_{SS}-0.3$	$V_{SS}+6.0$	V	$AVRH \leq AV_{CC}$	
Input voltage *1	V_I	$V_{SS}-0.3$	$V_{CC}+0.3$	V		
Analog pin input voltage *1	V_{IA5}	$V_{SS}-0.3$	$V_{CC}+0.3$	V		
Output voltage *1	V_o	$V_{SS}-0.3$	$V_{CC}+0.3$	V		
Maximum clamp current	I_{CLAMP}	-	4.0	mA	*6	
Total maximum clamp current	$\Sigma I_{CLAMP} $	-	20	mA	*6	
"L" level maximum output current *3	I_{OL1}	-	15	mA		
	I_{OL2}	-	30	mA		
"L" level average output current *4	I_{OLAV1}	-	4	mA		
	I_{OLAV2}	-	12	mA		
"L" level total output current *5	ΣI_{OL1}	-	100	mA		
	ΣI_{OL2}	-	120	mA		
"H" level maximum output current*3	I_{OH1}	-	-15	mA		
	I_{OH2}	-	-30	mA		
"H" level average output current*4	I_{OHAV1}	-	-4	mA		
	I_{OHAV2}	-	-12	mA		
"H" level total output current *5	ΣI_{OH1}	-	-100	mA		
	ΣI_{OH2}	-	-120	mA		
Power consumption	$T_A: -40^\circ\text{C}$ to $+105^\circ\text{C}$	P_D	-	882	mW	*8
	$T_A: -40^\circ\text{C}$ to $+125^\circ\text{C}$		-	675	mW	*8
Operating temperature	T_A	-40	+105	$^\circ\text{C}$		
		-40	+125	$^\circ\text{C}$		*7
Storage temperature	T_{stg}	-55	+150	$^\circ\text{C}$		

*1: These parameters are based on the condition that $V_{SS}=AV_{SS}=0.0\text{V}$

*2: Caution must be taken that AV_{CC} , $AVRH$ do not exceed V_{CC} upon power-on and under other circumstances.

*3: The maximum output current is defined as the value of the peak current flowing through any one of the corresponding pins.

*4: The average output current is defined as the value of the average current flowing through any one of the corresponding pins for a 10 ms period. The average value is the operation current \times the operation ratio.

*5: The total output current is defined as the maximum current value flowing through all of corresponding pins.

- *6:
- Corresponding pins: all general-purpose ports except P035, 041, 093, 122.
 - Use within recommended operating conditions.
 - Use at DC voltage (current).
 - The + B signal should always be applied by connecting a limiting resistor between the + B signal and the microcontroller.
 - The value of the limiting resistor should be set so that the current input to the microcontroller pin does not exceed rated values at any time regardless of instantaneously or constantly when the + B signal is input.
 - Note that when the microcontroller drive current is low, such as in the low power consumption modes, the + B input potential can increase the potential at the V_{CC} pin via a protective diode, possibly affecting other devices.
 - Note that if the + B signal is input when the microcontroller is off (not fixed at 0 V), since the power is supplied through the pin, the microcontroller may operate incompletely.
 - Note that if the +B signal is input at power-on, since the power is supplied through the pin, the power-on reset may not function in the power supply voltage.
 - Do not leave + B input pins open.
- *7: When it is used under this condition, contact your sales representative.
- *8: It is a standard when four-layer substrate is used.

Sample recommended circuit

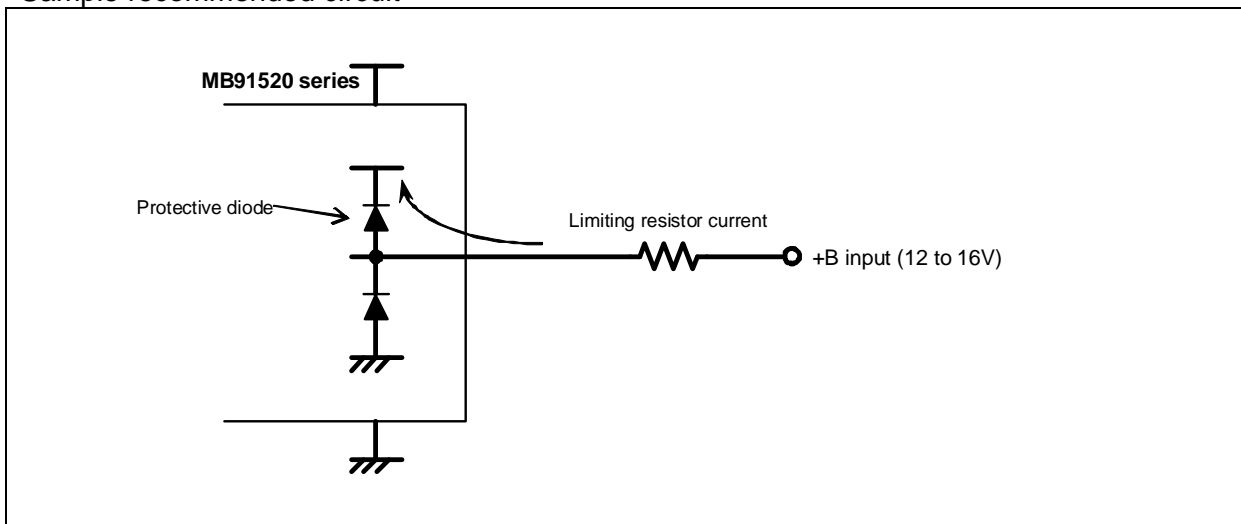

<WARNING>

Semiconductor devices may be permanently damaged by application of stress (including, without limitation, voltage, current or temperature) in excess of absolute maximum ratings. Do not exceed any of these ratings.

MB91520 Series

2. Recommended operating conditions

($V_{SS}=AV_{SS}=0.0V$)

Parameter	Symbol	Value		Unit	Remarks
		Min	Max		
Power supply voltage	V_{CC} , AV_{CC}	4.5	5.5	V	Recommended operation guarantee range (When 5.0V is used)
		3.0	3.6	V	Recommended operation guarantee range (When 3.3V is used)
		2.7	5.5	V	Operation guarantee range ^{*1}
Smoothing capacitor ^{*2}	C_S	4.7 (tolerance within $\pm 50\%$)		μF	Use a ceramic capacitor or a capacitor that has the similar frequency characteristics. Use a capacitor with a capacitance greater than C_S as the smoothing capacitor on the VCC pin.
Operating temperature	T_A	-40	+105	$^{\circ}C$	
		-40	+125	$^{\circ}C$	*3

*1: When it is used outside recommended operation guarantee range (range of the operation guarantee), contact your sales representative.

*2: See the following diagram for details on the connection of smoothing capacitor C_S .

*3: When it is used under this condition, contact your sales representative.

• C Pin Connection Diagram

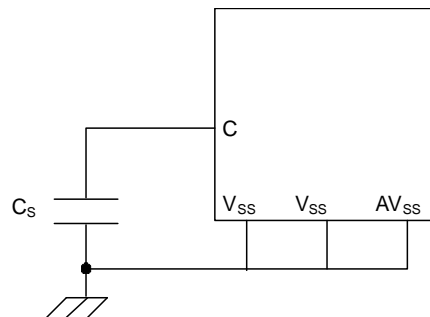

<WARNING>

The recommended operating conditions are required in order to ensure the normal operation of the semiconductor device. All of the device's electrical characteristics are warranted when the device is operated under these conditions.

Any use of semiconductor devices will be under their recommended operating condition. Operation under any conditions other than these conditions may adversely affect reliability of device and could result in device failure. No warranty is made with respect to any use, operating conditions or combinations not represented on this data sheet. If you are considering application under any conditions other than listed herein, please contact sales representatives beforehand.

3. DC characteristics

(T_A: -40°C to +105°C, V_{CC}=AV_{CC}=2.7V to 5.5V, V_{SS}=AV_{SS}=0.0V)

Parameter	Symbol	Pin name	Conditions	Value			Unit	Remarks
				Min	Typ	Max		
Power supply current	I _{CC5}	VCC	Operating frequency F _{CP} =80MHz, F _{cpp} =40MHz, at normal operation	-	60	80	mA	
			Operating frequency F _{CP} =80MHz, F _{cpp} =40MHz, at Flash write	-	70	90	mA	
			Operating frequency F _{CP} =80MHz, F _{cpp} =40MHz, at Flash erase	-	70	90	mA	
			Operating frequency F _{CP} =64MHz, F _{cpp} =32MHz, at normal operation	-	54	71	mA	
			Operating frequency F _{CP} =64MHz, F _{cpp} =32MHz, at Flash write	-	64	81	mA	
			Operating frequency F _{CP} =64MHz, F _{cpp} =32MHz, at Flash erase	-	64	81	mA	
			Operating frequency F _{CP} =48MHz, F _{cpp} =24MHz, at normal operation	-	46	62	mA	
			Operating frequency F _{CP} =48MHz, F _{cpp} =24MHz, at Flash write	-	56	72	mA	
			Operating frequency F _{CP} =48MHz, F _{cpp} =24MHz, at Flash erase	-	56	72	mA	
	I _{CCS5}		Operating frequency F _{CP} =80MHz, F _{cpp} =40MHz, at CPU sleep mode	-	45	61	mA	
	I _{CCBS5}		Operating frequency F _{CP} =80MHz, F _{cpp} =40MHz, at bus sleep mode	-	23	51	mA	
	I _{CCT5}	Watch mode	When using crystal 4MHz T _A =+25°C*	-	1500	2610	μA	
			When using built-in CR clock 50kHz T _A =+25°C*	-	450	2000		
			When using sub clock 32kHz T _A =+25°C*	-	460	1420		
I _{CCH5}	Stop mode	T _A =+25°C*	-	450	2000	μA		
I _{CCT52}	Watch mode (power off)	When using crystal 4MHz T _A =+25°C*	-	1100	1300	μA	LVD/ RTC operation, Backup RAM 8KB retention	
		When using built-in CR clock 50kHz, T _A =+25°C*	-	77	267			
		When using sub clock 32kHz T _A =+25°C*	-	100	285			
I _{CCH52}	Stop mode (power off)	T _A =+25°C*	-	74	265	μA	Backup RAM 8KB retention	

MB91520 Series

(T_A: -40°C to +125°C, V_{CC}=AV_{CC}=2.7V to 5.5V, V_{SS}=AV_{SS}=0.0V)

Parameter	Symbol	Pin name	Conditions	Value			Unit	Remarks
				Min	Typ	Max		
Power supply current	I _{CC5}	VCC	Operating frequency F _{CP} =80MHz, F _{cpp} =40MHz, at normal operation	-	60	102	mA	
			Operating frequency F _{CP} =80MHz, F _{cpp} =40MHz, at Flash write	-	70	115	mA	
			Operating frequency F _{CP} =80MHz, F _{cpp} =40MHz, at Flash erase	-	70	115	mA	
			Operating frequency F _{CP} =64MHz, F _{cpp} =32MHz, at normal operation	-	54	92	mA	
			Operating frequency F _{CP} =64MHz, F _{cpp} =32MHz, at Flash write	-	64	105	mA	
			Operating frequency F _{CP} =64MHz, F _{cpp} =32MHz, at Flash erase	-	64	105	mA	
			Operating frequency F _{CP} =48MHz, F _{cpp} =24MHz, at normal operation	-	46	82	mA	
			Operating frequency F _{CP} =48MHz, F _{cpp} =24MHz, at Flash write	-	56	95	mA	
			Operating frequency F _{CP} =48MHz, F _{cpp} =24MHz, at Flash erase	-	56	95	mA	
			Operating frequency F _{CP} =80MHz, F _{cpp} =40MHz, at CPU sleep mode	-	45	82	mA	
	I _{CCS5}		Operating frequency F _{CP} =80MHz, F _{cpp} =40MHz, at bus sleep mode	-	23	72	mA	
	I _{CCR5}	Watch mode	When using crystal 4MHz T _A =+25°C*	-	1500	2610	μA	
			When using built-in CR clock 50kHz T _A =+25°C*	-	450	2000		
			When using sub clock 32kHz T _A =+25°C*	-	460	1420		
I _{CCH5}	Stop mode	T _A =+25°C*	-	450	2000	μA		
I _{CCR52}	Watch mode (power off)	When using crystal 4MHz T _A =+25°C*	-	1100	1300	μA	LVD/ RTC operation, Backup RAM 8KB retention	
		When using built-in CR clock 50kHz, T _A =+25°C*	-	77	267			
		When using sub clock 32kHz T _A =+25°C*	-	100	285			
I _{CCH52}	Stop mode (power off)	T _A =+25°C*	-	74	265	μA	Backup RAM 8KB retention	

MB91520 Series

(T_A: -40°C to +125°C, V_{CC}=AV_{CC}=5.0V ± 10%/V_{CC}=AV_{CC}=3.3V±0.3V, V_{SS}=AV_{SS}=0.0V)

Parameter	Symbol	Pin name	Conditions	Value			Unit	Remarks		
				Min	Typ	Max				
Input leak current	I _{IL}	All input pins	V _{CC} =AV _{CC} =5.5V V _{SS} <V _I <V _{CC}	-5	-	5	μA			
Input capacitance 1	C _{IN1}	Other than VCC,VSS, AVCC, AVSS, C	-	-	5	15	pF			
Pull-up resistance	R _{UP1}	RSTX, NMIX	V _{CC} =5.0V±10%	25	-	100	kΩ			
			V _{CC} =3.3V±0.3V	49	-	140				
	R _{UP2}	Port pin other than P035,041,093, 122	V _{CC} =5.0V±10%	25	-	100	kΩ			
			V _{CC} =3.3V±0.3V	49	-	140				
“H” level output voltage	V _{OH1}	Normal output pin	V _{CC} =4.5V I _{OH} =-4.0mA	V _{CC} -0.5	-	V _{CC}	V			
			V _{CC} =3.0V I _{OH} =-2.0mA							
	V _{OH2}	P073,074,076, 077	V _{CC} =4.5V I _{OH} =-3.0mA	V _{CC} -0.5	-	V _{CC}	V	I ² C pin output		
V _{OH3}	P103 to 106	V _{CC} =4.5V I _{OH} =-12.0mA	V _{CC} -0.5	-	V _{CC}	V				
		V _{CC} =3.0V I _{OH} =-8.0mA								
“L” level output voltage	V _{OL1}	Normal output pin	V _{CC} =4.5V I _{OL} =4.0mA	0	-	0.4	V			
			V _{CC} =3.0V I _{OL} =2.0mA							
	V _{OL2}	P073,074,076, 077	V _{CC} =4.5V I _{OL} =3.0mA	0	-	0.4	V	I ² C pin output		
V _{OL3}	P103 to 106	V _{CC} =4.5V I _{OL} =12.0mA	0	-	0.4	V				
		V _{CC} =3.0V I _{OL} =8.0mA								
“H” level input voltage	V _{IH1}	P000,002,003, 005,020,022, 024,026,150, 151,035,041, 045,055,057, 071-077,081, 082,093,096, 097,100-102, 111,115,116, 122,126,130, 134,142,143, 144,153	CMOS hysteresis input level	0.7× V _{CC}	-	V _{CC}	V			
			V _{IH3}	Port other than V _{IH1}	Automotive input level	0.8× V _{CC}	-	V _{CC}	V	
			V _{IH5}	RSTX,NMIX, MD0,MD1	CMOS hysteresis input level	0.8× V _{CC}	-	V _{CC}	V	
			V _{IHT}	DEBUGIF	TTL input level	2	-	V _{CC}	V	

MB91520 Series

Parameter	Symbol	Pin name	Conditions	Value			Unit	Remarks
				Min	Typ	Max		
“L” level input voltage	V_{IL1}	P000,002,003, 005,020,022, 024,026,150, 151,035,041, 045,055,057, 071-077,081, 082,093,096, 097,100-102, 111,115,116, 122,126,130, 134,142,143, 144,153	CMOS hysteresis input level	V_{SS}	-	$0.3 \times V_{CC}$	V	
	V_{IL3}	Port other than V_{IH1}	Automotive input level	V_{SS}	-	$0.5 \times V_{CC}$	V	
	V_{IL5}	RSTX,NMIX, MD0,MD1	CMOS hysteresis input level	V_{SS}	-	$0.2 \times V_{CC}$	V	
	V_{ILT}	DEBUGIF	TTL input level	V_{SS}	-	0.8	V	

*: It is a standard in BRAMSC (Backup RAM sleep control bit)=1(Enter the state of the sleep at the standby mode) condition.

4. AC Characteristics

(1) Main Clock Timing

(T_A: -40°C to +125°C, V_{CC}=AV_{CC}=5.0V ± 10%/V_{CC}=AV_{CC}=3.3V ± 0.3V, V_{SS}=AV_{SS}=0.0V)

Parameter	Symbol	Pin name	Conditions	Value			Unit	Remarks
				Min	Typ	Max		
Source oscillation clock frequency	F _C	X0, X1		-	4	16	MHz	
Source oscillation clock cycle time	t _{CYL}	X0, X1		62.5	250	-	ns	
Internal operating clock frequency ^{*1}	F _{CP}	-	-	2	-	80	MHz	CPU clock
	F _{CPP}			1		40		Peripheral bus clock
	F _{CPT}			1		40		External bus clock (When V _{CC} =5.0V is used) ^{*2}
				1		32		External bus clock (When V _{CC} =3.3V is used)
Internal operating clock cycle time ^{*1}	t _{CP}	-	-	12.5	-	500	ns	CPU clock
	t _{CPP}			25		1000		Peripheral bus clock
	t _{CPT}			25		1000		External bus clock (When V _{CC} =5.0V is used)
				31.25		1000		External bus clock (When V _{CC} =3.3V is used)
CAN PLL jitter (during lock)	t _{PJ}	-		-10	-	10	ns	F _{CP} =80MHz (4MHz × Multiplied by 20)
Built-in CR oscillation frequency	F _{CCR}	-		50	100	150	kHz	

*1: The maximum / minimum value is defined when using the main clock and PLL clock.

*2: Please use it with external load capacity 12pF or less for V_{CC}=3.3V±0.3V (40MHz operation).

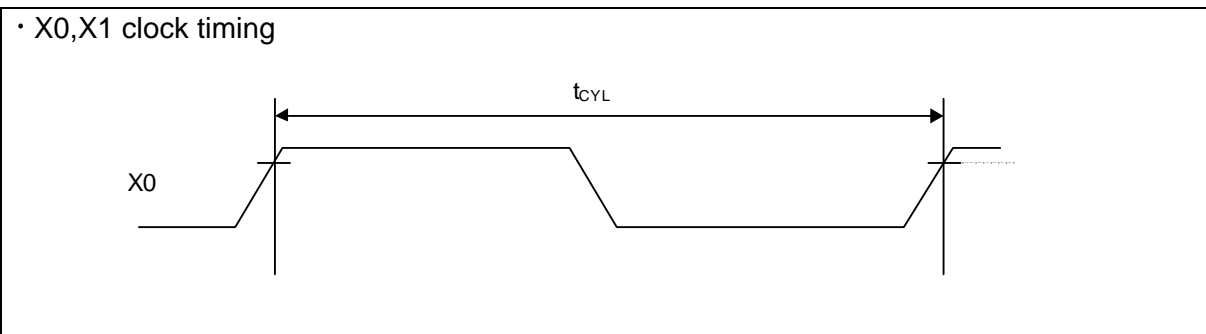

• CAN PLL jitter

Deviation time from the ideal clock is assured per cycle out of 20,000 cycles.

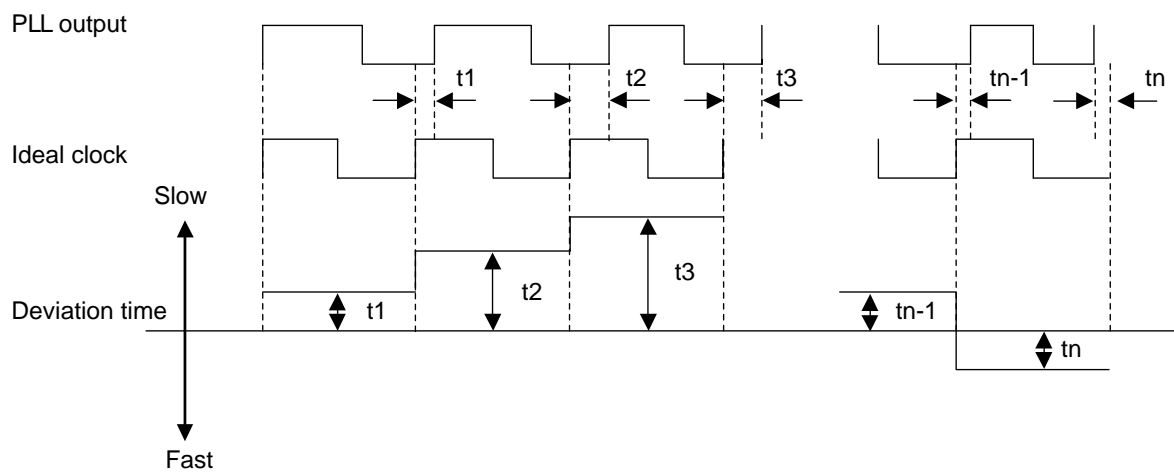

(1-2) Sub clock timing

(T_A : -40°C to $+125^{\circ}\text{C}$, $V_{CC}=AV_{CC}=5.0\text{V} \pm 10\%$ / $V_{CC}=AV_{CC}=3.3\text{V} \pm 0.3\text{V}$, $V_{SS}=AV_{SS}=0.0\text{V}$)

Parameter	Symbol	Pin name	Conditions	Value			Unit	Remarks
				Min	Typ	Max		
Source oscillation clock frequency	F_{CL}	X0A, X1A	-	-	32.768	-	kHz	
Source oscillation clock cycle time	t_{LCYL}	X0A, X1A		-	30.52	-		

• X0A,X1A clock timing

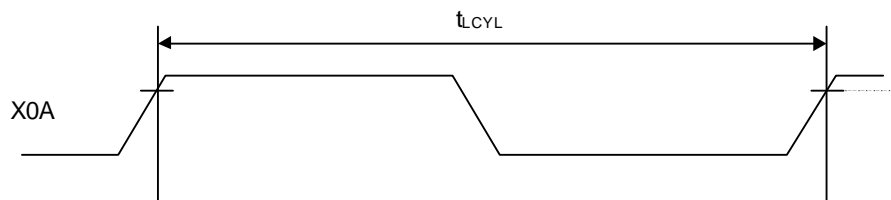

MB91520 Series

• Guaranteed operation range

Internal operation clock frequency vs. Power supply voltage

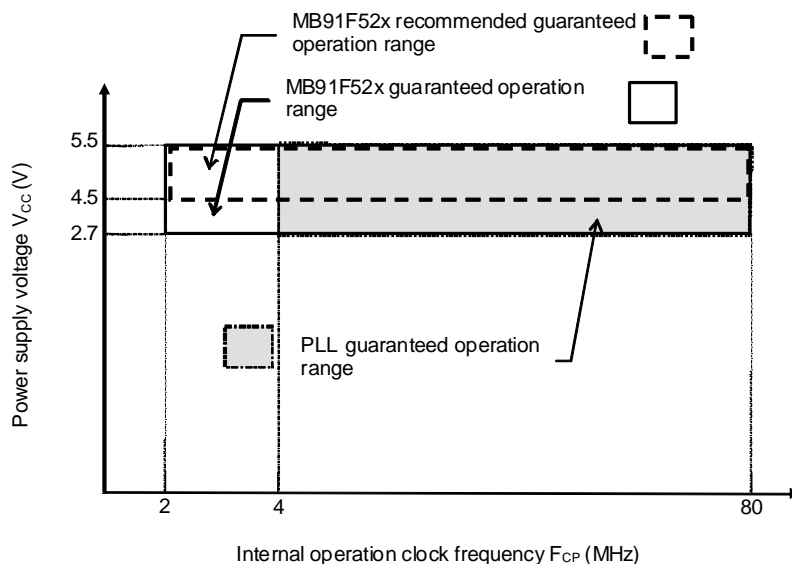

Note: The power supply voltage, which is the low-voltage detection setting voltage or lower, is in the reset state.

Oscillation clock frequency vs. Internal operation clock frequency

		Internal operation clock frequency							
		Main Clock	PLL clock						
			Multiplied by 1	Multiplied by 2	Multiplied by 3	Multiplied by 4	...	Multiplied by 19	Multiplied by 20
Oscillation clock frequency	4MHz	2MHz	4MHz	8MHz	12MHz	16MHz	...	76MHz	80MHz

• Example of oscillation circuit

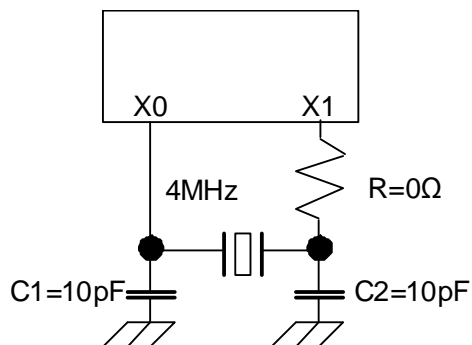

Note: As to the product with its clock supervisor's initial value is "ON", when the oscillator is unable to start within 20ms from the stop state the clock supervisor will detect the oscillation stop. As a result, the CPU moves to the fail safe operation.

Design your print circuit board so that the oscillator can start oscillation within 20ms. Moreover, it is recommended to be designed after the match evaluation of the circuit is requested to the departure pendulum maker when the oscillation circuit is composed.

AC characteristics are specified by the following measurement reference voltage values.

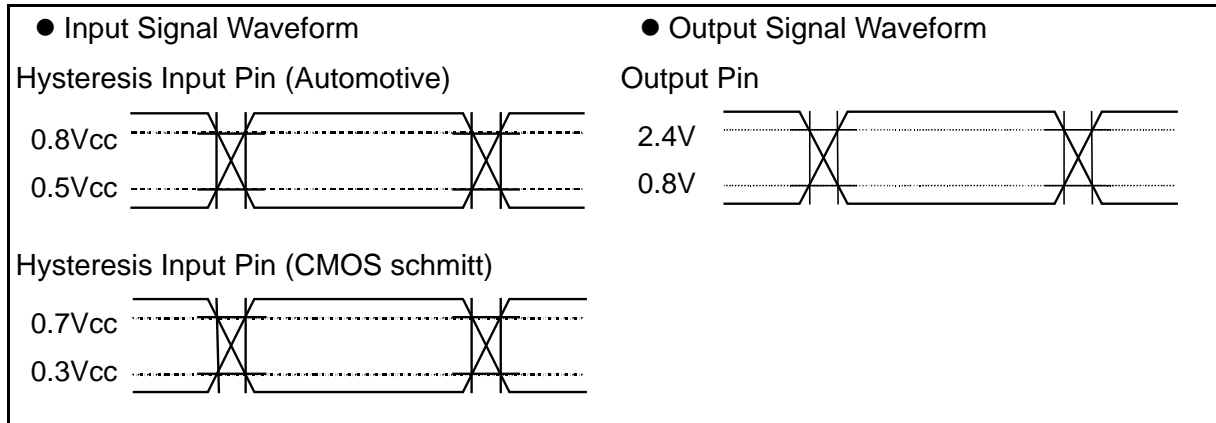

MB91520 Series

(2) Reset Input

(T_A : -40°C to +125°C, $V_{CC}=AV_{CC}=5.0V \pm 10\%/V_{CC}=AV_{CC}=3.3V \pm 0.3V$, $V_{SS}=AV_{SS}=0.0V$)

Parameter	Symbol	Pin name	Conditions	Value		Unit	Remarks	
				Min	Max			
Reset input time	t_{RSTL}	RSTX	-	10	-	μs	When normal operation	
				Oscillation time of oscillator*		-	μs	At Stop mode
				100	-	μs	At Watch mode	
Width for reset input removal				1	-	μs		

*: The oscillation time of the oscillator is the time it takes for the amplitude of the oscillations to reach 90%. For crystal oscillators, this time is between several ms and several tens of ms, for ceramic oscillators the time is between several hundred μs and several ms, and for an external clock, the time is 0 ms.

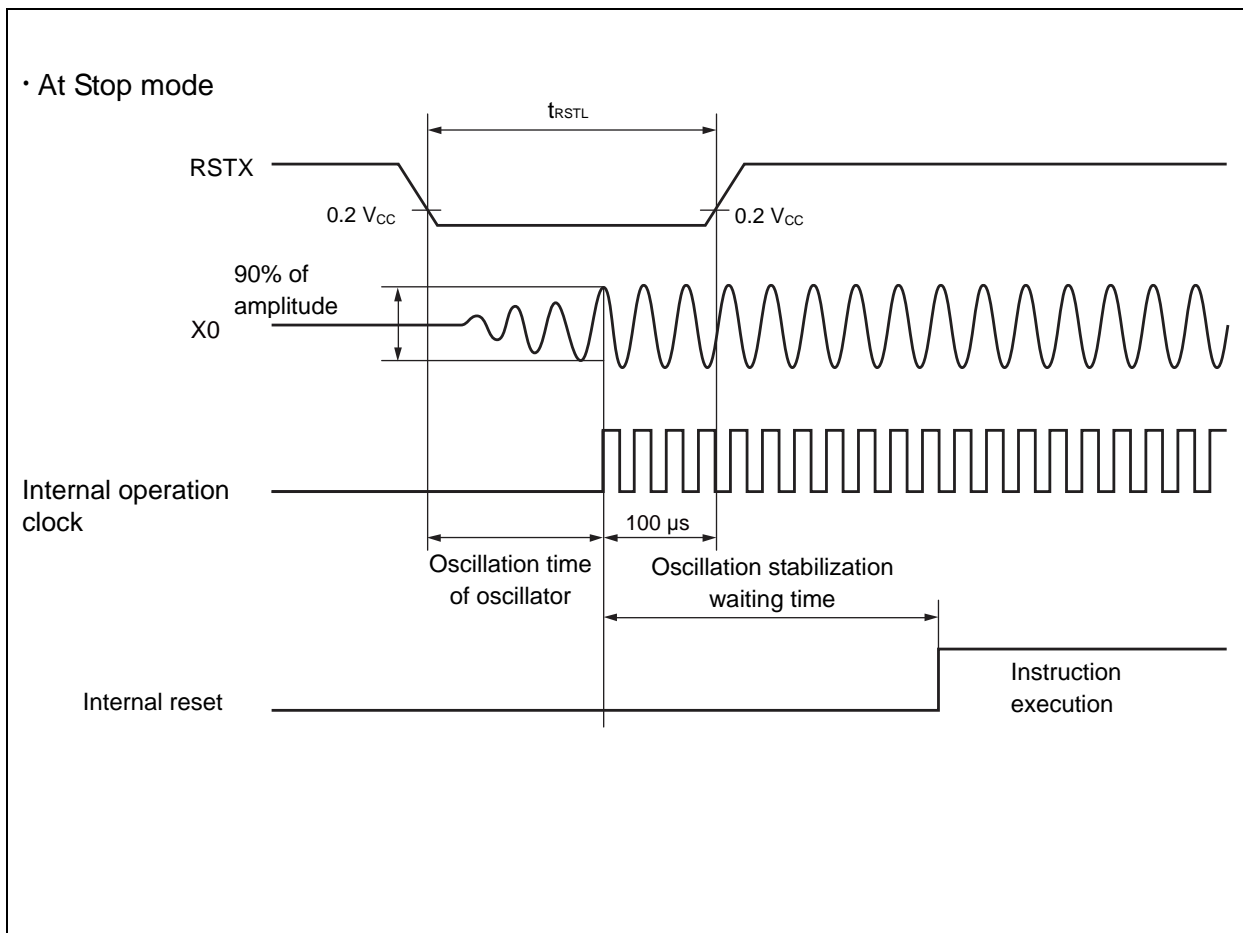
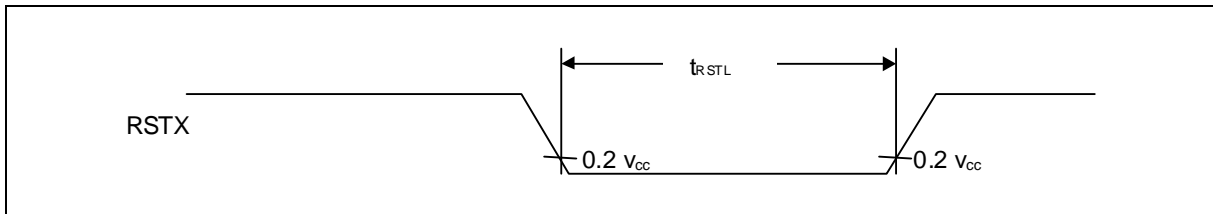

(3) Power-on Conditions

(T_A: -40°C to +125°C, V_{SS}=0.0V)

Parameter	Symbol	Pin name	Conditions	Value			Unit	Remarks
				Min	Typ	Max		
Level detection voltage	–	V _{CC}	–	2.024	2.2	2.376	V	
Level detection hysteresis width	–	V _{CC}	–	–	100	–	mV	
Level detection time	–	–	–	–	–	30	us	*1
Slope detection undetected standard	–	V _{CC}	V _{CC} = at level detection release level time	–	–	4	mV/μs	*2
Power off time	t _{OFF}	V _{CC}	–	50	–	–	ms	*3

*1: If the fluctuation of the power supply is faster than the low voltage detection time, there is the possibility to generate or release after the power supply voltage has exceeded the detection voltage range.

*2: When setting the power supply fluctuation to this standard or less, it is possible to suppress the slope detection. This is the standard when the power supply fluctuation is stable.

*3: This time is to start the slope detection at next power on after power down and internal charge loss.

MB91520 Series

(4) Multi-function Serial

(4-1) CSIO timing

(4-1-1) Bit setting: SMR: MD2=0, SMR: MD1=1, SMR : MD0=0, SMR: SCINV=0, SCR:SPI=0

(T_A: -40°C to +125°C, V_{CC}=AV_{CC}=5.0V ± 10%/V_{CC}=AV_{CC}=3.3V±0.3V, V_{SS}=AV_{SS}=0.0V)

Parameter	Symbol	Pin name	Condi- tions	Value		Unit	Remarks
				Min	Max		
Serial clock cycle time	t _{SCYC}	SCK0 to SCK11	-	4t _{CPP}	-	ns	Internal shift clock mode output pin : C _L =50pF
SCK ↓ → SOT delay time	t _{SLOVI}	SCK0 to SCK11 SOT0 to SOT11		-30	30	ns	
Valid SIN → SCK ↑ setup time	t _{IVSHI}	SCK0 to SCK11 SIN0 to SIN11		34	-	ns	
SCK ↑ → Valid SIN hold time	t _{SHIXI}			0	-	ns	
Serial clock "H" pulse width	t _{SHSL}	SCK0 to SCK11	-	t _{CPP} +10	-	ns	External shift clock mode output pin: C _L =50pF
Serial clock "L" pulse width	t _{SLSH}			2t _{CPP} -10	-	ns	
SCK ↓ → SOT delay time	t _{SLOVE}	SCK0 to SCK11 SOT0 to SOT11		-	33	ns	
Valid SIN → SCK ↑ setup time	t _{IVSHE}	SCK0 to SCK11 SIN0 to SIN11		10	-	ns	
SCK ↑ → Valid SIN hold time	t _{SHIXE}			20	-	ns	
SCK fall time	t _F	SCK0 to SCK2 SCK5 to SCK11		-	5	ns	
		SCK3 , SCK4		-	250		
SCK rise time	t _R	SCK0 to SCK11		-	5	ns	

Notes:

- AC characteristic in CLK synchronized mode.
- C_L is the load capacitance applied to pins during testing.
- The maximum baud rate is limited by internal operation clock used and other parameters. Please use ch.3 and ch.4 with maximum baud rate 400kbps or less.
See Hardware Manual for details.

• Internal shift clock mode

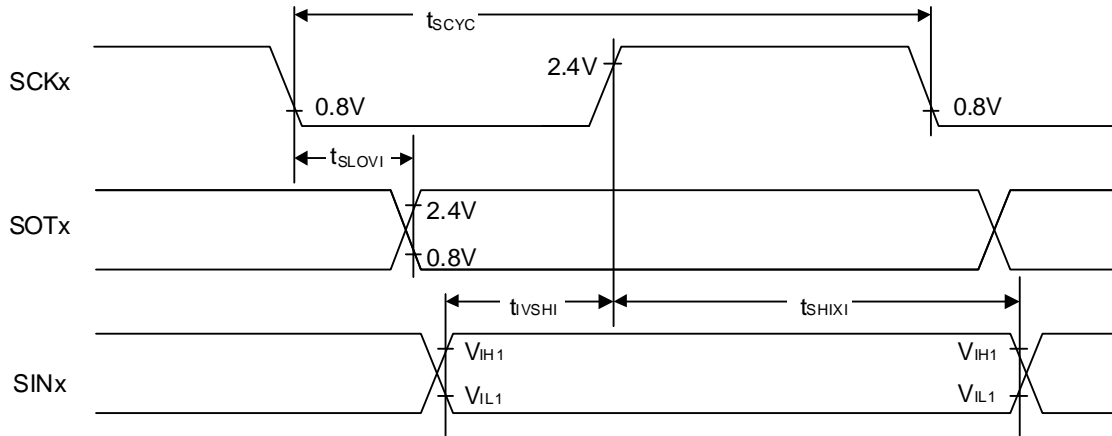

• External shift clock mode

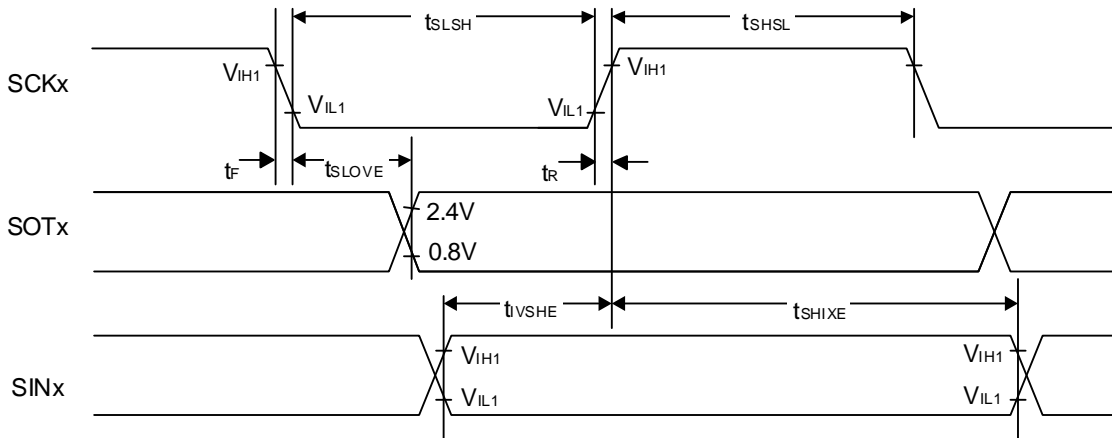

MB91520 Series

(4-1-2) Bit setting: SMR: MD2=0, SMR: MD1=1, SMR : MD0=0, SMR: SCINV=1, SCR:SPI=0

(T_A: -40°C to +125°C, V_{CC}=AV_{CC}=5.0V ± 10%/V_{CC}=AV_{CC}=3.3V±0.3V, V_{SS}=AV_{SS}=0.0V)

Parameter	Symbol	Pin name	Condi- tions	Value		Unit	Remarks
				Min	Max		
Serial clock cycle time	t _{SCYC}	SCK0 to SCK11	-	4t _{CPP}	-	ns	Internal shift clock mode output pin : C _L =50pF
SCK ↑ → SOT delay time	t _{SHOVI}	SCK0 to SCK11 SOT0 to SOT11		-30	30	ns	
Valid SIN → SCK ↓ setup time	t _{IVSLI}	SCK0 to SCK11 SIN0 to SIN11		34	-	ns	
SCK ↓ → Valid SIN hold time	t _{SLIXI}			0	-	ns	
Serial clock "H" pulse width	t _{SHSL}	SCK0 to SCK11	-	t _{CPP} +10	-	ns	External shift clock mode output pin: C _L =50pF
Serial clock "L" pulse width	t _{SLSH}			2t _{CPP} -10	-	ns	
SCK ↑ → SOT delay time	t _{SHOVE}	SCK0 to SCK11 SOT0 to SOT11		-	33	ns	
Valid SIN → SCK ↓ setup time	t _{IVSLE}	SCK0 to SCK11 SIN0 to SIN11		10	-	ns	
SCK ↓ → Valid SIN hold time	t _{SLIXE}			20	-	ns	
SCK fall time	t _F	SCK0 to SCK2 SCK5 to SCK11		-	5	ns	
		SCK3, SCK4		-	250		
SCK rise time	t _R	SCK0 to SCK11	-	5	ns		

Notes:

- AC characteristic in CLK synchronized mode.
- C_L is the load capacitance applied to pins during testing.
- The maximum baud rate is limited by internal operation clock used and other parameters. Please use ch.3 and ch.4 with maximum baud rate 400kbps or less.
See Hardware Manual for details.

• Internal shift clock mode

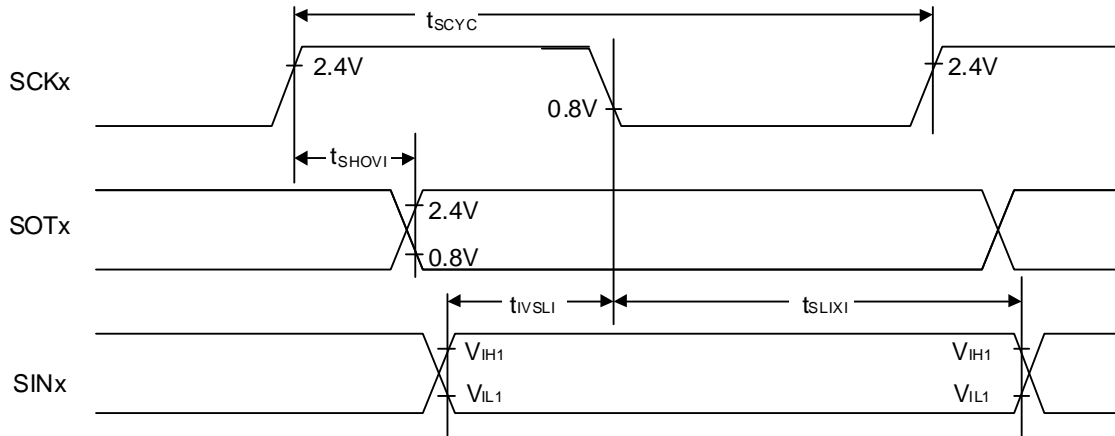

• External shift clock mode

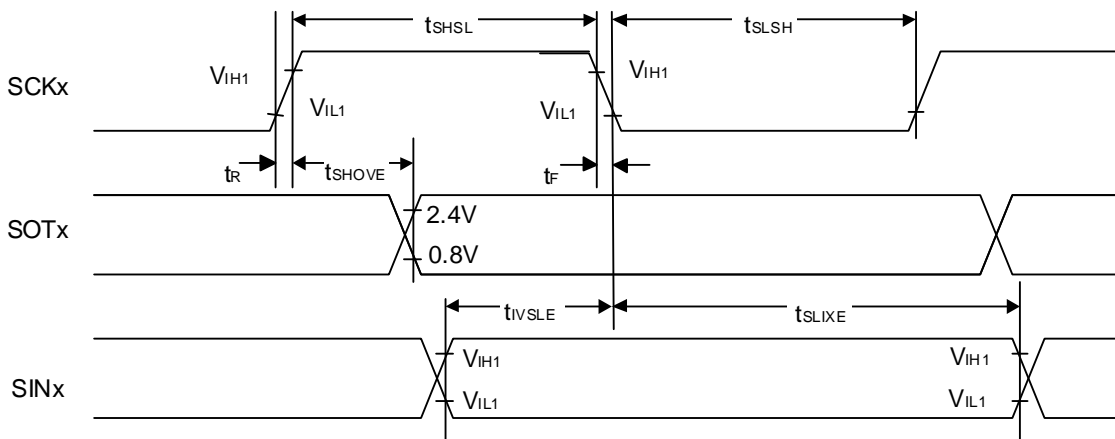

MB91520 Series

(4-1-3) Bit setting: SMR : MD2=0, SMR:MD1=1, SMR : MD0=0, SMR:SCINV=0, SCR:SPI=1

(T_A: -40°C to +125°C, V_{CC}=AV_{CC}=5.0V±10%/V_{CC}=AV_{CC}=3.3V±0.3V, V_{SS}=AV_{SS}=0.0V)

Parameter	Symbol	Pin name	Conditions	Value		Unit	Remarks
				Min	Max		
Serial clock cycle time	t _{SCYC}	SCK0 to SCK11	-	4t _{CPP}	-	ns	Internal shift clock mode output pin : C _L =50pF
SCK ↑ → SOT delay time	t _{SHOVI}	SCK0 to SCK11 SOT0 to SOT11		-30	30	ns	
Valid SIN → SCK ↓ setup time	t _{IVSLI}	SCK0 to SCK11 SIN0 to SIN11		34	-	ns	
SCK ↓ → Valid SIN hold time	t _{SLIXI}			0	-	ns	
SOT → SCK ↓ delay time	t _{SOVLI}	SCK0 to SCK11 SOT0 to SOT11		2t _{CPP} -30	-	ns	
Serial clock "H" pulse width	t _{SHSL}	SCK0 to SCK11	-	t _{CPP} +10	-	ns	External shift clock mode output pin : C _L =50pF
Serial clock "L" pulse width	t _{SLSH}			2t _{CPP} -10	-	ns	
SCK ↑ → SOT delay time	t _{SHOVE}	SCK0 to SCK11 SOT0 to SOT11		-	33	ns	
Valid SIN → SCK ↓ setup time	t _{IVSHE}	SCK0 to SCK11 SIN0 to SIN11		10	-	ns	
SCK ↓ → Valid SIN hold time	t _{SLIXE}			20	-	ns	
SCK fall time	t _F	SCK0 to SCK2, SCK5 to SCK11		-	5	ns	
		SCK3,SCK4		-	250		
SCK rise time	t _R	SCK0 to SCK11	-	5	ns		

Notes:

- AC characteristic in CLK synchronized mode.
- C_L is the load capacitance applied to pins during testing.
- The maximum baud rate is limited by internal operation clock used and other parameters. Please use ch.3 and ch.4 with maximum baud rate 400kbps or less.
See Hardware Manual for details.

• Internal shift clock mode

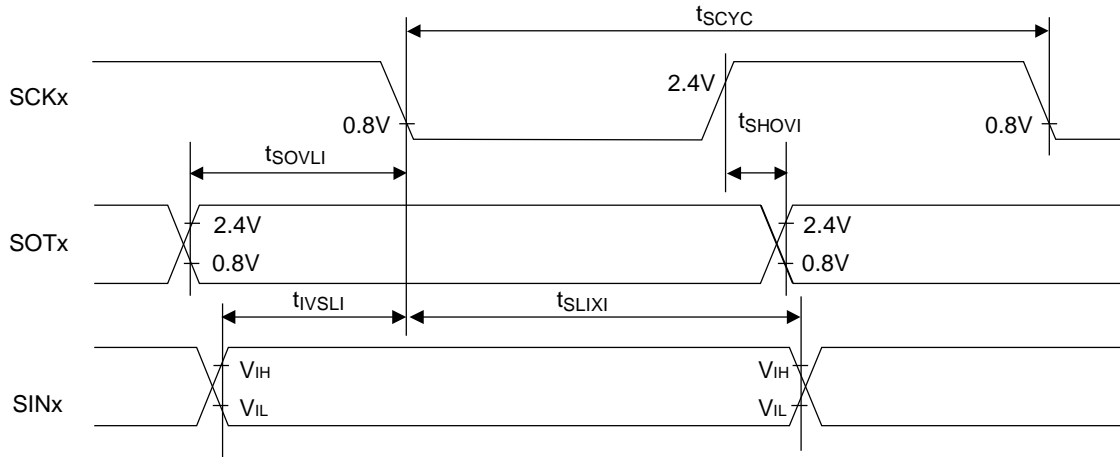

• External shift clock mode

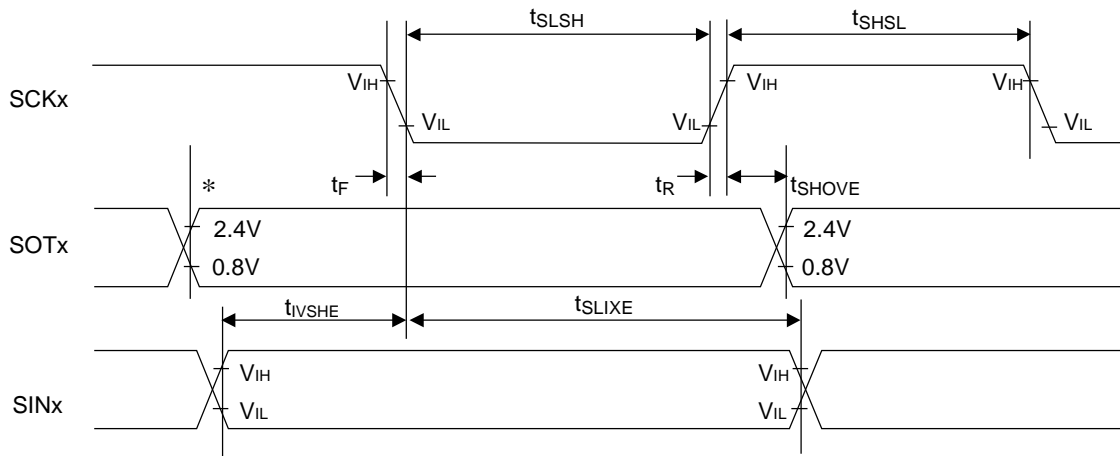

*: It writes in the TDR register and, then, it changes.

MB91520 Series

(4-1-4) Bit setting: SMR : MD2=0, SMR:MD1=1, SMR : MD0=0, SMR:SCINV=1, SCR:SPI=1

(T_A: -40°C to +125°C, V_{CC}=AV_{CC}=5.0V±10%/V_{CC}=AV_{CC}=3.3V±0.3V, V_{SS}=AV_{SS}=0.0V)

Parameter	Symbol	Pin name	Conditions	Value		Unit	Remarks
				Min	Max		
Serial clock cycle time	t _{SCYC}	SCK0 to SCK11	-	4t _{CPP}	-	ns	Internal shift clock mode output pin : C _L =50pF
SCK ↓ → SOT delay time	t _{SLOVI}	SCK0 to SCK11 SOT0 to SOT11		-30	30	ns	
Valid SIN → SCK ↑ setup time	t _{IVSHI}	SCK0 to SCK11 SIN0 to SIN11		34	-	ns	
SCK ↑ → Valid SIN hold time	t _{SHIXI}			0	-	ns	
SOT → SCK ↑ delay time	t _{SOVHI}	SCK0 to SCK11 SOT0 to SOT11		2t _{CPP} -30	-	ns	
Serial clock "H" pulse width	t _{SHSL}	SCK0 to SCK11	-	t _{CPP} +10	-	ns	External shift clock mode output pin : C _L =50pF
Serial clock "L" pulse width	t _{SLSH}			2t _{CPP} -10	-	ns	
SCK ↓ → SOT delay time	t _{SLOVE}	SCK0 to SCK11 SOT0 to SOT11		-	33	ns	
Valid SIN → SCK ↑ setup time	t _{IVSHE}	SCK0 to SCK11 SIN0 to SIN11		10	-	ns	
SCK ↑ → Valid SIN hold time	t _{SHIXE}			20	-	ns	
SCK fall time	t _F	SCK0 to SCK2, SCK5 to SCK11		-	5	ns	
		SCK3,SCK4		-	250		
SCK rise time	t _R	SCK0 to SCK11	-	5	ns		

Notes:

- AC characteristic in CLK synchronized mode.
- C_L is the load capacitance applied to pins during testing.
- The maximum baud rate is limited by internal operation clock used and other parameters. Please use ch.3 and ch.4 with maximum baud rate 400kbps or less.
See Hardware Manual for details.

• Internal shift clock mode

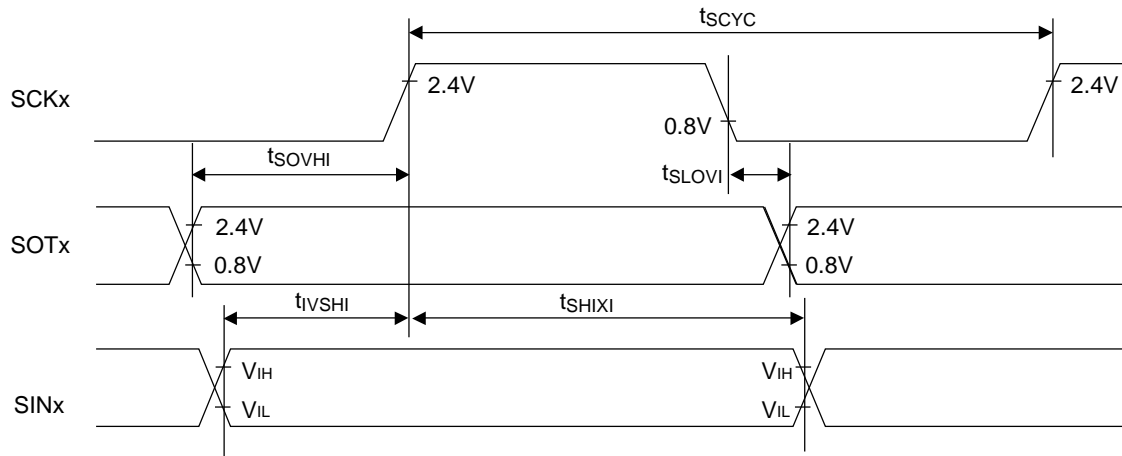

• External shift clock mode

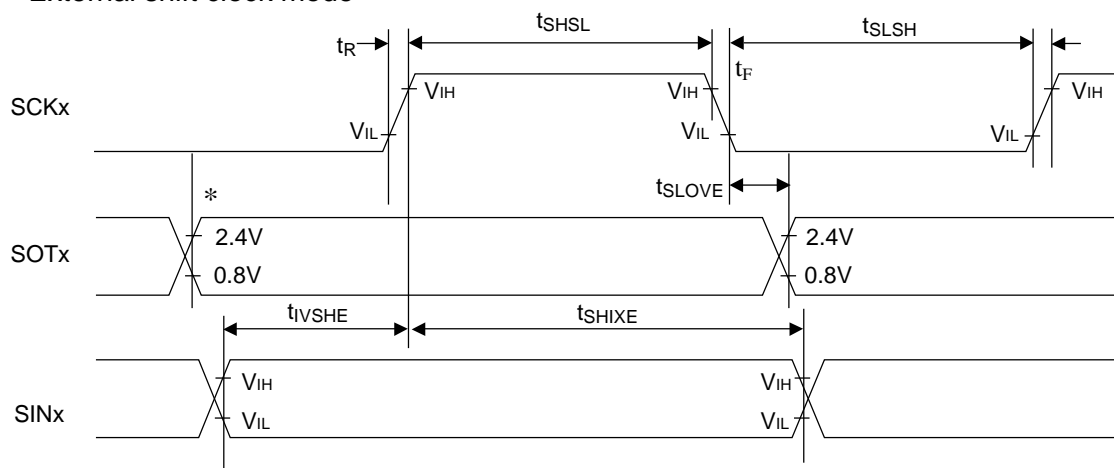

*: It writes in the TDR register and, then, it changes.

MB91520 Series

(4-1-5) Bit setting: SMR:MD2=0, SMR:MD1=1, SMR:MD0=0,

When Serial chip select is used : SCSCR:CSEN=1,

Serial clock output mark level "H" : SMR,SCSFR:SCINV=0,

Serial chip select Inactive level "H" : SCSCR,SCSFR:CSLVL=1

(T_A: -40°C to +125°C, V_{CC}=AV_{CC}=5.0V±10%/V_{CC}=AV_{CC}=3.3V±0.3V, V_{SS}=AV_{SS}=0.0V)

Parameter	Symbol	Pin name	Conditions	Value		Unit	Remarks
				Min	Max		
SCS ↓ → SCK ↓ setup time	t _{CSSU}	SCK1 to SCK11, SCS1 to SCS3, SCS40 to SCS43, SCS50 to SCS53,	-	t _{CSSU} +0 *1	t _{CSSU} +50 *1	ns	Internal shift clock mode output pin : C _L =50pF
SCK ↑ → SCS ↑ hold time	t _{CSDI}	SCS1 to SCS3, SCS40 to SCS43, SCS50 to SCS53, SCS60 to SCS63, SCS70 to SCS73, SCS8 to SCS11		t _{CSDI} -50 *2	t _{CSDI} +0 *2	ns	
SCS deselect time	t _{CSDI}	SCS1 to SCS3, SCS40 to SCS43, SCS50 to SCS53, SCS60 to SCS63, SCS70 to SCS73, SCS8 to SCS11		t _{CSDI} -50 *3	t _{CSDI} +50 *3	ns	
SCS ↓ → SCK ↓ setup time	t _{CSSE}	SCK1 to SCK11, SCS1 to SCS3, SCS40 to SCS43, SCS50 to SCS53,	-	3t _{CPP} +30	-	ns	External shift clock mode output pin: C _L =50pF
SCK ↑ → SCS ↑ hold time	t _{CSHE}	SCS1 to SCS3, SCS40 to SCS43, SCS50 to SCS53, SCS60 to SCS63, SCS70 to SCS73, SCS8 to SCS11		+0	-	ns	
SCS deselect time	t _{CSDE}	SCS1 to SCS3, SCS40 to SCS43, SCS50 to SCS53, SCS60 to SCS63, SCS70 to SCS73, SCS8 to SCS11		3t _{CPP} +30	-	ns	
SCS ↓ → SOT delay time	t _{DSE}	SCS1 to SCS3, SCS40 to SCS43, SCS50 to SCS53, SCS60 to SCS63,	-	-	40	ns	
SCS ↑ → SOT delay time	t _{DEE}	SCS70 to SCS73, SCS8 to SCS11, SOT1 to SOT11		+0	-	ns	
SCK ↓ → SCS ↓ clock switch time	t _{SCC}	SCK1 to SCK11, SCS1 to SCS3, SCS40 to SCS43, SCS50 to SCS53, SCS60 to SCS63, SCS70 to SCS73, SCS8 to SCS11	-	3t _{CPP} +0	3t _{CPP} +50	ns	Internal shift clock mode Round operation output pin: C _L =50pF

*1: t_{CSSU} = SCSTR:CSSU7-0 × Serial chip select timing operating clock

*2: t_{CSDI} = SCSTR:CSHD7-0 × Serial chip select timing operating clock

*3: t_{CSDS} = SCSTR:CSDS15-0 × Serial chip select timing operating clock

Please see the hardware manual for details of above-mentioned *1, *2, and *3.

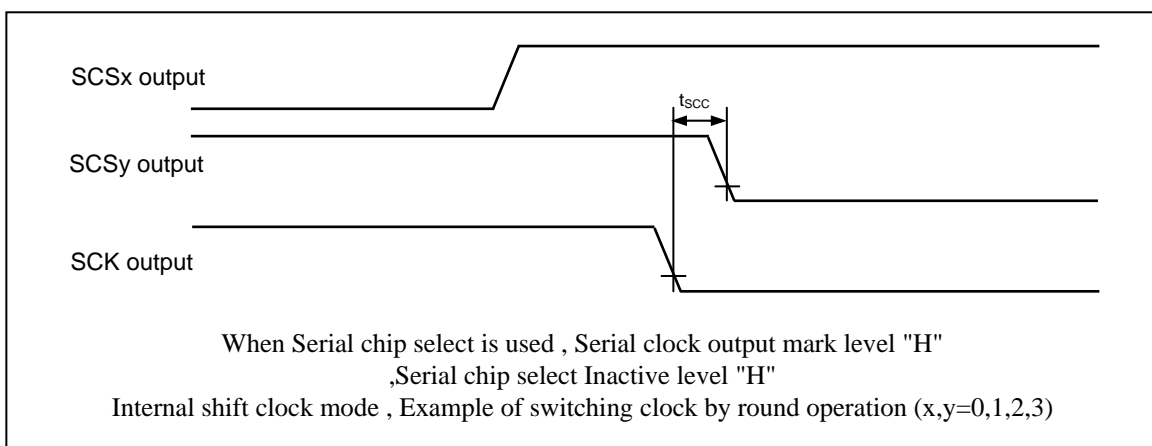
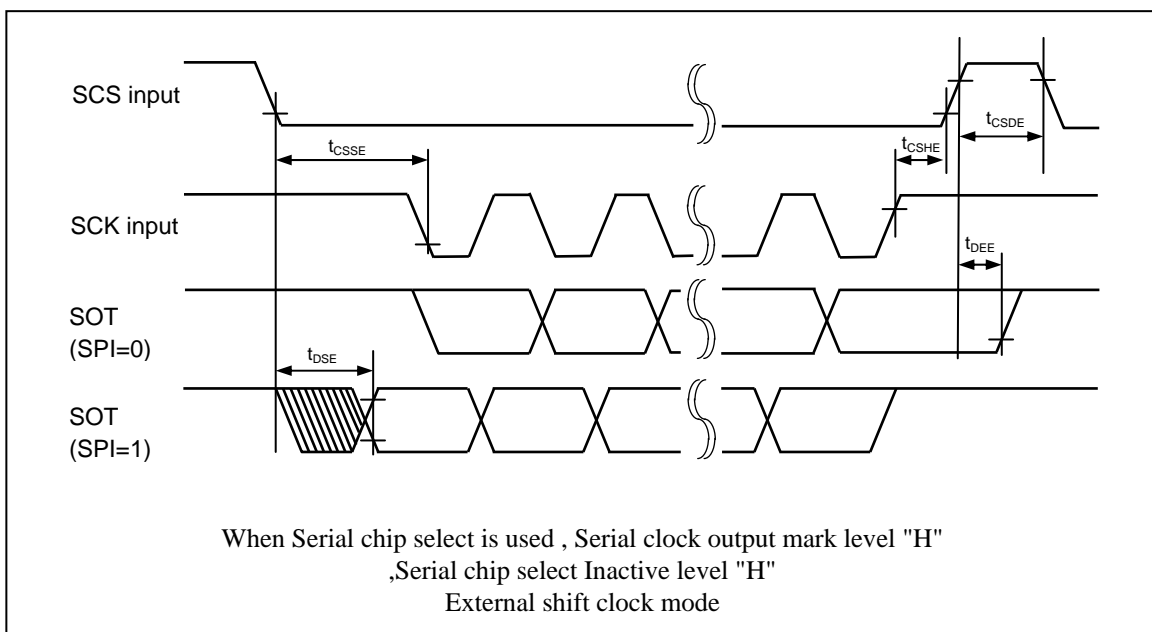
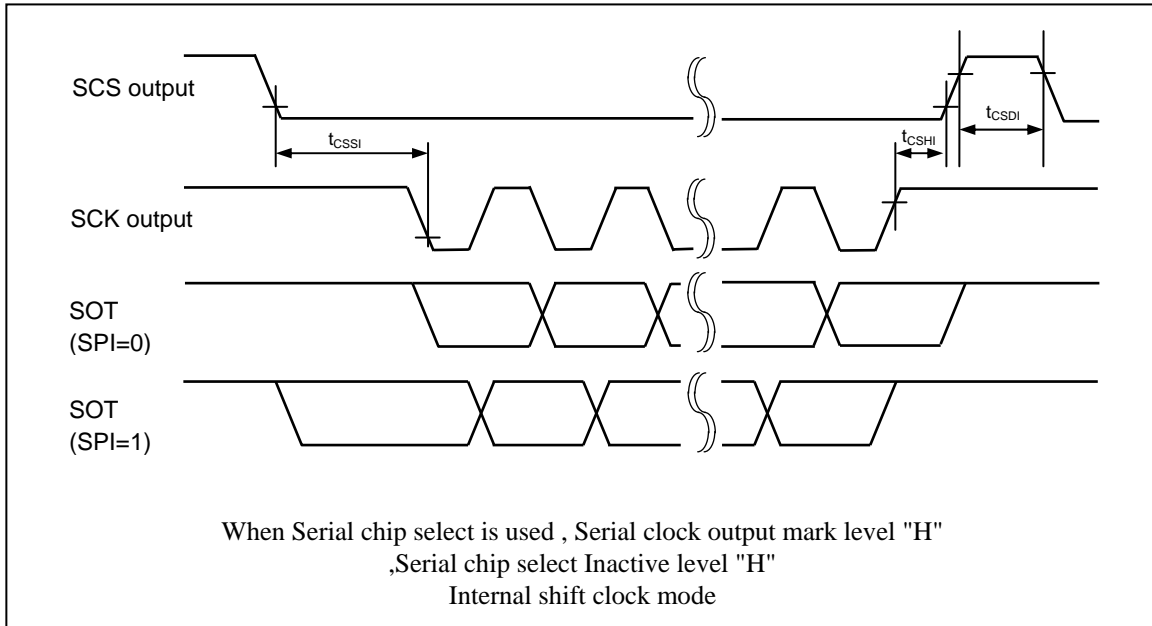

MB91520 Series

(4-1-6) Bit setting: SMR:MD2=0, SMR:MD1=1, SMR:MD0=0,
 When Serial chip select is used : SCSCR:CSEN=1,
 Serial clock output mark level "L" : SMR,SCSFR:SCINV=1,
 Serial chip select Inactive level "H" : SCSCR,SCSFR:CSLVL=1

(T_A: -40°C to +125°C, V_{CC}=AV_{CC}=5.0V±10%/V_{CC}=AV_{CC}=3.3V±0.3V, V_{SS}=AV_{SS}=0.0V)

Parameter	Symbol	Pin name	Conditions	Value		Unit	Remarks
				Min	Max		
SCS ↓ → SCK ↑ setup time	t _{CSSU}	SCK1 to SCK11, SCS1 to SCS3, SCS40 to SCS43, SCS50 to SCS53,	-	t _{CSSU} +0 *1	t _{CSSU} +50 *1	ns	Internal shift clock mode output pin : C _L =50pF
SCK ↓ → SCS ↑ hold time	t _{CSDH}	SCS60 to SCS63, SCS70 to SCS73, SCS8 to SCS11		t _{CSDH} -50 *2	t _{CSDH} +0 *2	ns	
SCS deselect time	t _{CSDI}	SCS1 to SCS3, SCS40 to SCS43, SCS50 to SCS53, SCS60 to SCS63, SCS70 to SCS73, SCS8 to SCS11		t _{CSDS} -50 *3	t _{CSDS} +50 *3	ns	
SCS ↓ → SCK ↑ setup time	t _{CSSE}	SCK1 to SCK11, SCS1 to SCS3, SCS40 to SCS43, SCS50 to SCS53,	-	3t _{CPP} +30	-	ns	External shift clock mode output pin: C _L =50pF
SCK ↓ → SCS ↑ hold time	t _{CSHE}	SCS60 to SCS63, SCS70 to SCS73, SCS8 to SCS11		+0	-	ns	
SCS deselect time	t _{CSDE}	SCS1 to SCS3, SCS40 to SCS43, SCS50 to SCS53, SCS60 to SCS63, SCS70 to SCS73, SCS8 to SCS11		3t _{CPP} +30	-	ns	
SCS ↓ → SOT delay time	t _{DSE}	SCS1 to SCS3, SCS40 to SCS43, SCS50 to SCS53, SCS60 to SCS63,	-	-	40	ns	
SCS ↑ → SOT delay time	t _{DEE}	SCS70 to SCS73, SCS8 to SCS11, SOT1 to SOT11		+0	-	ns	
SCK ↑ → SCS ↓ clock switch time	t _{SCC}	SCK1 to SCK11, SCS1 to SCS3, SCS40 to SCS43, SCS50 to SCS53, SCS60 to SCS63, SCS70 to SCS73, SCS8 to SCS11	-	3t _{CPP} +0	3t _{CPP} +50	ns	Internal shift clock mode Round operation output pin: C _L =50pF

*1: t_{CSSU} = SCSTR:CSSU7-0 × Serial chip select timing operating clock

*2: t_{CSDH} = SCSTR:CSHD7-0 × Serial chip select timing operating clock

*3: t_{CSDS} = SCSTR:CSDS15-0 × Serial chip select timing operating clock

Please see the hardware manual for details of above-mentioned *1, *2, and *3

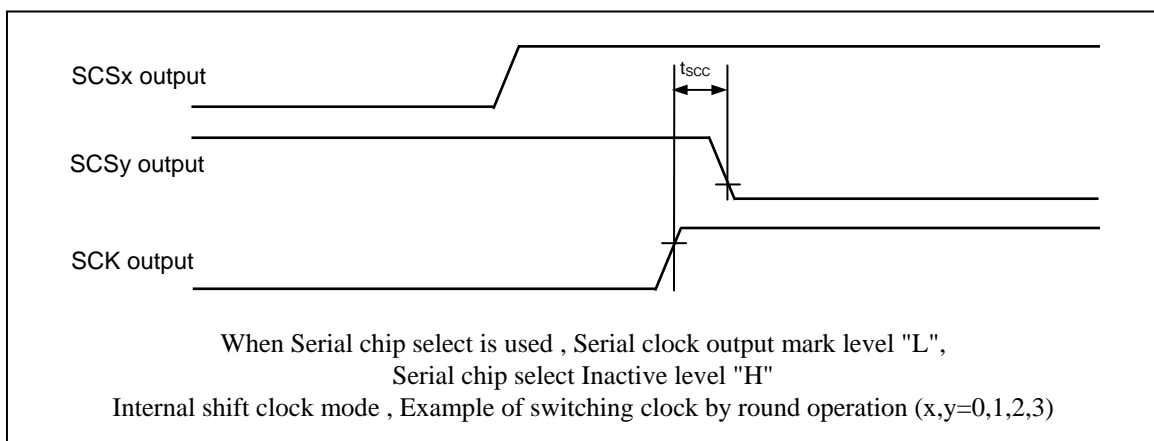
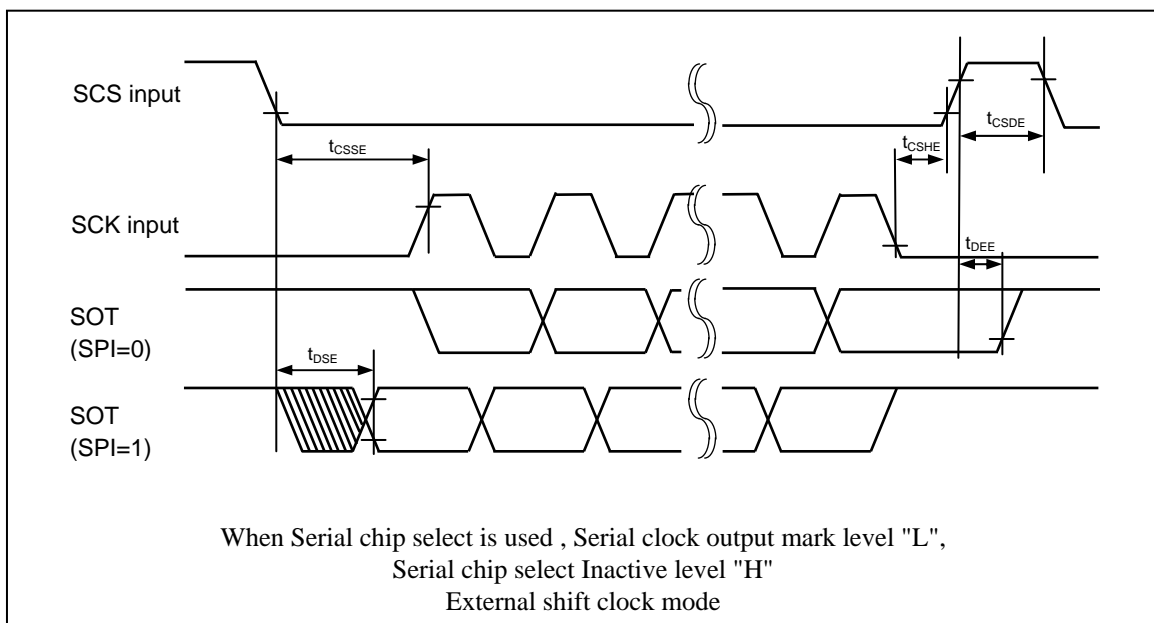
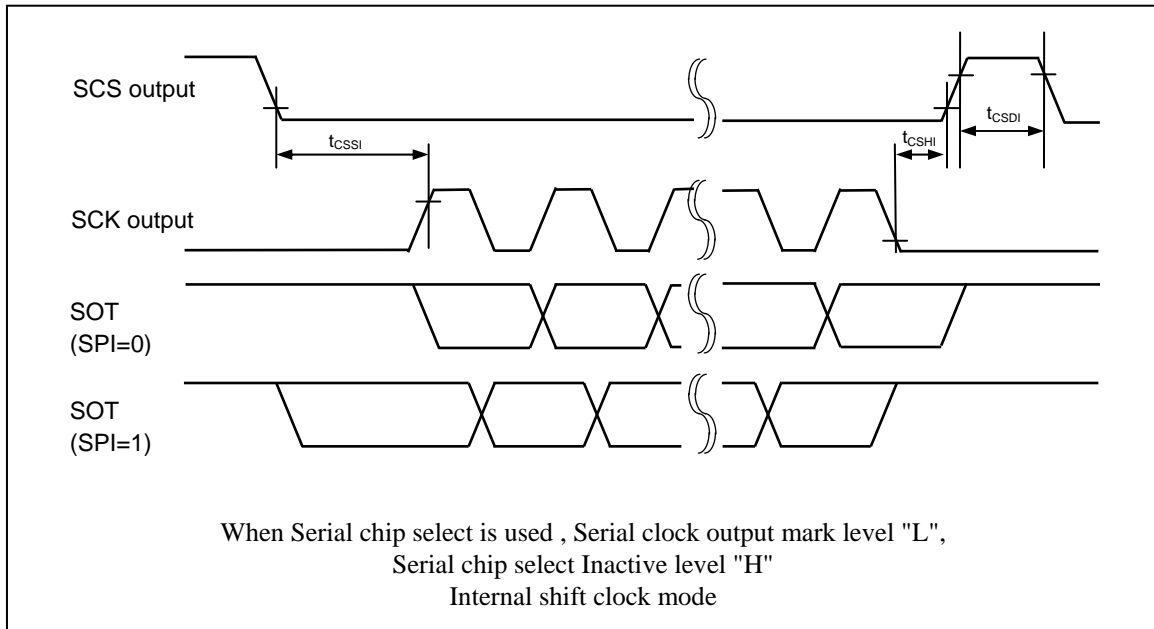

MB91520 Series

(4-1-7) Bit setting: SMR:MD2=0, SMR:MD1=1, SMR:MD0=0,
 When Serial chip select is used : SCSCR:CSEN=1,
 Serial clock output mark level "H" : SMR,SCSFR:SCINV=0,
 Serial chip select Inactive level "L" : SCSCR,SCSFR:CSLVL=0

(T_A: -40°C to +125°C, V_{CC}=AV_{CC}=5.0V±10%/V_{CC}=AV_{CC}=3.3V±0.3V, V_{SS}=AV_{SS}=0.0V)

Parameter	Symbol	Pin name	Conditions	Value		Unit	Remarks
				Min	Max		
SCS ↑ → SCK ↓ setup time	t _{CSSU}	SCK1 to SCK11, SCS1 to SCS3, SCS40 to SCS43, SCS50 to SCS53,	-	t _{CSSU} +0 *1	t _{CSSU} +50 *1	ns	Internal shift clock mode output pin : C _L =50pF
SCK ↑ → SCS ↓ hold time	t _{CSDH}	SCS60 to SCS63, SCS70 to SCS73, SCS8 to SCS11		t _{CSDH} -50 *2	t _{CSDH} +0 *2	ns	
SCS deselect time	t _{CSDI}	SCS1 to SCS3, SCS40 to SCS43, SCS50 to SCS53, SCS60 to SCS63, SCS70 to SCS73, SCS8 to SCS11		t _{CSDS} -50 *3	t _{CSDS} +50 *3	ns	
SCS ↑ → SCK ↓ setup time	t _{CSSE}	SCK1 to SCK11, SCS1 to SCS3, SCS40 to SCS43, SCS50 to SCS53,	-	3t _{CPP} +30	-	ns	External shift clock mode output pin: C _L =50pF
SCK ↑ → SCS ↓ hold time	t _{CSHE}	SCS60 to SCS63, SCS70 to SCS73, SCS8 to SCS11		+0	-	ns	
SCS deselect time	t _{CSDE}	SCS1 to SCS3, SCS40 to SCS43, SCS50 to SCS53, SCS60 to SCS63, SCS70 to SCS73, SCS8 to SCS11		3t _{CPP} +30	-	ns	
SCS ↑ → SOT delay time	t _{DSE}	SCS1 to SCS3, SCS40 to SCS43, SCS50 to SCS53, SCS60 to SCS63,		-	40	ns	
SCS ↓ → SOT delay time	t _{DEE}	SCS70 to SCS73, SCS8 to SCS11, SOT1 to SOT11		+0	-	ns	
SCK ↓ → SCS ↑ clock switch time	t _{SCC}	SCK1 to SCK11, SCS1 to SCS3, SCS40 to SCS43, SCS50 to SCS53, SCS60 to SCS63, SCS70 to SCS73, SCS8 to SCS11	-	3t _{CPP} +0	3t _{CPP} +50	ns	Internal shift clock mode Round operation output pin: C _L =50pF

*1: t_{CSSU} = SCSTR:CSSU7-0 × Serial chip select timing operating clock

*2: t_{CSDH} = SCSTR:CSHD7-0 × Serial chip select timing operating clock

*3: t_{CSDS} = SCSTR:CSDS15-0 × Serial chip select timing operating clock

Please see the hardware manual for details of above-mentioned *1, *2, and *3.

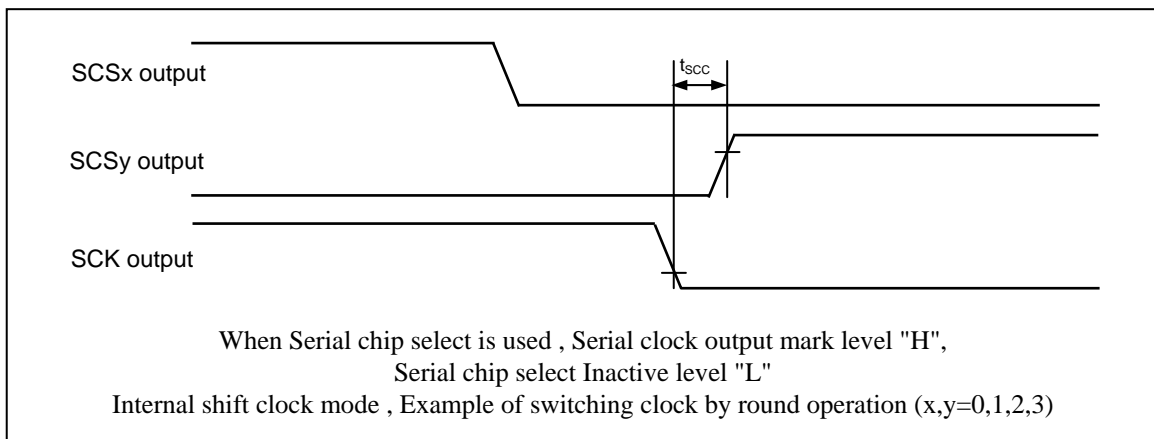
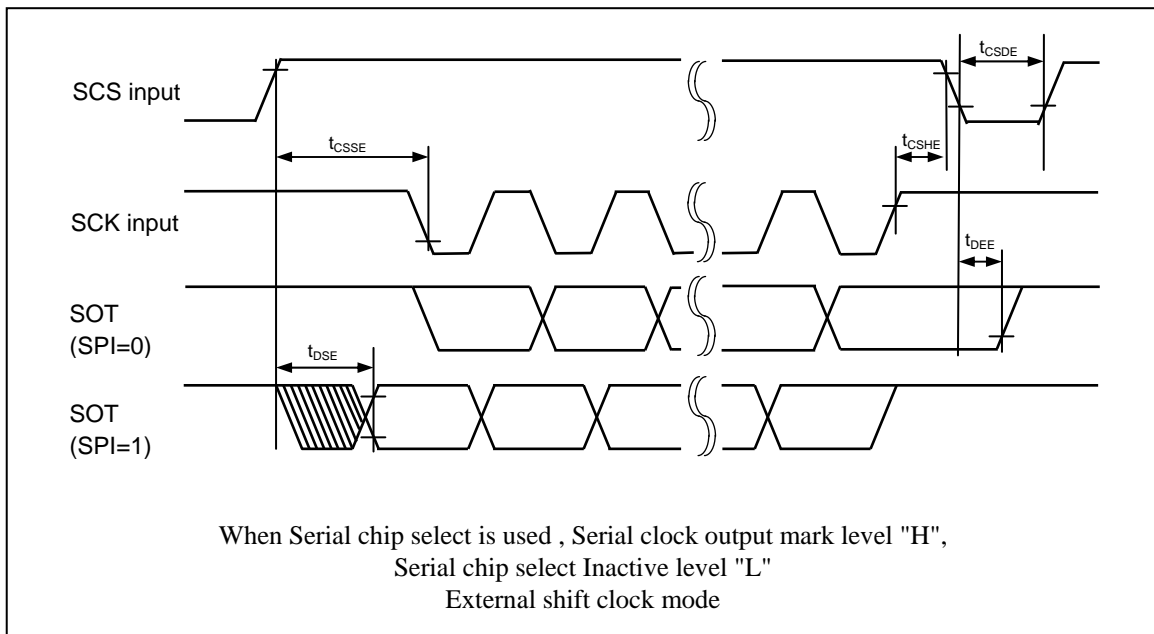
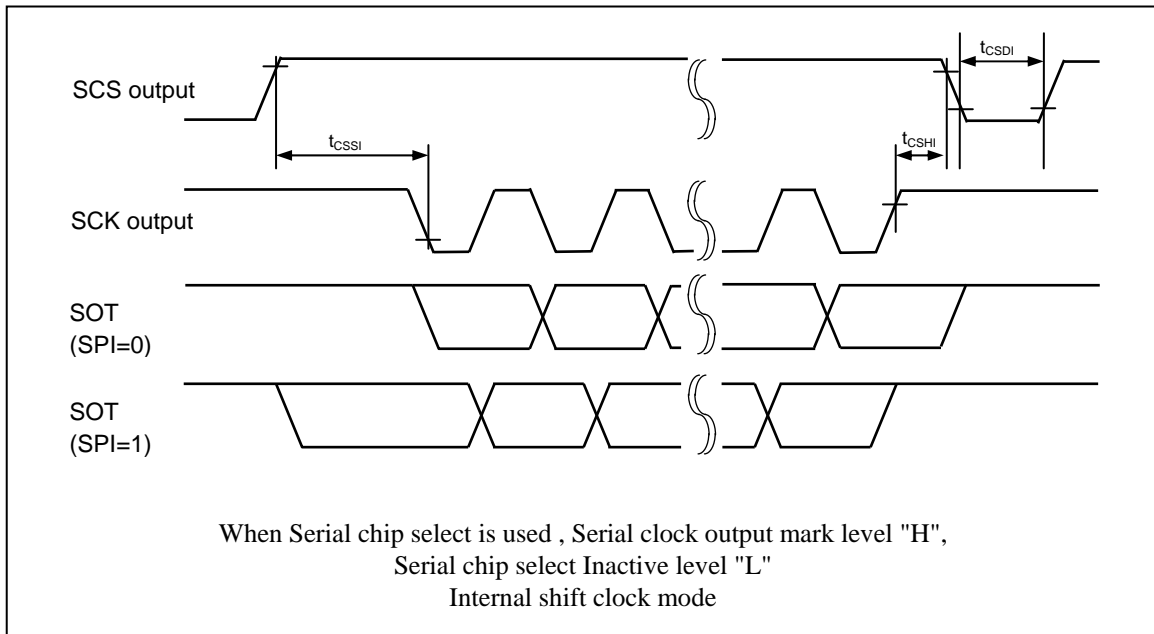

MB91520 Series

(4-1-8) Bit setting: SMR:MD2=0, SMR:MD1=1, SMR:MD0=0,
 When Serial chip select is used: SCSCR:CSSEN=1,
 Serial clock output mark level "L" : SMR,SCSFR:SCINV=1,
 Serial chip select Inactive level "L" : SCSCR,SCSFR:CSLVL=0

(T_A: -40°C to +125°C, V_{CC}=AV_{CC}=5.0V±10%/V_{CC}=AV_{CC}=3.3V±0.3V, V_{SS}=AV_{SS}=0.0V)

Parameter	Symbol	Pin name	Conditions	Value		Unit	Remarks
				Min	Max		
SCS ↑ → SCK ↑ setup time	t _{CSSU}	SCK1 to SCK11, SCS1 to SCS3, SCS40 to SCS43, SCS50 to SCS53,	-	t _{CSSU} +0 *1	t _{CSSU} +50 *1	ns	Internal shift clock mode output pin : C _L =50pF
SCK ↓ → SCS ↓ hold time	t _{CSDH}	SCS60 to SCS63, SCS70 to SCS73, SCS8 to SCS11		t _{CSDH} -50 *2	t _{CSDH} +0 *2	ns	
SCS deselect time	t _{CSDI}	SCS1 to SCS3, SCS40 to SCS43, SCS50 to SCS53, SCS60 to SCS63, SCS70 to SCS73, SCS8 to SCS11		t _{CSDS} -50 *3	t _{CSDS} +50 *3	ns	
SCS ↑ → SCK ↑ setup time	t _{CSSE}	SCK1 to SCK11, SCS1 to SCS3, SCS40 to SCS43, SCS50 to SCS53,	-	3t _{CPP} +30	-	ns	External shift clock mode output pin: C _L =50pF
SCK ↓ → SCS ↓ hold time	t _{CSHE}	SCS60 to SCS63, SCS70 to SCS73, SCS8 to SCS11		+0	-	ns	
SCS deselect time	t _{CSDE}	SCS1 to SCS3, SCS40 to SCS43, SCS50 to SCS53, SCS60 to SCS63, SCS70 to SCS73, SCS8 to SCS11		3t _{CPP} +30	-	ns	
SCS ↑ → SOT delay time	t _{DSE}	SCS1 to SCS3, SCS40 to SCS43, SCS50 to SCS53,	-	-	40	ns	
SCS ↓ → SOT delay time	t _{DEE}	SCS60 to SCS63, SCS70 to SCS73, SCS8 to SCS11, SOT1 to SOT11		+0	-	ns	
SCK ↑ → SCS ↑ clock switch time	t _{SCC}	SCK1 to SCK11, SCS1 to SCS3, SCS40 to SCS43, SCS50 to SCS53, SCS60 to SCS63, SCS70 to SCS73, SCS8 to SCS11	-	3t _{CPP} +0	3t _{CPP} +50	ns	Internal shift clock mode Round operation output pin: C _L =50pF

*1: t_{CSSU} = SCSTR:CSSU7-0 × Serial chip select timing operating clock

*2: t_{CSDH} = SCSTR:CSHD7-0 × Serial chip select timing operating clock

*3: t_{CSDS} = SCSTR:CSDS15-0 × Serial chip select timing operating clock

Please see the hardware manual for details of above-mentioned *1, *2, and *3.

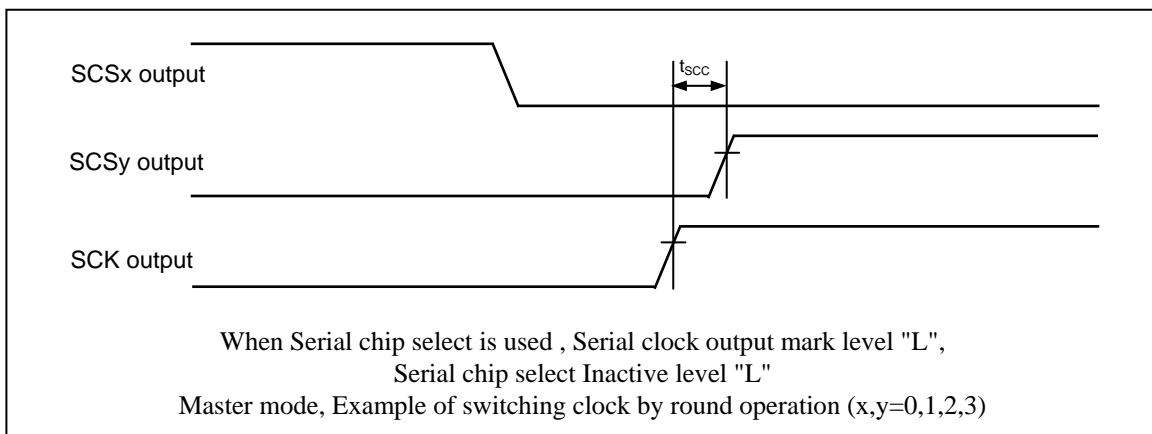
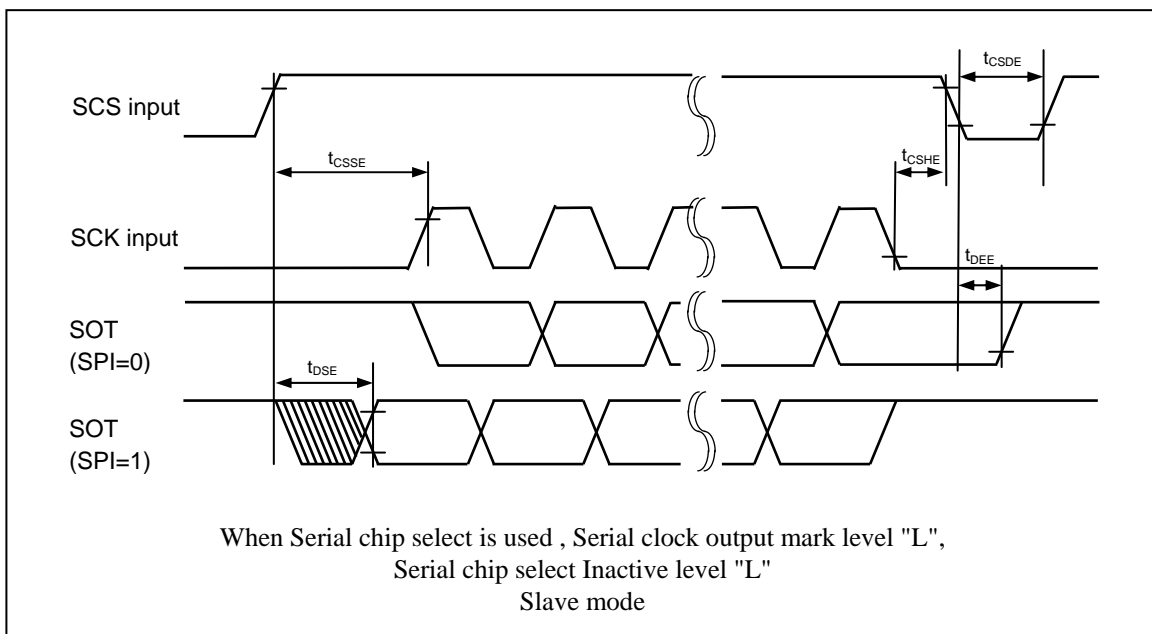
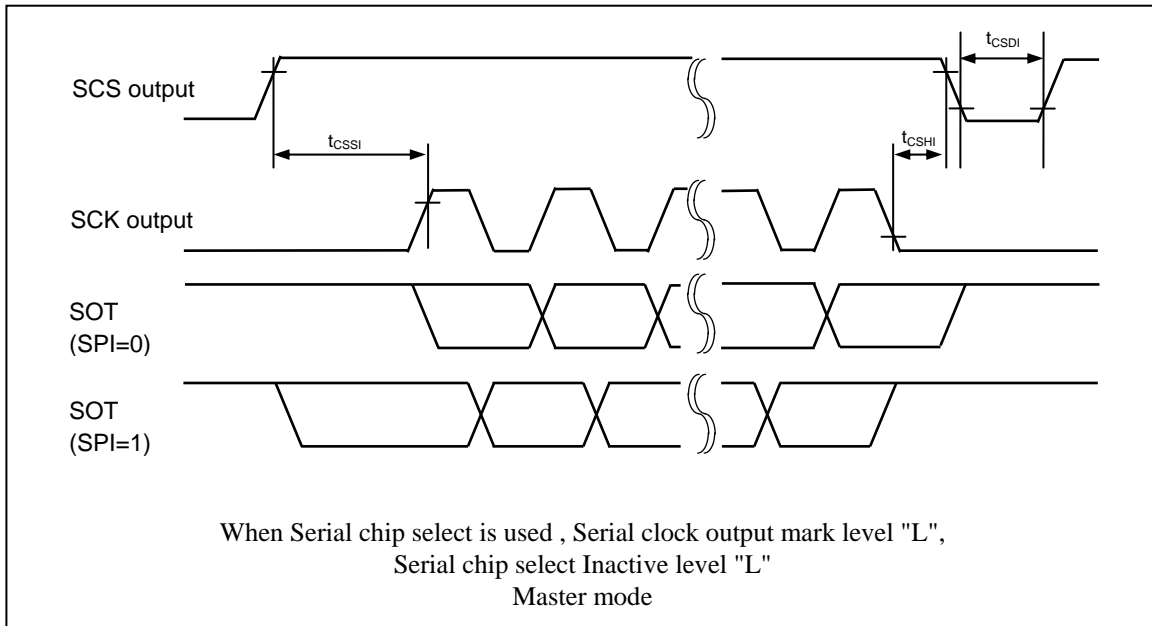

MB91520 Series

(4-2) UART (Asynchronous serial interface) timing

Bit setting: SMR : MD2=0, SMR:MD1=0, SMR : MD0=0

Bit setting: SMR : MD2=0, SMR:MD1=0, SMR : MD0=1

When external clock is selected (BGR:EXT=1)

(T_A : -40°C to +125°C, $V_{CC}=AV_{CC}=5.0V\pm 10\%/V_{CC}=AV_{CC}=3.3V\pm 0.3V, V_{SS}=AV_{SS}=0.0V$)

Parameter	Symbol	Pin name	Conditions	Value		Unit	Remarks
				Min	Max		
Serial clock "L" pulse width	t_{SLSH}	SCK0 to SCK11	-	$t_{CPP}+10$	-	ns	output pin: $C_L=50pF$
Serial clock "H" pulse width	t_{SHSL}			$t_{CPP}+10$	-	ns	
SCK fall time	t_F			-	5	ns	
SCK rise time	t_R			-	5	ns	

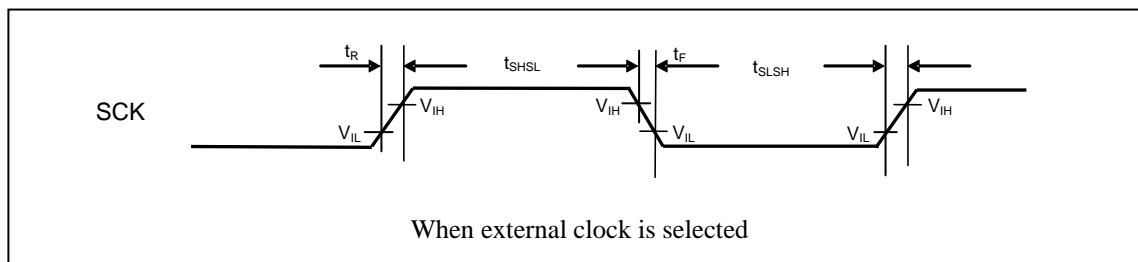

(4-3) LIN Interface (v2.1)(Asynchronous Serial Interface for LIN (v2.1)) timing

Bit setting: SMR : MD2=0, SMR:MD1=1, SMR : MD0=1

(T_A : -40°C to +125°C, $V_{CC}=AV_{CC}=5.0V\pm 10\%/V_{CC}=AV_{CC}=3.3V\pm 0.3V, V_{SS}=AV_{SS}=0.0V$)

Parameter	Symbol	Pin name	Conditions	Value		Unit	Remarks
				Min	Max		
Serial clock "L" pulse width	t_{SLSH}	SCK0 to SCK11	-	$t_{CPP}+10$	-	ns	output pin: $C_L=50pF$
Serial clock "H" pulse width	t_{SHSL}			$t_{CPP}+10$	-	ns	
SCK fall time	t_F			-	5	ns	
SCK rise time	t_R			-	5	ns	

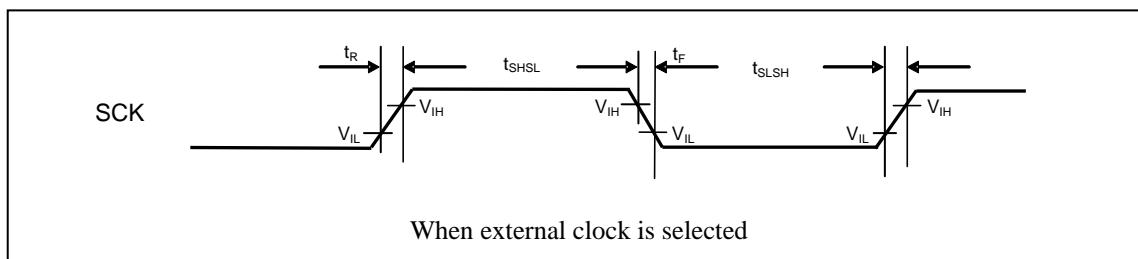

(4-4) I²C timing

(T_A: -40°C to +125°C, V_{CC}=AV_{CC}=5.0V ± 10%/V_{CC}=AV_{CC}=3.3V±0.3V, V_{SS}=AV_{SS}=0.0V)

Parameter	Symbol	Pin name	Conditions	Standard mode		High-speed mode* ³		Unit	Remarks
				Min	Max	Min	Max		
SCL clock frequency	f _{SCL}	SCK3 to SCK11	C _L =50pF R = (V _P /I _{OL}) * ¹	0	100	0	400	kHz	
Repeat "start" condition hold time SDA ↓ → SCL ↓	t _{HDSTA}	SOT3 to SOT11, (SDA) SCK3 to SCK11, (SCL)		4.0	–	0.6	–	μs	
Period of "L" for SCL clock	t _{LOW}	SCK3 to SCK11, (SCL)		4.7	–	1.3	–	μs	
Period of "H" for SCL clock	t _{HIGH}	SCK3 to SCK11, (SCL)		4.0	–	0.6	–	μs	
Repeat "start" condition setup time SCL ↑ → SDA ↓	t _{SUSTA}	SCK3 to SCK11, (SCL)		4.7	–	0.6	–	μs	
Data hold time SCL ↓ → SDA ↓ ↑	t _{HDDAT}	SOT3 to SOT11, (SDA) SCK3 to SCK11, (SCL)		0	3.45* ²	0	0.9* ³	μs	
Data setup time SDA ↓ ↑ → SCL ↑	t _{SUDAT}	SOT3 to SOT11, (SDA) SCK3 to SCK11, (SCL)		250	–	100	–	ns	
"Stop" condition setup time SCL ↑ → SDA ↑	t _{SUSTO}	SOT3 to SOT11, (SDA) SCK3 to SCK11, (SCL)		4.0	–	0.6	–	μs	
Bus-free time between "stop" condition and "start" condition	t _{BUF}	–		4.7	–	1.3	–	μs	
Noise filter	t _{SP}	–	–	2t _{CPP} * ⁴	–	2t _{CPP} * ⁴	–	ns	

Notes: Only ch.3 and ch.4 are standard mode/high-speed mode correspondence. In ch.5-ch.8, ch.10, and ch.11, only a standard mode is correspondences.

*1: R and C_L represent the pull-up resistance and load capacitance of the SCL and SDA output lines, respectively.

V_p shows that the power-supply voltage of the pull-up resistor and I_{OL} shows the V_{OL} guarantee current.

*2: The maximum t_{HDDAT} only has to be met if the device does not extend the "L" width (t_{LOW}) of the SCL signal.

*3: A high-speed mode I²C bus device can be used on a standard mode I²C bus system as long as the device satisfies the requirement of "t_{SUDAT} ≥ 250 ns".

*4: t_{CPP} is the peripheral clock cycle time. Adjust the clock of the bus in the surrounding to 8MHz or more when use I²C.

• I²C timing

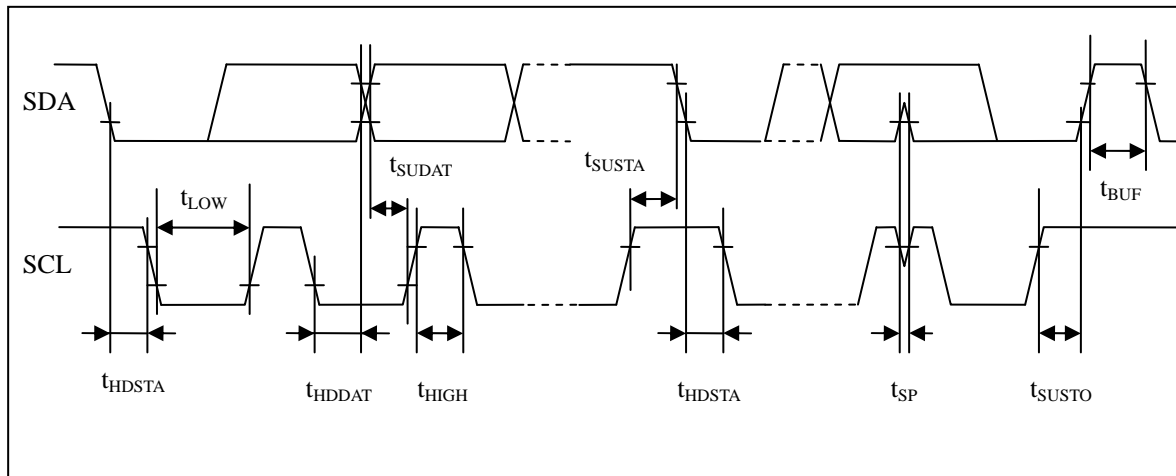

(5) Timer input timing

(T_A : -40°C to $+125^{\circ}\text{C}$, $V_{CC}=AV_{CC}=5.0\text{V} \pm 10\%/V_{CC}=AV_{CC}=3.3\text{V} \pm 0.3\text{V}, V_{SS}=AV_{SS}=0.0\text{V}$)

Parameter	Symbol	Pin name	Conditions	Value		Unit	Remarks
				Min	Max		
Input pulse width	t_{TIWH} , t_{TIWL}	TIN0 to TIN7 ICU0 to ICU9 FRCK0 to FRCK5 TIOA0, TIOA1, TIOB0, TIOB1, AIN0, AIN1, BIN0, BIN1, ZIN0, ZIN1	—	$4t_{CPP}$	—	ns	

• Timer input timing

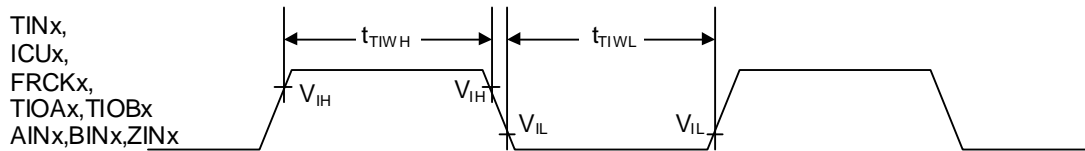

(6) Trigger input timing

(T_A : -40°C to $+125^{\circ}\text{C}$, $V_{CC}=AV_{CC}=5.0\text{V} \pm 10\%/V_{CC}=AV_{CC}=3.3\text{V} \pm 0.3\text{V}, V_{SS}=AV_{SS}=0.0\text{V}$)

Parameter	Symbol	Pin name	Conditions	Value		Unit	Remarks
				Min	Max		
Input pulse width	t_{TRGH} , t_{TRGL}	INT0 to INT15, ADTG, RX0, RX1, RX2	—	$5t_{CPP}$	—	ns	
				1	—	μs	At stop mode

• Trigger input timing

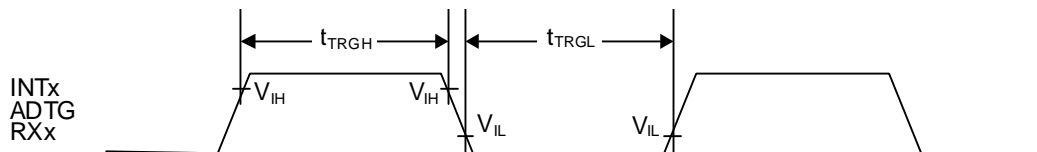

MB91520 Series

(7) NMI input timing

(T_A : -40°C to $+125^{\circ}\text{C}$, $V_{CC}=AV_{CC}=5.0\text{V} \pm 10\%$ / $V_{CC}=AV_{CC}=3.3\text{V} \pm 0.3\text{V}$, $V_{SS}=AV_{SS}=0.0\text{V}$)

Parameter	Symbol	Pin name	Conditions	Value		Unit	Remarks
				Min	Max		
Input pulse width	t_{NMIL}	NMIX	–	$4t_{\text{CPP}}$	–	ns	

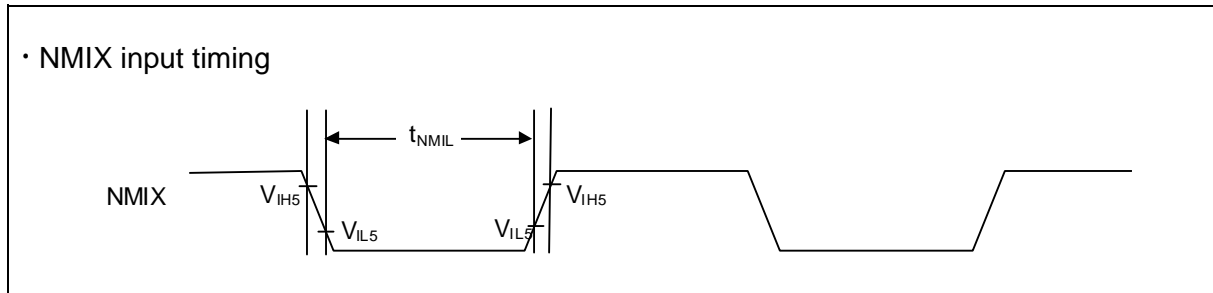

(8) Low voltage detection (External low-voltage detection)

(T_A: -40°C to +125°C, V_{SS}=AV_{SS}=0.0V)

Parameter	Symbol	Pin name	Condi- tions	Value			Unit	Remarks
				Min	Typ	Max		
Power supply voltage range	V _{DP5}	VCC	-	2.7	-	5.5	V	
Detection voltage	V _{DL}		*1	-8%	2.8	+8%	V	When power-supply voltage falls and detection level is set initially
Hysteresis width	V _{HYS}		-	-	0.1	-	V	When power-supply voltage rises
Low voltage detection time	T _d	-	-	-	-	30	μs	
Power supply voltage regulation	-	VCC	-	-2	-	2	V/ms	*2

*1: If the fluctuation of the power supply is faster than the low voltage detection time, there is a possibility to generate or release after the power supply voltage has exceeded the detection voltage range.

*2: Please suppress the change of the power supply within the range of the power-supply voltage regulation to do a low voltage detection by detecting voltage (V_{DL}).

(9) Low voltage detection (Internal low-voltage detection)

(T_A: -40°C to +125°C, V_{SS}=AV_{SS}=0.0V)

Parameter	Symbol	Pin name	Condi- tions	Value			Unit	Remarks
				Min	Typ	Max		
Power supply voltage range	V _{RDP5}	-	-	0.6	-	1.4	V	
Detection voltage	V _{RDL}		*	0.8	0.9	1.0	V	When power-supply voltage falls
Hysteresis width	V _{RHYS}		-	-	0.1	-	V	When power-supply voltage rises
Low voltage detection time	-	-	-	-	-	30	μs	

*: If the fluctuation of the power supply is faster than the low voltage detection time, there is a possibility to generate or release after the power supply voltage has exceeded the detection voltage range.

MB91520 Series

(10) External bus I/F (synchronous mode) timing

(T_A : -40°C to $+105^{\circ}\text{C}$, $V_{CC}=AV_{CC}=5.0\text{V}\pm 10\%/V_{CC}=AV_{CC}=3.3\text{V}\pm 0.3\text{V}$, $V_{SS}=AV_{SS}=0.0\text{V}$)

(external load capacitance 50pF)

Parameter	Symbol	Pin name	Value		Unit	Remarks
			Min	Max		
Cycle time	t_{CYC}	SYSCLK	25	-	ns	$V_{CC}=5.0\text{V}\pm 10\%$ *1
			31.25			$V_{CC}=3.3\text{V}\pm 0.3\text{V}$
ASX delay time	t_{CHASL} , t_{CHASH}	SYSCLK ASX	0.5	18	ns	
CS0X to CS3X delay time	t_{CHCSL} , t_{CHCSH}	SYSCLK CS0X to CS3X	0.5	18	ns	
A00 to A21 delay time	t_{CHAV} , t_{CHAX}	SYSCLK A00 to A21	0.5	18	ns	
RDX delay time	t_{CHRL} , t_{CHRH}	SYSCLK RDX	0.5	18	ns	
RDX minimum pulse	t_{RLRH}	RDX	$t_{CYC}\times$ 2 - 20	-	ns	RWT=1, set RWT to 1 or more. *2
Data setup \rightarrow RDX \uparrow time	t_{DSRH}	RDX D16 to D31	$18+t_{CYC}$	-	ns	Same as above
RDX \uparrow \rightarrow data hold	t_{RHDH}		0	-	ns	
WRnX delay time	t_{CHWL} , t_{CHWH}	SYSCLK WR0X, WR1X	0.5	18	ns	
WRnX minimum pulse	t_{WLWH}	WR0X, WR1X	$t_{CYC} - 10$	-	ns	WWT=0 *2
SYSCLK \uparrow \rightarrow data output time	t_{CHDV}	SYSCLK D16 to D31	0.5	18	ns	
SYSCLK \uparrow \rightarrow data hold time	t_{CHDX}		-	18	ns	Set WRCS to 1 or more.

Parameter	Symbol	Pin name	Value		Unit	Remarks
			Min	Max		
SYSCLK↑→ address output time	t_{CHMAX}		0.5	18	ns	
SYSCLK↑→ address hold time	t_{CHMAX}	SYSCLK D16 to D31	-	18	ns	In multiplex mode, set as follows: <ul style="list-style-type: none"> • Set CSWR and CSRD to 2 or more. • ASCY must satisfy the following conditions because of setting $ADCY > ASCY$ and protocol violation prevention. $ADCY + 1 \leq ACS + CSRD$ $ADCY + 1 \leq ACS + CSWR$ $ASCY + 1 \leq ACS + CSRD$ $ASCY + 1 \leq ACS + CSWR$ See Hardware Manual for details.

*1: Please use it with external load capacity 12pF or less for $VCC=3.3V\pm 0.3V$ (40MHz operation).

*2: If the bus is expanded by automatic wait insertion or RDY input, add time ($t_{CYC} \times$ the number of expanded cycles) to the rated value.

External bus I/F (synchronous mode, read operation, and multiplex mode) timing

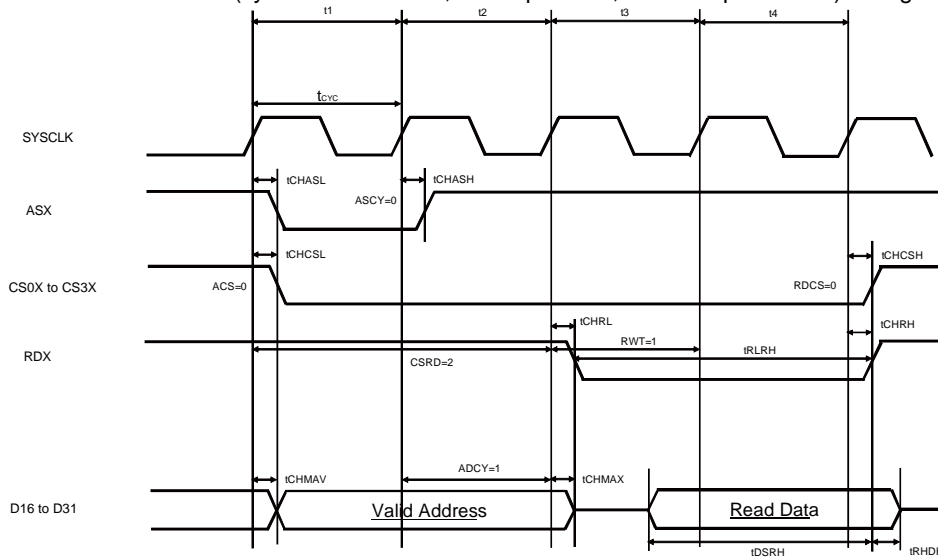

External bus I/F (synchronous mode, read operation, and split mode) timing

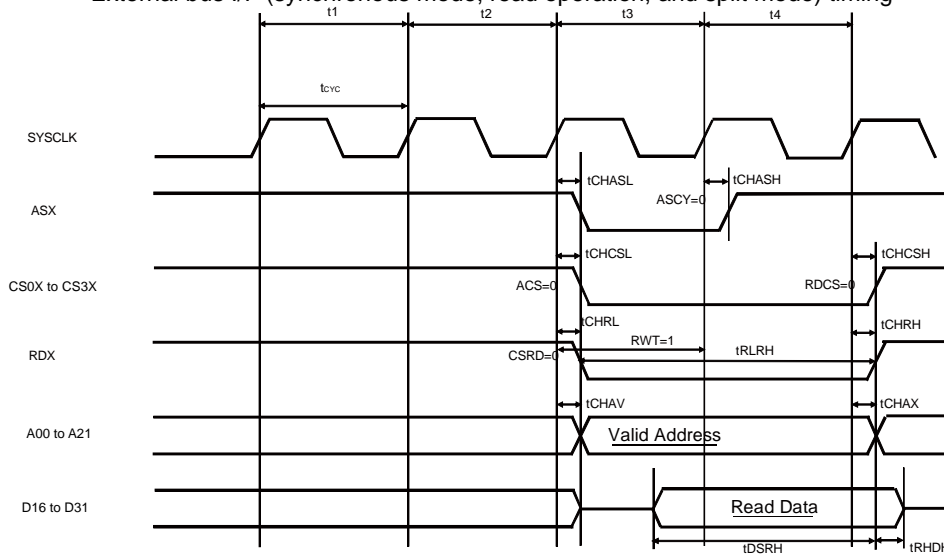

External bus I/F (synchronous mode, write operation, and multiplex mode) timing

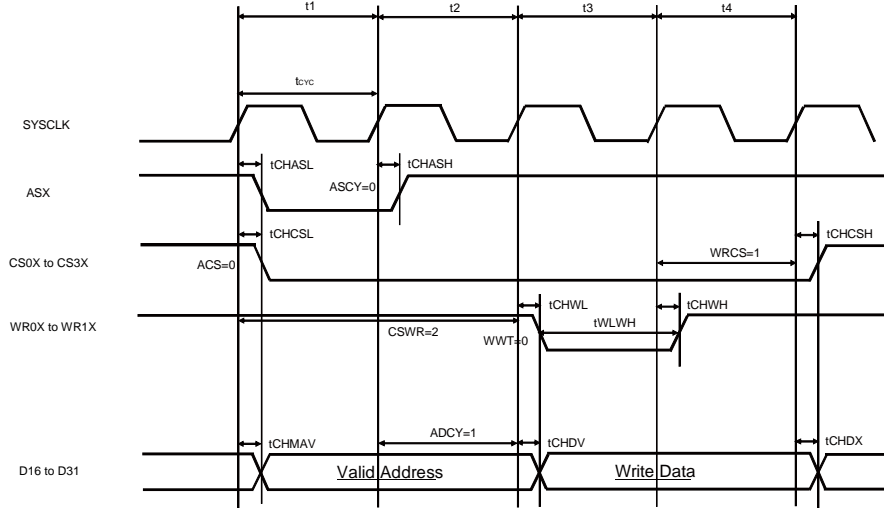

External bus I/F (synchronous mode, write operation, and split mode) timing

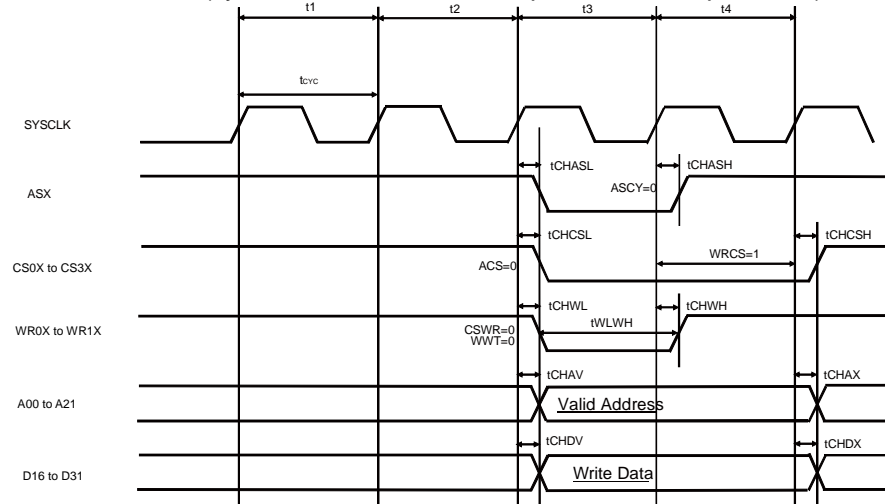

MB91520 Series

(11) External bus I/F (asynchronous mode) timing

(T_A : -40°C to +105°C, $V_{CC}=AV_{CC}=5.0V\pm 10\%/V_{CC}=AV_{CC}=3.3V\pm 0.3V, V_{SS}=AV_{SS}=0.0V$)
(external load capacitance 50pF)

Parameter	Symbol	Pin name	Value		Unit	Remarks
			Min	Max		
Cycle time	t_{CYC}	SYSCLK	25	-	ns	$V_{CC}=5.0V\pm 10\%$ *1
			31.25			$V_{CC}=3.3V\pm 0.3V$
Address setup → RDX↑time	t_{ASRH}	RDX A00 to A21	$2\times t_{CYC} - 12$	$2\times t_{CYC} + 12$	ns	RWT=1, set RWT to 1 or more. *2
RDX↑→ Address hold	t_{RHAH}		$t_{CYC} - 12$	$t_{CYC} + 12$	ns	Set RDCS to 1 or more.
Data setup→ RDX↑time	t_{DSRH}	RDX D16 to D31	$18 + t_{CYC}$	-	ns	RWT=1, set RWT to 1 or more.
RDX↑→ Data hold	t_{RHDH}		0	-	ns	
Address setup→ WRnX↑time	t_{ASWH}	WR0X to WR1X A00 to A21	$t_{CYC} - 12$	$t_{CYC} + 12$	ns	WWT=0 *2
WRnX↑→ Address hold	t_{WHAH}		$t_{CYC} - 12$	$t_{CYC} + 12$	ns	Set WRCS to 1 or more.
Data setup→ WRnX↑time	t_{DSWH}	WR0X to WR1X D16 to D31	$t_{CYC} - 16$	$t_{CYC} + 16$	ns	WWT=0 *2
WRnX↑→ Data hold	t_{WHDH}		$t_{CYC} - 16$	$t_{CYC} + 16$	ns	Set WRCS to 1 or more.
Address setup → ASX↑time	t_{MASASH}	ASX D16 to D31	$t_{CYC}-16$	$t_{CYC}+ 16$	ns	ASCY=0
ASX↑→Address hold	t_{MASAH}		$t_{CYC}-16$	$t_{CYC} + 16$	ns	In multiplex mode, set as follows: <ul style="list-style-type: none"> • Set CSWR and CSRD to 2 or more. • ASCY must satisfy the following conditions because of setting $ADCY > ASCY$ and protocol violation prevention. $ADCY + 1 \leq ACS + CSRD$ $ADCY + 1 \leq ACS + CSWR$ $ASCY + 1 \leq ACS + CSRD$ $ASCY + 1 \leq ACS + CSWR$ See Hardware Manual for details.

*1: Please use it with external load capacity 12pF or less for $V_{CC}=3.3V\pm 0.3V$ (40MHz operation).

*2: If the bus is expanded by automatic wait insertion or RDY input, add time ($t_{CYC} \times$ the number of expanded cycles) to the rated value.

External bus I/F (asynchronous mode, read operation, and multiplex mode) Timing

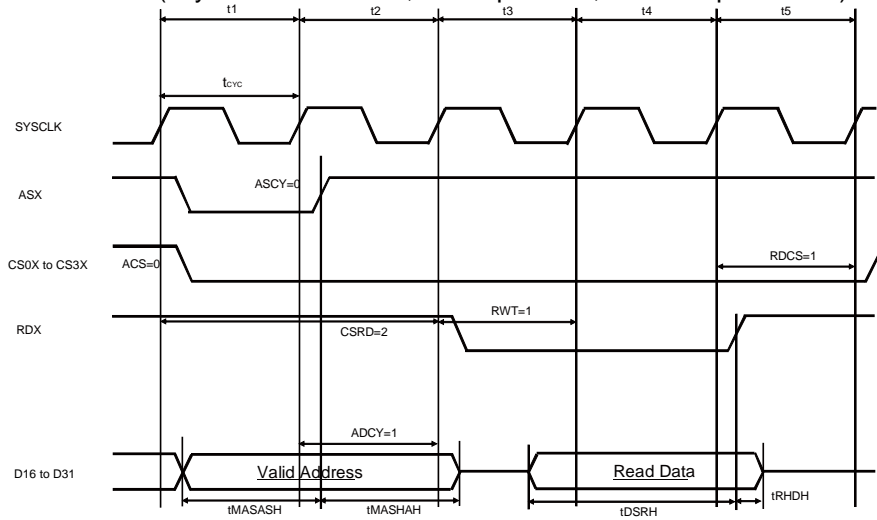

External bus I/F (asynchronous mode, read operation, and split mode) Timing

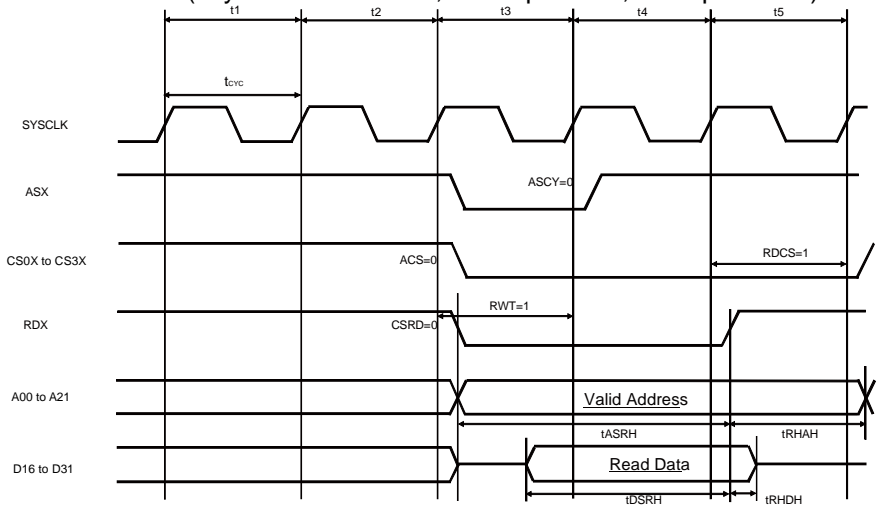

External bus I/F (asynchronous mode, write operation, and multiplex mode) Timing

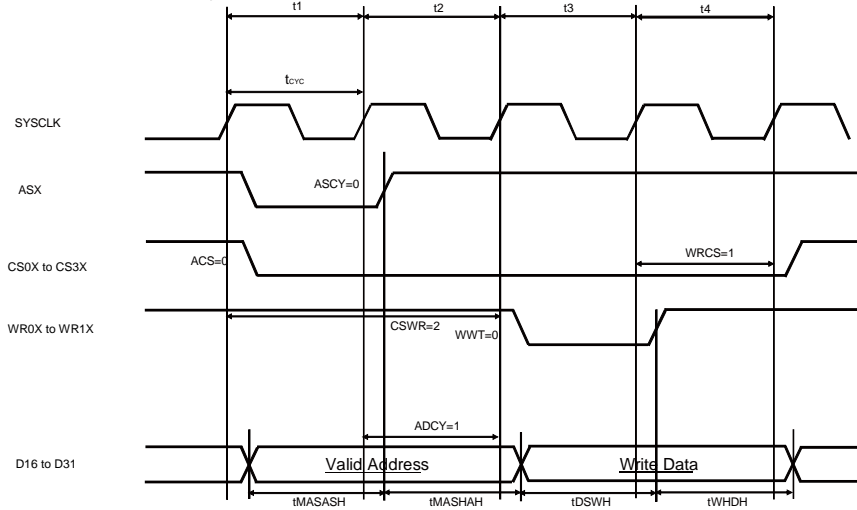

External bus I/F (Asynchronous mode, write operation, and split mode) Timing

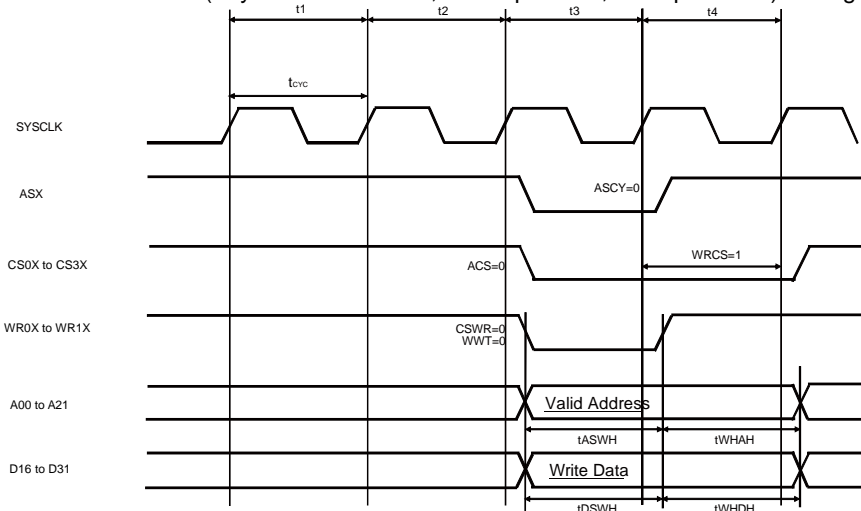

(12) External bus I/F (ready) Timing

(T_A : -40°C to $+105^{\circ}\text{C}$, $V_{CC}=\text{AV}_{CC}=5.0\text{V} \pm 10\%$ / $V_{CC}=\text{AV}_{CC}=3.3\text{V} \pm 0.3\text{V}$, $V_{SS}=\text{AV}_{SS}=0.0\text{V}$)
 (external load capacitance 50pF)

Parameter	Symbol	Pin name	Value		Unit	Remarks
			Min	Max		
Cycle time	t_{CYC}	SYCLK	50	-	ns	If using RDY, set SYCLK to 20 MHz or less.
RDY setup time → SYCLK↑	t_{RDYS}	SYCLK, RDY	28	-	ns	
SYCLK↑→ RDY hold time	t_{RDYH}	SYCLK, RDY	0	-	ns	

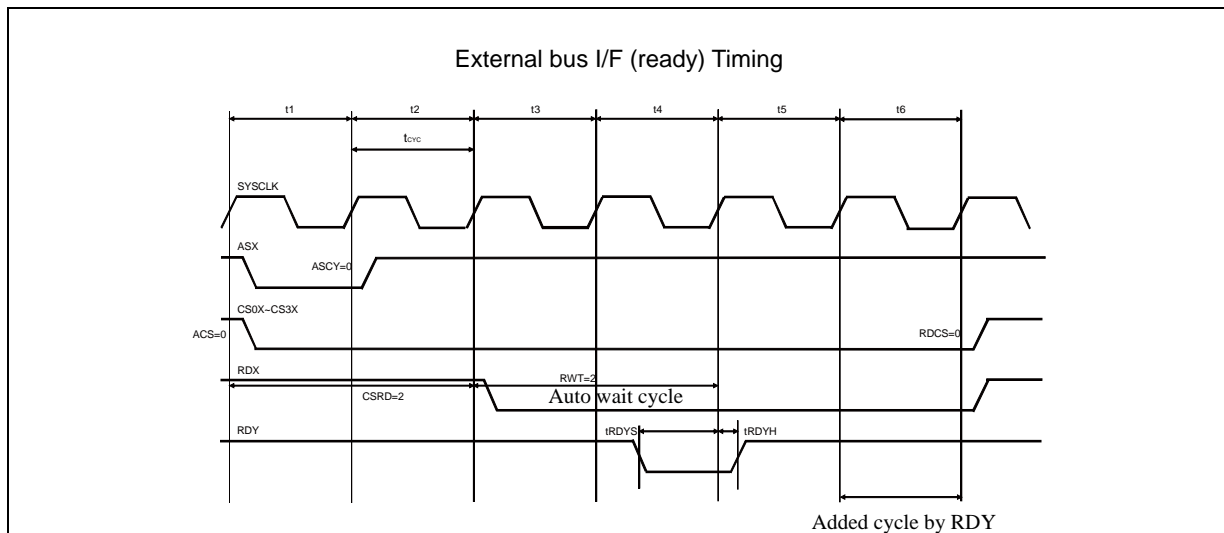

MB91520 Series

5. A/D Converter

(1) 12-bit A/D Converter Electrical Characteristics

(T_A : -40°C to $+125^{\circ}\text{C}$, $V_{CC}=\text{AV}_{CC}=5.0\text{V} \pm 10\%/V_{CC}=\text{AV}_{CC}=3.3\text{V} \pm 0.3\text{V}, V_{SS}=\text{AV}_{SS}=0.0\text{V}$)

Parameter	Symbol	Pin name	Value			Unit	Remarks
			Min	Typ	Max		
Resolution	-	-	-	-	12	bit	
Linearity error	-	-	-	-	± 4.0	LSB	
Differential linearity error	-	-	-	-	± 1.9	LSB	
Zero transition voltage	V_{OT}	AN0 to AN47	AVRL+ 0.5LSB -20mV	-	AVRL+ 0.5LSB +20mV	V	1LSB= ($V_{FST}-V_{OT}$)/ 4094
Full-scale transition voltage	V_{FST}	AN0 to AN47	AVRH- 1.5LSB -20mV	-	AVRH- 1.5LSB +20mV	V	
Sampling time	t_{SMP}	-	0.7	-	-	μs	*1
Compare time	t_{CMP}	-	0.7	-	-	μs	*1
A/D conversion time	t_{CNV}	-	1.4	-	-	μs	*1
Analog port input current	I_{AIN}	AN0 to AN47	-1.0	-	+1.0	μA	$V_{AVSS} \leq V_{AIN} \leq V_{AVCC}$
Analog input voltage	V_{AIN}	AN0 to AN47	AVRL	-	AVRH	V	
Reference voltage	AVRH	AVRH	3.0	-	5.5	V	
	AVRL	AVSS/ AVRL	-	0.0	-	V	
Power supply current	I_A	AVCC	-	0.47	0.63	mA	Per unit $T_A: +105^{\circ}\text{C}$
			-	0.47	0.7	mA	Per unit $T_A: +125^{\circ}\text{C}$
	I_{AH}	-	-	2.5	μA	*2	
	I_R	AVRH	-	1	1.96	mA	Per unit
	I_{RH}		-	-	1.6	μA	*2
Variation between channels	-	AN0 to AN47	-	-	4	LSB	

*1: Time for each channel.

*2: Power supply current ($V_{CC} = \text{AV}_{CC} = 5.0\text{V}$) is specified if A/D converter is not operating and CPU is stopped.

(Note) Please use the clock of 0.5MHz-20MHz for the output clock of A/D converter to guarantee accuracy.

(2) Definition of A/D Converter Terms

- Resolution** : Analog variation that is recognized by an A/D converter.
- Linearity error** : Deviation of the actual conversion characteristics from a straight line that connects the zero transition point ("0000 0000 0000" ← → "0000 0000 0001") to the full-scale transition point ("1111 1111 1110" ← → "1111 1111 1111").
- Differential linearity error** : Deviation of the input voltage from the ideal value that is required to change the output code by LSB.

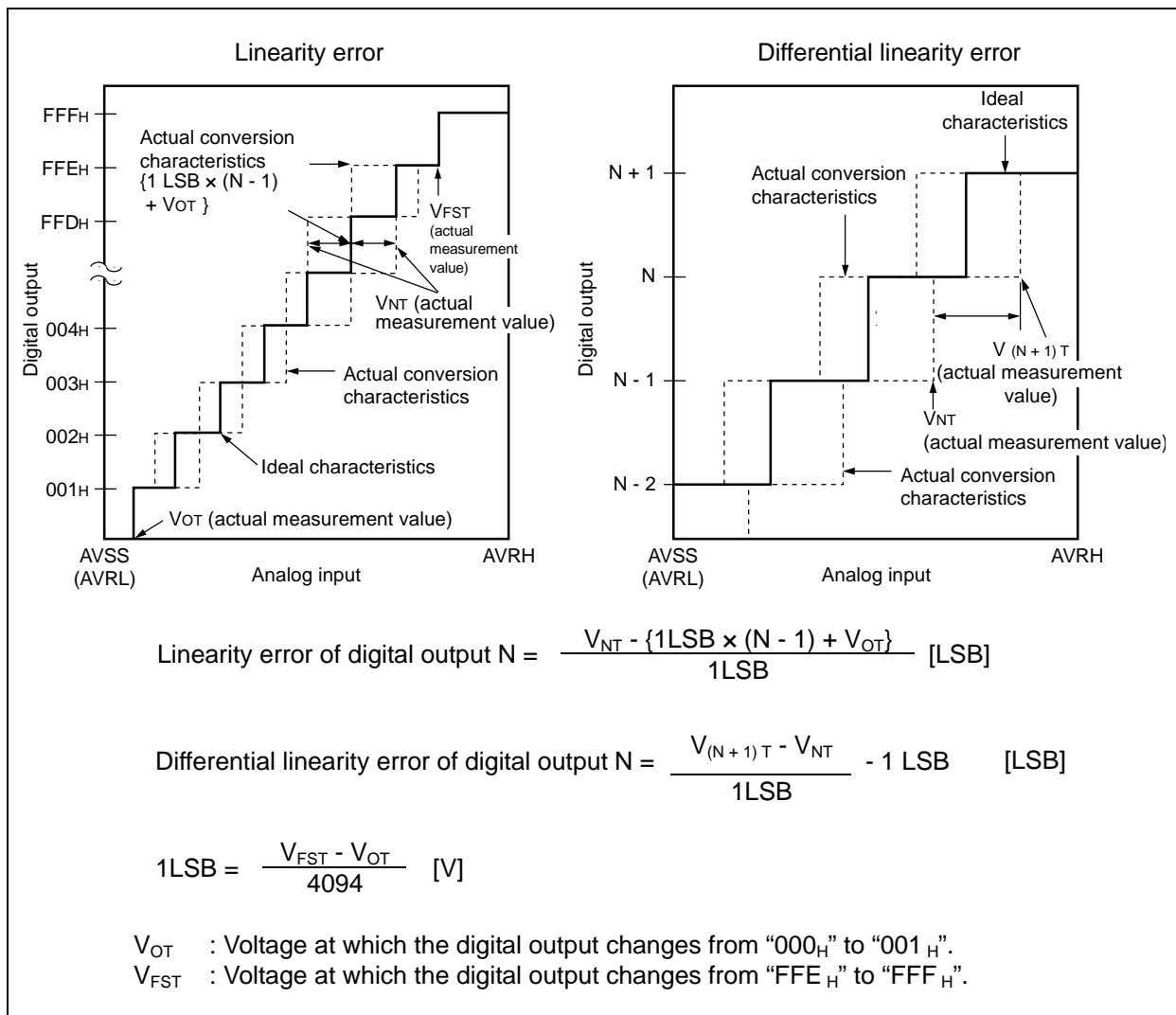

MB91520 Series

(3) Notes on Using A/D Converter

<About the output impedance of the analog input of external circuit>

- When the external impedance is too high, the sampling period for analog voltages may not be sufficient. In this case, it is recommended to connect the capacitor (approx. 0.1 μF) to the analog input pin.

• Analog input circuit model

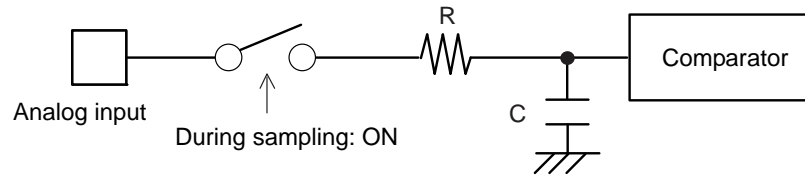

	R	C	
12bit A/D	1.9k Ω (Max)	8.30pF (Max)	(4.5V \leq AV _{CC} \leq 5.5V)
	4.3k Ω (Max)	8.30pF (Max)	(3.0V \leq AV _{CC} \leq 3.6V)

Note: Listed values must be considered as reference values.

6. Flash memory

(1) Electrical Characteristics

Parameter	Value			Unit	Remarks
	Min	Typ	Max		
Sector erase time	–	200	800	ms	8 Kbytes sector* ¹ , excluding internal preprogramming time
	–	300	1100	ms	8 Kbytes sector* ¹ , including internal preprogramming time
	–	400	2000	ms	64 Kbytes sector* ¹ , excluding internal preprogramming time
	–	700	3700	ms	64 Kbytes sector* ¹ , including internal preprogramming time
8-bit writing time	–	9	288	μs	Exclusive of overhead time at system level* ¹
16-bit writing time	–	12	384	μs	Exclusive of overhead time at system level* ¹
ECC writing time	–	9	288	μs	Exclusive of overhead time at system level* ¹
Erase cycle* ² / Data retain time	1,000 cycles/ 20 years, 10,000 cycles/ 10 years, 100,000 cycles/ 5 years	–	–	–	Temperature at writing/erasing T _j <+105°C, Average T _A =+85°C* ³

*1: The guaranteed value for erasure up to 100,000 cycles.

*2: Number of erase cycles for each sector.

*3: This value comes from the technology qualification (using Arrhenius equation to translate high temperature measurements into normalized value at + 85°C).

(2) Notes

While the Flash memory is written or erased, shutdown of the external power (V_{cc}) is prohibited. In the application system where V_{cc} might be shut down while writing or erasing, be sure to turn the power off by using an external voltage detection function.

To put it concretely, after the external power supply voltage falls below the detection voltage (V_{DL}*), hold V_{cc} at 2.7V or more within the duration calculated by the following expression:

$$T_d^* [\mu s] + (\text{period of PCLK} [\mu s] \times 257) + 50 [\mu s]$$

*: See "4.AC Characteristics (8) Low-voltage detection (External low-voltage detection) "

MB91520 Series

7. D/A converter

(T_A : -40°C to +125°C, $V_{CC}=AV_{CC}=5.0V \pm 10\%$ / $V_{CC}=AV_{CC}=3.3V \pm 0.3V$, $V_{SS}=AV_{SS}=0.0V$)

Parameter	Symbol	Pin name	Condition	Value			Unit	Remarks
				Min	Typ	Max		
Resolution	-	-	-	-	-	8	bit	
Differential linearity error	-	-	-	-	-	± 3.0	LSB	
Conversion time	-	-	-	0.47	0.58	0.69	μs	$C_L=20$
			-	2.37	2.90	3.43	μs	$C_L=100$
Output impedance	R_o	DA0, DA1	-	3.1	3.8	4.5	k Ω	
Power supply current	IA	AV_{CC}	-	-	475	580	μA	Each channel
	IAH	AV_{CC}	-	-	-	7.5	μA	When powerdown Each channel

■ EXAMPLE CHARACTERISTICS

This characteristic is an actual value of the arbitrary sample. It is not the guaranteed value.

• MB91F526

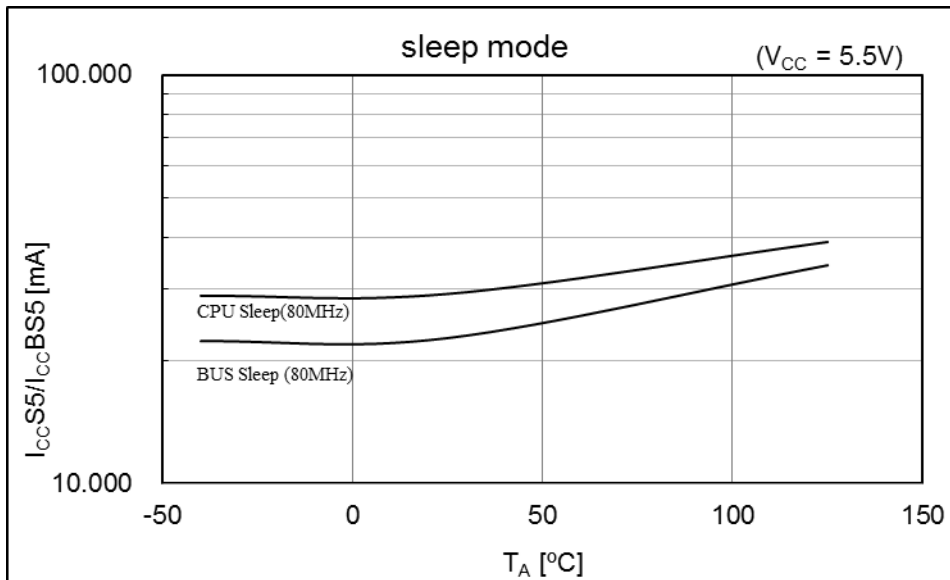
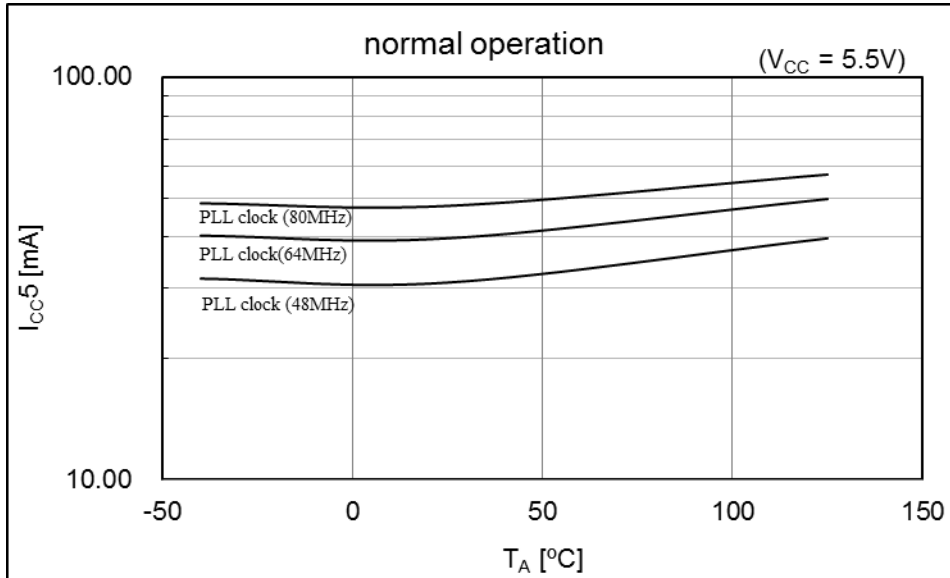

MB91520 Series

• MB91F526

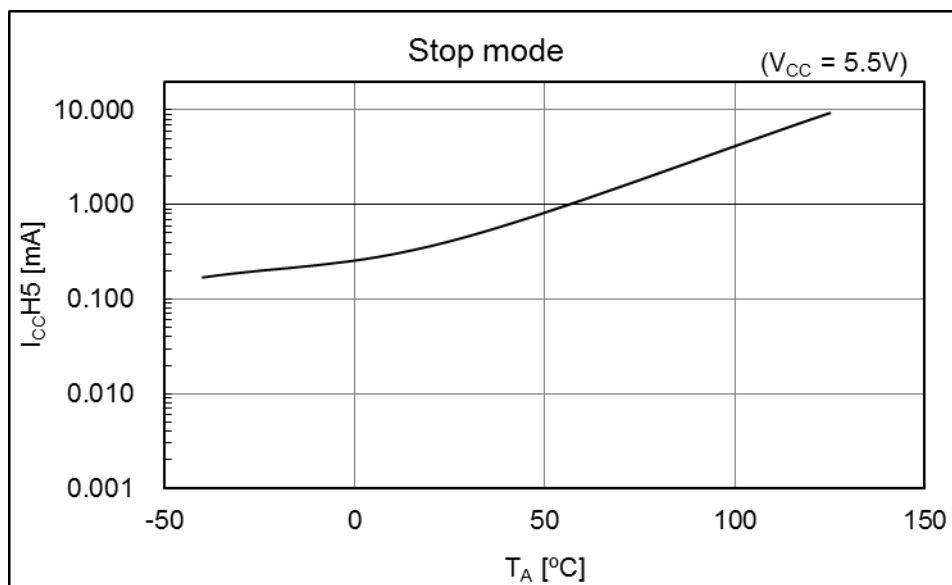
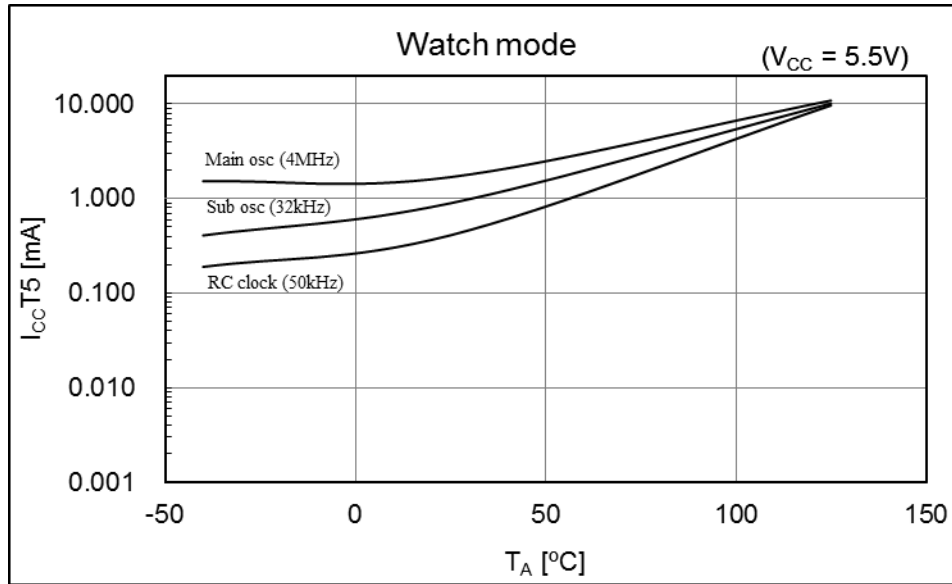

• MB91F526

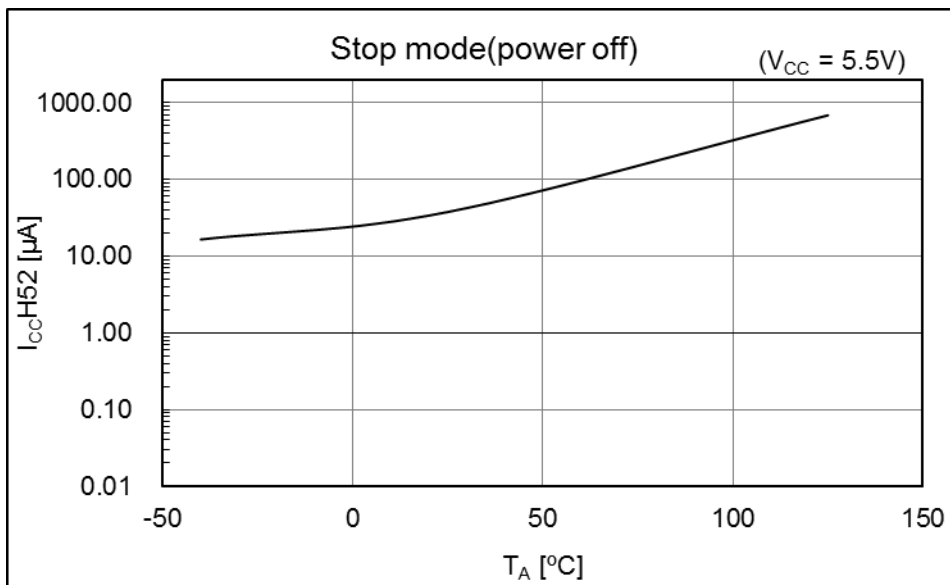
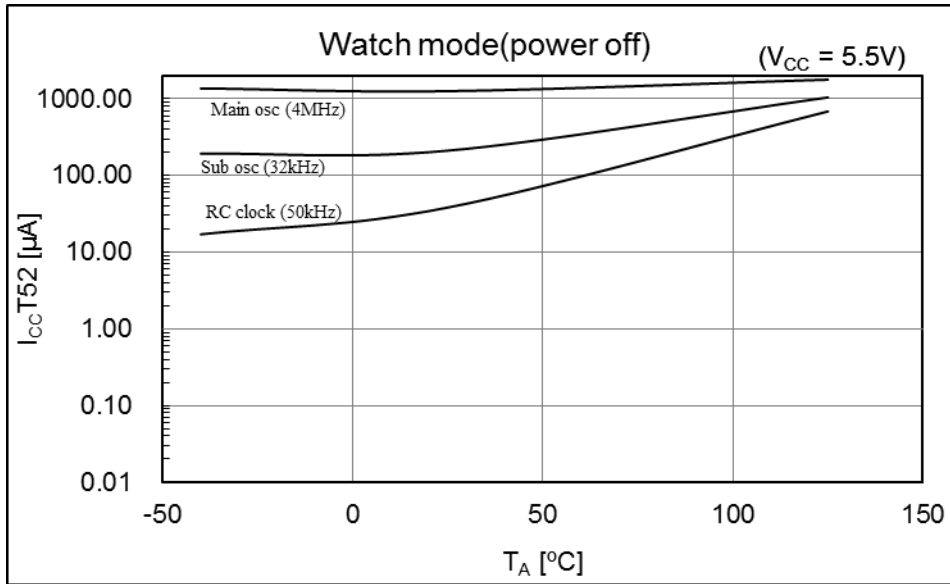

MB91520 Series

■ ORDERING INFORMATION

Part number	Sub clock	CSV Initial value	LVD Initial value	Package*
MB91F526LWBPMC	Yes	ON	ON	LQFP • 176 pin, Plastic (FPT-176P-M07)
MB91F526LYBPMC			OFF	
MB91F526LJBPMC		OFF	ON	
MB91F526LLBPMC			OFF	
MB91F525LWBPMC		ON	ON	
MB91F525LYBPMC			OFF	
MB91F525LJBPMC		OFF	ON	
MB91F525LLBPMC			OFF	
MB91F524LWBPMC		ON	ON	
MB91F524LYBPMC			OFF	
MB91F524LJBPMC		OFF	ON	
MB91F524LLBPMC			OFF	
MB91F523LWBPMC		ON	ON	
MB91F523LYBPMC			OFF	
MB91F523LJBPMC		OFF	ON	
MB91F523LLBPMC			OFF	
MB91F522LWBPMC		ON	ON	
MB91F522LYBPMC			OFF	
MB91F522LJBPMC		OFF	ON	
MB91F522LLBPMC			OFF	
MB91F526LSBPMC	None	ON	ON	
MB91F526LUBPMC			OFF	
MB91F526LHBPMC		OFF	ON	
MB91F526LKBPMC			OFF	
MB91F525LSBPMC		ON	ON	
MB91F525LUBPMC			OFF	
MB91F525LHBPMC		OFF	ON	
MB91F525LKBPMC			OFF	
MB91F524LSBPMC		ON	ON	
MB91F524LUBPMC			OFF	
MB91F524LHBPMC		OFF	ON	
MB91F524LKBPMC			OFF	
MB91F523LSBPMC		ON	ON	
MB91F523LUBPMC			OFF	
MB91F523LHBPMC		OFF	ON	
MB91F523LKBPMC			OFF	
MB91F522LSBPMC		ON	ON	
MB91F522LUBPMC			OFF	
MB91F522LHBPMC		OFF	ON	
MB91F522LKBPMC			OFF	

MB91520 Series

Part number	Sub clock	CSV Initial value	LVD Initial value	Package*
MB91F526KWBPMC	Yes	ON	ON	LQFP • 144 pin, (Lead pitch 0.5mm) Plastic (FPT-144P-M08)
MB91F526KYBPMC			OFF	
MB91F526KJBPMC		OFF	ON	
MB91F526KLBPMC			OFF	
MB91F525KWBPMC		ON	ON	
MB91F525KYBPMC			OFF	
MB91F525KJBPMC		OFF	ON	
MB91F525KLBPMC			OFF	
MB91F524KWBPMC		ON	ON	
MB91F524KYBPMC			OFF	
MB91F524KJBPMC		OFF	ON	
MB91F524KLBPMC			OFF	
MB91F523KWBPMC		ON	ON	
MB91F523KYBPMC			OFF	
MB91F523KJBPMC		OFF	ON	
MB91F523KLBPMC			OFF	
MB91F522KWBPMC		ON	ON	
MB91F522KYBPMC			OFF	
MB91F522KJBPMC		OFF	ON	
MB91F522KLBPMC			OFF	
MB91F526KSBPMC	None	ON	ON	
MB91F526KUBPMC			OFF	
MB91F526KHBPMC		OFF	ON	
MB91F526KKBPMC			OFF	
MB91F525KSBPMC		ON	ON	
MB91F525KUBPMC			OFF	
MB91F525KHBPMC		OFF	ON	
MB91F525KKBPMC			OFF	
MB91F524KSBPMC		ON	ON	
MB91F524KUBPMC			OFF	
MB91F524KHBPMC		OFF	ON	
MB91F524KKBPMC			OFF	
MB91F523KSBPMC		ON	ON	
MB91F523KUBPMC			OFF	
MB91F523KHBPMC		OFF	ON	
MB91F523KKBPMC			OFF	
MB91F522KSBPMC		ON	ON	
MB91F522KUBPMC			OFF	
MB91F522KHBPMC		OFF	ON	
MB91F522KKBPMC			OFF	

MB91520 Series

Part number	Sub clock	CSV Initial value	LVD Initial value	Package*
MB91F526KWBPMC1	Yes	ON	ON	LQFP • 144 pin, (Lead pitch 0.4mm) Plastic (FPT-144P-M12)
MB91F526KYBPMC1			OFF	
MB91F526KJBPMC1		OFF	ON	
MB91F526KLBPMC1			OFF	
MB91F525KWBPMC1		ON	ON	
MB91F525KYBPMC1			OFF	
MB91F525KJBPMC1		OFF	ON	
MB91F525KLBPMC1			OFF	
MB91F524KWBPMC1		ON	ON	
MB91F524KYBPMC1			OFF	
MB91F524KJBPMC1		OFF	ON	
MB91F524KLBPMC1			OFF	
MB91F523KWBPMC1		ON	ON	
MB91F523KYBPMC1			OFF	
MB91F523KJBPMC1		OFF	ON	
MB91F523KLBPMC1			OFF	
MB91F522KWBPMC1		ON	ON	
MB91F522KYBPMC1			OFF	
MB91F522KJBPMC1		OFF	ON	
MB91F522KLBPMC1			OFF	
MB91F526KSBPMC1	None	ON	ON	
MB91F526KUBPMC1			OFF	
MB91F526KHBPMC1		OFF	ON	
MB91F526KKBPMC1			OFF	
MB91F525KSBPMC1		ON	ON	
MB91F525KUBPMC1			OFF	
MB91F525KHBPMC1		OFF	ON	
MB91F525KKBPMC1			OFF	
MB91F524KSBPMC1		ON	ON	
MB91F524KUBPMC1			OFF	
MB91F524KHBPMC1		OFF	ON	
MB91F524KKBPMC1			OFF	
MB91F523KSBPMC1		ON	ON	
MB91F523KUBPMC1			OFF	
MB91F523KHBPMC1		OFF	ON	
MB91F523KKBPMC1			OFF	
MB91F522KSBPMC1		ON	ON	
MB91F522KUBPMC1			OFF	
MB91F522KHBPMC1		OFF	ON	
MB91F522KKBPMC1			OFF	

MB91520 Series

Part number	Sub clock	CSV Initial value	LVD Initial value	Package*
MB91F526JWBPMC	Yes	ON	ON	LQFP • 120 pin, Plastic (FPT-120P-M21)
MB91F526JYBPMC			OFF	
MB91F526JJBPMC		OFF	ON	
MB91F526JLBPMC			OFF	
MB91F525JWBPMC		ON	ON	
MB91F525JYBPMC			OFF	
MB91F525JJBPMC		OFF	ON	
MB91F525JLBPMC			OFF	
MB91F524JWBPMC		ON	ON	
MB91F524JYBPMC			OFF	
MB91F524JJBPMC		OFF	ON	
MB91F524JLBPMC			OFF	
MB91F523JWBPMC		ON	ON	
MB91F523JYBPMC			OFF	
MB91F523JJBPMC		OFF	ON	
MB91F523JLBPMC			OFF	
MB91F522JWBPMC		ON	ON	
MB91F522JYBPMC			OFF	
MB91F522JJBPMC		OFF	ON	
MB91F522JLBPMC			OFF	
MB91F526JSBPMC	None	ON	ON	
MB91F526JUBPMC			OFF	
MB91F526JHBPMC		OFF	ON	
MB91F526JKBPMC			OFF	
MB91F525JSBPMC		ON	ON	
MB91F525JUBPMC			OFF	
MB91F525JHBPMC		OFF	ON	
MB91F525JKBPMC			OFF	
MB91F524JSBPMC		ON	ON	
MB91F524JUBPMC			OFF	
MB91F524JHBPMC		OFF	ON	
MB91F524JKBPMC			OFF	
MB91F523JSBPMC		ON	ON	
MB91F523JUBPMC			OFF	
MB91F523JHBPMC		OFF	ON	
MB91F523JKBPMC			OFF	
MB91F522JSBPMC		ON	ON	
MB91F522JUBPMC			OFF	
MB91F522JHBPMC		OFF	ON	
MB91F522JKBPMC			OFF	

MB91520 Series

Part number	Sub clock	CSV Initial value	LVD Initial value	Package*
MB91F526FWBPMC	Yes	ON	ON	LQFP • 100 pin, Plastic (FPT-100P-M20)
MB91F526FYBPMC			OFF	
MB91F526FJBPMC		OFF	ON	
MB91F526FLBPMC			OFF	
MB91F525FWBPMC		ON	ON	
MB91F525FYBPMC			OFF	
MB91F525FJBPMC		OFF	ON	
MB91F525FLBPMC			OFF	
MB91F524FWBPMC		ON	ON	
MB91F524FYBPMC			OFF	
MB91F524FJBPMC		OFF	ON	
MB91F524FLBPMC			OFF	
MB91F523FWBPMC		ON	ON	
MB91F523FYBPMC			OFF	
MB91F523FJBPMC		OFF	ON	
MB91F523FLBPMC			OFF	
MB91F522FWBPMC		ON	ON	
MB91F522FYBPMC			OFF	
MB91F522FJBPMC		OFF	ON	
MB91F522FLBPMC			OFF	
MB91F526FSBPMC	None	ON	ON	
MB91F526FUBPMC			OFF	
MB91F526FHBPMC		OFF	ON	
MB91F526FKBPMC			OFF	
MB91F525FSBPMC		ON	ON	
MB91F525FUBPMC			OFF	
MB91F525FHBPMC		OFF	ON	
MB91F525FKBPMC			OFF	
MB91F524FSBPMC		ON	ON	
MB91F524FUBPMC			OFF	
MB91F524FHBPMC		OFF	ON	
MB91F524FKBPMC			OFF	
MB91F523FSBPMC		ON	ON	
MB91F523FUBPMC			OFF	
MB91F523FHBPMC		OFF	ON	
MB91F523FKBPMC			OFF	
MB91F522FSBPMC		ON	ON	
MB91F522FUBPMC			OFF	
MB91F522FHBPMC		OFF	ON	
MB91F522FKBPMC			OFF	

MB91520 Series

Part number	Sub clock	CSV Initial value	LVD Initial value	Package*
MB91F526DWBPMC	Yes	ON	ON	LQFP · 80 pin, Plastic (FPT-80P-M21)
MB91F526DYBPMC			OFF	
MB91F526DJBPMC		OFF	ON	
MB91F526DLBPMC			OFF	
MB91F525DWBPMC		ON	ON	
MB91F525DYBPMC			OFF	
MB91F525DJBPMC		OFF	ON	
MB91F525DLBPMC			OFF	
MB91F524DWBPMC		ON	ON	
MB91F524DYBPMC			OFF	
MB91F524DJBPMC		OFF	ON	
MB91F524DLBPMC			OFF	
MB91F523DWBPMC		ON	ON	
MB91F523DYBPMC			OFF	
MB91F523DJBPMC		OFF	ON	
MB91F523DLBPMC			OFF	
MB91F522DWBPMC		ON	ON	
MB91F522DYBPMC			OFF	
MB91F522DJBPMC		OFF	ON	
MB91F522DLBPMC			OFF	
MB91F526DSBPMC	None	ON	ON	
MB91F526DUBPMC			OFF	
MB91F526DHBPMC		OFF	ON	
MB91F526DKBPMC			OFF	
MB91F525DSBPMC		ON	ON	
MB91F525DUBPMC			OFF	
MB91F525DHBPMC		OFF	ON	
MB91F525DKBPMC			OFF	
MB91F524DSBPMC		ON	ON	
MB91F524DUBPMC			OFF	
MB91F524DHBPMC		OFF	ON	
MB91F524DKBPMC			OFF	
MB91F523DSBPMC		ON	ON	
MB91F523DUBPMC			OFF	
MB91F523DHBPMC		OFF	ON	
MB91F523DKBPMC			OFF	
MB91F522DSBPMC		ON	ON	
MB91F522DUBPMC			OFF	
MB91F522DHBPMC		OFF	ON	
MB91F522DKBPMC			OFF	

MB91520 Series

Part number	Sub clock	CSV Initial value	LVD Initial value	Package*
MB91F526WBPMC1	Yes	ON	ON	LQFP · 64 pin, Plastic (FPT-64P-M24)
MB91F526BYBPMC1			OFF	
MB91F526BJBPMC1		OFF	ON	
MB91F526BLBPMC1			OFF	
MB91F525WBPMC1		ON	ON	
MB91F525BYBPMC1			OFF	
MB91F525BJBPMC1		OFF	ON	
MB91F525BLBPMC1			OFF	
MB91F524WBPMC1		ON	ON	
MB91F524BYBPMC1			OFF	
MB91F524BJBPMC1		OFF	ON	
MB91F524BLBPMC1			OFF	
MB91F523WBPMC1		ON	ON	
MB91F523BYBPMC1			OFF	
MB91F523BJBPMC1		OFF	ON	
MB91F523BLBPMC1			OFF	
MB91F522WBPMC1		ON	ON	
MB91F522BYBPMC1			OFF	
MB91F522BJBPMC1		OFF	ON	
MB91F522BLBPMC1			OFF	
MB91F526BSBPMC1	None	ON	ON	
MB91F526BUBPMC1			OFF	
MB91F526BHBPMC1		OFF	ON	
MB91F526BKBPMC1			OFF	
MB91F525BSBPMC1		ON	ON	
MB91F525BUBPMC1			OFF	
MB91F525BHBPMC1		OFF	ON	
MB91F525BKBPMC1			OFF	
MB91F524BSBPMC1		ON	ON	
MB91F524BUBPMC1			OFF	
MB91F524BHBPMC1		OFF	ON	
MB91F524BKBPMC1			OFF	
MB91F523BSBPMC1		ON	ON	
MB91F523BUBPMC1			OFF	
MB91F523BHBPMC1		OFF	ON	
MB91F523BKBPMC1			OFF	
MB91F522BSBPMC1		ON	ON	
MB91F522BUBPMC1			OFF	
MB91F522BHBPMC1		OFF	ON	
MB91F522BKBPMC1			OFF	

*: For details of the package, see "■ PACKAGE DIMENSIONS".

■ PACKAGE DIMENSIONS

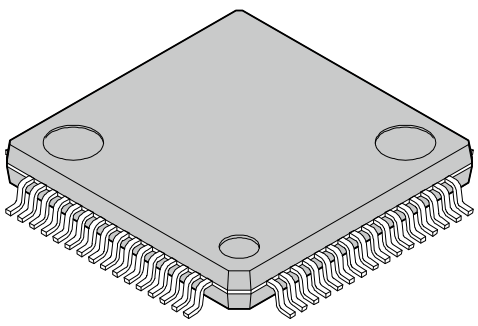
<p>64-pin plastic LQFP</p>  <p>(FPT-64P-M24)</p>	Lead pitch	0.50 mm
	Package width x package length	10.0 x 10.0 mm
	Lead shape	Gullwing
	Sealing method	Plastic mold
	Mounting height	1.70 mm MAX
	Weight	0.32 g
	Code (Reference)	P-LFQFP64-10x10-0.50

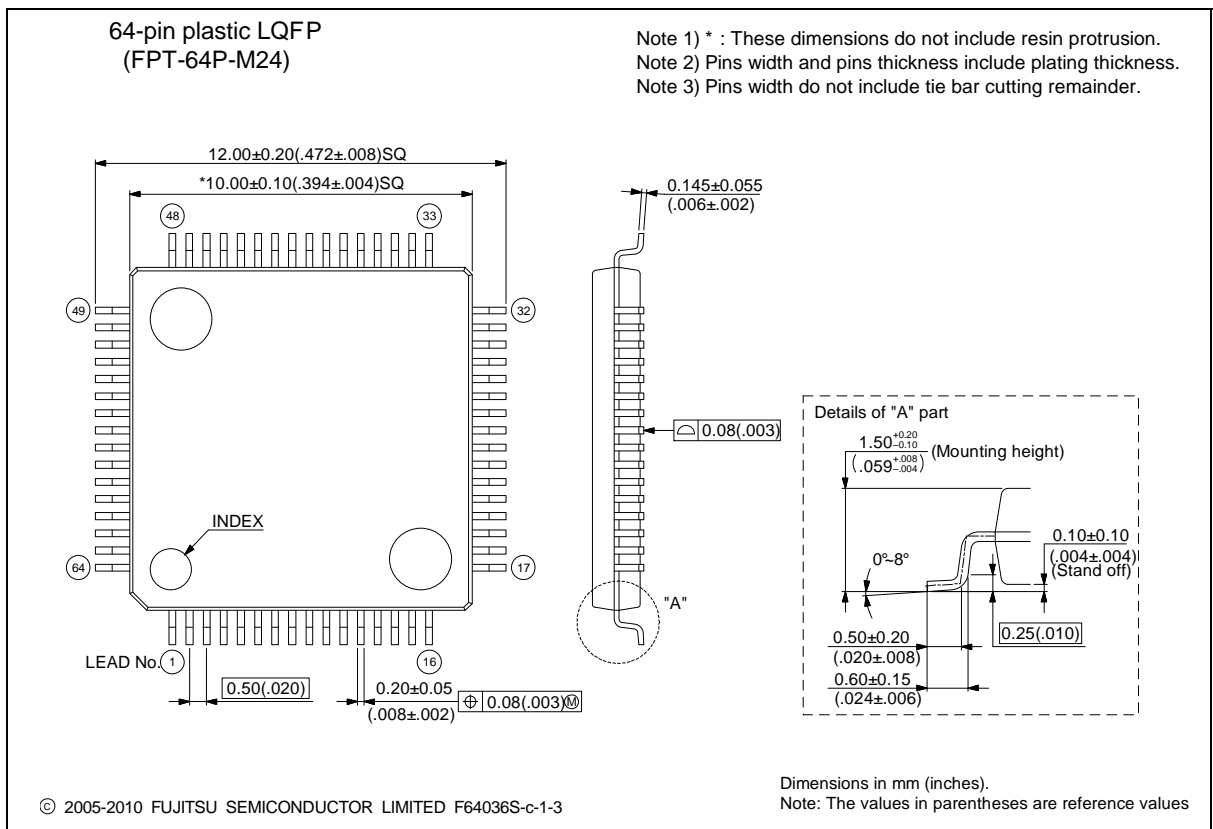

Please confirm the latest Package dimension by following URL.
<http://edevice.fujitsu.com/package/en-search/>

MB91520 Series

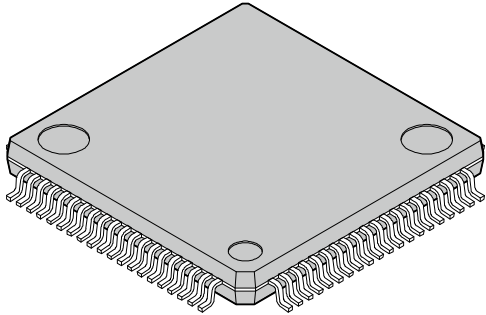
<p style="text-align: center;">80-pin plastic LQFP</p>  <p style="text-align: center;">(FPT-80P-M21)</p>	Lead pitch	0.50 mm
	Package width × package length	12 mm × 12 mm
	Lead shape	Gullwing
	Sealing method	Plastic mold
	Mounting height	1.70 mm Max
	Weight	0.47 g
	Code (Reference)	P-LFQFP80-12×12-0.50

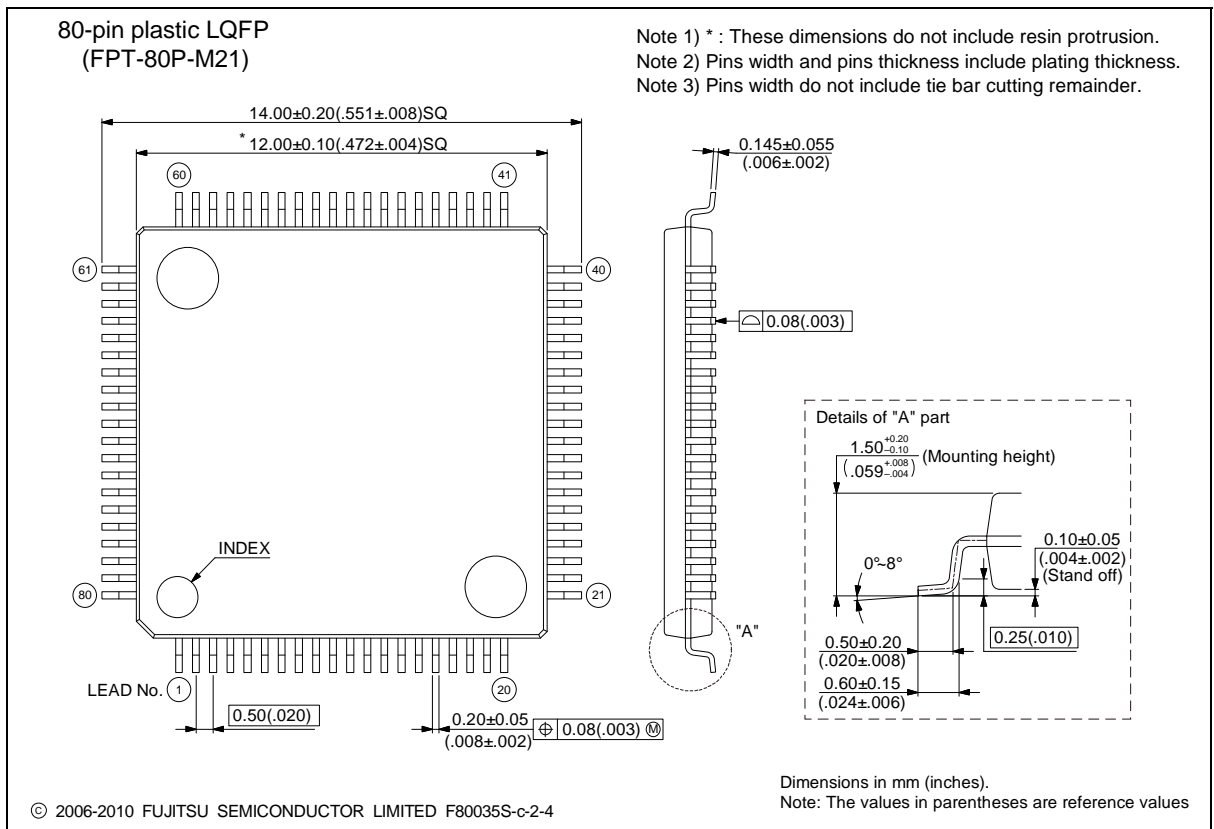

Please confirm the latest Package dimension by following URL.
<http://edevice.fujitsu.com/package/en-search/>

MB91520 Series

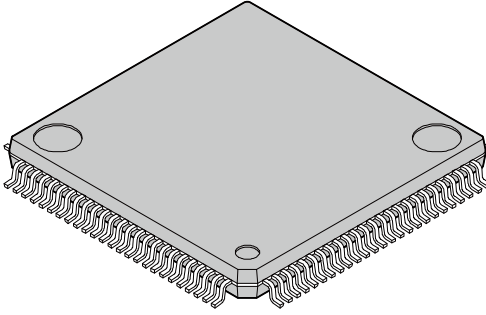
<p style="text-align: center;">100-pin plastic LQFP</p>  <p style="text-align: center;">(FPT-100P-M20)</p>	Lead pitch	0.50 mm
	Package width × package length	14.0 mm × 14.0 mm
	Lead shape	Gullwing
	Sealing method	Plastic mold
	Mounting height	1.70 mm Max
	Weight	0.65 g
	Code (Reference)	P-LFQFP100-14×14-0.50

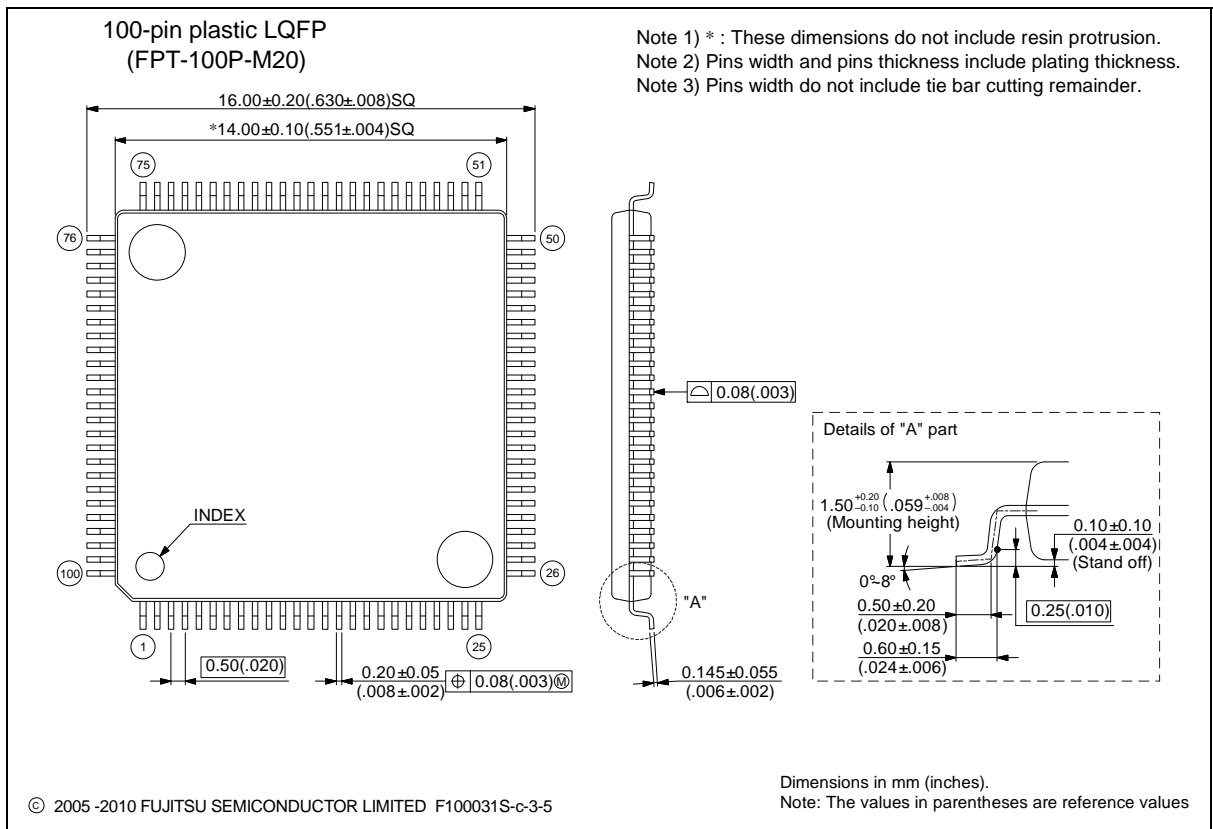

Please confirm the latest Package dimension by following URL.
<http://edevice.fujitsu.com/package/en-search/>

MB91520 Series

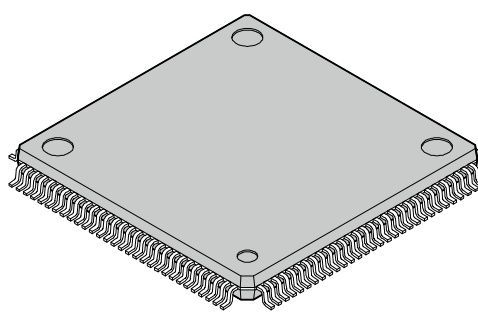
<p style="text-align: center;">120-pin plastic LQFP</p>  <p style="text-align: center;">(FPT-120P-M21)</p>	Lead pitch	0.50 mm
	Package width × package length	16.0 × 16.0 mm
	Lead shape	Gullwing
	Sealing method	Plastic mold
	Mounting height	1.70 mm MAX
	Weight	0.88 g
	Code (Reference)	P-LFQFP120-16×16-0.50

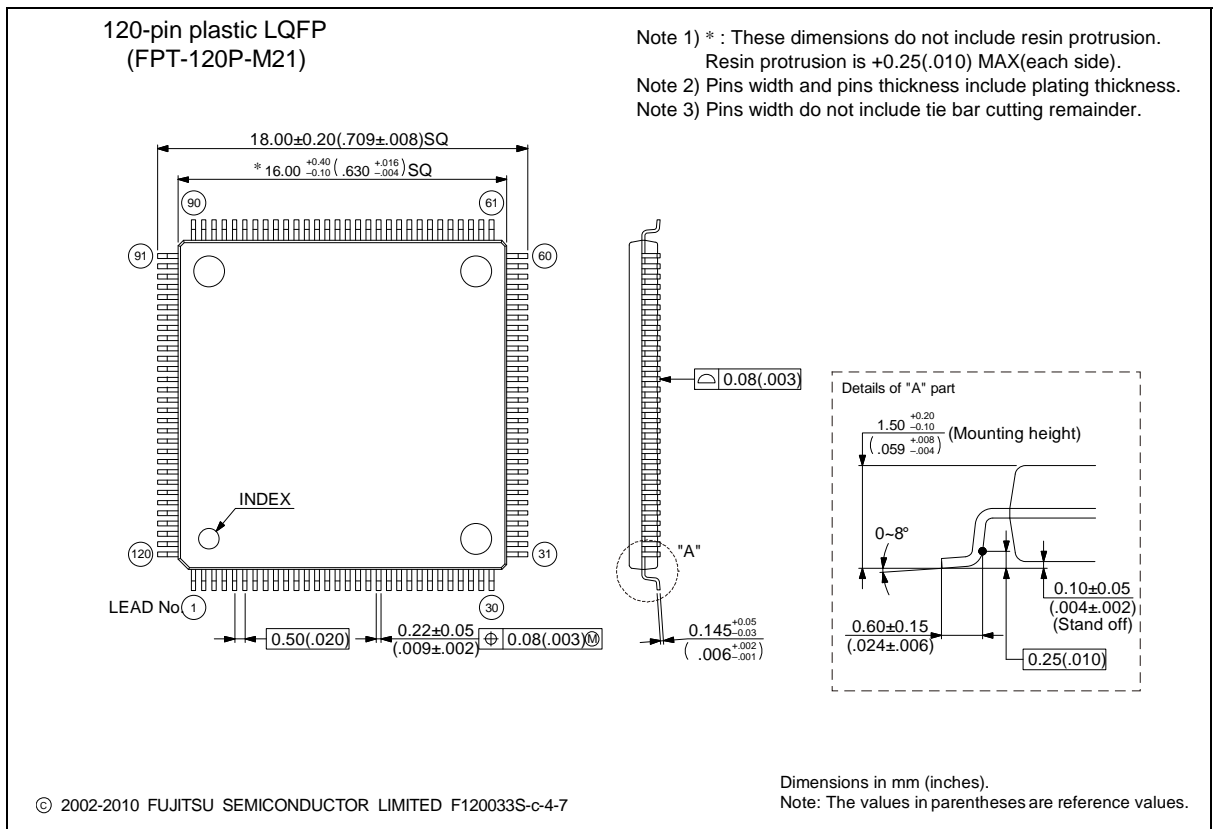

Please confirm the latest Package dimension by following URL.
<http://edevice.fujitsu.com/package/en-search/>

MB91520 Series

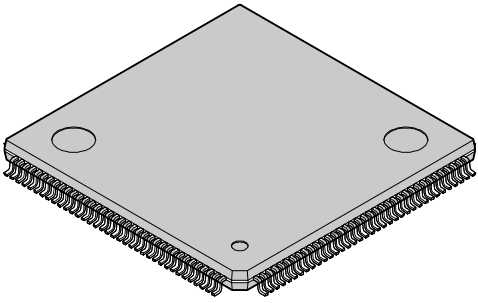
<p>144-pin plastic LQFP</p>  <p>(FPT-144P-M08)</p>	Lead pitch	0.50 mm
	Package width × package length	20.0 × 20.0 mm
	Lead shape	Gullwing
	Sealing method	Plastic mold
	Mounting height	1.70 mm MAX
	Weight	1.20 g
	Code (Reference)	P-LFQFP144-20×20-0.50

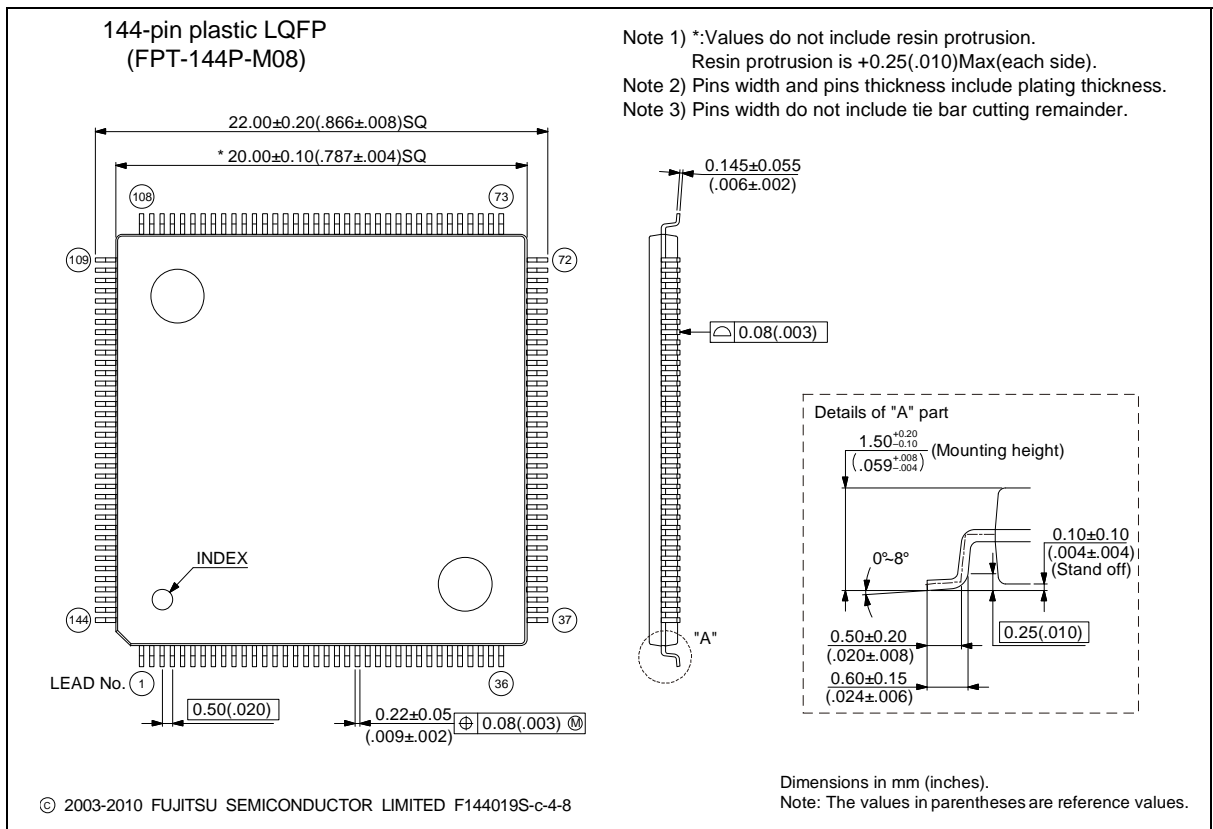

Please confirm the latest Package dimension by following URL.
<http://edevice.fujitsu.com/package/en-search/>

MB91520 Series

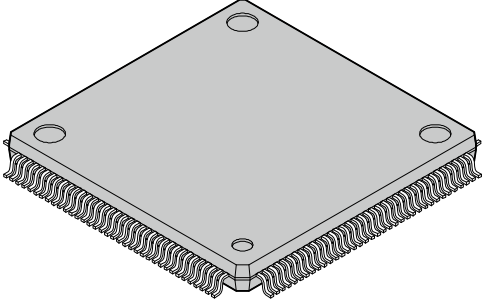
<p style="text-align: center;">144-pin plastic LQFP</p>  <p style="text-align: center;">(FPT-144P-M12)</p>	Lead pitch	0.40 mm
	Package width x package length	16.0 x 16.0 mm
	Lead shape	Gullwing
	Sealing method	Plastic mold
	Mounting height	1.70 mm MAX
	Weight	0.88 g
	Code (Reference)	P-LFQFP144-16x16-0.40

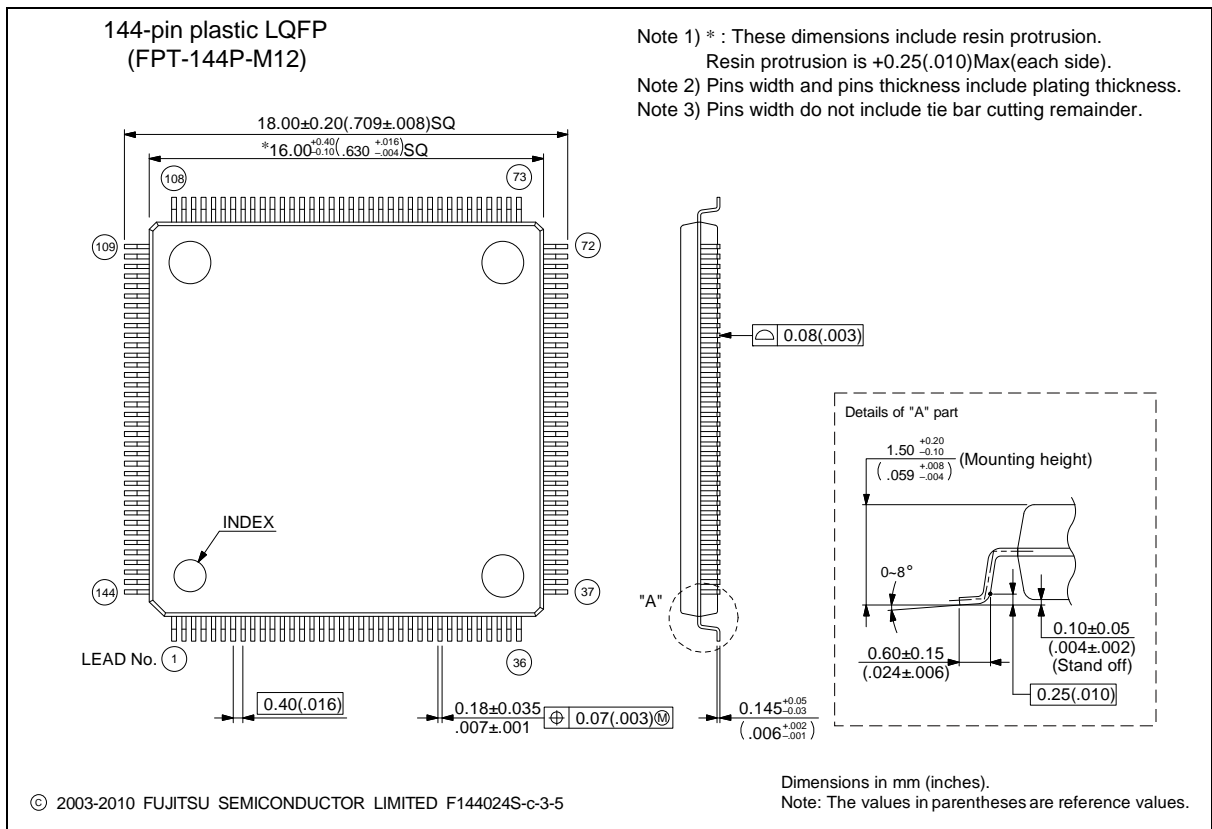

Please confirm the latest Package dimension by following URL.
<http://edevice.fujitsu.com/package/en-search/>

MB91520 Series

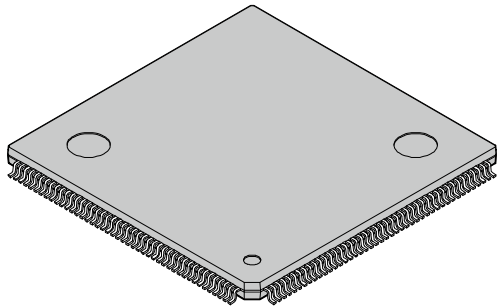
<p style="text-align: center;">176-pin plastic LQFP</p>  <p style="text-align: center;">(FPT-176P-M07)</p>	Lead pitch	0.50 mm
	Package width x package length	24.0 x 24.0 mm
	Lead shape	Gullwing
	Sealing method	Plastic mold
	Mounting height	1.70 mm MAX
	Code (Reference)	P-LQFP-0176-2424-0.50

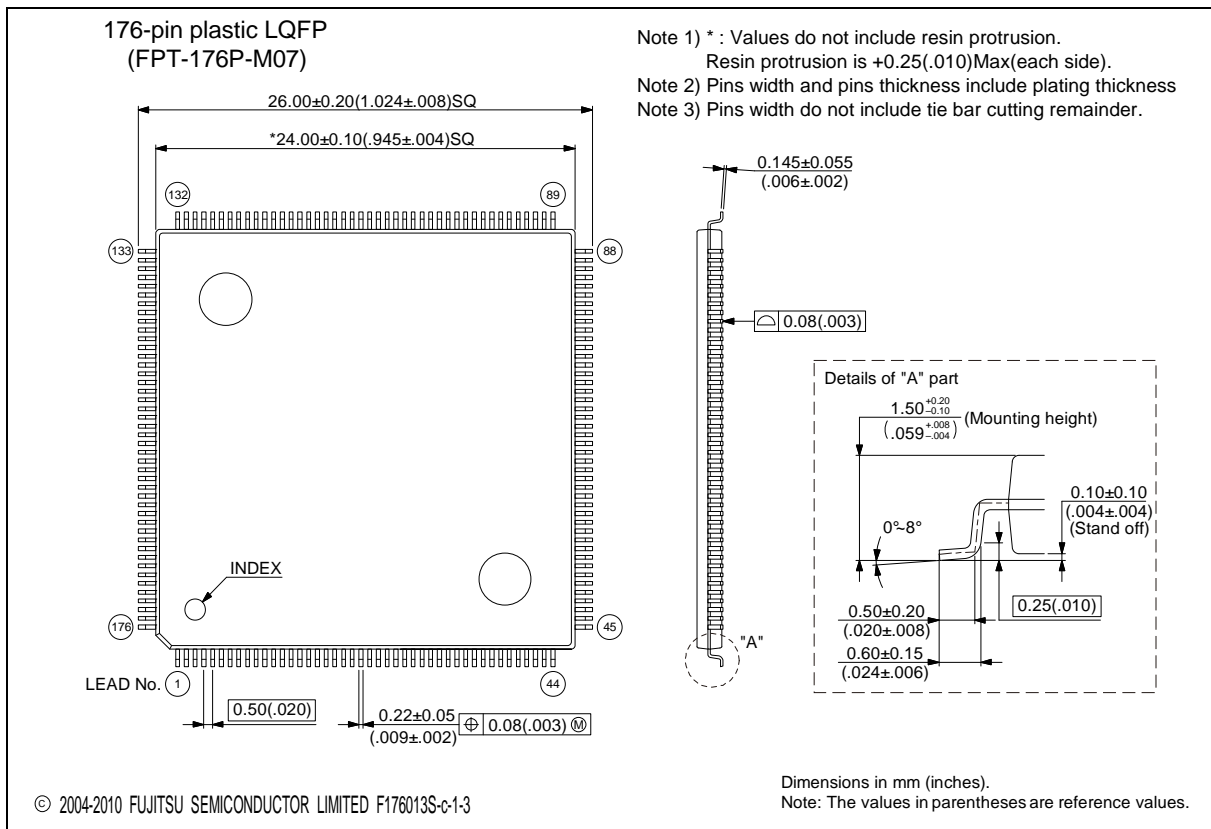

Please confirm the latest Package dimension by following URL.
<http://edevice.fujitsu.com/package/en-search/>

MEMO

MEMO

MB91520 Series

FUJITSU SEMICONDUCTOR LIMITED

Nomura Fudosan Shin-yokohama Bldg. 10-23, Shin-yokohama 2-Chome,
Kohoku-ku Yokohama Kanagawa 222-0033, Japan

Tel: +81-45-415-5858

<http://jp.fujitsu.com/fsl/en/>

For further information please contact:

North and South America

FUJITSU SEMICONDUCTOR AMERICA, INC.
1250 E. Arques Avenue, M/S 333
Sunnyvale, CA 94085-5401, U.S.A.
Tel: +1-408-737-5600 Fax: +1-408-737-5999
<http://us.fujitsu.com/micro/>

Asia Pacific

FUJITSU SEMICONDUCTOR ASIA PTE. LTD.
151 Lorong Chuan,
#05-08 New Tech Park 556741 Singapore
Tel : +65-6281-0770 Fax : +65-6281-0220
<http://sg.fujitsu.com/semiconductor/>

Europe

FUJITSU SEMICONDUCTOR EUROPE GmbH
Pittlerstrasse 47, 63225 Langen, Germany
Tel: +49-6103-690-0 Fax: +49-6103-690-122
<http://emea.fujitsu.com/semiconductor/>

FUJITSU SEMICONDUCTOR SHANGHAI CO., LTD.

30F, Kerry Parkside, 1155 Fang Dian Road,
Pudong District, Shanghai 201204, China
Tel : +86-21-6146-3688 Fax : +86-21-6146-3660
<http://cn.fujitsu.com/fss/>

Korea

FUJITSU SEMICONDUCTOR KOREA LTD.
902 Kosmo Tower Building, 1002 Daechi-Dong,
Gangnam-Gu, Seoul 135-280, Republic of Korea
Tel: +82-2-3484-7100 Fax: +82-2-3484-7111
<http://kr.fujitsu.com/fsk/>

FUJITSU SEMICONDUCTOR PACIFIC ASIA LTD.

2/F, Green 18 Building, Hong Kong Science Park,
Shatin, N.T., Hong Kong
Tel : +852-2736-3232 Fax : +852-2314-4207
<http://cn.fujitsu.com/fsp/>

All Rights Reserved.

FUJITSU SEMICONDUCTOR LIMITED, its subsidiaries and affiliates (collectively, "FUJITSU SEMICONDUCTOR") reserves the right to make changes to the information contained in this document without notice. Please contact your FUJITSU SEMICONDUCTOR sales representatives before order of FUJITSU SEMICONDUCTOR device. Information contained in this document, such as descriptions of function and application circuit examples is presented solely for reference to examples of operations and uses of FUJITSU SEMICONDUCTOR device. FUJITSU SEMICONDUCTOR disclaims any and all warranties of any kind, whether express or implied, related to such information, including, without limitation, quality, accuracy, performance, proper operation of the device or non-infringement. If you develop equipment or product incorporating the FUJITSU SEMICONDUCTOR device based on such information, you must assume any responsibility or liability arising out of or in connection with such information or any use thereof. FUJITSU SEMICONDUCTOR assumes no responsibility or liability for any damages whatsoever arising out of or in connection with such information or any use thereof. Nothing contained in this document shall be construed as granting or conferring any right under any patents, copyrights, or any other intellectual property rights of FUJITSU SEMICONDUCTOR or any third party by license or otherwise, express or implied. FUJITSU SEMICONDUCTOR assumes no responsibility or liability for any infringement of any intellectual property rights or other rights of third parties resulting from or in connection with the information contained herein or use thereof. The products described in this document are designed, developed and manufactured as contemplated for general use including without limitation, ordinary industrial use, general office use, personal use, and household use, but are not designed, developed and manufactured as contemplated (1) for use accompanying fatal risks or dangers that, unless extremely high levels of safety is secured, could lead directly to death, personal injury, severe physical damage or other loss (including, without limitation, use in nuclear facility, aircraft flight control system, air traffic control system, mass transport control system, medical life support system and military application), or (2) for use requiring extremely high level of reliability (including, without limitation, submersible repeater and artificial satellite). FUJITSU SEMICONDUCTOR shall not be liable for you and/or any third party for any claims or damages arising out of or in connection with above-mentioned uses of the products. Any semiconductor devices fail or malfunction with some probability. You are responsible for providing adequate designs and safeguards against injury, damage or loss from such failures or malfunctions, by incorporating safety design measures into your facility, equipments and products such as redundancy, fire protection, and prevention of overcurrent levels and other abnormal operating conditions. The products and technical information described in this document are subject to the Foreign Exchange and Foreign Trade Control Law of Japan, and may be subject to export or import laws or regulations in U.S. or other countries. You are responsible for ensuring compliance with such laws and regulations relating to export or re-export of the products and technical information described herein. All company names, brand names and trademarks herein are property of their respective owners.

Edited: Sales Promotion Department