

8-bit Microcontrollers

New 8FX MB95610H Series

MB95F613H/F613K/F614H/F614K/F616H/F616K

■ DESCRIPTION

The MB95610H Series is a series of general-purpose, single-chip microcontrollers. In addition to a compact instruction set, the microcontrollers of these series contain a variety of peripheral resources.

■ FEATURES

• F²MC-8FX CPU core

Instruction set optimized for controllers

- Multiplication and division instructions
- 16-bit arithmetic operations
- Bit test branch instructions
- Bit manipulation instructions, etc.

Note: F²MC is the abbreviation of FUJITSU Flexible Microcontroller.

• Clock

• Selectable main clock source

Main oscillation clock (up to 16.25 MHz, maximum machine clock frequency: 8.125 MHz)

External clock (up to 32.5 MHz, maximum machine clock frequency: 16.25 MHz)

Main CR clock (4 MHz ±2%)

Main PLL clock / Main CR PLL clock (Main oscillation clock = 4 MHz, Main CR clock = 4 MHz)

Both main oscillation clock and main CR clock can be multiplied by a PLL multiplier.

The frequency of the main PLL clock / main CR PLL clock becomes 8 MHz when the PLL multiplier is 2.

The frequency of the main PLL clock / main CR PLL clock becomes 10 MHz when the PLL multiplier is 2.5.

The frequency of the main PLL clock / main CR PLL clock becomes 12 MHz when the PLL multiplier is 3.

The frequency of the main PLL clock / main CR PLL clock becomes 16 MHz when the PLL multiplier is 4.

• Selectable subclock source

Sub-oscillation clock (32.768 kHz)

External clock (32.768 kHz)

Sub-CR clock (Typ: 100 kHz, Min: 50 kHz, Max: 150 kHz)

(Continued)

FUJITSU SEMICONDUCTOR provides information facilitating product development via the following website.
The website contains information useful for customers.

<http://edevic.fujitsu.com/micom/en-support/>

(Continued)

- Timer
 - 8/16-bit composite timer × 2 channels
 - 8/16-bit PPG × 2 channels
 - 16-bit reload timer × 1 channel
 - Event counter × 1 channel
 - Time-base timer × 1 channel
 - Watch counter × 1 channel
 - Watch prescaler × 1 channel
- UART/SIO × 2 channels
 - Full duplex double buffer
 - Capable of clock-asynchronized (UART) serial data transfer and clock-synchronized (SIO) serial data transfer
- I²C bus interface × 1 channel
 - Built-in wake-up function
- External interrupt × 8 channels
 - Interrupt by edge detection (rising edge, falling edge, and both edges can be selected)
 - Can be used to wake up the device from different low power consumption (standby) modes
- 8/10-bit A/D converter × 4 channels
 - 8-bit or 10-bit resolution can be selected.
- LCD controller (LCDC)
 - LCD output can be selected from 52 SEG × 4 COM or 48 SEG × 8 COM.
 - Internal divider resistor whose resistance value can be selected from 10 kΩ or 100 kΩ through software
 - Interrupt in sync with the LCD module frame frequency
 - Blinking function
 - Inverted display function
- Low power consumption (standby) modes

There are four standby modes as follows:

 - Stop mode
 - Sleep mode
 - Watch mode
 - Time-base timer mode

In standby mode, two further options can be selected: normal standby mode and deep standby mode.
- I/O port
 - MB95F613H/F614H/F616H (no. of I/O ports: 40)

General-purpose I/O ports (CMOS I/O)	: 39
General-purpose I/O ports (N-ch open drain)	: 1
 - MB95F613K/F614K/F616K (no. of I/O ports: 41)

General-purpose I/O ports (CMOS I/O)	: 39
General-purpose I/O ports (N-ch open drain)	: 2
- On-chip debug
 - 1-wire serial control
 - Serial writing supported (asynchronous mode)
- Hardware/software watchdog timer
 - Built-in hardware watchdog timer
 - Built-in software watchdog timer
- Power-on reset
 - A power-on reset is generated when the power is switched on.
- Low-voltage detection (LVD) reset circuit (only available on MB95F613K/F614K/F616K)
 - Built-in low-voltage detector (The combination of detection voltage and release voltage can be selected from four options.)
- Clock supervisor counter
 - Built-in clock supervisor counter
- Dual operation Flash memory
 - The program/erase operation and the read operation can be executed in different banks (upper bank/lower bank) simultaneously.
- Flash memory security function
 - Protects the content of the Flash memory.

■ PRODUCT LINE-UP

Part number	MB95F613H	MB95F614H	MB95F616H	MB95F613K	MB95F614K	MB95F616K
Parameter						
Type	Flash memory product					
Clock supervisor counter	It supervises the main clock oscillation and the subclock oscillation.					
Flash memory capacity	12 Kbyte	20 Kbyte	36 Kbyte	12 Kbyte	20 Kbyte	36 Kbyte
RAM capacity	512 bytes	1024 bytes	1024 bytes	512 bytes	1024bytes	1024 bytes
Power-on reset	Yes					
Low-voltage detection reset	No			Yes		
Reset input	With dedicated reset input			Selected through software		
CPU functions	<ul style="list-style-type: none"> • Number of basic instructions : 136 • Instruction bit length : 8 bits • Instruction length : 1 to 3 bytes • Data bit length : 1, 8 and 16 bits • Minimum instruction execution time : 61.5 ns (machine clock frequency = 16.25 MHz) • Interrupt processing time : 0.6 μs (machine clock frequency = 16.25 MHz) 					
General-purpose I/O	<ul style="list-style-type: none"> • I/O port : 40 • CMOS I/O : 39 • N-ch open drain : 1 			<ul style="list-style-type: none"> • I/O port : 41 • CMOS I/O : 39 • N-ch open drain : 2 		
Time-base timer	Interval time: 0.256 ms to 8.3 s (external clock frequency = 4 MHz)					
Hardware/software watchdog timer	<ul style="list-style-type: none"> • Reset generation cycle Main oscillation clock at 10 MHz: 105 ms (Min) • The sub-CR clock can be used as the source clock of the software watchdog timer. 					
Wild register	It can be used to replace 3 bytes of data.					
8/10-bit A/D converter	4 channels 8-bit or 10-bit resolution can be selected.					
8/16-bit composite timer	2 channels <ul style="list-style-type: none"> • The timer can be configured as an "8-bit timer × 2 channels" or a "16-bit timer × 1 channel". • It has the following functions: interval timer function, PWC function, PWM function and input capture function. • Count clock: it can be selected from internal clocks (seven types) and external clocks. • It can output square wave. 					
External interrupt	8 channels <ul style="list-style-type: none"> • Interrupt by edge detection (The rising edge, falling edge, and both edges can be selected.) • It can be used to wake up the device from different standby modes. 					
On-chip debug	<ul style="list-style-type: none"> • 1-wire serial control • It supports serial writing (asynchronous mode). 					

(Continued)

Part number	MB95F613H	MB95F614H	MB95F616H	MB95F613K	MB95F614K	MB95F616K
Parameter						
UART/SIO	2 channels <ul style="list-style-type: none"> Data transfer with UART/SIO is enabled. It has a full duplex double buffer, variable data length (5/6/7/8 bits), an internal baud rate generator and an error detection function. It uses the NRZ type transfer format. LSB-first data transfer and MSB-first data transfer are available to use. Clock-asynchronized (UART) serial data transfer and clock-synchronized (SIO) serial data transfer is enabled. 					
I ² C bus interface	1 channel <ul style="list-style-type: none"> Master/slave transmission and receiving It has the following functions: bus error function, arbitration function, transmission direction detection function, wake-up function, and functions of generating and detecting repeated START conditions. 					
8/16-bit PPG	2 channels <ul style="list-style-type: none"> Each channel can be used as an "8-bit timer × 2 channels" or a "16-bit timer × 1 channel". The counter operating clock can be selected from eight clock sources. 					
16-bit reload timer	1 channel <ul style="list-style-type: none"> Two clock modes and two counter operating modes are available to use. It can output square wave. Count clock: it can be selected from internal clocks (seven types) and external clocks. Two counter operating modes: reload mode and one-shot mode 					
Event counter	By configuring the 16-bit reload timer and 8/16-bit composite timer ch. 1, the event count function can be implemented. When the event counter function is used, the 16-bit reload timer and 8/16-bit composite timer ch. 1 become unavailable.					
LCDC controller (LCDC)	<ul style="list-style-type: none"> COM output: 4 or 8 (max) (selectable) SEG output: 48 or 52 (max) (selectable) <ul style="list-style-type: none"> If the number of COM outputs is 4, the maximum number of SEG outputs is 52, and the maximum number of pixels that can be displayed 208 (4 × 52). If the number of COM outputs is 8, the maximum number of SEG outputs is 48, and the maximum number of pixels that can be displayed 384 (8 × 48). Duty LCD mode LCD standby mode Blinking function Internal divider resistor whose resistance value can be selected from 10 kΩ or 100 kΩ through software Interrupt in sync with the LCD module frame frequency Inverted display function 					
Watch counter	<ul style="list-style-type: none"> Count clock: four selectable clock sources (125 ms, 250 ms, 500 ms or 1 s) The counter value can be selected from 0 to 63. (The watch counter can count for one minute when the clock source is one second and the counter value is set to 60.) 					
Watch prescaler	Eight different time intervals can be selected.					

(Continued)

(Continued)

Part number	MB95F613H	MB95F614H	MB95F616H	MB95F613K	MB95F614K	MB95F616K								
Parameter														
Flash memory	<ul style="list-style-type: none"> It supports automatic programming (Embedded Algorithm), and program/erase/erase-suspend/erase-resume commands. It has a flag indicating the completion of the operation of Embedded Algorithm. Flash security feature for protecting the content of the Flash memory <table border="1"> <tr> <td>Number of program/erase cycles</td> <td>1000</td> <td>10000</td> <td>100000</td> </tr> <tr> <td>Data retention time</td> <td>20 years</td> <td>10 years</td> <td>5 years</td> </tr> </table>						Number of program/erase cycles	1000	10000	100000	Data retention time	20 years	10 years	5 years
Number of program/erase cycles	1000	10000	100000											
Data retention time	20 years	10 years	5 years											
Standby mode	<p>There are four standby modes as follows:</p> <ul style="list-style-type: none"> Stop mode Sleep mode Watch mode Time-base timer mode <p>In standby mode, two further options can be selected: normal standby mode and deep standby mode.</p>													
Package	FPT-80P-M37													

■ PACKAGES AND CORRESPONDING PRODUCTS

Part number / Package	MB95F613H	MB95F614H	MB95F616H	MB95F613K	MB95F614K	MB95F616K
FPT-80P-M37	O	O	O	O	O	O

O: Available

■ DIFFERENCES AMONG PRODUCTS AND NOTES ON PRODUCT SELECTION

- Current consumption
When using the on-chip debug function, take account of the current consumption of Flash program/erase.
For details of current consumption, see “■ ELECTRICAL CHARACTERISTICS”.
- Package
For details of information on each package, see “■ PACKAGES AND CORRESPONDING PRODUCTS” and “■ PACKAGE DIMENSION”.
- Operating voltage
The operating voltage varies, depending on whether the on-chip debug function is used or not.
For details of operating voltage, see “■ ELECTRICAL CHARACTERISTICS”.
- On-chip debug function
The on-chip debug function requires that V_{CC} , V_{SS} and one serial wire be connected to an evaluation tool.
For details of the connection method, refer to “CHAPTER 25 EXAMPLE OF SERIAL PROGRAMMING CONNECTION” in the hardware manual of the MB95610H Series.

■ PIN ASSIGNMENT

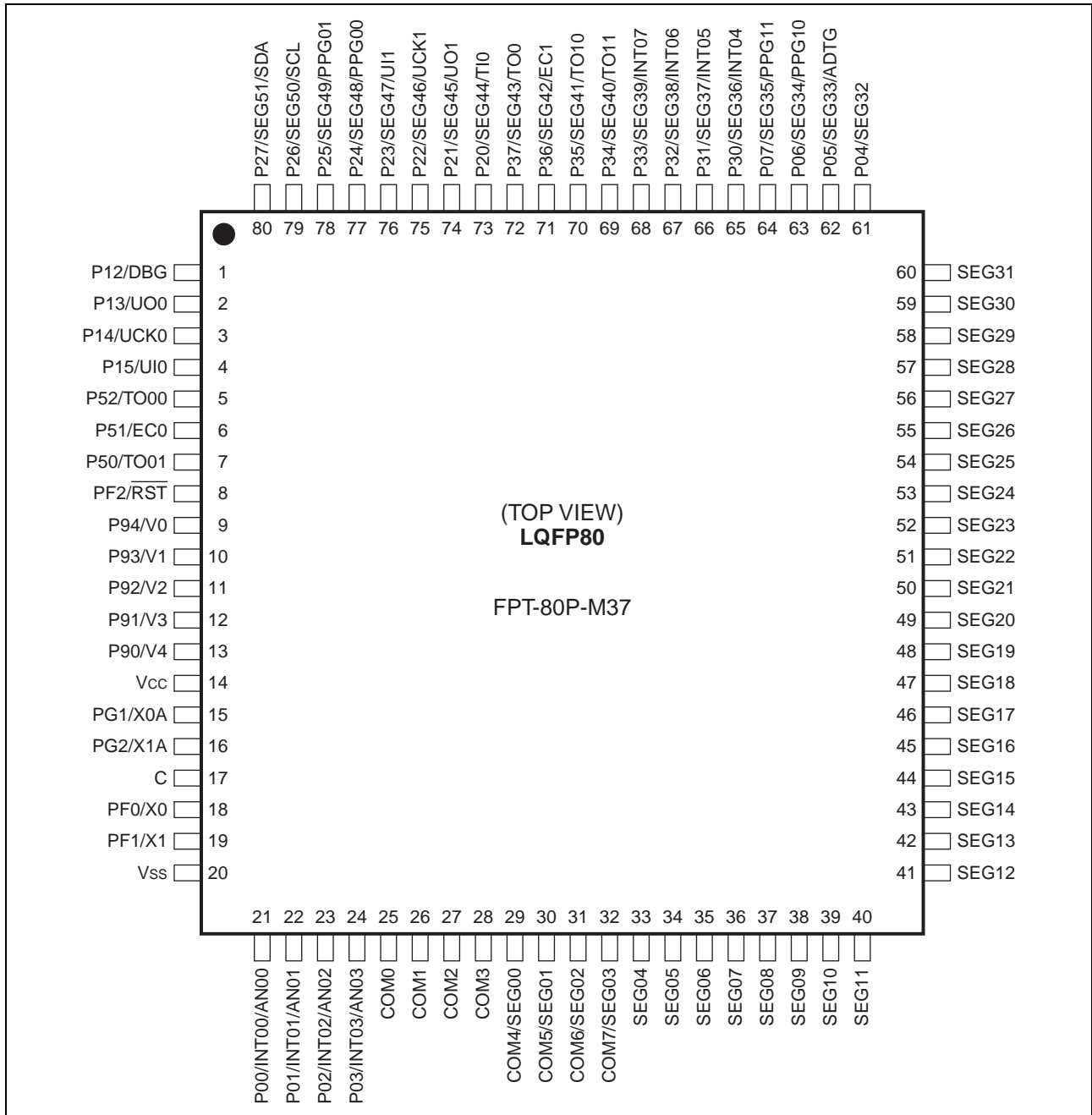

■ PIN FUNCTIONS

Pin no.	Pin name	I/O circuit type*1	Function	I/O type			
				Input	Output	OD*2	PU*3
1	P12	A	General-purpose I/O port	Hysteresis	CMOS	O	—
	DBG		DBG input pin				
2	P13	B	General-purpose I/O port	Hysteresis	CMOS	—	O
	UO0		UART/SIO ch. 0 data output pin				
3	P14	B	General-purpose I/O port	Hysteresis	CMOS	—	O
	UCK0		UART/SIO ch. 0 clock I/O pin				
4	P15	B	General-purpose I/O port	Hysteresis	CMOS	—	O
	UI0		UART/SIO ch. 0 data input pin				
5	P52	B	General-purpose I/O port	Hysteresis	CMOS	—	O
	TO00		8/16-bit composite timer ch. 0 output pin				
6	P51	B	General-purpose I/O port	Hysteresis	CMOS	—	O
	EC0		8/16-bit composite timer ch. 0 clock input pin				
7	P50	B	General-purpose I/O port	Hysteresis	CMOS	—	O
	TO01		8/16-bit composite timer ch. 0 output pin				
8	PF2	C	General-purpose I/O port	Hysteresis	CMOS	O	—
	RST		Reset pin Dedicated reset pin on MB95F613H/F614H/F616H				
9	P94	D	General-purpose I/O port	Hysteresis	CMOS	—	—
	V0		LCD drive power supply pin				
10	P93	D	General-purpose I/O port	Hysteresis	CMOS	—	—
	V1		LCD drive power supply pin				
11	P92	D	General-purpose I/O port	Hysteresis	CMOS	—	—
	V2		LCD drive power supply pin				
12	P91	D	General-purpose I/O port	Hysteresis	CMOS	—	—
	V3		LCD drive power supply pin				
13	P90	D	General-purpose I/O port	Hysteresis	CMOS	—	—
	V4		LCD drive power supply pin				
14	Vcc	—	Power supply pin	—	—	—	—
15	PG1	E	General-purpose I/O port	Hysteresis	CMOS	—	O
	X0A		Subclock input oscillation pin (32 kHz)				
16	PG2	E	General-purpose I/O port	Hysteresis	CMOS	—	O
	X1A		Subclock I/O oscillation pin (32 kHz)				
17	C	—	Decoupling capacitor connection pin	—	—	—	—
18	PF0	F	General-purpose I/O port	Hysteresis	CMOS	—	—
	X0		Main clock input oscillation pin				
19	PF1	F	General-purpose I/O port	Hysteresis	CMOS	—	—
	X1		Main clock I/O oscillation pin				
20	Vss	—	Power supply pin (GND)	—	—	—	—

(Continued)

Pin no.	Pin name	I/O circuit type*1	Function	I/O type			
				Input	Output	OD*2	PU*3
21	P00	G	General-purpose I/O port	Hysteresis/ analog	CMOS	—	—
	INT00		External interrupt input pin				
	AN00		8/10-bit A/D converter analog input pin				
22	P01	G	General-purpose I/O port	Hysteresis/ analog	CMOS	—	—
	INT01		External interrupt input pin				
	AN01		8/10-bit A/D converter analog input pin				
23	P02	G	General-purpose I/O port	Hysteresis/ analog	CMOS	—	—
	INT02		External interrupt input pin				
	AN02		8/10-bit A/D converter analog input pin				
24	P03	G	General-purpose I/O port	Hysteresis/ analog	CMOS	—	—
	INT03		External interrupt input pin				
	AN03		8/10-bit A/D converter analog input pin				
25	COM0	H	LCDC COM0 output pin	Hysteresis	LCD	—	—
26	COM1	H	LCDC COM1 output pin	Hysteresis	LCD	—	—
27	COM2	H	LCDC COM2 output pin	Hysteresis	LCD	—	—
28	COM3	H	LCDC COM3 output pin	Hysteresis	LCD	—	—
29	COM4	H	LCDC COM4 output pin	Hysteresis	LCD	—	—
	SEG00		LCDC SEG00 output pin				
30	COM5	H	LCDC COM5 output pin	Hysteresis	LCD	—	—
	SEG01		LCDC SEG01 output pin				
31	COM6	H	LCDC COM6 output pin	Hysteresis	LCD	—	—
	SEG02		LCDC SEG02 output pin				
32	COM7	H	LCDC COM7 output pin	Hysteresis	LCD	—	—
	SEG03		LCDC SEG03 output pin				
33	SEG04	H	LCDC SEG04 output pin	Hysteresis	LCD	—	—
34	SEG05	H	LCDC SEG05 output pin	Hysteresis	LCD	—	—
35	SEG06	H	LCDC SEG06 output pin	Hysteresis	LCD	—	—
36	SEG07	H	LCDC SEG07 output pin	Hysteresis	LCD	—	—
37	SEG08	H	LCDC SEG08 output pin	Hysteresis	LCD	—	—
38	SEG09	H	LCDC SEG09 output pin	Hysteresis	LCD	—	—
39	SEG10	H	LCDC SEG10 output pin	Hysteresis	LCD	—	—
40	SEG11	H	LCDC SEG11 output pin	Hysteresis	LCD	—	—
41	SEG12	H	LCDC SEG12 output pin	Hysteresis	LCD	—	—
42	SEG13	H	LCDC SEG13 output pin	Hysteresis	LCD	—	—
43	SEG14	H	LCDC SEG14 output pin	Hysteresis	LCD	—	—
44	SEG15	H	LCDC SEG15 output pin	Hysteresis	LCD	—	—
45	SEG16	H	LCDC SEG16 output pin	Hysteresis	LCD	—	—
46	SEG17	H	LCDC SEG17 output pin	Hysteresis	LCD	—	—
47	SEG18	H	LCDC SEG18 output pin	Hysteresis	LCD	—	—
48	SEG19	H	LCDC SEG19 output pin	Hysteresis	LCD	—	—

(Continued)

Pin no.	Pin name	I/O circuit type*1	Function	I/O type			
				Input	Output	OD*2	PU*3
49	SEG20	H	LCDC SEG20 output pin	Hysteresis	LCD	—	—
50	SEG21	H	LCDC SEG21 output pin	Hysteresis	LCD	—	—
51	SEG22	H	LCDC SEG22 output pin	Hysteresis	LCD	—	—
52	SEG23	H	LCDC SEG23 output pin	Hysteresis	LCD	—	—
53	SEG24	H	LCDC SEG24 output pin	Hysteresis	LCD	—	—
54	SEG25	H	LCDC SEG25 output pin	Hysteresis	LCD	—	—
55	SEG26	H	LCDC SEG26 output pin	Hysteresis	LCD	—	—
56	SEG27	H	LCDC SEG27 output pin	Hysteresis	LCD	—	—
57	SEG28	H	LCDC SEG28 output pin	Hysteresis	LCD	—	—
58	SEG29	H	LCDC SEG29 output pin	Hysteresis	LCD	—	—
59	SEG30	H	LCDC SEG30 output pin	Hysteresis	LCD	—	—
60	SEG31	H	LCDC SEG31 output pin	Hysteresis	LCD	—	—
61	P04	I	General-purpose I/O port	Hysteresis	CMOS/ LCD	—	—
	SEG32		LCDC SEG32 output pin				
62	P05	I	General-purpose I/O port	Hysteresis	CMOS/ LCD	—	—
	SEG33		LCDC SEG33 output pin				
	ADTG		8/10-bit A/D converter trigger input pin				
63	P06	I	General-purpose I/O port	Hysteresis	CMOS/ LCD	—	—
	SEG34		LCDC SEG34 output pin				
	PPG10		8/16-bit PPG ch. 1 output pin				
64	P07	I	General-purpose I/O port	Hysteresis	CMOS/ LCD	—	—
	SEG35		LCDC SEG35 output pin				
	PPG11		8/16-bit PPG ch. 1 output pin				
65	P30	I	General-purpose I/O port	Hysteresis	CMOS/ LCD	—	—
	SEG36		LCDC SEG36 output pin				
	INT04		External interrupt input pin				
66	P31	I	General-purpose I/O port	Hysteresis	CMOS/ LCD	—	—
	SEG37		LCDC SEG37 output pin				
	INT05		External interrupt input pin				
67	P32	I	General-purpose I/O port	Hysteresis	CMOS/ LCD	—	—
	SEG38		LCDC SEG38 output pin				
	INT06		External interrupt input pin				
68	P33	I	General-purpose I/O port	Hysteresis	CMOS/ LCD	—	—
	SEG39		LCDC SEG39 output pin				
	INT07		External interrupt input pin				
69	P34	I	General-purpose I/O port	Hysteresis	CMOS/ LCD	—	—
	SEG40		LCDC SEG40 output pin				
	TO11		8/16-bit composite timer ch. 1 output pin				

(Continued)

(Continued)

Pin no.	Pin name	I/O circuit type*1	Function	I/O type			
				Input	Output	OD*2	PU*3
70	P35	I	General-purpose I/O port	Hysteresis	CMOS/ LCD	—	—
	SEG41		LCDC SEG41 output pin				
	TO10		8/16-bit composite timer ch. 1 output pin				
71	P36	I	General-purpose I/O port	Hysteresis	CMOS/ LCD	—	—
	SEG42		LCDC SEG42 output pin				
	EC1		8/16-bit composite timer ch. 1 clock input pin				
72	P37	I	General-purpose I/O port	Hysteresis	CMOS/ LCD	—	—
	SEG43		LCDC SEG43 output pin				
	TO0		16-bit reload timer ch. 0 output pin				
73	P20	I	General-purpose I/O port	Hysteresis	CMOS/ LCD	—	—
	SEG44		LCDC SEG44 output pin				
	TI0		16-bit reload timer ch. 0 input pin				
74	P21	I	General-purpose I/O port	Hysteresis	CMOS/ LCD	—	—
	SEG45		LCDC SEG45 output pin				
	UO1		UART/SIO ch. 1 data output pin				
75	P22	I	General-purpose I/O port	Hysteresis	CMOS/ LCD	—	—
	SEG46		LCDC SEG46 output pin				
	UCK1		UART/SIO ch. 1 clock I/O pin				
76	P23	I	General-purpose I/O port	Hysteresis	CMOS/ LCD	—	—
	SEG47		LCDC SEG47 output pin				
	UI1		UART/SIO ch. 1 data input pin				
77	P24	I	General-purpose I/O port	Hysteresis	CMOS/ LCD	—	—
	SEG48		LCDC SEG48 output pin				
	PPG00		8/16-bit PPG ch. 0 output pin				
78	P25	I	General-purpose I/O port	Hysteresis	CMOS/ LCD	—	—
	SEG49		LCDC SEG49 output pin				
	PPG01		8/16-bit PPG ch. 0 output pin				
79	P26	I	General-purpose I/O port	Hysteresis	CMOS/ LCD	—	—
	SEG50		LCDC SEG50 output pin				
	SCL		I ² C bus interface ch. 0 clock I/O pin				
80	P27	I	General-purpose I/O port	Hysteresis	CMOS/ LCD	—	—
	SEG51		LCDC SEG51 output pin				
	SDA		I ² C bus interface ch. 0 data I/O pin				

(O: Available)

*1: For the I/O circuit types, see “■ I/O CIRCUIT TYPE”.

*2: N-ch open drain

*3: Pull-up

■ I/O CIRCUIT TYPE

Type	Circuit	Remarks
A	<p>Standby control Hysteresis input Digital output N-ch</p>	<ul style="list-style-type: none"> • N-ch open drain output • Hysteresis input
B	<p>Pull-up control Digital output Digital output N-ch Standby control Hysteresis input</p>	<ul style="list-style-type: none"> • CMOS output • Hysteresis input • Pull-up control
C	<p>Reset input / Hysteresis input Reset output / Digital output N-ch</p>	<ul style="list-style-type: none"> • N-ch open drain output • Hysteresis input • Reset output
D	<p>Digital output Digital output N-ch LCD internal divider resistor I/O LCD control Standby control Hysteresis input</p>	<ul style="list-style-type: none"> • CMOS output • LCD power supply • Hysteresis input
E	<p>Port select Digital output Digital output Standby control Hysteresis input Clock input X1 X0 Standby control / Port select Port select Digital output Digital output Standby control Hysteresis input</p>	<ul style="list-style-type: none"> • Oscillation circuit • High-speed side Feedback resistance: approx. 1 MΩ • CMOS output • Hysteresis input

(Continued)

(Continued)

Type	Circuit	Remarks
F		<ul style="list-style-type: none"> • Oscillation circuit • Low-speed side Feedback resistance: approx. 10 MΩ • CMOS output • Hysteresis input • Pull-up control
G		<ul style="list-style-type: none"> • CMOS output • Hysteresis input • Analog input
H		<ul style="list-style-type: none"> • LCD output
I		<ul style="list-style-type: none"> • CMOS output • LCD output • Hysteresis input

■ HANDLING PRECAUTIONS

Any semiconductor devices have inherently a certain rate of failure. The possibility of failure is greatly affected by the conditions in which they are used (circuit conditions, environmental conditions, etc.). This page describes precautions that must be observed to minimize the chance of failure and to obtain higher reliability from your FUJITSU SEMICONDUCTOR semiconductor devices.

1. Precautions for Product Design

This section describes precautions when designing electronic equipment using semiconductor devices.

• Absolute Maximum Ratings

Semiconductor devices can be permanently damaged by application of stress (voltage, current, temperature, etc.) in excess of certain established limits, called absolute maximum ratings. Do not exceed these ratings.

• Recommended Operating Conditions

Recommended operating conditions are normal operating ranges for the semiconductor device. All the device's electrical characteristics are warranted when operated within these ranges.

Always use semiconductor devices within the recommended operating conditions. Operation outside these ranges may adversely affect reliability and could result in device failure.

No warranty is made with respect to uses, operating conditions, or combinations not represented on the data sheet. Users considering application outside the listed conditions are advised to contact their sales representative beforehand.

• Processing and Protection of Pins

These precautions must be followed when handling the pins which connect semiconductor devices to power supply and input/output functions.

(1) Preventing Over-Voltage and Over-Current Conditions

Exposure to voltage or current levels in excess of maximum ratings at any pin is likely to cause deterioration within the device, and in extreme cases leads to permanent damage of the device. Try to prevent such overvoltage or over-current conditions at the design stage.

(2) Protection of Output Pins

Shorting of output pins to supply pins or other output pins, or connection to large capacitance can cause large current flows. Such conditions if present for extended periods of time can damage the device.

Therefore, avoid this type of connection.

(3) Handling of Unused Input Pins

Unconnected input pins with very high impedance levels can adversely affect stability of operation. Such pins should be connected through an appropriate resistance to a power supply pin or ground pin.

- **Latch-up**

Semiconductor devices are constructed by the formation of P-type and N-type areas on a substrate. When subjected to abnormally high voltages, internal parasitic PNP junctions (called thyristor structures) may be formed, causing large current levels in excess of several hundred mA to flow continuously at the power supply pin. This condition is called latch-up.

CAUTION: The occurrence of latch-up not only causes loss of reliability in the semiconductor device, but can cause injury or damage from high heat, smoke or flame. To prevent this from happening, do the following:

- (1) Be sure that voltages applied to pins do not exceed the absolute maximum ratings. This should include attention to abnormal noise, surge levels, etc.
- (2) Be sure that abnormal current flows do not occur during the power-on sequence.

- **Observance of Safety Regulations and Standards**

Most countries in the world have established standards and regulations regarding safety, protection from electromagnetic interference, etc. Customers are requested to observe applicable regulations and standards in the design of products.

- **Fail-Safe Design**

Any semiconductor devices have inherently a certain rate of failure. You must protect against injury, damage or loss from such failures by incorporating safety design measures into your facility and equipment such as redundancy, fire protection, and prevention of over-current levels and other abnormal operating conditions.

- **Precautions Related to Usage of Devices**

FUJITSU SEMICONDUCTOR semiconductor devices are intended for use in standard applications (computers, office automation and other office equipment, industrial, communications, and measurement equipment, personal or household devices, etc.).

CAUTION: Customers considering the use of our products in special applications where failure or abnormal operation may directly affect human lives or cause physical injury or property damage, or where extremely high levels of reliability are demanded (such as aerospace systems, atomic energy controls, sea floor repeaters, vehicle operating controls, medical devices for life support, etc.) are requested to consult with sales representatives before such use. The company will not be responsible for damages arising from such use without prior approval.

2. Precautions for Package Mounting

Package mounting may be either lead insertion type or surface mount type. In either case, for heat resistance during soldering, you should only mount under FUJITSU SEMICONDUCTOR's recommended conditions. For detailed information about mount conditions, contact your sales representative.

- **Lead Insertion Type**

Mounting of lead insertion type packages onto printed circuit boards may be done by two methods: direct soldering on the board, or mounting by using a socket.

Direct mounting onto boards normally involves processes for inserting leads into through-holes on the board and using the flow soldering (wave soldering) method of applying liquid solder. In this case, the soldering process usually causes leads to be subjected to thermal stress in excess of the absolute ratings for storage temperature. Mounting processes should conform to FUJITSU SEMICONDUCTOR recommended mounting conditions.

If socket mounting is used, differences in surface treatment of the socket contacts and IC lead surfaces can lead to contact deterioration after long periods. For this reason it is recommended that the surface treatment of socket contacts and IC leads be verified before mounting.

• Surface Mount Type

Surface mount packaging has longer and thinner leads than lead-insertion packaging, and therefore leads are more easily deformed or bent. The use of packages with higher pin counts and narrower pin pitch results in increased susceptibility to open connections caused by deformed pins, or shorting due to solder bridges.

You must use appropriate mounting techniques. FUJITSU SEMICONDUCTOR recommends the solder reflow method, and has established a ranking of mounting conditions for each product. Users are advised to mount packages in accordance with FUJITSU SEMICONDUCTOR ranking of recommended conditions.

• Lead-Free Packaging

CAUTION: When ball grid array (BGA) packages with Sn-Ag-Cu balls are mounted using Sn-Pb eutectic soldering, junction strength may be reduced under some conditions of use.

• Storage of Semiconductor Devices

Because plastic chip packages are formed from plastic resins, exposure to natural environmental conditions will cause absorption of moisture. During mounting, the application of heat to a package that has absorbed moisture can cause surfaces to peel, reducing moisture resistance and causing packages to crack. To prevent, do the following:

- (1) Avoid exposure to rapid temperature changes, which cause moisture to condense inside the product. Store products in locations where temperature changes are slight.
- (2) Use dry boxes for product storage. Products should be stored below 70% relative humidity, and at temperatures between 5 °C and 30 °C.
When you open Dry Package that recommends humidity 40% to 70% relative humidity.
- (3) When necessary, FUJITSU SEMICONDUCTOR packages semiconductor devices in highly moisture-resistant aluminum laminate bags, with a silica gel desiccant. Devices should be sealed in their aluminum laminate bags for storage.
- (4) Avoid storing packages where they are exposed to corrosive gases or high levels of dust.

• Baking

Packages that have absorbed moisture may be de-moisturized by baking (heat drying). Follow the FUJITSU SEMICONDUCTOR recommended conditions for baking.

Condition: 125 °C/24 h

• Static Electricity

Because semiconductor devices are particularly susceptible to damage by static electricity, you must take the following precautions:

- (1) Maintain relative humidity in the working environment between 40% and 70%.
Use of an apparatus for ion generation may be needed to remove electricity.
- (2) Electrically ground all conveyors, solder vessels, soldering irons and peripheral equipment.
- (3) Eliminate static body electricity by the use of rings or bracelets connected to ground through high resistance (on the level of 1 MΩ).
Wearing of conductive clothing and shoes, use of conductive floor mats and other measures to minimize shock loads is recommended.
- (4) Ground all fixtures and instruments, or protect with anti-static measures.
- (5) Avoid the use of styrofoam or other highly static-prone materials for storage of completed board assemblies.

3. Precautions for Use Environment

Reliability of semiconductor devices depends on ambient temperature and other conditions as described above.

For reliable performance, do the following:

(1) Humidity

Prolonged use in high humidity can lead to leakage in devices as well as printed circuit boards. If high humidity levels are anticipated, consider anti-humidity processing.

(2) Discharge of Static Electricity

When high-voltage charges exist close to semiconductor devices, discharges can cause abnormal operation. In such cases, use anti-static measures or processing to prevent discharges.

(3) Corrosive Gases, Dust, or Oil

Exposure to corrosive gases or contact with dust or oil may lead to chemical reactions that will adversely affect the device. If you use devices in such conditions, consider ways to prevent such exposure or to protect the devices.

(4) Radiation, Including Cosmic Radiation

Most devices are not designed for environments involving exposure to radiation or cosmic radiation. Users should provide shielding as appropriate.

(5) Smoke, Flame

CAUTION: Plastic molded devices are flammable, and therefore should not be used near combustible substances. If devices begin to smoke or burn, there is danger of the release of toxic gases.

Customers considering the use of FUJITSU SEMICONDUCTOR products in other special environmental conditions should consult with sales representatives.

Please check the latest handling precautions at the following URL.
<http://edevice.fujitsu.com/fj/handling-e.pdf>

■ NOTES ON DEVICE HANDLING

• Preventing latch-ups

When using the device, ensure that the voltage applied does not exceed the maximum voltage rating.

In a CMOS IC, if a voltage higher than V_{CC} or a voltage lower than V_{SS} is applied to an input/output pin that is neither a medium-withstand voltage pin nor a high-withstand voltage pin, or if a voltage out of the rating range of power supply voltage mentioned in “1. Absolute Maximum Ratings” of “■ ELECTRICAL CHARACTERISTICS” is applied to the V_{CC} pin or the V_{SS} pin, a latch-up may occur.

When a latch-up occurs, power supply current increases significantly, which may cause a component to be thermally destroyed.

• Stabilizing supply voltage

Supply voltage must be stabilized.

A malfunction may occur when power supply voltage fluctuates rapidly even though the fluctuation is within the guaranteed operating range of the V_{CC} power supply voltage.

As a rule of voltage stabilization, suppress voltage fluctuation so that the fluctuation in V_{CC} ripple (p-p value) at the commercial frequency (50 Hz/60 Hz) does not exceed 10% of the standard V_{CC} value, and the transient fluctuation rate does not exceed 0.1 V/ms at a momentary fluctuation such as switching the power supply.

• Notes on using the external clock

When an external clock is used, oscillation stabilization wait time is required for power-on reset, wake-up from subclock mode or stop mode.

■ PIN CONNECTION

• Treatment of unused pins

If an unused input pin is left unconnected, a component may be permanently damaged due to malfunctions or latch-ups. Always pull up or pull down an unused input pin through a resistor of at least 2 k Ω . Set an unused input/output pin to the output state and leave it unconnected, or set it to the input state and treat it the same as an unused input pin. If there is an unused output pin, leave it unconnected.

• Power supply pins

To reduce unnecessary electro-magnetic emission, prevent malfunctions of strobe signals due to an increase in the ground level, and conform to the total output current standard, always connect the V_{CC} pin and the V_{SS} pin to the power supply and ground outside the device. In addition, connect the current supply source to the V_{CC} pin and the V_{SS} pin with low impedance.

It is also advisable to connect a ceramic capacitor of approximately 0.1 μ F as a decoupling capacitor between the V_{CC} pin and the V_{SS} pin at a location close to this device.

• DBG pin

Connect the DBG pin directly to an external pull-up resistor.

To prevent the device from unintentionally entering the debug mode due to noise, minimize the distance between the DBG pin and the V_{CC} or V_{SS} pin when designing the layout of the printed circuit board.

The DBG pin should not stay at “L” level after power-on until the reset output is released.

• \overline{RST} pin

Connect the \overline{RST} pin directly to an external pull-up resistor.

To prevent the device from unintentionally entering the reset mode due to noise, minimize the distance between the \overline{RST} pin and the V_{CC} or V_{SS} pin when designing the layout of the printed circuit board.

The PF2/ \overline{RST} pin functions as the reset input/output pin after power-on. In addition, the reset output of the PF2/ \overline{RST} pin can be enabled by the RSTOE bit in the SYSC register, and the reset input function and the general purpose I/O function can be selected by the RSTEN bit in the SYSC register.

- C pin

Use a ceramic capacitor or a capacitor with equivalent frequency characteristics. The decoupling capacitor for the V_{CC} pin must have a capacitance larger than C_s. For the connection to a decoupling capacitor C_s, see the diagram below. To prevent the device from unintentionally entering a mode to which the device is not set to transit due to noise, minimize the distance between the C pin and C_s and the distance between C_s and the V_{SS} pin when designing the layout of a printed circuit board.

- DBG/ $\overline{\text{RST}}$ /C pins connection diagram

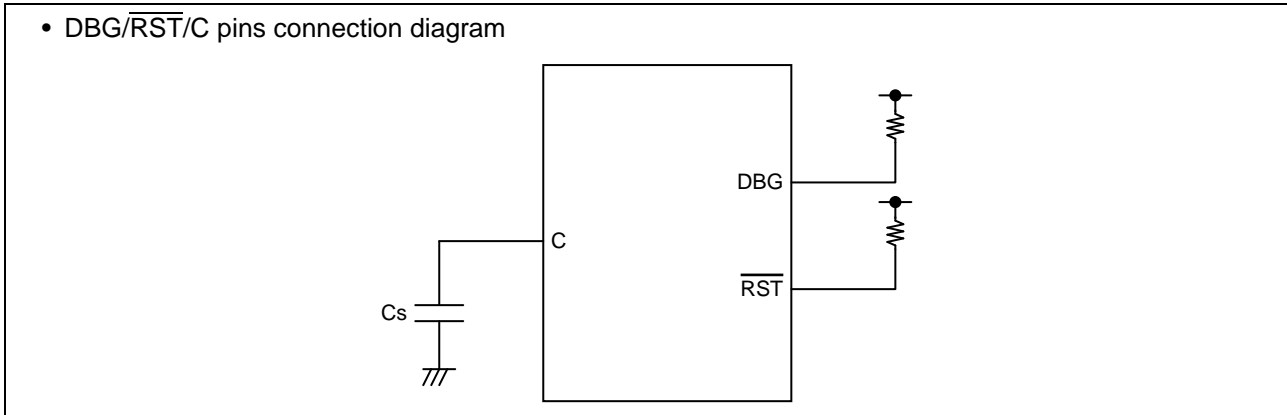

- Note on serial communication

In serial communication, reception of wrong data may occur due to noise or other causes. Therefore, design a printed circuit board to prevent noise from occurring. Taking account of the reception of wrong data, take measures such as adding a checksum to the end of data in order to detect errors. If an error is detected, retransmit the data.

■ BLOCK DIAGRAM

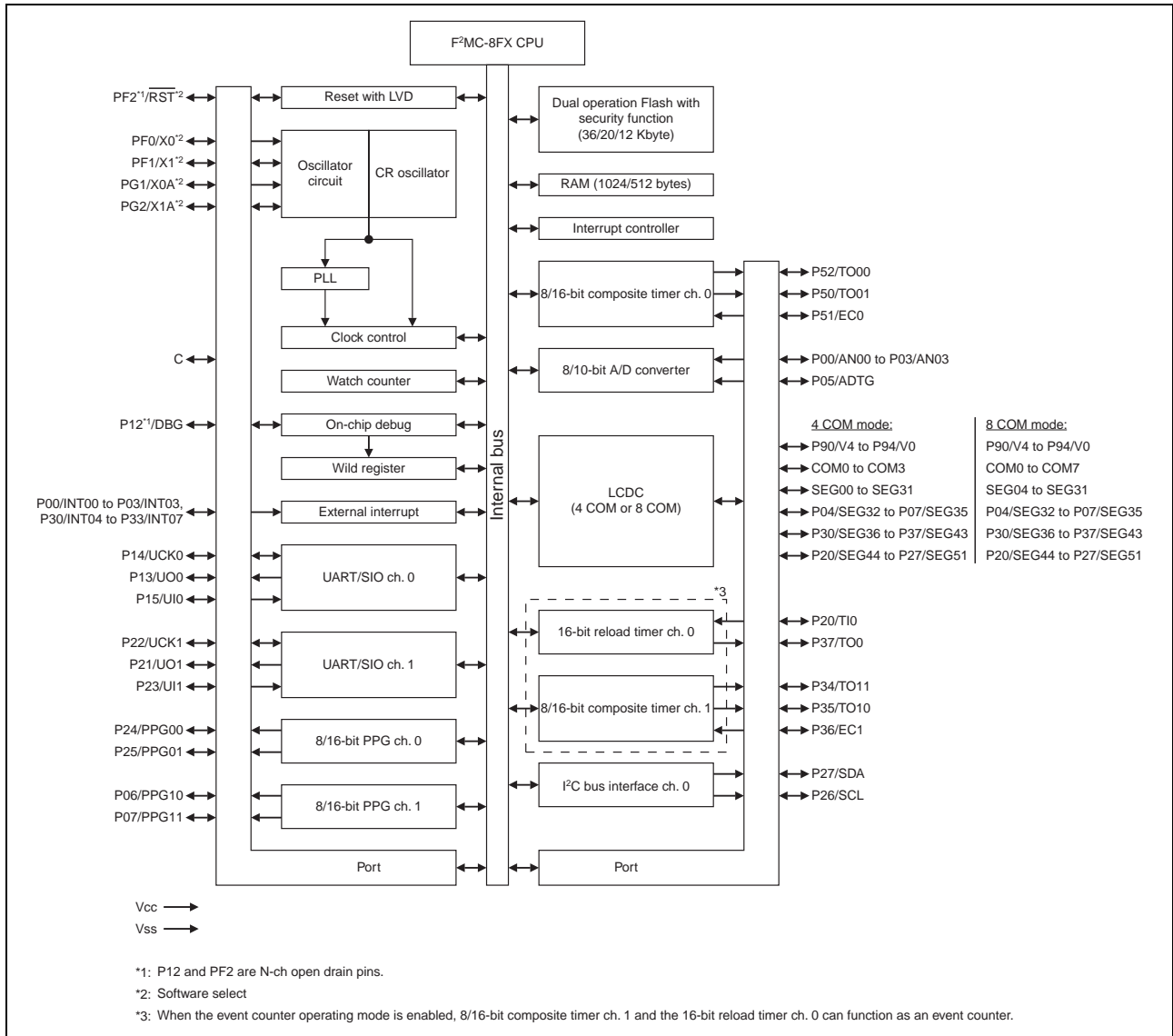

■ CPU CORE

- Memory space

The memory space of the MB95610H Series is 64 Kbyte in size, and consists of an I/O area, an extended I/O area, a data area, and a program area. The memory space includes areas intended for specific purposes such as general-purpose registers and a vector table. The memory maps of the MB95610H Series are shown below.

- Memory maps

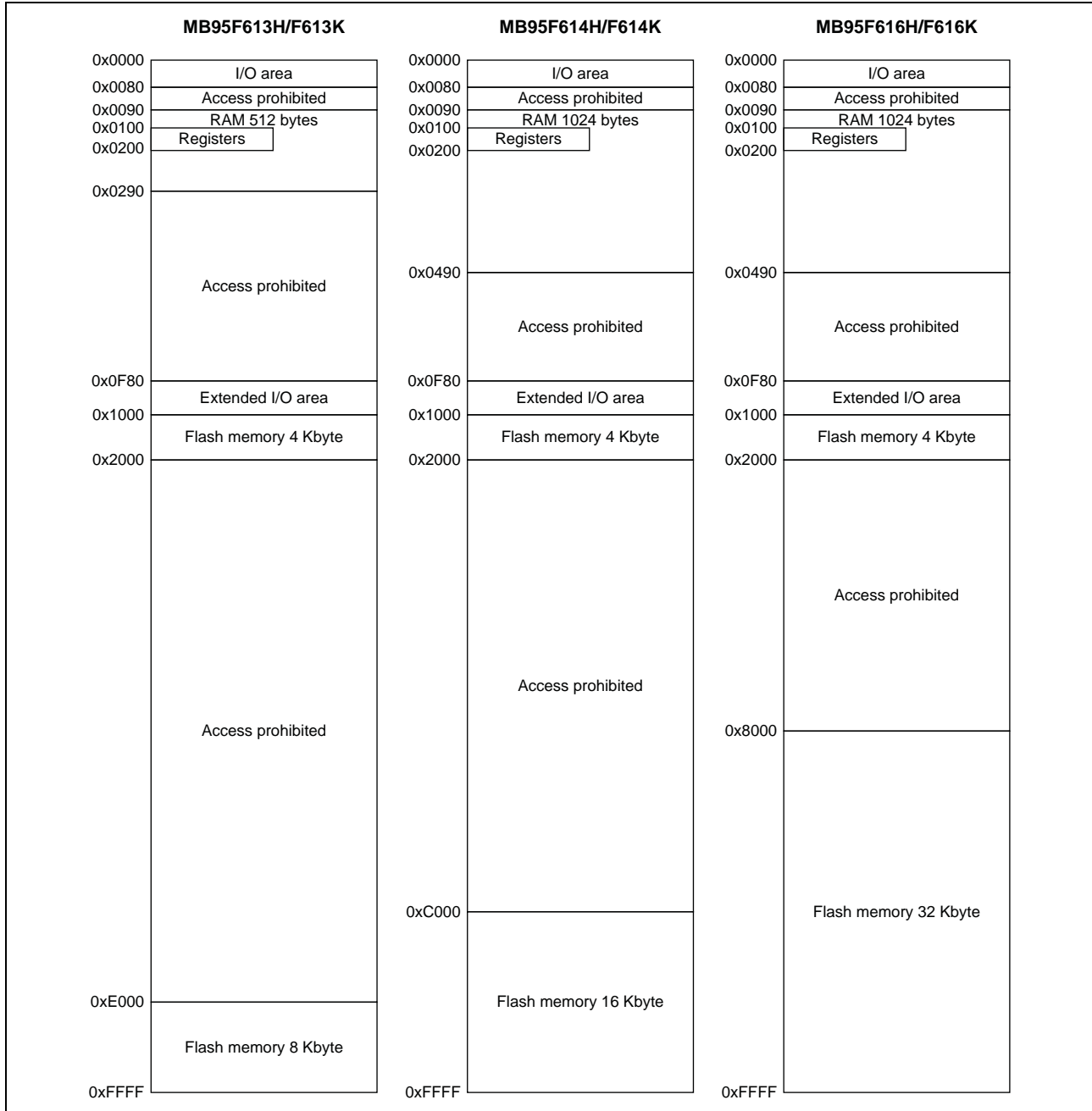

■ MEMORY SPACE

The memory space of the MB95610H Series is 64 Kbyte in size, and consists of an I/O area, an extended I/O area, a data area, and a program area. The memory space includes areas for specific applications such as general-purpose registers and a vector table.

- I/O area (addresses: 0x0000 to 0x007F)
 - This area contains the control registers and data registers for built-in peripheral functions.
 - As the I/O area forms part of the memory space, it can be accessed in the same way as the memory. It can also be accessed at high-speed by using direct addressing instructions.
- Extended I/O area (addresses: 0x0F80 to 0x0FFF)
 - This area contains the control registers and data registers for built-in peripheral functions.
 - As the extended I/O area forms part of the memory space, it can be accessed in the same way as the memory.
- Data area
 - Static RAM is incorporated in the data area as the internal data area.
 - The internal RAM size varies according to product.
 - The RAM area from 0x0090 to 0x00FF can be accessed at high-speed by using direct addressing instructions.
 - In MB95F614H/F614K/F616H/F616K, the area from 0x0090 to 0x047F is an extended direct addressing area. It can be accessed at high-speed by direct addressing instructions with a direct bank pointer set.
 - In MB95F613H/F613K, the area from 0x0090 to 0x028F is an extended direct addressing area. It can be accessed at high-speed by direct addressing instructions with a direct bank pointer set.
 - The area from 0x0100 to 0x01FF can be used as a general-purpose register area.
- Program area
 - The Flash memory is incorporated in the program area as the internal program area.
 - The Flash memory size varies according to product.
 - The area from 0xFFC0 to 0xFFFF is used as the vector table.
 - The area from 0xFFBB to 0xFFBF is used to store data of the non-volatile register.

• Memory space map

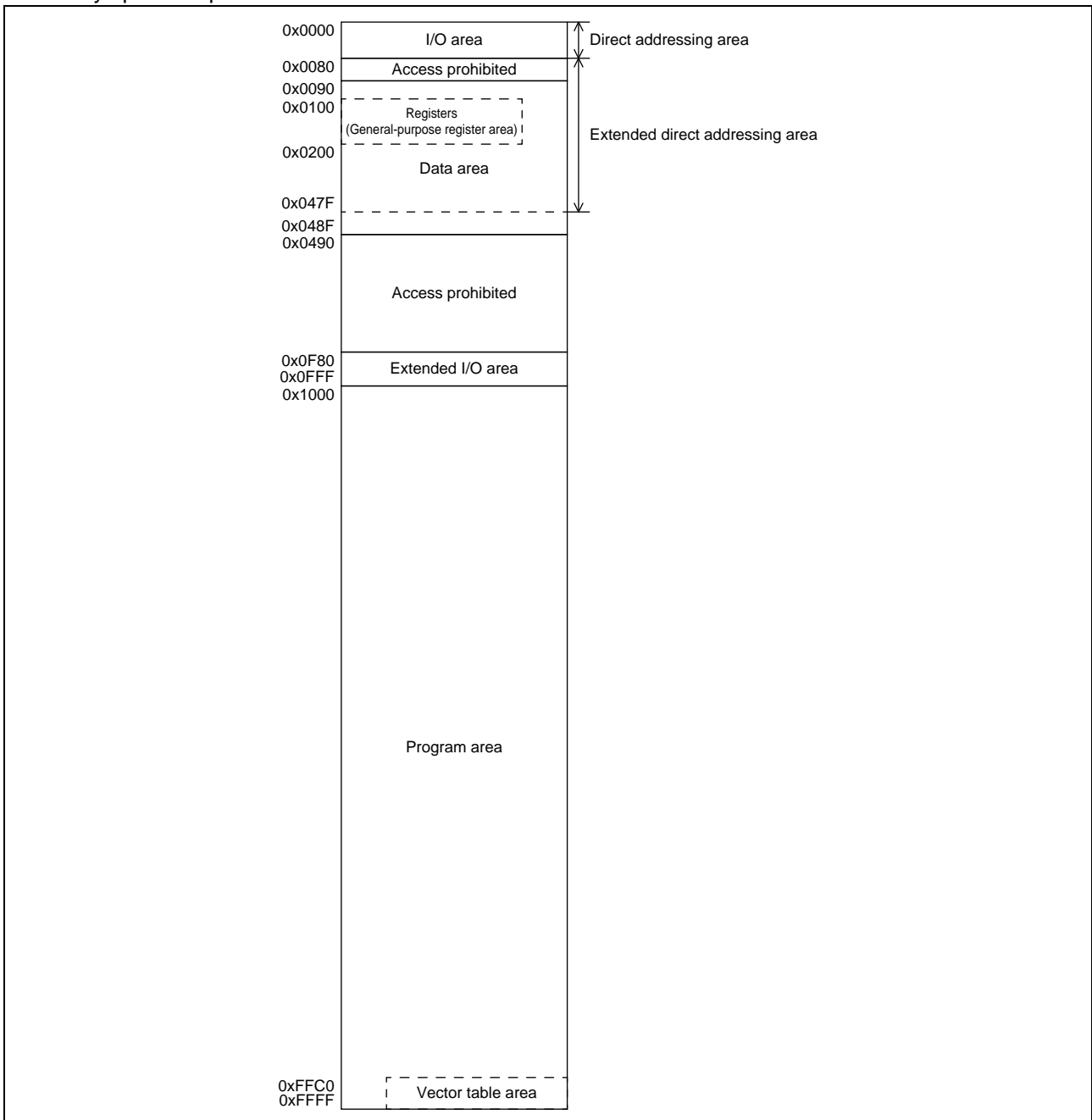

■ AREAS FOR SPECIFIC APPLICATIONS

The general-purpose register area and vector table area are used for the specific applications.

- General-purpose register area (Addresses: 0x0100 to 0x01FF*)
 - This area contains the auxiliary registers used for 8-bit arithmetic operations, transfer, etc.
 - As this area forms part of the RAM area, it can also be used as conventional RAM.
 - When the area is used as general-purpose registers, general-purpose register addressing enables high-speed access with short instructions.
- Non-volatile register data area (Addresses: 0xFFBB to 0xFFBF)
 - The area from 0xFFBB to 0xFFBF is used to store data of the non-volatile register. For details, refer to “CHAPTER 27 NON-VOLATILE REGISTER (NVR) INTERFACE” in the hardware manual of the MB95610H Series.
- Vector table area (Addresses: 0xFFC0 to 0xFFFF)
 - This area is used as the vector table for vector call instructions (CALLV), interrupts, and resets.
 - The top of the Flash memory area is allocated to the vector table area. The start address of a service routine is set to an address in the vector table in the form of data.

“■ INTERRUPT SOURCE TABLE” lists the vector table addresses corresponding to vector call instructions, interrupts, and resets.

For details, refer to “CHAPTER 4 RESET”, “CHAPTER 5 INTERRUPTS”, and “A.2 Special Instruction

■ Special Instruction ● CALLV #vct” in “APPENDIX” in the hardware manual of the MB95610H Series.

- Direct bank pointer and access area

Direct bank pointer (DP[2:0])	Operand-specified dir	Access area
0bXXX (It does not affect mapping.)	0x0000 to 0x007F	0x0000 to 0x007F
0b000 (initial value)	0x0090 to 0x00FF	0x0090 to 0x00FF
0b001	0x0080 to 0x00FF	0x0100 to 0x017F
0b010		0x0180 to 0x01FF
0b011		0x0200 to 0x027F
0b100		0x0280 to 0x02FF*
0b101		0x0300 to 0x037F
0b110		0x0380 to 0x03FF
0b111		0x0400 to 0x047F

*: Due to the memory size limit, the available access area is up to “0x028F” in MB95F613H/F613K.

■ I/O MAP

Address	Register abbreviation	Register name	R/W	Initial value
0x0000	PDR0	Port 0 data register	R/W	0b00000000
0x0001	DDR0	Port 0 direction register	R/W	0b00000000
0x0002	PDR1	Port 1 data register	R/W	0b00000000
0x0003	DDR1	Port 1 direction register	R/W	0b00000000
0x0004	—	(Disabled)	—	—
0x0005	WATR	Oscillation stabilization wait time setting register	R/W	0b11111111
0x0006	PLLC	PLL control register	R/W	0b000X0000
0x0007	SYCC	System clock control register	R/W	0bXXX11011
0x0008	STBC	Standby control register	R/W	0b00000000
0x0009	RSRR	Reset source register	R/W	0b000XXXXX
0x000A	TBTC	Time-base timer control register	R/W	0b00000000
0x000B	WPCR	Watch prescaler control register	R/W	0b00000000
0x000C	WDTC	Watchdog timer control register	R/W	0b00XX0000
0x000D	SYCC2	System clock control register 2	R/W	0bXXXX0011
0x000E	PDR2	Port 2 data register	R/W	0b00000000
0x000F	DDR2	Port 2 direction register	R/W	0b00000000
0x0010	PDR3	Port 3 data register	R/W	0b00000000
0x0011	DDR3	Port 3 direction register	R/W	0b00000000
0x0012, 0x0013	—	(Disabled)	—	—
0x0014	PDR5	Port 5 data register	R/W	0b00000000
0x0015	DDR5	Port 5 direction register	R/W	0b00000000
0x0016 to 0x001B	—	(Disabled)	—	—
0x001C	PDR9	Port 9 data register	R/W	0b00000000
0x001D	DDR9	Port 9 direction register	R/W	0b00000000
0x001E	STBC2	Standby control register 2	R/W	0b00000000
0x001F to 0x0027	—	(Disabled)	—	—
0x0028	PDRF	Port F data register	R/W	0b00000000
0x0029	DDRF	Port F direction register	R/W	0b00000000
0x002A	PDRG	Port G data register	R/W	0b00000000
0x002B	DDRG	Port G direction register	R/W	0b00000000
0x002C	—	(Disabled)	—	—
0x002D	PUL1	Port 1 pull-up register	R/W	0b00000000
0x002E to 0x0030	—	(Disabled)	—	—
0x0031	PUL5	Port 5 pull-up register	R/W	0b00000000

(Continued)

Address	Register abbreviation	Register name	R/W	Initial value
0x0032 to 0x0034	—	(Disabled)	—	—
0x0035	PULG	Port G pull-up register	R/W	0b00000000
0x0036	T01CR1	8/16-bit composite timer 01 status control register 1	R/W	0b00000000
0x0037	T00CR1	8/16-bit composite timer 00 status control register 1	R/W	0b00000000
0x0038	T11CR1	8/16-bit composite timer 11 status control register 1	R/W	0b00000000
0x0039	T10CR1	8/16-bit composite timer 10 status control register 1	R/W	0b00000000
0x003A	PC01	8/16-bit PPG timer 01 control register	R/W	0b00000000
0x003B	PC00	8/16-bit PPG timer 00 control register	R/W	0b00000000
0x003C	PC11	8/16-bit PPG timer 11 control register	R/W	0b00000000
0x003D	PC10	8/16-bit PPG timer 10 control register	R/W	0b00000000
0x003E	TMCSRH0	16-bit reload timer control status register (upper) ch. 0	R/W	0b00000000
0x003F	TMCSRL0	16-bit reload timer control status register (lower) ch. 0	R/W	0b00000000
0x0040 to 0x0047	—	(Disabled)	—	—
0x0048	EIC00	External interrupt circuit control register ch. 0/ch. 1	R/W	0b00000000
0x0049	EIC10	External interrupt circuit control register ch. 2/ch. 3	R/W	0b00000000
0x004A	EIC20	External interrupt circuit control register ch. 4/ch. 5	R/W	0b00000000
0x004B	EIC30	External interrupt circuit control register ch. 6/ch. 7	R/W	0b00000000
0x004C, 0x004D	—	(Disabled)	—	—
0x004E	LVDR	LVD reset voltage selection ID register	R/W	0b00000000
0x004F	LCDC2	LCDC control register 2	R/W	0b00010100
0x0050 to 0x0055	—	(Disabled)	—	—
0x0056	SMC10	UART/SIO serial mode control register 1 ch. 0	R/W	0b00000000
0x0057	SMC20	UART/SIO serial mode control register 2 ch. 0	R/W	0b00100000
0x0058	SSR0	UART/SIO serial status and data register ch. 0	R/W	0b00000001
0x0059	TDR0	UART/SIO serial output data register ch. 0	R/W	0b00000000
0x005A	RDR0	UART/SIO serial input data register ch. 0	R	0b00000000
0x005B	SMC11	UART/SIO serial mode control register 1 ch. 1	R/W	0b00000000
0x005C	SMC21	UART/SIO serial mode control register 2 ch. 1	R/W	0b00100000
0x005D	SSR1	UART/SIO serial status and data register ch. 1	R/W	0b00000001
0x005E	TDR1	UART/SIO serial output data register ch. 1	R/W	0b00000000
0x005F	RDR1	UART/SIO serial input data register ch. 1	R	0b00000000
0x0060	IBCR00	I ² C bus control register 0	R/W	0b00000000
0x0061	IBCR10	I ² C bus control register 1	R/W	0b00000000

(Continued)

Address	Register abbreviation	Register name	R/W	Initial value
0x0062	IBSR0	I ² C bus status register	R/W	0b00000000
0x0063	IDDR0	I ² C data register	R/W	0b00000000
0x0064	IAAR0	I ² C address register	R/W	0b00000000
0x0065	ICCR0	I ² C clock control register	R/W	0b00000000
0x0066 to 0x006B	—	(Disabled)	—	—
0x006C	ADC1	8/10-bit A/D converter control register 1	R/W	0b00000000
0x006D	ADC2	8/10-bit A/D converter control register 2	R/W	0b00000000
0x006E	ADDH	8/10-bit A/D converter data register (upper)	R/W	0b00000000
0x006F	ADDL	8/10-bit A/D converter data register (lower)	R/W	0b00000000
0x0070	WCSR	Watch counter status register	R/W	0b00000000
0x0071	FSR2	Flash memory status register 2	R/W	0b00000000
0x0072	FSR	Flash memory status register	R/W	0b000X0000
0x0073	SWRE0	Flash memory sector write control register 0	R/W	0b00000000
0x0074	FSR3	Flash memory status register 3	R	0b000XXXXX
0x0075	FSR4	Flash memory status register 4	R/W	0b00000000
0x0076	WREN	Wild register address compare enable register	R/W	0b00000000
0x0077	WROR	Wild register data test setting register	R/W	0b00000000
0x0078	—	Mirror of register bank pointer (RP) and direct bank pointer (DP)	—	—
0x0079	ILR0	Interrupt level setting register 0	R/W	0b11111111
0x007A	ILR1	Interrupt level setting register 1	R/W	0b11111111
0x007B	ILR2	Interrupt level setting register 2	R/W	0b11111111
0x007C	ILR3	Interrupt level setting register 3	R/W	0b11111111
0x007D	ILR4	Interrupt level setting register 4	R/W	0b11111111
0x007E	ILR5	Interrupt level setting register 5	R/W	0b11111111
0x007F	—	(Disabled)	—	—
0x0F80	WRARH0	Wild register address setting register (upper) ch. 0	R/W	0b00000000
0x0F81	WRARL0	Wild register address setting register (lower) ch. 0	R/W	0b00000000
0x0F82	WRDR0	Wild register data setting register ch. 0	R/W	0b00000000
0x0F83	WRARH1	Wild register address setting register (upper) ch. 1	R/W	0b00000000
0x0F84	WRARL1	Wild register address setting register (lower) ch. 1	R/W	0b00000000
0x0F85	WRDR1	Wild register data setting register ch. 1	R/W	0b00000000
0x0F86	WRARH2	Wild register address setting register (upper) ch. 2	R/W	0b00000000
0x0F87	WRARL2	Wild register address setting register (lower) ch. 2	R/W	0b00000000
0x0F88	WRDR2	Wild register data setting register ch. 2	R/W	0b00000000
0x0F89 to 0x0F91	—	(Disabled)	—	—
0x0F92	T01CR0	8/16-bit composite timer 01 status control register 0	R/W	0b00000000
0x0F93	T00CR0	8/16-bit composite timer 00 status control register 0	R/W	0b00000000

(Continued)

Address	Register abbreviation	Register name	R/W	Initial value
0x0F94	T01DR	8/16-bit composite timer 01 data register	R/W	0b00000000
0x0F95	T00DR	8/16-bit composite timer 00 data register	R/W	0b00000000
0x0F96	TMCR0	8/16-bit composite timer 00/01 timer mode control register	R/W	0b00000000
0x0F97	T11CR0	8/16-bit composite timer 11 status control register 0	R/W	0b00000000
0x0F98	T10CR0	8/16-bit composite timer 10 status control register 0	R/W	0b00000000
0x0F99	T11DR	8/16-bit composite timer 11 data register	R/W	0b00000000
0x0F9A	T10DR	8/16-bit composite timer 10 data register	R/W	0b00000000
0x0F9B	TMCR1	8/16-bit composite timer 10/11 timer mode control register	R/W	0b00000000
0x0F9C	PPS01	8/16-bit PPG01 cycle setting buffer register	R/W	0b11111111
0x0F9D	PPS00	8/16-bit PPG00 cycle setting buffer register	R/W	0b11111111
0x0F9E	PDS01	8/16-bit PPG01 duty setting buffer register	R/W	0b11111111
0x0F9F	PDS00	8/16-bit PPG00 duty setting buffer register	R/W	0b11111111
0x0FA0	PPS11	8/16-bit PPG11 cycle setting buffer register	R/W	0b11111111
0x0FA1	PPS10	8/16-bit PPG10 cycle setting buffer register	R/W	0b11111111
0x0FA2	PDS11	8/16-bit PPG11 duty setting buffer register	R/W	0b11111111
0x0FA3	PDS10	8/16-bit PPG10 duty setting buffer register	R/W	0b11111111
0x0FA4	PPGS	8/16-bit PPG start register	R/W	0b00000000
0x0FA5	REVC	8/16-bit PPG output inversion register	R/W	0b00000000
0x0FA6	TMRH0	16-bit reload timer timer register (upper) ch. 0	R/W	0b00000000
	TMRLRH0	16-bit reload timer reload register (upper) ch. 0		
0x0FA7	TMRL0	16-bit reload timer timer register (lower) ch. 0	R/W	0b00000000
	TMRLRL0	16-bit reload timer reload register (lower) ch. 0		
0x0FA8	PSSR0	UART/SIO dedicated baud rate generator prescaler select register ch. 0	R/W	0b00000000
0x0FA9	BRSR0	UART/SIO dedicated baud rate generator baud rate setting register ch. 0	R/W	0b00000000
0x0FAA	PSSR1	UART/SIO dedicated baud rate generator prescaler select register ch. 1	R/W	0b00000000
0x0FAB	BRSR1	UART/SIO dedicated baud rate generator baud rate setting register ch. 1	R/W	0b00000000
0x0FAC to 0x0FAE	—	(Disabled)	—	—
0x0FAF	AIDRL	A/D input disable register (lower)	R/W	0b00000000
0x0FB0	LCDCC1	LCDC control register 1	R/W	0b00000000
0x0FB1	—	(Disabled)	—	—
0x0FB2	LCDCE1	LCDC enable register 1	R/W	0b00111110
0x0FB3	LCDCE2	LCDC enable register 2	R/W	0b00000000
0x0FB4	LCDCE3	LCDC enable register 3	R/W	0b00000000
0x0FB5	LCDCE4	LCDC enable register 4	R/W	0b00000000
0x0FB6	LCDCE5	LCDC enable register 5	R/W	0b00000000

(Continued)

(Continued)

Address	Register abbreviation	Register name	R/W	Initial value
0x0FB7	LCDCE6	LCDC enable register 6	R/W	0b00000000
0x0FB8	LCDCE7	LCDC enable register 7	R/W	0b00000000
0x0FB9	LCDCE8	LCDC enable register 8	R/W	0b00000000
0x0FBA	LCDCE9	LCDC enable register 9	R/W	0b00000000
0x0FBB	LCDCB1	LCDC blinking setting register 1	R/W	0b00000000
0x0FBC	LCDCB2	LCDC blinking setting register 2	R/W	0b00000000
0x0FBD to 0x0FE0	LCDRAM	LCDC display RAM 4 COM mode: 0x0FBD to 0x0FD6 (26 bytes) 8 COM mode: 0x0FC1 to 0x0FE0 (32 bytes)	R/W	0b00000000
0x0FE1	—	(Disabled)	—	—
0x0FE2	EVCR	Event counter control register	R/W	0bXXXXXXXX0
0x0FE3	WCDR	Watch counter data register	R/W	0b00111111
0x0FE4	CRTH	Main CR clock trimming register (upper)	R/W	0b000XXXXX
0x0FE5	CRTL	Main CR clock trimming register (lower)	R/W	0b000XXXXX
0x0FE6	—	(Disabled)	—	—
0x0FE7	CRTDA	Main CR clock temperature dependent adjustment register	R/W	0b000XXXXX
0x0FE8	SYSC	System configuration register	R/W	0b11000011
0x0FE9	CMCR	Clock monitoring control register	R/W	0b00000000
0x0FEA	CMDR	Clock monitoring data register	R	0b00000000
0x0FEB	WDTH	Watchdog timer selection ID register (upper)	R	0bXXXXXXXXXX
0x0FEC	WDTL	Watchdog timer selection ID register (lower)	R	0bXXXXXXXXXX
0x0FED, 0x0FEE	—	(Disabled)	—	—
0x0FEF	WICR	Interrupt pin selection circuit control register	R/W	0b01000000
0x0FF0 to 0x0FFF	LCDRAM	LCDC display RAM 4 COM mode: Unused 8 COM mode: 0x0FF0 to 0x0FFF (16 bytes)	R/W	0b00000000

- R/W access symbols
R/W : Readable/Writable
R : Read only
- Initial value symbols
0 : The initial value of this bit is “0”.
1 : The initial value of this bit is “1”.
X : The initial value of this bit is undefined.

Note: Do not write to an address that is “(Disabled)”. If a “(Disabled)” address is read, an indeterminate value is returned.

■ I/O PORTS

- List of port registers

Register name		Read/Write	Initial value
Port 0 data register	PDR0	R, RM/W	0b00000000
Port 0 direction register	DDR0	R/W	0b00000000
Port 1 data register	PDR1	R, RM/W	0b00000000
Port 1 direction register	DDR1	R/W	0b00000000
Port 2 data register	PDR2	R, RM/W	0b00000000
Port 2 direction register	DDR2	R/W	0b00000000
Port 3 data register	PDR3	R, RM/W	0b00000000
Port 3 direction register	DDR3	R/W	0b00000000
Port 5 data register	PDR5	R, RM/W	0b00000000
Port 5 direction register	DDR5	R/W	0b00000000
Port 9 data register	PDR9	R, RM/W	0b00000000
Port 9 direction register	DDR9	R/W	0b00000000
Port F data register	PDRF	R, RM/W	0b00000000
Port F direction register	DDRF	R/W	0b00000000
Port G data register	PDRG	R, RM/W	0b00000000
Port G direction register	DDRG	R/W	0b00000000
Port 1 pull-up register	PUL1	R/W	0b00000000
Port 5 pull-up register	PUL5	R/W	0b00000000
Port G pull-up register	PULG	R/W	0b00000000
A/D input disable register (lower)	AIDRL	R/W	0b00000000

R/W : Readable/writable (The read value is the same as the write value.)

R, RM/W : Readable/writable (The read value is different from the write value. The write value is read by the read-modify-write (RMW) type of instruction.)

1. Port 0

Port 0 is a general-purpose I/O port. This section focuses on its functions as a general-purpose I/O port. For details of peripheral functions, refer to their respective chapters in the hardware manual of the MB95610H Series.

(1) Port 0 configuration

Port 0 is made up of the following elements.

- General-purpose I/O pins/peripheral function I/O pins
- Port 0 data register (PDR0)
- Port 0 direction register (DDR0)
- A/D input disable register (lower) (AIDRL)

(2) Block diagrams of port 0

- P00/INT00/AN00 pin
 - This pin has the following peripheral functions:
 - External interrupt circuit input pin (INT00)
 - 8/10-bit A/D converter analog input pin (AN00)
- P01/INT01/AN01 pin
 - This pin has the following peripheral functions:
 - External interrupt circuit input pin (INT01)
 - 8/10-bit A/D converter analog input pin (AN01)
- P02/INT02/AN02 pin
 - This pin has the following peripheral functions:
 - External interrupt circuit input pin (INT02)
 - 8/10-bit A/D converter analog input pin (AN02)
- P03/INT03/AN03 pin
 - This pin has the following peripheral functions:
 - External interrupt circuit input pin (INT03)
 - 8/10-bit A/D converter analog input pin (AN03)
- Block diagram of P00/INT00/AN00, P01/INT01/AN01, P02/INT02/AN02 and P03/INT03/AN03

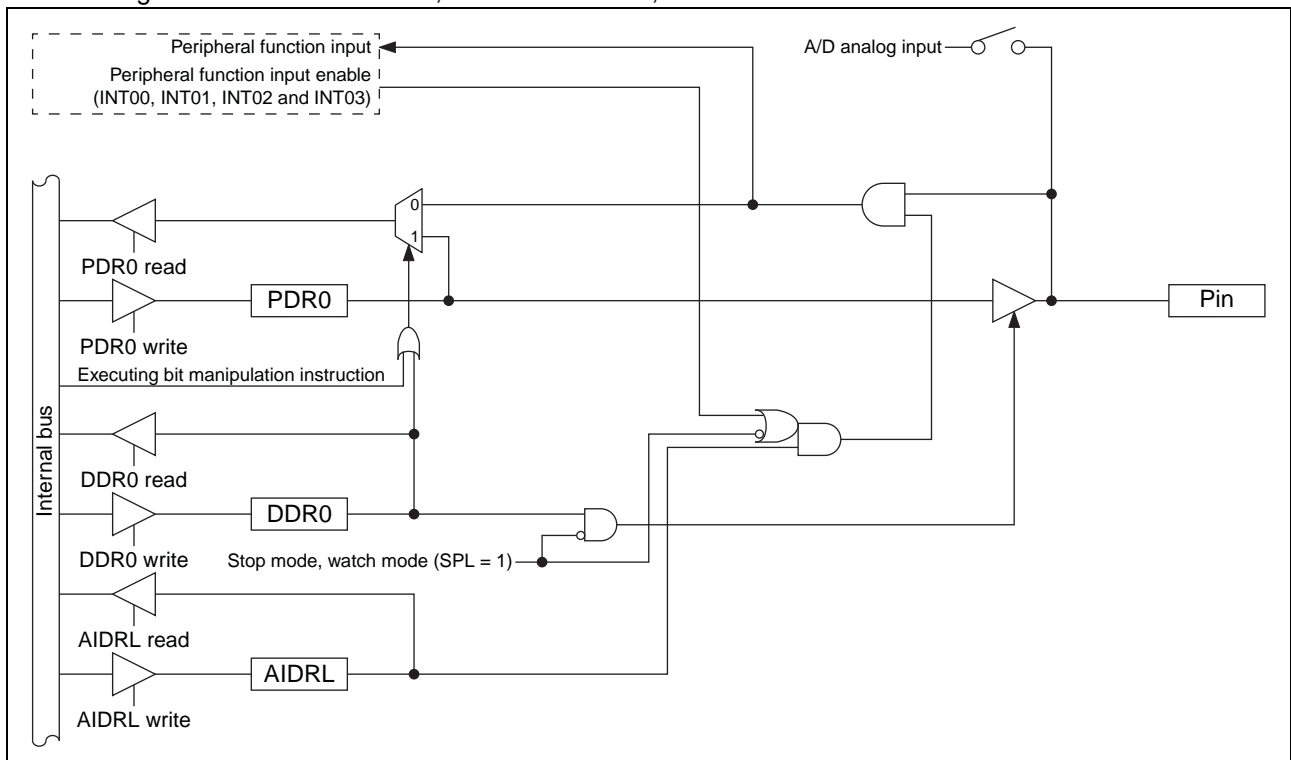

(Continued)

- P04/SEG32 pin
 - This pin has the following peripheral function:
 - LCDC SEG32 output pin (SEG32)

• Block diagram of P04/SEG32

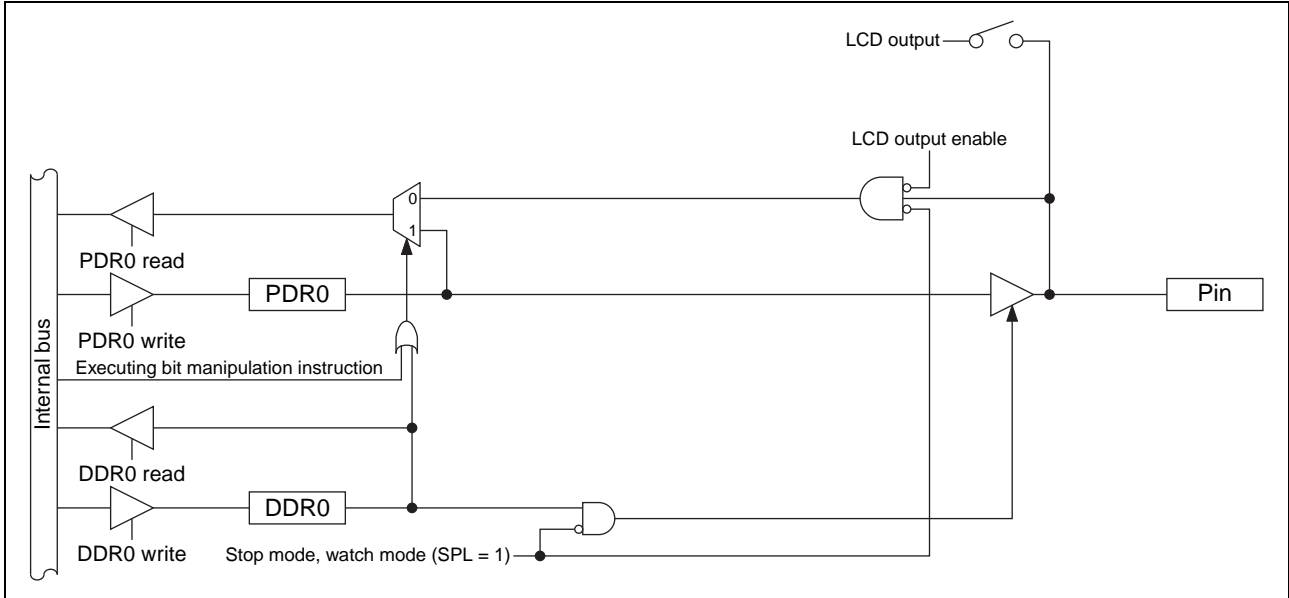

- P05/SEG33/ADTG pin
 - This pin has the following peripheral functions:
 - LCDC SEG33 output pin (SEG33)
 - 8/10-bit A/D converter trigger input pin (ADTG)

• Block diagram of P05/SEG33/ADTG

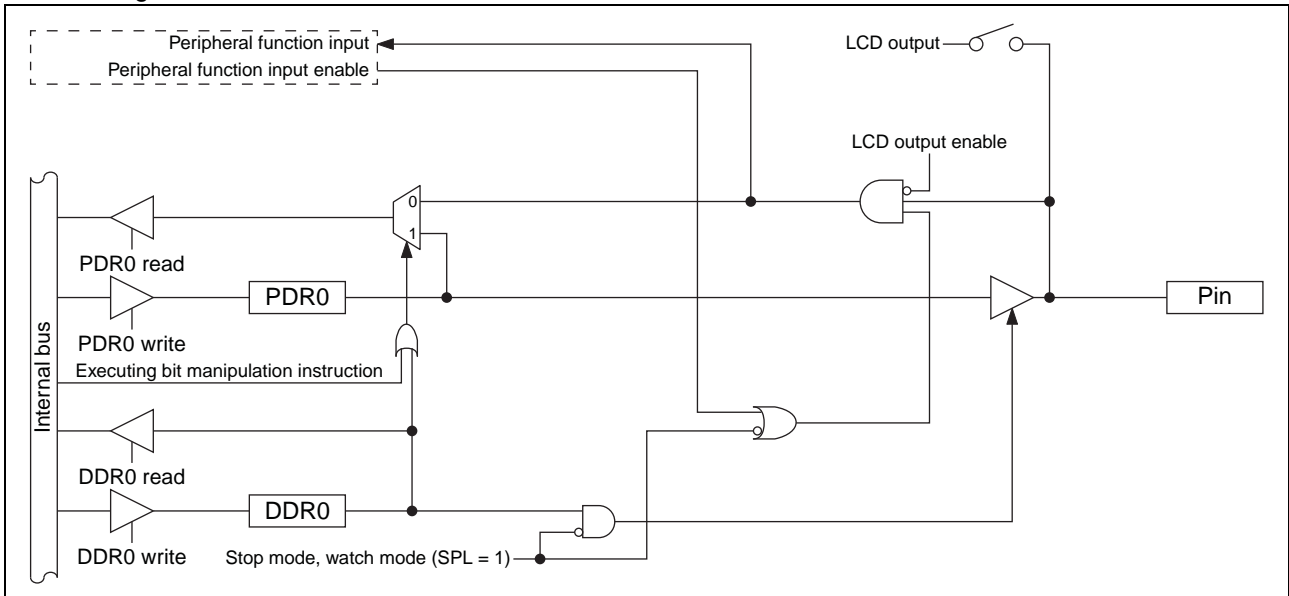

(Continued)

(Continued)

- P06/SEG34/PPG10 pin
 - This pin has the following peripheral functions:
 - LCD SEG34 output pin (SEG34)
 - 8/16-bit PPG ch. 1 output pin (PPG10)
- P07/SEG35/PPG11 pin
 - This pin has the following peripheral functions:
 - LCD SEG35 output pin (SEG35)
 - 8/16-bit PPG ch. 1 output pin (PPG11)

- Block diagram of P06/SEG34/PPG10 and P07/SEG35/PPG11

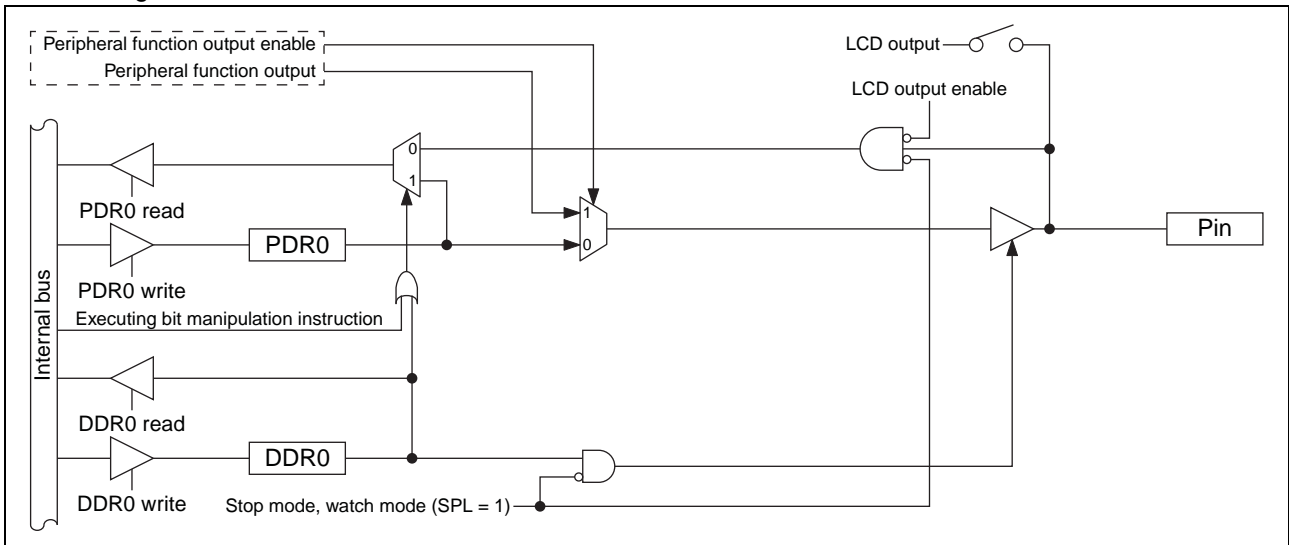

(3) Port 0 registers

- Port 0 register functions

Register abbreviation	Data	Read	Read by read-modify-write (RMW) instruction	Write
PDR0	0	Pin state is "L" level.	PDR0 value is "0".	As output port, outputs "L" level.
	1	Pin state is "H" level.	PDR0 value is "1".	As output port, outputs "H" level.
DDR0	0	Port input enabled		
	1	Port output enabled		
AIDRL	0	Analog input enabled		
	1	Port input enabled		

- Correspondence between registers and pins for port 0

Pin name	Correspondence between related register bits and pins							
	P07	P06	P05	P04	P03	P02	P01	P00
PDR0	bit7	bit6	bit5	bit4	bit3	bit2	bit1	bit0
DDR0								
AIDRL	-	-	-	-				

(4) Port 0 operations

- Operation as an output port
 - A pin becomes an output port if the bit in the DDR0 register corresponding to that pin is set to “1”.
 - For a pin shared with other peripheral functions, disable the output of such peripheral functions.
 - When a pin is used as an output port, it outputs the value of the PDR0 register to external pins.
 - If data is written to the PDR0 register, the value is stored in the output latch and is output to the pin set as an output port as it is.
 - Reading the PDR0 register returns the PDR0 register value.
 - To use a pin shared with the LCDC as an output port, set a corresponding function select bit (SEG[35:32]) in the LCDC enable register 7 (LCDCE7) to “0” to select the general-purpose I/O port function, and then set the port input control bit (PICTL) in the LCDC enable register 1 (LCDCE1) to “1”.

- Operation as an input port
 - A pin becomes an input port if the bit in the DDR0 register corresponding to that pin is set to “0”.
 - For a pin shared with other peripheral functions, disable the output of such peripheral functions.
 - When using an analog input shared pin as an input port, set the corresponding bit in the A/D input disable register (lower) (AIDRL) to “1”.
 - If data is written to the PDR0 register, the value is stored in the output latch but is not output to the pin set as an input port.
 - Reading the PDR0 register returns the pin value. However, if the read-modify-write (RMW) type of instruction is used to read the PDR0 register, the PDR0 register value is returned.
 - To use a pin shared with the LCDC as an input port, set a corresponding function select bit (SEG[35:32]) in the LCDCE7 register to “0” to select the general-purpose I/O port function, and then set the PICTL bit in the LCDCE1 register to “1”.

- Operation as a peripheral function output pin
 - A pin becomes a peripheral function output pin if the peripheral output function is enabled by setting the output enable bit of a peripheral function corresponding to that pin.
 - The pin value can be read from the PDR0 register even if the peripheral function output is enabled. Therefore, the output value of a peripheral function can be read by the read operation on the PDR0 register. However, if the read-modify-write (RMW) type of instruction is used to read the PDR0 register, the PDR0 register value is returned.

- Operation as a peripheral function input pin
 - To set a pin as an input port, set the bit in the DDR0 register corresponding to the input pin of a peripheral function to “0”.
 - When using the analog input shared pin as another peripheral function input pin, configure it as an input port, which is the same as the operation as an input port.
 - Reading the PDR0 register returns the pin value, regardless of whether the peripheral function uses that pin as its input pin. However, if the read-modify-write (RMW) type of instruction is used to read the PDR0 register, the PDR0 register value is returned.

- Operation as an LCDC segment output pin
 - Set the bit in the DDR0 register corresponding to a desired LCDC segment output pin to “0”.
 - Select the segment pin by setting a corresponding function select bit (SEG[35:32]) in the LCDCE7 register to “1”, and then set the PICTL bit in the LCDCE1 register to “1”.

- Operation at reset

If the CPU is reset, all bits in the DDR0 register are initialized to “0” and port input is enabled. As for a pin shared with analog input, its port input is disabled because the AIDRL register is initialized to “0”.

(Continued)

(Continued)

- Operation in stop mode and watch mode
 - If the pin state setting bit in the standby control register (STBC:SPL) is set to “1” and the device transits to stop mode or watch mode, the pin is compulsorily made to enter the high impedance state regardless of the DDR0 register value. The input of that pin is locked to “L” level and blocked in order to prevent leaks due to input open. However, if the interrupt input is enabled for the external interrupt (INT00 to INT03), the input is enabled and not blocked.
 - If the pin state setting bit is “0”, the state of the port I/O or that of the peripheral function I/O remains unchanged and the output level is maintained.
- Operation as an analog input pin
 - Set the bit in the DDR0 register bit corresponding to the analog input pin to “0” and the bit corresponding to that pin in the AIDRL register to “0”.
 - For a pin shared with other peripheral functions, disable the output of such peripheral functions.
- Operation as an external interrupt input pin
 - Set the bit in the DDR0 register corresponding to the external interrupt input pin to “0”.
 - For a pin shared with other peripheral functions, disable the output of such peripheral functions.
 - The pin value is always input to the external interrupt circuit. When using a pin for a function other than the interrupt, disable the external interrupt function corresponding to that pin.

2. Port 1

Port 1 is a general-purpose I/O port. This section focuses on its functions as a general-purpose I/O port. For details of peripheral functions, refer to their respective chapters in the hardware manual of the MB95610H Series.

(1) Port 1 configuration

Port 1 is made up of the following elements.

- General-purpose I/O pins/peripheral function I/O pins
- Port 1 data register (PDR1)
- Port 1 direction register (DDR1)
- Port 1 pull-up register (PUL1)

(2) Block diagrams of port 1

- P12/DBG pin

This pin has the following peripheral function:

- DBG input pin (DBG)

- Block diagram of P12/DBG

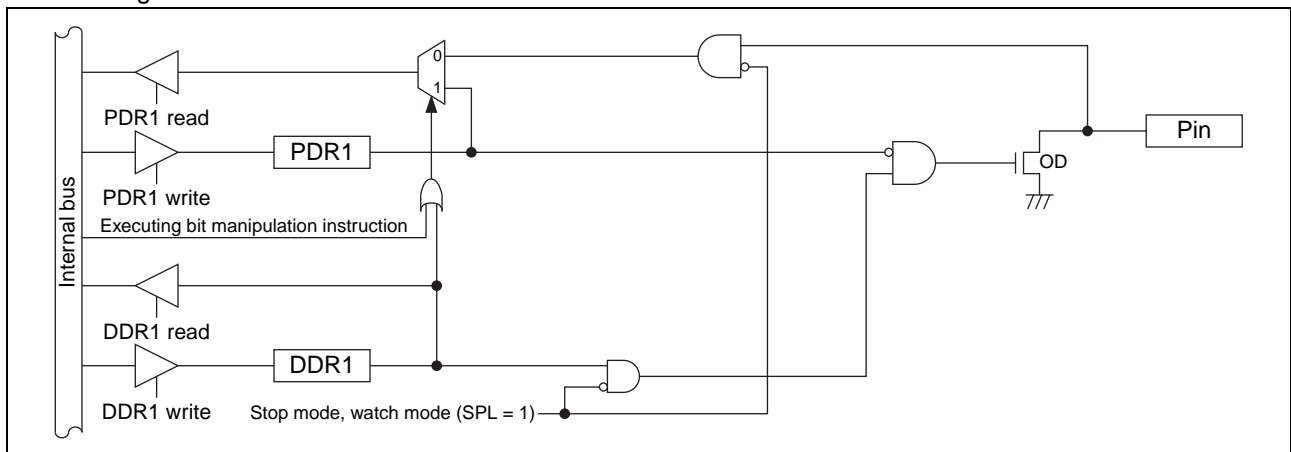

(Continued)

- P13/UO0 pin
 - This pin has the following peripheral function:
 - UART/SIO ch. 0 data output pin (UO0)

• Block diagram of P13/UO0

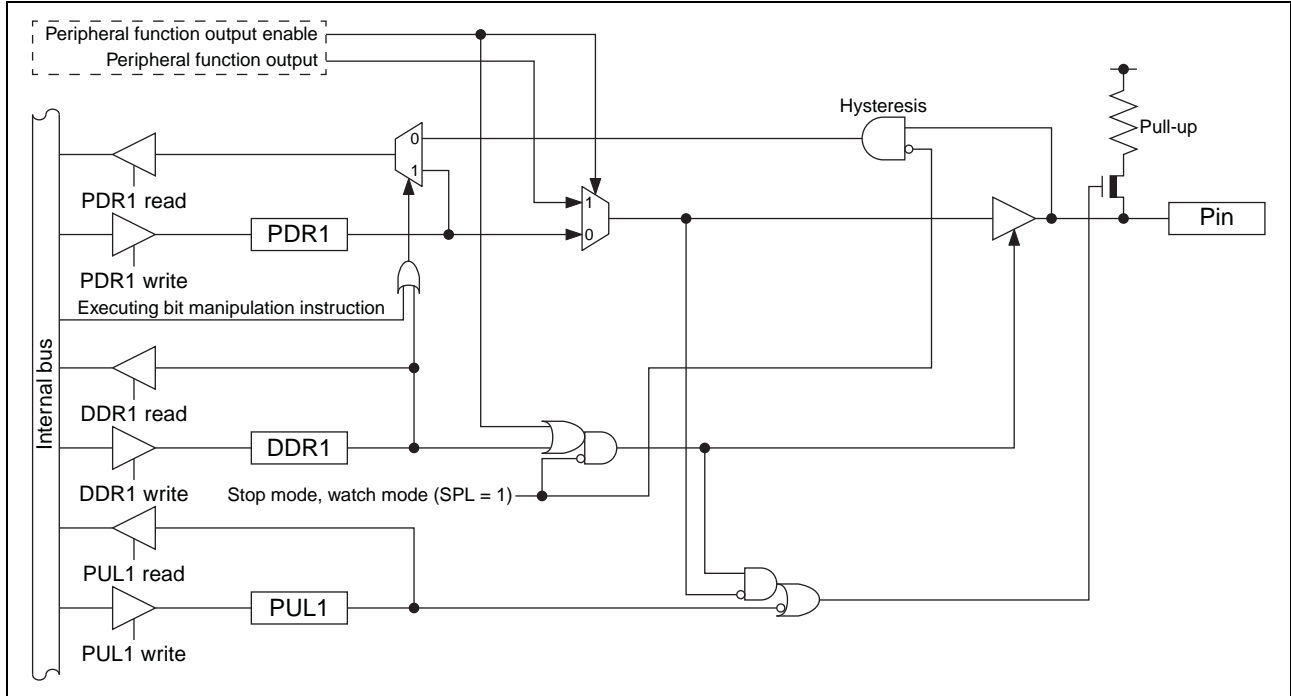

- P14/UCK0 pin
 - This pin has the following peripheral function:
 - UART/SIO ch. 0 clock I/O pin (UCK0)

• Block diagram of P14/UCK0

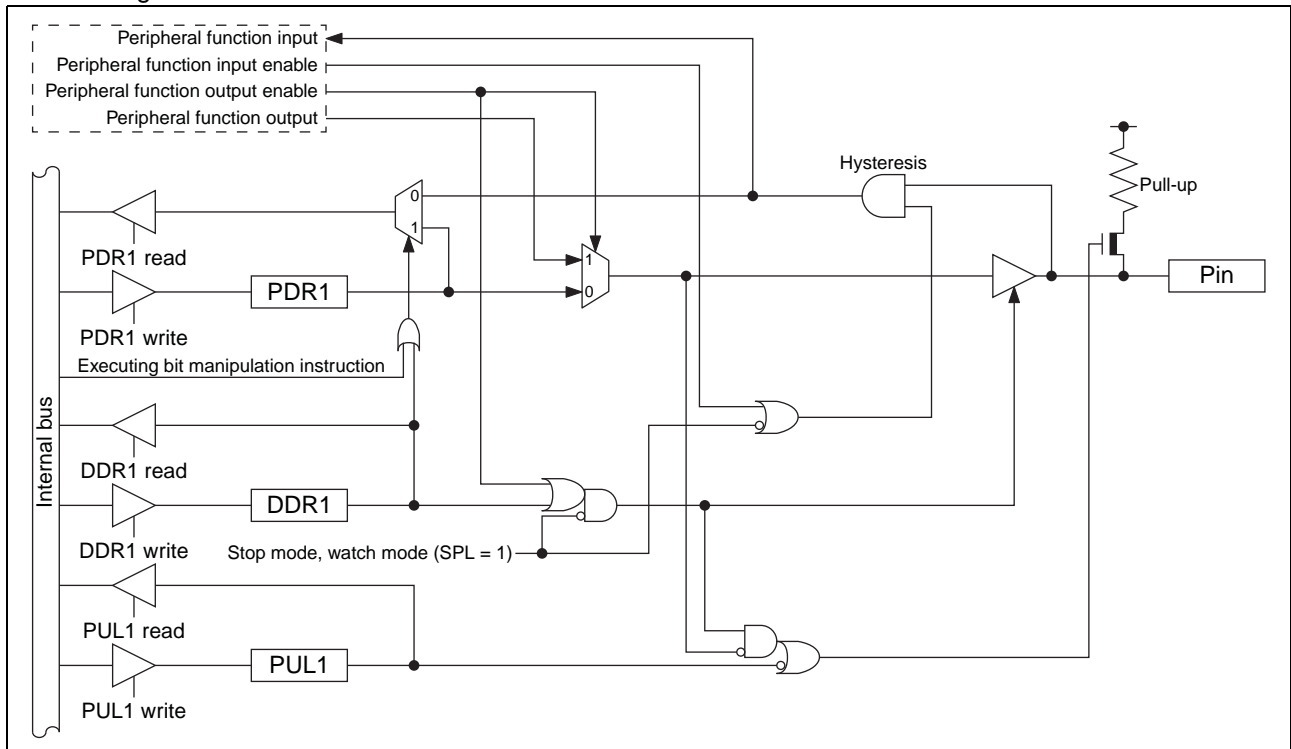

(Continued)

(Continued)

- P15/UI0 pin
 - This pin has the following peripheral function:
 - UART/SIO ch. 0 data input pin (UI0)

• Block diagram of P15/UI0

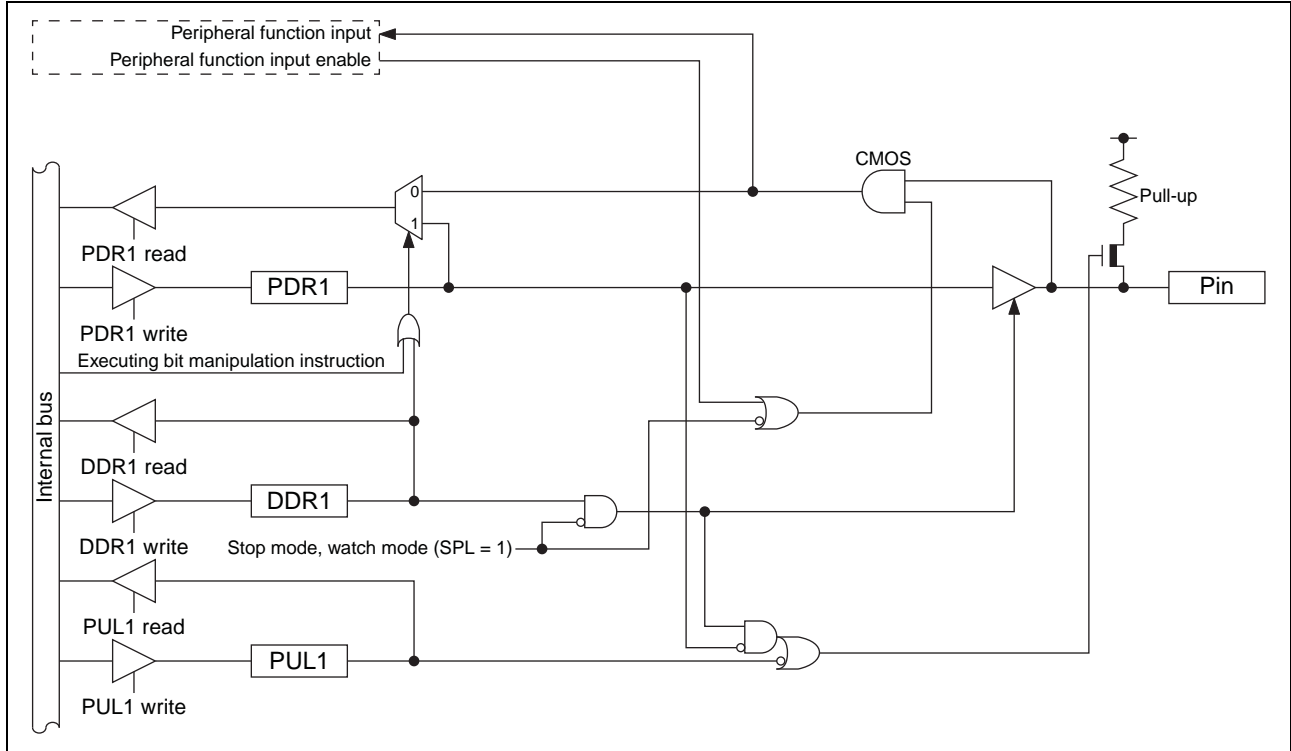

(3) Port 1 registers

- Port 1 register functions

Register abbreviation	Data	Read	Read by read-modify-write (RMW) instruction	Write
PDR1	0	Pin state is "L" level.	PDR1 value is "0".	As output port, outputs "L" level.
	1	Pin state is "H" level.	PDR1 value is "1".	As output port, outputs "H" level.*
DDR1	0	Port input enabled		
	1	Port output enabled		
PUL1	0	Pull-up disabled		
	1	Pull-up enabled		

*: If the pin is an N-ch open drain pin, the pin state becomes Hi-Z.

- Correspondence between registers and pins for port 1

Pin name	Correspondence between related register bits and pins							
	-	-	P15	P14	P13	P12	-	-
PDR1			bit5	bit4	bit3	bit2*		
DDR1	-	-	bit5	bit4	bit3	bit2*	-	-
PUL1								

*: Though P12 has no pull-up function, bit2 in the PUL1 register can still be accessed. The operation of P12 is not affected by the setting of bit2 in the PUL1 register.

(4) Port 1 operations

- Operation as an output port
 - A pin becomes an output port if the bit in the DDR1 register corresponding to that pin is set to “1”.
 - For a pin shared with other peripheral functions, disable the output of such peripheral functions.
 - When a pin is used as an output port, it outputs the value of the PDR1 register to external pins.
 - If data is written to the PDR1 register, the value is stored in the output latch and is output to the pin set as an output port as it is.
 - Reading the PDR1 register returns the PDR1 register value.
- Operation as an input port
 - A pin becomes an input port if the bit in the DDR1 register corresponding to that pin is set to “0”.
 - For a pin shared with other peripheral functions, disable the output of such peripheral functions.
 - If data is written to the PDR1 register, the value is stored in the output latch but is not output to the pin set as an input port.
 - Reading the PDR1 register returns the pin value. However, if the read-modify-write (RMW) type of instruction is used to read the PDR1 register, the PDR1 register value is returned.
- Operation as a peripheral function output pin
 - A pin becomes a peripheral function output pin if the peripheral output function is enabled by setting the output enable bit of a peripheral function corresponding to that pin.
 - The pin value can be read from the PDR1 register even if the peripheral function output is enabled. Therefore, the output value of a peripheral function can be read by the read operation on the PDR1 register. However, if the read-modify-write (RMW) type of instruction is used to read the PDR1 register, the PDR1 register value is returned.
- Operation as a peripheral function input pin
 - To set a pin as an input port, set the bit in the DDR1 register corresponding to the input pin of a peripheral function to “0”.
 - Reading the PDR1 register returns the pin value, regardless of whether the peripheral function uses that pin as its input pin. However, if the read-modify-write (RMW) type of instruction is used to read the PDR1 register, the PDR1 register value is returned.
- Operation at reset

If the CPU is reset, all bits in the DDR1 register are initialized to “0” and port input is enabled.
- Operation in stop mode and watch mode
 - If the pin state setting bit in the standby control register (STBC:SPL) is set to “1” and the device transits to stop mode or watch mode, the pin is compulsorily made to enter the high impedance state regardless of the DDR1 register value. The input of that pin is locked to “L” level and blocked in order to prevent leaks due to input open. However, if the interrupt input of P14/UICK0 and P15/UI0 is enabled by the external interrupt control register ch. 0 (EIC00) of the external interrupt circuit and the interrupt pin selection circuit control register (WICR) of the interrupt pin selection circuit, the input is enabled and is not blocked.
 - If the pin state setting bit is “0”, the state of the port I/O or that of the peripheral function I/O remains unchanged and the output level is maintained.
- Operation of the pull-up register

Setting the bit in the PUL1 register to “1” makes the pull-up resistor be internally connected to the pin. When the pin output is “L” level, the pull-up resistor is disconnected regardless of the value of the PUL1 register.

3. Port 2

Port 2 is a general-purpose I/O port. This section focuses on its functions as a general-purpose I/O port. For details of peripheral functions, refer to their respective chapters in the hardware manual of the MB95610H Series.

(1) Port 2 configuration

Port 2 is made up of the following elements.

- General-purpose I/O pins/peripheral function I/O pins
- Port 2 data register (PDR2)
- Port 2 direction register (DDR2)

(2) Block diagrams of port 2

• P20/SEG44/TI0 pin

This pin has the following peripheral functions:

- LCD SEG44 output pin (SEG44)
- 16-bit reload timer ch. 0 input pin (TI0)

• P23/SEG47/UI1 pin

This pin has the following peripheral functions:

- LCD SEG47 output pin (SEG47)
- UART/SIO ch. 1 data input pin (UI1)

• Block diagram of P20/SEG44/TI0 and P23/SEG47/UI1

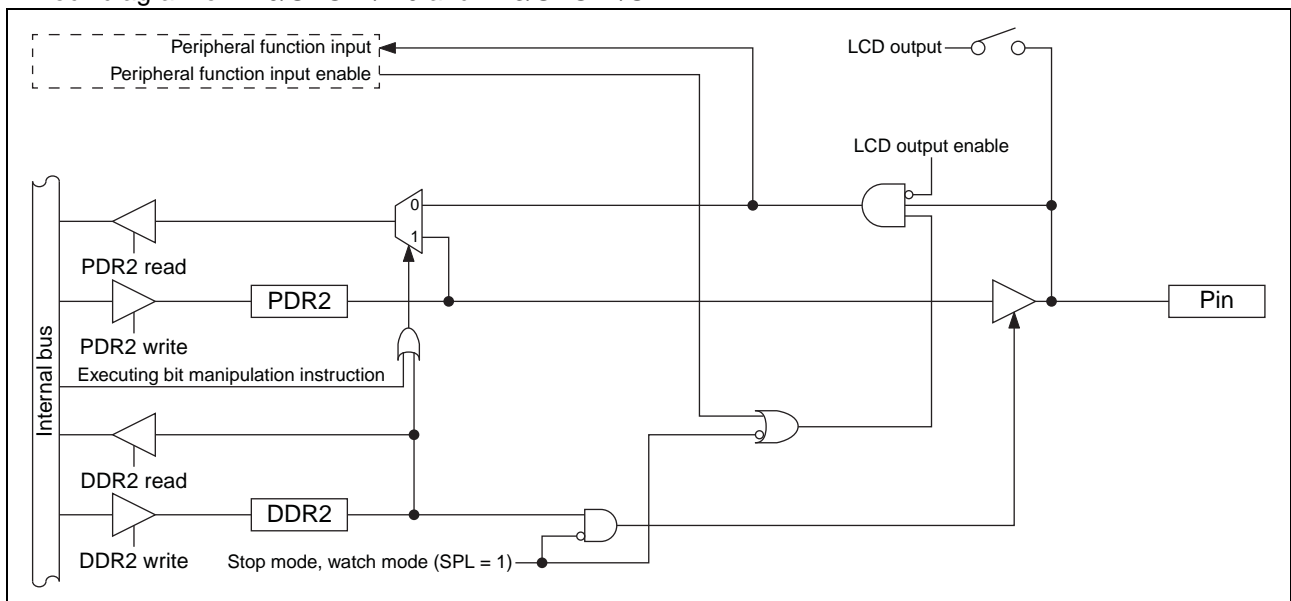

(Continued)

- P21/SEG45/UO1 pin
 - This pin has the following peripheral functions:
 - LCD SEG45 output pin (SEG45)
 - UART/SIO ch. 1 data output pin (UO1)
- P24/SEG48/PPG00 pin
 - This pin has the following peripheral functions:
 - LCD SEG48 output pin (SEG48)
 - 8/16-bit PPG ch. 0 output pin (PPG00)
- P25/SEG49/PPG01 pin
 - This pin has the following peripheral functions:
 - LCD SEG49 output pin (SEG49)
 - 8/16-bit PPG ch. 0 output pin (PPG01)

• Block diagram of P21/SEG45/UO1, P24/SEG48/PPG00 and P25/SEG49/PPG01

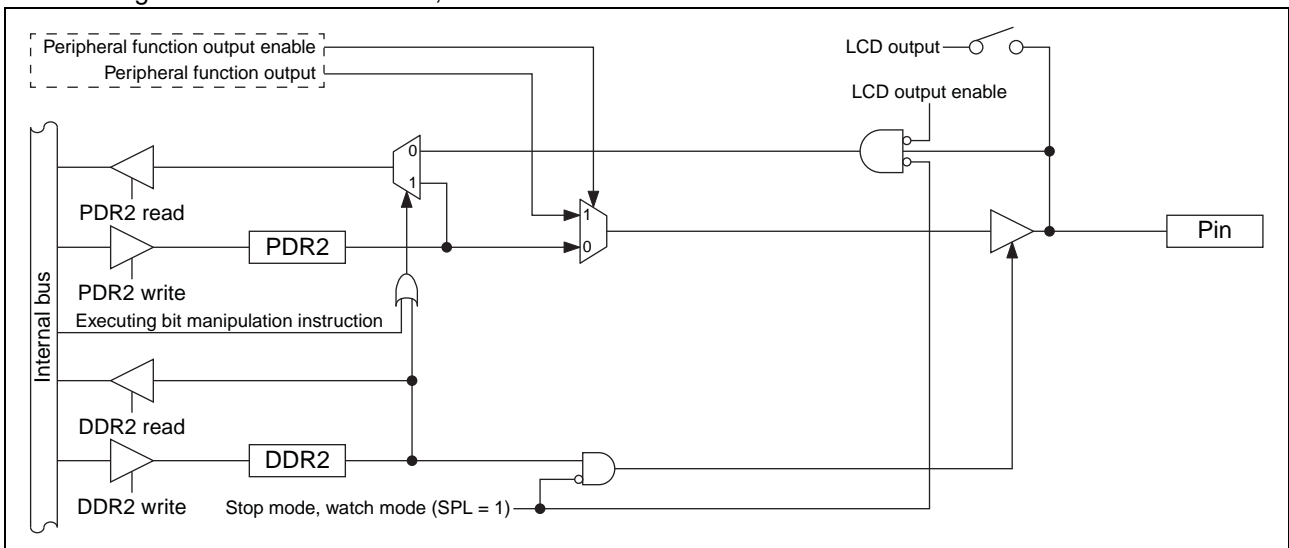

(Continued)

(Continued)

- P22/SEG46/UCK1 pin
 - This pin has the following peripheral functions:
 - LCD SEG46 output pin (SEG46)
 - UART/SIO ch. 1 clock I/O pin (UCK1)

- P26/SEG50/SCL pin
 - This pin has the following peripheral functions:
 - LCD SEG50 output pin (SEG50)
 - I²C bus interface ch. 0 clock I/O pin (SCL)

- P27/SEG51/SDA pin
 - This pin has the following peripheral functions:
 - LCD SEG51 output pin (SEG51)
 - I²C bus interface ch. 0 data I/O pin (SDA)

- Block diagram of P22/SEG46/UCK1, P26/SEG50/SCL and P27/SEG51/SDA

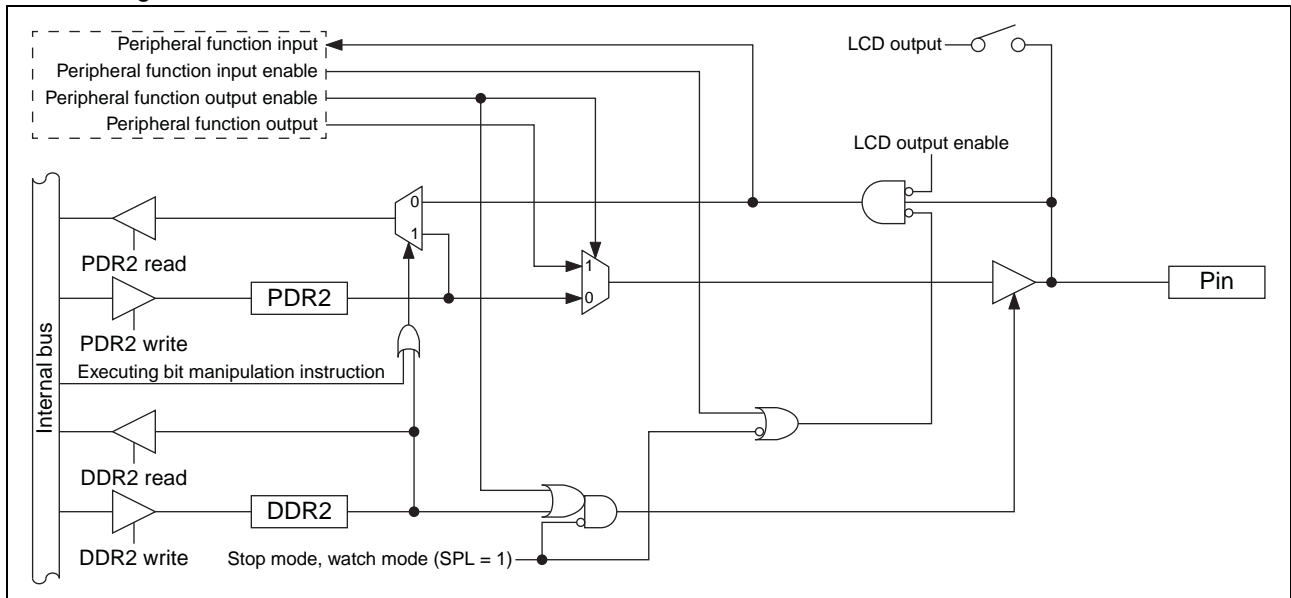

(3) Port 2 registers

- Port 2 register functions

Register abbreviation	Data	Read	Read by read-modify-write (RMW) instruction	Write
PDR2	0	Pin state is "L" level.	PDR2 value is "0".	As output port, outputs "L" level.
	1	Pin state is "H" level.	PDR2 value is "1".	As output port, outputs "H" level.
DDR2	0	Port input enabled		
	1	Port output enabled		

- Correspondence between registers and pins for port 2

Pin name	Correspondence between related register bits and pins							
	P27	P26	P25	P24	P23	P22	P21	P20
PDR2	bit7	bit6	bit5	bit4	bit3	bit2	bit1	bit0
DDR2								

(4) Port 2 operations

- Operation as an output port
 - A pin becomes an output port if the bit in the DDR2 register corresponding to that pin is set to “1”.
 - For a pin shared with other peripheral functions, disable the output of such peripheral functions.
 - When a pin is used as an output port, it outputs the value of the PDR2 register to external pins.
 - If data is written to the PDR2 register, the value is stored in the output latch and is output to the pin set as an output port as it is.
 - Reading the PDR2 register returns the PDR2 register value.
 - To use a pin shared with the LCDC as an output port, set a corresponding function select bit in the LCDC enable register 9 (LCDCE9:SEG[51:48]) or in the LCDC enable register 8 (LCDCE8:SEG[47:44]) to “0” to select the general-purpose I/O port function, and then set the port input control bit (PICTL) in the LCDC enable register 1 (LCDCE1) to “1”.

- Operation as an input port
 - A pin becomes an input port if the bit in the DDR2 register corresponding to that pin is set to “0”.
 - For a pin shared with other peripheral functions, disable the output of such peripheral functions.
 - If data is written to the PDR2 register, the value is stored in the output latch but is not output to the pin set as an input port.
 - Reading the PDR2 register returns the pin value. However, if the read-modify-write (RMW) type of instruction is used to read the PDR2 register, the PDR2 register value is returned.
 - To use a pin shared with the LCDC as an input port, set a corresponding function select bit in the LCDC enable register 9 (LCDCE9:SEG[51:48]) or in the LCDC enable register 8 (LCDCE8:SEG[47:44]) to “0” to select the general-purpose I/O port function, and then set the port input control bit (PICTL) in the LCDC enable register 1 (LCDCE1) to “1”.

- Operation as a peripheral function output pin
 - A pin becomes a peripheral function output pin if the peripheral output function is enabled by setting the output enable bit of a peripheral function corresponding to that pin.
 - The pin value can be read from the PDR2 register even if the peripheral function output is enabled. Therefore, the output value of a peripheral function can be read by the read operation on the PDR2 register. However, if the read-modify-write (RMW) type of instruction is used to read the PDR2 register, the PDR2 register value is returned.

- Operation as a peripheral function input pin
 - To set a pin as an input port, set the bit in the DDR2 register corresponding to the input pin of a peripheral function to “0”.
 - Reading the PDR2 register returns the pin value, regardless of whether the peripheral function uses that pin as its input pin. However, if the read-modify-write (RMW) type of instruction is used to read the PDR2 register, the PDR2 register value is returned.

- Operation as an LCDC segment output pin
 - Set the bit in the DDR2 register corresponding to a desired LCDC segment output pin to “0”.
 - Select the segment pin by setting a corresponding function select bit in the LCDC enable register 9 (LCDCE9:SEG[51:48]) or in the LCDC enable register 8 (LCDCE8:SEG[47:44]) to “1”, and then set the PICTL bit in the LCDCE1 register to “1”.

- Operation at reset

If the CPU is reset, all bits in the DDR2 register are initialized to “0” and port input is enabled.

- Operation in stop mode and watch mode
 - If the pin state setting bit in the standby control register (STBC:SPL) is set to “1” and the device transits to stop mode or watch mode, the pin is compulsorily made to enter the high impedance state regardless of the DDR2 register value. The input of that pin is locked to “L” level and blocked in order to prevent leaks due to input open.
 - If the pin state setting bit is “0”, the state of the port I/O or that of the peripheral function I/O remains unchanged and the output level is maintained.

4. Port 3

Port 3 is a general-purpose I/O port. This section focuses on its functions as a general-purpose I/O port. For details of peripheral functions, refer to their respective chapters in the hardware manual of the MB95610H Series.

(1) Port 3 configuration

Port 3 is made up of the following elements.

- General-purpose I/O pins/peripheral function I/O pins
- Port 3 data register (PDR3)
- Port 3 direction register (DDR3)

(2) Block diagrams of port 3

• P30/SEG36/INT04 pin

This pin has the following peripheral functions:

- LCD SEG36 output pin (SEG36)
- External interrupt input pin (INT04)

• P31/SEG37/INT05 pin

This pin has the following peripheral functions:

- LCD SEG37 output pin (SEG37)
- External interrupt input pin (INT05)

• P32/SEG38/INT06 pin

This pin has the following peripheral functions:

- LCD SEG38 output pin (SEG38)
- External interrupt input pin (INT06)

• P33/SEG39/INT07 pin

This pin has the following peripheral functions:

- LCD SEG39 output pin (SEG39)
- External interrupt input pin (INT07)

• Block diagram of P30/SEG36/INT04, P31/SEG37/INT05, P32/SEG38/INT06 and P33/SEG39/INT07

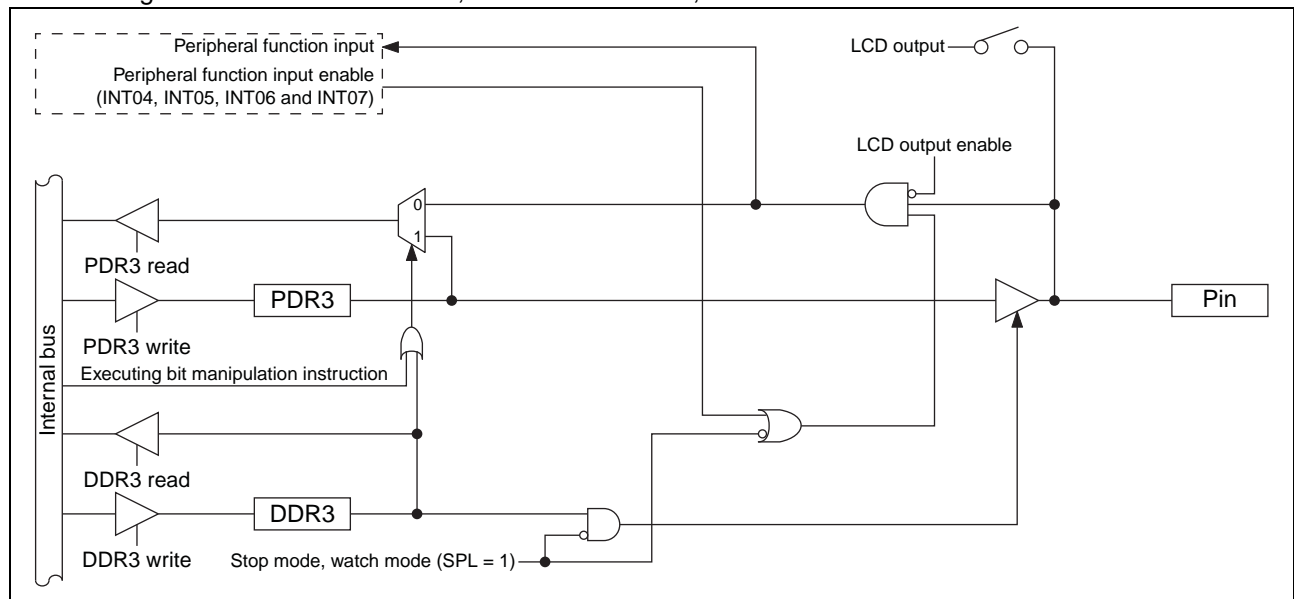

(Continued)

- P34/SEG40/TO11 pin
 - This pin has the following peripheral functions:
 - LCD SEG40 output pin (SEG40)
 - 8/16-bit composite timer ch. 1 output pin (TO11)
- P35/SEG41/TO10 pin
 - This pin has the following peripheral functions:
 - LCD SEG41 output pin (SEG41)
 - 8/16-bit composite timer ch. 1 output pin (TO10)
- P37/SEG43/TO0 pin
 - This pin has the following peripheral functions:
 - LCD SEG43 output pin (SEG43)
 - 16-bit reload timer ch. 0 output pin (TO0)
- Block diagram of P34/SEG40/TO11, P35/SEG41/TO11 and P37/SEG43/TO0

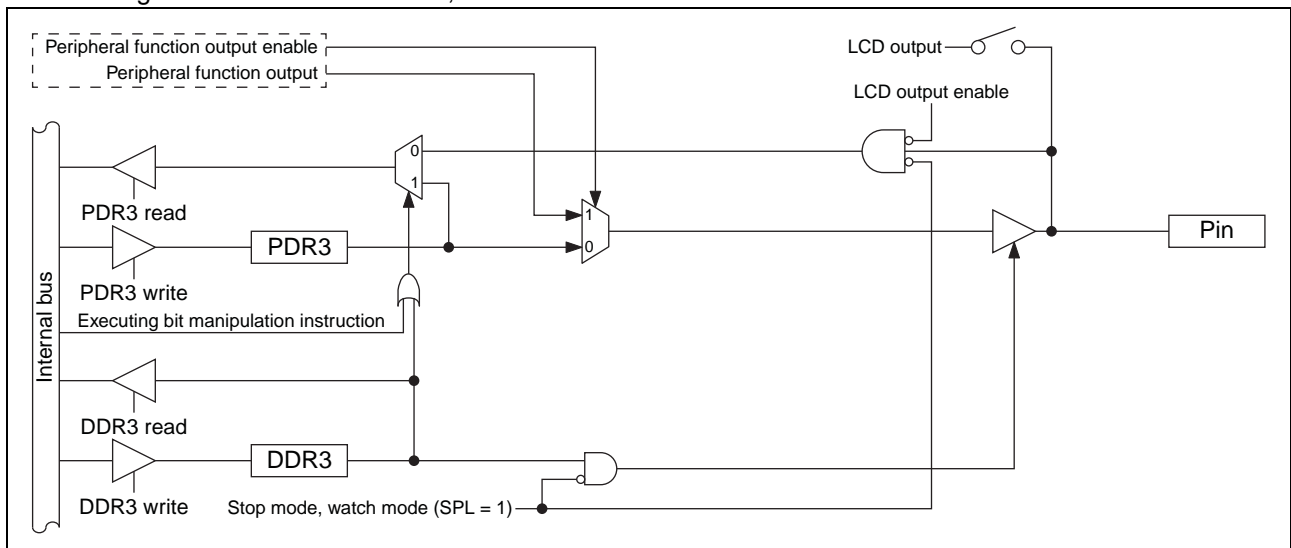

(Continued)

(3) Port 3 registers

- Port 3 register functions

Register abbreviation	Data	Read	Read by read-modify-write (RMW) instruction	Write
PDR3	0	Pin state is "L" level.	PDR3 value is "0".	As output port, outputs "L" level.
	1	Pin state is "H" level.	PDR3 value is "1".	As output port, outputs "H" level.
DDR3	0	Port input enabled		
	1	Port output enabled		

- Correspondence between registers and pins for port 3

	Correspondence between related register bits and pins							
Pin name	P37	P36	P35	P34	P33	P32	P31	P30
PDR3	bit7	bit6	bit5	bit4	bit3	bit2	bit1	bit0
DDR3								

(4) Port 3 operations

- Operation as an output port
 - A pin becomes an output port if the bit in the DDR3 register corresponding to that pin is set to “1”.
 - For a pin shared with other peripheral functions, disable the output of such peripheral functions.
 - When a pin is used as an output port, it outputs the value of the PDR3 register to external pins.
 - If data is written to the PDR3 register, the value is stored in the output latch and is output to the pin set as an output port as it is.
 - Reading the PDR3 register returns the PDR3 register value.
 - To use a pin shared with the LCDC as an output port, set a corresponding function select bit in the LCDC enable register 8 (LCDCE8:SEG[43:40]) or in the LCDC enable register 7 (LCDCE7:SEG[39:36]) to “0” to select the general-purpose I/O port function, and then set the port input control bit (PICTL) in the LCDC enable register 1 (LCDCE1) to “1”.
- Operation as an input port
 - A pin becomes an input port if the bit in the DDR3 register corresponding to that pin is set to “0”.
 - For a pin shared with other peripheral functions, disable the output of such peripheral functions.
 - If data is written to the PDR3 register, the value is stored in the output latch but is not output to the pin set as an input port.
 - Reading the PDR3 register returns the pin value. However, if the read-modify-write (RMW) type of instruction is used to read the PDR3 register, the PDR3 register value is returned.
 - To use a pin shared with the LCDC as an input port, set a corresponding function select bit in the LCDC enable register 8 (LCDCE8:SEG[43:40]) or in the LCDC enable register 7 (LCDCE7:SEG[39:36]) to “0” to select the general-purpose I/O port function, and then set the port input control bit (PICTL) in the LCDC enable register 1 (LCDCE1) to “1”.
- Operation as a peripheral function output pin
 - A pin becomes a peripheral function output pin if the peripheral output function is enabled by setting the output enable bit of a peripheral function corresponding to that pin.
 - The pin value can be read from the PDR3 register even if the peripheral function output is enabled. Therefore, the output value of a peripheral function can be read by the read operation on the PDR3 register. However, if the read-modify-write (RMW) type of instruction is used to read the PDR3 register, the PDR3 register value is returned.
- Operation as a peripheral function input pin
 - To set a pin as an input port, set the bit in the DDR3 register corresponding to the input pin of a peripheral function to “0”.
 - Reading the PDR3 register returns the pin value, regardless of whether the peripheral function uses that pin as its input pin. However, if the read-modify-write (RMW) type of instruction is used to read the PDR3 register, the PDR3 register value is returned.
- Operation as an LCDC segment output pin
 - Set the bit in the DDR3 register corresponding to a desired LCDC segment output pin to “0”.
 - Select the segment pin by setting a corresponding function select bit in the LCDC enable register 8 (LCDCE8:SEG[43:40]) or in the LCDC enable register 7 (LCDCE7:SEG[39:36]) to “1”, and then set the PICTL bit in the LCDCE1 register to “1”.
- Operation at reset

If the CPU is reset, all bits in the DDR3 register are initialized to “0” and port input is enabled.
- Operation in stop mode and watch mode
 - If the pin state setting bit in the standby control register (STBC:SPL) is set to “1” and the device transits to stop mode or watch mode, the pin is compulsorily made to enter the high impedance state regardless of the DDR3 register value. The input of that pin is locked to “L” level and blocked in order to prevent leaks due to input open. However, if the interrupt input is enabled for the external interrupt (INT04 to INT07), the input is enabled and not blocked.
 - If the pin state setting bit is “0”, the state of the port I/O or that of the peripheral function I/O remains unchanged and the output level is maintained.

(Continued)

(Continued)

- Operation as an external interrupt input pin
 - Set the bit in the DDR3 register corresponding to the external interrupt input pin to “0”.
 - For a pin shared with other peripheral functions, disable the output of such peripheral functions.
 - The pin value is always input to the external interrupt circuit. When using a pin for a function other than the interrupt, disable the external interrupt function corresponding to that pin.

5. Port 5

Port 5 is a general-purpose I/O port. This section focuses on its functions as a general-purpose I/O port. For details of peripheral functions, refer to their respective chapters in the hardware manual of the MB95610H Series.

(1) Port 5 configuration

Port 5 is made up of the following elements.

- General-purpose I/O pins/peripheral function I/O pins
- Port 5 data register (PDR5)
- Port 5 direction register (DDR5)
- Port 5 pull-up register (PUL5)

(2) Block diagrams of port 5

- P50/TO01 pin
 - This pin has the following peripheral function:
 - 8/16-bit composite time ch. 0 output pin (TO01)
- P52/TO00 pin
 - This pin has the following peripheral function:
 - 8/16-bit composite time ch. 0 output pin (TO00)
- Block diagram of P50/TO01 and P52/TO00

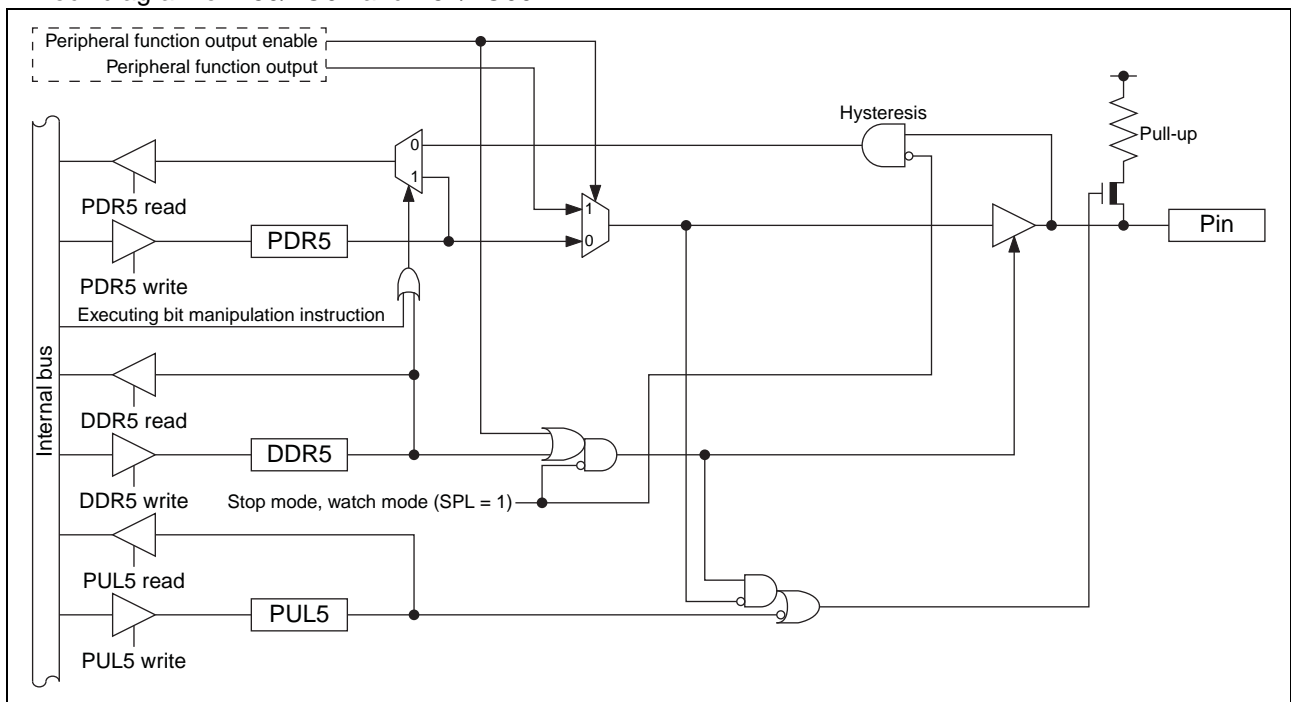

(Continued)

(Continued)

- P51/EC0 pin

This pin has the following peripheral function:

- 8/16-bit composite time ch. 0 clock input pin (EC0)

- Block diagram of P51/EC0

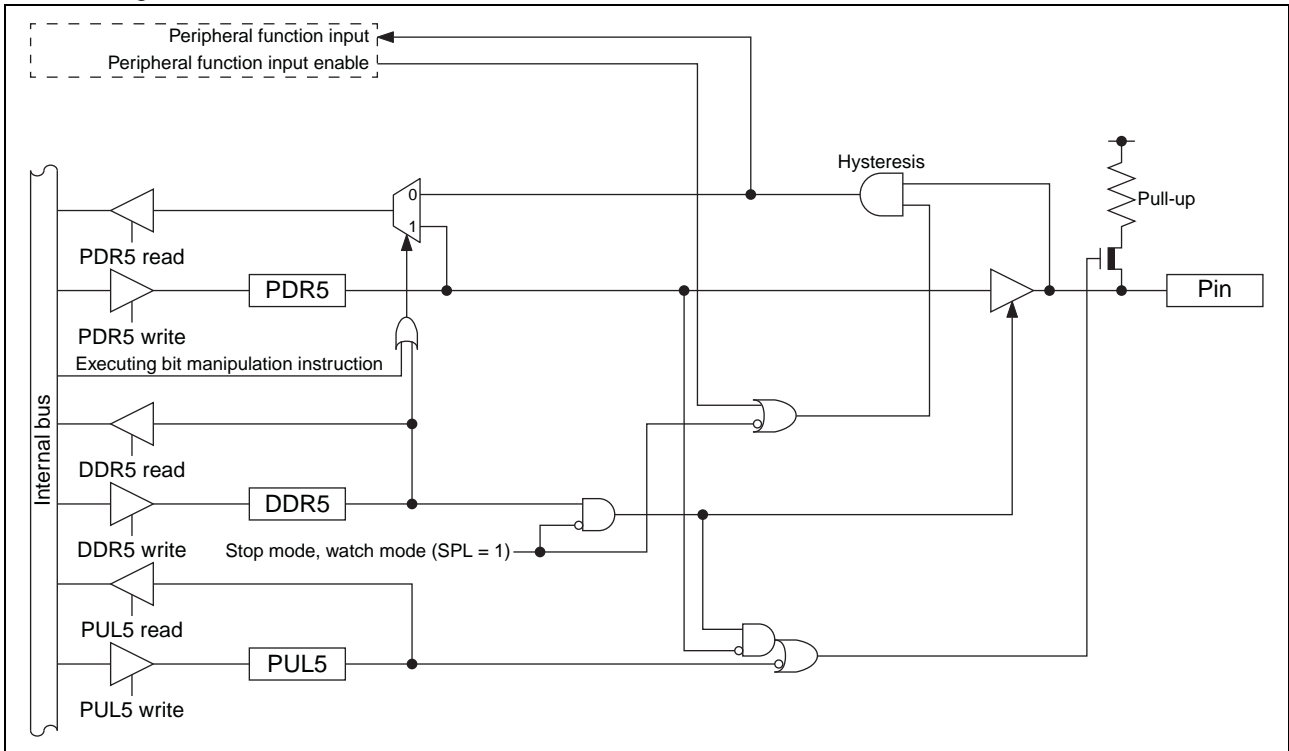

(3) Port 5 registers

- Port 5 register functions

Register abbreviation	Data	Read	Read by read-modify-write (RMW) instruction	Write
PDR5	0	Pin state is "L" level.	PDR5 value is "0".	As output port, outputs "L" level.
	1	Pin state is "H" level.	PDR5 value is "1".	As output port, outputs "H" level.
DDR5	0	Port input enabled		
	1	Port output enabled		
PUL5	0	Pull-up disabled		
	1	Pull-up enabled		

- Correspondence between registers and pins for port 5

	Correspondence between related register bits and pins							
Pin name	-	-	-	-	-	P52	P51	P50
PDR5								
DDR5	-	-	-	-	-	bit2	bit1	bit0
PUL5								

(4) Port 5 operations

- Operation as an output port
 - A pin becomes an output port if the bit in the DDR5 register corresponding to that pin is set to “1”.
 - For a pin shared with other peripheral functions, disable the output of such peripheral functions.
 - When a pin is used as an output port, it outputs the value of the PDR5 register to external pins.
 - If data is written to the PDR5 register, the value is stored in the output latch and is output to the pin set as an output port as it is.
 - Reading the PDR5 register returns the PDR5 register value.
- Operation as an input port
 - A pin becomes an input port if the bit in the DDR5 register corresponding to that pin is set to “0”.
 - For a pin shared with other peripheral functions, disable the output of such peripheral functions.
 - If data is written to the PDR5 register, the value is stored in the output latch but is not output to the pin set as an input port.
 - Reading the PDR5 register returns the pin value. However, if the read-modify-write (RMW) type of instruction is used to read the PDR5 register, the PDR5 register value is returned.
- Operation as a peripheral function output pin
 - A pin becomes a peripheral function output pin if the peripheral output function is enabled by setting the output enable bit of a peripheral function corresponding to that pin.
 - The pin value can be read from the PDR5 register even if the peripheral function output is enabled. Therefore, the output value of a peripheral function can be read by the read operation on the PDR5 register. However, if the read-modify-write (RMW) type of instruction is used to read the PDR5 register, the PDR5 register value is returned.
- Operation as a peripheral function input pin
 - To set a pin as an input port, set the bit in the DDR5 register corresponding to the input pin of a peripheral function to “0”.
 - Reading the PDR5 register returns the pin value, regardless of whether the peripheral function uses that pin as its input pin. However, if the read-modify-write (RMW) type of instruction is used to read the PDR5 register, the PDR5 register value is returned.
- Operation at reset

If the CPU is reset, all bits in the DDR5 register are initialized to “0” and port input is enabled.
- Operation in stop mode and watch mode
 - If the pin state setting bit in the standby control register (STBC:SPL) is set to “1” and the device transits to stop mode or watch mode, the pin is compulsorily made to enter the high impedance state regardless of the DDR5 register value. The input of that pin is locked to “L” level and blocked in order to prevent leaks due to input open. However, if the interrupt input of P51/EC0 is enabled by the external interrupt control register ch. 0 (EIC00) of the external interrupt circuit and the interrupt pin selection circuit control register (WICR) of the interrupt pin selection circuit, the input is enabled and is not blocked.
 - If the pin state setting bit is “0”, the state of the port I/O or that of the peripheral function I/O remains unchanged and the output level is maintained.
- Operation of the pull-up register

Setting the bit in the PUL5 register to “1” makes the pull-up resistor be internally connected to the pin. When the pin output is “L” level, the pull-up resistor is disconnected regardless of the value of the PUL5 register.

6. Port 9

Port 9 is a general-purpose I/O port. This section focuses on its functions as a general-purpose I/O port. For details of peripheral functions, refer to their respective chapters in the hardware manual of the MB95610H Series.

(1) Port 9 configuration

Port 9 is made up of the following elements.

- General-purpose I/O pins/peripheral function I/O pins
- Port 9 data register (PDR9)
- Port 9 direction register (DDR9)

(2) Block diagrams of port 9

- P90/V4 pin
This pin has the following peripheral function:
 - LCDC drive power supply pin (V4)
- P91/V3 pin
This pin has the following peripheral function:
 - LCDC drive power supply pin (V3)
- P92/V2 pin
This pin has the following peripheral function:
 - LCDC drive power supply pin (V2)
- P93/V1 pin
This pin has the following peripheral function:
 - LCDC drive power supply pin (V1)
- P94/V0 pin
This pin has the following peripheral function:
 - LCDC drive power supply pin (V0)
- Block diagram of P90/V4, P91/V3, P92/V2, P93/V1 and P94/V0

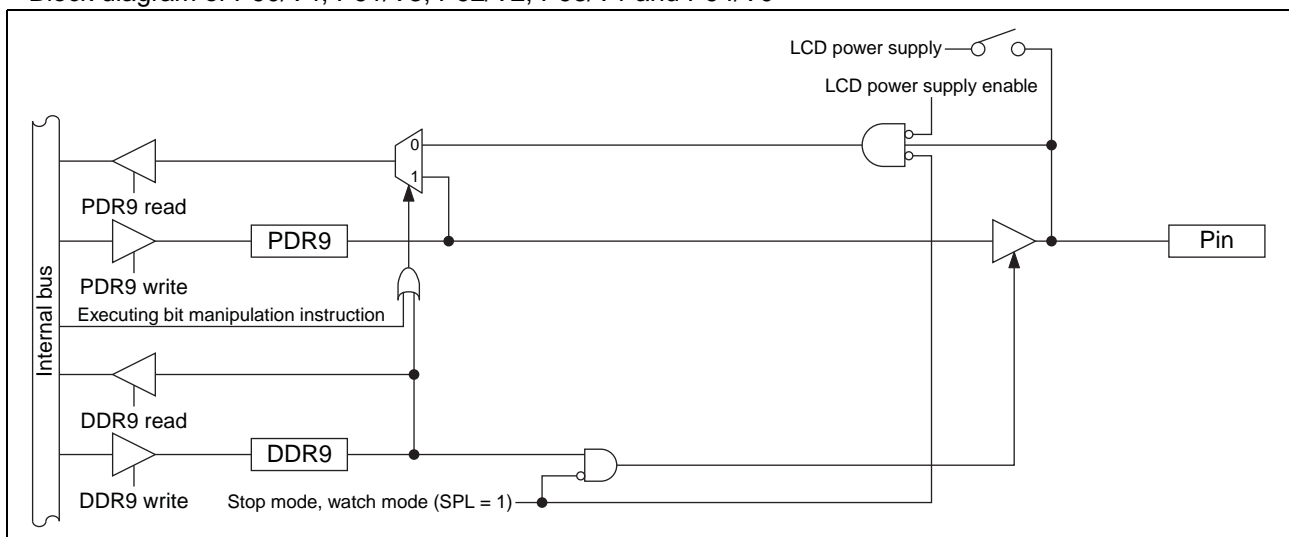

(3) Port 9 registers

- Port 9 register functions

Register abbreviation	Data	Read	Read by read-modify-write (RMW) instruction	Write
PDR9	0	Pin state is "L" level.	PDR9 value is "0".	As output port, outputs "L" level.
	1	Pin state is "H" level.	PDR9 value is "1".	As output port, outputs "H" level.
DDR9	0	Port input enabled		
	1	Port output enabled		

- Correspondence between registers and pins for port 9

	Correspondence between related register bits and pins							
Pin name	-	-	-	P94	P93	P92	P91	P90
PDR9	-	-	-	bit4	bit3	bit2	bit1	bit0
DDR9	-	-	-					

(4) Port 9 operations

- Operation as an output port
 - A pin becomes an output port if the bit in the DDR9 register corresponding to that pin is set to “1”.
 - For a pin shared with other peripheral functions, disable the output of such peripheral functions.
 - When a pin is used as an output port, it outputs the value of the PDR9 register to external pins.
 - If data is written to the PDR9 register, the value is stored in the output latch and is output to the pin set as an output port as it is.
 - Reading the PDR9 register returns the PDR9 register value.
 - To use a pin shared with the LCDC as an output port, set the bit corresponding to that pin in the VE[4:0] bits in the LCDC enable register 1 (LCDCE1) to “0”.

- Operation as an input port
 - A pin becomes an input port if the bit in the DDR9 register corresponding to that pin is set to “0”.
 - For a pin shared with other peripheral functions, disable the output of such peripheral functions.
 - If data is written to the PDR9 register, the value is stored in the output latch but is not output to the pin set as an input port.
 - Reading the PDR9 register returns the pin value. However, if the read-modify-write (RMW) type of instruction is used to read the PDR9 register, the PDR9 register value is returned.
 - To use a pin shared with the LCDC as an input port, set the bit (VE[4:0]) corresponding to that pin in the LCDCE1 register to “0”.

- Operation at reset

If the CPU is reset, all bits in the DDR9 register are initialized to “0” and port input is enabled.

- Operation in stop mode and watch mode
 - If the pin state setting bit in the standby control register (STBC:SPL) is set to “1” and the device transits to stop mode or watch mode, the pin is compulsorily made to enter the high impedance state regardless of the DDR9 register value. The input of that pin is locked to “L” level and blocked in order to prevent leaks due to input open.
 - If the pin state setting bit is “0”, the state of the port I/O or that of the peripheral function I/O remains unchanged and the output level is maintained.

- Operation as an LCDC drive power supply pin
 - Set the bit in the DDR9 register corresponding to a desired LCDC drive power supply pin to “0”.
 - Select the LCDC drive power supply pin by setting the bit corresponding to that pin in the VE[4:0] bits in the LCDCE1 register to “1”.

7. Port F

Port F is a general-purpose I/O port. This section focuses on its functions as a general-purpose I/O port. For details of peripheral functions, refer to their respective chapters in the hardware manual of the MB95610H Series.

(1) Port F configuration

Port F is made up of the following elements.

- General-purpose I/O pins/peripheral function I/O pins
- Port F data register (PDRF)
- Port F direction register (DDRF)

(2) Block diagrams of port F

• PF0/X0 pin

This pin has the following peripheral function:

- Main clock input oscillation pin (X0)

• PF1/X1 pin

This pin has the following peripheral function:

- Main clock I/O oscillation pin (X1)

• Block diagram of PF0/X0 and PF1/X1

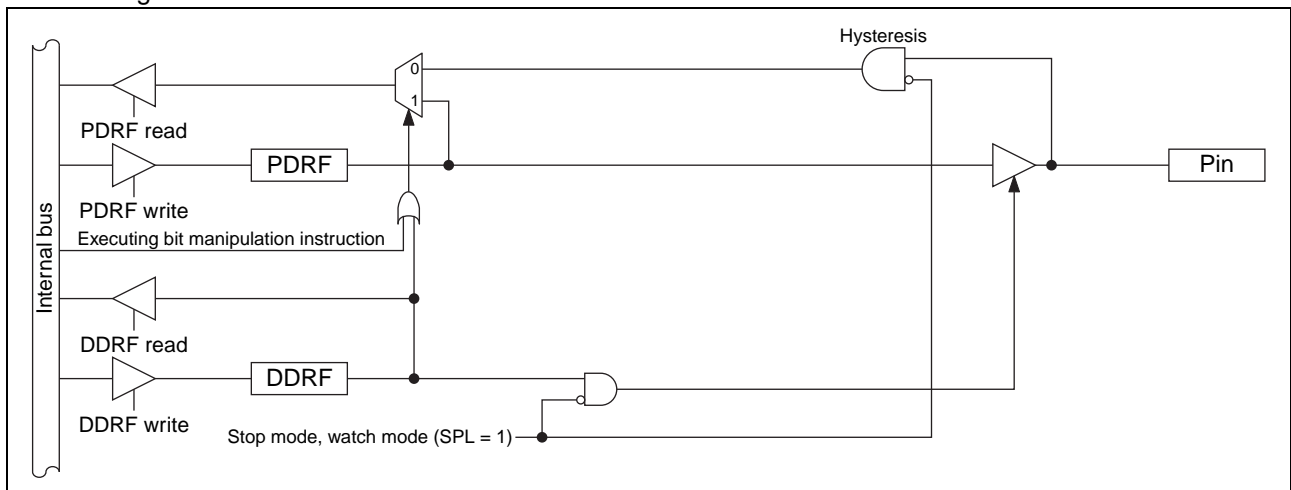

(Continued)

(Continued)

• PF2/ $\overline{\text{RST}}$ pin

This pin has the following peripheral function:

- Reset pin ($\overline{\text{RST}}$)

• Block diagram of PF2/ $\overline{\text{RST}}$

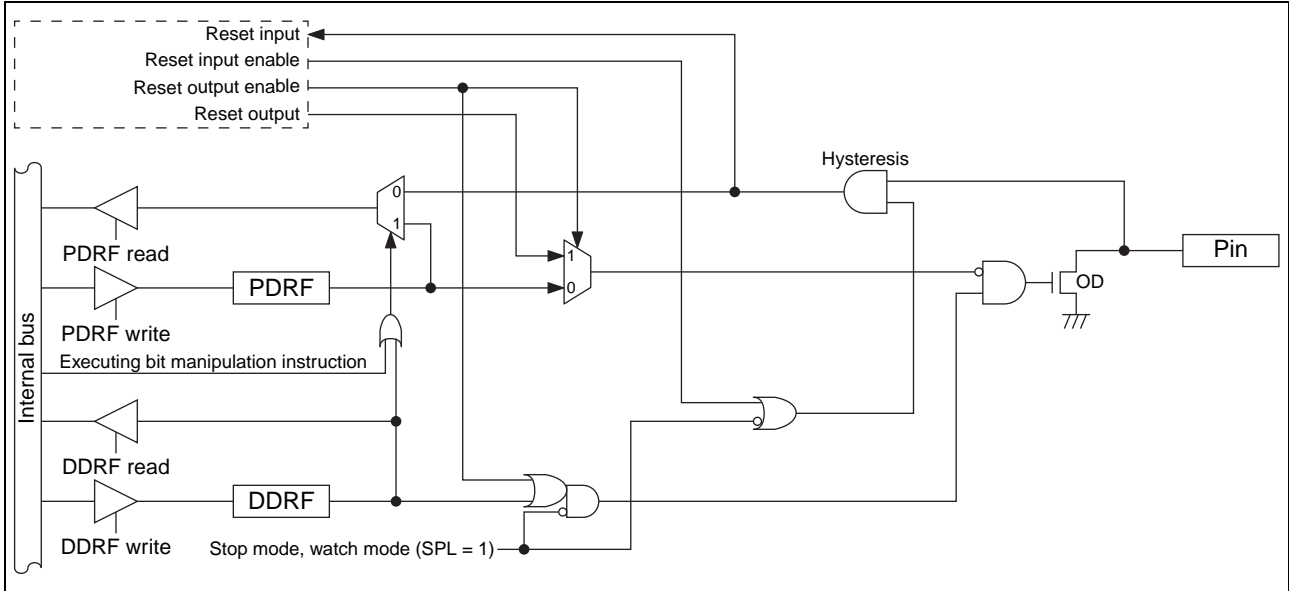

(3) Port F registers

- Port F register functions

Register abbreviation	Data	Read	Read by read-modify-write (RMW) instruction	Write
PDRF	0	Pin state is "L" level.	PDRF value is "0".	As output port, outputs "L" level.
	1	Pin state is "H" level.	PDRF value is "1".	As output port, outputs "H" level.*
DDRF	0	Port input enabled		
	1	Port output enabled		

*: If the pin is an N-ch open drain pin, the pin state becomes Hi-Z.

- Correspondence between registers and pins for port F

Pin name	Correspondence between related register bits and pins							
	-	-	-	-	-	PF2*	PF1	PF0
PDRF	-	-	-	-	-	bit2	bit1	bit0
DDRF	-	-	-	-	-			

*: PF2/ $\overline{\text{RST}}$ is the dedicated reset pin on MB95F613H/F614H/F616H.

(4) Port F operations

- Operation as an output port
 - A pin becomes an output port if the bit in the DDRF register corresponding to that pin is set to “1”.
 - For a pin shared with other peripheral functions, disable the output of such peripheral functions.
 - When a pin is used as an output port, it outputs the value of the PDRF register to external pins.
 - If data is written to the PDRF register, the value is stored in the output latch and is output to the pin set as an output port as it is.
 - Reading the PDRF register returns the PDRF register value.

- Operation as an input port
 - A pin becomes an input port if the bit in the DDRF register corresponding to that pin is set to “0”.
 - For a pin shared with other peripheral functions, disable the output of such peripheral functions.
 - If data is written to the PDRF register, the value is stored in the output latch but is not output to the pin set as an input port.
 - Reading the PDRF register returns the pin value. However, if the read-modify-write (RMW) type of instruction is used to read the PDRF register, the PDRF register value is returned.

- Operation at reset

If the CPU is reset, all bits in the DDRF register are initialized to “0” and port input is enabled.

- Operation in stop mode and watch mode
 - If the pin state setting bit in the standby control register (STBC:SPL) is set to “1” and the device transits to stop mode or watch mode, the pin is compulsorily made to enter the high impedance state regardless of the DDRF register value. The input of that pin is locked to “L” level and blocked in order to prevent leaks due to input open.
 - If the pin state setting bit is “0”, the state of the port I/O or that of the peripheral function I/O remains unchanged and the output level is maintained.

8. Port G

Port G is a general-purpose I/O port. This section focuses on its functions as a general-purpose I/O port. For details of peripheral functions, refer to their respective chapters in the hardware manual of the MB95610H Series.

(1) Port G configuration

Port G is made up of the following elements.

- General-purpose I/O pins/peripheral function I/O pins
- Port G data register (PDRG)
- Port G direction register (DDRG)
- Port G pull-up register (PULG)

(2) Block diagram of port G

• PG1/X0A pin

This pin has the following peripheral function:

- Subclock input oscillation pin (X0A)

• PG2/X1A pin

This pin has the following peripheral function:

- Subclock I/O oscillation pin (X1A)

• Block diagram of PG1/X0A and PG2/X1A

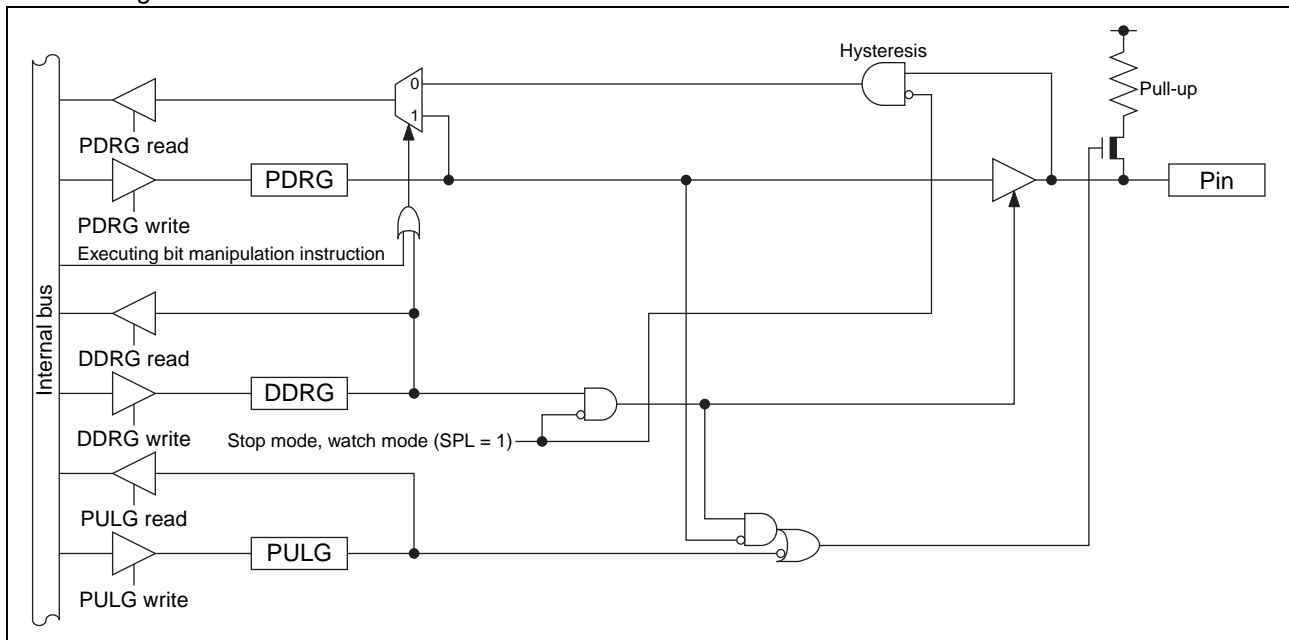

(3) Port G registers

- Port G register functions

Register abbreviation	Data	Read	Read by read-modify-write (RMW) instruction	Write
PDRG	0	Pin state is "L" level.	PDRG value is "0".	As output port, outputs "L" level.
	1	Pin state is "H" level.	PDRG value is "1".	As output port, outputs "H" level.
DDRG	0	Port input enabled		
	1	Port output enabled		
PULG	0	Pull-up disabled		
	1	Pull-up enabled		

- Correspondence between registers and pins for port G

	Correspondence between related register bits and pins							
Pin name	-	-	-	-	-	PG2	PG1	-
PDRG								
DDRG	-	-	-	-	-	bit2	bit1	-
PULG								

(4) Port G operations

- Operation as an output port
 - A pin becomes an output port if the bit in the DDRG register corresponding to that pin is set to “1”.
 - For a pin shared with other peripheral functions, disable the output of such peripheral functions.
 - When a pin is used as an output port, it outputs the value of the PDRG register to external pins.
 - If data is written to the PDRG register, the value is stored in the output latch and is output to the pin set as an output port as it is.
 - Reading the PDRG register returns the PDRG register value.
- Operation as an input port
 - A pin becomes an input port if the bit in the DDRG register corresponding to that pin is set to “0”.
 - For a pin shared with other peripheral functions, disable the output of such peripheral functions.
 - If data is written to the PDRG register, the value is stored in the output latch but is not output to the pin set as an input port.
 - Reading the PDRG register returns the pin value. However, if the read-modify-write (RMW) type of instruction is used to read the PDRG register, the PDRG register value is returned.
- Operation as a peripheral function input pin
 - To set a pin as an input port, set the bit in the DDRG register corresponding to the input pin of a peripheral function to “0”.
 - Reading the PDRG register returns the pin value, regardless of whether the peripheral function uses that pin as its input pin. However, if the read-modify-write (RMW) type of instruction is used to read the PDRG register, the PDRG register value is returned.
- Operation at reset

If the CPU is reset, all bits in the DDRG register are initialized to “0” and port input is enabled.
- Operation in stop mode and watch mode
 - If the pin state setting bit in the standby control register (STBC:SPL) is set to “1” and the device transits to stop mode or watch mode, the pin is compulsorily made to enter the high impedance state regardless of the DDRG register value. The input of that pin is locked to “L” level and blocked in order to prevent leaks due to input open.
 - If the pin state setting bit is “0”, the state of the port I/O or that of the peripheral function I/O remains unchanged and the output level is maintained.
- Operation of the pull-up register

Setting the bit in the PULG register to “1” makes the pull-up resistor be internally connected to the pin. When the pin output is “L” level, the pull-up resistor is disconnected regardless of the value of the PULG register.

■ INTERRUPT SOURCE TABLE

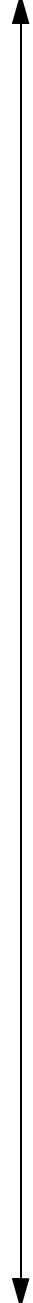
Interrupt source	Interrupt request number	Vector table address		Interrupt level setting register		Priority order of interrupt sources of the same level (occurring simultaneously)
		Upper	Lower	Register	Bit	
External interrupt ch. 0	IRQ00	0xFFFA	0xFFFB	ILR0	L00 [1:0]	High  Low
External interrupt ch. 4						
External interrupt ch. 1	IRQ01	0xFFF8	0xFFF9	ILR0	L01 [1:0]	
External interrupt ch. 5						
External interrupt ch. 2	IRQ02	0xFFF6	0xFFF7	ILR0	L02 [1:0]	
External interrupt ch. 6						
External interrupt ch. 3	IRQ03	0xFFF4	0xFFF5	ILR0	L03 [1:0]	
External interrupt ch. 7						
UART/SIO ch. 0	IRQ04	0xFFF2	0xFFF3	ILR1	L04 [1:0]	
8/16-bit composite timer ch. 0 (lower)	IRQ05	0xFFF0	0xFFF1	ILR1	L05 [1:0]	
8/16-bit composite timer ch. 0 (upper)	IRQ06	0xFFEE	0xFFEF	ILR1	L06 [1:0]	
—	IRQ07	0xFFEC	0xFFED	ILR1	L07 [1:0]	
LCDC	IRQ08	0xFFEA	0xFFEB	ILR2	L08 [1:0]	
8/16-bit PPG ch. 1 (lower)	IRQ09	0xFFE8	0xFFE9	ILR2	L09 [1:0]	
UART/SIO ch. 1						
8/16-bit PPG ch. 1 (upper)	IRQ10	0xFFE6	0xFFE7	ILR2	L10 [1:0]	
16-bit reload timer ch. 0	IRQ11	0xFFE4	0xFFE5	ILR2	L11 [1:0]	
8/16-bit PPG ch. 0 (upper)	IRQ12	0xFFE2	0xFFE3	ILR3	L12 [1:0]	
8/16-bit PPG ch. 0 (lower)	IRQ13	0xFFE0	0xFFE1	ILR3	L13 [1:0]	
8/16-bit composite timer ch. 1 (upper)	IRQ14	0xFFDE	0xFFDF	ILR3	L14 [1:0]	
—	IRQ15	0xFFDC	0xFFDD	ILR3	L15 [1:0]	
I ² C bus interface ch. 0	IRQ16	0xFFDA	0xFFDB	ILR4	L16 [1:0]	
—	IRQ17	0xFFD8	0xFFD9	ILR4	L17 [1:0]	
8/10-bit A/D converter	IRQ18	0xFFD6	0xFFD7	ILR4	L18 [1:0]	
Time-base timer	IRQ19	0xFFD4	0xFFD5	ILR4	L19 [1:0]	
Watch prescaler	IRQ20	0xFFD2	0xFFD3	ILR5	L20 [1:0]	
Watch counter						
—	IRQ21	0xFFD0	0xFFD1	ILR5	L21 [1:0]	
8/16-bit composite timer ch. 1 (lower)	IRQ22	0xFFCE	0xFFCF	ILR5	L22 [1:0]	
Flash memory	IRQ23	0xFFCC	0xFFCD	ILR5	L23 [1:0]	

■ PIN STATES IN EACH MODE

Pin name	Normal operation	Sleep mode	Stop mode		Watch mode		On reset
			SPL=0	SPL=1	SPL=0	SPL=1	
PF0/X0	Oscillation input	Oscillation input	Hi-Z	Hi-Z	Hi-Z	Hi-Z	—
	I/O port*1	I/O port*1	- Previous state kept - Input blocked*1, *2	- Hi-Z - Input blocked*1, *2	- Previous state kept - Input blocked*1, *2	- Hi-Z - Input blocked*1, *2	- Hi-Z - Input enabled*3 (However, it does not function.)
PF1/X1	Oscillation input	Oscillation input	Hi-Z	Hi-Z	Hi-Z	Hi-Z	—
	I/O port*1	I/O port*1	- Previous state kept - Input blocked*1, *2	- Hi-Z - Input blocked*1, *2	- Previous state kept - Input blocked*1, *2	- Hi-Z - Input blocked*1, *2	- Hi-Z - Input enabled*3 (However, it does not function.)
PF2/RST	Reset input	Reset input	Reset input	Reset input	Reset input	Reset input	Reset input*4
	I/O port*1	I/O port*1	- Previous state kept - Input blocked*1, *2	- Hi-Z - Input blocked*1, *2	- Previous state kept - Input blocked*1, *2	- Hi-Z - Input blocked*1, *2	- Hi-Z - Input enabled*3 (However, it does not function.)
PG1/X0A	Oscillation input	Oscillation input	Hi-Z	Hi-Z	Hi-Z	Hi-Z	—
	I/O port*1	I/O port*1	- Previous state kept - Input blocked*1, *2	- Hi-Z - Input blocked*1, *2	- Previous state kept - Input blocked*1, *2	- Hi-Z - Input blocked*1, *2	- Hi-Z - Input enabled*3 (However, it does not function.)
PG2/X1A	Oscillation input	Oscillation input	Hi-Z	Hi-Z	Hi-Z	Hi-Z	—
	I/O port*1	I/O port*1	- Previous state kept - Input blocked*1, *2	- Hi-Z - Input blocked*1, *2	- Previous state kept - Input blocked*1, *2	- Hi-Z - Input blocked*1, *2	- Hi-Z - Input enabled*3 (However, it does not function.)
P00/INT00/ AN00	I/O port/ peripheral function I/O/ analog input	I/O port/ peripheral function I/O/ analog input	- Previous state kept - Input blocked*2, *5	- Hi-Z - Input blocked*2, *5	- Previous state kept - Input blocked*2, *5	- Hi-Z - Input blocked*2, *5	- Hi-Z - Input blocked*2
P01/INT01/ AN01							
P02/INT02/ AN02							
P03/INT03/ AN03							
P04/SEG32	I/O port/ peripheral function I/O/ analog input	I/O port/ peripheral function I/O/ analog input	- Previous state kept - Input blocked*2	- Hi-Z - Input blocked*2	- Previous state kept - Input blocked*2	- Hi-Z - Input blocked*2	- Hi-Z - Input blocked*2
P05/SEG33/ ADTG							
P06/SEG34/ PPG10							
P07/SEG35/ PPG11							

(Continued)

Pin name	Normal operation	Sleep mode	Stop mode		Watch mode		On reset
			SPL=0	SPL=1	SPL=0	SPL=1	
P12/DBG	I/O port/ peripheral function I/O	I/O port/ peripheral function I/O	- Previous state kept - Input blocked*2	- Hi-Z - Input blocked*2	- Previous state kept - Input blocked*2	- Hi-Z - Input blocked*2	- Hi-Z - Input enabled*3 (However, it does not function.)
P13/UO0	I/O port/ peripheral function I/O	I/O port/ peripheral function I/O	- Previous state kept - Input blocked*2	- Hi-Z*6 - Input blocked*2	- Previous state kept - Input blocked*2	- Hi-Z*6 - Input blocked*2	- Hi-Z - Input enabled*3 (However, it does not function.)
P14/UCK0							
P15/UI0							
P20/SEG44/ TI0	I/O port/ peripheral function I/O	I/O port/ peripheral function I/O	- Previous state kept - Input blocked*2, *7	- Hi-Z - Input blocked*2, *7	- Previous state kept - Input blocked*2, *7	- Hi-Z - Input blocked*2, *7	- Hi-Z - Input enabled*3 (However, it does not function.)
P21/SEG45/ UO1							
P22/SEG46/ UCK1							
P23/SEG47/ UI1							
P24/SEG48/ PPG00							
P25/SEG49/ PPG01							
P26/SEG50/ SCL							
P27/SEG51/ SDA							
P30/SEG36/ INT04	I/O port/ peripheral function I/O	I/O port/ peripheral function I/O	- Previous state kept - Input blocked*2*5	- Hi-Z - Input blocked*2*5	- Previous state kept - Input blocked*2*5	- Hi-Z - Input blocked*2*5	- Hi-Z - Input enabled*3 (However, it does not function.)
P31/SEG37/ INT05							
P32/SEG38/ INT06							
P33/SEG39/ INT07							
P34/SEG40/ TO11	I/O port/ peripheral function I/O	I/O port/ peripheral function I/O	- Previous state kept - Input blocked*2	- Hi-Z - Input blocked*2	- Previous state kept - Input blocked*2	- Hi-Z - Input blocked*2	- Hi-Z - Input enabled*3 (However, it does not function.)
P35/SEG41/ TO10							
P36/SEG42/ EC1							
P37/SEG43/ TO0							
P50/TO01	I/O port/ peripheral function I/O	I/O port/ peripheral function I/O	- Previous state kept - Input blocked*2	- Hi-Z*6 - Input blocked*2	- Previous state kept - Input blocked*2	- Hi-Z*6 - Input blocked*2	- Hi-Z - Input enabled*3 (However, it does not function.)
P51/EC0							
P52/TO00							
P90/V4	I/O port/ peripheral function I/O	I/O port/ peripheral function I/O	- Previous state kept - Input blocked*2	- Hi-Z - Input blocked*2	- Previous state kept - Input blocked*2	- Hi-Z - Input blocked*2	- Hi-Z - Input blocked*2
P91/V3							
P92/V2							
P93/V1							

(Continued)

(Continued)

Pin name	Normal operation	Sleep mode	Stop mode		Watch mode		On reset
			SPL=0	SPL=1	SPL=0	SPL=1	
COM0	Analog output	Analog output	- Previous state kept - Input blocked*2	- Hi-Z - Input blocked*2	- Previous state kept - Input blocked*2	- Hi-Z - Input blocked*2	- Hi-Z - Input blocked*2
COM1							
COM2							
COM3							
COM4/ SEG00							
COM5/ SEG01							
COM6/ SEG02							
COM7/ SEG03							
SEG04	Analog output	Analog output	- Previous state kept - Input blocked*2	- Hi-Z - Input blocked*2	- Previous state kept - Input blocked*2	- Hi-Z - Input blocked*2	- Hi-Z - Input blocked*2
SEG05							
SEG06							
SEG07							
SEG08							
SEG09							
SEG10							
SEG11							
SEG12							
SEG13							
SEG14							
SEG15							
SEG16							
SEG17							
SEG18							
SEG19							
SEG20							
SEG21							
SEG22							
SEG23							
SEG24							
SEG25							
SEG26							
SEG27							
SEG28							
SEG29							
SEG30							
SEG31							

SPL: Pin state setting bit in the standby control register (STBC:SPL)

Hi-Z: High impedance

*1: The pin stays at the state shown when configured as a general-purpose I/O port.

*2: "Input blocked" means direct input gate operation from the pin is disabled.

*3: "Input enabled" means that the input function is enabled. While the input function is enabled, a pull-up or pull-down operation has to be performed in order to prevent leaks due to external input. If a pin is used as an output port, its pin state is the same as that of other ports.

*4: The PF2/ \overline{RST} pin stays at the state shown when configured as a reset pin.

*5: Though input is blocked, an external interrupt can be input when the external interrupt request is enabled.

*6: The pull-up control setting is still effective.

*7: The I²C bus interface can wake up the MCU in stop mode or watch mode when its MCU standby mode wakeup function is enabled. For details of the MCU standby mode wakeup function, refer to "CHAPTER 23 I²C BUS INTERFACE" in the hardware manual of the MB95610H Series.

■ ELECTRICAL CHARACTERISTICS

1. Absolute Maximum Ratings

Parameter	Symbol	Rating		Unit	Remarks
		Min	Max		
Power supply voltage*1	V _{CC}	V _{SS} - 0.3	V _{SS} + 6	V	
Input voltage*1	V _I	V _{SS} - 0.3	V _{SS} + 6	V	*2
Output voltage*1	V _O	V _{SS} - 0.3	V _{SS} + 6	V	*2
Maximum clamp current	I _{CLAMP}	-2	+2	mA	Applicable to specific pins*3
Total maximum clamp current	$\Sigma I_{CLAMP} $	—	20	mA	Applicable to specific pins*3
"L" level maximum output current	I _{OL}	—	15	mA	
"L" level average current	I _{OLAV}	—	4	mA	Average output current = operating current × operating ratio (1 pin)
"L" level total maximum output current	ΣI_{OL}	—	100	mA	
"L" level total average output current	ΣI_{OLAV}	—	50	mA	Total average output current = operating current × operating ratio (Total number of pins)
"H" level maximum output current	I _{OH}	—	-15	mA	
"H" level average current	I _{OHAV}	—	-4	mA	Average output current = operating current × operating ratio (1 pin)
"H" level total maximum output current	ΣI_{OH}	—	-100	mA	
"H" level total average output current	ΣI_{OHAV}	—	-50	mA	Total average output current = operating current × operating ratio (Total number of pins)
Power consumption	P _d	—	320	mW	
Operating temperature	T _A	-40	+85	°C	
Storage temperature	T _{stg}	-55	+150	°C	

(Continued)

(Continued)

*1: These parameters are based on the condition that V_{SS} is 0.0 V.

*2: V_1 and V_0 must not exceed $V_{CC} + 0.3$ V. V_1 must not exceed the rated voltage. However, if the maximum current to/from an input is limited by means of an external component, the I_{CLAMP} rating is used instead of the V_1 rating

*3: Specific pins: P00 to P07, P12 to P15, P20 to P27, P30 to P37, P50 to P52, P90 to P94

- Use under recommended operating conditions.
- Use with DC voltage (current).
- The HV (High Voltage) signal is an input signal exceeding the V_{CC} voltage. Always connect a limiting resistor between the HV (High Voltage) signal and the microcontroller before applying the HV (High Voltage) signal.
- The value of the limiting resistor should be set to a value at which the current to be input to the microcontroller pin when the HV (High Voltage) signal is input is below the standard value, irrespective of whether the current is transient current or stationary current.
- When the microcontroller drive current is low, such as in low power consumption modes, the HV (High Voltage) input potential may pass through the protective diode to increase the potential of the V_{CC} pin, affecting other devices.
- If the HV (High Voltage) signal is input when the microcontroller power supply is off (not fixed at 0 V), since power is supplied from the pins, incomplete operations may be executed.
- If the HV (High Voltage) input is input after power-on, since power is supplied from the pins, the voltage of power supply may not be sufficient to enable a power-on reset.
- Do not leave the HV (High Voltage) input pin unconnected.
- Example of a recommended circuit:

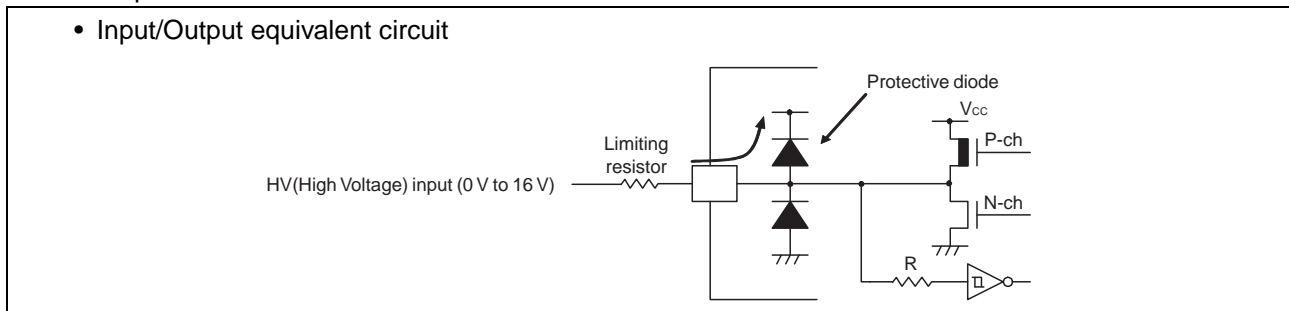

WARNING: Semiconductor devices can be permanently damaged by application of stress (voltage, current, temperature, etc.) in excess of absolute maximum ratings. Do not exceed these ratings.

2. Recommended Operating Conditions

(V_{SS} = 0.0 V)

Parameter	Symbol	Value		Unit	Remarks
		Min	Max		
Power supply voltage	V _{CC}	2.4*1	5.5	V	In normal operation
		2.3	5.5	V	Hold condition in stop mode
Decoupling capacitor	C _s	0.022	1	μF	*2
Operating temperature	T _A	- 40	+85	°C	Not in on-chip debug mode
		+5	+35		In on-chip debug mode

*1: The minimum value becomes 2.88 V when the low-voltage detection reset is used or when the device is in on-chip debug mode.

*2: Use a ceramic capacitor or a capacitor with equivalent frequency characteristics. The decoupling capacitor for the V_{CC} pin must have a capacitance larger than C_s. For the connection to a decoupling capacitor C_s, see the diagram below. To prevent the device from unintentionally entering an unknown mode due to noise, minimize the distance between the C pin and C_s and the distance between C_s and the V_{SS} pin when designing the layout of a printed circuit board.

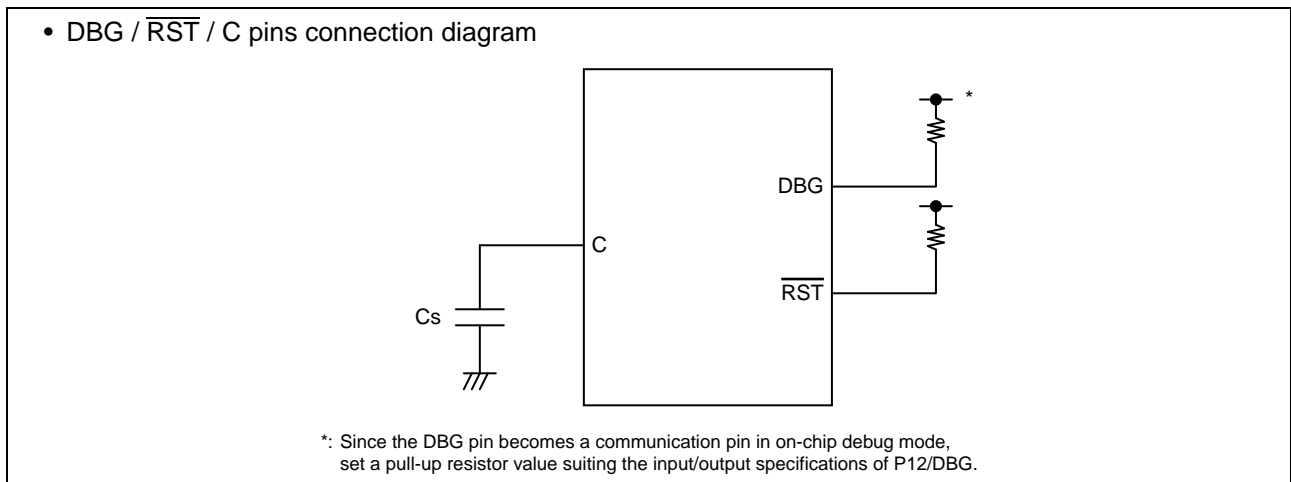

WARNING: The recommended operating conditions are required in order to ensure the normal operation of the semiconductor device. All of the device's electrical characteristics are warranted when the device is operated within these ranges.

Always use semiconductor devices within their recommended operating condition ranges. Operation outside these ranges may adversely affect reliability and could result in device failure. No warranty is made with respect to uses, operating conditions, or combinations not represented on the data sheet. Users considering application outside the listed conditions are advised to contact their representatives beforehand.

3. DC Characteristics

($V_{CC} = 5.0\text{ V} \pm 10\%$, $V_{SS} = 0.0\text{ V}$, $T_A = -40\text{ }^\circ\text{C}$ to $+85\text{ }^\circ\text{C}$)

Parameter	Symbol	Pin name	Condition	Value			Unit	Remarks
				Min	Typ	Max		
"H" level input voltage	V_{IH1}	P15, P23, P26, P27	—	$0.7 V_{CC}$	—	$V_{CC} + 0.3$	V	Hysteresis input
	V_{IH5}	P00 to P07, P12 to P14, P20 to P22, P24, P25, P30 to P37, P50 to P52, P90 to P94, PF0 to PF2, PG1, PG2	—	$0.8 V_{CC}$	—	$V_{CC} + 0.3$	V	Hysteresis input
"L" level input voltage	V_{IL1}	P15, P23, P26, P27	—	$V_{SS} - 0.3$	—	$0.3 V_{CC}$	V	Hysteresis input
	V_{IL5}	P00 to P07, P12 to P14, P20 to P22, P24, P25, P30 to P37, P50 to P52, P90 to P94, PF0 to PF2, PG1, PG2	—	$V_{SS} - 0.3$	—	$0.2 V_{CC}$	V	Hysteresis input
Open-drain output application voltage	V_D	P12, PF2	—	$V_{SS} - 0.3$	—	$V_{SS} + 5.5$	V	
"H" level output voltage	V_{OH}	P00 to P07, P13 to P15, P20 to P27, P30 to P37, P50 to P52, P90 to P94, PF0, PF1, PG1, PG2	$I_{OH} = -4\text{ mA}$	$V_{CC} - 0.5$	—	—	V	
"L" level output voltage	V_{OL}	P00 to P07, P12 to P15, P20 to P27, P30 to P37, P50 to P52, P90 to P94, PF0 to PF2, PG1, PG2	$I_{OL} = 4\text{ mA}$	—	—	0.4	V	

(Continued)

(V_{CC} = 5.0 V±10%, V_{SS} = 0.0 V, T_A = -40 °C to +85 °C)

Parameter	Symbol	Pin name	Condition	Value			Unit	Remarks
				Min	Typ	Max		
Input leak current (Hi-Z output leak current)	I _{LI}	P00 to P07, P12 to P15, P20 to P27, P30 to P37, P50 to P52, P90 to P94, PF0 to PF2 PG1, PG2	0.0 V < V _I < V _{CC}	-5	—	+5	μA	When pull-up resistance is disabled
Pull-up resistance	R _{PULL}	P13 to P15, P50 to P52, PG1, PG2*1	V _I = 0 V	25	50	100	kΩ	When pull-up resistance is enabled
Input capacitance	C _{IN}	Other than V _{CC} and V _{SS}	f = 1 MHz	—	5	15	pF	
Power supply current*1	I _{CC}	V _{CC} (External clock operation)	F _{CH} = 32 MHz F _{MP} = 16 MHz Main clock mode (divided by 2)	—	4.5	5.8	mA	Except during Flash memory programming and erasing
				—	10.0	13.8	mA	During Flash memory programming and erasing
				—	6.3	9.1	mA	At A/D conversion
	I _{CCS}		F _{CH} = 32 MHz F _{MP} = 16 MHz Main sleep mode (divided by 2)	—	2.0	3.0	mA	
	I _{CCCL}		F _{CL} = 32 kHz F _{MPL} = 16 kHz Subclock mode (divided by 2) T _A = +25 °C	—	60	100	μA	
	I _{CCLS} *2		F _{CL} = 32 kHz F _{MPL} = 16 kHz Subsleep mode (divided by 2) T _A = +25 °C	—	10	15	μA	
	I _{CCCT} *2		F _{CL} = 32 kHz Watch mode Main stop mode T _A = +25 °C	—	8	13	μA	

(Continued)

(V_{CC} = 5.0 V±10%, V_{SS} = 0.0 V, T_A = -40 °C to +85 °C)

Parameter	Symbol	Pin name	Condition	Value			Unit	Remarks
				Min	Typ	Max		
Power supply current*1	I _{CCMPLL}	V _{CC}	F _{MCRPLL} = 16 MHz F _{MP} = 16 MHz Main CR PLL clock mode (multiplied by 4) T _A = +25 °C	—	5.5	6.8	mA	
	I _{CCMCR}		F _{CRH} = 4 MHz F _{MP} = 4 MHz Main CR clock mode	—	1.4	2.0	mA	
	I _{CCSCR}		Sub-CR clock mode (divided by 2) T _A = +25 °C	—	70	150	μA	
	I _{CCTS}	V _{CC} (External clock operation)	F _{CH} = 32 MHz Time-base timer mode T _A = +25 °C	—	360	410	μA	
	I _{CCH}		Substop mode T _A = +25 °C	—	7	11	μA	
	I _{LVD}	V _{CC}	Current consumption of the low-voltage detection reset circuit	—	4	7	μA	The low-voltage detection reset circuit operates only in on-chip debug mode.
	I _{CRH}		Current consumption of the main CR oscillator	—	240	320	μA	
	I _{CRL}		Current consumption of the sub-CR oscillator oscillating at 100 kHz	—	7	20	μA	
	I _{INSTBY}		Current consumption difference between normal standby mode and deep standby mode T _A = +25 °C	—	20	30	μA	

(Continued)

(Continued)

(V_{CC} = 5.0 V \pm 10%, V_{SS} = 0.0 V, T_A = -40 °C to +85 °C)

Parameter	Symbol	Pin name	Condition	Value			Unit	Remarks
				Min	Typ	Max		
LCD internal division resistance	R _{LCD}	—	Between V4 and V _{SS}	—	20	—	k Ω	1/2 bias, 10 k Ω resistor
				—	200	—	k Ω	1/2 bias, 100 k Ω resistor
				—	40	—	k Ω	1/4 bias, 10 k Ω resistor
				—	400	—	k Ω	1/4 bias, 100 k Ω resistor
COM0 to COM7 output impedance	R _{VCOM}	COM0 to COM7	V1 to V4 = 4.1 V	—	—	5	k Ω	
SEG00 to SEG51 output impedance	R _{VSEG}	SEG00 to SEG51		—	—	7	k Ω	
LCD leakage current	I _{LCDL}	V0 to V4, COM0 to COM7, SEG00 to SEG51	—	-1	—	+1	k Ω	

*1: • The power supply current is determined by the external clock. When the low-voltage detection reset circuit is selected, the power supply current is the sum of adding the current consumption of the low-voltage detection reset circuit (I_{LVD}) to one of the values from I_{CC} to I_{CCCH}. When both the low-voltage detection reset circuit and a CR oscillator are selected, the power supply current is the sum of adding up the current consumption of the low-voltage detection reset circuit (I_{LVD}), the current consumption of the CR oscillator (I_{CRH} or I_{CRL}) and one of the values from I_{CC} to I_{CCCH}. In on-chip debug mode, the main CR oscillator (I_{CRH}) and the low-voltage detection reset circuit are always in operation, and current consumption therefore increases accordingly.

- See "4. AC Characteristics (1) Clock Timing" for F_{CH}, F_{CL}, F_{CRH} and F_{MCRPLL}.
- See "4. AC Characteristics (2) Source Clock/Machine Clock" for F_{MP} and F_{MPL}.
- The power supply current value in standby mode is measured in deep standby mode. The current consumption in normal standby is higher than that in deep standby mode. The power supply current value in normal standby can be found by adding the current consumption difference between normal standby mode and deep standby mode (I_{INSTBY}) to the power supply current value in deep standby mode. For details of normal standby and deep standby mode, refer to "CHAPTER 3 CLOCK CONTROLLER" in the hardware manual of the MB95610H Series.

*2: In sub-CR clock mode, the power supply current is the sum of adding I_{CCLS} or I_{CCCT} to I_{CRH}.

4. AC Characteristics

(1) Clock Timing

($V_{CC} = 2.4\text{ V to }5.5\text{ V}$, $V_{SS} = 0.0\text{ V}$, $T_A = -40\text{ }^\circ\text{C to }+85\text{ }^\circ\text{C}$)

Parameter	Symbol	Pin name	Condition	Value			Unit	Remarks	
				Min	Typ	Max			
Clock frequency	F _{CH}	X0, X1	—	1	—	16.25	MHz	When the main oscillation circuit is used	
		X0	X1: open	1	—	12	MHz	When the main external clock is used	
		X0, X1	*	1	—	32.5	MHz		
		X0, X1	—	—	4	—	8.13	MHz	Operating conditions • The main clock is used. • PLL multiplier: 2
					4	—	6.5	MHz	Operating conditions • The main clock is used. • PLL multiplier: 2.5
					4	—	5.41	MHz	Operating conditions • The main clock is used. • PLL multiplier: 3
	4				—	4.06	MHz	Operating conditions • The main clock is used. • PLL multiplier: 4	
	F _{CRH}	—	—	3.92	4	4.08	MHz	Operating conditions • The main CR clock is used. • $0\text{ }^\circ\text{C} \leq T_A \leq +70\text{ }^\circ\text{C}$	
				3.9	4	4.1	MHz	Operating conditions • The main CR clock is used. • $-40\text{ }^\circ\text{C} \leq T_A < 0\text{ }^\circ\text{C}$, $+70\text{ }^\circ\text{C} < T_A \leq +85\text{ }^\circ\text{C}$	

(Continued)

(V_{CC} = 2.4 V to 5.5 V, V_{SS} = 0.0 V, T_A = -40 °C to +85 °C)

Parameter	Symbol	Pin name	Condition	Value			Unit	Remarks
				Min	Typ	Max		
Clock frequency	F _{MCRPLL}	—	—	7.84	8	8.16	MHz	Operating conditions • PLL multiplier: 2 • 0 °C ≤ T _A ≤ +70 °C
				7.6	8	8.4	MHz	Operating conditions • PLL multiplier: 2 • -40 °C ≤ T _A < 0 °C, +70 °C < T _A ≤ +85 °C
				9.8	10	10.2	MHz	Operating conditions • PLL multiplier: 2.5 • 0 °C ≤ T _A ≤ +70 °C
				9.5	10	10.5	MHz	Operating conditions • PLL multiplier: 2.5 • -40 °C ≤ T _A < 0 °C, +70 °C < T _A ≤ +85 °C
				11.76	12	12.24	MHz	Operating conditions • PLL multiplier: 3 • 0 °C ≤ T _A ≤ +70 °C
				11.4	12	12.6	MHz	Operating conditions • PLL multiplier: 3 • -40 °C ≤ T _A < 0 °C, +70 °C < T _A ≤ +85 °C
				15.68	16	16.32	MHz	Operating conditions • PLL multiplier: 4 • 0 °C ≤ T _A ≤ +70 °C
				15.2	16	16.8	MHz	Operating conditions • PLL multiplier: 4 • -40 °C ≤ T _A < 0 °C, +70 °C < T _A ≤ +85 °C
	F _{CL}	X0A, X1A	—	—	32.768	—	kHz	When the sub-oscillation circuit is used
				—	32.768	—	kHz	When the sub-external clock is used
F _{CRL}	—	—	50	100	150	kHz	When the sub-CR clock is used	

(Continued)

(Continued)

(V_{CC} = 2.4 V to 5.5 V, V_{SS} = 0.0 V, T_A = -40 °C to +85 °C)

Parameter	Symbol	Pin name	Condition	Value			Unit	Remarks
				Min	Typ	Max		
Clock cycle time	t _{H CYL}	X0, X1	—	61.5	—	1000	ns	When the main oscillation circuit is used
		X0	X1: open	83.4	—	1000	ns	When an external clock is used
		X0, X1	*	30.8	—	1000	ns	
	t _{L CYL}	X0A, X1A	—	—	30.5	—	μs	When the subclock is used
Input clock pulse width	t _{WH1}	X0	X1: open	33.4	—	—	ns	When an external clock is used, the duty ratio should range between 40% and 60%.
	t _{WL1}	X0, X1	*	14.4	15.2	—	ns	
	t _{WH2} t _{WL2}	X0A	—	—	30.5	—	μs	
Input clock rise time and fall time	t _{CR}	X0	X1: open	—	—	5	ns	When an external clock is used
	t _{CF}	X0, X1	*	—	—	5	ns	
CR oscillation start time	t _{CRHWK}	—	—	—	—	50	μs	When the main CR clock is used
	t _{CRLWK}	—	—	—	—	30	μs	When the sub-CR clock is used
PLL oscillation start time	t _{MCRPLLWK}	—	—	—	—	100	μs	When the main CR PLL clock is used

*: The external clock signal is input to X0 and the inverted external clock signal to X1.

- Input waveform generated when an external clock (main clock) is used

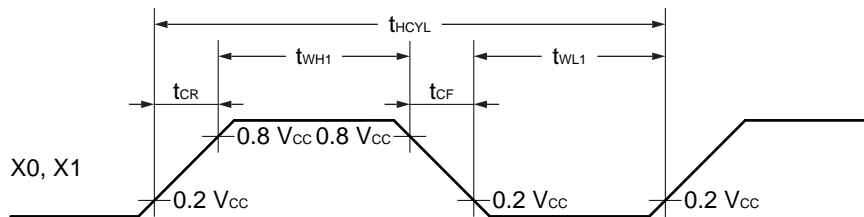

- Figure of main clock input port external connection

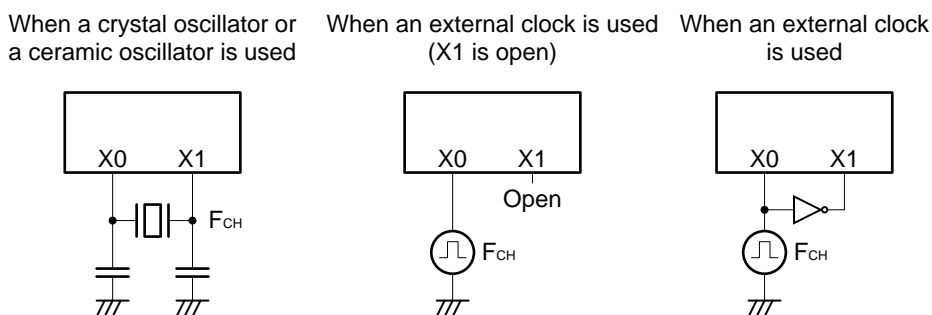

- Input waveform generated when an external clock (subclock) is used

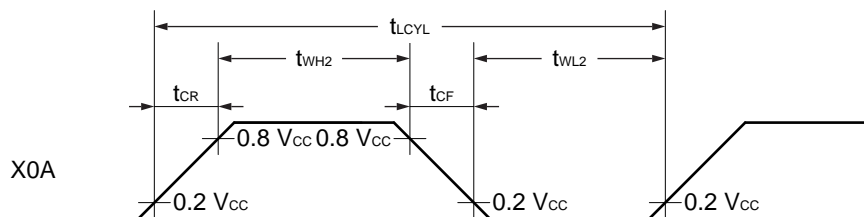

- Figure of subclock input port external connection

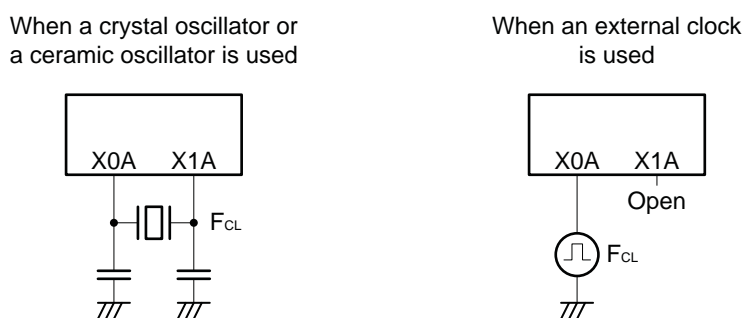

- Input waveform generated when an internal clock (main CR clock) is used

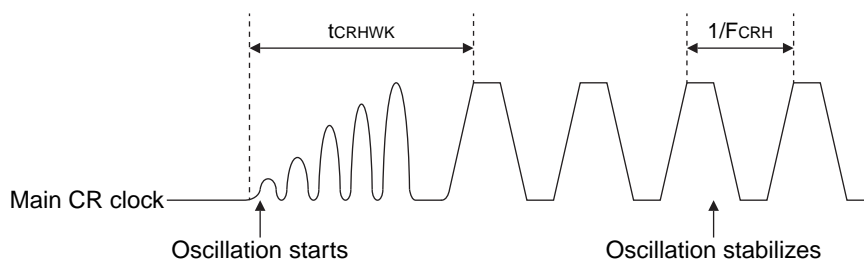

- Input waveform generated when an internal clock (sub-CR clock) is used

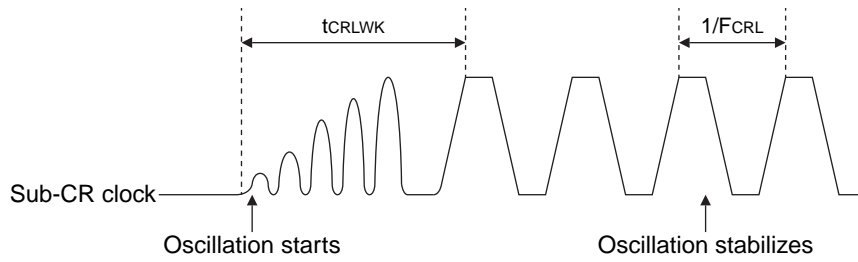

- Input waveform generated when an internal clock (main CR PLL clock) is used

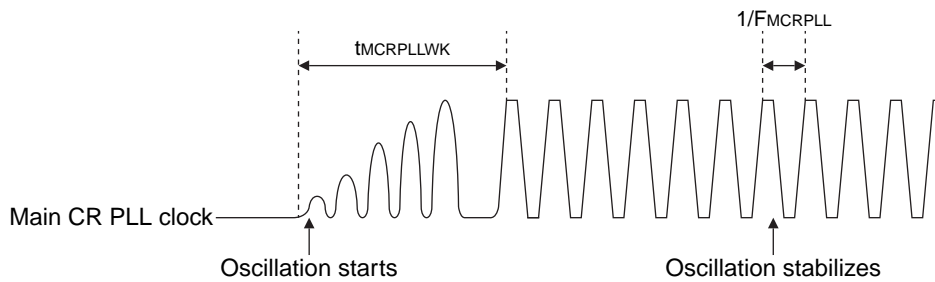

(2) Source Clock/Machine Clock

(V_{CC} = 5.0 V \pm 10%, V_{SS} = 0.0 V, T_A = -40 °C to +85 °C)

Parameter	Symbol	Pin name	Value			Unit	Remarks
			Min	Typ	Max		
Source clock cycle time*1	t _{SCLK}	—	61.5	—	2000	ns	When the main external clock is used Min: F _{CH} = 32.5 MHz, divided by 2 Max: F _{CH} = 1 MHz, divided by 2
			62.5	—	1000	ns	When the main CR clock is used Min: F _{CRH} = 4 MHz, multiplied by 4 Max: F _{CRH} = 4 MHz, divided by 4
			—	61	—	μs	When the sub-oscillation clock is used F _{CL} = 32.768 kHz, divided by 2
			—	20	—	μs	When the sub-CR clock is used F _{CRL} = 100 kHz, divided by 2
Source clock frequency	F _{SP}	—	0.5	—	16.25	MHz	When the main oscillation clock is used
			—	4	12.5	MHz	When the main CR clock is used
	—		16.384	—	kHz	When the sub-oscillation clock is used	
	F _{SPL}		—	50	—	kHz	When the sub-CR clock is used F _{CRL} = 100 kHz, divided by 2
Machine clock cycle time*2 (minimum instruction execution time)	t _{MCLK}	—	61.5	—	32000	ns	When the main oscillation clock is used Min: F _{SP} = 16.25 MHz, no division Max: F _{SP} = 0.5 MHz, divided by 16
			250	—	4000	ns	When the main CR clock is used Min: F _{SP} = 4 MHz, no division Max: F _{SP} = 4 MHz, divided by 16
			61	—	976.5	μs	When the sub-oscillation clock is used Min: F _{SPL} = 16.384 kHz, no division Max: F _{SPL} = 16.384 kHz, divided by 16
			20	—	320	μs	When the sub-CR clock is used Min: F _{SPL} = 50 kHz, no division Max: F _{SPL} = 50 kHz, divided by 16
Machine clock frequency	F _{MPL}	—	0.031	—	16.25	MHz	When the main oscillation clock is used
			0.25	—	16	MHz	When the main CR clock is used
	1.024		—	16.384	kHz	When the sub-oscillation clock is used	
	F _{MPL}		3.125	—	50	kHz	When the sub-CR clock is used F _{CRL} = 100 kHz

*1: This is the clock before it is divided according to the division ratio set by the machine clock division ratio select bits (SYCC:DIV[1:0]). This source clock is divided to become a machine clock according to the division ratio set by the machine clock division ratio select bits (SYCC:DIV[1:0]). In addition, a source clock can be selected from the following.

- Main clock divided by 2
- PLL multiplication of main clock or main CR clock (Select a multiplier from 2, 2.5, 3 and 4.)
- Main CR clock
- Subclock divided by 2
- Sub-CR clock divided by 2

*2: This is the operating clock of the microcontroller. A machine clock can be selected from the following.

- Source clock (no division)
- Source clock divided by 4
- Source clock divided by 8
- Source clock divided by 16

• Schematic diagram of the clock generation block

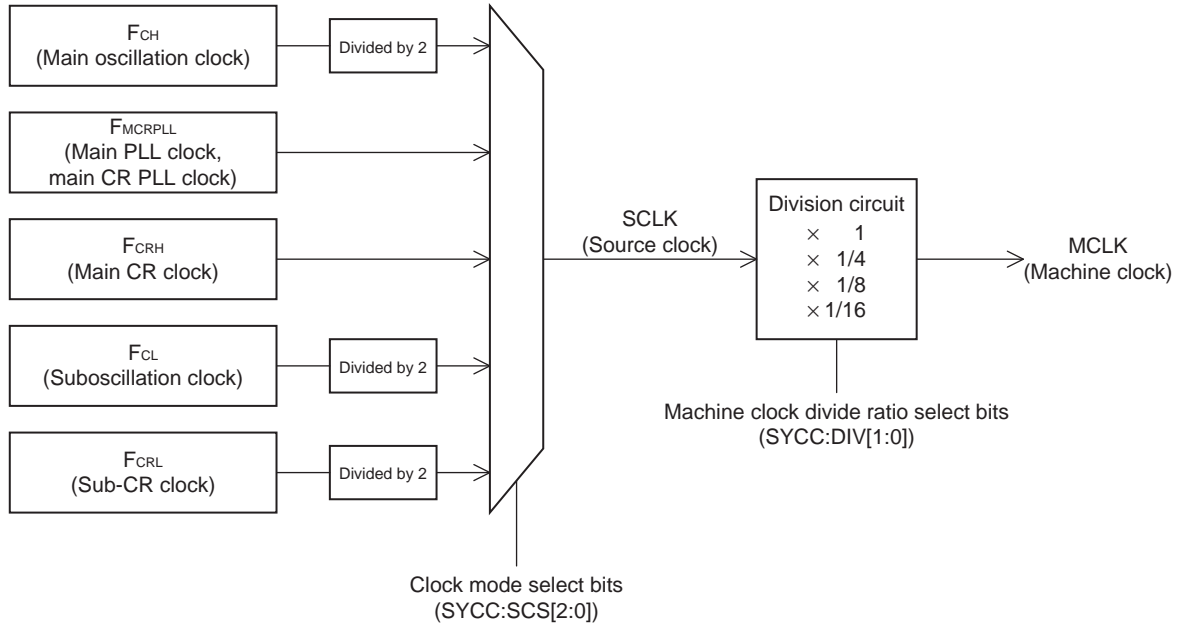

• Operating voltage - Operating frequency ($T_A = -40\text{ }^\circ\text{C}$ to $+85\text{ }^\circ\text{C}$)

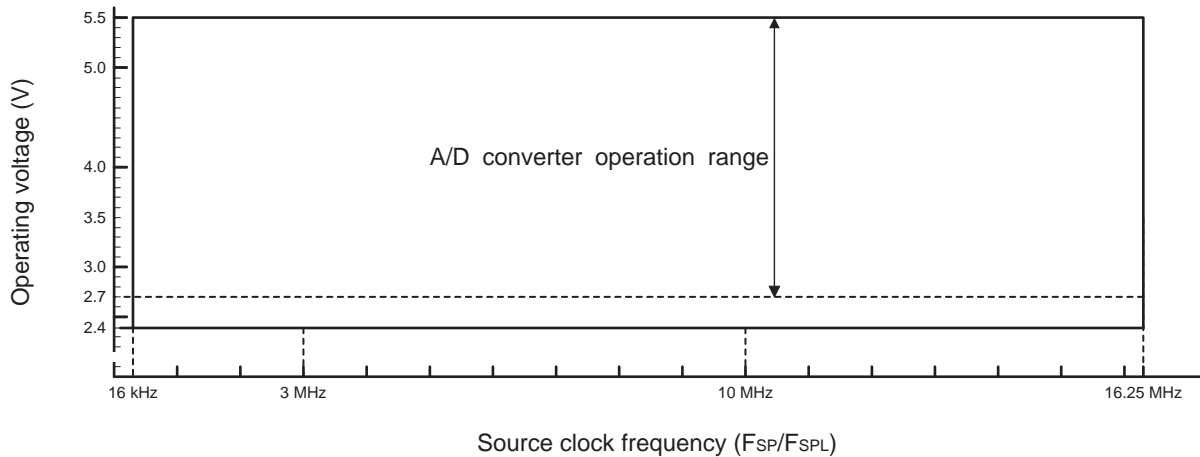

(3) External Reset

($V_{CC} = 5.0\text{ V} \pm 10\%$, $V_{SS} = 0.0\text{ V}$, $T_A = -40\text{ }^\circ\text{C}$ to $+85\text{ }^\circ\text{C}$)

Parameter	Symbol	Value		Unit	Remarks
		Min	Max		
$\overline{\text{RST}}$ "L" level pulse width	t_{RSTL}	$2\ t_{\text{MCLK}}^*$	—	ns	

*: See "(2) Source Clock/Machine Clock" for t_{MCLK} .

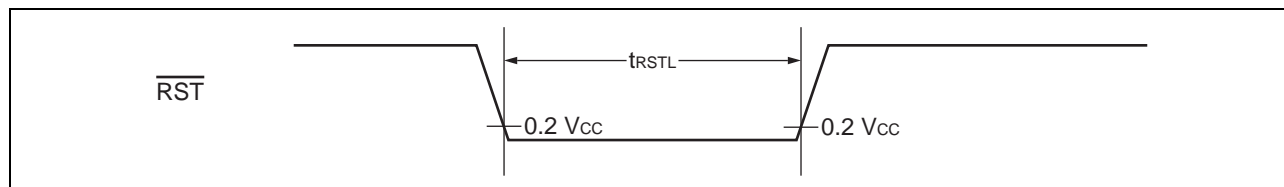

(4) Power-on reset

($V_{SS} = 0.0\text{ V}$, $T_A = -40\text{ }^\circ\text{C}$ to $+85\text{ }^\circ\text{C}$)

Parameter	Symbol	Condition	Value		Unit	Remarks
			Min	Max		
Power supply rising time	t_R	—	—	50	ms	
Power supply cutoff time	t_{OFF}	—	1	—	ms	Wait time until power-on

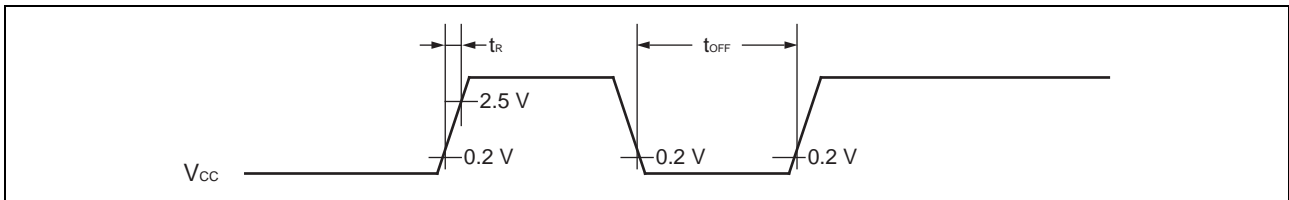

Note: A sudden change of power supply voltage may activate the power-on reset function. When changing the power supply voltage during the operation, set the slope of rising to a value below within 30 mV/ms as shown below.

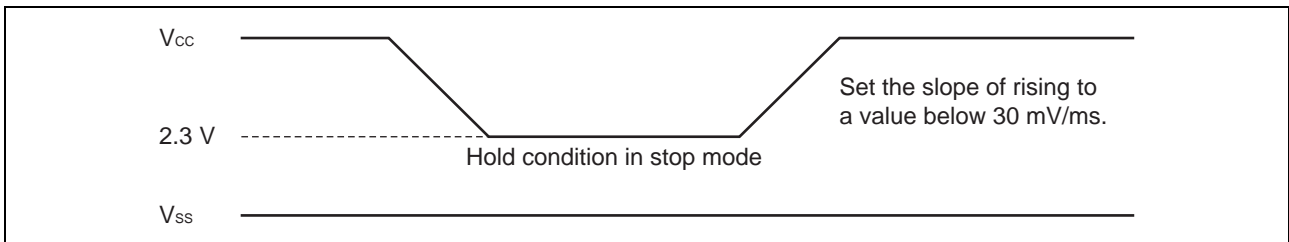

(5) Peripheral Input Timing

($V_{CC} = 5.0 V \pm 10\%$, $V_{SS} = 0.0 V$, $T_A = -40\text{ }^\circ\text{C}$ to $+85\text{ }^\circ\text{C}$)

Parameter	Symbol	Pin name	Value		Unit
			Min	Max	
Peripheral input "H" pulse width	t_{LH}	INT00 to INT07, EC0, EC1,	2 t_{MCLK}^*	—	ns
Peripheral input "L" pulse width	t_{HL}	ADTG, TIO	2 t_{MCLK}^*	—	ns

*: See "(2) Source Clock/Machine Clock" for t_{MCLK} .

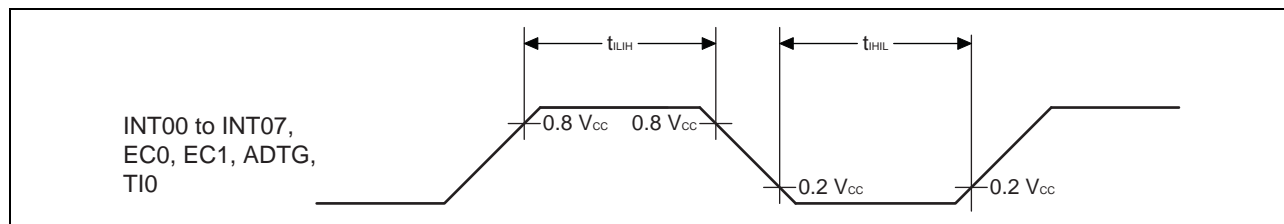

(6) Low-voltage Detection

($V_{SS} = 0.0\text{ V}$, $T_A = -40\text{ }^\circ\text{C}$ to $+85\text{ }^\circ\text{C}$)

Parameter	Symbol	Value			Unit	Remarks
		Min	Typ	Max		
Release voltage*	V_{DL+}	2.52	2.7	2.88	V	At power supply rise
		2.61	2.8	2.99		
		2.89	3.1	3.31		
		3.08	3.3	3.52		
Detection voltage*	V_{DL-}	2.43	2.6	2.77	V	At power supply fall
		2.52	2.7	2.88		
		2.80	3	3.20		
		2.99	3.2	3.41		
Hysteresis width	V_{HYS}	—	—	100	mV	
Power supply start voltage	V_{off}	—	—	2.3	V	
Power supply end voltage	V_{on}	4.9	—	—	V	
Power supply voltage change time (at power supply rise)	t_r	650	—	—	μs	Slope of power supply that the reset release signal generates within the rating (V_{DL+})
Power supply voltage change time (at power supply fall)	t_f	650	—	—	μs	Slope of power supply that the reset release signal generates within the rating (V_{DL-})
Reset release delay time	t_{d1}	—	—	30	μs	
Reset detection delay time	t_{d2}	—	—	30	μs	
LVD reset threshold voltage transition stabilization time	t_{stb}	10	—	—	μs	

*: The release voltage and the detection voltage can be selected by using the LVD reset voltage selection ID register (LVDR) in the low-voltage detection reset circuit. For details of the LVDR register, refer to "CHAPTER 16 LOW-VOLTAGE DETECTION RESET CIRCUIT" in the hardware manual of the MB95610H Series.

(Continued)

(Continued)

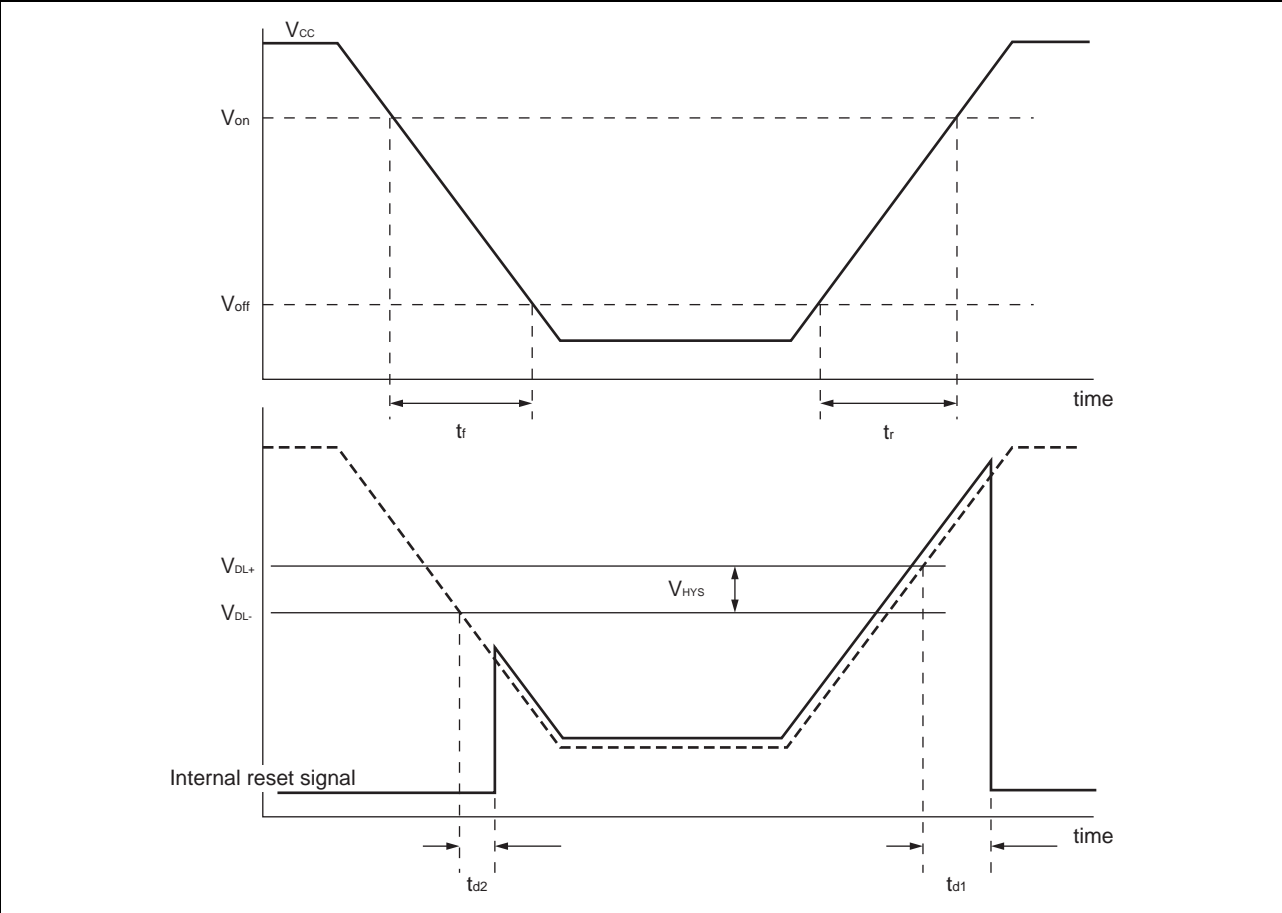

(7) I²C Bus Interface Timing

(V_{CC} = 5.0 V±10%, V_{SS} = 0.0 V, T_A = -40 °C to +85 °C)

Parameter	Symbol	Pin name	Condition	Value				Unit
				Standard-mode		Fast-mode		
				Min	Max	Min	Max	
SCL clock frequency	f _{SCL}	SCL		0	100	0	400	kHz
(Repeated) START condition hold time SDA ↓ → SCL ↓	t _{HD;STA}	SCL, SDA	R = 1.7 kΩ, C = 50 pF*1	4.0	—	0.6	—	μs
SCL clock "L" width	t _{LOW}	SCL		4.7	—	1.3	—	μs
SCL clock "H" width	t _{HIGH}	SCL		4.0	—	0.6	—	μs
(Repeated) START condition setup time SCL ↑ → SDA ↓	t _{SU;STA}	SCL, SDA		4.7	—	0.6	—	μs
Data hold time SCL ↓ → SDA ↓↑	t _{HD;DAT}	SCL, SDA		0	3.45*2	0	0.9*3	μs
Data setup time SDA ↓↑ → SCL ↑	t _{SU;DAT}	SCL, SDA		0.25	—	0.1	—	μs
STOP condition setup time SCL ↑ → SDA ↑	t _{SU;STO}	SCL, SDA		4	—	0.6	—	μs
Bus free time between STOP condition and START condition	t _{BUF}	SCL, SDA		4.7	—	1.3	—	μs

*1: R represents the pull-up resistor of the SCL and SDA lines, and C the load capacitor of the SCL and SDA lines.

*2: The maximum t_{HD;DAT} in the Standard-mode is applicable only when the time during which the device is holding the SCL signal at "L" (t_{LOW}) does not extend.

*3: A Fast-mode I²C-bus device can be used in a Standard-mode I²C-bus system, provided that the condition of t_{SU;DAT} ≥ 250 ns is fulfilled.

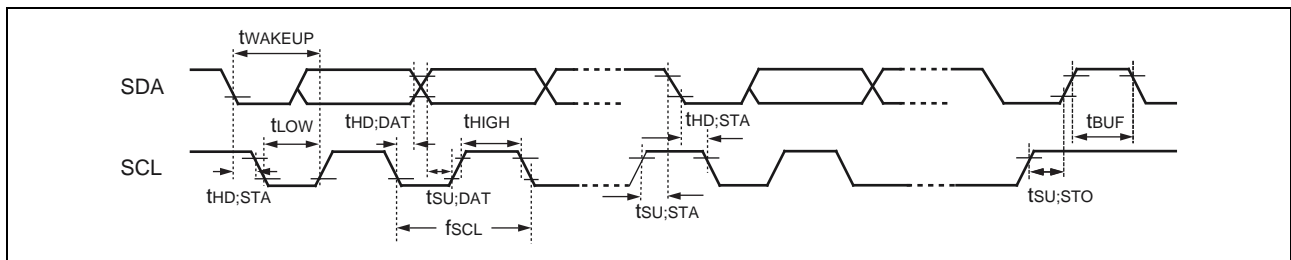

(Continued)

(V_{CC} = 5.0 V±10%, V_{SS} = 0.0 V, T_A = -40 °C to +85 °C)

Parameter	Symbol	Pin name	Condition	Value*2		Unit	Remarks
				Min	Max		
SCL clock "L" width	t _{LOW}	SCL	R = 1.7 kΩ, C = 50 pF*1	$(2 + nm/2)t_{MCLK} - 20$	—	ns	Master mode
SCL clock "H" width	t _{HIGH}	SCL		$(nm/2)t_{MCLK} - 20$	$(nm/2)t_{MCLK} + 20$	ns	Master mode
START condition hold time	t _{HD;STA}	SCL, SDA		$(-1 + nm/2)t_{MCLK} - 20$	$(-1 + nm)t_{MCLK} + 20$	ns	Master mode Maximum value is applied when m, n = 1, 8. Otherwise, the minimum value is applied.
STOP condition setup time	t _{SU;STO}	SCL, SDA		$(1 + nm/2)t_{MCLK} - 20$	$(1 + nm/2)t_{MCLK} + 20$	ns	Master mode
START condition setup time	t _{SU;STA}	SCL, SDA		$(1 + nm/2)t_{MCLK} - 20$	$(1 + nm/2)t_{MCLK} + 20$	ns	Master mode
Bus free time between STOP condition and START condition	t _{BUF}	SCL, SDA		$(2nm + 4)t_{MCLK} - 20$	—	ns	
Data hold time	t _{HD;DAT}	SCL, SDA		$3t_{MCLK} - 20$	—	ns	Master mode
Data setup time	t _{SU;DAT}	SCL, SDA		$(-2 + nm/2)t_{MCLK} - 20$	$(-1 + nm/2)t_{MCLK} + 20$	ns	Master mode It is assumed that "L" of SCL is not extended. The minimum value is applied to the first bit of continuous data. Otherwise, the maximum value is applied.
Setup time between clearing interrupt and SCL rising	t _{SU;INT}	SCL		$(nm/2)t_{MCLK} - 20$	$(1 + nm/2)t_{MCLK} + 20$	ns	The minimum value is applied to the interrupt at the ninth SCL↓. The maximum value is applied to the interrupt at the eighth SCL↓.
SCL clock "L" width	t _{LOW}	SCL		$4t_{MCLK} - 20$	—	ns	At reception
SCL clock "H" width	t _{HIGH}	SCL	$4t_{MCLK} - 20$	—	ns	At reception	

(Continued)

(Continued)

($V_{CC} = 5.0 V \pm 10\%$, $V_{SS} = 0.0 V$, $T_A = -40\text{ }^\circ\text{C}$ to $+85\text{ }^\circ\text{C}$)

Parameter	Symbol	Pin name	Condition	Value*2		Unit	Remarks
				Min	Max		
START condition detection	$t_{HD;STA}$	SCL, SDA	R = 1.7 k Ω , C = 50 pF*1	$2 t_{MCLK} - 20$	—	ns	No START condition is detected when 1 t_{MCLK} is used at reception.
STOP condition detection	$t_{SU;STO}$	SCL, SDA		$2 t_{MCLK} - 20$	—	ns	No STOP condition is detected when 1 t_{MCLK} is used at reception.
RESTART condition detection	$t_{SU;STA}$	SCL, SDA		$2 t_{MCLK} - 20$	—	ns	No RESTART condition is detected when 1 t_{MCLK} is used at reception.
Bus free time	t_{BUF}	SCL, SDA		$2 t_{MCLK} - 20$	—	ns	At reception
Data hold time	$t_{HD;DAT}$	SCL, SDA		$2 t_{MCLK} - 20$	—	ns	At slave transmission mode
Data setup time	$t_{SU;DAT}$	SCL, SDA		$t_{LOW} - 3 t_{MCLK} - 20$	—	ns	At slave transmission mode
Data hold time	$t_{HD;DAT}$	SCL, SDA		0	—	ns	At reception
Data setup time	$t_{SU;DAT}$	SCL, SDA		$t_{MCLK} - 20$	—	ns	At reception
SDA \downarrow → SCL \uparrow (with wakeup function in use)	t_{WAKEUP}	SCL, SDA		Oscillation stabilization wait time $+2 t_{MCLK} - 20$	—	ns	

*1: R represents the pull-up resistor of the SCL and SDA lines, and C the load capacitor of the SCL and SDA lines.

*2: • See “(2) Source Clock/Machine Clock” for t_{MCLK} .

- m represents the CS[4:3] bits in the I²C clock control register (ICCR0).
- n represents the CS[2:0] bits in the I²C clock control register (ICCR0).
- The actual timing of the I²C bus interface is determined by the values of m and n set by the machine clock (t_{MCLK}) and the CS[4:0] bits in the ICCR0 register.
- Standard-mode:
m and n can be set to values in the following range: $0.9\text{ MHz} < t_{MCLK}$ (machine clock) $< 16.25\text{ MHz}$.
The usable frequencies of the machine clock are determined by the settings of m and n as shown below.

(m, n) = (1, 8)	: $0.9\text{ MHz} < t_{MCLK} \leq 1\text{ MHz}$
(m, n) = (1, 22), (5, 4), (6, 4), (7, 4), (8, 4)	: $0.9\text{ MHz} < t_{MCLK} \leq 2\text{ MHz}$
(m, n) = (1, 38), (5, 8), (6, 8), (7, 8), (8, 8)	: $0.9\text{ MHz} < t_{MCLK} \leq 4\text{ MHz}$
(m, n) = (1, 98), (5, 22), (6, 22), (7, 22)	: $0.9\text{ MHz} < t_{MCLK} \leq 10\text{ MHz}$
(m, n) = (8, 22)	: $0.9\text{ MHz} < t_{MCLK} \leq 16.25\text{ MHz}$
- Fast-mode:
m and n can be set to values in the following range: $3.3\text{ MHz} < t_{MCLK}$ (machine clock) $< 16.25\text{ MHz}$.
The usable frequencies of the machine clock are determined by the settings of m and n as shown below.

(m, n) = (1, 8)	: $3.3\text{ MHz} < t_{MCLK} \leq 4\text{ MHz}$
(m, n) = (1, 22), (5, 4)	: $3.3\text{ MHz} < t_{MCLK} \leq 8\text{ MHz}$
(m, n) = (1, 38), (6, 4), (7, 4), (8, 4)	: $3.3\text{ MHz} < t_{MCLK} \leq 10\text{ MHz}$
(m, n) = (5, 8)	: $3.3\text{ MHz} < t_{MCLK} \leq 16.25\text{ MHz}$

(8) UART/SIO, Serial I/O Timing

($V_{CC} = 5.0 V \pm 10\%$, $V_{SS} = 0.0 V$, $T_A = -40\text{ }^\circ\text{C}$ to $+85\text{ }^\circ\text{C}$)

Parameter	Symbol	Pin name	Condition	Value		Unit
				Min	Max	
Serial clock cycle time	t_{SCYC}	UCK0, UCK1	Internal clock operation: $C_L = 80\text{ pF} + 1\text{ TTL}$	$4 t_{MCLK}^*$	—	ns
UCK ↓ → UO time	t_{SLOV}	UCK0, UCK1, UO0, UO1		-190	+190	ns
Valid UI → UCK ↑	t_{IVSH}	UCK0, UCK1, UI0, UI1		$2 t_{MCLK}^*$	—	ns
UCK ↑ → valid UI hold time	t_{SHIX}	UCK0, UCK1, UI0, UI1		$2 t_{MCLK}^*$	—	ns
Serial clock "H" pulse width	t_{SHSL}	UCK0, UCK1	External clock operation: $C_L = 80\text{ pF} + 1\text{ TTL}$	$4 t_{MCLK}^*$	—	ns
Serial clock "L" pulse width	t_{SLSH}	UCK0, UCK1		$4 t_{MCLK}^*$	—	ns
UCK ↓ → UO time	t_{SLOV}	UCK0, UCK1, UO0, UO1		—	190	ns
Valid UI → UCK ↑	t_{IVSH}	UCK0, UCK1, UI0, UI1		$2 t_{MCLK}^*$	—	ns
UCK ↑ → valid UI hold time	t_{SHIX}	UCK0, UCK1, UI0, UI1		$2 t_{MCLK}^*$	—	ns

*: See "(2) Source Clock/Machine Clock" for t_{MCLK} .

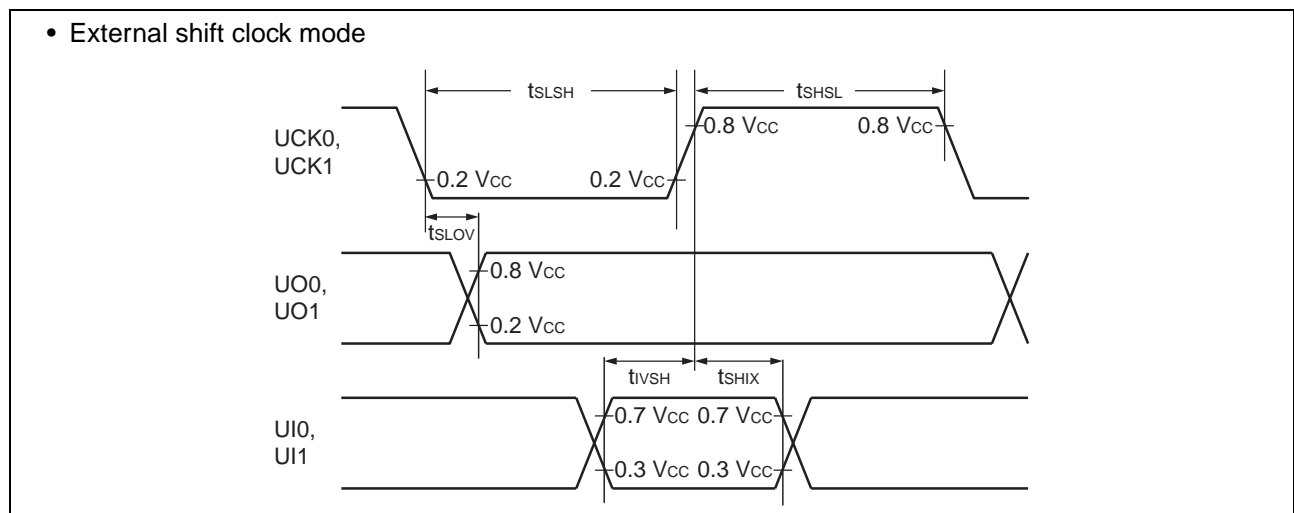
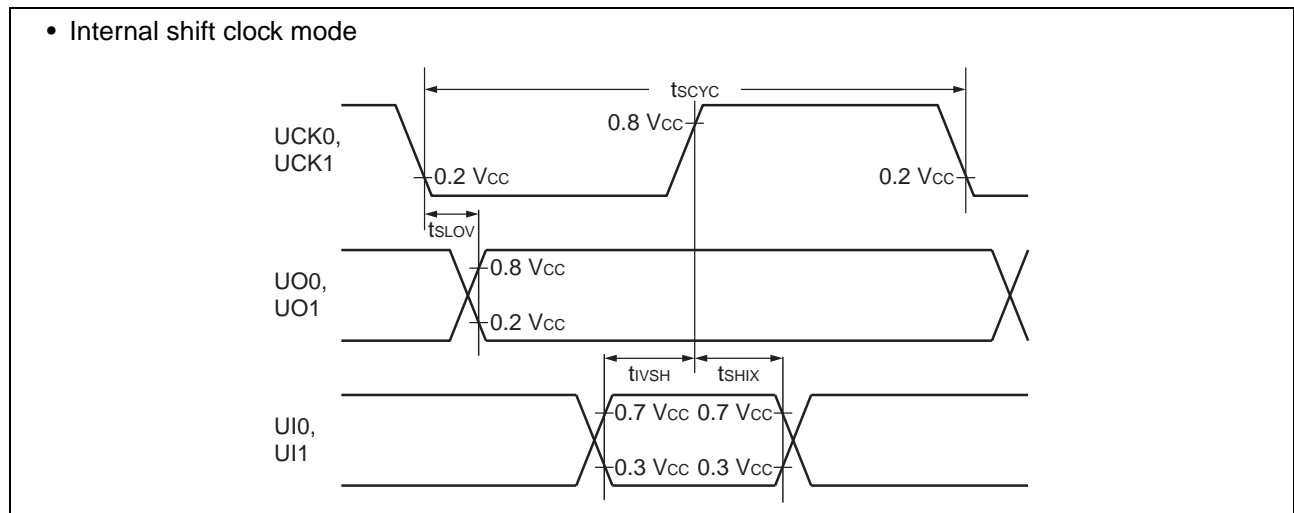

5. A/D Converter

(1) A/D Converter Electrical Characteristics

($V_{CC} = 2.7\text{ V to }5.5\text{ V}$, $V_{SS} = 0.0\text{ V}$, $T_A = -40\text{ }^\circ\text{C to }+85\text{ }^\circ\text{C}$)

Parameter	Symbol	Value			Unit	Remarks
		Min	Typ	Max		
Resolution	—	—	—	10	bit	
Total error		-3	—	+3	LSB	
Linearity error		-2.5	—	+2.5	LSB	
Differential linearity error		-1.9	—	+1.9	LSB	
Zero transition voltage	V_{0T}	$V_{SS} - 7.2\text{ LSB}$	$V_{SS} + 0.5\text{ LSB}$	$V_{SS} + 8.2\text{ LSB}$	V	
Full-scale transition voltage	V_{FST}	$V_{CC} - 6.2\text{ LSB}$	$V_{CC} - 1.5\text{ LSB}$	$V_{CC} + 9.2\text{ LSB}$	V	
Compare time	—	3	—	10	μs	$2.7\text{ V} \leq V_{CC} \leq 5.5\text{ V}$
Sampling time	—	0.941	—	∞	μs	$2.7\text{ V} \leq V_{CC} \leq 5.5\text{ V}$, with external impedance $< 3.3\text{ k}\Omega$ and external capacitance = 10 pF
Analog input current	I_{AIN}	-0.3	—	+0.3	μA	
Analog input voltage	V_{AIN}	V_{SS}	—	V_{CC}	V	

(2) Notes on Using A/D Converter

• External impedance of analog input and its sampling time

The A/D converter has a sample and hold circuit. If the external impedance is too high to keep sufficient sampling time, the analog voltage charged to the capacitor of the internal sample and hold circuit is insufficient, adversely affecting A/D conversion precision. Therefore, to satisfy the A/D conversion precision standard, considering the relationship between the external impedance and minimum sampling time, either adjust the register value and operating frequency or decrease the external impedance so that the sampling time is longer than the minimum value. In addition, if sufficient sampling time cannot be secured, connect a capacitor of about 0.1 μF to the analog input pin.

• Analog input equivalent circuit

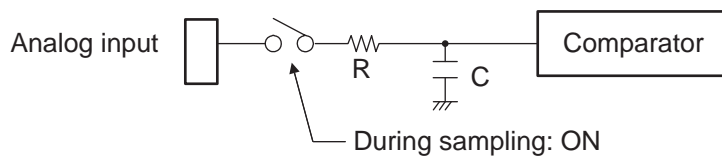

V _{CC}	R	C
4.5 V ≤ V _{CC} ≤ 5.5 V	1.45 kΩ (Max)	14.89 pF (Max)
2.7 V ≤ V _{CC} < 4.5 V	2.7 kΩ (Max)	14.89 pF (Max)

Note: The values are reference values.

• Relationship between external impedance and minimum sampling time

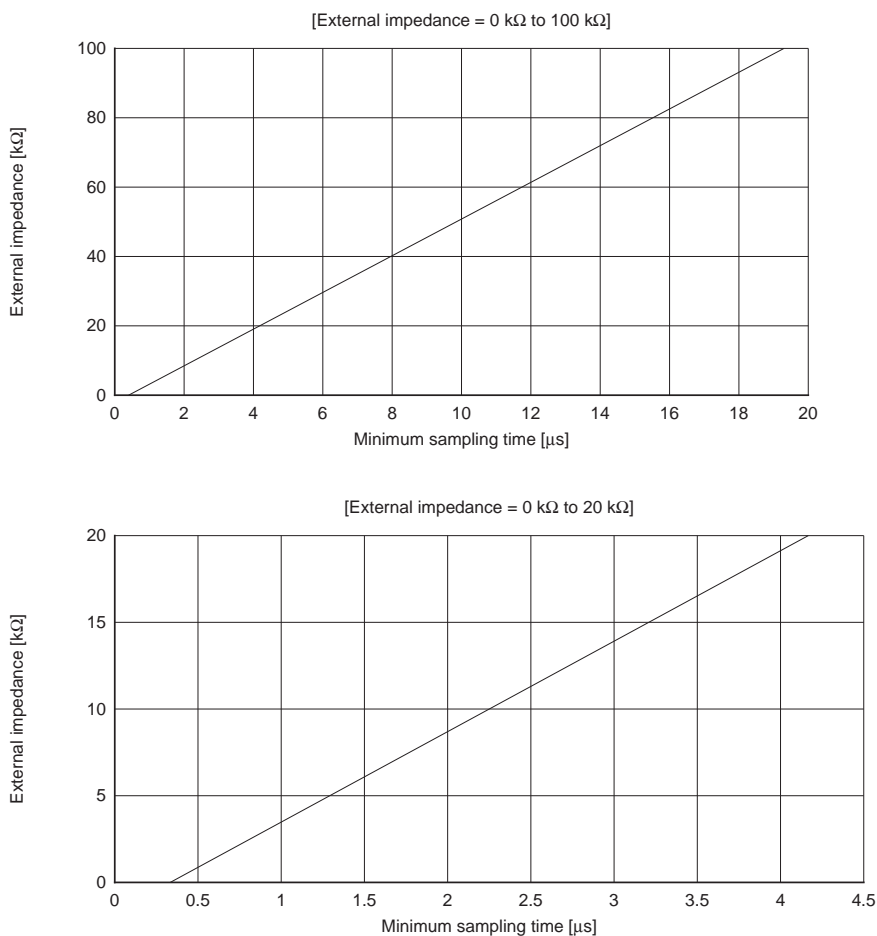

Note: External capacitance = 10 pF

• A/D conversion error

As |V_{CC} – V_{SS}| decreases, the A/D conversion error increases proportionately.

(3) Definitions of A/D Converter Terms

- Resolution
It indicates the level of analog variation that can be distinguished by the A/D converter.
When the number of bits is 10, analog voltage can be divided into $2^{10} = 1024$.
- Linearity error (unit: LSB)
It indicates how much an actual conversion value deviates from the straight line connecting the zero transition point (“0000000000” ← → “0000000001”) of a device to the full-scale transition point (“1111111111” ← → “1111111110”) of the same device.
- Differential linear error (unit: LSB)
It indicates how much the input voltage required to change the output code by 1 LSB deviates from an ideal value.
- Total error (unit: LSB)
It indicates the difference between an actual value and a theoretical value. The error can be caused by a zero transition error, a full-scale transition errors, a linearity error, a quantum error, or noise.

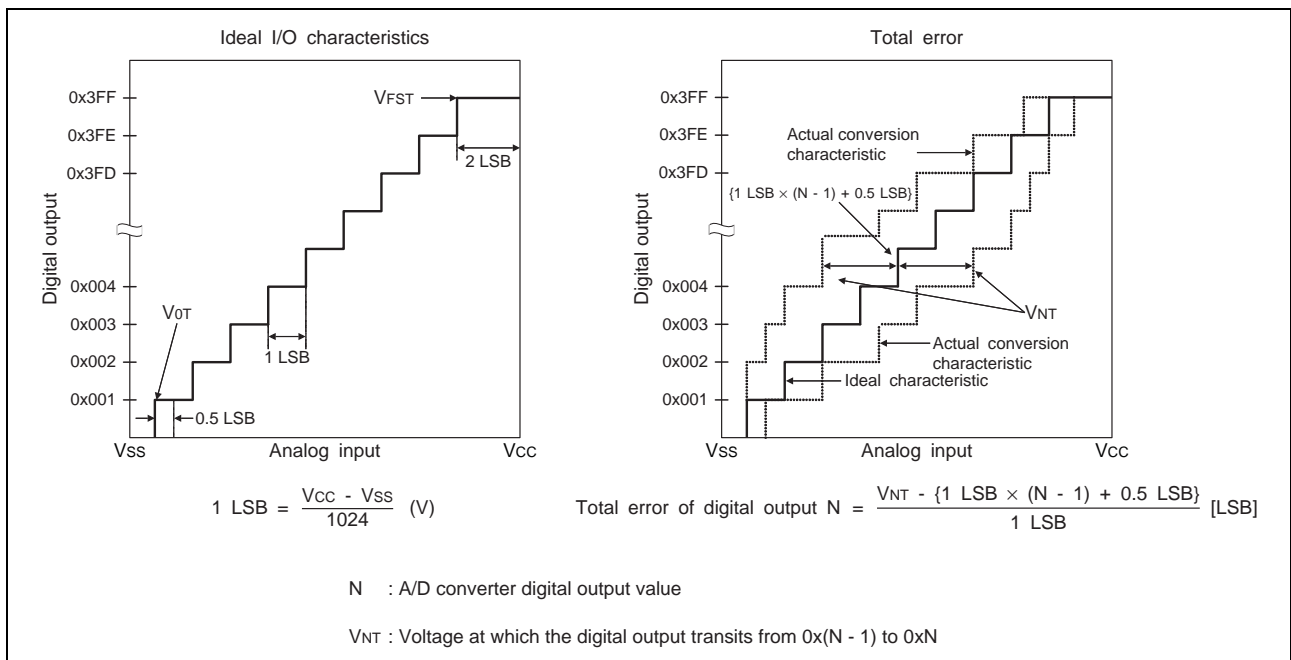

(Continued)

(Continued)

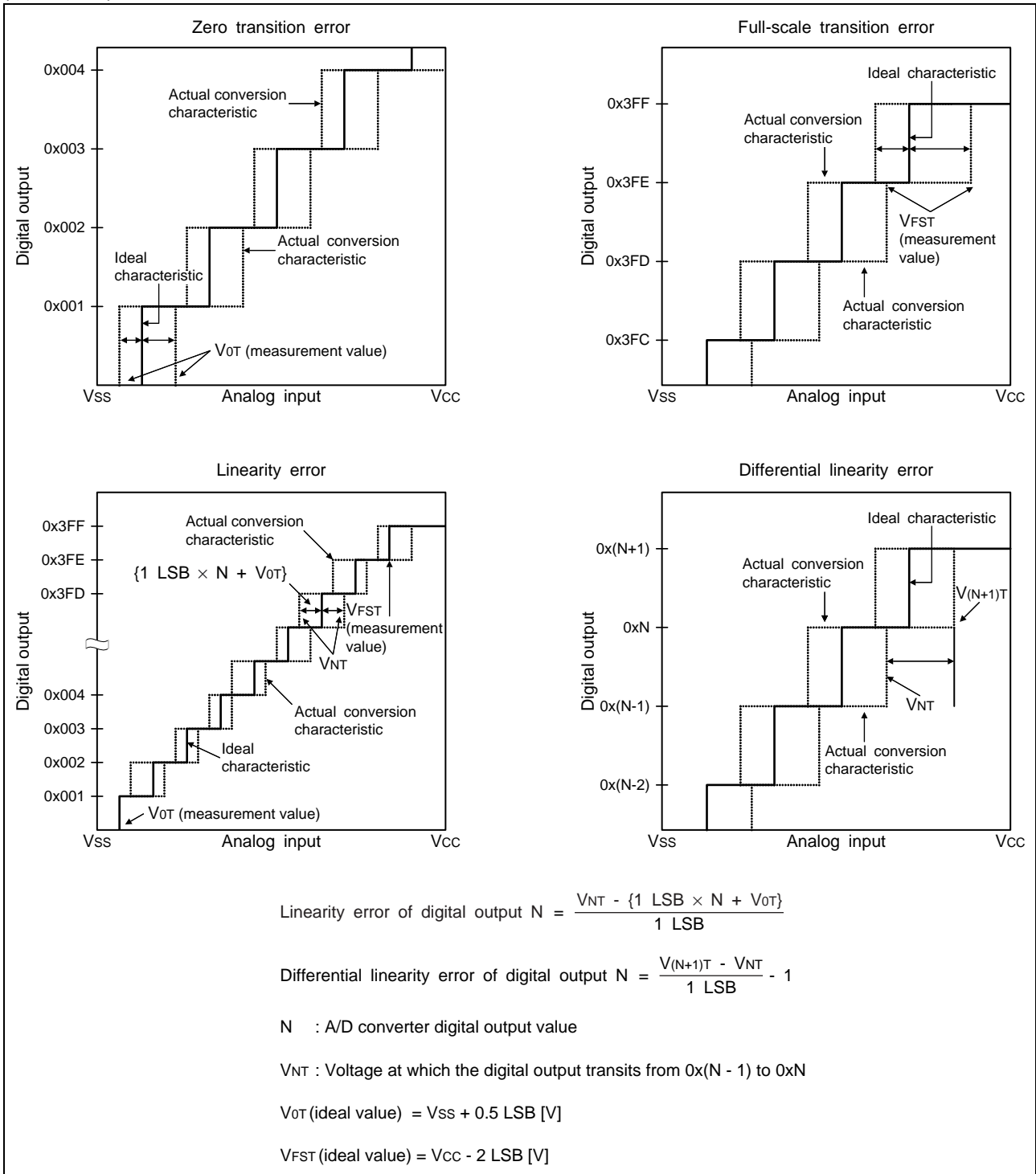

6. Flash Memory Program/Erase Characteristics

Parameter	Value			Unit	Remarks
	Min	Typ	Max		
Sector erase time (2 Kbyte sector)	—	0.3* ¹	1.6* ²	s	The time of writing "0x00" prior to erasure is excluded.
Sector erase time (32 Kbyte sector)	—	0.6* ¹	3.1* ²	s	The time of writing "0x00" prior to erasure is excluded.
Byte writing time	—	17	272	μs	System-level overhead is excluded.
Program/erase cycle	100000	—	—	cycle	
Power supply voltage at program/erase	2.4	—	5.5	V	
Flash memory data retention time	20* ³	—	—	year	Average T _A = +85 °C Number of program/erase cycles: 1000 or below
	10* ³	—	—		Average T _A = +85 °C Number of program/erase cycles: 1001 to 10000 inclusive
	5* ³	—	—		Average T _A = +85 °C Number of program/erase cycles: 10001 or above

*1: V_{CC} = 5.5 V, T_A = +25 °C, 0 cycle

*2: V_{CC} = 2.4 V, T_A = +85 °C, 100000 cycles

*3: These values were converted from the result of a technology reliability assessment. (These values were converted from the result of a high temperature accelerated test using the Arrhenius equation with the average temperature being +85 °C.)

■ MASK OPTIONS

No.	Part number	MB95F613H MB95F614H MB95F616H	MB95F613K MB95F614K MB95F616K
	Selectable/Fixed	Fixed	
1	Low-voltage detection reset	Without low-voltage detection reset	With low-voltage detection reset
2	Reset	With dedicated reset input	Without dedicated reset input

■ ORDERING INFORMATION

Part number	Package
MB95F613HPMC-G-SNE2 MB95F613KPMC-G-SNE2 MB95F614HPMC-G-SNE2 MB95F614KPMC-G-SNE2 MB95F616HPMC-G-SNE2 MB95F616KPMC-G-SNE2	80-pin plastic LQFP (FPT-80P-M37)

■ PACKAGE DIMENSION

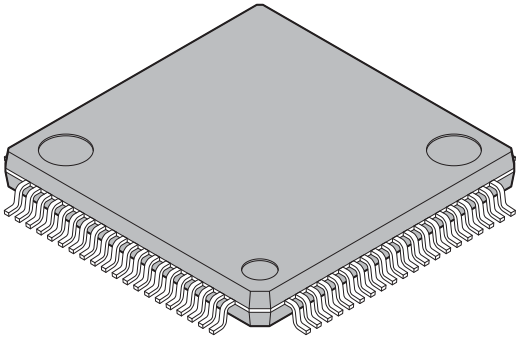
<p>80-pin plastic LQFP</p>  <p>(FPT-80P-M37)</p>	Lead pitch	0.50 mm
	Package width × package length	12.00 mm × 12.00 mm
	Lead shape	Gullwing
	Lead bend direction	Normal bend
	Sealing method	Plastic mold
	Mounting height	1.70 mm MAX
	Weight	0.47 g

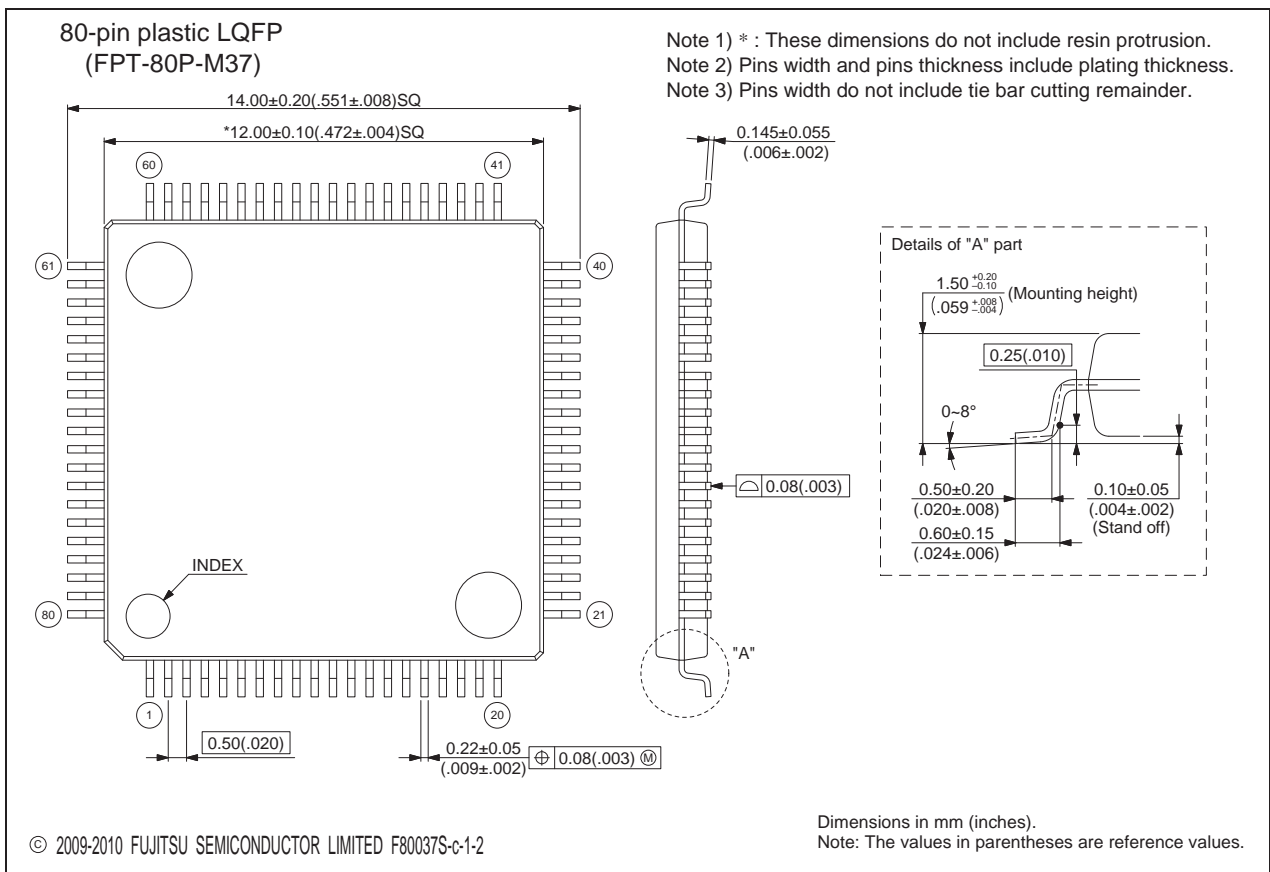

Please check the latest package dimension at the following URL.
<http://edevice.fujitsu.com/package/en-search/>

FUJITSU SEMICONDUCTOR LIMITED

Nomura Fudosan Shin-yokohama Bldg. 10-23, Shin-yokohama 2-Chome,
Kohoku-ku Yokohama Kanagawa 222-0033, Japan
Tel: +81-45-415-5858
<http://jp.fujitsu.com/fsl/en/>

For further information please contact:

North and South America

FUJITSU SEMICONDUCTOR AMERICA, INC.
1250 E. Arques Avenue, M/S 333
Sunnyvale, CA 94085-5401, U.S.A.
Tel: +1-408-737-5600 Fax: +1-408-737-5999
<http://us.fujitsu.com/micro/>

Europe

FUJITSU SEMICONDUCTOR EUROPE GmbH
Pittlerstrasse 47, 63225 Langen, Germany
Tel: +49-6103-690-0 Fax: +49-6103-690-122
<http://emea.fujitsu.com/semiconductor/>

Korea

FUJITSU SEMICONDUCTOR KOREA LTD.
902 Kosmo Tower Building, 1002 Daechi-Dong,
Gangnam-Gu, Seoul 135-280, Republic of Korea
Tel: +82-2-3484-7100 Fax: +82-2-3484-7111
<http://kr.fujitsu.com/fsk/>

Asia Pacific

FUJITSU SEMICONDUCTOR ASIA PTE. LTD.
151 Lorong Chuan,
#05-08 New Tech Park 556741 Singapore
Tel : +65-6281-0770 Fax : +65-6281-0220
<http://sg.fujitsu.com/semiconductor/>

FUJITSU SEMICONDUCTOR SHANGHAI CO., LTD.

30F, Kerry Parkside, 1155 Fang Dian Road, Pudong District,
Shanghai 201204, China
Tel : +86-21-6146-3688 Fax : +86-21-6146-3660
<http://cn.fujitsu.com/fss/>

FUJITSU SEMICONDUCTOR PACIFIC ASIA LTD.

2/F, Green 18 Building, Hong Kong Science Park,
Shatin, N.T., Hong Kong
Tel : +852-2736-3232 Fax : +852-2314-4207
<http://cn.fujitsu.com/fsp/>

Specifications are subject to change without notice. For further information please contact each office.

All Rights Reserved.

The contents of this document are subject to change without notice.

Customers are advised to consult with sales representatives before ordering.

The information, such as descriptions of function and application circuit examples, in this document are presented solely for the purpose of reference to show examples of operations and uses of FUJITSU SEMICONDUCTOR device; FUJITSU SEMICONDUCTOR does not warrant proper operation of the device with respect to use based on such information. When you develop equipment incorporating the device based on such information, you must assume any responsibility arising out of such use of the information.

FUJITSU SEMICONDUCTOR assumes no liability for any damages whatsoever arising out of the use of the information.

Any information in this document, including descriptions of function and schematic diagrams, shall not be construed as license of the use or exercise of any intellectual property right, such as patent right or copyright, or any other right of FUJITSU SEMICONDUCTOR or any third party or does FUJITSU SEMICONDUCTOR warrant non-infringement of any third-party's intellectual property right or other right by using such information. FUJITSU SEMICONDUCTOR assumes no liability for any infringement of the intellectual property rights or other rights of third parties which would result from the use of information contained herein.

The products described in this document are designed, developed and manufactured as contemplated for general use, including without limitation, ordinary industrial use, general office use, personal use, and household use, but are not designed, developed and manufactured as contemplated (1) for use accompanying fatal risks or dangers that, unless extremely high safety is secured, could have a serious effect to the public, and could lead directly to death, personal injury, severe physical damage or other loss (i.e., nuclear reaction control in nuclear facility, aircraft flight control, air traffic control, mass transport control, medical life support system, missile launch control in weapon system), or (2) for use requiring extremely high reliability (i.e., submersible repeater and artificial satellite).

Please note that FUJITSU SEMICONDUCTOR will not be liable against you and/or any third party for any claims or damages arising in connection with above-mentioned uses of the products.

Any semiconductor devices have an inherent chance of failure. You must protect against injury, damage or loss from such failures by incorporating safety design measures into your facility and equipment such as redundancy, fire protection, and prevention of over-current levels and other abnormal operating conditions.

Exportation/release of any products described in this document may require necessary procedures in accordance with the regulations of the Foreign Exchange and Foreign Trade Control Law of Japan and/or US export control laws.

The company names and brand names herein are the trademarks or registered trademarks of their respective owners.

Edited: Sales Promotion Department