

# 32-bit Microcontroller

CMOS

## FR60 Lite MB91345 Series

### MB91F345B/F346B

#### ■ DESCRIPTION

The MB91345 series is the microcontrollers based on 32-bit high-perform RISC-CPU while integrating a variety of I/O resources for embedded control applications which require high-performance, high-speed CPU processing.

It is suitable for the embedded control in digital home appliances or audio visual equipment, requiring high-performance CPU processing power.

This product compactly integrates a variety of peripheral functions for single chip and is FR60\* applicable to faster-speed application.

\* : FR is the abbreviation of FUJITSU RISC controller.

#### ■ FEATURE

- FR CPU
  - 32-bit RISC, load/store architecture, with a five-stage pipeline
  - Maximum operating frequency : 50 MHz [PLL used : original oscillation 12.5 MHz]
  - 16-bit fixed length instruction (basic instructions) ; 1 instruction per cycle
  - Instruction set optimized for embedded applications : Memory-to-Memory transfer, bit manipulation, barrel shift instructions
  - Instructions adapted for high-level programming languages : Function entry/exit instructions, multiple-register load/store instructions
  - Register interlock function : Facilitating coding in assembles

*(Continued)*

Be sure to refer to the "Check Sheet" for the latest cautions on development.

"Check Sheet" is seen at the following support page  
URL : <http://edevic.fujitsu.com/micom/en-support/>

"Check Sheet" lists the minimal requirement items to be checked to prevent problems beforehand in system development.

# MB91345 Series

- On-chip multiplier supported at instruction level
  - Signed 32-bit multiplication : 5 cycles
  - Signed 16-bit multiplication : 3 cycles
- Interrupt (PC, PS save) : 6 cycles, 16 priority levels
- Harvard architecture allowing program access and data access to be executed simultaneously
- Instruction set compatible with FR family

- Internal memory

	Flash	D-bus RAM	F-bus RAM
MB91F345B	512 Kbytes	24 Kbytes	8 Kbytes
MB91F346B	1 Mbyte	24 Kbytes	8 Kbytes

- DMAC (DMA Controller)

- 5 channels
- Two transfer factors (internal peripheral / software)
- Addressing mode : 20/24-bit full-address selection (increment/decrement/fixed)
- Transfer modes (burst transfer/step transfer/and block transfer)
- Selectable transfer data sizes : 8, 16, or 32 bits

- Bit search module (for REALOS)

Search for the position of the bit I/O-changed first in one word from the MSB

- Reload timer : 3 channels (including 1channel for REALOS)

- 16-bit timer
- The internal clock is optional from 2/8/32 division

- Multi function serial interface

- 11 channels
- Full duplex double buffer
- 2 channels out of 11 channels with 16-byte FIFO
- Capable of selecting communication mode : asynchronous (Start-Stop synchronous) communication, clock synchronous communication (Max 8.25 Mbps) , I<sup>2</sup>C\* standard mode (Max 100 kbps) , high-speed mode (Max 400 kbps)
- Parity on/off selectable
- Baud rate generator per channel
- Abundant error detection functions are provided (Parity, frame, and overrun)
- External clock can be used as transfer clock
- ch.0, ch.1, ch.2, and ch.10 is tolerant of 5 V

- Interrupt controller

- A total of 24 external interrupt lines (external interrupt pins INT23 to INT0)
- Interrupt from internal peripheral
- Programmable 16 priority levels
- Available for wakeup from STOP mode

(Continued)

(Continued)

- A/D converter :
  - 10-bit resolution, 8 channels + 8 channels 2 unit
  - Successive approximation type : Conversion time : min. 1.2  $\mu$ s (at 16 MHz)
  - Conversion mode (Shingle-shot conversion mode, scan conversion mode)
  - Startup source (software/external trigger)
- PPG timer : up to 16 channels (at 8 bits)
  - 8/16-bit PPG timer : 8 bits  $\times$  16 channels or 16 bits  $\times$  8 channels
  - The internal clock is optional from 1/4/16/64 division
- PWC timer : 1 channel  
16-bit up counter 1 channel (1 input)
- Input capture and output compare : up to 8 channels (ch.0 to ch.3; 16-bit ICU, OCU, ch.4 to ch.7; 32-bit ICU, OCU)
  - 16-bit free-run timer  $\times$  1 channel + 16-bit input capture  $\times$  4 channels + 16-bit output compare  $\times$  4 channels
  - 32-bit free-run timer  $\times$  1 channel + 32-bit input capture  $\times$  4 channels + 32-bit output compare  $\times$  4 channels
- MIN/MAX/ABS
  - MIN/MAX/ABS is performed and the result is accumulated and added.
- Other interval timer and counter
  - 8/16-bit up down counter :  
8-bit  $\times$  4 channels or 16-bit  $\times$  2 channels
  - 16-bit timebase timer/watchdog timer
- I/O port
  - Max 71 ports
- Other features
  - Internal oscillation circuit as a clock source and PLL multiplier
  - $\overline{\text{INIT}}$  is prepared as a reset terminal
  - Watchdog timer reset and software reset are also available
  - Stop and sleep mode supported as low-power-consumption modes
  - Gear function
  - Built-in time base timer
  - Memory patch function
  - Package : TQFP-100
  - CMOS technology (0.18  $\mu$ m)
  - Power supply voltage : 3.3 V  $\pm$  0.3 V (single power supply)

\* : Purchase of Fujitsu I<sup>2</sup>C components conveys a license under the Philips I<sup>2</sup>C Patent Rights to use, these components in an I<sup>2</sup>C system provided that the system conforms to the I<sup>2</sup>C Standard Specification as defined by Philips.

# MB91345 Series

## ■ PIN ASSIGNMENT

(TOP VIEW)

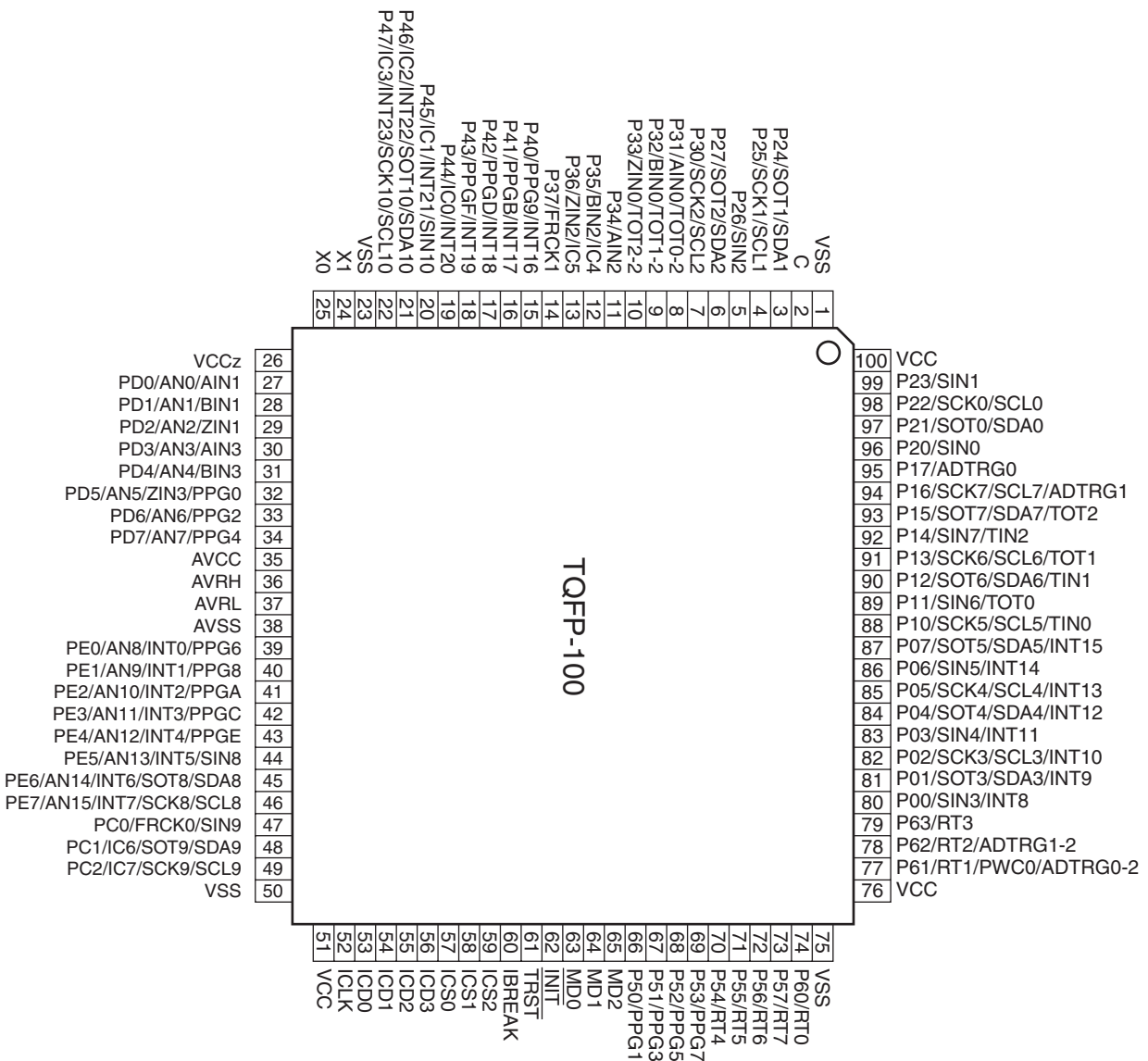

(FPT-100P-M18)

Note : TOTx and TOTx-2 have same function. Also ADTRGx and ADTRGx-2 have same function. Use either of the two depending on the combined resource.

## ■ PIN DESCRIPTION

Pin No.	Pin name	I/O Circuit type*	Function
1	VSS	—	GND pin
2	C	—	Power stabilization capacitance pin
3	P24	B	General-purpose I/O port
	SOT1/ SDA1		Multi function serial 1 serial data output pins I <sup>2</sup> C data I/O pins
4	P25	B	General-purpose I/O port. Enabled in single-chip mode.
	SCK1/ SCL1		Multi function serial 1 clock I/O pins I <sup>2</sup> C clock I/O pins
5	P26	B	General-purpose I/O port. Enabled in single-chip mode.
	SIN2		Multi function serial 2 serial data input pin
6	P27	B	General-purpose I/O port. Enabled in single-chip mode.
	SOT2/ SDA2		Multi function serial 2 serial data output pins I <sup>2</sup> C data I/O pins
7	P30	B	General-purpose I/O port. Enabled in single-chip mode.
	SCK2/ SCL2		Multi function serial 2 clock I/O pins I <sup>2</sup> C clock I/O pins
8	P31	B	General-purpose I/O port. Enabled in single-chip mode.
	AIN0		Up down counter input pin
	TOT0-2		Reload timer output pin
9	P32	B	General-purpose I/O port. Enabled in single-chip mode.
	BIN0		Up down counter input pin
	TOT1-2		Reload timer output pin
10	P33	B	General-purpose I/O port. Enabled in single-chip mode.
	ZIN0		Up down counter input pin
	TOT2-2		Reload timer output pin
11	P34	B	General-purpose I/O port. Enabled in single-chip mode.
	AIN2		Up down counter input pin
12	P35	B	General-purpose I/O port. Enabled in single-chip mode.
	BIN2		Up down counter input pin
	IC4		Input capture ICU 4 data sample input pin
13	P36	B	General-purpose I/O port. Enabled in single-chip mode.
	ZIN2		Up down counter input pin
	IC5		Input capture ICU 5 data sample input pin
14	P37	B	General-purpose I/O port. Enabled in single-chip mode.
	FRCK1		32-bit free-run timer input pin

(Continued)

# MB91345 Series

Pin No.	Pin name	I/O Circuit type*	Function
15	P40	B	General-purpose I/O port
	PPG9		PPG output pin
	INT16		External interrupt request 16 input pin
16	P41	B	General-purpose I/O port
	PPGB		PPG output pin
	INT17		External interrupt request 17 input pin
17	P42	B	General-purpose I/O port
	PPGD		PPG output pin
	INT18		External interrupt request 18 input pin
18	P43	B	General-purpose I/O port
	PPGF		PPG output pin
	INT19		External interrupt request 19 input pin
19	P44	B	General-purpose I/O port
	IC0		Input capture ICU0 data sample input pin
	INT20		External interrupt request 20 input pin
20	P45	B	General-purpose I/O port
	IC1		Input capture ICU1 data sample input pin
	INT21		External interrupt request 21 input pin
	SIN10		Multi function serial 10 serial data input pin
21	P46	B	General-purpose I/O port
	IC2		Input capture ICU2 data sample input pin
	INT22		External interrupt request 22 input pin
	SOT10/ SDA10		Multi function serial 10 serial data output pins I <sup>2</sup> C data I/O pins
22	P47	B	General-purpose I/O port
	IC3		Input capture ICU3 data sample input pin
	INT23		External interrupt request 23 input pin
	SCK10/ SCL10		Multi function serial 10 clock I/O pins I <sup>2</sup> C clock I/O pins
23	VSS	—	GND pin
24	X1	A	Main clock I/O pin
25	X0	A	Main clock input pin
26	VCC	—	Power supply input pin (3.3 V)

(Continued)

# MB91345 Series

Pin No.	Pin name	I/O Circuit type*	Function
27	PD0	E	General-purpose I/O port
	AN0		A/D converter analog input pin
	AIN1		Up down counter input pin
28	PD1	E	General-purpose I/O port
	AN1		A/D converter analog input pin
	BIN1		Up down counter input pin
29	PD2	E	General-purpose I/O port
	AN2		A/D converter analog input pin
	ZIN1		Up down counter input pin
30	PD3	E	General-purpose I/O port
	AN3		A/D converter analog input pin
	AIN3		Up down counter input pin
31	PD4	E	General-purpose I/O port
	AN4		A/D converter analog input pin
	BIN3		Up down counter input pin
32	PD5	E	General-purpose I/O port
	AN5		A/D converter analog input pin
	ZIN3		Up down counter input pin
	PPG0		PPG output pin
33	PD6	E	General-purpose I/O port
	AN6		A/D converter analog input pin
	PPG2		PPG output pin
34	PD7	E	General-purpose I/O port
	AN7		A/D converter analog input pin
	PPG4		PPG output pin
35	AVCC	—	A/D converter analog power supply input pin
36	AVRH	—	A/D converter standard voltage input pin Be sure to turn on/off this power supply when potential of AVRH or more is applied to AVCC.
37	AVRL	—	A/D converter standard low voltage input pin
38	AVSS	—	A/D converter analog GND pin

(Continued)

# MB91345 Series

Pin No.	Pin name	I/O Circuit type*	Function
39	PE0	E	General-purpose I/O port
	AN8		A/D converter analog input pin
	INT0		External interrupt request 0 input pin
	PPG6		PPG output pin
40	PE1	E	General-purpose I/O port
	AN9		A/D converter analog input pin
	INT1		External interrupt request 1 input pin
	PPG8		PPG output pin
41	PE2	E	General-purpose I/O port
	AN10		A/D converter analog input pin
	INT2		External interrupt request 2 input pin
	PPGA		PPG output pin
42	PE3	E	General-purpose I/O port
	AN11		A/D converter analog input pin
	INT3		External interrupt request 3 input pin
	PPGC		PPG output pin
43	PE4	E	General-purpose I/O port
	AN12		A/D converter analog input pin
	INT4		External interrupt request 4 input pin
	PPGE		PPG output pin
44	PE5	E	General-purpose I/O port
	AN13		A/D converter analog input pin
	INT5		External interrupt request 5 input pin
	SIN8		Multi function serial 8 serial data input pin
45	PE6	E	General-purpose I/O port
	AN14		A/D converter analog input pin
	INT6		External interrupt request 6 input pin
	SOT8/ SDA8		Multi function serial 8 serial data output pins I <sup>2</sup> C data I/O pins
46	PE7	E	General-purpose I/O port
	AN15		A/D converter analog input pin
	INT7		External interrupt request 7 input pin
	SCK8/ SCL8		Multi function serial 8 clock I/O pins I <sup>2</sup> C clock I/O pins

(Continued)

# MB91345 Series

Pin No.	Pin name	I/O Circuit type*	Function
47	PC0	C	General-purpose I/O port
	FRCK0		16-bit free-run timer input pin
	SIN9		Multi function serial 9 serial data input pin
48	PC1	C	General-purpose I/O port
	IC6		Input capture ICU6 data sample input pin
	SOT9/ SDA9		Multi function serial 9 serial data output pins I <sup>2</sup> C data I/O pins
49	PC2	C	General-purpose I/O port
	IC7		Input capture ICU7 data sample input pin
	SCK9/ SCL9		Multi function serial 9 clock I/O pins I <sup>2</sup> C clock I/O pins
50	VSS	—	GND pin
51	VCC	—	Power supply input pin (3.3 V)
52	ICLK	H	Development tool clock pin
53	ICD0	K	Development tool data pin
54	ICD1	K	Development tool data pin
55	ICD2	K	Development tool data pin
56	ICD3	K	Development tool data pin
57	ICS0	J	Development tool status pin
58	ICS1	J	Development tool status pin
59	ICS2	J	Development tool status pin
60	IBREAK	I	Development tool break pin
61	$\overline{\text{TRST}}$	G	Development tool reset pin
62	$\overline{\text{INIT}}$	G	Initial reset pin
63	MD0	F	Mode input pin
64	MD1	F	Mode input pin
65	MD2	F	Mode input pin
66	P50	C	General-purpose I/O port
	PPG1		PPG output pin
67	P51	C	General-purpose I/O port
	PPG3		PPG output pin
68	P52	C	General-purpose I/O port
	PPG5		PPG output pin

(Continued)

# MB91345 Series

Pin No.	Pin name	I/O Circuit type*	Function
69	P53	C	General-purpose I/O port
	PPG7		PPG output pin
70	P54	C	General-purpose I/O port
	RT4		Output compare OCU4 waveform output pin
71	P55	C	General-purpose I/O port
	RT5		Output compare OCU5 waveform output pin
72	P56	D	General-purpose I/O port
	RT6		Output compare OCU6 waveform output pin
73	P57	D	General-purpose I/O port
	RT7		Output compare OCU7 waveform output pin
74	P60	C	General-purpose I/O port
	RT0		Output compare OCU0 waveform output pin
75	VSS	—	GND pin
76	VCC	—	Power supply input pin (3.3 V)
77	P61	C	General-purpose I/O port
	RT1		Output compare OCU1 waveform output pin
	PWC0		PWC input pin
	ADTRG0-2		A/D converter trigger input pin
78	P62	C	General-purpose I/O port
	RT2		Output compare OCU2 waveform output pin
	ADTRG1-2		A/D converter trigger input pin
79	P63	C	General-purpose I/O port
	RT3		Output compare OCU3 waveform output pin
80	P00	C	General-purpose I/O port
	SIN3		Multi function serial 3 serial data input pin
	INT8		External interrupt request 8 input pin
81	P01	C	General-purpose I/O port
	SOT3/ SDA3		Multi function serial 3 serial data output pins I <sup>2</sup> C data I/O pins
	INT9		External interrupt request 9 input pin
82	P02	C	General-purpose I/O port
	SCK3/ SCL3		Multi function serial 3 clock I/O pins I <sup>2</sup> C clock I/O pins
	INT10		External interrupt request 10 input pin

(Continued)

# MB91345 Series

Pin No.	Pin name	I/O Circuit type*	Function
83	P03	C	General-purpose I/O port
	SIN4		Multi function serial 4 serial data input pin
	INT11		External interrupt request 11 input pin
84	P04	C	General-purpose I/O port
	SOT4/ SDA4		Multi function serial 4 serial data output pins I <sup>2</sup> C data I/O pins
	INT12		External interrupt request 12 input pin
85	P05	C	General-purpose I/O port
	SCK4/ SCL4		Multi function serial 4 clock I/O pins I <sup>2</sup> C clock I/O pins
	INT13		External interrupt request 13 input pin
86	P06	C	General-purpose I/O port
	SIN5		Multi function serial 5 serial data input pin
	INT14		External interrupt request 14 input pin
87	P07	C	General-purpose I/O port
	SOT5/ SDA5		Multi function serial 5 serial data output pins I <sup>2</sup> C data I/O pins
	INT15		External interrupt request 15 input pin
88	P10	C	General-purpose I/O port
	SCK5/ SCL5		Multi function serial 5 clock I/O pins I <sup>2</sup> C clock I/O pins
	TIN0		Reload timer event input pin
89	P11	C	General-purpose I/O port
	SIN6		Multi function serial 6 serial data input pin
	TOT0		Reload timer output pin
90	P12	C	General-purpose I/O port
	SOT6/ SDA6		Multi function serial 6 serial data output pins I <sup>2</sup> C data I/O pins
	TIN1		Reload timer event input pin
91	P13	C	General-purpose I/O port
	SCK6/ SCL6		Multi function serial 6 clock I/O pins I <sup>2</sup> C clock I/O pins
	TOT1		Reload timer output pin
92	P14	C	General-purpose I/O port
	SIN7		Multi function serial 7 serial data input pin
	TIN2		Reload timer event input pin

(Continued)

# MB91345 Series

(Continued)

Pin No.	Pin name	I/O Circuit type*	Function
93	P15	C	General-purpose I/O port
	SOT7/ SDA7		Multi function serial 7 serial data output pins I <sup>2</sup> C data I/O pins
	TOT2		Reload timer output pin
94	P16	C	General-purpose I/O port
	SCK7/ SCL7		Multi function serial 7 clock I/O pins I <sup>2</sup> C clock I/O pins
	ADTRG1		A/D converter trigger input pin
95	P17	C	General-purpose I/O port
	ADTRG0		A/D converter trigger input pin
96	P20	C	General-purpose I/O port
	SIN0		Multi function serial 0 serial data input pin
97	P21	C	General-purpose I/O port
	SOT0/ SDA0		Multi function serial 0 serial data output pins I <sup>2</sup> C data I/O pins
98	P22	C	General-purpose I/O port
	SCK0/ SCL0		Multi function serial 0 clock I/O pins I <sup>2</sup> C clock I/O pins
99	P23	C	General-purpose I/O port
	SIN1		Multi function serial 1 serial data input pin
100	VCC	—	Power supply input pin (3.3 V)

\* : For the I/O circuit type, refer to “■ I/O CIRCUIT TYPE”.

## ■ I/O CIRCUIT TYPE

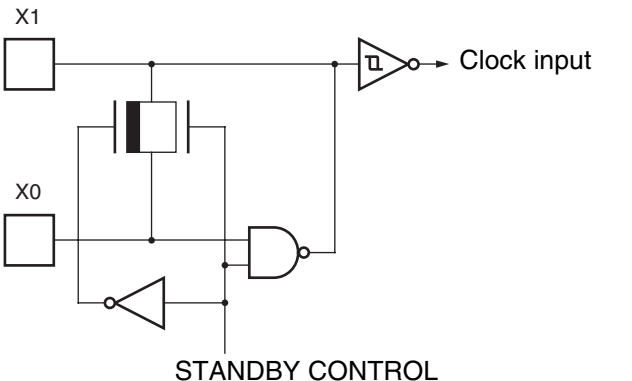
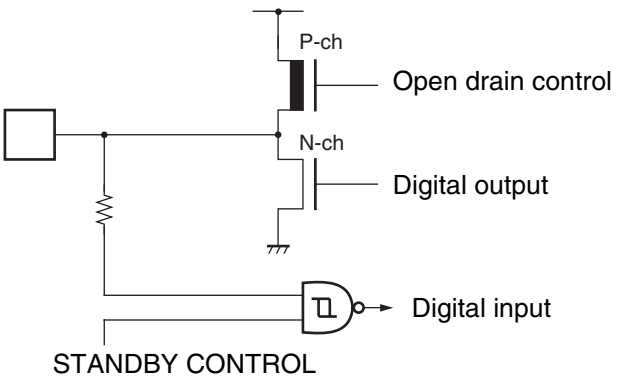
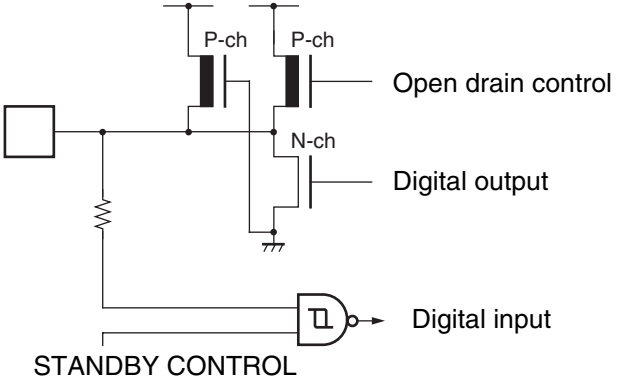
Classification	Circuit type	Remarks
A	 <p style="text-align: center;">STANDBY CONTROL</p>	<ul style="list-style-type: none"> <li>• Oscillation circuit</li> <li>• Feedback resistor</li> <li>• X0 : 1 MΩ</li> </ul>
B	 <p style="text-align: center;">STANDBY CONTROL</p>	<ul style="list-style-type: none"> <li>• CMOS level output</li> <li>• <math>I_{OH} = 4 \text{ mA}</math></li> <li>• With open drain output control</li> <li>• CMOS level hysteresis input</li> <li>• <math>V_{IH} = 0.7 \times V_{CC}</math></li> <li>• With standby control</li> <li>• 5V tolerance</li> </ul>
C	 <p style="text-align: center;">STANDBY CONTROL</p>	<ul style="list-style-type: none"> <li>• CMOS level output</li> <li>• <math>I_{OH} = 4 \text{ mA}</math></li> <li>• With open drain output control</li> <li>• CMOS level hysteresis input</li> <li>• <math>V_{IH} = 0.8 \times V_{CC}</math></li> <li>• With standby control</li> <li>• With pull-up resistor (33 kΩ)</li> </ul>

(Continued)

# MB91345 Series

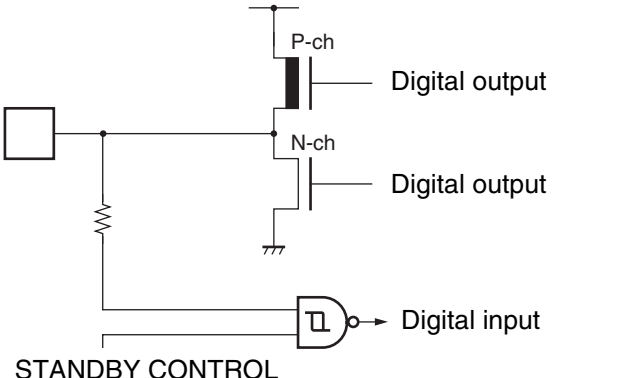
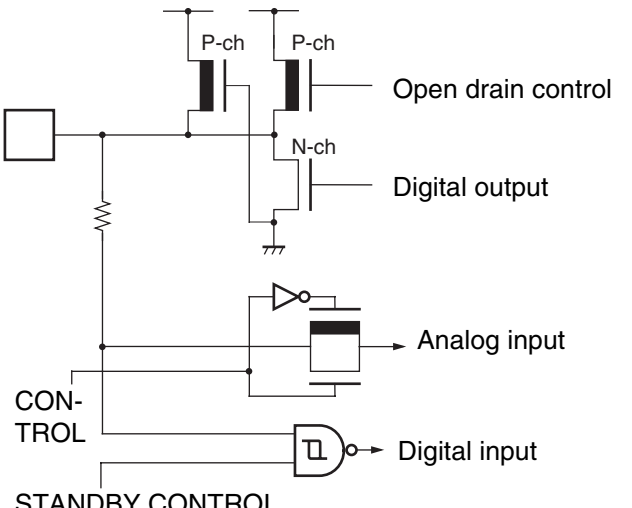
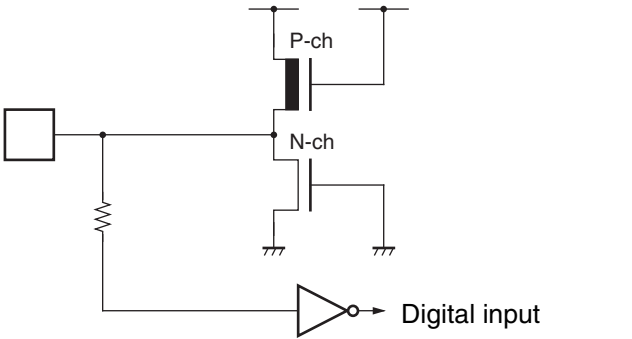
Classification	Circuit type	Remarks
D		<ul style="list-style-type: none"> <li>• CMOS level output <math>I_{OH} = 4 \text{ mA}</math></li> <li>• CMOS level hysteresis input <math>V_{IH} = 0.8 \times V_{CC}</math></li> <li>• Standby control provided</li> <li>• Without pull-up resistor</li> </ul>
E		<ul style="list-style-type: none"> <li>• CMOS level output <math>I_{OH} = 4 \text{ mA}</math></li> <li>• With open drain output control</li> <li>• CMOS level hysteresis input <math>V_{IH} = 0.8 \times V_{CC}</math></li> <li>• With standby control</li> <li>• With analog input switch</li> <li>• With pull-up resistor (33 kΩ)</li> </ul>
F		<ul style="list-style-type: none"> <li>• CMOS level input</li> <li>• Without standby control</li> </ul>

(Continued)

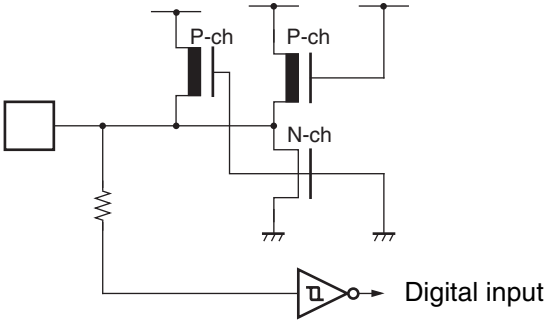
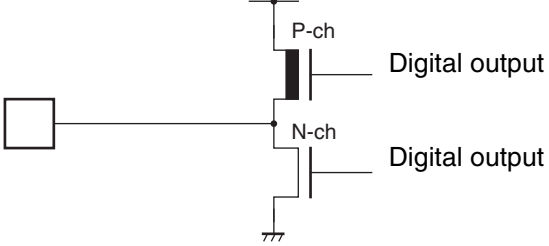
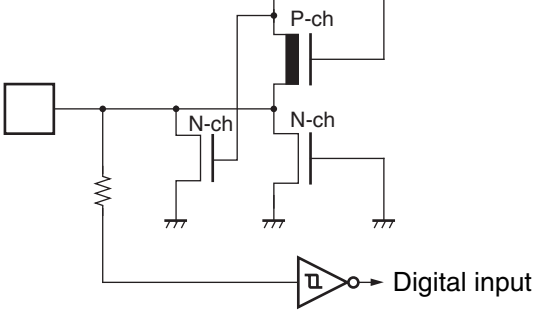
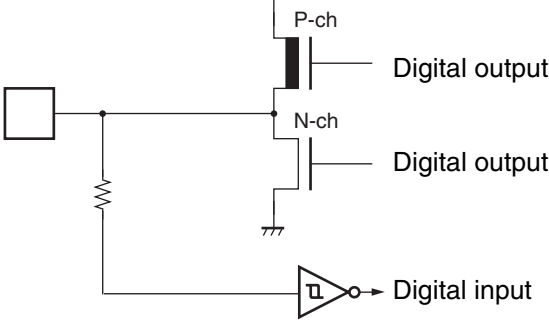
Classification	Circuit type	Remarks
G		<ul style="list-style-type: none"> <li>• CMOS hysteresis input</li> <li>• With pull-up resistor</li> </ul>
H		<p>CMOS level output</p>
I		<ul style="list-style-type: none"> <li>• CMOS hysteresis input</li> <li>• With pull-down resistor</li> <li>• Without standby control</li> </ul>
J		<ul style="list-style-type: none"> <li>• CMOS level output</li> <li>• CMOS level hysteresis input</li> <li>• Without standby control</li> </ul>

(Continued)

# MB91345 Series

(Continued)

Classification	Circuit type	Remarks
K	<p>The diagram illustrates a CMOS level hysteresis input circuit. It features a pull-down resistor connected to a node that branches to the gates of two N-channel MOSFETs. The first N-channel MOSFET's gate is also connected to its drain, which is connected to the gate of a P-channel MOSFET. The P-channel MOSFET's gate is also connected to its drain, which is connected to the gate of the second N-channel MOSFET. The gates of both N-channel MOSFETs are also connected to a digital input through an inverter. The drains of both N-channel MOSFETs are connected to digital outputs.</p>	<ul style="list-style-type: none"> <li>• CMOS level output</li> <li>• CMOS level hysteresis input</li> <li>• Without standby control</li> <li>• With pull-down resistor</li> </ul>

## ■ HANDLING DEVICES

- Preventing Latch-up

Latch-up may occur in a COMS IC if a voltage greater than VCC pin, or less than VSS pin is applied to input and output pins, or if an above-rating voltage is applied between VCC pin and VSS pin. If the latch-up occurs, the significantly increases the power supply current and may cause thermal destruction of an element. Thus, When you use a CMOS IC, be very careful not to exceed maximum voltage rating.

- Treatment of Unused input pins

Do not leave an unused input pin open, since it may cause a malfunction. Thus, use pull-up or pull-down resistor.

- About power supply pins

If there are multiple VCC pin or VSS pin, from the point of view of device design, pins to be of the same level are connected the inside of the device to prevent such malfunctioning as latch-up. Be sure to connect all of them to the power supply and ground externally for reducing unnecessary radiation, prevent malfunctioning of the strobe signal due to the rise of ground level, and observe the total output current standard. In addition, consideration should be given to connecting VCC/VSS of this device with as low an impedance as possible from the current supply source. Also, we recommend connecting a ceramic capacitor of about 0.1  $\mu$ F as a bypass capacitor between VCC and VSS near this device.

- About crystal oscillator circuit

Noise near the X0 and X1 pins can cause this device to malfunction. Design the PC board such that X0 and X1 pins, crystal oscillator (or ceramic oscillator) , and bypass capacitor to the ground are placed as near one another as possible. It is strongly recommended to design the PC board artwork with the X0/X1 pins surrounded by a ground plane, as it expects stable operations.

Please ask the crystal maker to evaluate the oscillational characteristics of the crystal and this device.

- About mode pins (MD0 to MD2)

These pins should be connected directly to VCC or VSS pins. To prevent the device erroneously switching to test mode due to noise, design the PC board such that the distance between the mode pins and VCC or VSS pins is as short as possible and the connection impedance is low.

- About operation at power-on

Be sure to set initialized reset (INIT) with  $\overline{\text{INIT}}$  pin immediately after power-on.

Immediately after turning on the power, be sure to continue connecting the Low level input to the  $\overline{\text{INIT}}$  pin for the stabilization wait time required for oscillator circuit, to secure the stabilization wait time of the oscillator and regulator (For INIT via the  $\overline{\text{INIT}}$  pin, the oscillation stabilization wait time setting is initialized to the minimum value) .

- About oscillation input at power on

When turning on the power, be sure that clock input is maintained until the device is released from the oscillation stabilization wait state.

- Note on power-on/off sequences

When turning on the power, the output pin may be indeterminate until the internal power supply stabilizes.

# MB91345 Series

- Note when using external clock

In principle, when using external clock, supply a clock to the X0 pin and an opposite-phase clock signal to the X1 pin simultaneously. However in this case, the STOP mode (oscillator stop mode) must not be used, because the X1 pin stops with the “H” output in the STOP mode. At 12.5 MHz or less, the device can be used with the clock signal supplied only to the X0 pin.

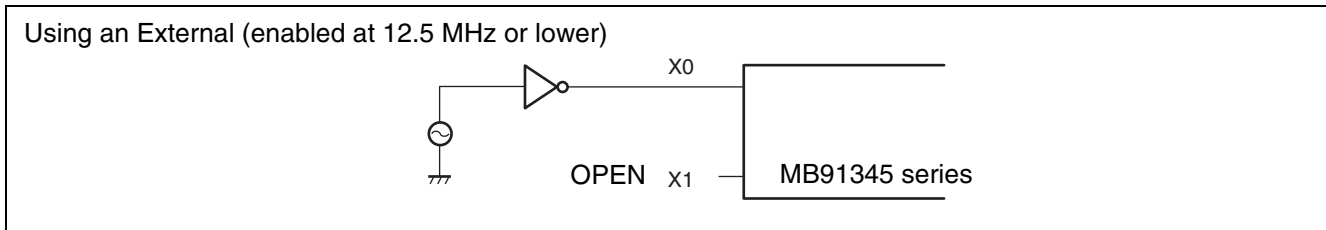
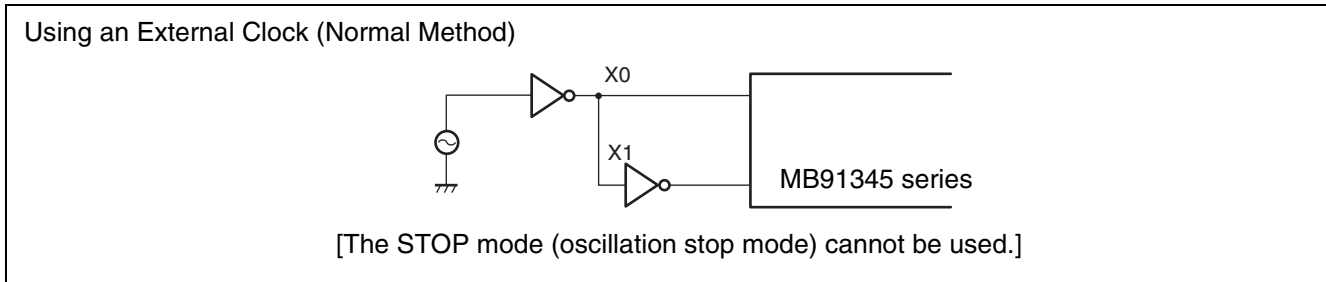

Note : The X1 pin must be designed to have a delay within 15 ns, at 10 MHz, from the signal to the X0 pin.

- About C pin

MB91345 series has an internal regulator. A bypass condenser of 4.7  $\mu\text{F}$  or above should be connected to the C pin for the regulator.

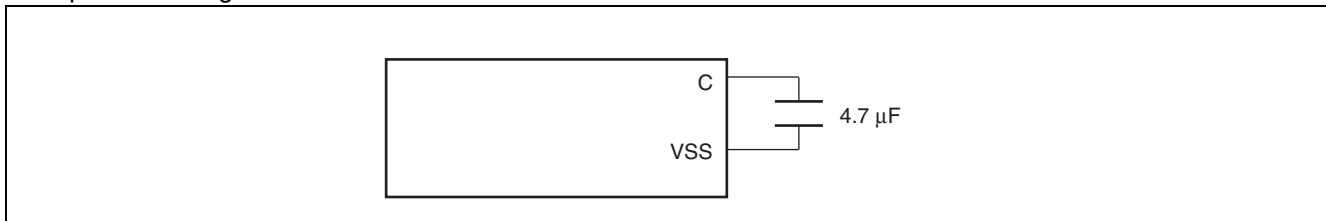

- About AVCC pin

MB91345 series has an internal A/D converter. A condenser of approximately 0.1  $\mu\text{F}$  should be connected between the AVCC pin and AVSS pin.

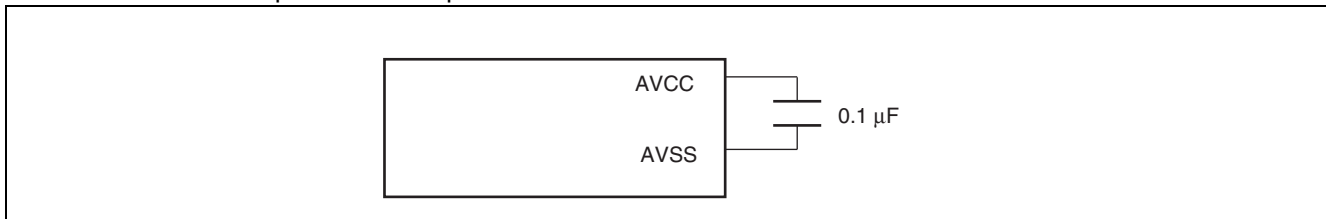

- Treatment of NC pin and OPEN pin

The NC and OPEN pins should always be open.

- Note when not using emulator

If evaluation MCU on user system is operated without emulator, each input pin on evaluation MCU connected to the emulator interface on the user system should be handled, as described in the following table. Note that the switch circuit or other function may be required on user system when designing the MCU.

Emulator Interface Pin Treatment

<b>Evaluation MCU pin name</b>	<b>Pin processing</b>
$\overline{\text{TRST}}$	Connect to the reset output circuit on the user system.
$\overline{\text{INIT}}$	Connect to the reset output circuit on the user system.
Others	Open.

## ■ RESTRICTIONS

### • Common in the series

- Clock control block  
Take the oscillation stabilization wait time during Low level input to  $\overline{\text{INIT}}$  pin.
- Bit search module  
The bit search data register for 0-detection (BSD0) , and bit search data register for 1-detection (BSD1) , and bit search data register for change point detection (BSDC) are only word-accessible.
- I/O port  
Ports are accessed only in bytes.
- Low power consumption mode
- To enter the standby mode, use the synchronous standby mode (set with the SYNCS bit as bit8 in TBCR, or timebase counter control register) and be sure to use the following sequence :

```
(ldi      #value_of_standby, r0)
(ldi      #_STCR, r12)
stb      r0, @r12      // set STOP/SLEEP bit
ldub     @r12, r0      // Must read STCR
ldub     @r12, r0      // after reading, go into standby mode
nop      // Must insert NOP *5
nop
nop
nop
nop
```
- Please do not do the following when the monitor debugger is used
  - Setting of the break point to the above instructions.
  - Execution of the single-stepping for the above instructions.

- Notes on the PS register

As the PS register is processed by some instructions in advance, exception handling below may cause the interrupt handling routine to break when the debugger is used or the display contents of flags in the PS register to be updated. In either case, the operations before and after an EIT are performed as specified as the device is designed such that the recovery from the EIT is followed by correct re-processing.

- The instruction just before the DIV0U/DIV0S instruction may cause the following operation, if a user interrupt or NMI occurs, single-stepping is performed or a break is caused by a data event or emulator menu :

- (1) The D0 and D1 flags are updated in advance.

- (2) An EIT handling routine (user interrupt, NMI, or emulator) is executed.

- (3) Upon returning from the EIT, the DIV0U/DIV0S instruction is executed and the D0 and D1 flags are updated to the same values as shown in (1) .

- If the ORCCR/STILM/MOV Ri and PS instructions are executed to enable interruptions when a user interrupt or NMI trigger even has occurred, the following operations are performed.

- (1) The PS register is updated in advance.

- (2) An EIT handling routine (user interrupt, NMI, or emulator) is executed.

- (3) Upon returning from the EIT, the instructions shown above are executed and the PS register is updated to the same value as shown in (1) .

- About watchdog timer

MB91345 series has an internal function called “watchdog timer”. This function monitors a program to perform the reset defer operation within a certain period of time. The watchdog timer resets the CPU if the program runs out of controls and the reset defer operation is not executed. Thus, once enabled, the watchdog timer will be up and running until it resets the CPU. However, with one exception, the watchdog timer automatically defers a reset timing under the condition in which the CPU stops program execution. Refer to the hardware manual. If the system runs out of control and develops the above condition, a watchdog reset may not be generated. In that case, please reset (INIT) from external  $\overline{\text{INIT}}$  terminal.

- Note on using the A/D converter

MB91345 series has an internal A/D converter. The AVCC pin should not be supplied with higher voltage than VCC pin.

- Software reset in synchronous mode

When using the software reset in the synchronous mode, the following two conditions should be satisfied before setting “0” to the SRST bit in STCR (Standby control register) .

- Set the interrupt enable flag (I-Flag) to interrupt disable (I-Flag = 0) .
- Do not use NMI.

- Debug control when using ICE

- Single-stepping of the RETI instruction

If an interrupt occurs frequently during single stepping, only the relevant interrupt processing routine is executed repeatedly after single-stepping RETI. This will prevent the main routine and low-interrupt-level programs from being executed. Do not single-step the RETI instruction for escape. When the debugging of the relevant interrupt routine no longer requires, perform debugging with that interrupt disabled.

- About operand break

Do not apply a data event break to access to the area containing the address of a stack pointer.

# MB91345 Series

- Execution of an unused area of Flash memory  
Accidentally if an unused area (data at 0XFFFF) of Flash memory is executed in an instruction, no break can be accepted. To avoid this, it is recommended to use the code event address mask feature of the debugger to break at instruction access to the unused area.
- Interrupt handler for NMI request (tool)  
Add the following program to the interrupt handler to prevent the device from malfunctioning when the source flag is set accidentally with no ICE connected, for example, due to noise to the DSU pin, which is to be set only at the break request of the ICE. can be used normally with this program added.

Add place :

Next interrupt handler

Interrupt source : NMI request (tool)

Interrupt number : 13 (decimal) , 0D (hexadecimal)

Offset : 3C8H

TBR default address : 000FFFC8H

Add program

STM (R0, R1)

LDI #0B00H, R0 ; 0B00H is the address of DSU break source register

LDI #0, R1

STB R1, @R0 ; Clear the break source register

LDM (R0, R1)

RETI

## ■ BLOCK DIAGRAM

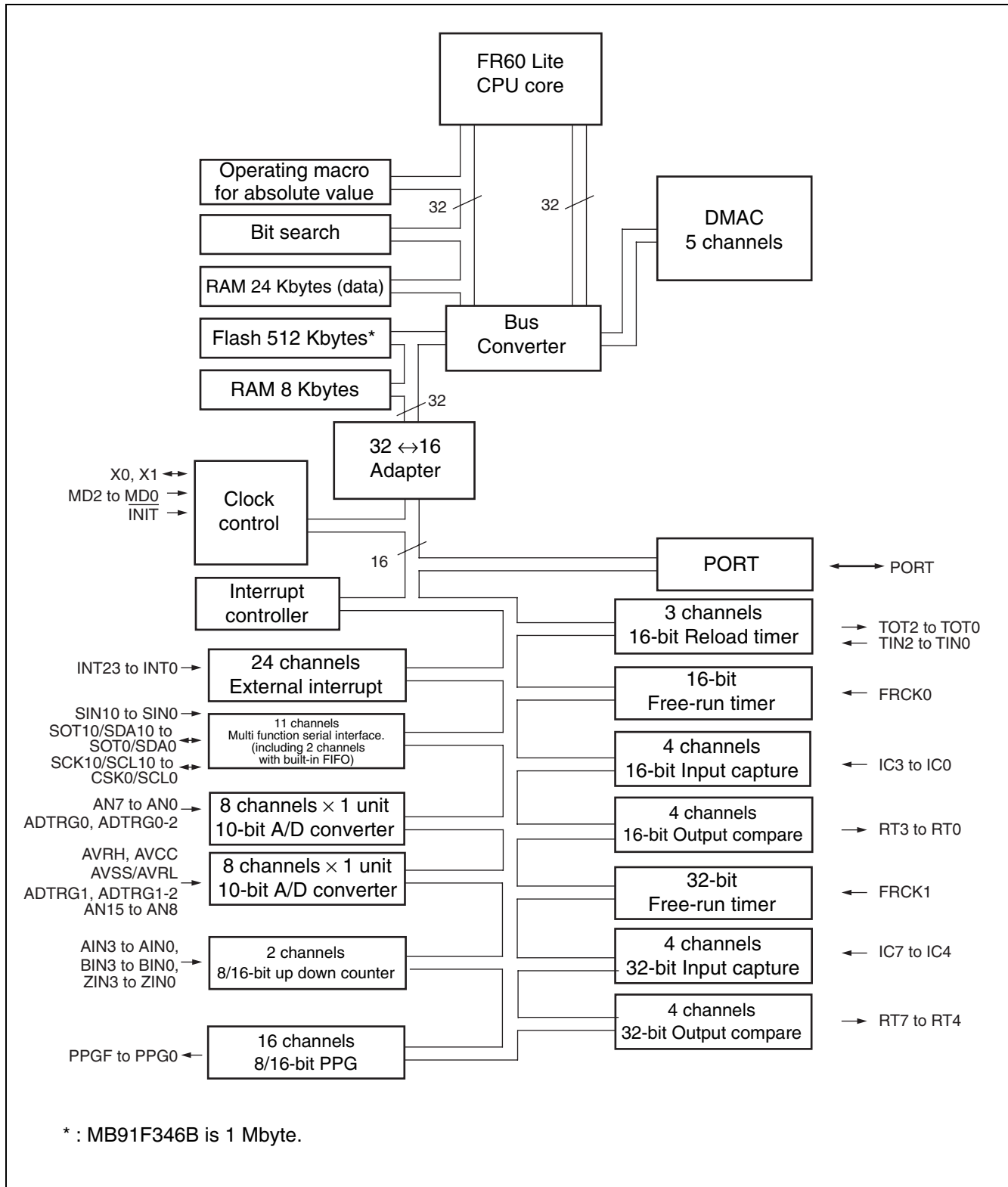

# MB91345 Series

## ■ CPU AND CONTROL UNIT

The FR family CPU is a line of high-performance cores based on a RISC architecture while incorporating advanced instructions for embedded controller applications.

### 1. Features

- RISC architecture adopted.  
Basic instructions : Executed at 1 instruction per cycle
- 32-bit architecture  
General purpose registers : 32 bit × 16
- 4G bytes of linear memory space
- Multiplier integrated.  
32-bit × 32-bit multiplication : 5 cycles.  
16-bit × 16-bit multiplication : 3 cycles
- Enhanced interrupt servicing.  
High-speed response (6 cycles) .  
Multi-level interrupts support.  
Level mask feature (16 levels)
- Enhanced I/O manipulation instructions.  
Memory-to-memory transfer instructions  
Bit manipulation instructions
- High code efficiency. Basic instruction word length : 16-bit
- Low-power consumption.  
Sleep mode / stop mode
- Gear function

## 2. Internal architecture

The FR-family CPU has a Harvard architecture in which the instruction bus and data buses are separated. The 32-bit $\leftrightarrow$ 16-bit bus converter is connected to a 32-bit bus (F-bus), providing an interface between the CPU and peripheral resources. The Harvard $\leftrightarrow$ Princeton bus converter is connected to both of the I-bus and D-bus, providing an interface between the CPU and the bus controller.

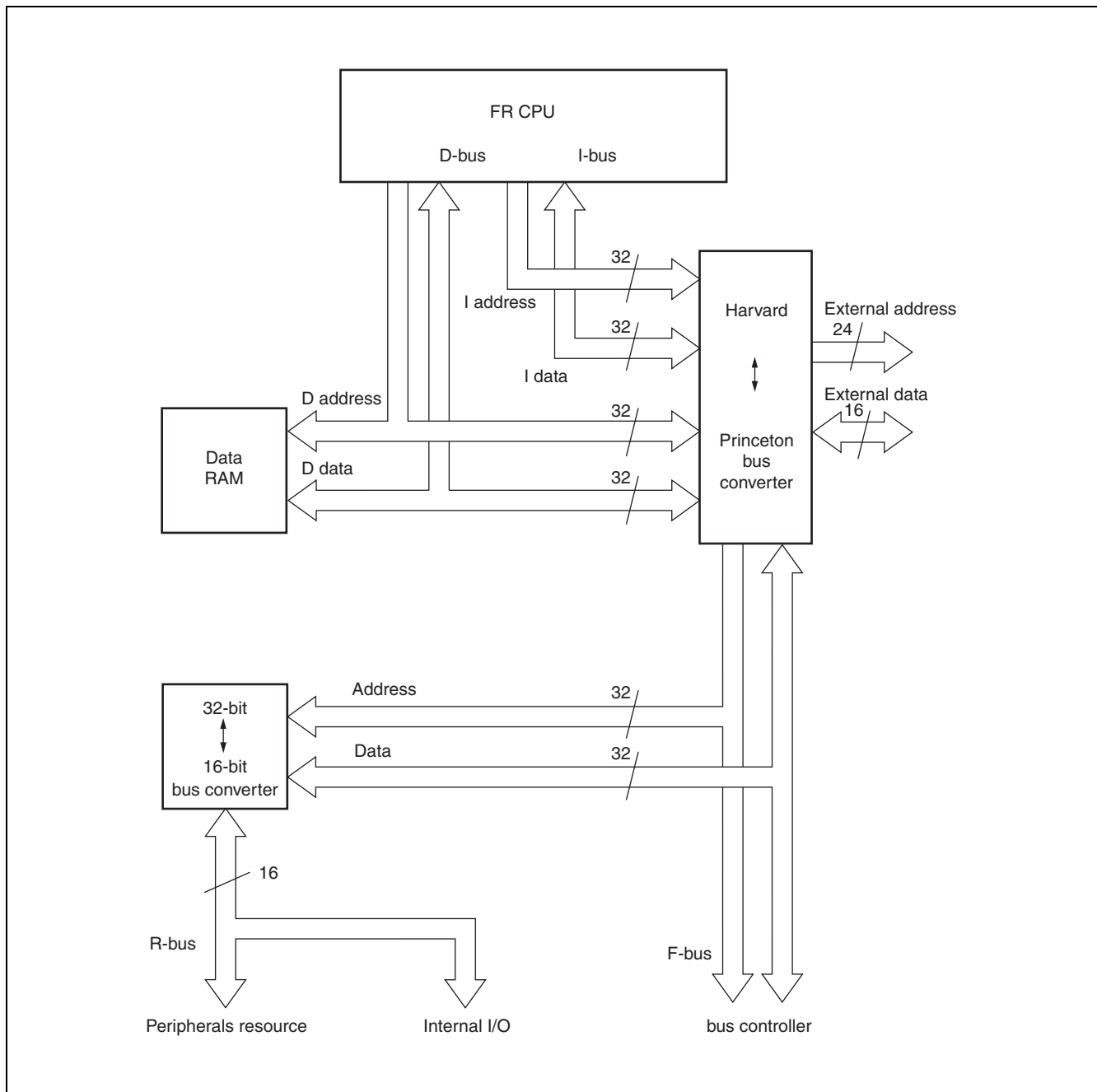

# MB91345 Series

## 3. Programming model

### Basic programming model

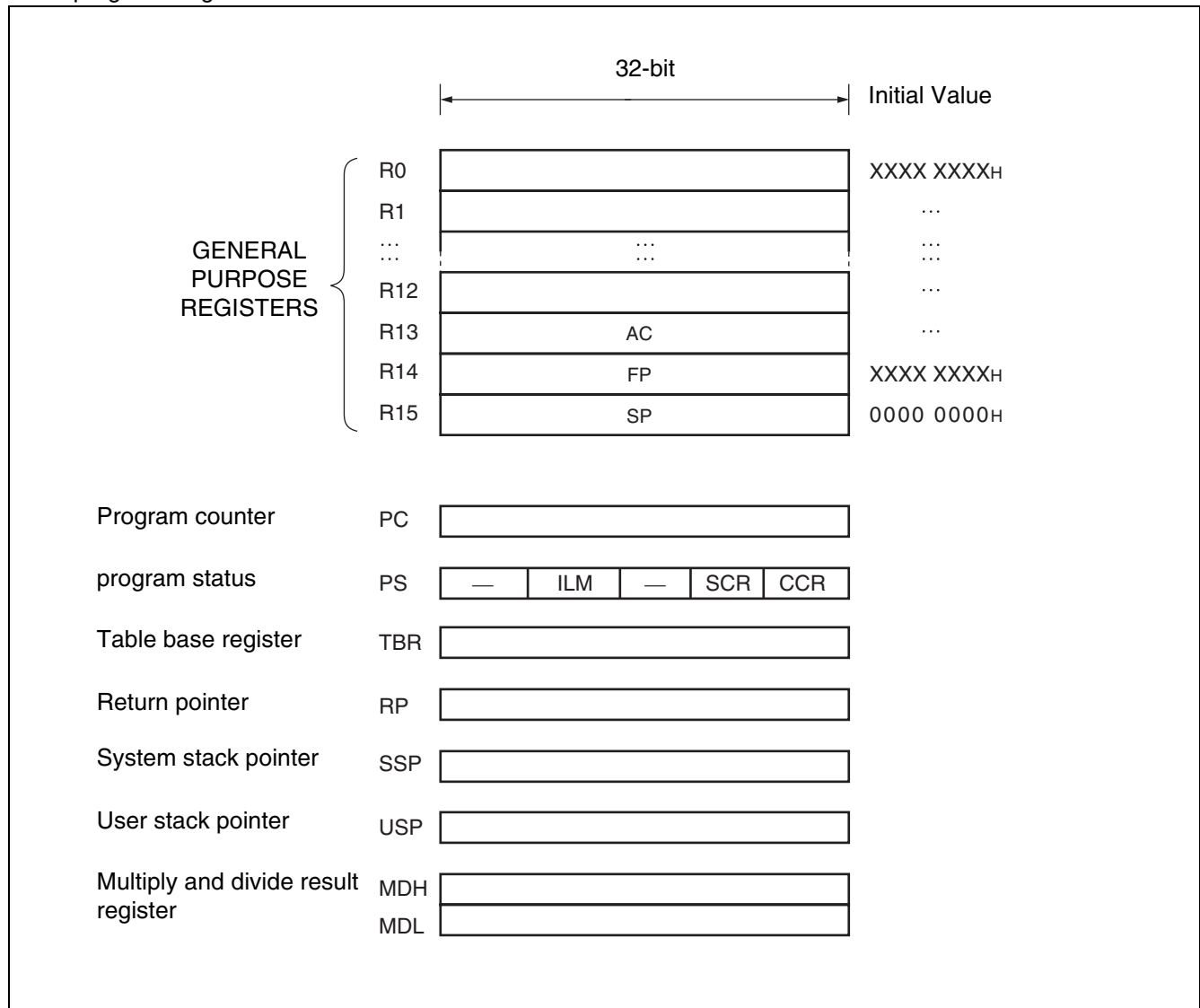

## 4. Register

### General purpose registers

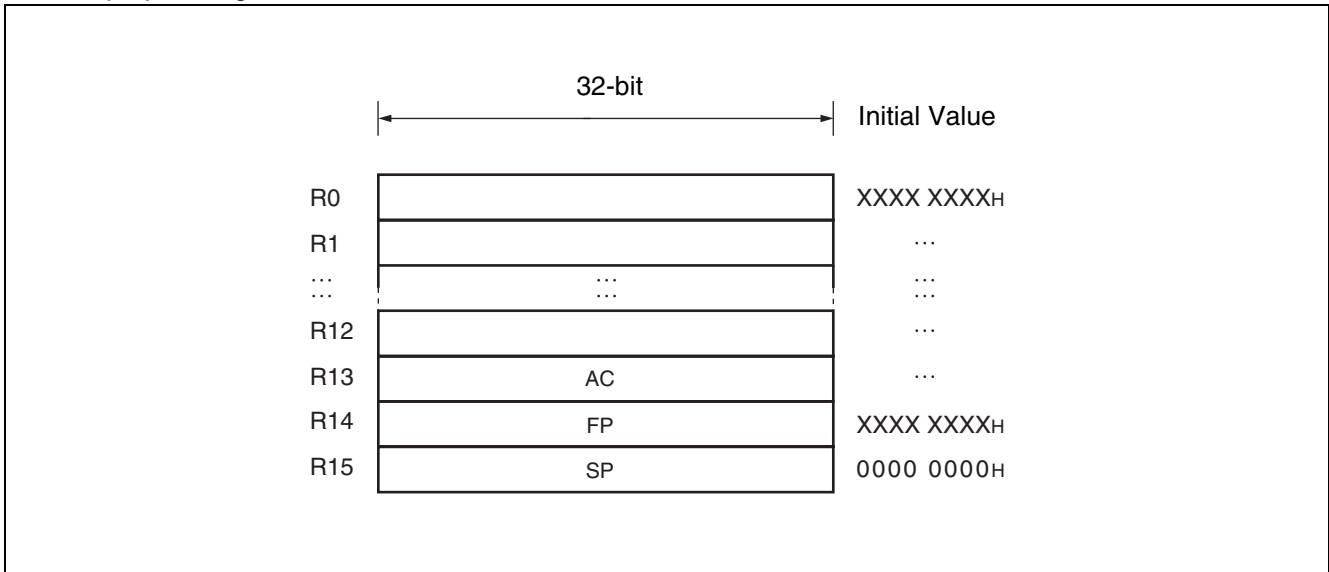

Registers R0 to R15 are general purpose registers. The registers are used as the accumulator and memory access pointers for CPU operations.

Of these 16 registers, the registers listed below are intended for special applications, for which some instructions are enhanced.

- R13 : Virtual accumulator
- R14 : Frame pointer
- R15 : Stack pointer

The initial values of R0 to R14 after a reset are indeterminate. R15 is initialized to 00000000H (SSP value) .

- PS (Program Status)

This register holds the program status and is divided into the ILM, SCR, and CCR.

All of undefined bits are reserved bits. Reading these bits always returns "0".

Writing to them has no effect.

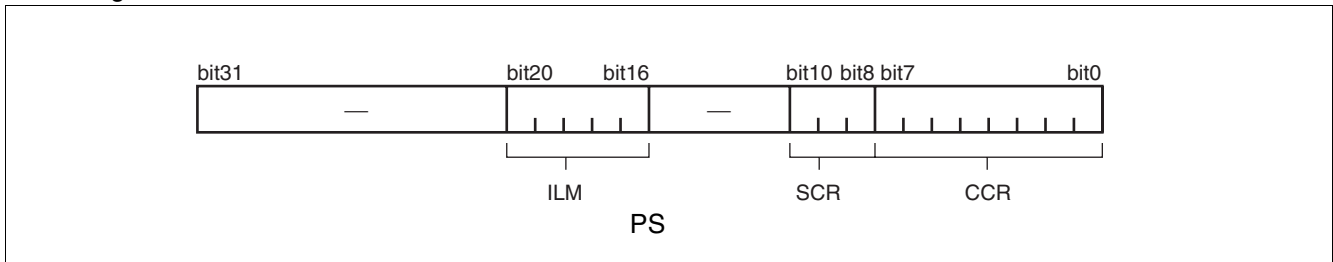

- CCR (Condition Code Register)

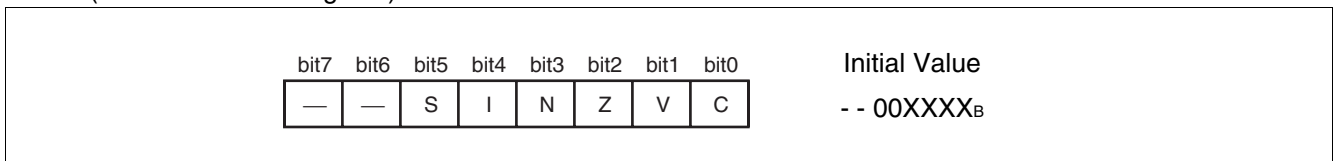

S : Stack flag. Cleared to "0" at a reset.

# MB91345 Series

- I : Interrupt Enable flag. Cleared to “0” at a reset.
- N : Negative flag. Initial State at a reset is unspecified.
- Z : Zero flag. Initial State at a reset is unspecified.
- V : Overflow flag. Initial State at a reset is unspecified.
- C : Carry flag. Initial State at a reset is unspecified.

- SCR (System Condition code Register)

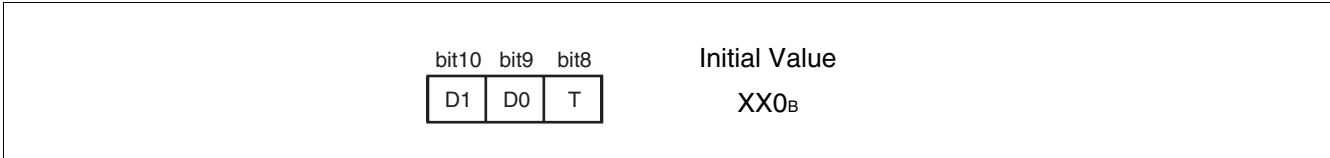

Flag for step dividing

Stores intermediate data for stepwise multiplication operations.

Step trace trap flag

A flag specifying whether the step trace trap function is enabled or not.

Emulator uses step trace trap function. The function cannot be used by the user program when using the emulator.

- ILM (Interrupt Level Mask Register)

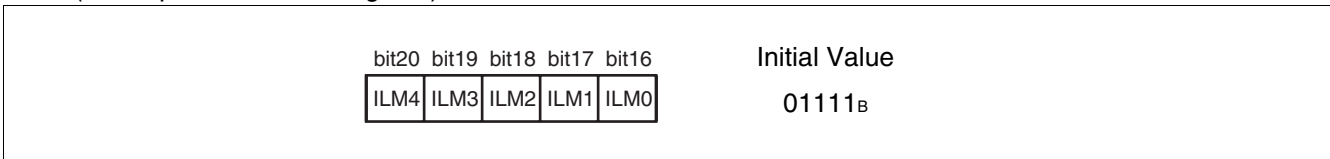

This register stores the interrupt level mask value. The value in the ILM register is used as the level mask. Initialized to “15” (01111<sub>B</sub>) by a reset.

- PC (Program Counter)

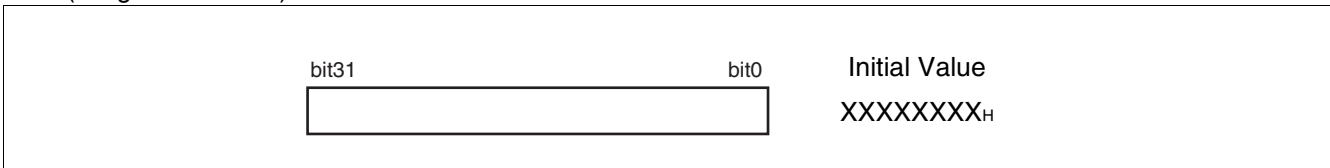

The program counter contains the address of the instruction currently being executed. The initial value after a reset is indeterminate.

- TBR (Table Base Register)

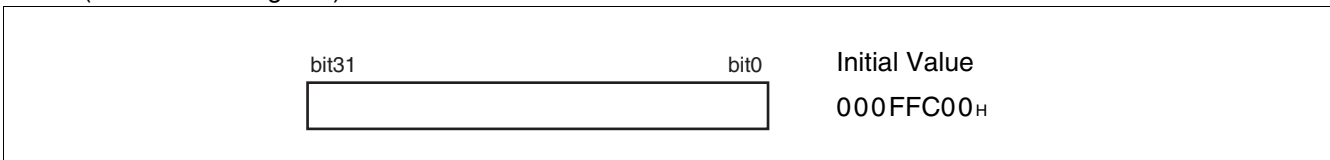

The table base register contains the start address of the vector table used for servicing EIT events. The initial value after a reset is 000FFC00<sub>H</sub>.

- RP (Return Pointer)

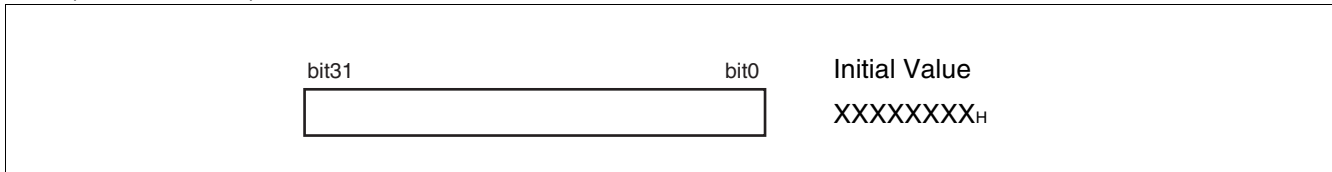

The return pointer contains the address to which to return from a subroutine. When the CALL instruction is executed, the value in the PC is transferred to the RP. When the RET instruction is executed, the value in the RP is transferred to the PC. The initial value after a reset is indeterminate.

- SSP (System Stack Pointer)

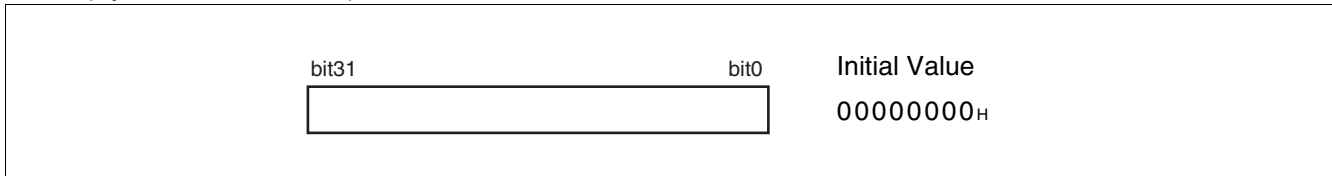

The SSP is the system stack pointer and functions as R15 when the S flag is “0”. The SSP can be explicitly specified. The SSP is also used as the stack pointer that specifies the stack for saving the PS and PC when an EIT event occurs. The initial value after a reset is 00000000H.

- USP (User Stack Pointer)

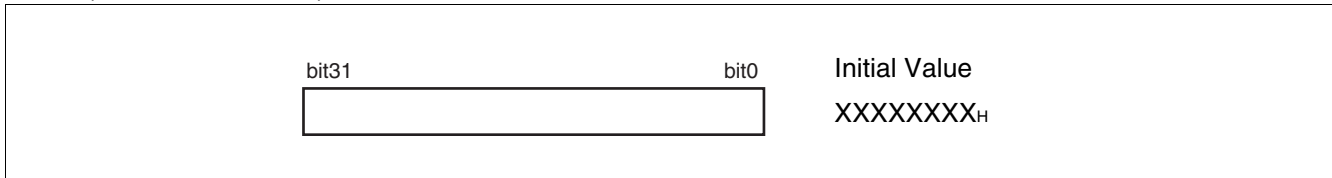

The USP is the user stack pointer and functions as R15 when the S flag is “1”. The USP can be explicitly specified. The initial value after a reset is indeterminate. This pointer cannot be used by the RETI instruction.

- MDH, MDL (Multiply and Divide register)

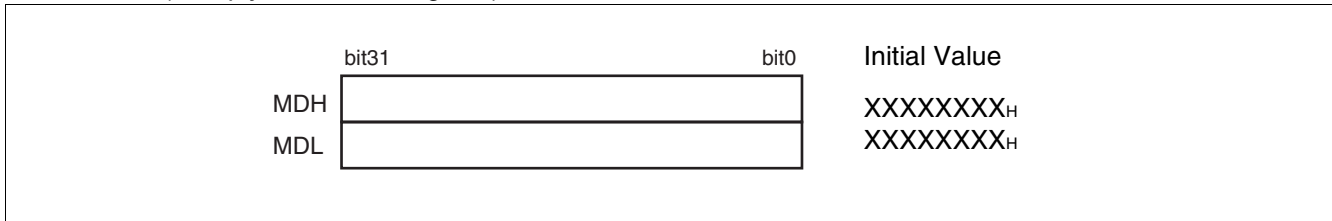

These registers hold the results of a multiplication or division. Each of them is 32-bit long. The initial value after a reset is indeterminate.

# MB91345 Series

## MODE SETTING

In the FR family, operation mode is set by the mode setting pins (MD2, MD1, MD0) and the mode register (MODR).

### 1. Mode pins

They are three pins of MD2, MD1 and MD0, and specify the contents of the mode vector fetch.

Mode pins			Mode name	Reset vector Access area
MD2	MD1	MD0		
0	0	0	Internal ROM mode vector	Internal

Note : In the FR family, external mode vector fetch by multiplex bus is not supported.

### 2. Mode register (MODR)

The data that are written in the mode register by mode vector fetch is called mode data.

After the mode register (MODR) is set, it operates in the operation mode set by this register.

The mode register is set by all reset source. And Mode data is not written in by the user program.

Note : Conventionally, the address (0000 07FF<sub>H</sub>) of the mode register for the FR family holds nothing.

#### Details of the mode register

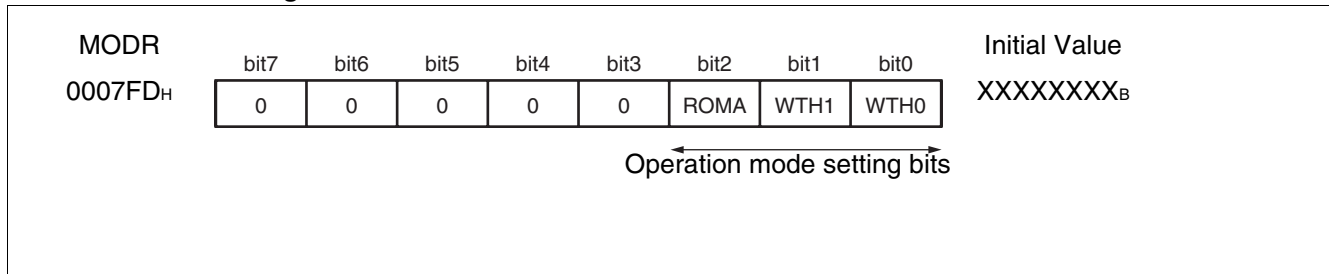

[bit7 to bit3] Reserved bits

Be sure to set these bits to “00000<sub>B</sub>”.

Setting the bits to any value other than “00000<sub>B</sub>” may result in an unpredictable operation .

[bit2] ROMA (Internal ROM enable bit)

Be sure to set this bit to “1”.

ROMA	Function	Remarks
0	—	Setting disabled
1	Internal ROM mode	Embedded F-bus RAM and F-bus ROM become valid.

[bit1, bit0] WTH1, WTH0 (Bus width specifying bits)

Be sure to set these bits to "11<sub>B</sub>".

WTH1	WTH0	Function	Remarks
0	0	—	Setting disabled
0	1	—	Setting disabled
1	0	—	Setting disabled
1	1	Single chip mode	Single chip mode

# MB91345 Series

## ■ MEMORY SPACE

### 1. Memory Space

The FR family has 4 Gbytes of logical address space ( $2^{32}$  addresses) linearly accessible to the CPU .

- Direct Addressing Areas

The following address space areas are used as I/O areas.

These areas are called direct addressing areas, in which the address of an operand can be specified directly during an instruction.

The direct area varies depending on the size of data to be accessed as follows :

- byte data access : 000<sub>H</sub> to 0FF<sub>H</sub>
- half word data access : 000<sub>H</sub> to 1FF<sub>H</sub>
- word data access : 000<sub>H</sub> to 3FF<sub>H</sub>

### 2. Memory Map (MB91F345B/F346B)

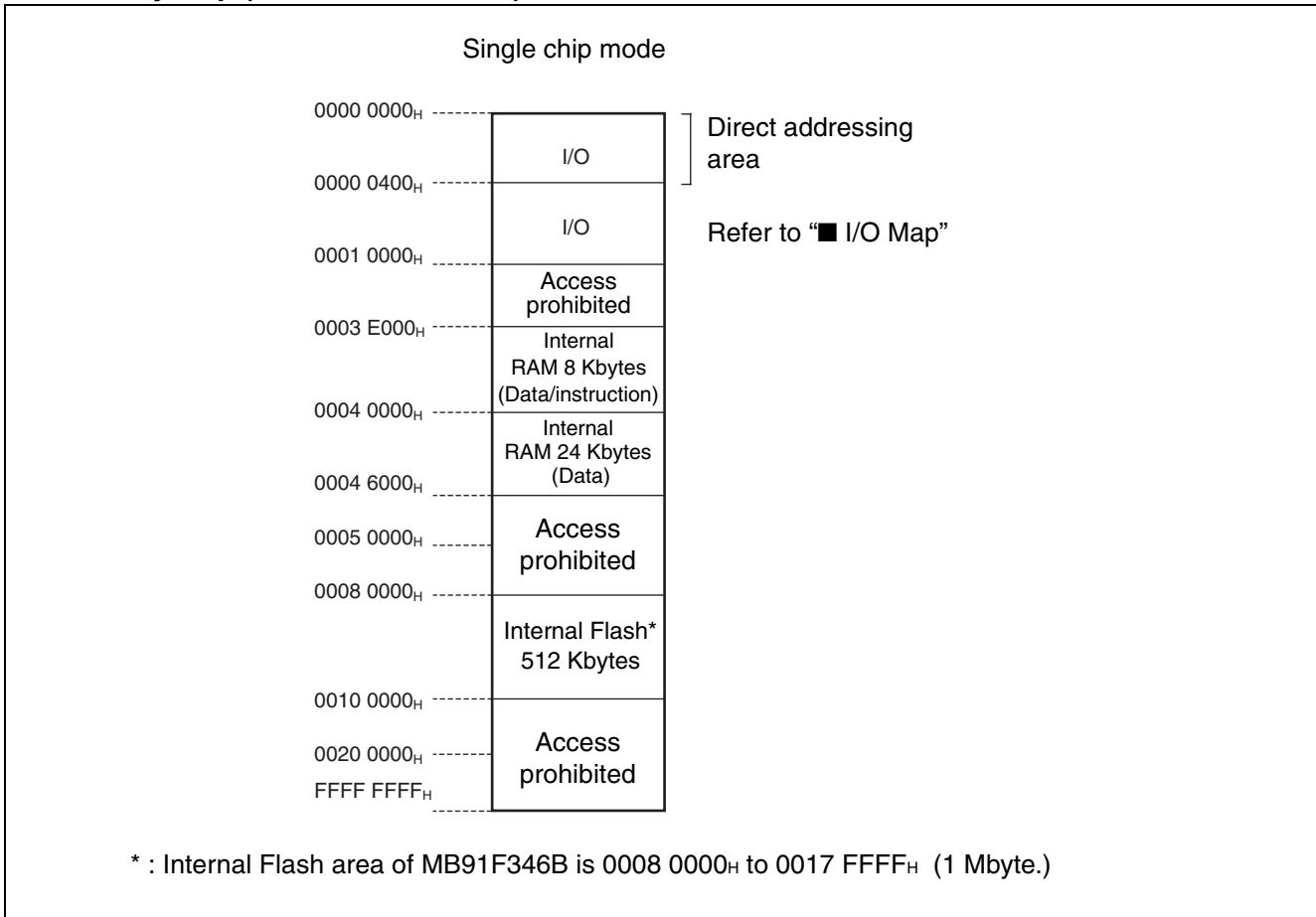

## ■ I/O MAP

The following table shows the correspondence between the memory space area and each register of the peripheral resource.

[How to read the table]

Address	Register				Block
	+ 0	+ 1	+ 2	+ 3	
000000 <sub>H</sub>	PDR0 [R/W] B ↑XXXXXXXX↑	PDR1 [R/W] B XXXXXXXX	PDR2 [R/W] B XXXXXXXX	PDR3 [R/W] B XXXXXXXX	T-unit Port Data Register

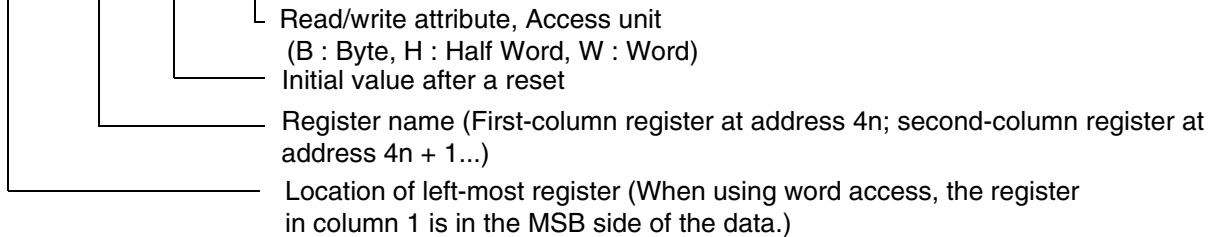

Note : Initial values of register bits are represented as follows :

“1” : Initial value is “1”.

“0” : Initial value is “0”.

“X” : Initial value is “indeterminate”.

“\_” : No physical register at this location

Access is barred with an undefined data access attribute.

# MB91345 Series

Address	Register				Block
	0	1	2	3	
000000 <sub>H</sub>	PDR0 [R/W] B, H XXXXXXXX	PDR1 [R/W] B, H XXXXXXXX	PDR2 [R/W] B, H XXXXXXXX	PDR3 [R/W] B, H XXXXXXXX	Port Data Registers
000004 <sub>H</sub>	PDR4 [R/W] B, H XXXXXXXX	PDR5 [R/W] B, H XXXXXXXX	PDR6 [R/W] B, H ----XXXX	—	
000008 <sub>H</sub>	—				
00000C <sub>H</sub>	PDRC [R/W] B, H ----XXX	PDRD [R/W] B, H XXXXXXXX	PDRE [R/W] B, H XXXXXXXX	—	
000010 <sub>H</sub> to 00001C <sub>H</sub>	—				Reserved
000020 <sub>H</sub>	—			ADERH0 [R/W] 11111111	A/D converter 0
000024 <sub>H</sub>	ADCS01 [R/W] 00000000	ADCS00 [R, R/W] 00000000	ADCR0 [R] -----XX XXXXXXXX		
000028 <sub>H</sub>	ADCT0 [R/W] 00010000 00101100		ADSCH0 [R/W] 0---0000	ADECH0 [R/W] ----0000	
00002C <sub>H</sub>	ADCR0M [R] -----XX XXXXXXXX		ADCR1M [R] -----XX XXXXXXXX		A/D mirror data register
000030 <sub>H</sub>	—			ADERH1 [R/W] 11111111	A/D converter 1
000034 <sub>H</sub>	ADCS11 [R/W] 00000000	ADCS10 [R, R/W] 00000000	ADCR1 [R] -----XX XXXXXXXX		
000038 <sub>H</sub>	ADCT1 [R/W] 00010000 00101100		ADSCH1 [R/W] 0---000	ADECH1 [R/W] ----000	
00003C <sub>H</sub>	—				Reserved
000040 <sub>H</sub>	EIRR0 [R/W] 00000000	ENIR0 [R/W] 00000000	ELVR0 [R/W] 00000000 00000000		External interrupt INT 0 to INT7
000044 <sub>H</sub>	DICR [R/W] 00000000	HRCL [R, R/W] 0--11111	—		DLY / I-unit
000048 <sub>H</sub>	TMRLR0 [W] XXXXXXXX XXXXXXXX		TMR0 [R] XXXXXXXX XXXXXXXX		Reload Timer 0
00004C <sub>H</sub>	—		TMCSR0 [R, RW] 00000000 00000000		
000050 <sub>H</sub>	TMRLR1 [W] XXXXXXXX XXXXXXXX		TMR1 [R] XXXXXXXX XXXXXXXX		Reload Timer 1
000054 <sub>H</sub>	—		TMCSR1 [R, RW] 00000000 00000000		

(Continued)

# MB91345 Series

Address	Register				Block
	0	1	2	3	
000058 <sub>H</sub>	TMRLR2 [W] XXXXXXXXXX XXXXXXXXXX		TMR2 [R] XXXXXXXXXX XXXXXXXXXX		Reload Timer 2
00005C <sub>H</sub>	—		TMCSR2 [R, RW] 00000000 00000000		
000060 <sub>H</sub>	SCR0/IBCR0 [R, R/W] *	SMR0 [W, R/W] *	SSR0 [R, R/W] *	ESCR0/IBSR0 [R/W] *	Multi function Serial Interface 0 FIFO 0
000064 <sub>H</sub>	RDR0/TDR0 [R/W] *		BGR01 [R/W] *	BGR00 [R/W] *	
000068 <sub>H</sub>	ISMK0 [R/W] *	IBSA [R/W] *	FCR01 [R/W] *	FCR00 [R/W] *	
00006C <sub>H</sub>	FBYTE02 [R/W] *	FBYTE01 [R/W] *	—		
000070 <sub>H</sub>	SCR1/IBCR1 [R, R/W] *	SMR1 [W, R/W] *	SSR1 [R, R/W] *	ESCR1/IBSR1 [R/W] *	
000074 <sub>H</sub>	RDR1/TDR1 [R/W] *		BGR11 [R/W] *	BGR10 [R/W] *	Multi function Serial Interface 1 FIFO 1
000078 <sub>H</sub>	ISMK1 [R/W] *	IBSA1 [R/W] *	FCR11 [R/W] *	FCR10 [R/W] *	
00007C <sub>H</sub>	FBYTE12 [R/W] *	FBYTE11 [R/W] *	—		
000080 <sub>H</sub>	SCR2/IBCR2 [R, R/W] *	SMR2 [W, R/W] *	SSR2 [R, R/W] *	ESCR2/IBSR2 [R/W] *	Multi function Serial Interface 2
000084 <sub>H</sub>	RDR2/TDR2 [R/W] *		BGR21 [R/W] *	BGR20 [R/W] *	
000088 <sub>H</sub>	ISMK2 [R/W] *	IBSA2 [R/W] *	—		
00008C <sub>H</sub>	—				
000090 <sub>H</sub>	SCR3/IBCR3 [R, R/W] *	SMR3 [W, R/W] *	SSR3 [R, R/W] *	ESCR3/IBSR3 [R/W] *	Multi function Serial Interface 3
000094 <sub>H</sub>	RDR3/TDR3 [R/W] *		BGR31 [R/W] *	BGR30 [R/W] *	
000098 <sub>H</sub>	ISMK3 [R/W] *	IBSA3 [R/W] *	—		
00009C <sub>H</sub>	—				

(Continued)

# MB91345 Series

Address	Register				Block
	0	1	2	3	
0000A0 <sub>H</sub>	SCR4/IBCR4 [R, R/W] *	SMR4 [W, R/W] *	SSR4 [R, R/W] *	ESCR4/IBSR4 [R/W] *	Multi function Serial Interface 4
0000A4 <sub>H</sub>	RDR4/TDR4 [R/W] *		BGR41 [R/W] *	BGR40 [R/W] *	
0000A8 <sub>H</sub>	ISMK4 [R/W] *	IBSA4 [R/W] *	—		
0000AC <sub>H</sub>	—				
0000B0 <sub>H</sub>	SCR5/IBCR5 [R, R/W] *	SMR5 [W, R/W] *	SSR5 [R, R/W] *	ESCR5/IBSR5 [R/W] *	Multi function Serial Interface 5
0000B4 <sub>H</sub>	RDR5/TDR5 [R/W] *		BGR51 [R/W] *	BGR50 [R/W] *	
0000B8 <sub>H</sub>	ISMK5 [R/W] *	IBSA5 [R/W] *	—		
0000BC <sub>H</sub>	—				
0000C0 <sub>H</sub>	EIRR1 [R/W] 00000000	ENIR1 [R/W] 00000000	ELVR1 [R/W] 00000000 00000000		External interrupt INT 8 to INT15
0000C4 <sub>H</sub>	EIRR2 [R/W] 00000000	ENIR2 [R/W] 00000000	ELVR2 [R/W] 00000000 00000000		External interrupt INT 16 to INT 23
0000C8 <sub>H</sub> to 0000CC <sub>H</sub>	—				Reserved
0000D0 <sub>H</sub>	CPCLRB/CPCLR [R/W] H 11111111 11111111		TCDT [R/W] H 00000000 00000000		16-bit Free-run Timer 0
0000D4 <sub>H</sub>	TCCSH [R/W] B 00000000	TCCSL [R/W] B 01000000	—		
0000D8 <sub>H</sub>	—				Reserved
0000DC <sub>H</sub>	IPCPH0/IPCPL0 [R] XXXXXXXX XXXXXXXX		IPCPH1/IPCPL1 [R] XXXXXXXX XXXXXXXX		16-bit Input Capture
0000E0 <sub>H</sub>	IPCPH2/IPCPL2 [R] XXXXXXXX XXXXXXXX		IPCPH3/IPCPL3 [R] XXXXXXXX XXXXXXXX		
0000E4 <sub>H</sub>	ICSH01 [R/W] -----00	ICSL01 [R/W] 00000000	ICSH23 [R/W] -----00	ICSL23 [R/W] 00000000	
0000E8 <sub>H</sub>	OCCPH0/OCCPL0 [R/W] XXXXXXXX XXXXXXXX		OCCPH1/OCCPL1 [R/W] XXXXXXXX XXXXXXXX		Output Compare 0, 1
0000EC <sub>H</sub>	OCCPH2/OCCPL2 [R/W] XXXXXXXX XXXXXXXX		OCCPH3/OCCPL3 [R/W] XXXXXXXX XXXXXXXX		Output Compare 2, 3
0000F0 <sub>H</sub>	OCS01 [R/W] 11101100 00001100		OCS23 [R/W] 11101100 00001100		Output Compare 0 to 3 Control

(Continued)

# MB91345 Series

Address	Register				Block
	0	1	2	3	
0000F4 <sub>H</sub>	OCMOD [R/W] B 00000000	—			Output Compare Mode Select
0000F8 <sub>H</sub>	PWCSR0 [R/W, R] B, H, W 0000000X 00000000		PWCR0 [R] H, W 00000000 00000000		PWC
0000FC <sub>H</sub>	—	PDIVR0 [R/W] B, H, W XXXXXX000	—		
000100 <sub>H</sub>	PRLH0 [R/W] B, H, W XXXXXXXXXX	PRL0 [R/W] B, H, W XXXXXXXXXX	PRLH1 [R/W] B, H, W XXXXXXXXXX	PRL1 [R/W] B, H, W XXXXXXXXXX	PPG 0 to PPG F
000104 <sub>H</sub>	PRLH2 [R/W] B, H, W XXXXXXXXXX	PRL2 [R/W] B, H, W XXXXXXXXXX	PRLH3 [R/W] B, H, W XXXXXXXXXX	PRL3 [R/W] B, H, W XXXXXXXXXX	
000108 <sub>H</sub>	PPGC0 [R/W] B, H, W 0000000X	PPGC1 [R/W] B, H, W 0000000X	PPGC2 [R/W] B, H, W 0000000X	PPGC3 [R/W] B, H, W 0000000X	
00010C <sub>H</sub>	PRLH4 [R/W] B, H, W XXXXXXXXXX	PRL4 [R/W] B, H, W XXXXXXXXXX	PRLH5 [R/W] B, H, W XXXXXXXXXX	PRL5 [R/W] B, H, W XXXXXXXXXX	
000110 <sub>H</sub>	PRLH6 [R/W] B, H, W XXXXXXXXXX	PRL6 [R/W] B, H, W XXXXXXXXXX	PRLH7 [R/W] B, H, W XXXXXXXXXX	PRL7 [R/W] B, H, W XXXXXXXXXX	
000114 <sub>H</sub>	PPGC4 [R/W] B, H, W 0000000X	PPGC5 [R/W] B, H, W 0000000X	PPGC6 [R/W] B, H, W 0000000X	PPGC7 [R/W] B, H, W 0000000X	
000118 <sub>H</sub>	PRLH8 [R/W] B, H, W XXXXXXXXXX	PRL8 [R/W] B, H, W XXXXXXXXXX	PRLH9 [R/W] B, H, W XXXXXXXXXX	PRL9 [R/W] B, H, W XXXXXXXXXX	
00011C <sub>H</sub>	PRLHA [R/W] B, H, W XXXXXXXXXX	PRLA [R/W] B, H, W XXXXXXXXXX	PRLHB [R/W] B, H, W XXXXXXXXXX	PRLB [R/W] B, H, W XXXXXXXXXX	
000120 <sub>H</sub>	PPGC8 [R/W] B, H, W 0000000X	PPGC9 [R/W] B, H, W 0000000X	PPGCA [R/W] B, H, W 0000000X	PPGCB [R/W] B, H, W 0000000X	
000124 <sub>H</sub>	PRLHC [R/W] B, H, W XXXXXXXXXX	PRLC [R/W] B, H, W XXXXXXXXXX	PRLHD [R/W] B, H, W XXXXXXXXXX	PRLD [R/W] B, H, W XXXXXXXXXX	
000128 <sub>H</sub>	PRLHE [R/W] B, H, W XXXXXXXXXX	PRLLE [R/W] B, H, W XXXXXXXXXX	PRLHF [R/W] B, H, W XXXXXXXXXX	PRLF [R/W] B, H, W XXXXXXXXXX	
00012C <sub>H</sub>	PPGCC [R/W] B, H, W 0000000X	PPGCD [R/W] B, H, W 0000000X	PPGCE [R/W] B, H, W 0000000X	PPGCF [R/W] B, H, W 0000000X	

(Continued)

# MB91345 Series

Address	Register				Block
	0	1	2	3	
000130 <sub>H</sub>	PPGTRG [R/W] B, H, W 00000000 00000000		—	PPGGATEC [R/W] B XXXXXX00	PPG 0-F
000134 <sub>H</sub>	PPGREVC [R/W] B, H, W 00000000 00000000		—		
000138 <sub>H</sub> to 00014C <sub>H</sub>	—				Reserved
000150 <sub>H</sub>	CPCLRB/CPCLR [R/W] W 11111111 11111111 11111111 11111111				32 bit Free Run Timer 0
000154 <sub>H</sub>	TCDT [R/W] W 00000000 00000000 00000000 00000000				
000158 <sub>H</sub>	TCCSH [R/W] B 00000000	TCCSL [R/W] B 01000000	—		32 bit Input Capture Unit 4 to 7
00015C <sub>H</sub>	IPCP4 [R] W XXXXXXXX XXXXXXXX XXXXXXXX XXXXXXXX				
000160 <sub>H</sub>	IPCP5 [R] W XXXXXXXX XXXXXXXX XXXXXXXX XXXXXXXX				
000164 <sub>H</sub>	IPCP6 [R] W XXXXXXXX XXXXXXXX XXXXXXXX XXXXXXXX				
000168 <sub>H</sub>	IPCP7 [R] W XXXXXXXX XXXXXXXX XXXXXXXX XXXXXXXX				
00016C <sub>H</sub>	—	ICS45 [R/W] 00000000	—	ICS67 [R/W] 00000000	
000170 <sub>H</sub>	OCCP4 [R/W] W XXXXXXXX XXXXXXXX XXXXXXXX XXXXXXXX				
000174 <sub>H</sub>	OCCP5 [R/W] W XXXXXXXX XXXXXXXX XXXXXXXX XXXXXXXX				
000178 <sub>H</sub>	OCCP6 [R/W] W XXXXXXXX XXXXXXXX XXXXXXXX XXXXXXXX				
00017C <sub>H</sub>	OCCP7 [R/W] W XXXXXXXX XXXXXXXX XXXXXXXX XXXXXXXX				
000180 <sub>H</sub>	OCS45 [R/W] 11101100 00001100		OCS67 [R/W] 11101100 00001100		
000184 <sub>H</sub>	RCRH1 [W] B, H 00000000	RCRL0 [W] B, H 00000000	UDCR1 [R] B, H 00000000	UDCR0 [R] B, H 00000000	Up/Down Counter 0, 1
000188 <sub>H</sub>	CCRHO [R/W] B, H 00000000	CCRL0 [R/W] B, H 00000000	—	CSR0 [R/W] B 00000000	
00018C <sub>H</sub>	CCRHI [R/W] B, H 00000000	CCRL1 [R/W] B, H 00000000	—	CSR1 [R/W] B 00000000	

(Continued)

# MB91345 Series

Address	Register				Block
	0	1	2	3	
000190H	—				Reserved
000194H	RCRH3 [W] B, H 00000000	RCRL2 [W] B, H 00000000	UDCR3 [R] B, H 00000000	UDCR2 [R] B, H 00000000	Up/Down Counter 2, 3
000198H	CCRH2 [R/W] B, H 00000000	CCRL2 [R/W] B, H 00000000	—	CSR2 [R/W] B 00000000	
00019CH	CCRH3 [R/W] B, H 00000000	CCRL3 [R/W] B, H 00000000	—	CSR3 [R/W] B 00000000	
0001A0H to 0001ACH	—				Reserved
0001B0H	SCR6/IBCR6 [R, R/W] *	SMR6 [W, R/W] *	SSR6 [R, R/W] *	ESCR6/IBSR6 [R/W] *	Multi function Serial Interface 6
0001B4H	RDR6/TDR6 [R/W] *		BGR61 [R/W] *	BGR60 [R/W] *	
0001B8H	ISMK6 [R/W] *	IBSA6 [R/W] *	—		
0001BCH	—				
0001C0H	SCR7/IBCR7 [R, R/W] *	SMR7 [W, R/W] *	SSR7 [R, R/W] *	ESCR7/IBSR7 [R/W] *	Multi function Serial Interface 7
0001C4H	RDR7/TDR7 [R/W] *		BGR71 [R/W] *	BGR70 [R/W] *	
0001C8H	ISMK7 [R/W] *	IBSA7 [R/W] *	—		
0001CCH	—				
0001D0H	SCR8/IBCR8 [R, R/W] *	SMR8 [W, R/W] *	SSR8 [R, R/W] *	ESCR8/IBSR8 [R/W] *	Multi function Serial Interface 8
0001D4H	RDR8/TDR8 [R/W] *		BGR81 [R/W] *	BGR80 [R/W] *	
0001D8H	ISMK8 [R/W] *	IBSA8 [R/W] *	—		
0001DCH	—				

(Continued)

# MB91345 Series

Address	Register				Block	
	0	1	2	3		
0001E0H	SCR9/IBCR9 [R, R/W] *	SMR9 [W, R/W] *	SSR9 [R, R/W] *	ESCR9/IBSR9 [R/W] *	Multi function Serial Interface 9	
0001E4H	RDR9/TDR9 [R/W] *		BGR91 [R/W] *	BGR90 [R/W] *		
0001E8H	ISMK9 [R/W] *	IBSA9 [R/W] *	—			
0001ECH	—					
0001F0H	SCRA/IBCRA [R, R/W] *	SMRA [W, R/W] *	SSRA [R, R/W] *	ESCRA/IBSRA [R/W] *	Multi function Serial Interface 10	
0001F4H	RDRA/TDRA [R/W] *		BGRA1 [R/W] *	BGRA0 [R/W] *		
0001F8H	ISMKA [R/W] *	IBSAA [R/W] *	—			
0001FCH	—					
000200H	DMACA0 [R/W] 00000000 00000000 00000000 00000000				DMAC	
000204H	DMACB0 [R/W] 00000000 00000000 00000000 00000000					
000208H	DMACA1 [R/W] 00000000 00000000 00000000 00000000					
00020CH	DMACB1 [R/W] 00000000 00000000 00000000 00000000					
000210H	DMACA2 [R/W] 00000000 00000000 00000000 00000000					
000214H	DMACB2 [R/W] 00000000 00000000 00000000 00000000					
000218H	DMACA3 [R/W] 00000000 00000000 00000000 00000000					
00021CH	DMACB3 [R/W] 00000000 00000000 00000000 00000000					
000220H	DMACA4 [R/W] 00000000 00000000 00000000 00000000					
000224H	DMACB4 [R/W] 00000000 00000000 00000000 00000000					
000228H to 00023CH	—					Reserved
000240H	DMACR [R/W] 0XX00000 XXXXXXXX XXXXXXXX XXXXXXXX					DMAC

(Continued)

# MB91345 Series

Address	Register				Block
	0	1	2	3	
000244 <sub>H</sub> to 0003BC <sub>H</sub>	—				Reserved
0003A0 <sub>H</sub>	DATA_A [-/W] XXXXXXXX XXXXXXXX XXXXXXXX XXXXXXXX				MIN/MAX/ABS
0003A4 <sub>H</sub>	DATA_B [-/W] XXXXXXXX XXXXXXXX XXXXXXXX XXXXXXXX				
0003A8 <sub>H</sub>	MIN [R/W] 00000000 00000000 00000000 00000000				
0003AC <sub>H</sub>	MAX [R/W] 00000000 00000000 00000000 00000000				
0003B0 <sub>H</sub>	ABS [R/W] 00000000 00000000 00000000 00000000				
0003B4 <sub>H</sub> to 0003EC <sub>H</sub>	—				Reserved
0003F0 <sub>H</sub>	BSD0 [W] XXXXXXXX XXXXXXXX XXXXXXXX XXXXXXXX				Bit Search
0003F4 <sub>H</sub>	BSD1 [R/W] XXXXXXXX XXXXXXXX XXXXXXXX XXXXXXXX				
0003F8 <sub>H</sub>	BSDC [W] XXXXXXXX XXXXXXXX XXXXXXXX XXXXXXXX				
0003FC <sub>H</sub>	BSRR [R] XXXXXXXX XXXXXXXX XXXXXXXX XXXXXXXX				
000400 <sub>H</sub>	DDR0 [R/W] B, H 00000000	DDR1 [R/W] B, H 00000000	DDR2 [R/W] B, H 00000000	DDR3 [R/W] B, H 00000000	Data Direction Registers
000404 <sub>H</sub>	DDR4 [R/W] B, H 00000000	DDR5 [R/W] B, H 00000000	DDR6 [R/W] B, H ----0000	—	
000408 <sub>H</sub>	—				
00040C <sub>H</sub>	DDRC [R/W] B, H -----000	DDRD [R/W] B, H 00000000	DDRE [R/W] B, H 00000000	—	
000410 <sub>H</sub>	—				
000414 <sub>H</sub> to 00041C <sub>H</sub>	—				Reserved

(Continued)

# MB91345 Series

Address	Register				Block
	0	1	2	3	
000420 <sub>H</sub>	PFR0 [R/W] B, H 00000000	PFR1 [R/W] B, H 00000000	PFR2 [R/W] B, H 00000000	PFR3 [R/W] B, H 00000000	Port Function Register
000424 <sub>H</sub>	PFR4 [R/W] B, H 00000000	PFR5 [R/W] B, H 00000000	PFR6 [R/W] B, H ----0000	—	
000428 <sub>H</sub>	—				
00042C <sub>H</sub>	PFRC [R/W] B, H ----000	PFRD [R/W] B, H 00000000	PFRE [R/W] B, H 00000000	—	
000430 <sub>H</sub> to 00043C <sub>H</sub>	—				Reserved
000440 <sub>H</sub>	ICR00 [R, R/W] ---11111	ICR01 [R, R/W] ---11111	ICR02 [R, R/W] ---11111	ICR03 [R, R/W] ---11111	Interrupt Control Register
000444 <sub>H</sub>	ICR04 [R, R/W] ---11111	ICR05 [R, R/W] ---11111	ICR06 [R, R/W] ---11111	ICR07 [R, R/W] ---11111	
000448 <sub>H</sub>	ICR08 [R, R/W] ---11111	ICR09 [R, R/W] ---11111	ICR10 [R, R/W] ---11111	ICR11 [R, R/W] ---11111	
00044C <sub>H</sub>	ICR12 [R, R/W] ---11111	ICR13 [R, R/W] ---11111	ICR14 [R, R/W] ---11111	ICR15 [R, R/W] ---11111	
000450 <sub>H</sub>	ICR16 [R, R/W] ---11111	ICR17 [R, R/W] ---11111	ICR18 [R, R/W] ---11111	ICR19 [R, R/W] ---11111	
000454 <sub>H</sub>	ICR20 [R, R/W] ---11111	ICR21 [R, R/W] ---11111	ICR22 [R, R/W] ---11111	ICR23 [R, R/W] ---11111	
000458 <sub>H</sub>	ICR24 [R, R/W] ---11111	ICR25 [R, R/W] ---11111	ICR26 [R, R/W] ---11111	ICR27 [R, R/W] ---11111	
00045C <sub>H</sub>	ICR28 [R, R/W] ---11111	ICR29 [R, R/W] ---11111	ICR30 [R, R/W] ---11111	ICR31 [R, R/W] ---11111	
000460 <sub>H</sub>	ICR32 [R, R/W] ---11111	ICR33 [R, R/W] ---11111	ICR34 [R, R/W] ---11111	ICR35 [R, R/W] ---11111	
000464 <sub>H</sub>	ICR36 [R, R/W] ---11111	ICR37 [R, R/W] ---11111	ICR38 [R, R/W] ---11111	ICR39 [R, R/W] ---11111	
000468 <sub>H</sub>	ICR40 [R, R/W] ---11111	ICR41 [R, R/W] ---11111	ICR42 [R, R/W] ---11111	ICR43 [R, R/W] ---11111	
00046C <sub>H</sub>	ICR44 [R, R/W] ---11111	ICR45 [R, R/W] ---11111	ICR46 [R, R/W] ---11111	ICR47 [R, R/W] ---11111	
000470 <sub>H</sub> to 00047C <sub>H</sub>	—				

(Continued)

# MB91345 Series

Address	Register				Block
	0	1	2	3	
000480 <sub>H</sub>	RSRR [R, R/W] 10000000	STCR [R/W] 00110011	TBCR [R/W] 00XXXX00	CTBR [W] XXXXXXXXXX	Clock Control Unit
000484 <sub>H</sub>	CLKR [R/W] 00000000	WPR [W] XXXXXXXXXX	DIVR0 [R/W] 00000011	DIVR1 [R/W] 00000000	
000488 <sub>H</sub>	—		OSCCR [R/W] XXXXXXXXXX	—	
00048C <sub>H</sub>	—				Reserved
000490 <sub>H</sub>	OSCR [R/W] 00000000	OSCT [R/W] XXXXXXXXXX	—		Stb. Wait Timer
000494 <sub>H</sub> to 0004FC <sub>H</sub>	—				Reserved
000500 <sub>H</sub>	PCR0 [R/W] B, H 00000000	PCR1 [R/W] B, H 00000000	—		Pull-up Control Registers
000504 <sub>H</sub>	—	PCR5 [R/W] B, H 00000000	PCR6 [R/W] B, H ----0000	—	
000508 <sub>H</sub>	—				
00050C <sub>H</sub>	PCRC [R/W] B, H ----000	PCRD [R/W] B, H 00000000	PCRE [R/W] B, H 00000000	—	
000510 <sub>H</sub>	—				Reserved
000514 <sub>H</sub> to 00051C <sub>H</sub>	—				
000520 <sub>H</sub>	EPFR0 [R/W] B, H 00000000	EPFR1 [R/W] B, H 00000000	EPFR2 [R/W] B, H 11111111	EPFR3 [R/W] B, H 11111111	
000524 <sub>H</sub>	EPFR4 [R/W] B, H 11111111	EPFR5 [R/W] B, H 11111111	EPFR6 [R/W] B, H ----1000	—	Extra Port Function Registers
000528 <sub>H</sub>	—				
00052C <sub>H</sub>	EPFRC [R/W] B, H ----000	EPFRD [R/W] B, H 00000000	EPFRE [R/W] B, H 00000000	—	
000530 <sub>H</sub>	—				Reserved
000534 <sub>H</sub> to 000550 <sub>H</sub>	—				

(Continued)

# MB91345 Series

Address	Register				Block
	0	1	2	3	
000554 <sub>H</sub>	TTCR0 [R/W] B, H, W 11110000	—		TSTPR0 [R] B, H, W 00000000	Timing Generator
000558 <sub>H</sub>	COMP0 [R/W] B, H, W 00000000	COMP2 [R/W] B, H, W 00000000	COMP4 [R/W] B, H, W 00000000	COMP6 [R/W] B, H, W 00000000	
00055C <sub>H</sub>	TTCR1 [R/W] B, H, W 11110000	—		TSTPR1 [R] B, H, W 00000000	
000560 <sub>H</sub>	COMP8 [R/W] B, H, W 00000000	COMP10 [R/W] B, H, W 00000000	COMP12 [R/W] B, H, W 00000000	COMP14 [R/W] B, H, W 00000000	
000564 <sub>H</sub> to 000574 <sub>H</sub>	—				Reserved
000578 <sub>H</sub>	ADTGS [R/W] B -----00	—			AD Trigger Select
00057C <sub>H</sub> to 00063C <sub>H</sub>	—				Reserved
000640 <sub>H</sub> to 0007F8 <sub>H</sub>	—				Not Used
0007FC <sub>H</sub>	—	MODR [W] XXXXXXXX	—		Mode Register
000800 <sub>H</sub> to 000AFC <sub>H</sub>	—				Not Used
000B00 <sub>H</sub>	ESTS0 [R/W] B X0000000	ESTS1 [R/W] B XXXXXXXX	ESTS2 [R] B 1XXXXXXXX	—	DSU (Evaluation Chip Only)
000B04 <sub>H</sub>	ECTL0 [R/W] B 0X000000	ECTL1 [R/W] B 00000000	ECTL2 [W] B 000X0000	ECTL3 [R/W] B 00X00X11	
000B08 <sub>H</sub>	ECNT0 [W] B XXXXXXXX	ECNT1 [W] B XXXXXXXX	EUSA [W] B XXX00000	EDTC [W] B 0000XXXX	
000B0C <sub>H</sub>	EWPT [R] H 00000000 00000000		ECTL4 [R] ([R/W]) B -0X00000	ECTL5 [R] ([R/W]) B ----000X	
000B10 <sub>H</sub>	EDTR0 [W] H XXXXXXXXXX XXXXXXXXX		EDTR1 [W] H XXXXXXXXXX XXXXXXXXX		
000B14 <sub>H</sub> to 000B1C <sub>H</sub>	—				

(Continued)

# MB91345 Series

Address	Register				Block
	0	1	2	3	
000B20 <sub>H</sub>	EIA0 [W] W XXXXXXXX XXXXXXXX XXXXXXXX XXXXXXXX				DSU (Evaluation Chip Only)
000B24 <sub>H</sub>	EIA1 [W] W XXXXXXXX XXXXXXXX XXXXXXXX XXXXXXXX				
000B28 <sub>H</sub>	EIA2 [W] W XXXXXXXX XXXXXXXX XXXXXXXX XXXXXXXX				
000B2C <sub>H</sub>	EIA3 [W] W XXXXXXXX XXXXXXXX XXXXXXXX XXXXXXXX				
000B30 <sub>H</sub>	EIA4 [W] W XXXXXXXX XXXXXXXX XXXXXXXX XXXXXXXX				
000B34 <sub>H</sub>	EIA5 [W] W XXXXXXXX XXXXXXXX XXXXXXXX XXXXXXXX				
000B38 <sub>H</sub>	EIA6 [W] W XXXXXXXX XXXXXXXX XXXXXXXX XXXXXXXX				
000B3C <sub>H</sub>	EIA7 [W] W XXXXXXXX XXXXXXXX XXXXXXXX XXXXXXXX				
000B40 <sub>H</sub>	EDTA [R/W] W XXXXXXXX XXXXXXXX XXXXXXXX XXXXXXXX				
000B44 <sub>H</sub>	EDTM [R/W] W XXXXXXXX XXXXXXXX XXXXXXXX XXXXXXXX				
000B48 <sub>H</sub>	EOA0 [W] W XXXXXXXX XXXXXXXX XXXXXXXX XXXXXXXX				
000B4C <sub>H</sub>	EOA1 [W] W XXXXXXXX XXXXXXXX XXXXXXXX XXXXXXXX				
000B50 <sub>H</sub>	EPCR [R/W] W XXXXXXXX XXXXXXXX XXXXXXXX XXXXXXXX				
000B54 <sub>H</sub>	EPSR [R/W] XXXXXXXX XXXXXXXX XXXXXXXX XXXXXXXX				
000B58 <sub>H</sub>	EIAM0 [W] XXXXXXXX XXXXXXXX XXXXXXXX XXXXXXXX				
000B5C <sub>H</sub>	EIAM1 [W] XXXXXXXX XXXXXXXX XXXXXXXX XXXXXXXX				
000B60 <sub>H</sub>	EOAM0/EODM0 [W] XXXXXXXX XXXXXXXX XXXXXXXX XXXXXXXX				
000B64 <sub>H</sub>	EOAM1/EODM1 [W] XXXXXXXX XXXXXXXX XXXXXXXX XXXXXXXX				
000B68 <sub>H</sub>	EOD0 [W] XXXXXXXX XXXXXXXX XXXXXXXX XXXXXXXX				
000B6C <sub>H</sub>	EOD1 [W] XXXXXXXX XXXXXXXX XXXXXXXX XXXXXXXX				

(Continued)

# MB91345 Series

Address	Register				Block
	0	1	2	3	
000B70H to 000FFCH	—				Reserved
001000H	DMASA0 [R/W] 00000000 00000000 00000000 00000000				DMAC
001004H	DMADA0 [R/W] 00000000 00000000 00000000 00000000				
001008H	DMASA1 [R/W] 00000000 00000000 00000000 00000000				
00100CH	DMADA1 [R/W] 00000000 00000000 00000000 00000000				
001010H	DMASA2 [R/W] 00000000 00000000 00000000 00000000				
001014H	DMADA2 [R/W] 00000000 00000000 00000000 00000000				
001018H	DMASA3 [R/W] 00000000 00000000 00000000 00000000				
00101CH	DMADA3 [R/W] 00000000 00000000 00000000 00000000				
001020H	DMASA4 [R/W] 00000000 00000000 00000000 00000000				
001024H	DMADA4 [R/W] 00000000 00000000 00000000 00000000				
001028H to 006FFCH	—				Reserved
007000H	FLCR [R/W] 01101000	—			Flash Interface
007004H	FLWC [R/W] 00110011	—			
007008H to 007019H	—				Reserved
007020H	WREN [R/W] 00000000	—			Wild Register Enable Register
007024H to 00702CH	—				Reserved

(Continued)

# MB91345 Series

(Continued)

Address	Register				Block
	0	1	2	3	
007030 <sub>H</sub>	WA0 [R/W] XXXXXXXX XXXXXXXX XXXXXXXX XXXXXXXX				Flash Interface
007034 <sub>H</sub>	WD0 [R/W] XXXXXXXX XXXXXXXX XXXXXXXX XXXXXXXX				
007038 <sub>H</sub>	WA1 [R/W] XXXXXXXX XXXXXXXX XXXXXXXX XXXXXXXX				
00703C <sub>H</sub>	WD1 [R/W] XXXXXXXX XXXXXXXX XXXXXXXX XXXXXXXX				
007040 <sub>H</sub>	WA2 [R/W] XXXXXXXX XXXXXXXX XXXXXXXX XXXXXXXX				
007044 <sub>H</sub>	WD2 [R/W] XXXXXXXX XXXXXXXX XXXXXXXX XXXXXXXX				
007048 <sub>H</sub>	WA3 [R/W] XXXXXXXX XXXXXXXX XXXXXXXX XXXXXXXX				Flash Interface
00704C <sub>H</sub>	WD3 [R/W] XXXXXXXX XXXXXXXX XXXXXXXX XXXXXXXX				
007050 <sub>H</sub>	WA4 [R/W] XXXXXXXX XXXXXXXX XXXXXXXX XXXXXXXX				
007054 <sub>H</sub>	WD4 [R/W] XXXXXXXX XXXXXXXX XXXXXXXX XXXXXXXX				
007058 <sub>H</sub>	WA5 [R/W] XXXXXXXX XXXXXXXX XXXXXXXX XXXXXXXX				
00705C <sub>H</sub>	WD5 [R/W] XXXXXXXX XXXXXXXX XXXXXXXX XXXXXXXX				
007060 <sub>H</sub>	WA6 [R/W] XXXXXXXX XXXXXXXX XXXXXXXX XXXXXXXX				
007064 <sub>H</sub>	WD6 [R/W] XXXXXXXX XXXXXXXX XXXXXXXX XXXXXXXX				
007068 <sub>H</sub>	WA7 [R/W] XXXXXXXX XXXXXXXX XXXXXXXX XXXXXXXX				Flash Interface
00706C <sub>H</sub>	WD7 [R/W] XXXXXXXX XXXXXXXX XXXXXXXX XXXXXXXX				

\* : Refer to "Hardware manual" for initial value.

# MB91345 Series

## ■ VECTOR TABLE

Interrupt factor	Interrupt No.		Interrupt level	Offset	Address of TBR default	DMA transfer	DMAC STOP factor	
	Decimal	Hexa-decimal						
Reset	0	00	—	3FC <sub>H</sub>	000FFFFC <sub>H</sub>	—	—	
Mode vector	1	01	—	3F8 <sub>H</sub>	000FFFF8 <sub>H</sub>	—		
System reserved	2	02	—	3F4 <sub>H</sub>	000FFFF4 <sub>H</sub>	—		
System reserved	3	03	—	3F0 <sub>H</sub>	000FFFF0 <sub>H</sub>	—		
System reserved	4	04	—	3EC <sub>H</sub>	000FFFE <sub>C</sub>	—		
System reserved	5	05	—	3E8 <sub>H</sub>	000FFFE8 <sub>H</sub>	—		
System reserved	6	06	—	3E4 <sub>H</sub>	000FFFE4 <sub>H</sub>	—		
Coprocessor absent trap	7	07	—	3E0 <sub>H</sub>	000FFFE0 <sub>H</sub>	—		
Coprocessor error trap	8	08	—	3DC <sub>H</sub>	000FFFD <sub>C</sub>	—		
INTE instruction	9	09	—	3D8 <sub>H</sub>	000FFFD8 <sub>H</sub>	—		
Instruction break exception	10	0A	—	3D4 <sub>H</sub>	000FFFD4 <sub>H</sub>	—		
Operand break trap	11	0B	—	3D0 <sub>H</sub>	000FFFD0 <sub>H</sub>	—		
Step trace trap	12	0C	—	3CC <sub>H</sub>	000FFFC <sub>C</sub>	—		
NMI request (tool)	13	0D	—	3C8 <sub>H</sub>	000FFFC8 <sub>H</sub>	—		
Undefined instruction exception	14	0E	—	3C4 <sub>H</sub>	000FFFC4 <sub>H</sub>	—		
NMI request	15	0F	15 (F <sub>H</sub> ) fixed	3C0 <sub>H</sub>	000FFFC0 <sub>H</sub>	—		
External interrupt 0	16	10	ICR00	3BC <sub>H</sub>	000FFFB <sub>C</sub>	—		
External interrupt 1	17	11	ICR01	3B8 <sub>H</sub>	000FFFB8 <sub>H</sub>	—		
External interrupt 2	18	12	ICR02	3B4 <sub>H</sub>	000FFFB4 <sub>H</sub>	—		
External interrupt 3	19	13	ICR03	3B0 <sub>H</sub>	000FFFB0 <sub>H</sub>	—		
External interrupt 4	20	14	ICR04	3AC <sub>H</sub>	000FFFA <sub>C</sub>	—		
External interrupt 5	21	15	ICR05	3A8 <sub>H</sub>	000FFFA8 <sub>H</sub>	—		
External interrupt 6	22	16	ICR06	3A4 <sub>H</sub>	000FFFA4 <sub>H</sub>	—		
External interrupt 7	23	17	ICR07	3A0 <sub>H</sub>	000FFFA0 <sub>H</sub>	—		
Reload timer 0	24	18	ICR08	39C <sub>H</sub>	000FFF9 <sub>C</sub>	○		
Reload timer 1	25	19	ICR09	398 <sub>H</sub>	000FFF98 <sub>H</sub>	○		
Reload timer 2	26	1A	ICR10	394 <sub>H</sub>	000FFF94 <sub>H</sub>	○		
UART0 RX/I <sup>2</sup> C0 status	27	1B	ICR11	390 <sub>H</sub>	000FFF90 <sub>H</sub>	○		STOP
UART0 TX	28	1C	ICR12	38C <sub>H</sub>	000FFF8 <sub>C</sub>	○		—
UART1 RX/I <sup>2</sup> C1 status	29	1D	ICR13	388 <sub>H</sub>	000FFF88 <sub>H</sub>	○		STOP
UART1 TX	30	1E	ICR14	384 <sub>H</sub>	000FFF84 <sub>H</sub>	○		—
UART2 RX/I <sup>2</sup> C2 status	31	1F	ICR15	380 <sub>H</sub>	000FFF80 <sub>H</sub>	○		STOP
UART2 TX	32	20	ICR16	37C <sub>H</sub>	000FFF7 <sub>C</sub>	○	—	

(Continued)

# MB91345 Series

Interrupt factor	Interrupt No.		Interrupt level	Offset	Address of TBR default	DMA transfer	DMAC STOP factor
	Decimal	Hexa-decimal					
UART3 RX/TX/SX	33	21	ICR17	378 <sub>H</sub>	000FFF78 <sub>H</sub>	—	—
UART4 RX/TX/SX	34	22	ICR18	374 <sub>H</sub>	000FFF74 <sub>H</sub>	—	
UART5 RX/TX/SX	35	23	ICR19	370 <sub>H</sub>	000FFF70 <sub>H</sub>	—	
UART6 RX/TX/SX	36	24	ICR20	36C <sub>H</sub>	000FFF6C <sub>H</sub>	—	
UART7 RX/TX/SX	37	25	ICR21	368 <sub>H</sub>	000FFF68 <sub>H</sub>	—	
UART8 RX/TX/SX	38	26	ICR22	364 <sub>H</sub>	000FFF64 <sub>H</sub>	—	
UART9 RX/TX/SX	39	27	ICR23	360 <sub>H</sub>	000FFF60 <sub>H</sub>	—	
UART10 RX/TX/SX	40	28	ICR24	35C <sub>H</sub>	000FFF5C <sub>H</sub>	—	
A/D Converter 0	41	29	ICR25	358 <sub>H</sub>	000FFF58 <sub>H</sub>	○	
A/D Converter 1	42	2A	ICR26	354 <sub>H</sub>	000FFF54 <sub>H</sub>	○	
PWC (measurement completed, overflow)	43	2B	ICR27	350 <sub>H</sub>	000FFF50 <sub>H</sub>	—	
System reserved	44	2C	ICR28	34C <sub>H</sub>	000FFF4C <sub>H</sub>	—	
Up/Down Counter 1	45	2D	ICR29	348 <sub>H</sub>	000FFF48 <sub>H</sub>	—	
Up/Down Counter 2, 3	46	2E	ICR30	344 <sub>H</sub>	000FFF44 <sub>H</sub>	—	
Timebase Timer Overflow	47	2F	ICR31	340 <sub>H</sub>	000FFF40 <sub>H</sub>	—	
PPG 0/PPG 1/PPG 4/PPG 5	48	30	ICR32	33C <sub>H</sub>	000FFF3C <sub>H</sub>	—	
PPG 2/PPG 3/PPG 6/PPG 7	49	31	ICR33	338 <sub>H</sub>	000FFF38 <sub>H</sub>	—	
PPG 8/PPG 9/PPG C/PPG D	50	32	ICR34	334 <sub>H</sub>	000FFF34 <sub>H</sub>	—	
PPG A/PPG B/PPG E/PPG F	51	33	ICR35	330 <sub>H</sub>	000FFF30 <sub>H</sub>	—	
Free-run Timer 0	52	34	ICR36	32C <sub>H</sub>	000FFF2C <sub>H</sub>	—	
Free-run Timer 1	53	35	ICR37	328 <sub>H</sub>	000FFF28 <sub>H</sub>	—	
Input Capture 0/ Input Capture 1/ Input Capture 2/ Input Capture 3	54	36	ICR38	324 <sub>H</sub>	000FFF24 <sub>H</sub>	—	
Input Capture 4/ Input Capture 5/ Input Capture 6/ Input Capture 7	55	37	ICR39	320 <sub>H</sub>	000FFF20 <sub>H</sub>	—	
Output Compare 0/ Output Compare 1/ Output Compare 2/ Output Compare 3	56	38	ICR40	31C <sub>H</sub>	000FFF1C <sub>H</sub>	—	
Output Compare 4/ Output Compare 5/ Output Compare 6/ Output Compare 7	57	39	ICR41	318 <sub>H</sub>	000FFF18 <sub>H</sub>	—	

(Continued)

# MB91345 Series

(Continued)

Interrupt factor	Interrupt No.		Interrupt level	Offset	Address of TBR default	DMA transfer	DMAC STOP factor
	Decimal	Hexadecimal					
System reserved	58	3A	ICR42	314 <sub>H</sub>	000FFF14 <sub>H</sub>	—	—
External interrupt 8 to External interrupt 15	59	3B	ICR43	310 <sub>H</sub>	000FFF10 <sub>H</sub>	—	
External interrupt 16 to External interrupt 23	60	3C	ICR44	30C <sub>H</sub>	000FFF0C <sub>H</sub>	—	
Up/Down Counter 0	61	3D	ICR45	308 <sub>H</sub>	000FFF08 <sub>H</sub>	—	
DMA (0 channel to 4 channels)	62	3E	ICR46	304 <sub>H</sub>	000FFF04 <sub>H</sub>	—	
Delayed interrupt activation	63	3F	ICR47	300 <sub>H</sub>	000FFF00 <sub>H</sub>	—	
System reserved (Used by REALOS)	64	40	—	2FC <sub>H</sub>	000FFEFC <sub>H</sub>	—	
System reserved (Used by REALOS)	65	41	—	2F8 <sub>H</sub>	000FFE8 <sub>H</sub>	—	
System reserved	66	42	—	2F4 <sub>H</sub>	000FFE4 <sub>H</sub>	—	
System reserved	67	43	—	2F0 <sub>H</sub>	000FEF0 <sub>H</sub>	—	
System reserved	68	44	—	2EC <sub>H</sub>	000FEFEC <sub>H</sub>	—	
System reserved	69	45	—	2E8 <sub>H</sub>	000FEF8 <sub>H</sub>	—	
System reserved	70	46	—	2E4 <sub>H</sub>	000FEF4 <sub>H</sub>	—	
System reserved	71	47	—	2E0 <sub>H</sub>	000FEF0 <sub>H</sub>	—	
System reserved	72	48	—	2DC <sub>H</sub>	000FEDC <sub>H</sub>	—	
System reserved	73	49	—	2D8 <sub>H</sub>	000FED8 <sub>H</sub>	—	
System reserved	74	4A	—	2D4 <sub>H</sub>	000FED4 <sub>H</sub>	—	
System reserved	75	4B	—	2D0 <sub>H</sub>	000FED0 <sub>H</sub>	—	
System reserved	76	4C	—	2CC <sub>H</sub>	000FECC <sub>H</sub>	—	
System reserved	77	4D	—	2C8 <sub>H</sub>	000FEC8 <sub>H</sub>	—	
System reserved	78	4E	—	2C4 <sub>H</sub>	000FEC4 <sub>H</sub>	—	
System reserved	79	4F	—	2C0 <sub>H</sub>	000FEC0 <sub>H</sub>	—	
Used by INT instruction	80 to 255	50 to FF	—	2BC <sub>H</sub> to 000 <sub>H</sub>	000FEBC <sub>H</sub> to 000FC00 <sub>H</sub>	—	

## ■ ELECTRICAL CHARACTERISTICS

### 1. Absolute Maximum Rating

Parameter	Symbol	Rating		Unit
		Min	Max	
Power supply voltage *	$V_{CC}$	$V_{SS}-0.5$	$V_{SS} + 4.0$	V
Analog power supply voltage *	$AV_{CC}$	$V_{SS}-0.3$	$V_{SS} + 4.0$	V
Input voltage *	$V_I$	$V_{SS}-0.3$	$V_{SS} + 4.0$	V
Analog pin input voltage *	$V_{IA}$	$V_{SS}-0.3$	$AV_{CC} + 0.5$	V
Storage temperature	$T_{stg}$	-40	+125	°C

\* : The parameter is based on  $V_{SS} = AV_{SS} = 0.0$  V.

WARNING: Semiconductor devices can be permanently damaged by application of stress (voltage, current, temperature, etc.) in excess of absolute maximum ratings. Do not exceed these ratings.

### 2. Recommended Operating Conditions

( $V_{SS} = AV_{SS} = 0$  V)

Parameter	Symbol	Value		Unit
		Min	Max	
Operating temperature	$T_a$	- 40	+ 85	°C
Power supply voltage	$V_{CC}$	3.0	3.6	V
Analog power supply voltage	$AV_{CC}$	3.0	$V_{CC}$	V

WARNING: The recommended operating conditions are required in order to ensure the normal operation of the semiconductor device. All of the device's electrical characteristics are warranted when the device is operated within these ranges.

Always use semiconductor devices within their recommended operating condition ranges. Operation outside these ranges may adversely affect reliability and could result in device failure.

No warranty is made with respect to uses, operating conditions, or combinations not represented on the data sheet. Users considering application outside the listed conditions are advised to contact their representatives beforehand.

# MB91345 Series

## 3. DC Characteristics

( $V_{CC} = AV_{CC} = 3.0\text{ V to }3.6\text{ V}$ ,  $V_{SS} = AV_{SS} = 0\text{ V}$ ,  $T_a = -40\text{ }^\circ\text{C to }+85\text{ }^\circ\text{C}$ )

Parameter	Symbol	Pin name	Conditions	Value			Unit	Remarks
				Min	Typ	Max		
Power supply current	$I_{CC}$	VCC	During normal operation $T_a = +25\text{ }^\circ\text{C}$ $f_{cp} = 50\text{ MHz}$ , $f_{cpp} = 25\text{ MHz}$	—	65	80	mA	
	$I_{CCS}$		SLEEP mode during normal operation $T_a = +25\text{ }^\circ\text{C}$ $f_{cp} = 50\text{ MHz}$ , $f_{cpp} = 25\text{ MHz}$	—	30	35	mA	
	$I_{CCH}$		In STOP mode $T_a = +25\text{ }^\circ\text{C}$ , $f_{clk} = 0$	—	66	390	$\mu\text{A}$	
			In STOP mode $T_a = +45\text{ }^\circ\text{C}$ , $f_{clk} = 0$	—	140	760	$\mu\text{A}$	
"H" level input voltage	$V_{IH}$	—	—	$V_{CC} \times 0.7$	—	$V_{CC}$	V	P20 to P27, P30 to P37, P40 to P47
"L" level input voltage	$V_{IL}$	—	—	$V_{SS}$	—	$V_{CC} \times 0.3$	V	P20 to P27, P30 to P37, P40 to P47
"H" level input voltage	$V_{IH}$	—	—	$V_{CC} \times 0.8$	—	$V_{CC}$	V	
"L" level input voltage	$V_{IL}$	—	—	$V_{SS}$	—	$V_{CC} \times 0.2$	V	
"H" level output voltage	$V_{OH}$	—	$I_{OH} = -4\text{ mA}$	$V_{CC} - 0.5$	—	$V_{CC}$	V	
"L" level output voltage	$V_{OL}$	—	$I_{OL} = 4\text{ mA}$	$V_{SS}$	—	0.4	V	
Input leak current	$I_{IL}$	—	—	-5	—	+5	$\mu\text{A}$	
A/D power supply current (analog + digital)	—	—	—	—	7.2	—	mA	At operating A/D converter 2 units
	—	—	—	—	—	5	$\mu\text{A}$	At power down operation*
A/D reference power supply current (AVRH to $V_{SS}$ )	—	—	—	—	940	—	$\mu\text{A}$	At operating A/D converter 2 units AVRH = 3.0 V, $V_{SS} = 0.0\text{ V}$
	—	—	—	—	—	10	$\mu\text{A}$	At power down operation*

\* : Current when A/D converter is not operating and the CPU is in stop mode.

## 4. AC Characteristics

### (1) Main Clock Input Standard

( $V_{CC} = AV_{CC} = 3.0\text{ V to }3.6\text{ V}$ ,  $V_{SS} = AV_{SS} = 0\text{ V}$ ,  $T_a = -40\text{ }^\circ\text{C to }+85\text{ }^\circ\text{C}$ )

Parameter	Symbol	Pin name	Conditions	Value			Unit	Remarks
				Min	Typ	Max		
Clock frequency	$f_C$	X0	—	10	12.5	13	MHz	
Input clock cycle	$t_{CYL}$		—	—	80	—	ns	
Input clock pulse width	—		$P_{WH}/t_{CYL}$ $P_{WL}/t_{CYL}$	40	—	60	%	
Input clock rise time and fall time	$t_{CF}$ $t_{CR}$		—	—	—	5	ns	In external clock
Internal operating clock frequency	$f_{CP}$	—	—	—	—	50	MHz	CPU core operation clock
Peripheral clock cycle time	$t_{CYCP}$	—	—	40	—	—	ns	Peripheral clock is derived from internal operating clock divided by 1/1 to 1/16.

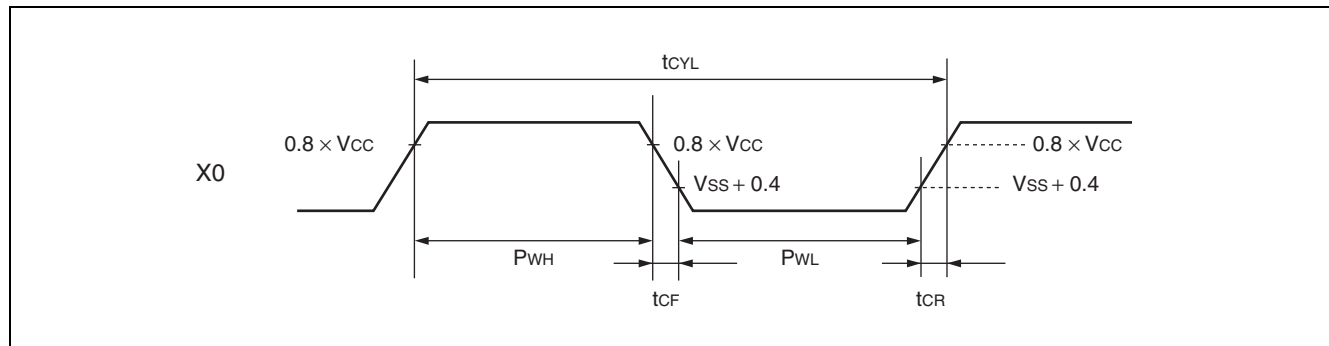

# MB91345 Series

## (2) PLL Oscillation Stabilization Wait Time (LOCK UP Time)

( $V_{CC} = AV_{CC} = 3.0\text{ V to }3.6\text{ V}$ ,  $V_{SS} = AV_{SS} = 0\text{ V}$ ,  $T_a = -40\text{ }^{\circ}\text{C to }+85\text{ }^{\circ}\text{C}$ )

Parameter	Symbol	Value		Unit	Remarks
		Min	Max		
PLL oscillation stabilization wait time (LOCK UP time)	$t_{LOCK}$	500	—	$\mu\text{s}$	Wait time until the PLL oscillation is stable.

## (3) Reset Input Standard

( $V_{CC} = AV_{CC} = 3.0\text{ V to }3.6\text{ V}$ ,  $V_{SS} = AV_{SS} = 0\text{ V}$ ,  $T_a = -40\text{ }^{\circ}\text{C to }+85\text{ }^{\circ}\text{C}$ )

Parameter	Symbol	Pin name	Conditions	Value		Unit	Remarks
				Min	Max		
Reset input time (except power-on)	$t_{INTL}$	$\overline{\text{INIT}}$	—	$t_{CP} \times 10$	—	ns	

Notes : •  $t_{CP}$  is cycle time for CPU operation clock (CLKB) .

- For power-on, input  $\overline{\text{INIT}} = \text{“L”}$  more than regulator voltage stabilization wait time. If the oscillation stabilization wait time of used oscillator takes more time than regulator voltage stabilization wait time, input  $\overline{\text{INIT}} = \text{“L”}$  until the oscillation is stable.

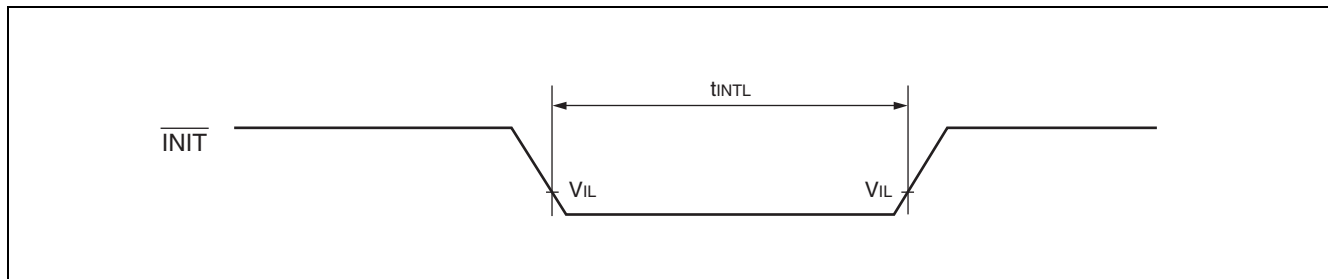

## (4) UART Timing

( $V_{CC} = AV_{CC} = 3.0\text{ V to }3.6\text{ V}$ ,  $V_{SS} = AV_{SS} = 0\text{ V}$ ,  $T_a = -40\text{ }^{\circ}\text{C to }+85\text{ }^{\circ}\text{C}$ )

Parameter	Symbol	Pin name	Conditions	Value		Unit
				Min	Max	
Serial clock cycle time	$t_{SCYC}$	SCK0 to SCK10	Internal shift clock operation	$4 t_{CYCP}$	—	ns
SCK ↓ → SOT delay time	$t_{SLOV}$	SCK0 to SCK10, SOT0 to SOT10		- 20	+ 20	ns
Valid SIN → SCK ↑	$t_{IVSH}$	SCK0 to SCK10, SIN0 to SIN10		30	—	ns
SCK ↑ → valid SIN hold time	$t_{SHIX}$	SCK0 to SCK10, SIN0 to SIN10		20	—	ns
Serial clock "H" pulse width	$t_{SHSL}$	SCK0 to SCK10	External shift clock operation	$2 t_{CYCP}$	—	ns
Serial clock "L" pulse width	$t_{LSLH}$	SCK0 to SCK10		$2 t_{CYCP}$	—	ns
SCK ↓ → SOT delay time	$t_{SLOV}$	SCK0 to SCK10, SOT0 to SOT10		—	30	ns
Valid SIN → SCK ↑	$t_{IVSH}$	SCK0 to SCK10, SIN0 to SIN10		20	—	ns
SCK ↑ → valid SIN hold time	$t_{SHIX}$	SCK0 to SCK10, SIN0 to SIN10		20	—	ns

Notes : • AC rating in CLK synchronous mode  
 •  $t_{CYCP}$  is the peripheral clock cycle time.

# MB91345 Series

- Internal shift clock mode

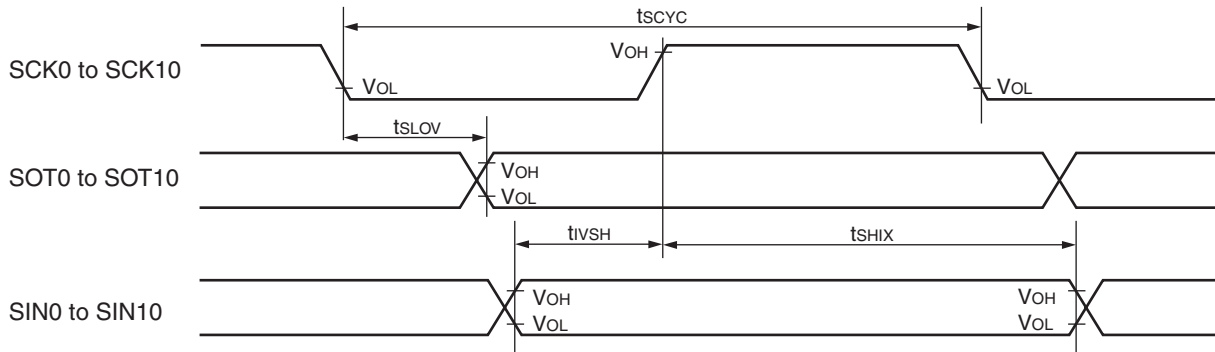

- External shift clock mode

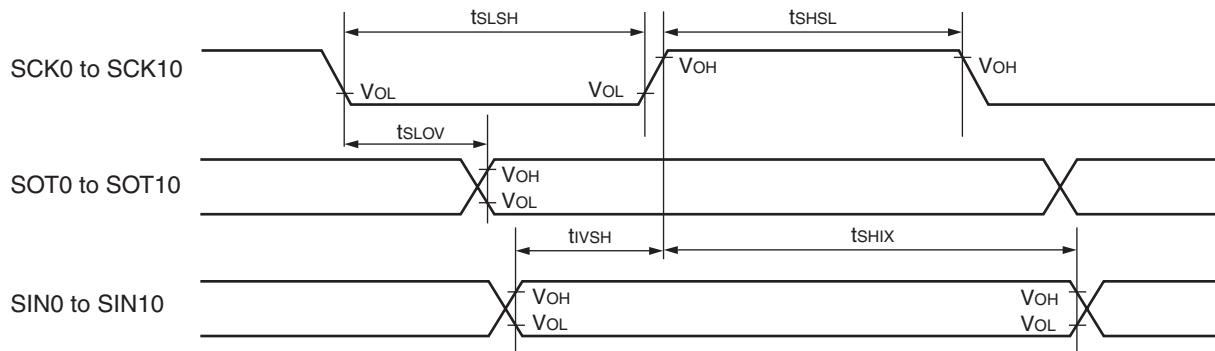

## (5) Free-run timer clock, Reload timer event Input , up down counter Input , Input capture Input, Interrupt Input Timing

( $V_{CC} = AV_{CC} = 3.0\text{ V to }3.6\text{ V}$ ,  $V_{SS} = AV_{SS} = 0\text{ V}$ ,  $T_a = -40\text{ }^{\circ}\text{C to }+85\text{ }^{\circ}\text{C}$ )

Parameter	Symbol	Pin name	Conditions	Value		Unit	Remarks
				Min	Max		
Input pulse width	$t_{TIWH}$ $t_{TIWL}$	FRCK0, FRCK1, TIN0 to TIN2, IC0, IC1, AIN0, AIN1, BIN0, BIN1, ZIN0, ZIN1	—	$t_{CYCP} \times 2$	—	ns	*1
		INT0 to INT23		$t_{CYCP} \times 3$	—	ns	*2
		1.0		—	$\mu\text{s}$	*3	

\*1 :  $t_{CYCP}$  is cycle time for peripheral clock.

\*2 : Except in stop time

\*3 : In stop time

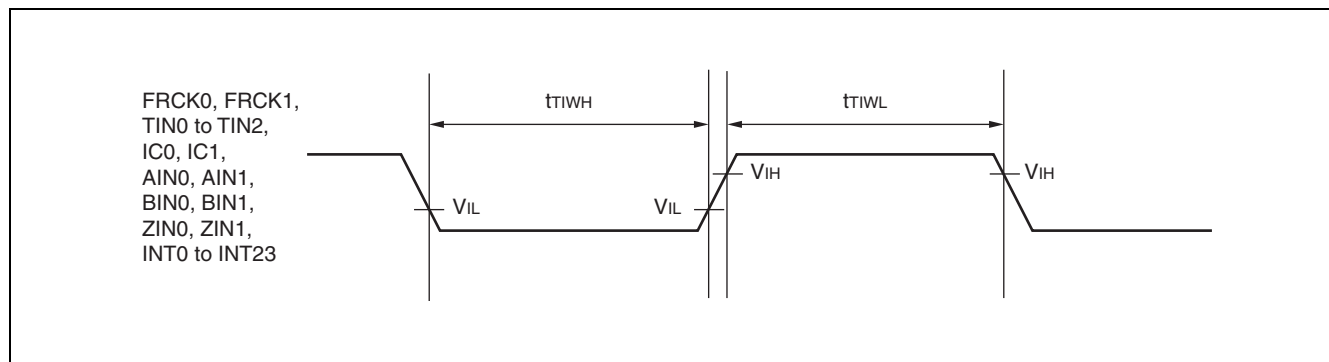

# MB91345 Series

## (6) A/D Converter Trigger Input Timing

( $V_{CC} = AV_{CC} = 3.0\text{ V to }3.6\text{ V}$ ,  $V_{SS} = AV_{SS} = 0\text{ V}$ ,  $T_a = -40\text{ }^{\circ}\text{C to }+85\text{ }^{\circ}\text{C}$ )

Parameter	Symbol	Pin name	Conditions	Value		Unit	Remarks
				Min	Max		
A/D converter trigger input (falling time)	$t_{\text{TADTG}}$	ADTRG0, ADTRG0-2, ADTRG1, ADTRG1-2	—	$t_{\text{CYCP}} \times 2$	—	ns	*

\* :  $t_{\text{CYCP}}$  is the peripheral clock cycle time.

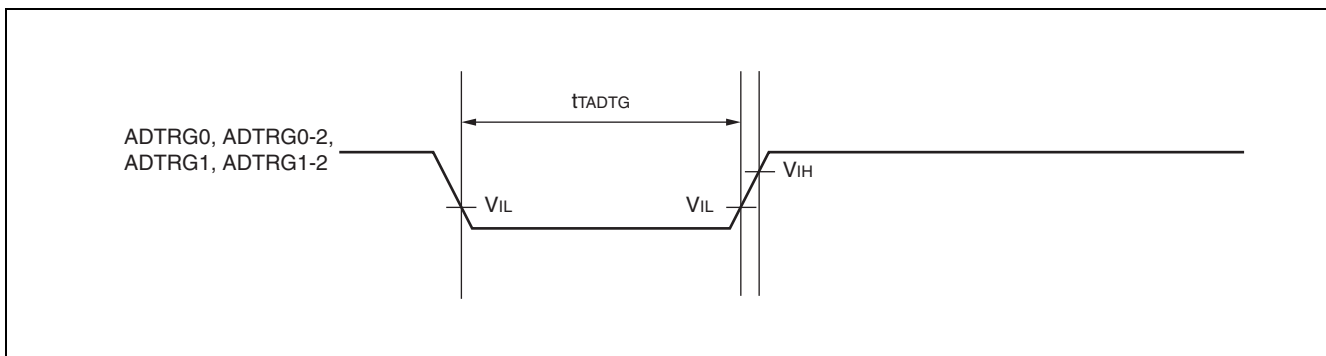

## (7) I<sup>2</sup>C timing

- At master mode operating

(V<sub>CC</sub> = AV<sub>CC</sub> = 3.0 V to 3.6 V, V<sub>SS</sub> = AV<sub>SS</sub> = 0 V, Ta = -40 °C to +85 °C)

Parameter	Symbol	Pin name	Conditions	Typical mode		High-speed mode* <sup>3</sup>		Unit	Remarks
				Min	Max	Min	Max		
SCL clock frequency	f <sub>SCL</sub>	SDA0 to SDA10, SCL0 to SCL10	R = 1 kΩ C = 50 pF <sup>4</sup>	0	100	0	400	kHz	
“L” period of SCL clock	t <sub>LOW</sub>			4.7	—	1.3	—	μs	
“H” period of SCL clock	t <sub>HIGH</sub>			4.0	—	0.6	—	μs	
SCL↓ → SDA output delay time	t <sub>DLDAT</sub>			—	5 × M <sup>1</sup>	—	5 × M <sup>1</sup>	ns	
Bus free time between [STOP condition] and [START condition]	t <sub>BUS</sub>			4.7	—	1.3	—	μs	
SDA data input hold time (vs. SCL↓)	t <sub>HDDAT</sub>			2 × M <sup>1</sup>	—	2 × M <sup>1</sup>	—	μs	
SDA data input setup time (vs. SCL↑)	t <sub>SUDAT</sub>			250	—	100 <sup>2</sup>	—	ns	
Setup time of [repeat START condition] SCL↑ → SDA↓	t <sub>SUSTA</sub>			4.7	—	0.6	—	μs	
Hold time of [repeat START condition] SDA↓ → SCL↓	t <sub>HDSTA</sub>			4.0	—	0.6	—	μs	After that, the first clock pulse is generated.
Setup time of [STOP condition] SCL↑ → SDA↑	t <sub>SUSTO</sub>			4.0	—	0.6	—	μs	

\*1 : M = Resource clock cycle (ns)

\*2 : A high-speed mode I<sup>2</sup>C bus device can be used for a typical mode I<sup>2</sup>C bus system as long as the device satisfies a requirement of “t<sub>SUDAT</sub> ≥ 250 ns”.

When a device does not extend the “L” period of the SCL signal, the next data must be outputted to the SDA line within 1250 ns (maximum SDA/SCL rise time + t<sub>SUDAT</sub>) in which the SCL line is released.

\*3 : For use at over 100 kHz, set the resource clock to at least 6 MHz.

\*4 : R and C represent the pull-up resistor and load capacitor of the SCL and SDA output lines, respectively.

# MB91345 Series

- At slave mode operating

( $V_{CC} = AV_{CC} = 3.0\text{ V to }3.6\text{ V}$ ,  $V_{SS} = AV_{SS} = 0\text{ V}$ ,  $T_a = -40\text{ }^\circ\text{C to }+85\text{ }^\circ\text{C}$ )

Parameter	Symbol	Pin name	Conditions	Typical mode		High-speed mode* <sup>3</sup>		Unit	Remarks
				Min	Max	Min	Max		
SCL clock frequency	$f_{SCL}$	SDA, SCL	$R = 1\text{ k}\Omega$ $C = 50\text{ pF}^4$	0	100	0	400	kHz	
“L” period of SCL clock	$t_{LOW}$			4.7	—	1.3	—	$\mu\text{s}$	
“H” period of SCL clock	$t_{HIGH}$			4.0	—	0.6	—	$\mu\text{s}$	
SCL $\downarrow \rightarrow$ SDA output delay time	$t_{DL DAT}$			—	$5 \times M^1$	—	$5 \times M^1$	ns	
Bus free time between [STOP condition and START condition]	$t_{BUS}$			4.7	—	1.3	—	$\mu\text{s}$	
SDA data input hold time (vs. SCL $\downarrow$ )	$t_{HDDAT}$			$2 \times M^1$	—	$2 \times M^1$	—	$\mu\text{s}$	
SDA data input setup time (vs. SCL $\uparrow$ )	$t_{SUDAT}$			250	—	$100^2$	—	ns	
Setup time of [repeat START condition] SCL $\uparrow \rightarrow$ SDA $\downarrow$	$t_{SUSTA}$			4.7	—	0.6	—	$\mu\text{s}$	
Hold time of [repeat START condition] SDA $\downarrow \rightarrow$ SCL $\downarrow$	$t_{HDSTA}$			4.0	—	0.6	—	$\mu\text{s}$	After that, the first clock pulse is generated.
Setup time of [STOP condition] SCL $\uparrow \rightarrow$ SDA $\uparrow$	$t_{SUSTO}$			4.0	—	0.6	—	$\mu\text{s}$	

\*1 : M = Resource clock cycle (ns)

\*2 : A high-speed mode I<sup>2</sup>C bus device can be used for a typical mode I<sup>2</sup>C bus system as long as the device satisfies a requirement of “ $t_{SUDAT} \geq 250\text{ ns}$ ”.

When the device does not extend the “L” period of the SCL signal, the next data must be outputted to the SDA line within 1250 ns (maximum SDA/SCL rise time +  $t_{SUDAT}$ ) in which the SCL line is released.

\*3 : For use at over 100 kHz, set the resource clock to at least 6 MHz.

\*4 : R and C represent the pull-up resistor and load capacitor of the SCL and SDA output lines, respectively.

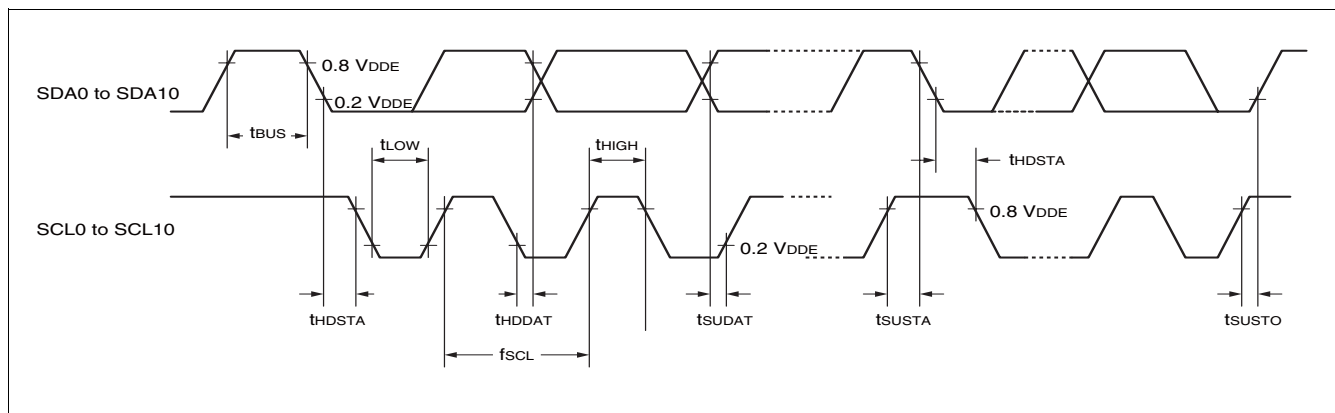

## (8) Regulator Voltage Wait Time

( $V_{CC} = AV_{CC} = 3.0\text{ V to }3.6\text{ V}$ ,  $V_{SS} = AV_{SS} = 0\text{ V}$ ,  $T_a = -40\text{ }^\circ\text{C to }+85\text{ }^\circ\text{C}$ )

Parameter	Symbol	Value		Unit	Remarks
		Min	Max		
Regulator voltage wait time	$t_{REG}$	250	—	$\mu\text{s}$	Wait time until the regulator voltage is stable

# MB91345 Series

## 5. Electrical Characteristics for the A/D Converter

( $V_{CC} = AV_{CC} = 3.0\text{ V to }3.6\text{ V}$ ,  $V_{SS} = AV_{SS} = 0\text{ V}$ ,  $AVRH = 3.0\text{ V to }3.6\text{ V}$ ,  $T_a = -40\text{ }^\circ\text{C to }+85\text{ }^\circ\text{C}$ )

Parameter	Value			Unit	Remarks
	Min	Typ	Max		
Resolution	—	—	10	bit	
Total error*1	-3.0	—	+3.0	LSB	AV <sub>CC</sub> = 3.3 V, AVRH = 3.3 V
Nonlinear error*1	-2.5	—	+2.5	LSB	
Differential linear error*1	-1.9	—	+1.9	LSB	
Zero transition voltage*1	-1.5	+0.5	+2.5	LSB	
Full transition voltage*1	AVRH-3.5	AVRH-1.5	AVRH+0.5	LSB	
Minimum comparison time*2	0.6	—	—	μs	Not including sampling time
Minimum sampling time*2	0.3*3	—	—	μs	
Conversion time	0.9*3	1.1	—	μs	
Power supply current (analog + digital)	—	7.2	—	mA	At operating A/D converter 2 units
	—	—	5	μA	At power down operation*4
Reference power supply current (between AVRH and AVRL)	—	940	—	μA	At operating A/D converter 2 units AVRH = 3.0 V, AVRL = 0.0 V
	—	—	10	μA	At power down operation*4
Analog input capacitance	—	—	20	pF	
Interchannel disparity	—	—	4	LSB	

\*1 : Measured in the CPU sleep state.

\*2 : Depends on the clock cycle supplied to the peripheral resource.

\*3 : No external load

\*4 : Current when the A/D converter is not operating and the CPU is in stop mode

• About the external impedance of the analog input and its sampling time

- A/D converter with sample and hold circuit. If the external impedance is too high to keep sufficient sampling time, the analog voltage charged to the internal sampling and hold capacitor is insufficient, adversely affecting A/D conversion precision. Therefore, to satisfy the A/D conversion precision standard, consider the relationship between the external impedance and minimum sampling time and either adjust the resistor value and operating frequency or decrease the external impedance so that the sampling time is longer than the minimum value. If the sampling time cannot be sufficient, connect a capacitor of about 0.1  $\mu\text{F}$  to the analog input pin.

• Analog input circuit model

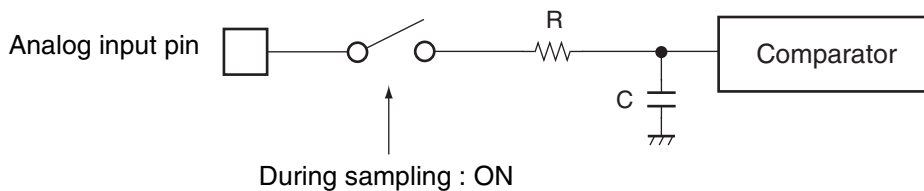

Note : The values are reference values.

	R	C
MB91F345B/F346B	1.5 k $\Omega$ (Max)	20.0 pF (Max)

• The relationship between the external impedance and minimum sampling time

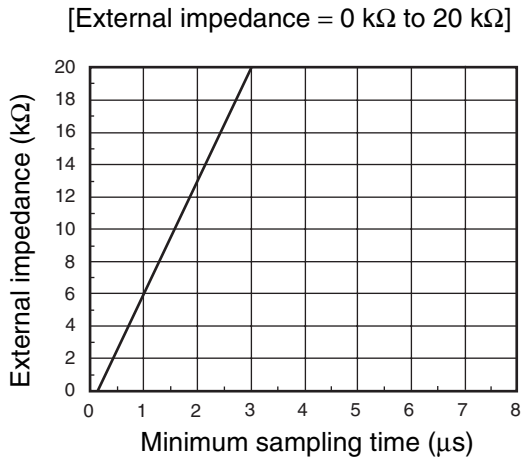
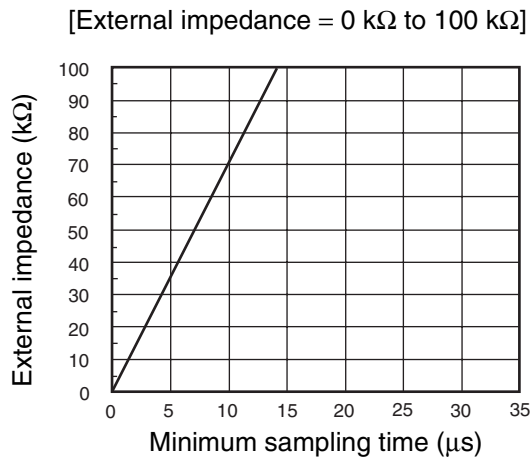

# MB91345 Series

## • A/D Converter Block Electrical Characteristics

- Resolution  
Analog variations recognized by an A/D converter.
- Linearity error  
Deviation of actual conversion characteristics from an ideal line, which is across zero-transition point (“00 0000 0000” ↔ “00 0000 0001”) and full-scale transition point (“11 1111 1110” ↔ “11 1111 1111”).
- Differential linearity error  
Deviation from ideal value of input voltage, which is required for changing output code by 1 LSB.
- Total error  
Difference between actual value and ideal value. The error includes zero-transition error, full-scale transition error, and linearity error.

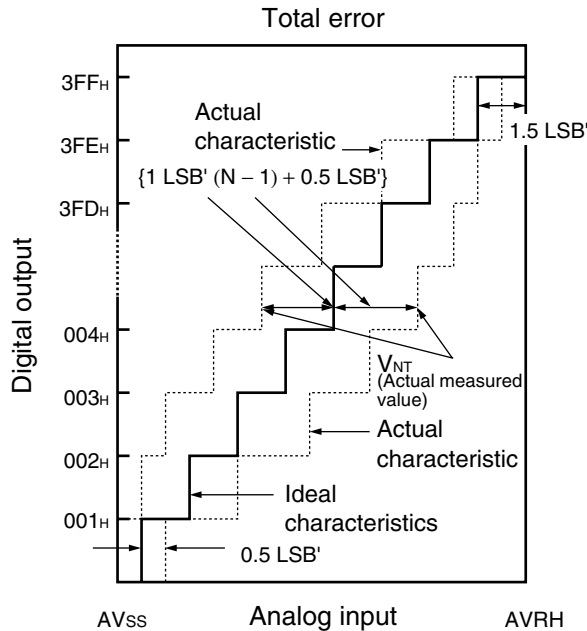

$$1 \text{ LSB}' (\text{ideal value}) = \frac{\text{AVRH} - \text{AVSS}}{1024} [\text{V}]$$

$$\text{Total error of digital output } N = \frac{V_{\text{NT}} - \{1 \text{ LSB}' \times (N - 1) + 0.5 \text{ LSB}'\}}{1 \text{ LSB}'}$$

$V_{\text{NT}}$  : Transition voltage for digital output to change from  $(N + 1)_H$  to  $N_H$ .

$$V_{\text{OT}}' (\text{ideal value}) = \text{AVSS} + 0.5 \text{ LSB}' [\text{V}]$$

$$V_{\text{FST}}' (\text{ideal value}) = \text{AVRH} - 1.5 \text{ LSB}' [\text{V}]$$

(Continued)

(Continued)

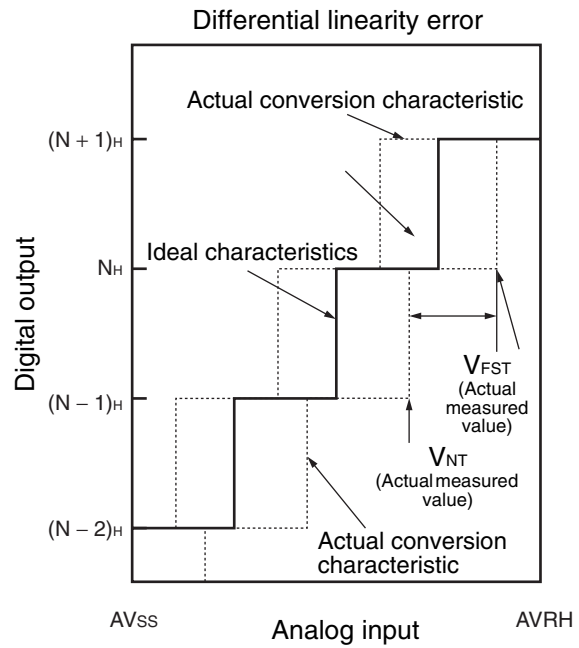
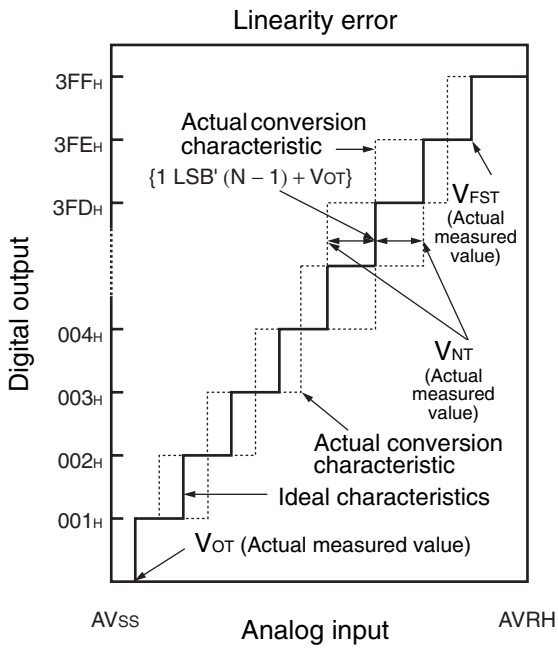

$$\text{Linearity error of digital output } N = \frac{V_{NT} - \{1 \text{ LSB}' \times (N - 1) + V_{OT}\}}{1 \text{ LSB}'} \text{ [LSB]}$$

$$\text{Differential linearity error of digital output } N = \frac{V_{(N+1)T} - V_{NT}}{1 \text{ LSB}'} - 1 \text{ [LSB]}$$

$$1 \text{ LSB} = \frac{V_{FST} - V_{OT}}{1022} \text{ [V]}$$

$V_{OT}$  : Transition voltage for digital output to change from (000)<sub>H</sub> to (001)<sub>H</sub>.

$V_{FST}$  : Transition voltage for digital output to change from (3FE)<sub>H</sub> to (3FF)<sub>H</sub>.

## • About errors

- As  $|AVRH - AVss|$  becomes smaller, values of relative errors grow larger.

# MB91345 Series

## 6. Flash Memory Write/Erase Characteristics

( $V_{CC} = AV_{CC} = 3.0\text{ V to }3.6\text{ V}$ ,  $V_{SS} = AV_{SS} = 0\text{ V}$ ,  $T_a = -40\text{ °C to }+85\text{ °C}$ )

Parameter	Conditions	Value			Unit	Remarks
		Min	Typ	Max		
Sector erase time	—	—	1	15	s	Excludes 00 <sub>H</sub> programming prior erasure
Byte write time	—	—	6	100	μs	Not including system-level overhead time
Chip write time	—	—	3.4	56	s	Not including system-level overhead time
Erase/write cycle	—	10000	—	—	cycle	
Flash memory data retain period	Average $T_a = +55\text{ °C}$	10	—	—	year	*

\* : This value comes from the technology qualification (using Arrhenius equation to translate high temperature measurements into normalized value at + 55 °C) .

## ■ ORDERING INFORMATION

Part number	Package
MB91F345BPFT-GE1 MB91F346BPFT-GE1	100-pin plastic TQFP (FPT-100P-M18)

# MB91345 Series

## PACKAGE DIMENSIONS

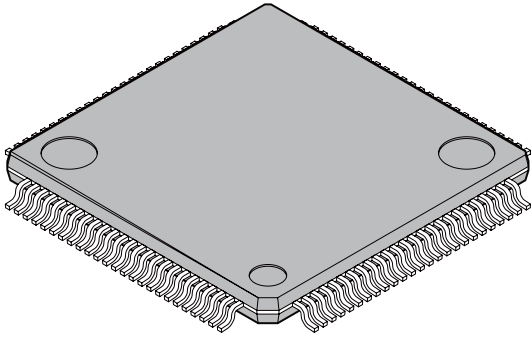
 <p>100-pin plastic TQFP</p> <p>(FPT-100P-M18)</p>	Lead pitch	0.40 mm
	Package width × package length	12.0 × 12.0 mm
	Lead shape	Gullwing
	Sealing method	Plastic mold
	Mounting height	1.20 mm MAX
	Weight	0.40g
	Code(Reference)	P-TFQFP100-12 × 12-0.40

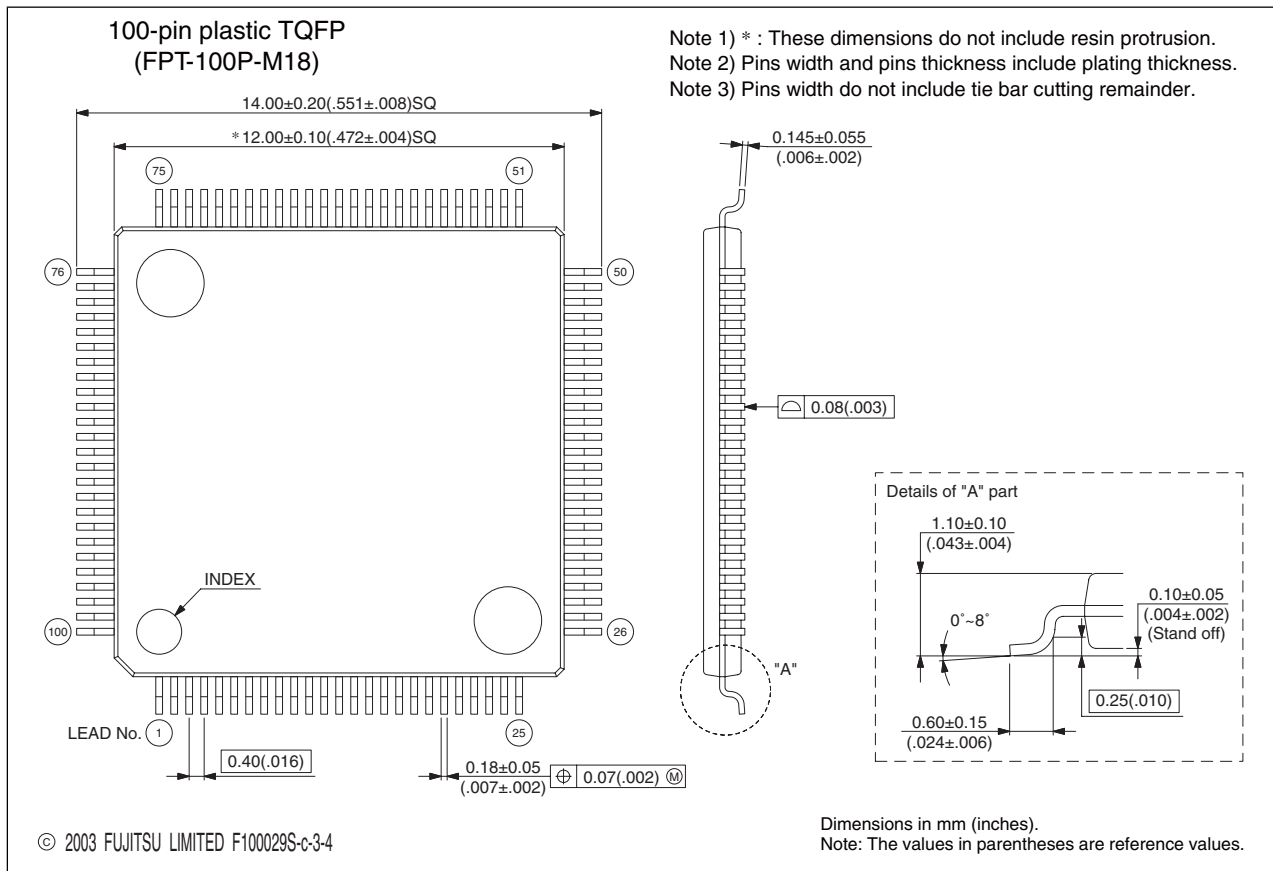

Please confirm the latest Package dimension by following URL.  
<http://edevice.fujitsu.com/package/en-search/>

## ■ MAIN CHANGES IN THIS EDITION

Page	Section	Change Results
4	■ PIN ASSIGNMENT	Added the Example Characteristics pins of I <sup>2</sup> C (SDA0 to SDA10,SCL0 to SCL10) .
5, 6, 8 to 11,	■ PIN DESCRIPTION	
23	■ BLOCK DIAGRAM	
42	■ I/O MAP Address 000420 <sub>H</sub> to 00042C <sub>H</sub>	“Register” is changed to “Port Function Registers”.
	Address 000430 <sub>H</sub>	“Register” is changed to “Reserved”.
	Address 000440 <sub>H</sub> to 00046C <sub>H</sub>	“Interrupt control unit” is changed to “Interrupt Control Register”.
43	Address 000500 <sub>H</sub> to 000510 <sub>H</sub>	“Port Pull-up Control Registers” is changed to “Pull-up Control Registers”.
44	Address 0007FC <sub>H</sub>	“—” is changed to “Mode Register”.
46	Address 007020 <sub>H</sub>	“Reserved” is changed to “Wild Register Enable Register”.
60	■ ELECTRICAL CHARACTERISTICS 4. AC Characteristics (7) I <sup>2</sup> C timing • At slave mode operating	Added the fugire of timing.

The vertical lines marked in the left side of the page show the changes.

**MEMO**



**MEMO**



# FUJITSU MICROELECTRONICS LIMITED

Shinjuku Dai-Ichi Seimei Bldg. 7-1, Nishishinjuku 2-chome, Shinjuku-ku,  
Tokyo 163-0722, Japan Tel: +81-3-5322-3347 Fax: +81-3-5322-3387  
<http://jp.fujitsu.com/fml/en/>

*For further information please contact:*

## **North and South America**

FUJITSU MICROELECTRONICS AMERICA, INC.  
1250 E. Arques Avenue, M/S 333  
Sunnyvale, CA 94085-5401, U.S.A.  
Tel: +1-408-737-5600 Fax: +1-408-737-5999  
<http://www.fma.fujitsu.com/>

## **Europe**

FUJITSU MICROELECTRONICS EUROPE GmbH  
Pittlerstrasse 47, 63225 Langen,  
Germany  
Tel: +49-6103-690-0 Fax: +49-6103-690-122  
<http://emea.fujitsu.com/microelectronics/>

## **Korea**

FUJITSU MICROELECTRONICS KOREA LTD.  
206 KOSMO TOWER, 1002 Daechi-Dong,  
Kangnam-Gu, Seoul 135-280  
Korea  
Tel: +82-2-3484-7100 Fax: +82-2-3484-7111  
<http://www.fmk.fujitsu.com/>

## **Asia Pacific**

FUJITSU MICROELECTRONICS ASIA PTE LTD.  
151 Lorong Chuan, #05-08 New Tech Park,  
Singapore 556741  
Tel: +65-6281-0770 Fax: +65-6281-0220  
<http://www.fujitsu.com/sg/services/micro/semiconductor/>

FUJITSU MICROELECTRONICS SHANGHAI CO., LTD.  
Rm.3102, Bund Center, No.222 Yan An Road(E),  
Shanghai 200002, China  
Tel: +86-21-6335-1560 Fax: +86-21-6335-1605  
<http://cn.fujitsu.com/fmc/>

FUJITSU MICROELECTRONICS PACIFIC ASIA LTD.  
10/F., World Commerce Centre, 11 Canton Road  
Tsimshatsui, Kowloon  
Hong Kong  
Tel: +852-2377-0226 Fax: +852-2376-3269  
<http://cn.fujitsu.com/fmc/tw>

All Rights Reserved.

The contents of this document are subject to change without notice.

Customers are advised to consult with sales representatives before ordering.

The information, such as descriptions of function and application circuit examples, in this document are presented solely for the purpose of reference to show examples of operations and uses of FUJITSU MICROELECTRONICS device; FUJITSU MICROELECTRONICS does not warrant proper operation of the device with respect to use based on such information. When you develop equipment incorporating the device based on such information, you must assume any responsibility arising out of such use of the information.

FUJITSU MICROELECTRONICS assumes no liability for any damages whatsoever arising out of the use of the information.

Any information in this document, including descriptions of function and schematic diagrams, shall not be construed as license of the use or exercise of any intellectual property right, such as patent right or copyright, or any other right of FUJITSU MICROELECTRONICS or any third party or does FUJITSU MICROELECTRONICS warrant non-infringement of any third-party's intellectual property right or other right by using such information. FUJITSU MICROELECTRONICS assumes no liability for any infringement of the intellectual property rights or other rights of third parties which would result from the use of information contained herein.

The products described in this document are designed, developed and manufactured as contemplated for general use, including without limitation, ordinary industrial use, general office use, personal use, and household use, but are not designed, developed and manufactured as contemplated (1) for use accompanying fatal risks or dangers that, unless extremely high safety is secured, could have a serious effect to the public, and could lead directly to death, personal injury, severe physical damage or other loss (i.e., nuclear reaction control in nuclear facility, aircraft flight control, air traffic control, mass transport control, medical life support system, missile launch control in weapon system), or (2) for use requiring extremely high reliability (i.e., submersible repeater and artificial satellite).

Please note that FUJITSU MICROELECTRONICS will not be liable against you and/or any third party for any claims or damages arising in connection with above-mentioned uses of the products.

Any semiconductor devices have an inherent chance of failure. You must protect against injury, damage or loss from such failures by incorporating safety design measures into your facility and equipment such as redundancy, fire protection, and prevention of over-current levels and other abnormal operating conditions.

Exportation/release of any products described in this document may require necessary procedures in accordance with the regulations of the Foreign Exchange and Foreign Trade Control Law of Japan and/or US export control laws.

The company names and brand names herein are the trademarks or registered trademarks of their respective owners.