

# 32-bit Microcontroller

CMOS

## FR60 MB91350A Series

### MB91F355A/F353A/F356B/F357B/355A/354A/ MB91353A/352A/351A/V350A

#### ■ DESCRIPTION

The FR family\* is a series of standard single-chip microcontrollers that feature a variety of built-in I/O resources and bus control functions, and that employ a high-performance 32-bit RISC CPU for embedded control applications that demand powerful and fast CPU processing capabilities.

This product is one of the FR60 family based on the FR30/40 family CPU with enhanced bus access. The FR60 family is a line of single-chip oriented microcontrollers that incorporate a wealth of peripheral resources.

The FR60 family is optimized for embedded control applications that require high CPU processing power, such as DVD players, navigation equipment, high performance fax machines, and printer controllers.

\* : FR, the abbreviation of FUJITSU RISC controller, is a line of products of Fujitsu Microelectronics Limited.

#### ■ FEATURES

##### 1. FR CPU

- 32-bit RISC, load/store architecture with a five-stage pipeline
- Maximum operating frequency : 50 MHz (using the PLL at an oscillation frequency of 12.5 MHz)
- 16-bit fixed length instructions (basic instructions), 1 instruction per cycle
- Instruction set optimized for embedded applications : Memory-to-memory transfer, bit manipulation, barrel shift etc.
- Instructions adapted for high-level languages : Function entry/exit instructions, multiple-register load/store instructions
- Register interlock functions : Facilitate coding in assemblers

(Continued)

For the information for microcontroller supports, see the following web site.

<http://edevic.fujitsu.com/micom/en-support/>

# MB91350A Series

- On-chip multiplier supported at the instruction level.  
Signed 32-bit multiplication : 5 cycles  
Signed 16-bit multiplication : 3 cycles
- Interrupt (PC, PS save) : 6 cycles, 16 priority levels
- Harvard architecture allowing program access and data access to be executed simultaneously
- Instructions compatible with the FR family

## 2. Bus interface

- Maximum operating frequency : 25 MHz
- 24-bit address full output (16 Mbyte address space) capability  
(21-bit address full output (2 Mbyte address space) capability : MB91F353A/353A/352A/351A)
- 8,16-bit data output
- Built-in prefetch buffer
- Unused data and address pins can be used as general I/O ports.
- Able to output chip-select for 4 completely independent areas that can be configured in units of 64 Kbytes
- Support for various memory interfaces :  
SRAM, ROM/Flash  
page mode Flash ROM, page mode ROM interface
- Basic bus cycle : 2 cycles
- Programmable automatic wait cycle generator capable of inserting wait cycles for each area
- RDY input for external wait cycles
- DMA support of fly-by transfer capable of wait control for independent I/O  
(The MB91F353A/353A/352A/351A does not support fly-by transfer.)

## 3. Built-in memory

D-bus memory	MB91V350A	MB91F353A MB91F355A MB91F357B	MB91F356B	MB91353A MB91355A	MB91352A MB91354A	MB91351A
ROM	No	512 Kbytes	256 Kbytes	512 Kbytes	384 Kbytes	384 Kbytes
RAM (Stack)	16 Kbytes	16 Kbytes	16 Kbytes	16 Kbytes	8 Kbytes	16 Kbytes
RAM (Execute instruction)	16 Kbytes	8 Kbytes	8 Kbytes	8 Kbytes	8 Kbytes	8 Kbytes

## 4. DMAC (DMA Controller)

- Capable of simultaneous operation of up to 5 channels (external → external : 3 channels)
- 3 transfer sources (external pin, internal peripheral or software) :  
Activation sources are software-selectable (transfer can be activated by UART0/1/2).
- Addressing using 32-bit full addressing mode (increment, decrement, fixed)
- Transfer modes (demand transfer, burst transfer, step transfer, block transfer)
- Fly-by transfer support (between external I/O and memory)
- Selectable transfer data size : 8, 16, or 32-bit
- Multi-byte transfer capability (selected by software)
- DMAC descriptor in IO areas (200<sub>H</sub> to 240<sub>H</sub>, 1000<sub>H</sub> to 1024<sub>H</sub>)  
(The MB91F353A/353A/352A/351A does not have an external interface.)  
External pin transfer is not supported. Demand transfer and fly-by transfer cannot be used.

## 5. Bit search module (for REALOS)

- Search a single word starting from the MSB for the position of the first bit changed from 1 to 0.

(Continued)

## 6. Various timers

- 4 channels of 16-bit reload timer (including 1 channel for REALOS) :  
Internal clock frequency divider selectable from 2/8/32 (division by 64/128 selectable only for ch.3)
- 16-bit free-run timer : 1 channel  
Output compare : 8 channels (MB91F353A/353A/352A/351A : 2 channels)  
Input capture : 4 channels
- 16-bit PPG timer : 6 channels (MB91F353A/353A/352A/351A : 3 channels)

## 7. UART

- UART full duplex double buffer : 5 channels (MB91F353A/353A/352A/351A : 4 channels)
- Selectable parity on/off
- Asynchronous (start-stop synchronized) or CLK-synchronous communications selectable
- Built-in dedicated baud rate timer
- External clock can be used as transfer clock
- Assorted error detection functions (for parity, frame, and overrun errors)
- Support for 115 kbps

## 8. SIO

- 8-bit data serial transfer : 3 channels (MB91F353A/353A/352A/351A : 2 channels)
- Shift clock selectable from among three internal and one external
- Shift direction selectable (transfer from LSB or MSB)

## 9. Interrupt controller

- Total number of external interrupts : 17 (MB91F353A/353A/352A/351A : 9)  
(One non-maskable interrupt pin and 16/8 ordinary interrupt pins that can be used for wakeup in stop mode.)
- Interrupts from internal peripherals
- Programmable priorities (16 levels) for all interrupts except the non-maskable interrupt

## 10. D/A converter

- 8-bit resolution : 3 channels (MB91F353A/353A/352A/351A : 2 channels)

## 11. A/D converter

- 10-bit resolution : 12 channels (MB91F353A/353A/352A/351A : 8 channels)
- Serial/parallel conversion type Conversion time : 1.48  $\mu$ s
- Conversion mode (one shot conversion mode, continuous conversion mode)
- Activation source (software, external trigger, peripheral interrupt)

## 12. Other interval timer/counter

- 8/16-bit up/down counter  
The MB91F353A/353A/352A/351A supports only an 8-bit up/down counter.
- 16-bit timer (U-TIMER) : 5 channels (MB91F353A/353A/352A/351A : 4 channels)
- Watch dog timer

## 13. I<sup>2</sup>C bus interface (supports 400 kbps)

- 1 channel master/slave transmission and reception
- Arbitration and clock synchronization functions

## 14. I/O ports

- 3 V I/O ports  
(5 V input is supported for those ports that are also used for external interrupts (16 ports, MB91F353A/353A/352A/351A : 8 ports).
- Up to 126 ports (MB91F353A/353A/352A/351A : Up to 84 ports)

(Continued)

(Continued)

## 15. Other features

- Internal oscillator circuit as clock source, and PLL multiplication can be selected
- $\overline{\text{INIT}}$  pin provided as a reset pin (the oscillation stabilization wait time when the  $\overline{\text{INIT}}$  pin is reset is clock cycle  $\times 2$ .)
- Watch dog timer reset and software reset are also provided.
- Support for stop and sleep modes for low power consumption, capable of saving power by operating the CPU at 32 kHz.
- Gear function
- Built-in time base timer
- Package : MB91F355A/F356B/355A/354A/F357B : LQFP-176 (lead pitch 0.50 mm)  
MB91F353A/353A/352A/351A : LQFP-120 (lead pitch 0.50 mm)
- CMOS technology(0.35  $\mu\text{m}$ )
- Power supply voltage : 3.3 V  $\pm$  0.3 V  
2.7 V to 3.6 V (MB91F356B/F357B only)



# MB91350A Series

• MB91F355A/F356B/F357B/355A/354A

(TOP VIEW)

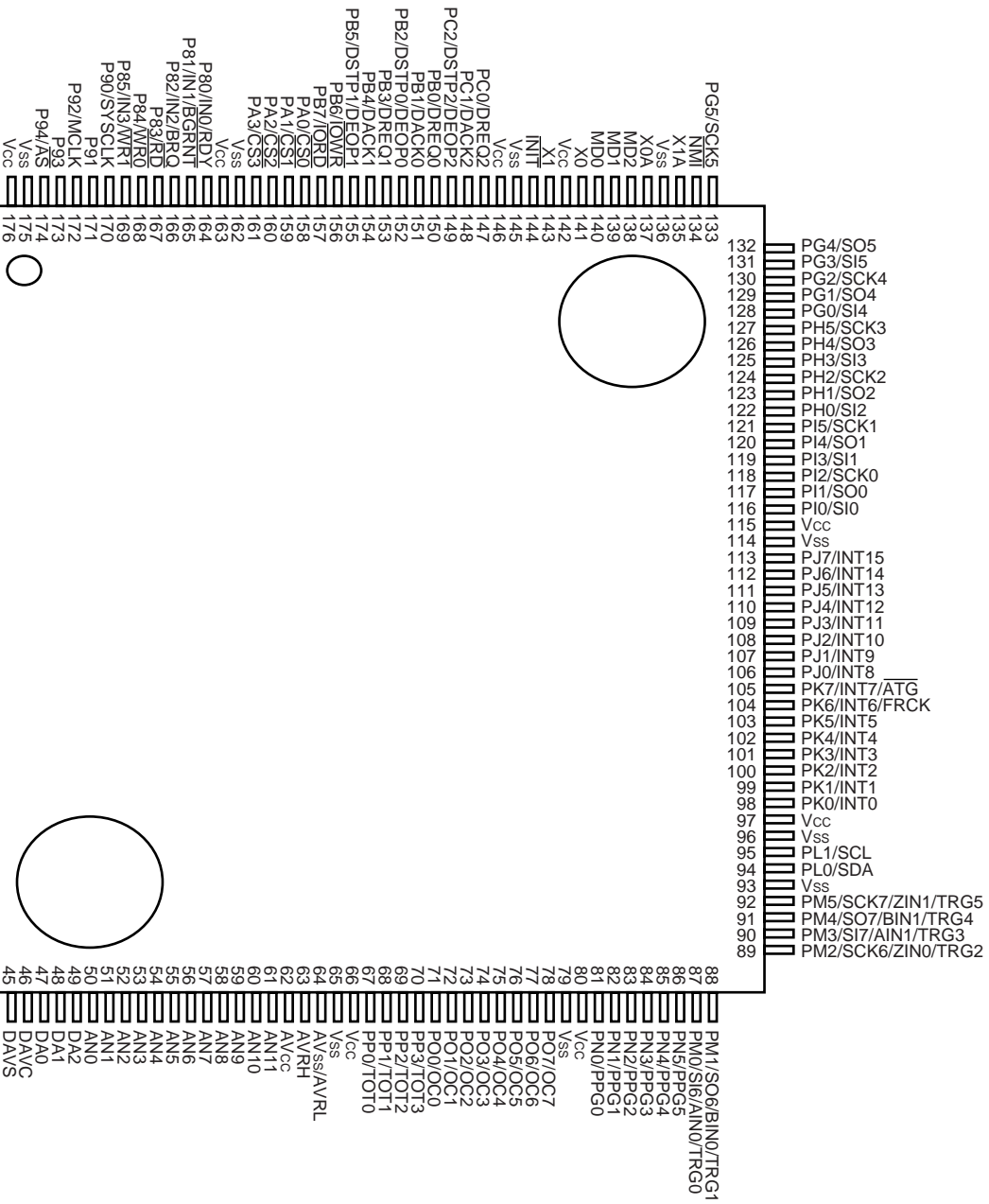

(FPT-176P-M02)

## ■ PIN DESCRIPTION

Pin no.		Pin name	I/O circuit type*3	Function
LQFP*1	LQFP*2			
1 to 8	1 to 8	D16 to D23	C	Bit 16 to bit 23 of the external data bus. Valid only in external bus mode.
		P20 to P27		Can be used as ports while in external bus 8-bit mode.
9 to 16	9 to 16	D24 to D31	C	Bit 24 to bit 31 of the external data bus. Valid only in external bus mode.
		P30 to P37		Can be used as ports while in single-chip mode.
19 to 26	17, 20 to 26	A00 to A07	C	Bit 0 to bit 7 of the external address bus. Valid only in external bus mode.
		P40 to P47		Can be used as ports while in single-chip mode.
27 to 34	27 to 34	A08 to A15	C	Bit 8 to bit 15 of the external address bus. Valid only in external bus mode.
		P50 to P57		Can be used as ports while in single-chip mode.
37 to 41	35 to 39	A16 to A20	C	Bit 16 to bit 20 of the external address bus. Valid only in external bus mode.
		P60 to P64		Can be used as ports while in single-chip mode or when the external address bus is not used.
42 to 44	—	A21 to A23	C	Bit 21 to bit 23 of the external address bus. Valid only in external bus mode.
		P65 to P67		Can be used as ports while in single-chip mode or when the external address bus is not used.
47, 48	106, 105	DA0, DA1	—	D/A converter output pins
49	—	DA2	—	D/A converter output pin
50 to 57	113 to 120	AN0 to AN7	G	Analog input pins
58 to 61	—	AN8 to AN11	G	Analog input pins
67 to 70	—	TOT0 to TOT3	D	Reload timer output ports. This pin is valid when timer output is enabled.
		PP0 to PP3		General-purpose I/O ports. This pin is valid when the timer output function is disabled.
71	97	OC0	D	Output compare output pin
		PO0		General-purpose I/O port. This pin can be used as a port when the output compare output is not used.

(Continued)

# MB91350A Series

Pin no.		Pin name	I/O circuit type*3	Function
LQFP*1	LQFP*2			
72	—	OC1	D	Output compare output pin
		PO1		General-purpose I/O port. This pin can be used as a port when the output compare output is not used.
73	98	OC2	D	Output compare output pin
		PO2		General-purpose I/O port. This pin can be used as a port when the output compare output is not used.
74 to 78	—	OC3 to OC7	D	Output compare output pins
		PO3 to PO7		General-purpose I/O ports. These pins can be used as ports when the output compare outputs are not used.
81	70	PPG0	D	PPG timer output pin
		PN0		General-purpose I/O port. This pin can be used as a port when the PPG timer output is not used.
82	—	PPG1	D	PPG timer output pin
		PN1		General-purpose I/O port. This pin can be used as a port when the PPG timer output is not used.
83	71	PPG2	D	PPG timer output pin
		PN2		General-purpose I/O port. This pin can be used as a port when the PPG timer output is not used.
84	—	PPG3	D	PPG timer output pin
		PN3		General-purpose I/O port. This pin can be used as a port when the PPG timer output is not used.
85	72	PPG4	D	PPG timer output pin
		PN4		General-purpose I/O port. This pin can be used as a port when the PPG timer output is not used.
86	—	PPG5	D	PPG timer output pin
		PN5		General-purpose I/O port. This pin can be used as a port when the PPG timer output is not used.

(Continued)

# MB91350A Series

Pin no.		Pin name	I/O circuit type*3	Function
LQFP*1	LQFP*2			
87	73	SI6	D	Data input for serial I/O6. Since this input is always used when serial I/O6 input is operating, output using the port must be stopped beforehand unless this operation is the intended operation.
		AIN0		Input for the up/down counter. Since this input is always used when input is enabled, output using the port must be stopped beforehand unless this operation is the intended operation.
		TRG0		External trigger input for PPG timer 0. Since this input is always used when input is enabled, output using the port must be stopped beforehand unless this operation is the intended operation.
		PM0		General-purpose I/O port. This pin can be used as a port when serial I/O, up/down counter, and PPG timer output are not used.
88	74	SO6	D	Data output from serial I/O6. This function is valid when data output from serial I/O6 is enabled.
		BIN0		Input for the up/down counter. Since this input is always used when input is enabled, output using the port must be stopped beforehand unless this operation is the intended operation.
		TRG1		External trigger input for PPG timer 1. Since this input is always used when input is enabled, output using the port must be stopped beforehand unless this operation is the intended operation.
		PM1		General-purpose I/O port. This pin can be used as a port when serial I/O, up/down counter, and PPG timer output are not used.
89	75	SCK6	D	Clock I/O for serial I/O 6. This function is valid when clock output from serial I/O6 is enabled or when an external shift clock input is used.
		ZIN0		Input for the up/down counter. Since this input is always used when input is enabled, output using the port must be stopped beforehand unless this operation is the intended operation.
		TRG2		External trigger input for PPG timer 2. Since this input is always used when input is enabled, output using the port must be stopped beforehand unless this operation is the intended operation.
		PM2		General-purpose I/O port. This pin can be used as a port when serial I/O, up/down counter, and PPG timer output are not used.

(Continued)

# MB91350A Series

Pin no.		Pin name	I/O circuit type*3	Function
LQFP*1	LQFP*2			
90	78	S17	D	Data input for serial I/O7. Since this input is always used when serial I/O7 input is operating, output using the port must be stopped beforehand unless this operation is the intended operation.
		AIN1*4		Input for the up/down counter. Since this input is always used when input is enabled, output using the port must be stopped beforehand unless this operation is the intended operation.
		TRG3		External trigger input for PPG timer 3. Since this input is always used when input is enabled, output using the port must be stopped beforehand unless this operation is the intended operation.
		PM3		General-purpose I/O port. This pin can be used as a port when serial I/O, up/down counter, and PPG timer output are not used.
91	79	S07	D	Data output from serial I/O7. This function is valid when data output from serial I/O7 is enabled.
		BIN1*4		Input for the up/down counter. Since this input is always used when input is enabled, output using the port must be stopped beforehand unless this operation is the intended operation.
		TRG4		External trigger input for PPG timer 4. Since this input is always used when input is enabled, output using the port must be stopped beforehand unless this operation is the intended operation.
		PM4		General-purpose I/O port. This pin can be used as a port when serial I/O, up/down counter, and PPG timer output are not used.
92	80	SCK7	D	Clock I/O for serial I/O7. This function is valid when clock output from serial I/O7 is enabled or when an external shift clock input is used.
		ZIN1*4		Input for the up/down counter. Since this input is always used when input is enabled, output using the port must be stopped beforehand unless this operation is the intended operation.
		TRG5*4		External trigger input for PPG timer 5. Since this input is always used when input is enabled, output using the port must be stopped beforehand unless this operation is the intended operation.
		PM5		General-purpose I/O port. This pin can be used as a port when serial I/O, up/down counter, and PPG timer output are not used.

(Continued)

# MB91350A Series

Pin no.		Pin name	I/O circuit type*3	Function
LQFP*1	LQFP*2			
94	42	SDA	F	DATA I/O pin for the I <sup>2</sup> C bus. This pin is valid when standard mode I <sup>2</sup> C operation is enabled. Output using the port must be stopped beforehand unless this operation is intended (open drain output).
		PL0		General-purpose I/O port. This pin can be used as a port when I <sup>2</sup> C operation is disabled (open drain output).
95	41	SCL	F	Clock I/O pin for the I <sup>2</sup> C bus. This pin is valid when standard mode I <sup>2</sup> C operation is enabled. Output using the port must be stopped beforehand unless this operation is intended (open drain output).
		PL1		General-purpose I/O port. This pin can be used as a port when I <sup>2</sup> C operation is disabled (open drain output).
98 to 103	81 to 86	INT0 to INT5	E	External interrupt inputs. Since these inputs are always used when the corresponding external interrupts are enabled, output using the ports must be stopped beforehand unless this operation is the intended operation.
		PK0 to PK5		General-purpose I/O ports
104	87	INT6	E	External interrupt input. Since this input is always used when the corresponding external interrupt is enabled, output using the port must be stopped beforehand unless this operation is the intended operation.
		FRCK		External clock input pin for the free-run timer. Since this input is always used when it is selected as the external clock input for the free-run timer, output using the port must be stopped beforehand unless this operation is the intended operation.
		PK6		General-purpose I/O port
105	88	INT7	E	External interrupt input. Since this input is always used when the corresponding external interrupt is enabled, output using the port must be stopped beforehand unless this operation is the intended operation.
		$\overline{\text{ATG}}$		External trigger for the A/D converter. Since this input is always used when it is selected as the A/D activation source, output using the port must be stopped beforehand unless this operation is the intended operation.
		PK7		General-purpose I/O port

(Continued)

# MB91350A Series

Pin no.		Pin name	I/O circuit type*3	Function
LQFP*1	LQFP*2			
106 to 113	—	INT8 to INT15	E	External interrupt inputs. Since these inputs are always used when the corresponding external interrupts are enabled, output using the ports must be stopped beforehand unless this operation is the intended operation.
		PJ0 to PJ7		General-purpose I/O ports
116	89	SI0	D	Data input for UART0. Since this input is always used when UART0 input is operating, output using the port must be stopped beforehand unless this operation is the intended operation.
		PI0		General-purpose I/O port
117	90	SO0	D	Data output from UART0. This function is valid when UART0 data output is enabled.
		PI1		General-purpose I/O port. This function is valid when UART0 data output is disabled.
118	91	SCK0	D	Clock I/O for UART0. This function is valid when UART0 clock output is enabled or when an external clock input is used.
		PI2		General-purpose I/O port. This function is valid when UART0 clock output is disabled or when an external clock input is not used.
119	92	SI1	D	Data input for UART1. Since this input is always used when UART1 input is operating, output using the port must be stopped beforehand unless this operation is the intended operation.
		PI3		General-purpose I/O port
120	93	SO1	D	Data output from UART1. This function is valid when UART1 data output is enabled.
		PI4		General-purpose I/O port. This function is valid when UART1 data output is disabled.
121	94	SCK1	D	Clock I/O for UART1. This function is valid when UART1 clock output is enabled or when an external clock input is used.
		PI5		General-purpose I/O port. This function is valid when UART1 clock output is disabled or when an external clock input is not used.
122	99	SI2	D	Data input for UART2. Since this input is always used when UART2 input is operating, output using the port must be stopped beforehand unless this operation is the intended operation.
		PH0		General-purpose I/O port

(Continued)

# MB91350A Series

Pin no.		Pin name	I/O circuit type*3	Function
LQFP*1	LQFP*2			
123	100	SO2	D	Data output from UART2. This function is valid when UART2 data output is enabled.
		PH1		General-purpose I/O port. This function is valid when UART2 data output is disabled or when an external shift clock input is used.
124	101	SCK2	D	Clock I/O for UART2. This function is valid when UART2 clock output is enabled or when an external clock input is used.
		PH2		General-purpose I/O port. This function is valid when UART2 clock output is disabled or when an external clock input is not used.
125	102	SI3	D	Data input for UART3. Since this input is always used when UART3 input is operating, output using the port must be stopped beforehand unless this operation is the intended operation.
		PH3		General-purpose I/O port
126	103	SO3	D	Data output from UART3. This function is valid when UART3 data output is enabled.
		PH4		General-purpose I/O port. This function is valid when UART3 data output is disabled.
127	104	SCK3	D	Clock I/O for UART3. This function is valid when UART3 clock output is enabled or when an external clock input is used.
		PH5		General-purpose I/O port. This function is valid when UART3 clock output is disabled or when an external clock input is not used.
128	—	SI4	D	Data input for UART4. Since this input is always used when UART4 input is operating, output using the port must be stopped beforehand unless this operation is the intended operation.
		PG0		General-purpose I/O port
129	—	SO4	D	Data output from UART4. This function is valid when serial I/O4 data output is enabled.
		PG1		General-purpose I/O port. This function is valid when serial I/O4 data output is disabled.

(Continued)

# MB91350A Series

Pin no.		Pin name	I/O circuit type*3	Function
LQFP*1	LQFP*2			
130	—	SCK4	D	Clock I/O for UART4. This function is valid when serial I/O4 clock output is enabled or when an external clock input is used.
		PG2		General-purpose I/O port. This function is valid when serial I/O4 clock output is disabled or when an external clock input is not used.
131	—	SI5	D	Data input for serial I/O5. Since this input is always used when serial I/O5 input is operating, output using the port must be stopped beforehand unless this operation is the intended operation.
		PG3		General-purpose I/O port
132	—	SO5	D	Data output from serial I/O5. This function is valid when serial I/O5 data output is enabled.
		PG4		General-purpose I/O port. This function is valid when serial I/O5 data output is disabled.
133	—	SCK5	D	Clock I/O for serial I/O5. This function is valid when serial I/O5 clock output is enabled or when an external shift clock input is used.
		PG5		General-purpose I/O port. This function is valid when serial I/O5 clock output is disabled or when an external clock input is not used.
134	51	NMI	H	NMI (non-maskable interrupt) input
135	61	X1A	B	Clock (oscillation) output (sub clock)
137	60	X0A	B	Clock (oscillation) input (sub clock)
138 to 140	52 to 54	MD2 to MD0	H	Mode pins 2 to 0. These pins set the basic operating mode. Connect the pins to V <sub>CC</sub> or V <sub>SS</sub> .
			J	Input circuit type : The production version (MASK ROM version) is the "H" type. The Flash ROM version is the "J" type.
141	58	X0	A	Clock (oscillation) input (main clock)
143	57	X1	A	Clock (oscillation) output (main clock)
144	55	INIT	I	External reset input
147	—	DREQ2	C	DMA external transfer request input. Since this input is always used when it is selected as the DMA activation source, output using the port must be stopped beforehand unless this operation is the intended operation.
		PC0		General-purpose I/O port

(Continued)

# MB91350A Series

Pin no.		Pin name	I/O circuit type*3	Function
LQFP*1	LQFP*2			
148	—	DACK2	C	DMA external transfer request acceptance output. This function is valid when DMA transfer request acceptance output is enabled.
		PC1		General-purpose I/O port. This function is valid when DMA transfer request acceptance output is enabled.
149	—	DEOP2	C	DMA external transfer end output. This function is valid when DMA external transfer end output is enabled.
		DSTP2		DMA external transfer stop input. This function is valid when DMA external transfer stop input is enabled.
		PC2		General-purpose I/O port. This function is valid when DMA external transfer end output and external transfer stop input are disabled.
150	—	DREQ0	C	DMA external transfer request input. Since this input is always used when it is selected as the DMA activation source, output using the port must be stopped beforehand unless this operation is the intended operation.
		PB0		General-purpose I/O port
151	—	DACK0	C	DMA external transfer request acceptance output. This function is valid when DMA transfer request acceptance output is enabled.
		PB1		General-purpose I/O port. This function is valid when DMA transfer request acceptance output is disabled.
152	—	DEOP0	C	DMA external transfer end output. This function is valid when DMA external transfer end output is enabled.
		DSTP0		DMA external transfer stop input. This function is valid when DMA external transfer stop input is enabled.
		PB2		General-purpose I/O port. This function is valid when DMA external transfer end output and external transfer stop input are disabled.
153	—	DREQ1	C	DMA external transfer request input. Since this input is always used when it is selected as the DMA activation source, output using the port must be stopped beforehand unless this operation is the intended operation.
		PB3		General-purpose I/O port.

(Continued)

# MB91350A Series

Pin no.		Pin name	I/O circuit type*3	Function
LQFP*1	LQFP*2			
154	—	DACK1	C	DMA external transfer request acceptance output. This function is valid when DMA transfer request acceptance output is enabled.
		PB4		General-purpose I/O port. This function is valid when DMA external transfer request acceptance output is disabled.
155	—	DEOP1	C	DMA external transfer end output. This function is valid when DMA external transfer end output is enabled.
		DSTP1		DMA external transfer stop input. This function is valid when DMA external transfer stop input is enabled.
		PB5		General-purpose I/O port. This function is valid when DMA external transfer end output and external transfer stop input are disabled.
156	—	$\overline{\text{IOWR}}$	C	Write strobe output for DMA fly-by transfer. This function is valid when write strobe output for DMA fly-by transfer is enabled.
		PB6		General-purpose I/O port. This function is valid when write strobe output for DMA fly-by transfer is disabled.
157	—	$\overline{\text{IORD}}$	C	Read strobe output for DMA fly-by transfer. This function is valid when read strobe output for DMA fly-by transfer is enabled.
		PB7		General-purpose I/O port. This function is valid when read strobe output for DMA fly-by transfer is disabled.
158	66	$\overline{\text{CS0}}$	C	Chip select 0 output. This function is valid in external bus mode.
		PA0		General-purpose I/O port. This function is valid in single-chip mode.
159	67	$\overline{\text{CS1}}$	C	Chip select 1 output. This function is valid when chip select 1 output is enabled.
		PA1		General-purpose I/O port. This function is valid when chip select 1 output is disabled.
160	68	$\overline{\text{CS2}}$	C	Chip select 2 output. This function is valid when chip select 2 output is enabled.
		PA2		General-purpose I/O port. This function is valid when chip select 2 output is disabled.

(Continued)

# MB91350A Series

Pin no.		Pin name	I/O circuit type*3	Function
LQFP*1	LQFP*2			
161	69	$\overline{\text{CS3}}$	C	Chip select 3 output. This function is valid when chip select 3 output is enabled.
		PA3		General-purpose I/O port. This function is valid when chip select 3 output is disabled.
164	45	RDY	D	External ready input. This function is valid when external ready input is enabled.
		IN0		Input capture input pin. Since this input is always used when it is selected for input capture input, output using the port must be stopped beforehand unless this operation is the intended operation.
		P80		General-purpose I/O port. This function is valid when external ready input is disabled.
165	46	$\overline{\text{BGRNT}}$	D	External bus open acceptance output. Outputs an "L" level when the external bus is open. This function is valid when output is enabled.
		IN1		Input capture input pin. Since this input is always used when it is selected for input capture input, output using the port must be stopped beforehand unless this operation is the intended operation.
		P81		General-purpose I/O port. This function is valid when external bus open acceptance is disabled.
166	47	BRQ	D	External bus open request input. A high level is input to this pin to request for the external bus to be made open. This function is valid when input is enabled.
		IN2		Input capture input pin. Since this input is always used when it is selected for input capture input, output using the port must be stopped beforehand unless this operation is the intended operation.
		P82		General-purpose I/O port. This function is valid when external bus open request is disabled.
167	48	$\overline{\text{RD}}$	D	External bus read strobe output. This function is valid in external bus mode.
		P83		General-purpose I/O port. This function is valid in single-chip mode.

(Continued)

# MB91350A Series

(Continued)

Pin no.		Pin name	I/O circuit type*3	Function
LQFP*1	LQFP*2			
168	49	$\overline{WR0}$	D	External bus write strobe output. This function is valid in external bus mode.
		P84		General-purpose I/O port. This function is valid in single-chip mode.
169	50	$\overline{WR1}$	D	External bus write strobe output. This function is valid when $\overline{WR1}$ output in external bus mode is enabled.
		IN3		Input capture input pin. Since this input is always used when it is selected for input capture input, output using the port must be stopped beforehand unless this operation is the intended operation.
		P85		General-purpose I/O port. This function is valid when external bus write enable output is disabled.
170	62	SYSCLK	C	System clock output. This function is valid when system clock output is enabled. A clock having the same frequency as the external bus operating frequency is output (stopped in stop mode).
		P90		General-purpose I/O port. This function is valid when system clock output is disabled.
171	63	P91	C	General-purpose I/O port
172	—	MCLK	C	Memory clock output. This function is valid when memory clock output is enabled. A clock having the same frequency as the external bus operating frequency is output (stopped in sleep mode).
		P92		General-purpose I/O port. This function is valid when memory clock output is disabled.
173	64	P93	C	General-purpose I/O port
174	65	$\overline{AS}$	C	Address strobe output. This function is valid when address strobe output is enabled.
		P94		General-purpose I/O port. This function is valid when address load output is disabled.

\*1 : FPT-176P-M02

\*2 : FPT-120P-M21

\*3 : Refer to "■ I/O CIRCUIT TYPE" for details on the I/O circuit types.

\*4 : These functions are not supported on the FPT-120P-M21.

# MB91350A Series

## [Power supply and GND pins]

Pin number		Pin name	Function
LQFP*1	LQFP*2		
17, 35, 65, 79, 93, 96, 114, 136, 145, 162, 175	18, 40, 43, 59, 76, 96, 112	V <sub>SS</sub>	GND pins. Use the same potential for all pins.
18, 36, 66, 80, 97, 115, 142, 146, 163, 176	19, 44, 56, 77, 95	V <sub>CC</sub>	3.3 V power supply pins. Use the same potential for all pins.
45	107	DAVS	D/A converter GND pin
46	108	DAVC	D/A converter power supply pin
62	109	AV <sub>CC</sub>	A/D converter analog power supply pin
63	110	AVRH	A/D converter reference power supply pin
64	111	AV <sub>SS</sub> /AVRL	A/D converter analog GND pin

\*1 : FPT-176P-M02

\*2 : FPT-120P-M21

# MB91350A Series

## I/O CIRCUIT TYPE

Type	Circuit type	Remarks
A	<p>Standby control</p>	Oscillation feedback resistance : approx. 1 MΩ
B	<p>Standby control</p>	Oscillation feedback resistance for low speed (sub clock oscillation) : approx. 7 MΩ
C	<p>Pull-up control</p> <p>P-ch</p> <p>Digital output</p> <p>N-ch</p> <p>Digital output</p> <p>Standby control</p> <p>Digital input</p>	<ul style="list-style-type: none"> <li>• CMOS level output</li> <li>• CMOS level input</li> </ul> <p>With standby control</p> <p>With pull-up control</p>
D	<p>Pull-up control</p> <p>P-ch</p> <p>Digital output</p> <p>N-ch</p> <p>Digital output</p> <p>Standby control</p> <p>Digital input</p>	<ul style="list-style-type: none"> <li>• CMOS level output</li> <li>• CMOS level hysteresis input</li> </ul> <p>With standby control</p> <p>With pull-up control</p>

(Continued)

Type	Circuit type	Remarks
E	<p>Digital output</p> <p>Digital output</p> <p>Digital input</p>	<ul style="list-style-type: none"> <li>• CMOS level output</li> <li>• CMOS level hysteresis input</li> </ul> <p>Withstand voltage of 5 V</p>
F	<p>Digital output</p> <p>Digital input</p> <p>Standby control</p>	<ul style="list-style-type: none"> <li>• N-ch (Open drain input)</li> <li>• CMOS level hysteresis input</li> </ul> <p>With standby control</p> <p>Withstand voltage of 5 V</p>
G	<p>Analog input</p> <p>Control</p>	<p>Analog input</p> <p>With switch</p>
H	<p>Digital input</p>	<p>CMOS level hysteresis input</p>
I	<p>Digital input</p>	<p>CMOS level hysteresis input</p> <p>With pull-up resistor</p>

# MB91350A Series

(Continued)

(Continued)

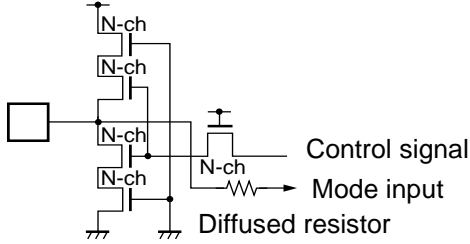
Type	Circuit type	Remarks
J	 <p>Control signal</p> <p>Mode input</p> <p>Diffused resistor</p>	<ul style="list-style-type: none"> <li>• CMOS level input</li> <li>• MB91F353A/F355A/F356B/F357B only</li> </ul>

## ■ HANDLING DEVICES

- Preventing Latch-up

Latch-up may occur in a CMOS IC if a voltage greater than  $V_{CC}$  or less than  $V_{SS}$  is applied to an input or output pin or if an above-rating voltage is applied between  $V_{CC}$  and  $V_{SS}$ . A latch-up, if it occurs, significantly increases the power supply current and may cause thermal destruction of an element. When you use a CMOS IC, don't exceed the absolute maximum rating.

- Treatment of Unused Pins

Do not leave unused input pins open, as this may cause a malfunction. Handle by using a pull-up or pull-down resistor.

- Power Supply Pins

In products with multiple  $V_{CC}$  and  $V_{SS}$  pins, the pins of the same potential are internally connected in the device to avoid abnormal operations including latch-up. However, you must connect the pins to the external power supply and ground lines in order to lower the electro-magnetic emission level, to prevent abnormal operation of strobe signals caused by the rise in the ground level, and to conform to the total output current rating. Moreover, connect the current supply source to the  $V_{CC}$  and  $V_{SS}$  pins of this device at the low impedance.

It is also advisable to connect a ceramic bypass capacitor of approximately 0.1  $\mu\text{F}$  between  $V_{CC}$  and  $V_{SS}$  pins near this device.

- Crystal Oscillator Circuit

Noise near the X0, X1, X0A and X1A pins may cause the device to malfunction. Design the printed circuit board so that X0, X1, X0A, X1A, the crystal oscillator (or ceramic oscillator), and the bypass capacitor to ground are located close to the device as possible.

It is strongly recommended that the PC board artwork be designed such that the X0, X1, X0A and X1A pins are surrounded by ground plane, as stable operation can be obtained by using this layout.

Please ask the crystal maker to evaluate the oscillational characteristics of the crystal and this device.

- Notes on Using an External Clock

When using an external clock, as a general rule you should simultaneously supply the clock signal to X0 and a clock signal with the reverse phase to X1. However, the stop mode (oscillator stop mode) must not be used under this configuration (This is because the X1 pin stops at High level output in STOP mode).

Using an external clock (normal)

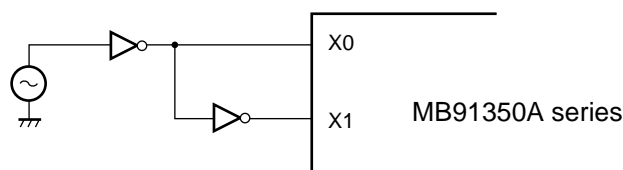

Note : STOP mode (oscillation stop mode) cannot be used.

- Clock Control Block

Hold the signal for the oscillation stabilization wait time when inputting a Low level to the  $\overline{\text{INIT}}$  pin.

# MB91350A Series

- Notes on Using the Sub Clock

When the X0A and X1A pins are not connected to an oscillator, pull down the X0A pin and leave the X1A pin open.

## Using an external clock (normal)

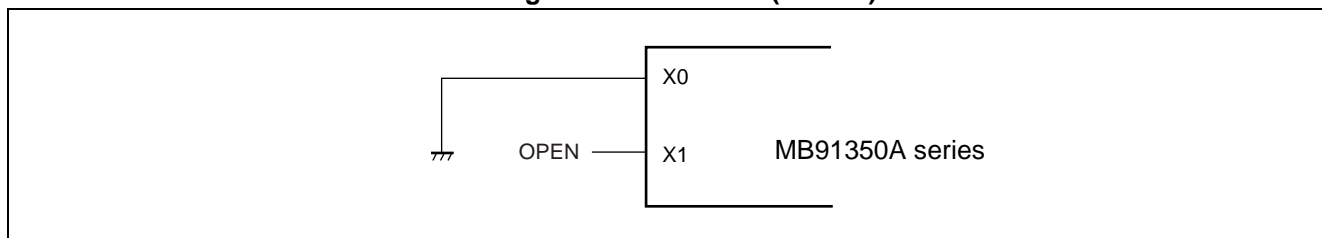

- Treatment of NC and OPEN Pins

Pins marked as NC and OPEN must be left open.

- Mode Pins (MD0 to MD2)

These pins should be connected directly to the  $V_{CC}$  or  $V_{SS}$  pins.

To prevent the device erroneously switching to test mode due to noise, design the printed circuit board such that the distance between the mode pins and  $V_{CC}$  or  $V_{SS}$  pins is as short as possible and the connection impedance is low.

- Operation at Start-up

The  $\overline{INIT}$  pin must be at Low level when the power supply is turned on.

Immediately after the power supply is turned on, the Low level input needs to be held to the  $\overline{INIT}$  pin for the oscillation stabilization wait time of the oscillator circuit to ensure that the oscillator has time to settle (For  $\overline{INIT}$  via the  $\overline{INIT}$  pin, the oscillation stabilization wait time setting is initialized to the minimum value).

- Oscillation Input at Power On

When the power is turned on, maintain the clock input until the device is released from the oscillation stabilization wait state.

- Precautions While Operating in PLL Clock Mode

On this microcontroller, if the crystal oscillator is disconnected or the external reference clock input stops while PLL clock mode is selected, the microcontroller may continue to operate at the free-run frequency of the self-oscillating circuit within the PLL. However, Fujitsu does not guarantee this operation.

- External Bus Setting

This model guarantees an external bus frequency of 25 MHz.

If the base clock frequency is set to 50 MHz when the DIVR1 (external bus base clock division setting register) register is still set to the default value, the external bus frequency will be set to 50 MHz. When you change the base clock frequency, change the base clock frequency after setting the external bus within 25 MHz.

- MCLK and SYSCLK

The difference between MCLK and SYSCLK is that MCLK stops in SLEEP/STOP mode but SYSCLK stops only in STOP mode. Use the clock that is appropriate for each application.

Upon initialization, MCLK is disabled (PORT) and SYSCLK is enabled. To use MCLK, the port function register (PFR) needs to be set to enable the use of the clock.

- Pull-up Control

If a pull-up resistor is provided to a pin that is used as an external bus pin, there is no guarantee that the pin will conform to the specifications given in “■ ELECTRICAL CHARACTERISTICS 4. AC Characteristics (4) Normal Bus Access Read/Write Operation, (5) Multiplex Bus Access Read/Write operation and (7) Hold Timing”. Furthermore, even if a port has been configured to use a pull-up resistance, this setting is invalid during stop mode with HIZ=1 and during hardware standby mode.

- Sub Clock Select

At least one NOP instruction needs to be executed immediately after switching the clock source from main clock mode to sub clock mode.

```
(ldi #0x0b, r0)
(ldi #_CLKR, r12)
stb r0, @r12 // sub-clock mode
nop // Must insert NOP instruction
```

- Bit Search Module

The BSD0, BSD1, and BDSC registers can only be accessed in words.

- D-bus Memory

Do not set the code area to memory on the D-bus because instructions cannot be fetched from the D-bus. Executing an instruction fetch to the D-bus area will cause incorrect data to be interpreted as code, possibly causing the device to run out of control.

- Low Power Consumption Mode

When entering sleep or stop mode, be sure to read the standby control register (STCR) immediately after writing to it.

More specifically, use the following sequence.

Furthermore, after recovering from standby mode, set the I flag, ILM, and ICR registers such that the CPU branches to the interrupt handler for the interrupt that triggered the controller to recover from standby mode.

```
(ldi #value_of_standby, r0)
(ldi #_STCR, r12)
stb r0, @r12 // set STOP/SLEEP bit
ldub @r12, r0 // Must read STCR
ldub @r12, r0 // after reading, go into standby mode
NOP // Must insert NOP × 5
NOP
NOP
NOP
NOP
```

- Switching the Function of Shared Ports

Use the Port Function Register (PFR) to switch between using an external pin as a port or a shared pin. Note, however, that bus pins are switched depending on the external bus settings.

# MB91350A Series

- Prefetch

If prefetch is enabled in a area that is configured as little endian, limit access to the corresponding area to word-length (32-bit) access.

Byte or halfword does not allow a proper access to data.

- I/O Port Access

Ports can only be accessed in bytes.

- Built-in RAM

Immediately after a reset is released, the internal RAM capacity restriction function begins operating, allowing only 4 Kbytes to be used for both data and program execution irrespective of the on-chip RAM capacity.

Update the setting to clear the restriction function.

At least one NOP instruction is required immediately after updating this setting.

Please refer to the “MB91350A Series HARDWARE MANUAL CHAPTER 19 DATA INTERNAL RAM/INSTRUCTION INTERNAL RAM ACCESS RESTRICTION FUNCTIONS” for the details.

- Flash Memory

In programming mode, Flash memory cannot be used for the interrupt vector table (However, a reset can be performed) .

- Notes on the PS Register

As the PS register is processed in advance by some instructions, when the debugger is being used, the following exception handling may result in execution breaking in an interrupt handling routine or the displayed values of the flags in the PS register being updated.

As the microcontroller is designed to carry out reprocessing correctly upon returning from such an EIT event, the operation before and after the EIT always proceeds according to specification.

1. The following behavior may occur if any of the following occurs in the instruction immediately after a DIV0U/DIV0S instruction :

(a) a user interrupt or NMI is accepted; (b) single-step execution is performed; or (c) execution breaks due to a data event or from the emulator menu.

- The D0 and D1 flags are updated in advance.
- An EIT handling routine (user interrupt, NMI, or emulator) is executed.
- Upon returning from the EIT, the DIV0U/DIV0S instruction is executed and the D0 and D1 flags are updated to the same values as in (1).

2. The following behavior occurs when an ORCCR, STILM, MOV Ri or PS instruction is executed to enable a user interrupt or NMI source while that interrupt is in the active state.

- The PS register is updated in advance.
- The EIT handling routine (user interrupt, NMI, or emulator) is executed.
- Upon returning from the EIT, the above instructions are executed and the PS register is updated to the same value as in (1).

## [Note on Debugger]

- Single-Step Execution of the RETI Command

If single-step execution is used in an environment where an interrupt occurs frequently, the corresponding interrupt handling routine will be executed repeatedly to the exclusion of other processing. This will prevent the main routine and the handlers for low priority level interrupts from being executed (For example, if the time-base timer interrupt is enabled, stepping over the RETI instruction will always break on the first line of the time-base timer interrupt handler) .

Disable the corresponding interrupt when the corresponding interrupt handling routine no longer needs debugging.

- Break Function

If the range of addresses that cause a hardware break (including event breaks) is set to the address of the current system stack pointer or to an area that contains the stack pointer, execution will break after each instruction regardless of whether the user program actually contains data access instructions.

To prevent this, do not set (word) access to the area containing the address of the system stack pointer as the target of the hardware break (including event breaks).

- Internal ROM area

Do not set DMAC transfer destination to an address in the internal ROM area.

- Simultaneous Occurrence of a Software Break (INTE instruction) and a User Interrupt/NMI

When a software break and a user interrupt/NMI occur simultaneously, the emulator debugger may react as follows.

- The debugger stops pointing to a location other than a programmed breakpoint.
- The program does not resume execution correctly after breaking.  
If this symptom occurs, use a hardware break in place of the software break. When using a monitor debugger, do not set a break at the relevant location.
- A malfunction may occur if the stack pointer is in an area that is configured for DSU operand break. Do not set a data event breaks that apply to accesses to an area that contains the address of the system stack pointer.

# MB91350A Series

## ■ BLOCK DIAGRAMS

• MB91F353A/353A/352A/351A

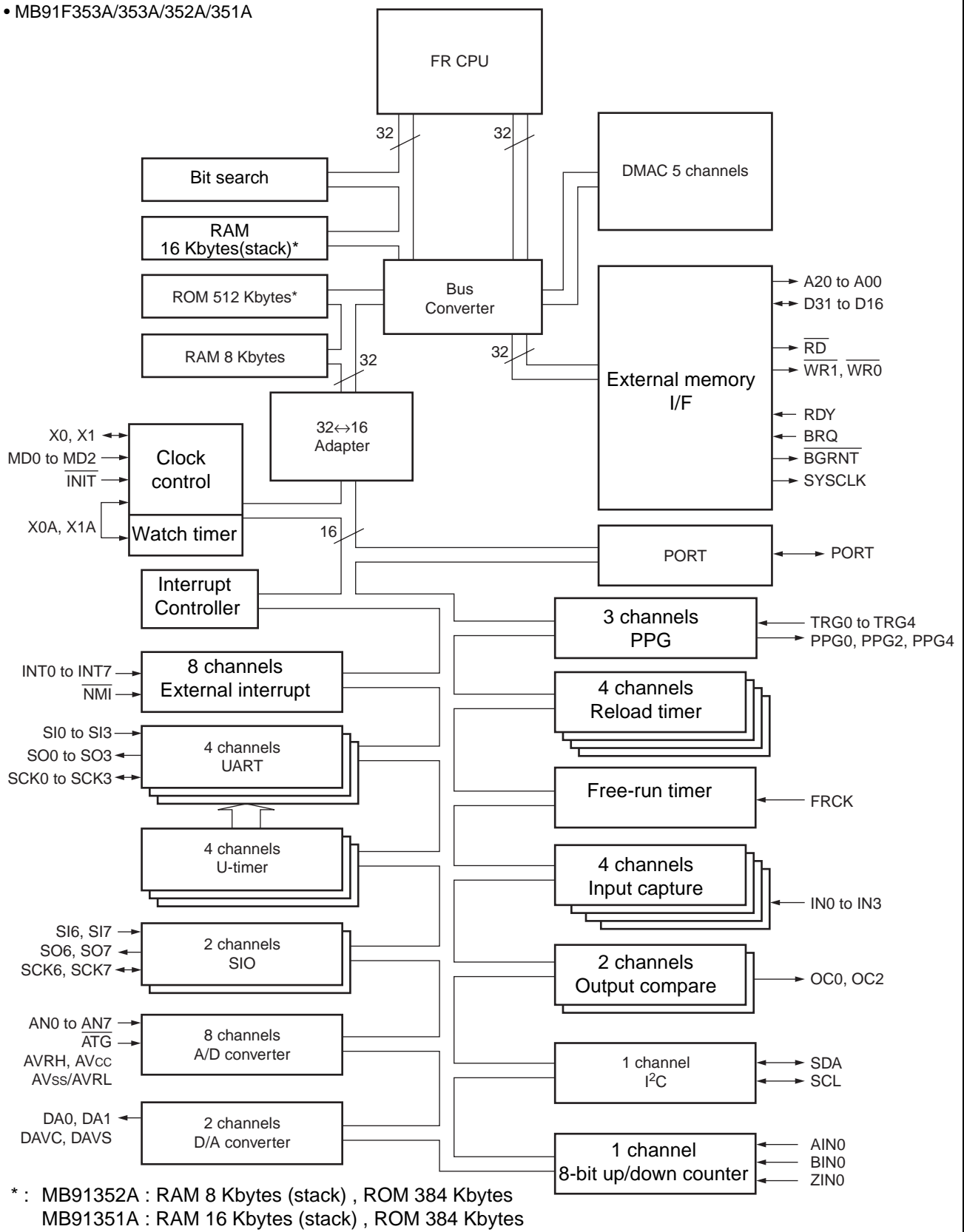

# MB91350A Series

• MB91F355A/F356B/F357B/355A/354A

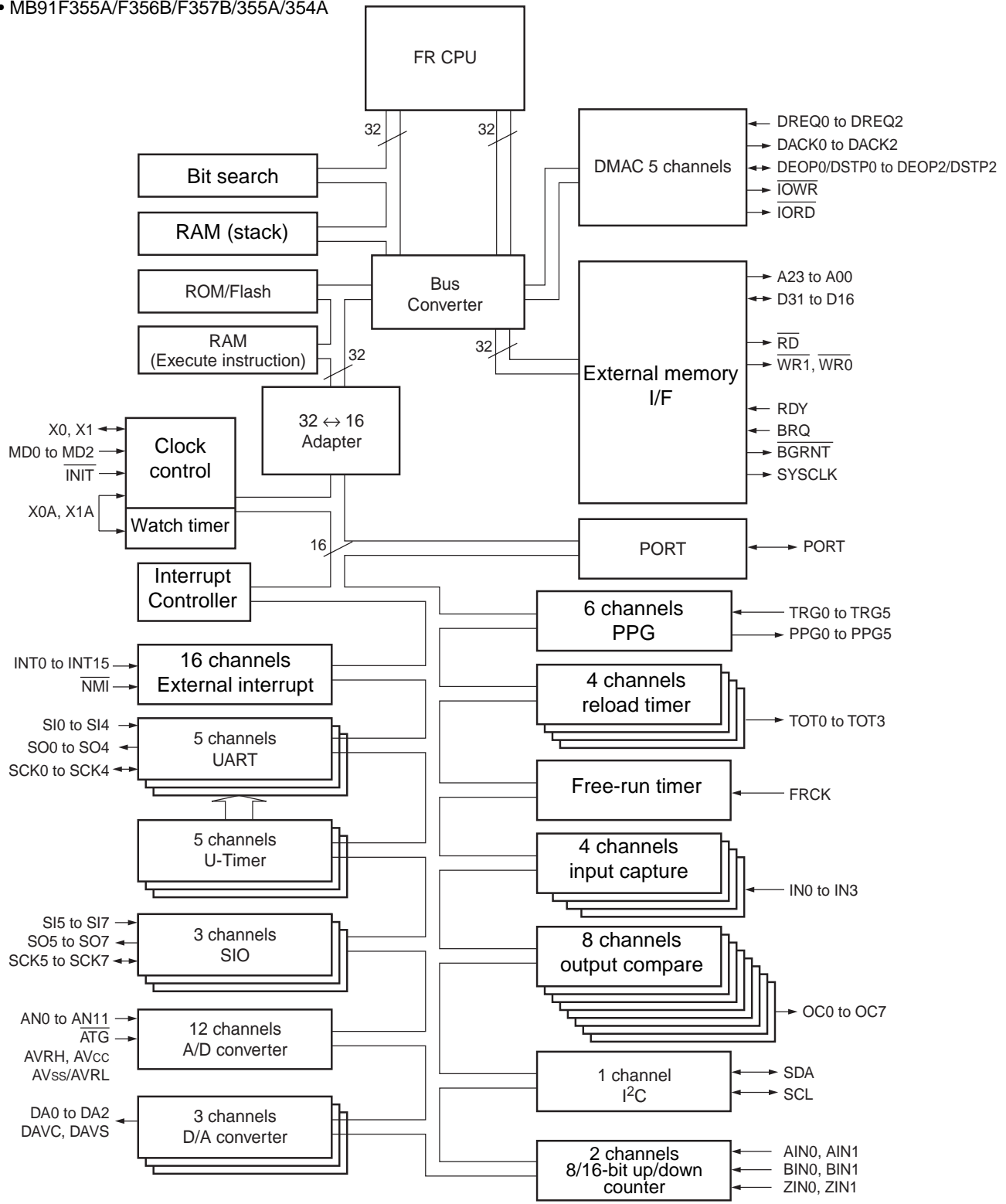

	MB91F355A/MB91F357B	MB91F356B	MB91355A	MB91354A
ROM/Flash	512 Kbytes (Flash)	256 Kbytes (Flash)	512 Kbytes	384 Kbytes
RAM (stack)	16 Kbytes	16 Kbytes	16 Kbytes	8 Kbytes
RAM (Execute instruction)	8 Kbytes	8 Kbytes	8 Kbytes	8 Kbytes

## ■ CPU AND CONTROL UNIT

### Internal architecture

The FR family CPU is a high performance core based on a RISC architecture while incorporating advanced instructions for embedded controller applications.

### 1. Features

- RISC architecture  
Basic instructions : Executed at 1 instruction per cycle
- 32-bit architecture  
General-purpose registers : 32-bit × 16 registers
- 4GB linear memory space
- Built-in multiplier  
32-bit × 32-bit multiplication : 5 cycles  
16-bit × 16-bit multiplication : 3 cycles
- Enhanced interrupt handling  
Fast response speed (6 cycles)  
Multiple interrupts supported  
Level masking (16 levels)
- Enhanced I/O manipulation instructions  
Memory-to-memory transfer instructions  
Bit manipulation instructions
- High code efficiency  
Basic instruction word length : 16-bit
- Low-power consumption  
Sleep mode and stop mode
- Gear function

## 2. Internal architecture

The FR-family CPU has a Harvard architecture in which the instruction and data buses are separated. A 32-bit ↔ 16-bit bus converter is connected to the 32-bit bus (F-bus), providing an interface between the CPU and peripheral resources. A Harvard ↔ Princeton bus converter is connected to both the I-bus and D-bus, providing an interface between the CPU and the bus controller.

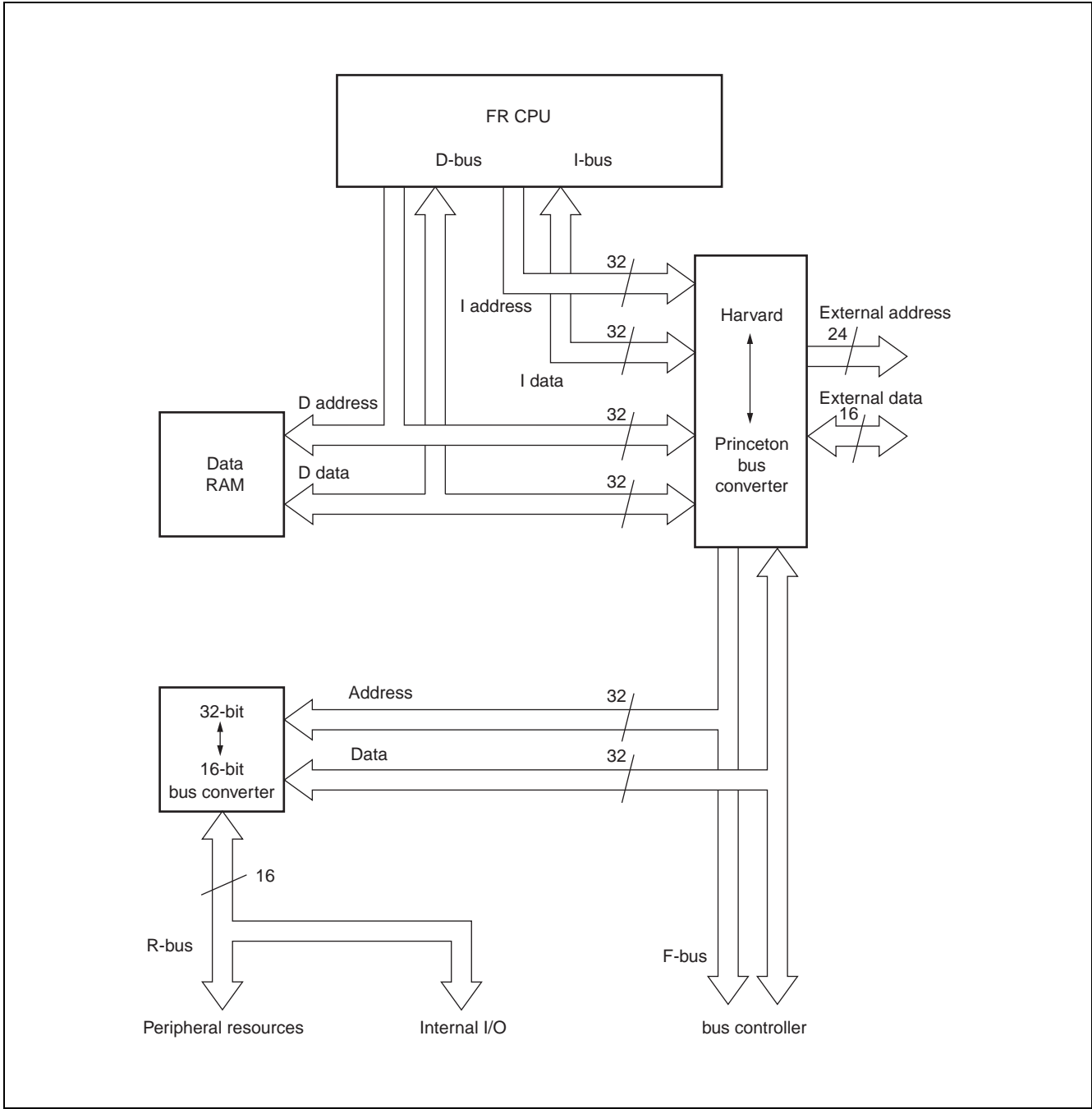

# MB91350A Series

## 3. Programming model

- Basic programming model

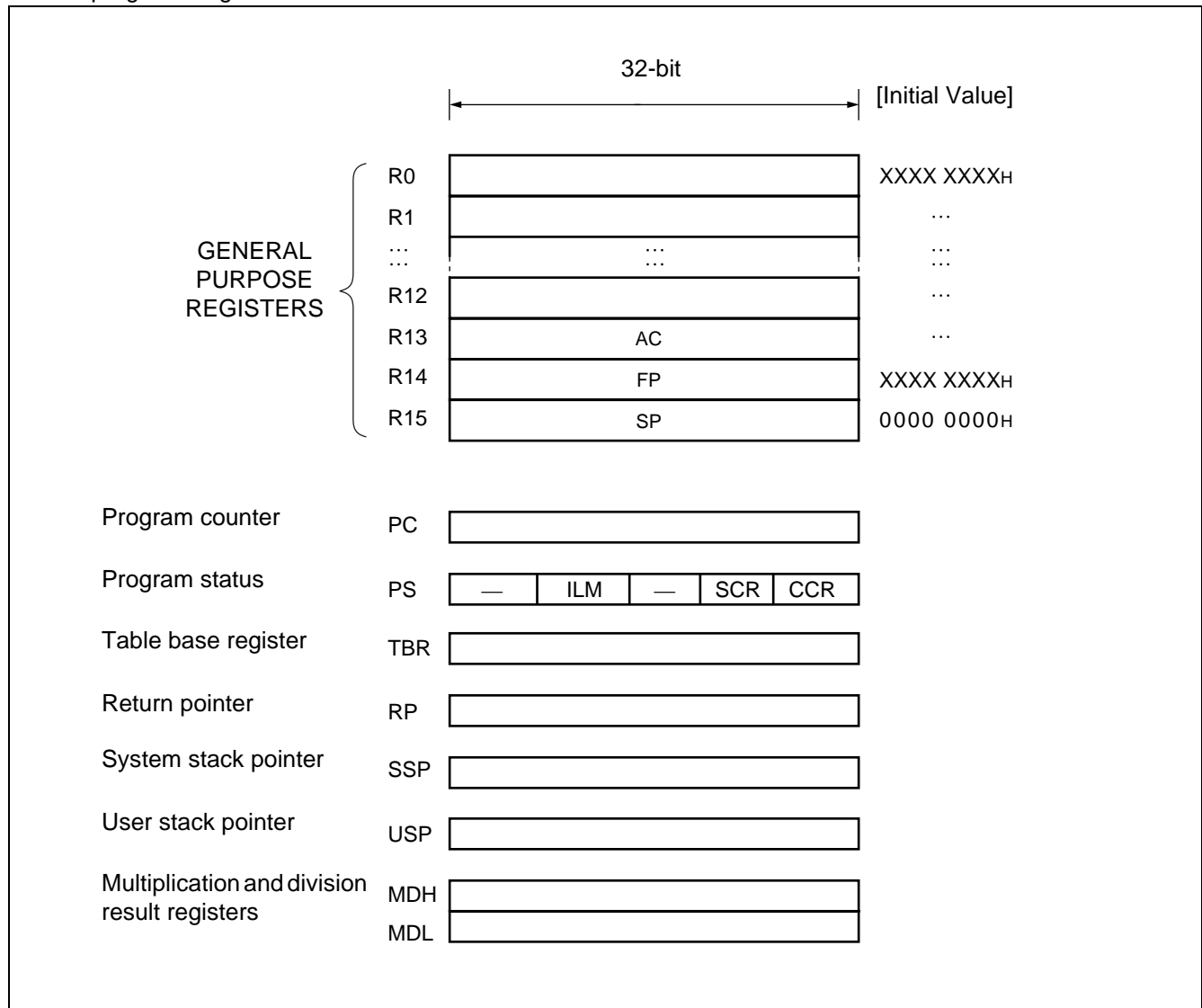

## 4. Registers

- General purpose registers

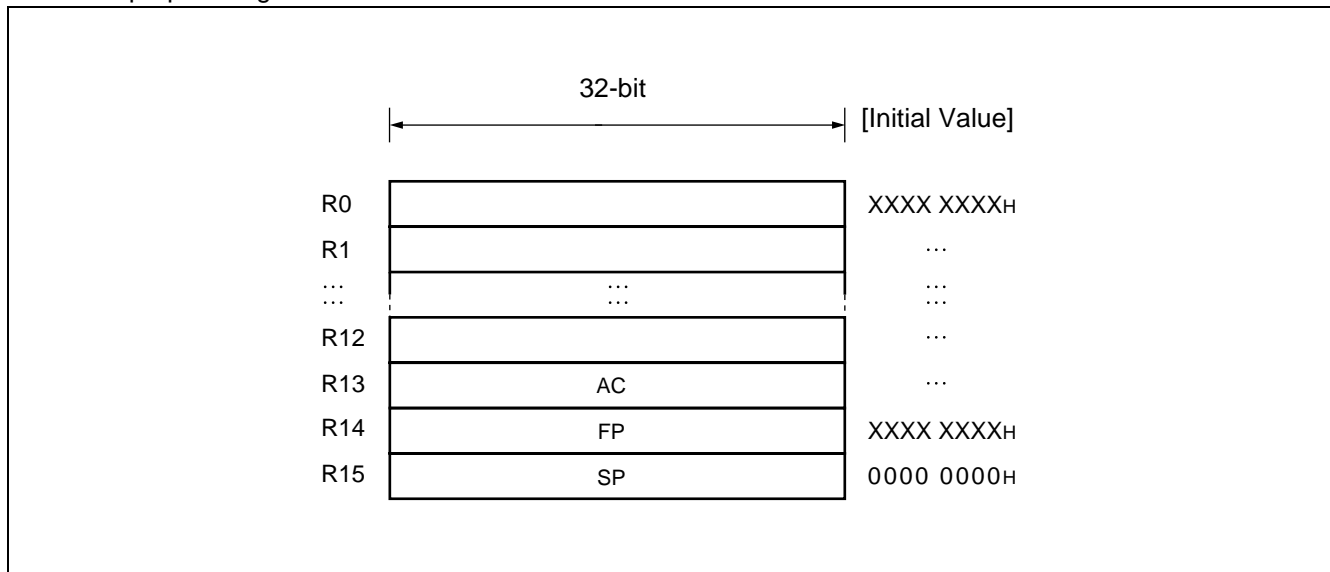

Registers R0 to R15 are general-purpose registers. The registers are used as the accumulator and memory access pointers for CPU operations.

Of these 16 registers, the registers listed below are intended for special applications. Some instructions have been enhanced for this purpose.

- R13 : Virtual accumulator
- R14 : Frame pointer
- R15 : Stack pointer

The initial values of R0 to R14 after a reset are indeterminate. R15 is initialized to 00000000H (SSP value).

- PS (Program Status)

This register holds the program status and is divided into the ILM, SCR, and CCR.

The undefined bits in the following illustration are all reserved bits. Reading these bits always returns "0". Writing to them has no effect.

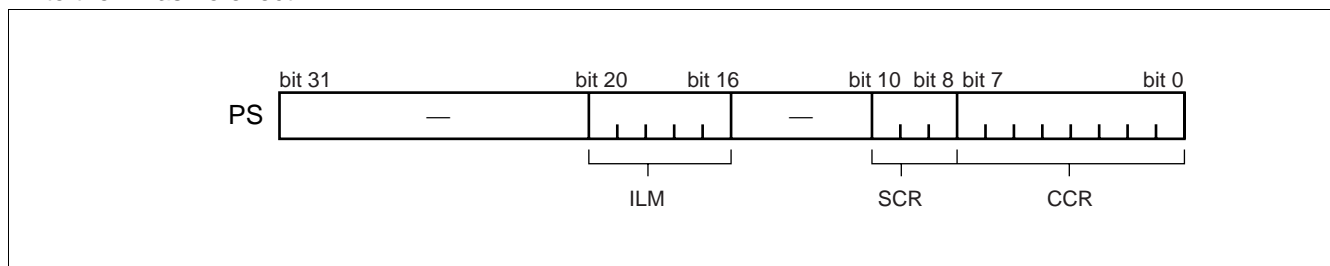

# MB91350A Series

- CCR (Condition Code Register)

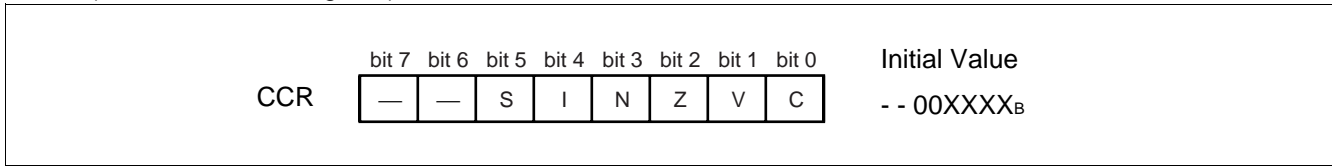

- S : Stack flag. Cleared to “0” by a reset.
- I : Interrupt enable flag. Cleared to “0” by a reset.
- N : Negative flag. The initial value after a reset is indeterminate.
- Z : Zero flag. The initial value after a reset is indeterminate.
- V : Overflow flag. The initial value after a reset is indeterminate.
- C : Carry flag. The initial value after a reset is indeterminate.

- SCR (System Condition Code Register)

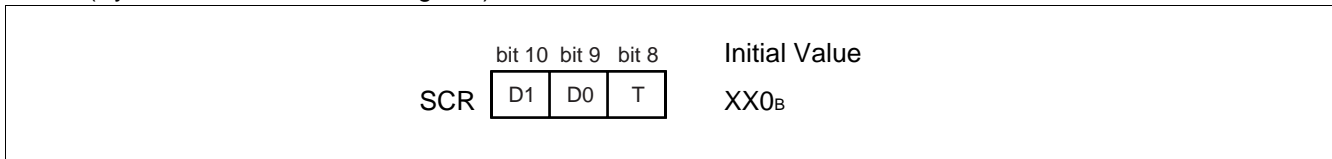

Flag for stepwise division

Stores intermediate data for stepwise division operations.

Step trace trap flag

A flag specifying whether the step trace trap function is enabled or not.

The step trace trap function is used by the emulator. This function cannot be used by a user program while using the emulator.

- ILM

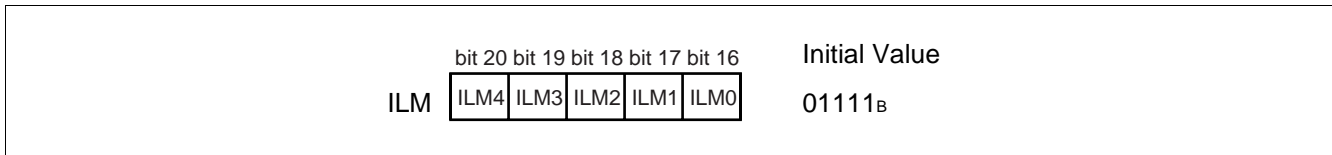

This register stores the interrupt level mask value. The value in the ILM register is used as the level mask. Initialized to “15” (01111<sub>B</sub>) by a reset.

- PC (Program Counter)

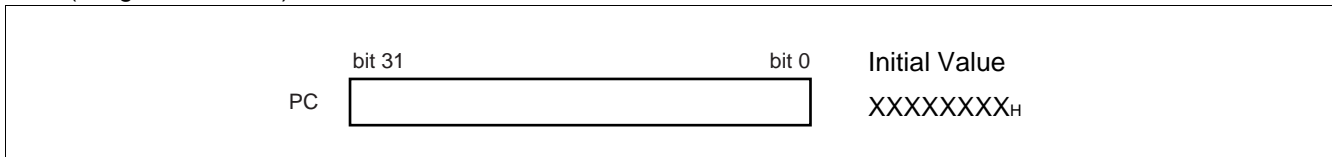

The program counter contains the address of the instruction currently being executed. The initial value after a reset is indeterminate.

- TBR (Table Base Register)

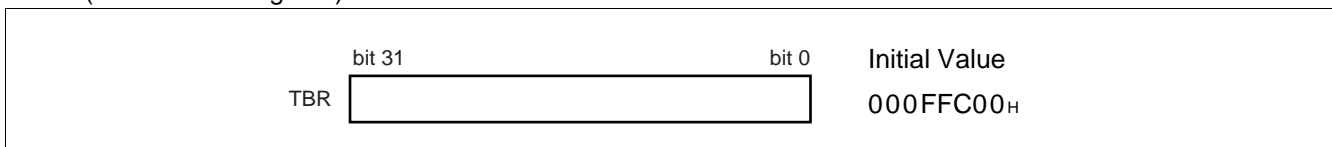

The table base register contains the start address of the vector table used for handling EIT events. The initial value after a reset is 000FFC00<sub>H</sub>.

- RP (Return Pointer)

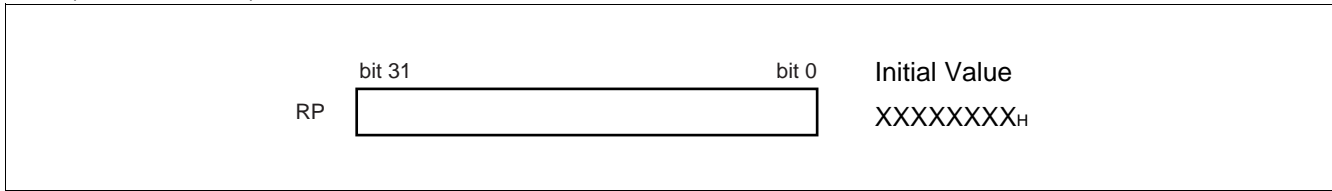

The return pointer contains the address to which to return from a subroutine. When the CALL instruction is executed, the value in the PC is transferred to the RP. When the RET instruction is executed, the value in the RP is transferred to the PC. The initial value after a reset is indeterminate.

- SSP (System Stack Pointer)

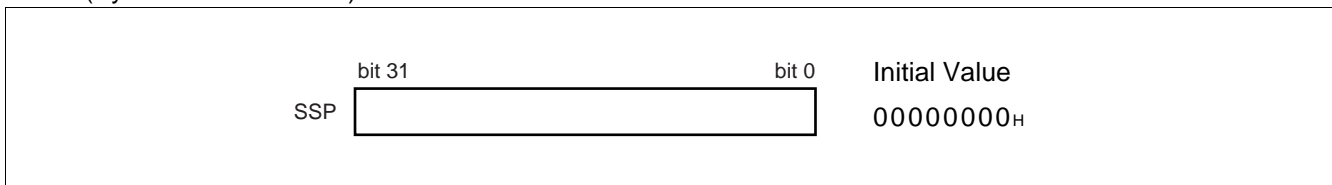

The SSP is the system stack pointer and functions as R15 when the S flag is “0”. The SSP can be specified explicitly. The SSP is also used as the stack pointer that specifies the stack for saving the PS and PC when an EIT event occurs. The initial value after a reset is 00000000<sub>H</sub>.

- USP (User Stack Pointer)

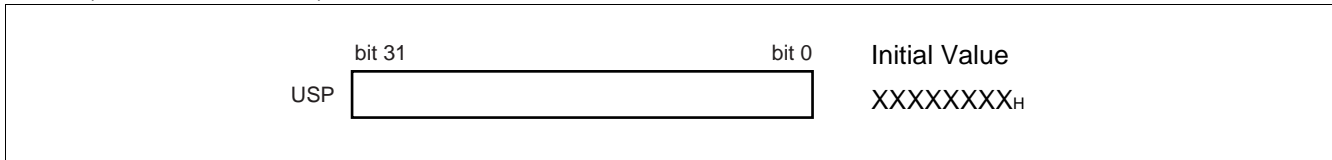

The USP is the user stack pointer and functions as R15 when the S flag is “1”. The USP can be specified explicitly. The initial value after a reset is indeterminate. This pointer cannot be used by the RETI instruction.

- Multiply & Divide Registers

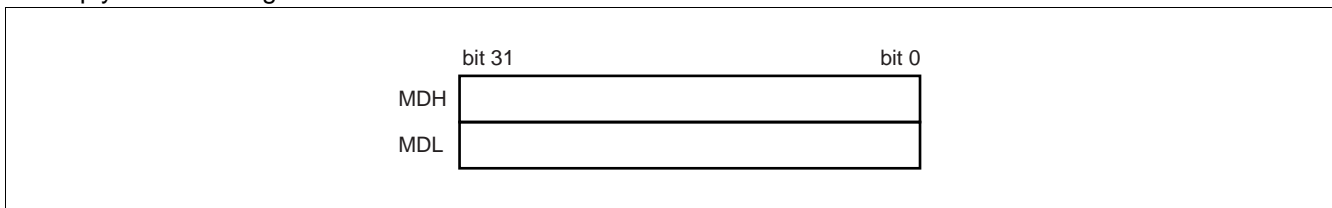

These registers are 32-bit wide registers that store the results of multiplication and division operations. The initial value after a reset is indeterminate.

# MB91350A Series

## MODE SETTINGS

The FR family uses mode pins (MD2 to MD0) and a mode register (MODR) to set the operation mode.

### 1. Mode Pins

The MD2, MD1, and MD0 pins specify how the mode vector fetch is performed.

Mode Pins			Mode name	Reset vector access area	Remarks
MD2	MD1	MD0			
0	0	0	internal ROM mode vector	Internal	
0	0	1	external ROM mode vector	External	The bus width is specified by the mode register.

Values other than those listed in the table are prohibited.

### 2. Mode Register (MODR)

The data that is written to the mode register from the address at 000F FFF8<sub>H</sub> by the mode vector fetch is called the mode data.

After the mode register (MODR), has been set, the device operates according to the configured operating mode.

The mode register is set by all of the reset sources. User programs cannot write to the mode register.

Note : No data exists at the address (0000 07FF<sub>H</sub>) of the mode register in the previous FR family.

#### [Register description]

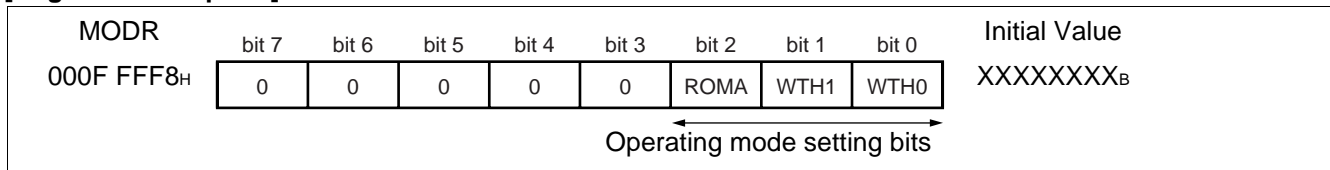

#### [bit7-bit3] Reserved bit

Always set these bits to “00000<sub>B</sub>”. Operation is not guaranteed if these bits are set to a value other than “00000<sub>B</sub>”.

#### [bit2] ROMA (internal ROM enable bit)

The ROMA bit is used to set whether to enable the internal F-bus RAM and F-bus ROM areas.

ROMA	Function	Remarks
0	External ROM mode	Internal F-bus RAM is valid; the area (8 0000 <sub>H</sub> to 10 0000 <sub>H</sub> ) of internal ROM is used as an external area.
1	Internal ROM mode	Internal F-bus RAM and F-bus ROM are valid.

#### [bit1, bit0] WTH1, WTH0 (Bus width setting bits)

Used to set the bus width to be used in external bus mode.

In external bus mode, the BW1 and BW0 bits of AMD0 (CS0 area) are set to the value of these bits.

WTH1	WTH0	function	Remarks
0	0	8-bit bus width	external bus mode
0	1	16-bit bus width	
1	0	—	Setting prohibited
1	1	single chip mode	single chip mode

## ■ MEMORY SPACE

### 1. Memory space

The FR family has 4 Gbytes of logical address space ( $2^{32}$  addresses) available to the CPU by linear access.

#### • Direct Addressing Areas

The following address space areas are used as I/O areas.

These areas are called direct addressing areas. The addresses of operands in these areas can be specified directly within an instruction.

The size of the directly addressable areas depends on the size of the data being accessed as shown below.

- Byte data access : 000<sub>H</sub> to 0FF<sub>H</sub>
- Half word data access : 000<sub>H</sub> to 1FF<sub>H</sub>
- Word data access : 000<sub>H</sub> to 3FF<sub>H</sub>

### 2. Memory Map

#### Memory Map of MB91F355A/F353A/F357B/355A/353A

	Single chip mode	Internal ROM external bus mode	External ROM external bus mode	
0000 0000 <sub>H</sub> --	I/O	I/O	I/O	Direct addressing area
0000 0400 <sub>H</sub> --	I/O	I/O	I/O	
0001 0000 <sub>H</sub> --	Access disabled	Access disabled	Access disabled	Refer to "■ I/O MAP".
0003 E000 <sub>H</sub> --	Built-in RAM 8 Kbytes (Execute instruction)	Built-in RAM 8 Kbytes (Execute instruction)	Built-in RAM 8 Kbytes (Execute instruction)	
0004 0000 <sub>H</sub> --	Built-in RAM 16 Kbytes (Stack)	Built-in RAM 16 Kbytes (Stack)	Built-in RAM 16 Kbytes (Stack)	
0004 4000 <sub>H</sub> --	Access disabled	Access disabled	Access disabled	
0005 0000 <sub>H</sub> --		External area		
0008 0000 <sub>H</sub> --	Built-in ROM 512 Kbytes	Built-in ROM 512 Kbytes	External area	
0010 0000 <sub>H</sub> --	Access disabled	External area		
FFFF FFFF <sub>H</sub> --				

- Each mode is set depending on the mode vector fetch after  $\overline{\text{INIT}}$  is negated.
- The available area of internal RAM is restricted immediately after a reset is released. At least one NOP instruction is required immediately after overwriting the setting for the available RAM area.

# MB91350A Series

Memory Map of MB91354A

	Single chip mode	Internal ROM external bus mode	External ROM external bus mode	
0000 0000 <sub>H</sub> ---	I/O	I/O	I/O	] Direct addressing area Refer to "■ I/O MAP".
0000 0400 <sub>H</sub> ---	I/O	I/O	I/O	
0001 0000 <sub>H</sub> ---	Access disabled	Access disabled	Access disabled	
0003 E000 <sub>H</sub> ---	Built-in RAM 8 Kbytes (Execute instruction)	Built-in RAM 8 Kbytes (Execute instruction)	Built-in RAM 8 Kbytes (Execute instruction)	
0004 0000 <sub>H</sub> ---	Built-in RAM 8 Kbytes (Stack)	Built-in RAM 8 Kbytes (Stack)	Built-in RAM 8 Kbytes (Stack)	
0004 2000 <sub>H</sub> ---	Access disabled	Access disabled	Access disabled	
0005 0000 <sub>H</sub> ---			External area	External area
0008 0000 <sub>H</sub> ---		Access disabled		
000A 0000 <sub>H</sub> ---	Built-in ROM 384 Kbytes	Built-in ROM 384 Kbytes		
0010 0000 <sub>H</sub> ---	Access disabled	External area		
FFFF FFFF <sub>H</sub>				

- Each mode is set depending on the mode vector fetch after  $\overline{INIT}$  is negated.
- The available area of internal RAM is restricted immediately after a reset is released. At least one NOP instruction is required immediately after overwriting the setting for the available RAM area.

## Memory Map of MB91352A

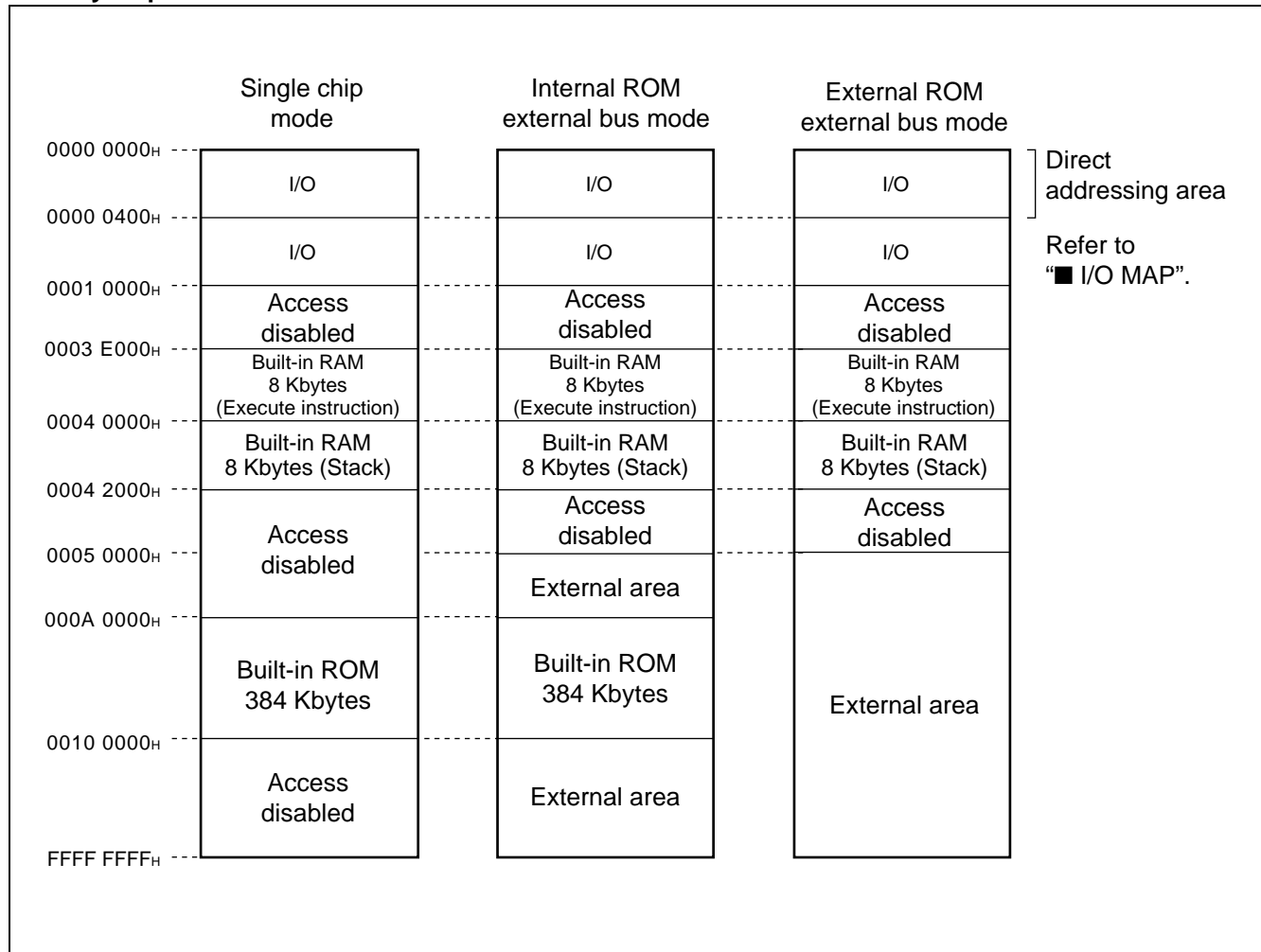

- Each mode is set depending on the mode vector fetch after  $\overline{\text{INIT}}$  is negated.
- The available area of internal RAM is restricted immediately after a reset is released. At least one NOP instruction is required immediately after overwriting the setting for the available RAM area.

# MB91350A Series

Memory Map of MB91351A

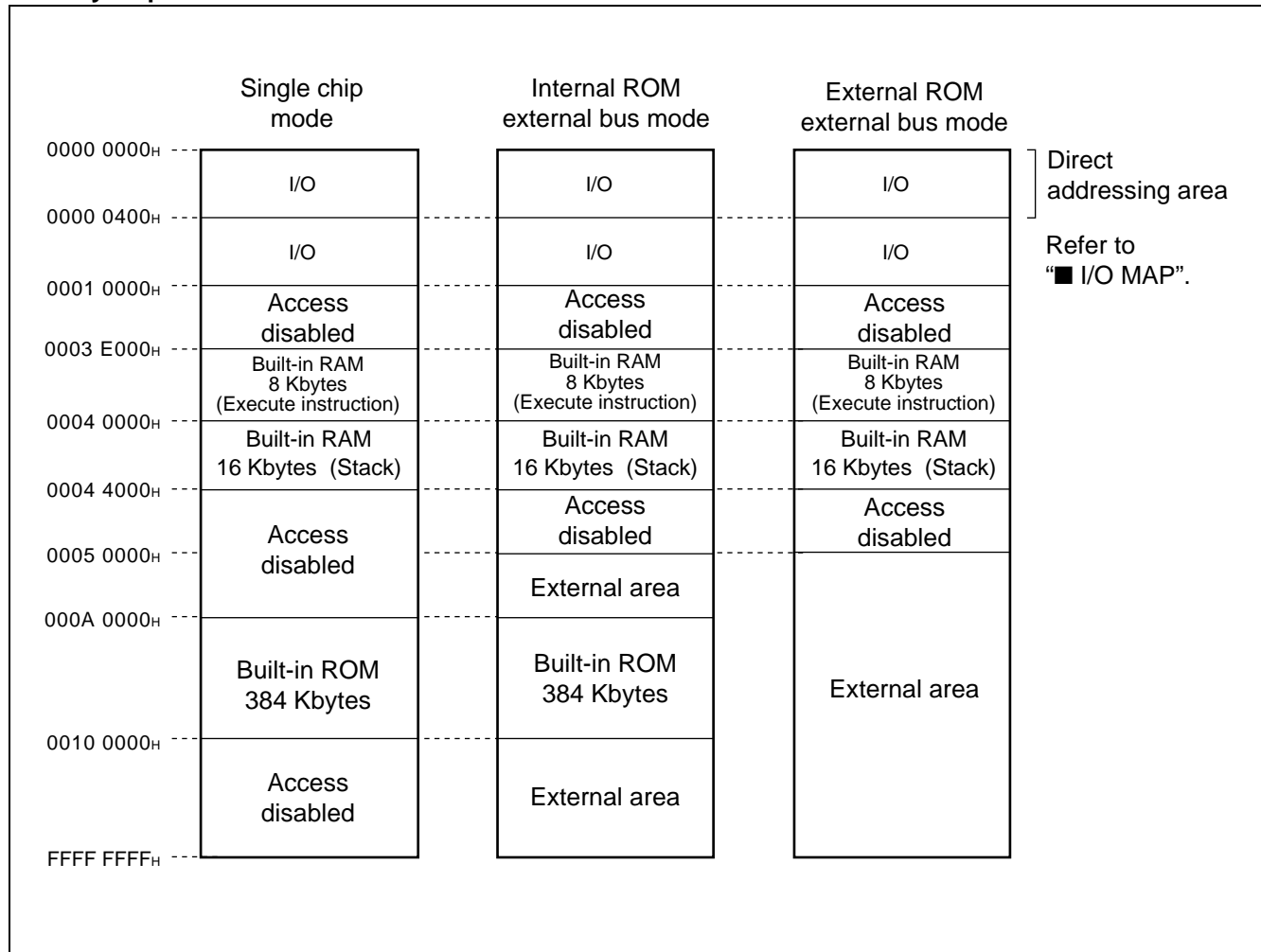

- Each mode is set depending on the mode vector fetch after  $\overline{\text{INIT}}$  is negated.
- The available area of internal RAM is restricted immediately after a reset is released. At least one NOP instruction is required immediately after overwriting the setting for the available RAM area.

## Memory Map of MB91F356B

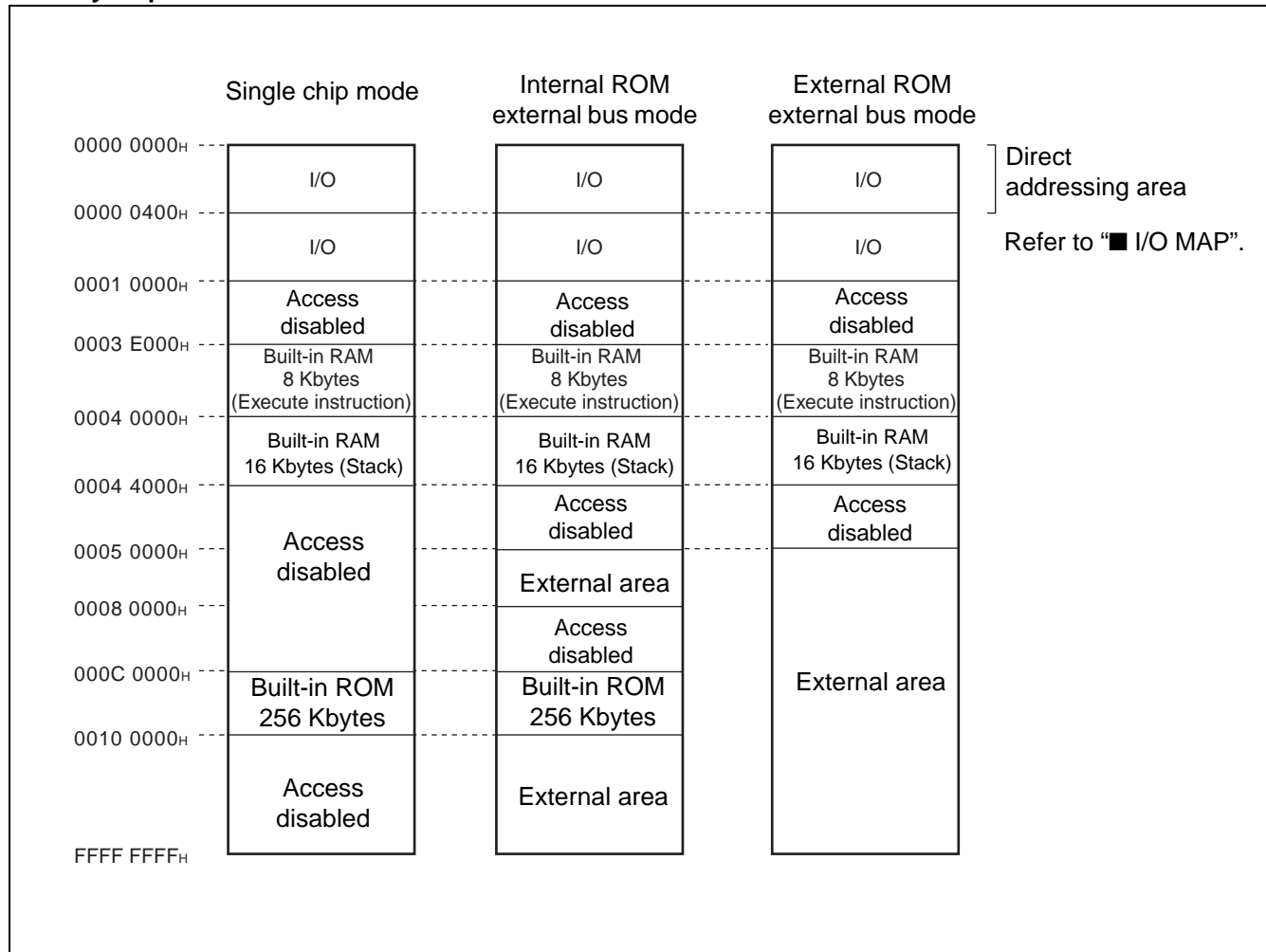

- Each mode is set depending on the mode vector fetch after  $\overline{\text{INIT}}$  is negated.
- The available area of internal RAM is restricted immediately after a reset is released. At least one NOP instruction is required immediately after overwriting the setting for the available RAM area.

# MB91350A Series

## ■ I/O MAP

This shows the locations of each of the registers for the peripheral resources in memory space.

[How to read the table]

Address	Register				Block diagram
	+ 0	+ 1	+ 2	+ 3	
000000 <sub>H</sub>	PDR0 [R/W] B ↑XXXXXXXX↑	PDR1 [R/W] B XXXXXXXX	PDR2 [R/W] B XXXXXXXX	PDR3 [R/W] B XXXXXXXX	T-unit Port Data Register

Read/write attribute, Access unit  
 (B : Byte, H : Half Word, W : Word)

Initial value after a reset

Register name (First-column register at address 4n; second-column register at address 4n + 2)

Location of left-most register (When using word access, the register in column 1 is the MSB side of the data.)

Note : Initial values of register bits are represented as follows :

- “1” : Initial value is “1”.
- “0” : Initial value is “0”.
- “X” : Initial value is “X”.
- “\_” : No physical register at this location

# MB91350A Series

Address	Register				Block
	+0	+1	+2	+3	
00000H	_____	_____	PDR2[R/W]B XXXXXXXX	PDR3[R/W]B XXXXXXXX	T-unit port data register*3
00004H	PDR4[R/W]B XXXXXXXX	PDR5[R/W]B XXXXXXXX	PDR6[R/W]B XXXXXXXX	_____	
00008H	PDR8[R/W]B --XXXXXX	PDR9[R/W]B ---XXXXX	PDRA[R/W]B ----XXXX	PDRB[R/W]B*3 XXXXXXXX	
0000CH	PDRC[R/W]B*3 ----XXX	_____			
00010H	PDRG[R/W]B*3 --XXXXXX	PDRH[R/W]B --XXXXXX	PDRI[R/W]B --XXXXXX	PDRJ[R/W]B*3 XXXXXXXX	R-bus port data register*3
00014H	PDRK[R/W]B XXXXXXXX	PDLR[L/W]B -----XX	PDRM[R/W]B --XXXXXX	PDRN[R/W]B --XXXXXX	
00018H	PDRO[R/W]B XXXXXXXX	PDRP[R/W]B*3 ----XXXX	_____	_____	
0001CH	_____				
00020H	_____	_____	_____	_____	Reserved
00024H	SMCS5[R/W]B,H*3 0000010_----00--		SES5[R/W]B*3 -----00	SDR5[R/W]B*3 XXXXXXXX	SIO5*3
00028H	SMCS6[R/W]B,H 0000010_----00--		SES6[R/W]B -----00	SDR6[R/W]B XXXXXXXX	SIO6
0002CH	SMCS7[R/W]B,H 0000010_----00--		SES7[R/W]B -----00	SDR7[R/W]B XXXXXXXX	SIO7
00030H	_____	_____	CDCR5[R/W]B*3 0---1111	_____ *1	SIO prescaler 5*3
00034H	CDCR6[R/W]B 0---1111	_____ *1	CDCR7[R/W]B 0---1111	_____ *1	SIO prescaler 6, 7
00038H	_____	SRCL5[W]B*3 -----	SRCL6[W]B -----	SRCL7[W]B -----	SIO5 to SIO7*3
0003CH	_____	_____	_____	_____	Reserved
00040H	EIRR0[R/W]B,H,W 00000000	ENIR0[R/W]B,H,W 00000000	ELVR0[R/W]B,H,W 00000000		External interrupts (INT0 to INT7)
00044H	DICR[R/W]B,H,W -----0	HRCL[R/W]B,H,W 0-11111	_____		Delay interrupt
00048H	TMRLR[W]H,W XXXXXXXX_XXXXXXXX		TMR[R]H,W XXXXXXXX_XXXXXXXX		Reload timer 0
0004CH	_____		TMCSR[R/W]B,H,W ----0000_00000000		

(Continued)

# MB91350A Series

Address	Register				Block
	+0	+1	+2	+3	
000050H	TMRLR[R/W]H,W XXXXXXXXX_XXXXXXXX		TMR[R]H,W XXXXXXXXX_XXXXXXXX		Reload timer 1
000054H	_____		TMCSR[R/W]B,H,W ----0000_00000000		
000058H	TMRLR[R/W]H,W XXXXXXXXX_XXXXXXXX		TMR[R]H,W XXXXXXXXX_XXXXXXXX		Reload timer 2
00005CH	_____		TMCSR[R/W]B,H,W ----0000_00000000		
000060H	SSR[R/W]B,H,W 00001000	SIDR[R/W]B,H,W XXXXXXXXX	SCR[R/W]B,H,W 00000100	SMR[R/W]B,H,W 00--0---	UART0
000064H	UTIM[R]H(UTIMR[W]H) 00000000_00000000		DRCL[W]B -----	UTIMC[R/W]B 0--00001	U-TIMER/ UART0
000068H	SSR[R/W]B,H,W 00001000	SIDR/SODR [R/W]B,H,W XXXXXXXXX	SCR[R/W]B,H,W 00000100	SMR[R/W]B,H,W 00--0---	UART1
00006CH	UTIM[R]H(UTIMR[W]H) 00000000_00000000		DRCL[W]B -----	UTIMC[R/W]B 0--00001	U-TIMER/ UART1
000070H	SSR[R/W]B,H,W 00001000	SIDR[R/W]B,H,W XXXXXXXXX	SCR[R/W]B,H,W 00000100	SMR[R/W]B,H,W 00--0---	UART2
000074H	UTIM[R]H(UTIMR[W]H) 00000000_00000000		DRCL[W]B -----	UTIMC[R/W]B 0--00001	U-TIMER/ UART2
000078H	ADCS2[R/W]B,H,W X000XX00	ADCS1[R/W]B,H,W 000X0000	ADCT[R/W]H,W XXXXXXXXX_XXXXXXXX		A/D converter successive approxima- tions
00007CH	ADTH0[R]B,H,W XXXXXXXXX	ADTL0[R]B,H,W 000000XX	ADTH1[R]B,H,W XXXXXXXXX	ADTL1[R]B,H,W 000000XX	
000080H	ADTH2[R]B,H,W XXXXXXXXX	ADTL2[R]B,H,W 000000XX	ADTH3[R]B,H,W XXXXXXXXX	ADTL3[R]B,H,W 000000XX	
000084H	_____	DACR2 [R/W]B,H,W*3 -----0	DACR1[R/W]B,H,W -----0	DACR0[R/W]B,H,W -----0	D/A converter*3
000088H	_____	DADR2 [R/W]B,H,W*3 XXXXXXXXX	DADR1[R/W]B,H,W XXXXXXXXX	DADR0[R/W]B,H,W XXXXXXXXX	
00008CH	_____	_____	_____	_____	Reserved
000090H	_____	_____	_____	_____ *1	Reserved
000094H	IBCR[R/W]B,H,W 00000000	IBSR[R]B,H,W 00000000	ITBA[R/W]B,H,W -----00_00000000		I <sup>2</sup> C interface
000098H	ITMK[R/W]B,H,W 00----11_11111111		ISMK[R/W]B,H,W 01111111	ISBA[R/W]B,H,W -0000000	
00009CH	_____ *2	IDAR[R/W]B,H,W 00000000	ICCR[R/W]B,H,W 0-011111	IDBL[R/W]B,H,W -----0	

(Continued)

# MB91350A Series

Address	Register				Block
	+0	+1	+2	+3	
0000A0 <sub>H</sub>	_____	_____ *1	_____	_____ *1	Reserved
0000A4 <sub>H</sub>	_____	_____ *1	_____ *1	_____ *1	
0000A8 <sub>H</sub>	TMRLR[R/W]H,W XXXXXXXXXX_XXXXXXXXXX		TMR[R]H,W XXXXXXXXXX_XXXXXXXXXX		Reload timer 3
0000AC <sub>H</sub>	_____		TMCSR[R/W]B,H,W ----0000_00000000		
0000B0 <sub>H</sub>	RCR1[R/W]B,H,W*3 00000000	RCR0[R/W]B,H,W 00000000	UDCR1[R]B,H,W*3 00000000	UDCR0[R]B,H,W 00000000	8/16-bit Up/Down counter 0, 1*3
0000B4 <sub>H</sub>	CCRH0[R/W]B,H,W 00000000	CCRL0[R/W]B,H,W 00001000	_____	CSR0[R/W]B,H,W 00000000	
0000B8 <sub>H</sub>	CCRH1[R/W]B,H,W*3 00000000	CCRL1[R/W]B,H,W*3 00001000	_____	CSR1[R/W]B,H,W*3 00000000	
0000BC <sub>H</sub>	_____	_____	_____	_____	Reserved
0000C0 <sub>H</sub>	SSR[R/W]B,H,W 00001000	SIDR[R/W]B,H,W XXXXXXXXXX	SCR[R/W]B,H,W 00000100	SMR[R/W]B,H,W 00--0---	UART3
0000C4 <sub>H</sub>	UTIM[R]H(UTIMR[W]H) 00000000_00000000		_____	UTIMC[R/W]B 0--00001	U-TIMER/ UART3
0000C8 <sub>H</sub>	SSR[R/W]B,H,W*3 00001000	SIDR[R/W]B,H,W*3 XXXXXXXXXX	SCR[R/W]B,H,W*3 00000100	SMR[R/W]B,H,W*3 00--0---	UART4*3
0000CC <sub>H</sub>	UTIM[R]H(UTIMR[W]H)*3 00000000_00000000		_____	UTIMC[R/W]B*3 0--00001	U-TIMER/ UART4*3
0000D0 <sub>H</sub>	EIRR1[R/W]B,H,W*3 00000000	ENIR1[R/W]B,H,W*3 00000000	ELVR1[R/W]B,H,W*3 00000000		External interrupts (INT8 to INT15)*3
0000D4 <sub>H</sub>	TCDT[R/W]H,W 00000000_00000000		_____	TCCS[R/W]B,H,W 00000000	16-bit free-run timer
0000D8 <sub>H</sub>	IPCP1[R]H,W XXXXXXXXXX_XXXXXXXXXX		IPCP0[R]H,W XXXXXXXXXX_XXXXXXXXXX		16-bit input capture
0000DC <sub>H</sub>	IPCP3[R]H,W XXXXXXXXXX_XXXXXXXXXX		IPCP2[R]H,W XXXXXXXXXX_XXXXXXXXXX		
0000E0 <sub>H</sub>	_____	ICS23[R/W]B,H,W 00000000	_____	ICS01[R/W]B,H,W 00000000	

(Continued)

# MB91350A Series

Address	Register				Block
	+0	+1	+2	+3	
0000E4 <sub>H</sub>	OCCP1[R/W]H,W*3 XXXXXXXXX_XXXXXXXXX		OCCP0[R/W]H,W XXXXXXXXX_XXXXXXXXX		16-bit output compare*3
0000E8 <sub>H</sub>	OCCP3[R/W]H,W*3 XXXXXXXXX_XXXXXXXXX		OCCP2[R/W]H,W XXXXXXXXX_XXXXXXXXX		
0000EC <sub>H</sub>	OCCP5[R/W]H,W*3 XXXXXXXXX_XXXXXXXXX		OCCP4[R/W]H,W*3 XXXXXXXXX_XXXXXXXXX		
0000F0 <sub>H</sub>	OCCP7[R/W]H,W*3 XXXXXXXXX_XXXXXXXXX		OCCP6[R/W]H,W*3 XXXXXXXXX_XXXXXXXXX		
0000F4 <sub>H</sub>	OCS23[R/W]B,H,W 11101100_00001100		OCS01[R/W]B,H,W 11101100_00001100		
0000F8 <sub>H</sub>	OCS67[R/W]B,H,W*3 11101100_00001100		OCS45[R/W]B,H,W*3 11101100_00001100		
0000FC <sub>H</sub>	_____	_____	_____	_____	Reserved
000100 <sub>H</sub> to 000114 <sub>H</sub>	_____	_____	_____	_____	Reserved
000118 <sub>H</sub>	GCN10[R/W]H 00110010_00010000		_____	GCN20[R/W]B 00000000	PPG control 0
00011C <sub>H</sub>	_____		_____		Reserved
000120 <sub>H</sub>	PTMR0[R]H,W 11111111_11111111		PCSR0[W]H,W XXXXXXXXX_XXXXXXXXX		PPG0
000124 <sub>H</sub>	PDUT0[W]H,W XXXXXXXXX_XXXXXXXXX		PCNH0[R/W]B,H,W 00000000	PCNL0[R/W]B,H,W 00000000	
000128 <sub>H</sub>	PTMR1[R]H,W*3 11111111_11111111		PCSR1[W]H,W*3 XXXXXXXXX_XXXXXXXXX		PPG1*3
00012C <sub>H</sub>	PDUT1[W]H,W*3 XXXXXXXXX_XXXXXXXXX		PCNH1[R/W]B,H,W*3 00000000	PCNL1[R/W]B,H,W*3 00000000	
000130 <sub>H</sub>	PTMR2[R]H,W 11111111_11111111		PCSR2[W]H,W XXXXXXXXX_XXXXXXXXX		PPG2
000134 <sub>H</sub>	PDUT2[W]H,W XXXXXXXXX_XXXXXXXXX		PCNH2[R/W]B,H,W 00000000	PCNL2[R/W]B,H,W 00000000	
000138 <sub>H</sub>	PTMR3[R]H,W*3 11111111_11111111		PCSR3[W]H,W*3 XXXXXXXXX_XXXXXXXXX		PPG3*3
00013C <sub>H</sub>	PDUT3[W]H,W*3 XXXXXXXXX_XXXXXXXXX		PCNH3[R/W]B,H,W*3 00000000	PCNL3[R/W]B,H,W*3 00000000	
000140 <sub>H</sub>	PTMR4[R]H,W 11111111_11111111		PCSR4[W]H,W XXXXXXXXX_XXXXXXXXX		PPG4
000144 <sub>H</sub>	PDUT4[W]H,W XXXXXXXXX_XXXXXXXXX		PCNH4[R/W]B,H,W 00000000	PCNL4[R/W]B,H,W 00000000	

(Continued)

# MB91350A Series

Address	Register				Block
	+0	+1	+2	+3	
000148H	PTMR5[R]H,W*3 11111111_11111111		PCSR5[W]H,W*3 XXXXXXXX_XXXXXXXX		PPG5*3
00014CH	PDUT5[W]H,W*3 XXXXXXXX_XXXXXXXX		PCNH5[R/W]B,H,W*3 00000000	PCNL5[R/W]B,H,W*3 00000000	
000150H to 0001FCH	_____				Reserved
000200H	DMACA0[R/W]B,H,W *4 00000000_0000XXXX_XXXXXXXX_XXXXXXXX				DMAC
000204H	DMACB0[R/W]B,H,W 00000000_00000000_XXXXXXXX_XXXXXXXX				
000208H	DMACA1[R/W]B,H,W *4 00000000_0000XXXX_XXXXXXXX_XXXXXXXX				
00020CH	DMACB1[R/W]B,H,W 00000000_00000000_XXXXXXXX_XXXXXXXX				
000210H	DMACA2[R/W]B,H,W *4 00000000_0000XXXX_XXXXXXXX_XXXXXXXX				
000214H	DMACB2[R/W]B,H,W 00000000_00000000_XXXXXXXX_XXXXXXXX				
000218H	DMACA3[R/W]B,H,W *4 00000000_0000XXXX_XXXXXXXX_XXXXXXXX				
00021CH	DMACB3[R/W]B,H,W 00000000_00000000_XXXXXXXX_XXXXXXXX				
000220H	DMACA4[R/W]B,H,W *4 00000000_0000XXXX_XXXXXXXX_XXXXXXXX				
000224H	DMACB4[R/W]B,H,W 00000000_00000000_XXXXXXXX_XXXXXXXX				
000228H	_____				
00022CH to 00023CH	_____				
000240H	DMACR[R/W]B 0XX00000_XXXXXXXX_XXXXXXXX_XXXXXXXX				DMAC
000244H to 00027CH	_____				Reserved
000280H	FRLR[R/W]B,H,W*2 -----01	_____	_____	_____	Limit on F-bus RAM capacity

(Continued)

# MB91350A Series

Address	Register				Block
	+0	+1	+2	+3	
000284H to 00038CH	_____				Reserved
000390H	DRLR[R/W]B,H,W*2 -----01	_____	_____	_____	Limit on D-bus RAM capacity
000394H to 0003ECH	_____				Reserved
0003F0H	BSD0[W] XXXXXXXX_XXXXXXXX_XXXXXXXX_XXXXXXXX				Bit search module
0003F4H	BSD1[R/W] XXXXXXXX_XXXXXXXX_XXXXXXXX_XXXXXXXX				
0003F8H	BSDC[W] XXXXXXXX_XXXXXXXX_XXXXXXXX_XXXXXXXX				
0003FCH	BSRR[R] XXXXXXXX_XXXXXXXX_XXXXXXXX_XXXXXXXX				
000400H	DDRG[R/W]B*3 --000000	DDRH[R/W]B --000000	DDRI[R/W]B --000000	DDRJ[R/W]B*3 00000000	R-bus data direction register*3
000404H	DDRK[R/W]B 00000000	DDRL[R/W]B -----00	DDRM[R/W]B --000000	DDRN[R/W]B --000000	
000408H	DDRO[R/W]B 00000000	DDRP[R/W]B*3 ----0000	_____		
00040CH	_____				
000410H	PFRG[R/W]B*3 --00-00-	PFRH[R/W]B --00-00-	PFRI[R/W]B --00-00-	_____	R-bus port function register*3
000414H	_____	PFRL[R/W]B -----00	PFRM[R/W]B --00-00-	PFRN[R/W]B --000000	
000418H	PFRO[R/W]B 00000000	PFRP[R/W]B*3 ----0000	_____		
00041CH	_____				Reserved
000420H	PCRG[R/W]B*3 --000000	PCRH[R/W]B --000000	PCRI[R/W]B --000000	_____	R-bus pull-up control register*3
000424H	_____	_____	PCRM[R/W]B --000000	PCRN[R/W]B --000000	
000428H	PCRO[R/W]B 00000000	PCRP[R/W]B*3 ----0000	_____	_____	
00042CH to 00043CH	_____				Reserved

(Continued)

# MB91350A Series

Address	Register				Block
	+0	+1	+2	+3	
000440 <sub>H</sub>	ICR00[R/W]B,H,W ---11111	ICR01[R/W]B,H,W ---11111	ICR02[R/W]B,H,W ---11111	ICR03[R/W]B,H,W ---11111	Interrupt controller unit
000444 <sub>H</sub>	ICR04[R/W]B,H,W ---11111	ICR05[R/W]B,H,W ---11111	ICR06[R/W]B,H,W ---11111	ICR07[R/W]B,H,W ---11111	
000448 <sub>H</sub>	ICR08[R/W]B,H,W ---11111	ICR09[R/W]B,H,W ---11111	ICR10[R/W]B,H,W ---11111	ICR11[R/W]B,H,W ---11111	
00044C <sub>H</sub>	ICR12[R/W]B,H,W ---11111	ICR13[R/W]B,H,W ---11111	ICR14[R/W]B,H,W ---11111	ICR15[R/W]B,H,W ---11111	
000450 <sub>H</sub>	ICR16[R/W]B,H,W ---11111	ICR17[R/W]B,H,W ---11111	ICR18[R/W]B,H,W ---11111	ICR19[R/W]B,H,W ---11111	
000454 <sub>H</sub>	ICR20[R/W]B,H,W ---11111	ICR21[R/W]B,H,W ---11111	ICR22[R/W]B,H,W ---11111	ICR23[R/W]B,H,W ---11111	
000458 <sub>H</sub>	ICR24[R/W]B,H,W ---11111	ICR25[R/W]B,H,W ---11111	ICR26[R/W]B,H,W ---11111	ICR27[R/W]B,H,W ---11111	
00045C <sub>H</sub>	ICR28[R/W]B,H,W ---11111	ICR29[R/W]B,H,W ---11111	ICR30[R/W]B,H,W ---11111	ICR31[R/W]B,H,W ---11111	
000460 <sub>H</sub>	ICR32[R/W]B,H,W ---11111	ICR33[R/W]B,H,W ---11111	ICR34[R/W]B,H,W ---11111	ICR35[R/W]B,H,W ---11111	
000464 <sub>H</sub>	ICR36[R/W]B,H,W ---11111	ICR37[R/W]B,H,W ---11111	ICR38[R/W]B,H,W ---11111	ICR39[R/W]B,H,W ---11111	
000468 <sub>H</sub>	ICR40[R/W]B,H,W ---11111	ICR41[R/W]B,H,W ---11111	ICR42[R/W]B,H,W ---11111	ICR43[R/W]B,H,W ---11111	
00046C <sub>H</sub>	ICR44[R/W]B,H,W ---11111	ICR45[R/W]B,H,W ---11111	ICR46[R/W]B,H,W ---11111	ICR47[R/W]B,H,W ---11111	
000470 <sub>H</sub> to 00047C <sub>H</sub>	-----				
000480 <sub>H</sub>	RSRR[R/W]B,H,W 10000000	STCR[R/W]B,H,W 00110011	TBCR[R/W]B,H,W 00XXXX00	CTBR[W]B,H,W XXXXXXXXXX	
000484 <sub>H</sub>	CLKR[R/W]B,H,W 00000000	WPR[W]B,H,W XXXXXXXXXX	DIVR0[R/W]B,H,W 00000011	DIVR1[R/W]B,H,W 00000000	
000488 <sub>H</sub>	-----		OSCCR[R/W]B XXXXXXXXX0	-----	
00048C <sub>H</sub>	WPCR[R/W]B 00---000	-----	-----	-----	Watch timer
000490 <sub>H</sub>	OSCR[R/W]B 00---000	-----	-----	-----	Main clock oscillation stabilization wait timer
000494 <sub>H</sub>	RSTOP0[W]B 00000000	RSTOP1[W]B 00000000	RSTOP2[W]B 00000000	RSTOP3[W]B ----000	Peripheral stop control

(Continued)

# MB91350A Series

Address	Register				Block
	+0	+1	+2	+3	
000498 <sub>H</sub>	_____	_____	_____	_____	Reserved
00049C <sub>H</sub> to 0005FC <sub>H</sub>	_____				Reserved
000600 <sub>H</sub>	_____	_____	DDR2[R/W]B 00000000	DDR3[R/W]B 00000000	T-unit data direction register* <sup>3</sup>
000604 <sub>H</sub>	DDR4[R/W]B 00000000	DDR5[R/W]B 00000000	DDR6[R/W]B 00000000	_____	
000608 <sub>H</sub>	DDR8[R/W]B --000000	DDR9[R/W]B ---00000	DDRA[R/W]B ----0000	DDRB[R/W]B* <sup>3</sup> 00000000	
00060C <sub>H</sub>	DDRC[R/W]B* <sup>3</sup> -----000	_____			
000610 <sub>H</sub>	_____	_____	_____	_____	T-unit port function register* <sup>3</sup>
000614 <sub>H</sub>	_____	_____	PFR6[R/W]B 11111111	_____	
000618 <sub>H</sub>	PFR8[R/W]B --1--0--	PFR9[R/W]B ---010-1	PFRA[R/W]B ----1111	PFRB1[R/W]B* <sup>3</sup> 00000000	
00061C <sub>H</sub>	PFRB2[R/W]B* <sup>3</sup> 00----00	PFRC[R/W]B* <sup>3</sup> ---00000	_____	_____	
000620 <sub>H</sub>	_____	_____	PCR2[R/W]B 00000000	PCR3[R/W]B 00000000	T-unit pull-up control register* <sup>3</sup>
000624 <sub>H</sub>	PCR4[R/W]B 00000000	PCR5[R/W]B 00000000	PCR6[R/W]B 00000000	_____	
000628 <sub>H</sub>	PCR8[R/W]B --000000	PCR9[R/W]B 00000000	PCRA[R/W]B 00000000	PCRB[R/W]B* <sup>3</sup> 00000000	
00062C <sub>H</sub>	PCRC[R/W]B* <sup>3</sup> -----000	_____	_____	_____	
000630 <sub>H</sub> to 00063C <sub>H</sub>	_____				Reserved

(Continued)

# MB91350A Series

Address	Register				Block
	+0	+1	+2	+3	
000640 <sub>H</sub>	ASR0[R/W]H,W 00000000_00000000		ACR0[R/W]B,H,W 1111XX00_00000000		T-unit
000644 <sub>H</sub>	ASR1[R/W]H,W 00000000_00000000		ACR1[R/W]B,H,W XXXXXXXX_XXXXXXXX		
000648 <sub>H</sub>	ASR2[R/W]H,W 00000000_00000000		ACR2[R/W]B,H,W XXXXXXXX_XXXXXXXX		
00064C <sub>H</sub>	ASR3[R/W]H,W 00000000_00000000		ACR3[R/W]B,H,W XXXXXXXX_XXXXXXXX		
000650 <sub>H</sub>	ASR4[R/W]H,W 00000000_00000000		ACR4[R/W]B,H,W XXXXXXXX_XXXXXXXX		
000654 <sub>H</sub>	ASR5[R/W]H,W 00000000_00000000		ACR5[R/W]B,H,W XXXXXXXX_XXXXXXXX		
000658 <sub>H</sub>	ASR6[R/W]H,W 00000000_00000000		ACR6[R/W]B,H,W XXXXXXXX_XXXXXXXX		
00065C <sub>H</sub>	ASR7[R/W]H,W 00000000_00000000		ACR7[R/W]B,H,W XXXXXXXX_XXXXXXXX		
000660 <sub>H</sub>	AWR0[R/W]B,H,W 01111111_11111111		AWR1[R/W]B,H,W XXXXXXXX_XXXXXXXX		
000664 <sub>H</sub>	AWR2[R/W]B,H,W XXXXXXXX_XXXXXXXX		AWR3[R/W]B,H,W XXXXXXXX_XXXXXXXX		
000668 <sub>H</sub>	AWR4[R/W]B,H,W XXXXXXXX_XXXXXXXX		AWR5[R/W]B,H,W XXXXXXXX_XXXXXXXX		
00066C <sub>H</sub>	AWR6[R/W]B,H,W XXXXXXXX_XXXXXXXX		AWR7[R/W]B,H,W XXXXXXXX_XXXXXXXX		
000670 <sub>H</sub>	_____				
000674 <sub>H</sub>	_____				
000678 <sub>H</sub>	IOWR0[R/W]B,H,W XXXXXXXX	IOWR1[R/W]B,H,W XXXXXXXX	IOWR2[R/W]B,H,W XXXXXXXX	_____	
00067C <sub>H</sub>	_____				
000680 <sub>H</sub>	CSER[R/W]B,H,W 00000001	_____	_____	TCR[W]B,H,W 0000XXXX	
000684 <sub>H</sub> to 0007F8 <sub>H</sub>	_____				Reserved
0007FC <sub>H</sub>	_____	MODR[W] *5 XXXXXXXX	_____	_____	Mode register
000800 <sub>H</sub> to 000AFC <sub>H</sub>	_____				Reserved

(Continued)

# MB91350A Series

Address	Register				Block
	+0	+1	+2	+3	
000B00H	ESTS0[R/W] X0000000	ESTS1[R/W] XXXXXXXX	ESTS2[R] 1XXXXXXXX	_____	DSU (EVA chip only)
000B04H	ECTL0[R/W] 0X000000	ECTL1[R/W] 00000000	ECTL2[W] 000X0000	ECTL3[R/W] 00X00X11	
000B08H	ECNT0[W] XXXXXXXX	ECNT1[W] XXXXXXXX	EUSA[W] XXX00000	EDTC[W] 0000XXXX	
000B0CH	EWPT[R] 00000000_00000000		_____		
000B10H	EDTR0[W] XXXXXXXXXX_XXXXXXXXXX		EDTR1[W] XXXXXXXXXX_XXXXXXXXXX		
000B14H to 000B1CH	_____				
000B20H	EIA0[W] XXXXXXXXXX_XXXXXXXXXX_XXXXXXXXXX_XXXXXXXXXX				
000B24H	EIA1[W] XXXXXXXXXX_XXXXXXXXXX_XXXXXXXXXX_XXXXXXXXXX				
000B28H	EIA2[W] XXXXXXXXXX_XXXXXXXXXX_XXXXXXXXXX_XXXXXXXXXX				
000B2CH	EIA3[W] XXXXXXXXXX_XXXXXXXXXX_XXXXXXXXXX_XXXXXXXXXX				
000B30H	EIA4[W] XXXXXXXXXX_XXXXXXXXXX_XXXXXXXXXX_XXXXXXXXXX				
000B34H	EIA5[W] XXXXXXXXXX_XXXXXXXXXX_XXXXXXXXXX_XXXXXXXXXX				
000B38H	EIA6[W] XXXXXXXXXX_XXXXXXXXXX_XXXXXXXXXX_XXXXXXXXXX				
000B3CH	EIA7[W] XXXXXXXXXX_XXXXXXXXXX_XXXXXXXXXX_XXXXXXXXXX				
000B40H	EDTA[R/W] XXXXXXXXXX_XXXXXXXXXX_XXXXXXXXXX_XXXXXXXXXX				
000B44H	EDTM[R/W] XXXXXXXXXX_XXXXXXXXXX_XXXXXXXXXX_XXXXXXXXXX				
000B48H	EOA0[W] XXXXXXXXXX_XXXXXXXXXX_XXXXXXXXXX_XXXXXXXXXX				
000B4CH	EOA1[W] XXXXXXXXXX_XXXXXXXXXX_XXXXXXXXXX_XXXXXXXXXX				
000B50H	EPCR[R/W] XXXXXXXXXX_XXXXXXXXXX_XXXXXXXXXX_XXXXXXXXXX				

(Continued)

# MB91350A Series

Address	Register				Block
	+0	+1	+2	+3	
000B54H	EPSR[R/W] XXXXXXXXX_XXXXXXXXX_XXXXXXXXX_XXXXXXXXX				DSU (EVA chip only)
000B58H	EIAM0[W] XXXXXXXXX_XXXXXXXXX_XXXXXXXXX_XXXXXXXXX				
000B5CH	EIAM1[W] XXXXXXXXX_XXXXXXXXX_XXXXXXXXX_XXXXXXXXX				
000B60H	EOAM0/EODM0[W] XXXXXXXXX_XXXXXXXXX_XXXXXXXXX_XXXXXXXXX				
000B64H	EOAM1/EODM1[W] XXXXXXXXX_XXXXXXXXX_XXXXXXXXX_XXXXXXXXX				
000B68H	EOD0[W] XXXXXXXXX_XXXXXXXXX_XXXXXXXXX_XXXXXXXXX				
000B6CH	EOD1[W] XXXXXXXXX_XXXXXXXXX_XXXXXXXXX_XXXXXXXXX				
000B70H to 000BFC <sub>H</sub>	—————				Reserved
000C00H	Test register (access is not allowed.)				Interrupt controller unit
000C04H to 000C14 <sub>H</sub>	Test register (access is not allowed.)				R-bus test
000C18H to 000FFC <sub>H</sub>	—————				Reserved
001000H	DMASA0[R/W]W XXXXXXXXX_XXXXXXXXX_XXXXXXXXX_XXXXXXXXX				DMAC
001004H	DMADA0[R/W]W XXXXXXXXX_XXXXXXXXX_XXXXXXXXX_XXXXXXXXX				
001008H	DMASA1[R/W]W XXXXXXXXX_XXXXXXXXX_XXXXXXXXX_XXXXXXXXX				
00100CH	DMADA1[R/W]W XXXXXXXXX_XXXXXXXXX_XXXXXXXXX_XXXXXXXXX				
001010H	DMASA2[R/W]W XXXXXXXXX_XXXXXXXXX_XXXXXXXXX_XXXXXXXXX				
001014H	DMADA2[R/W]W XXXXXXXXX_XXXXXXXXX_XXXXXXXXX_XXXXXXXXX				
001018H	DMASA3[R/W]W XXXXXXXXX_XXXXXXXXX_XXXXXXXXX_XXXXXXXXX				
00101CH	DMADA3[R/W]W XXXXXXXXX_XXXXXXXXX_XXXXXXXXX_XXXXXXXXX				

(Continued)

# MB91350A Series

(Continued)

Address	Register				Block
	+0	+1	+2	+3	
001020H	DMASA4[R/W]W XXXXXXXX_XXXXXXXX_XXXXXXXX_XXXXXXXX				DMAC
001024H	DMADA4[R/W]W XXXXXXXX_XXXXXXXX_XXXXXXXX_XXXXXXXX				
001028H to 001FFCH	_____				Reserved
007000H	FLCR[R/W] 0110X000	_____	_____	_____	Flash memory
007004H	FLWC[R/W] 00010011	_____	_____	_____	
007008H	_____	_____	_____	_____	
00700CH	_____	_____	_____	_____	
007010H	_____	_____	_____	_____	
007014H to 0070FFH	_____				Reserved

\*1 : This is a test register. Access is disabled.

\*2 : The available area of internal RAM is restricted immediately after a reset is released. This setting therefore needs to be changed before using the internal RAM.  
In addition, at least one NOP instruction is required immediately after overwriting the setting for the available RAM area.

\*3 : This register does not exist on the MB91F353A/353A/352A/351A. Access is disabled.

\*4 : The 16 low-order bits (DTC [15 : 0]) of DMACA0 to DMACA4 cannot be byte-accessed.

\*5 : This register is accessed by the mode vector fetch. It cannot be accessed during normal operation.

## 3. Vector table

Interrupt source	Interrupt number		Interrupt level	Offset	TBR default address	Resource number
	10	16				
Reset	0	00	—	3FC <sub>H</sub>	000FFFFC <sub>H</sub>	—
Mode vector	1	01	—	3F8 <sub>H</sub>	000FFFF8 <sub>H</sub>	—
System reserved	2	02	—	3F4 <sub>H</sub>	000FFFF4 <sub>H</sub>	—
System reserved	3	03	—	3F0 <sub>H</sub>	000FFFF0 <sub>H</sub>	—
System reserved	4	04	—	3EC <sub>H</sub>	000FFFE <sub>C</sub>	—
System reserved	5	05	—	3E8 <sub>H</sub>	000FFFE8 <sub>H</sub>	—
System reserved	6	06	—	3E4 <sub>H</sub>	000FFFE4 <sub>H</sub>	—
Coprocessor absent trap	7	07	—	3E0 <sub>H</sub>	000FFFE0 <sub>H</sub>	—
Coprocessor error trap	8	08	—	3DC <sub>H</sub>	000FFFD <sub>C</sub>	—
INTE instruction	9	09	—	3D8 <sub>H</sub>	000FFFD8 <sub>H</sub>	—
System reserved	10	0A	—	3D4 <sub>H</sub>	000FFFD4 <sub>H</sub>	—
System reserved	11	0B	—	3D0 <sub>H</sub>	000FFFD0 <sub>H</sub>	—
Step trace trap	12	0C	—	3CC <sub>H</sub>	000FFFC <sub>C</sub>	—
NMI request (tool)	13	0D	—	3C8 <sub>H</sub>	000FFFC8 <sub>H</sub>	—
Undefined instruction exception	14	0E	—	3C4 <sub>H</sub>	000FFFC4 <sub>H</sub>	—
NMI request	15	0F	15 (F <sub>H</sub> ) fixed	3C0 <sub>H</sub>	000FFFC0 <sub>H</sub>	—
External interrupt 0	16	10	ICR00	3BC <sub>H</sub>	000FFFB <sub>C</sub>	6
External interrupt 1	17	11	ICR01	3B8 <sub>H</sub>	000FFFB8 <sub>H</sub>	7
External interrupt 2	18	12	ICR02	3B4 <sub>H</sub>	000FFFB4 <sub>H</sub>	11
External interrupt 3	19	13	ICR03	3B0 <sub>H</sub>	000FFFB0 <sub>H</sub>	—
External interrupt 4	20	14	ICR04	3AC <sub>H</sub>	000FFFA <sub>C</sub>	—
External interrupt 5	21	15	ICR05	3A8 <sub>H</sub>	000FFFA8 <sub>H</sub>	—
External interrupt 6	22	16	ICR06	3A4 <sub>H</sub>	000FFFA4 <sub>H</sub>	—
External interrupt 7	23	17	ICR07	3A0 <sub>H</sub>	000FFFA0 <sub>H</sub>	—
Reload timer 0	24	18	ICR08	39C <sub>H</sub>	000FFF9 <sub>C</sub>	8
Reload timer 1	25	19	ICR09	398 <sub>H</sub>	000FFF98 <sub>H</sub>	9
Reload timer 2	26	1A	ICR10	394 <sub>H</sub>	000FFF94 <sub>H</sub>	10
UART0 (Reception completed)	27	1B	ICR11	390 <sub>H</sub>	000FFF90 <sub>H</sub>	0
UART1 (Reception completed)	28	1C	ICR12	38C <sub>H</sub>	000FFF8 <sub>C</sub>	1
UART2 (Reception completed)	29	1D	ICR13	388 <sub>H</sub>	000FFF88 <sub>H</sub>	2
UART0 (Transmission completed)	30	1E	ICR14	384 <sub>H</sub>	000FFF84 <sub>H</sub>	3
UART1 (Transmission completed)	31	1F	ICR15	380 <sub>H</sub>	000FFF80 <sub>H</sub>	4
UART2 (Transmission completed)	32	20	ICR16	37C <sub>H</sub>	000FFF7 <sub>C</sub>	5
DMAC0 (end, error)	33	21	ICR17	378 <sub>H</sub>	000FFF78 <sub>H</sub>	—
DMAC1 (end, error)	34	22	ICR18	374 <sub>H</sub>	000FFF74 <sub>H</sub>	—

(Continued)

# MB91350A Series

Interrupt source	Interrupt number		Interrupt level	Offset	TBR default address	Resource number
	10	16				
DMAC2 (end, error)	35	23	ICR19	370 <sub>H</sub>	000FFF70 <sub>H</sub>	—
DMAC3 (end, error)	36	24	ICR20	36C <sub>H</sub>	000FFF6C <sub>H</sub>	—
DMAC4 (end, error)	37	25	ICR21	368 <sub>H</sub>	000FFF68 <sub>H</sub>	—
A/D	38	26	ICR22	364 <sub>H</sub>	000FFF64 <sub>H</sub>	15
I <sup>2</sup> C	39	27	ICR23	360 <sub>H</sub>	000FFF60 <sub>H</sub>	—
System reserved	40	28	ICR24	35C <sub>H</sub>	000FFF5C <sub>H</sub>	—
System reserved	41	29	ICR25	358 <sub>H</sub>	000FFF58 <sub>H</sub>	12
SIO 6	42	2A	ICR26	354 <sub>H</sub>	000FFF54 <sub>H</sub>	13
SIO 7	43	2B	ICR27	350 <sub>H</sub>	000FFF50 <sub>H</sub>	14
UART3 (Reception completed)	44	2C	ICR28	34C <sub>H</sub>	000FFF4C <sub>H</sub>	—
UART3 (Transmission completed)	45	2D	ICR29	348 <sub>H</sub>	000FFF48 <sub>H</sub>	—
Reload timer 3/main oscillation stabilization wait timer	46	2E	ICR30	344 <sub>H</sub>	000FFF44 <sub>H</sub>	—
Timebase timer overflow	47	2F	ICR31	340 <sub>H</sub>	000FFF40 <sub>H</sub>	—
System reserved	48	30	ICR32	33C <sub>H</sub>	000FFF3C <sub>H</sub>	—
Watch counter	49	31	ICR33	338 <sub>H</sub>	000FFF38 <sub>H</sub>	—
U/D Counter 0	50	32	ICR34	334 <sub>H</sub>	000FFF34 <sub>H</sub>	—
System reserved	51	33	ICR35	330 <sub>H</sub>	000FFF30 <sub>H</sub>	—
PPG 0	52	34	ICR36	32C <sub>H</sub>	000FFF2C <sub>H</sub>	—
PPG 2	53	35	ICR37	328 <sub>H</sub>	000FFF28 <sub>H</sub>	—
PPG 4	54	36	ICR38	324 <sub>H</sub>	000FFF24 <sub>H</sub>	—
16-bit free-run timer	55	37	ICR39	320 <sub>H</sub>	000FFF20 <sub>H</sub>	—
ICU 0 (capture)	56	38	ICR40	31C <sub>H</sub>	000FFF1C <sub>H</sub>	—
ICU 1 (capture)	57	39	ICR41	318 <sub>H</sub>	000FFF18 <sub>H</sub>	—
ICU 2/3 (capture)	58	3A	ICR42	314 <sub>H</sub>	000FFF14 <sub>H</sub>	—
OCU 0 (match)	59	3B	ICR43	310 <sub>H</sub>	000FFF10 <sub>H</sub>	—
OCU 2 (match)	60	3C	ICR44	30C <sub>H</sub>	000FFF0C <sub>H</sub>	—
System reserved	61	3D	ICR45	308 <sub>H</sub>	000FFF08 <sub>H</sub>	—
System reserved	62	3E	ICR46	304 <sub>H</sub>	000FFF04 <sub>H</sub>	—
Interrupt delay source bit	63	3F	ICR47	300 <sub>H</sub>	000FFF00 <sub>H</sub>	—
System reserved (Used by REALOS)	64	40	—	2FC <sub>H</sub>	000FFEFC <sub>H</sub>	—
System reserved (Used by REALOS)	65	41	—	2F8 <sub>H</sub>	000FFEFC <sub>H</sub>	—
System reserved	66	42	—	2F4 <sub>H</sub>	000FFEFC <sub>H</sub>	—
System reserved	67	43	—	2F0 <sub>H</sub>	000FFEFC <sub>H</sub>	—
System reserved	68	44	—	2EC <sub>H</sub>	000FFEFC <sub>H</sub>	—

(Continued)

(Continued)

Interrupt source	Interrupt number		Interrupt level	Offset	TBR default address	Resource number
	10	16				
System reserved	69	45	—	2E8 <sub>H</sub>	000FFEE8 <sub>H</sub>	—
System reserved	70	46	—	2E4 <sub>H</sub>	000FFEE4 <sub>H</sub>	—
System reserved	71	47	—	2E0 <sub>H</sub>	000FFEE0 <sub>H</sub>	—
System reserved	72	48	—	2DC <sub>H</sub>	000FFEDC <sub>H</sub>	—
System reserved	73	49	—	2D8 <sub>H</sub>	000FFED8 <sub>H</sub>	—
System reserved	74	4A	—	2D4 <sub>H</sub>	000FFED4 <sub>H</sub>	—
System reserved	75	4B	—	2D0 <sub>H</sub>	000FFED0 <sub>H</sub>	—
System reserved	76	4C	—	2CC <sub>H</sub>	000FFECC <sub>H</sub>	—
System reserved	77	4D	—	2C8 <sub>H</sub>	000FFEC8 <sub>H</sub>	—
System reserved	78	4E	—	2C4 <sub>H</sub>	000FFEC4 <sub>H</sub>	—
System reserved	79	4F	—	2C0 <sub>H</sub>	000FFEC0 <sub>H</sub>	—
Used by INT instruction	80 to 255	50 to FF	—	2BC <sub>H</sub> to 000 <sub>H</sub>	000FFEBC <sub>H</sub> to 000FFC00 <sub>H</sub>	—

## ■ PERIPHERAL RESOURCES

### 1. Interrupt Controller

#### (1) Description

The interrupt controller manages interrupt reception and arbitration.

#### Hardware configuration

This module consists of the following components :

- ICR register
- Interrupt priority determination circuit
- Interrupt level and interrupt number (vector) generator
- HOLD request removal request generator

#### • Main functions

This module has the following major functions :

- Detect NMI and interrupt requests
- Prioritize interrupts (according to level and number)
- Notify interrupt level of selected interrupt request (to CPU)
- Notify interrupt number of selected interrupt request (to CPU)
- Request (to the CPU) to return from stop mode in response to an NMI or interrupt request with interrupt level other than "11111<sub>B</sub>"
- Issue requests to the bus master to cancel HOLD requests

## (2) Register list

### Interrupt Control Register (ICR)

	bit 7	bit 6	bit 5	bit 4	bit 3	bit 2	bit 1	bit 0
ICR00	—	—	—	ICR4	ICR3	ICR2	ICR1	ICR0
ICR01	—	—	—	ICR4	ICR3	ICR2	ICR1	ICR0
ICR02	—	—	—	ICR4	ICR3	ICR2	ICR1	ICR0
ICR03	—	—	—	ICR4	ICR3	ICR2	ICR1	ICR0
ICR04	—	—	—	ICR4	ICR3	ICR2	ICR1	ICR0
ICR05	—	—	—	ICR4	ICR3	ICR2	ICR1	ICR0
ICR06	—	—	—	ICR4	ICR3	ICR2	ICR1	ICR0
ICR07	—	—	—	ICR4	ICR3	ICR2	ICR1	ICR0
ICR08	—	—	—	ICR4	ICR3	ICR2	ICR1	ICR0
ICR09	—	—	—	ICR4	ICR3	ICR2	ICR1	ICR0
ICR10	—	—	—	ICR4	ICR3	ICR2	ICR1	ICR0
ICR11	—	—	—	ICR4	ICR3	ICR2	ICR1	ICR0
ICR12	—	—	—	ICR4	ICR3	ICR2	ICR1	ICR0
ICR13	—	—	—	ICR4	ICR3	ICR2	ICR1	ICR0
ICR14	—	—	—	ICR4	ICR3	ICR2	ICR1	ICR0
ICR15	—	—	—	ICR4	ICR3	ICR2	ICR1	ICR0
ICR16	—	—	—	ICR4	ICR3	ICR2	ICR1	ICR0
ICR17	—	—	—	ICR4	ICR3	ICR2	ICR1	ICR0
ICR18	—	—	—	ICR4	ICR3	ICR2	ICR1	ICR0
ICR19	—	—	—	ICR4	ICR3	ICR2	ICR1	ICR0
ICR20	—	—	—	ICR4	ICR3	ICR2	ICR1	ICR0
ICR21	—	—	—	ICR4	ICR3	ICR2	ICR1	ICR0
ICR22	—	—	—	ICR4	ICR3	ICR2	ICR1	ICR0
ICR23	—	—	—	ICR4	ICR3	ICR2	ICR1	ICR0
ICR24	—	—	—	ICR4	ICR3	ICR2	ICR1	ICR0
ICR25	—	—	—	ICR4	ICR3	ICR2	ICR1	ICR0
ICR26	—	—	—	ICR4	ICR3	ICR2	ICR1	ICR0
ICR27	—	—	—	ICR4	ICR3	ICR2	ICR1	ICR0
ICR28	—	—	—	ICR4	ICR3	ICR2	ICR1	ICR0
ICR29	—	—	—	ICR4	ICR3	ICR2	ICR1	ICR0
ICR30	—	—	—	ICR4	ICR3	ICR2	ICR1	ICR0
ICR31	—	—	—	ICR4	ICR3	ICR2	ICR1	ICR0

(Continued)

# MB91350A Series

(Continued)

	bit 7	bit 6	bit 5	bit 4	bit 3	bit 2	bit 1	bit 0
ICR32	—	—	—	ICR4	ICR3	ICR2	ICR1	ICR0
ICR33	—	—	—	ICR4	ICR3	ICR2	ICR1	ICR0
ICR34	—	—	—	ICR4	ICR3	ICR2	ICR1	ICR0
ICR35	—	—	—	ICR4	ICR3	ICR2	ICR1	ICR0
ICR36	—	—	—	ICR4	ICR3	ICR2	ICR1	ICR0
ICR37	—	—	—	ICR4	ICR3	ICR2	ICR1	ICR0
ICR38	—	—	—	ICR4	ICR3	ICR2	ICR1	ICR0
ICR39	—	—	—	ICR4	ICR3	ICR2	ICR1	ICR0
ICR40	—	—	—	ICR4	ICR3	ICR2	ICR1	ICR0
ICR41	—	—	—	ICR4	ICR3	ICR2	ICR1	ICR0
ICR42	—	—	—	ICR4	ICR3	ICR2	ICR1	ICR0
ICR43	—	—	—	ICR4	ICR3	ICR2	ICR1	ICR0
ICR44	—	—	—	ICR4	ICR3	ICR2	ICR1	ICR0
ICR45	—	—	—	ICR4	ICR3	ICR2	ICR1	ICR0
ICR46	—	—	—	ICR4	ICR3	ICR2	ICR1	ICR0
ICR47	—	—	—	ICR4	ICR3	ICR2	ICR1	ICR0

Hold request cancel request register (HRCL)

HRCL	MHALTI	—	—	LVL4	LVL3	LVL2	LVL1	LVL0
------	--------	---	---	------	------	------	------	------

(3) Block diagram

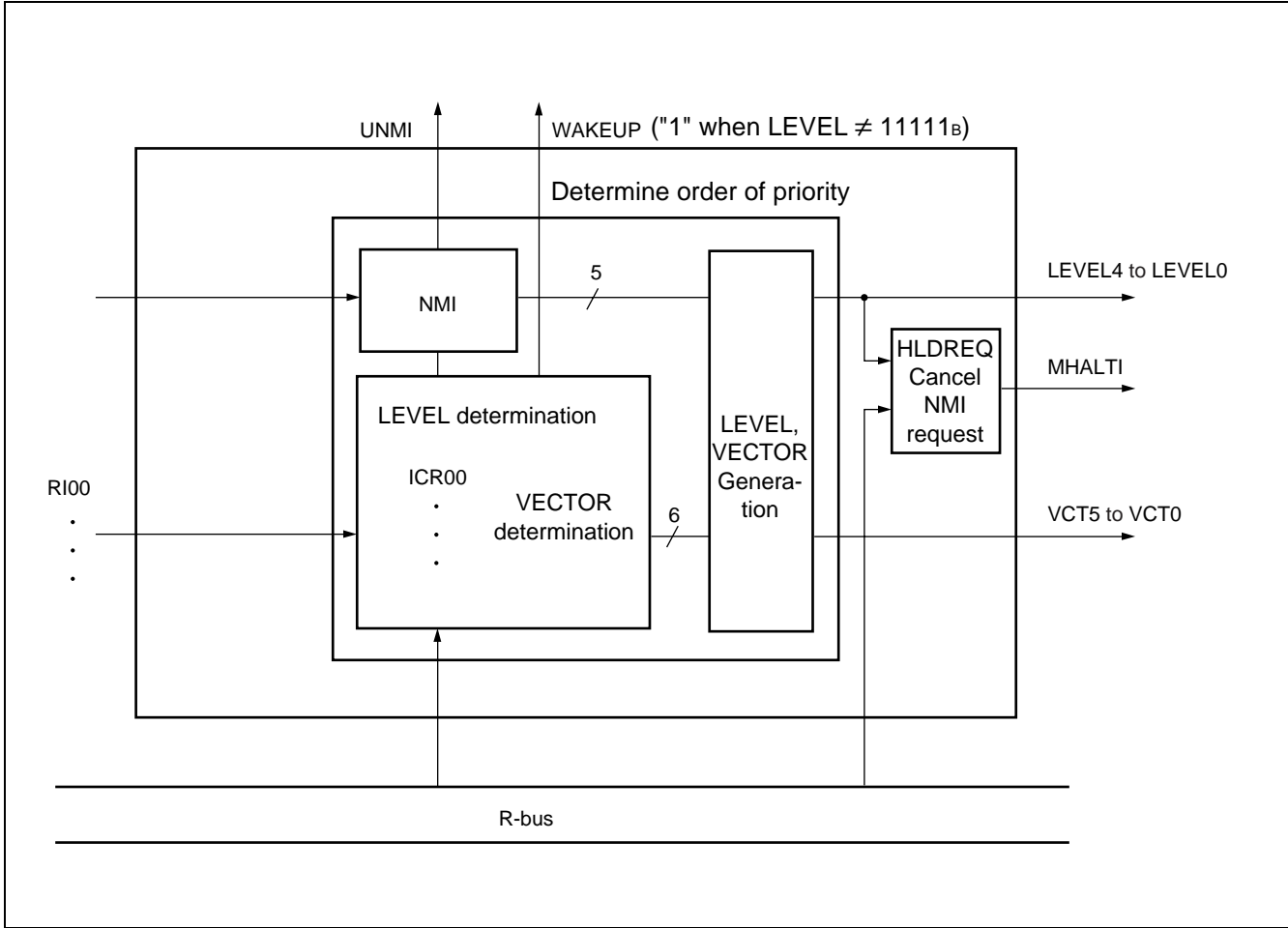

# MB91350A Series

## 2. External Interrupt/NMI Control

### (1) Description

The external interrupt control unit is the block that controls external interrupt requests input to  $\overline{\text{NMI}}$  and INTO to INT15. The level that is detected as a request can be selected from “H”, “L”, rising edge, or falling edge (except for NMI).

Note : The MB91F353A/353A/352A/351A does not have INT8 to INT15.

### (2) Register list

#### External interrupt enable register (ENIR)

bit 7	bit 6	bit 5	bit 4	bit 3	bit 2	bit 1	bit 0
EN7	EN6	EN5	EN4	EN3	EN2	EN1	EN0

#### External interrupt request register (EIRR)

bit 15	bit 14	bit 13	bit 12	bit 11	bit 10	bit 9	bit 8
ER7	ER6	ER5	ER4	ER3	ER2	ER1	ER0

#### Request level setting register (ELVR)

bit 15	bit 14	bit 13	bit 12	bit 11	bit 10	bit 9	bit 8
LB7	LA7	LB6	LA6	LB5	LA5	LB4	LA4
bit 7	bit 6	bit 5	bit 4	bit 3	bit 2	bit 1	bit 0
LB3	LA3	LB2	LA2	LB1	LA1	LB0	LA0

The above registers (for 8 channels) are available in 2 sets; there are a total of 16 channels.

### (3) Block diagram

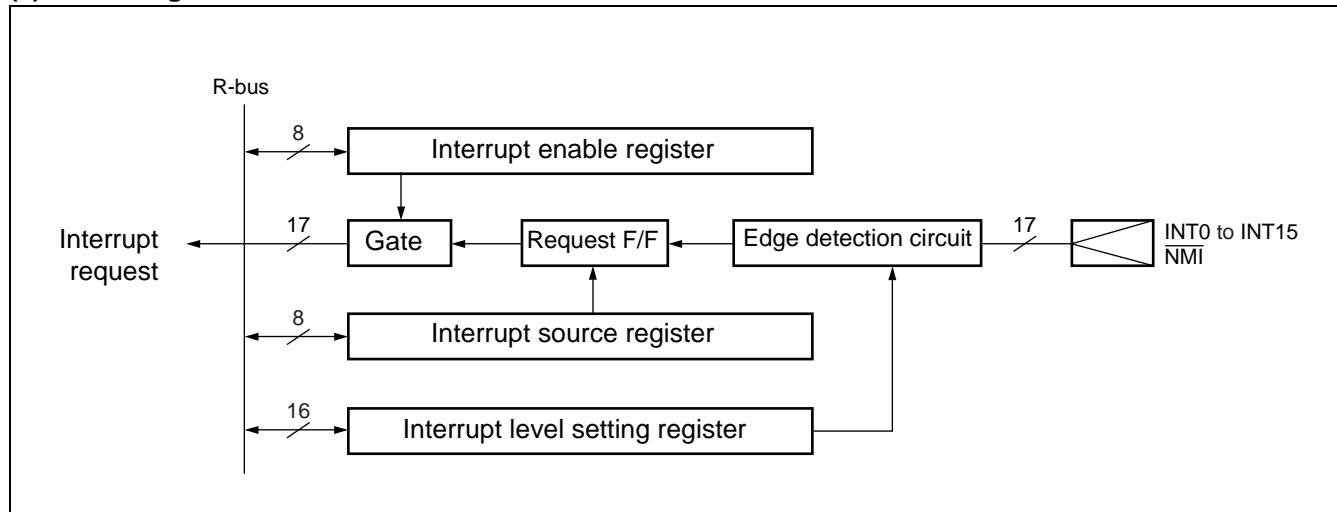

### 3. REALOS-related Hardware

REALOS-related hardware is used by the real-time OS. Therefore, it cannot be used by user programs when REALOS is used.

- Delay interrupt module

(1) Description

The delayed interrupt module generates a task switching interrupt. This module enables software to issue or cancel an interrupt request to the CPU.

(2) Register list

Delayed Interrupt Control Register (DICR)							
bit 7	bit 6	bit 5	bit 4	bit 3	bit 2	bit 1	bit 0
—	—	—	—	—	—	—	DLYI

(3) Block diagram

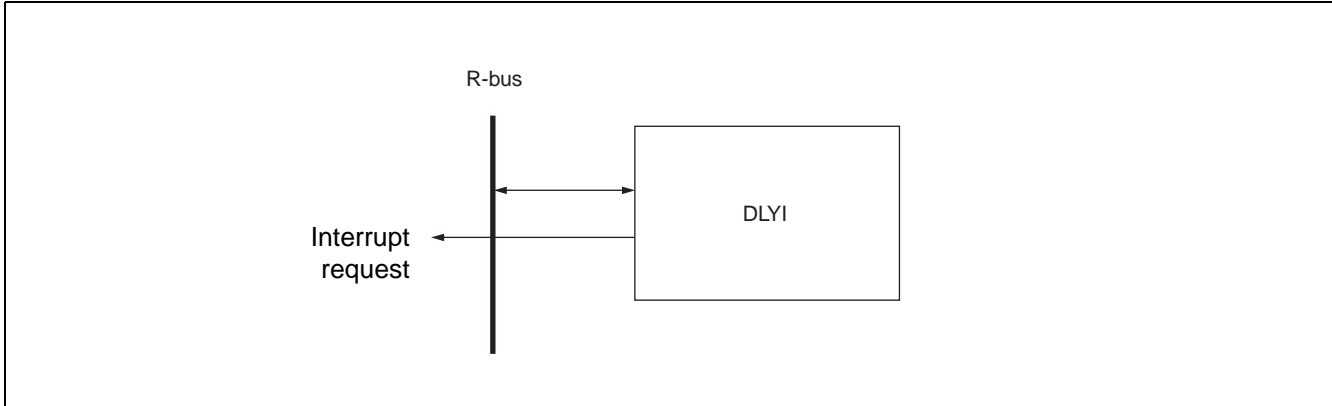

# MB91350A Series

## • Bit Search Module

### (1) Description

The bit search module searches data written to an input register for “0”, “1”, or a change point and returns the detected bit position.

### (2) Register list

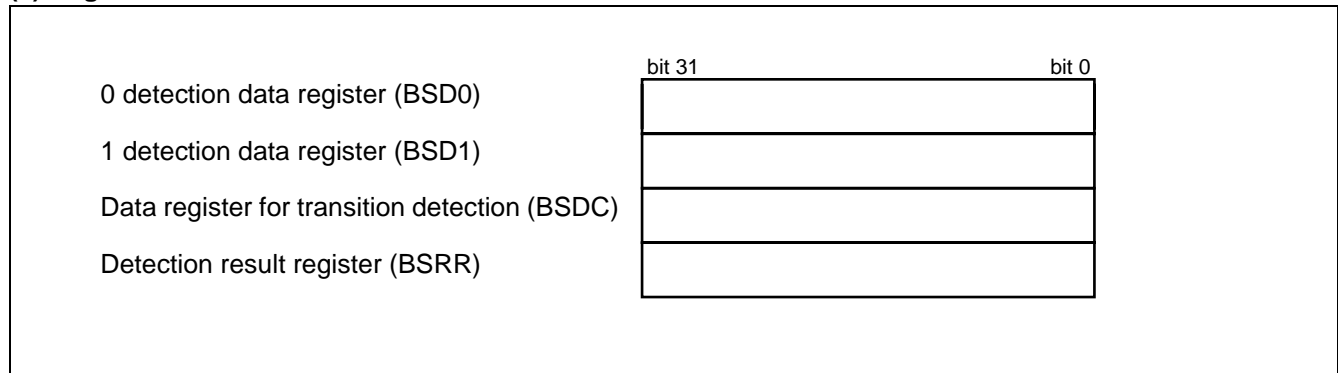

### (3) Block diagram

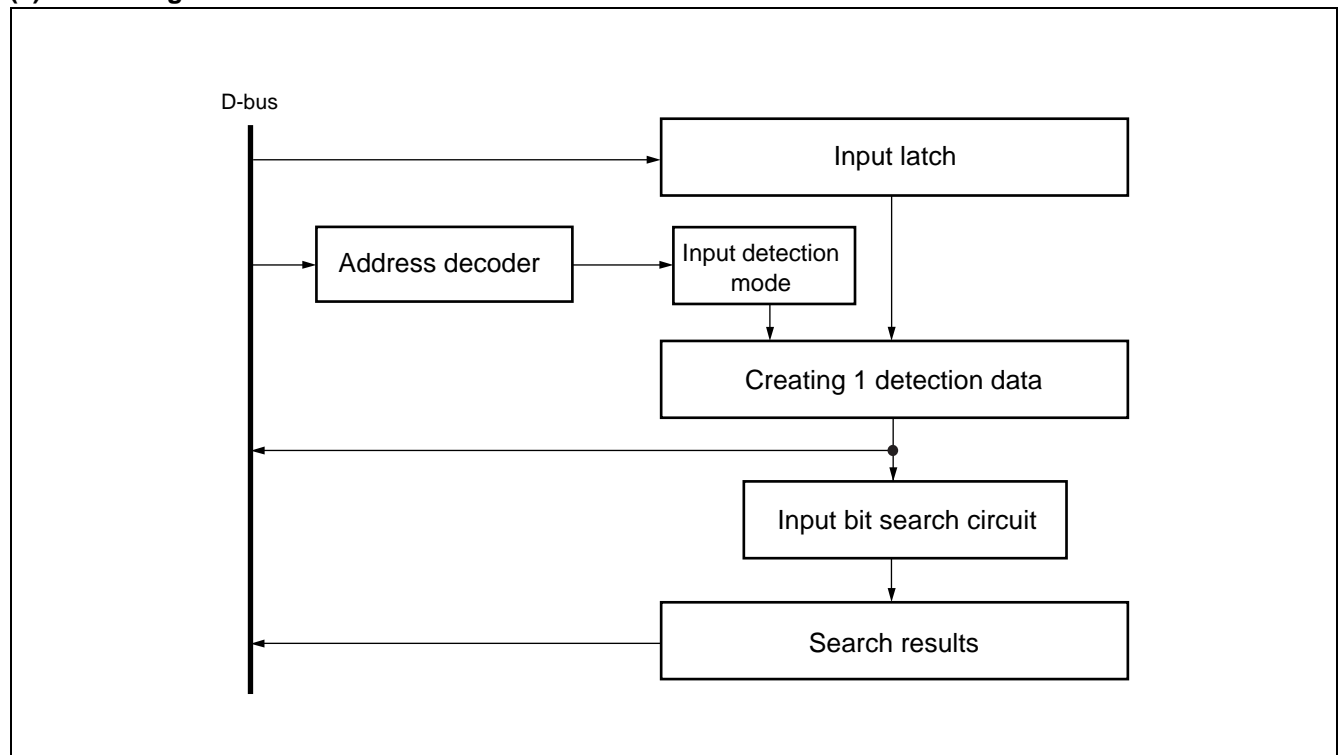

## 4. 8/16-bit Up/Down Counter

### (1) Description

This block is the up/down counter/timer consisting of six event input pins, two 8-bit up/down counter, two 8-bit reload/compare registers, and their control circuit.

The MB91F355A/F356B/F357B/355A/354A/V350A contains 2 channels of 8-bit up/down counter in this block.

The MB91F353A/353A/352A/351A contains 1 channel of 8-bit up/down counter in this block. It is not possible to use in 16-bit mode.

This module has the following features.

- 8-bit count register enabling counting from (0)d to (255)d (enabling counting from (0)d to (65535)d in 16 bits × 1 operation mode)
- Four different count modes available with selectable count clocks

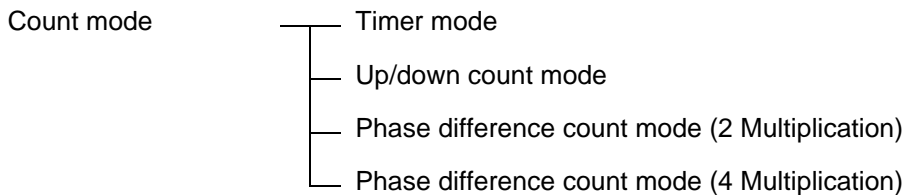

- In timer mode, the ability to select the count clock input to use from among two internal clock circuits

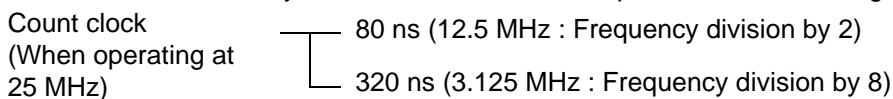

- In up/down count mode, the ability to select the edge detection of the external pin input signals

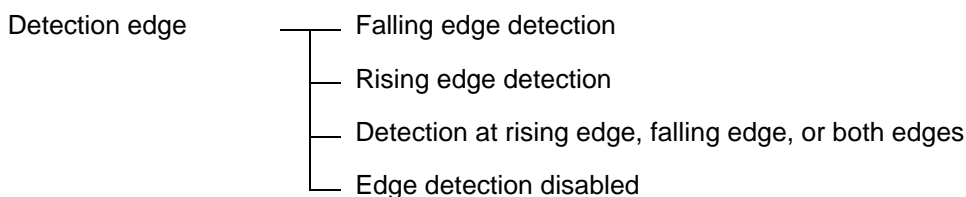

- The phase difference count mode is suitable for counting encoders such as motor encoders, and facilitates to count the angle of revolution and number of revolutions to a high precision by inputting the A phase, B phase, and Z phase outputs from the encoder

- ZIN pin has two selectable functions (valid in all modes)

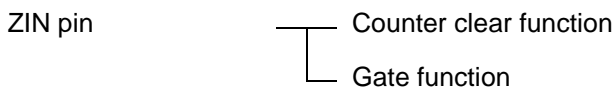

- Compare and reload functions that can be used separately or in combination. When both functions are used in combination, up/down counting can be performed at an arbitrary width.

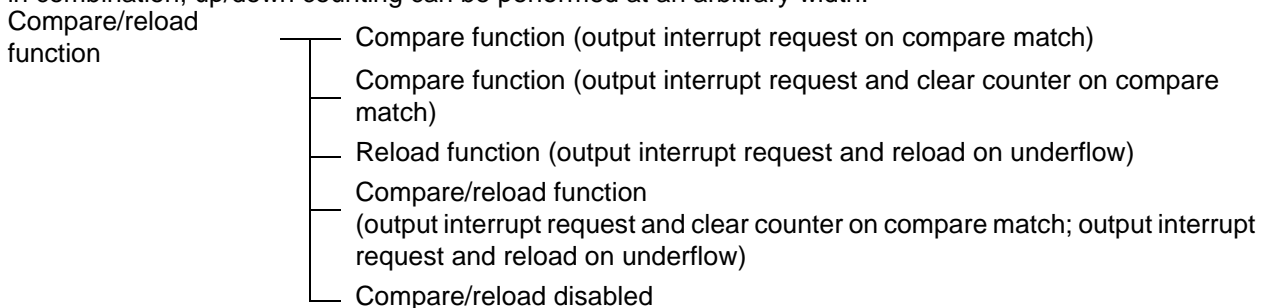

- Count direction flag used to identify the preceding count direction
- Capable of independently controlling the generation of interrupts for compare match, reload (underflow), overflow, or on count direction change

## (2) Register list

- **Up/down count register (UDCR)**

Up/down count register ch.0 (UDCR0)

bit 7	bit 6	bit 5	bit 4	bit 3	bit 2	bit 1	bit 0
D07	D06	D05	D04	D03	D02	D01	D00

Up/down count register ch.1 (UDCR1)\*

bit 15	bit 14	bit 13	bit 12	bit 11	bit 10	bit 9	bit 8
D15	D14	D13	D12	D11	D10	D09	D08

- **Reload compare register (RCR)**

Reload compare register ch.0 (RCR0)

bit 7	bit 6	bit 5	bit 4	bit 3	bit 2	bit 1	bit 0
D07	D06	D05	D04	D03	D02	D01	D00

Reload compare register ch.1 (RCR1)\*

bit 15	bit 14	bit 13	bit 12	bit 11	bit 10	bit 9	bit 8
D15	D14	D13	D12	D11	D10	D09	D08

- **Counter status register (CSR)**

Counter status register ch.0, ch.1 (CSR0, CSR1\*)

bit 7	bit 6	bit 5	bit 4	bit 3	bit 2	bit 1	bit 0
CSTR	CITE	UDIE	CMPF	OVFF	UDFF	UDF1	UDF0

- **Counter control register (CCRL)**

Counter control register ch.0, ch.1 (CCRL0, CCRL1\*)

bit 7	bit 6	bit 5	bit 4	bit 3	bit 2	bit 1	bit 0
Reserved	CTUT	UCRE	RLDE	UDCC	CGSC	CGE1	CGE0

- **Counter control register (CCRH)**

Counter control register ch.0 (CCRH0)

bit 15	bit 14	bit 13	bit 12	bit 11	bit 10	bit 9	bit 8
M16E	CDCF	CFIE	CLKS	CMS1	CMS0	CES1	CES0

- **Counter control register ch.1 (CCRH1)\***

bit 15	bit 14	bit 13	bit 12	bit 11	bit 10	bit 9	bit 8
Reserved	CDCF	CFIE	CLKS	CMS1	CMS0	CES1	CES0

\* : Access to the UDCR1, RCR1, CSR1, CCRL1, CCRH1 registers is prohibited on the MB91F353A/353A/352A/351A.

### (3) Block diagram

- 8/16-bit up/down counter (ch.0)

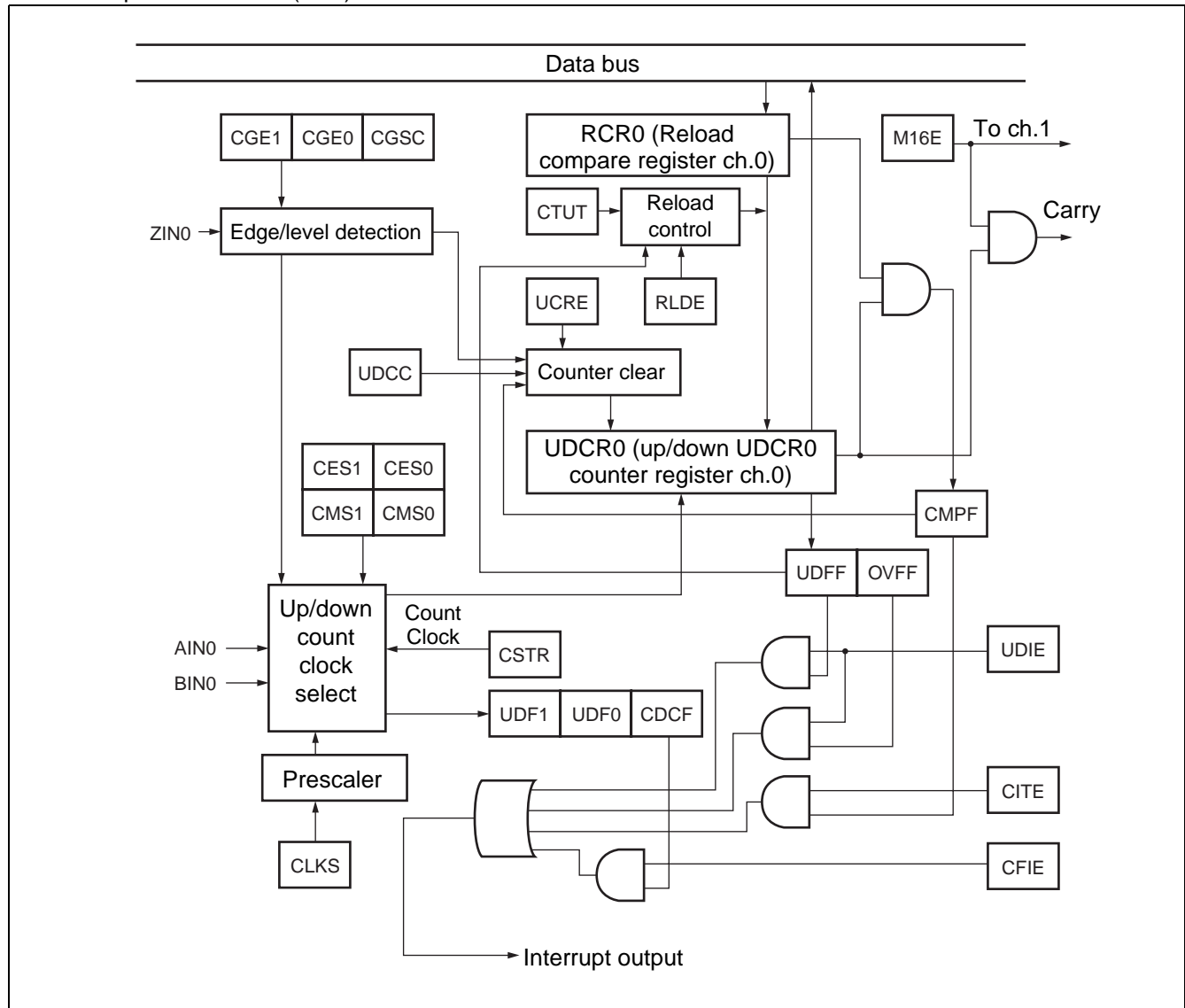

# MB91350A Series

## •8/16-bit up/down counter (ch.1)

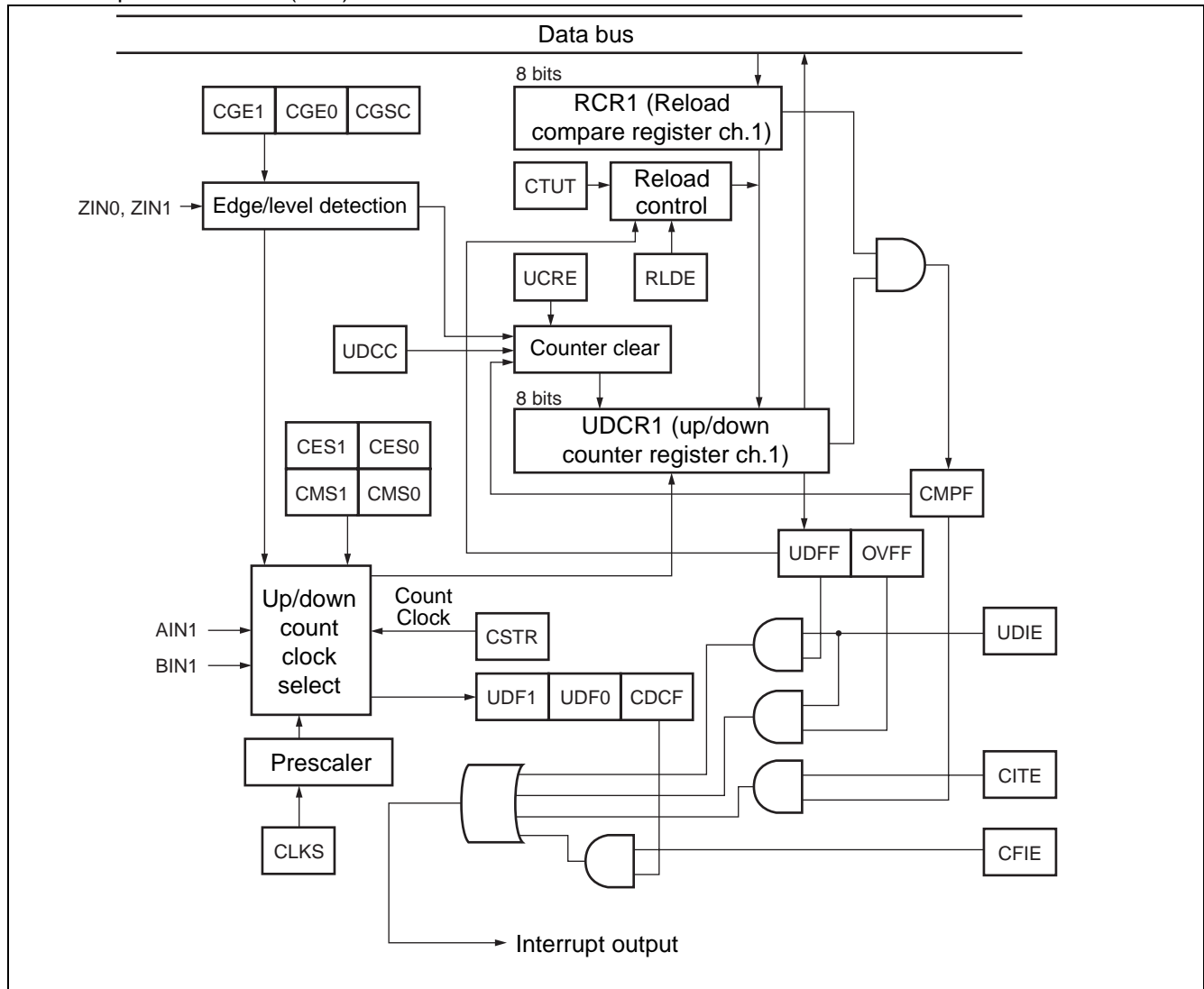

## 5. 16-bit Reload Timer

### (1) Description

The 16-bit timer consists of a 16-bit down counter, 16-bit reload register, internal clock, clock generation prescaler, and control register.

The clock source can be selected from among three internal clocks (prepared by frequency dividing the machine clock by 2/8/32, and also by 64/128 only for ch.3) and an external event.

The interrupt can be used to initiate a DMA transfer.

The MB91F353A/353A/352A/351A does not have timer outputs (TOT0 to TOT3).

This timer has 4 built-in channels.

### (2) Register list

Control status register (TMCSR)

bit 15	bit 14	bit 13	bit 12	bit 11	bit 10	bit 9	bit 8
—	—	Reserved	CSL2	CSL1	CSL0	Reserved	Reserved

(ch.3 only)

bit 7	bit 6	bit 5	bit 4	bit 3	bit 2	bit 1	bit 0
Reserved	—	OUTL	RELD	INTE	UF	CNTE	TRG

16-bit timer register (TMR)

bit 15																bit 0

16-bit reload register (TMRLR)

bit 15																bit 0

# MB91350A Series

## (3) Block diagram

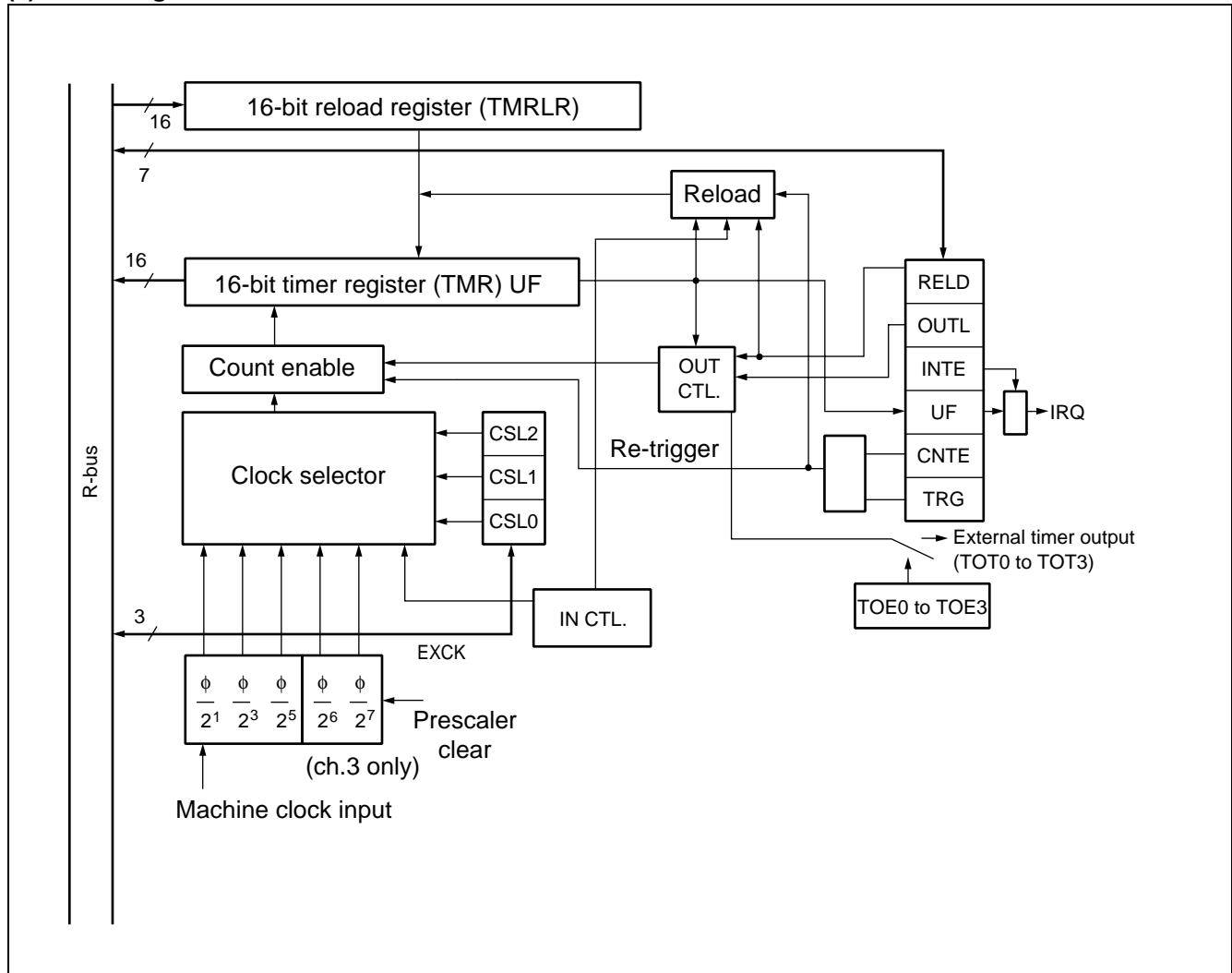

Note : The MB91F353A/353A/352A/351A does not have external timer outputs (TOT0 to TOT3).

## 6. PPG (Programmable Pulse Generator)

The PPG can efficiently output highly precise PWM wave forms.

The MB91F353A/353A/352A/351A contains 3 channels of PPG timer.

The MB91F355A/F356B/F357B/355A/354A/V350A contains 6 channels of PPG timer.

### (1) Description

Each channel consists of a 16-bit down counter, 16-bit data register with cycle setting buffer, 16-bit compare register with duty ratio setting buffer, and pin control unit.

The count clocks for the 16-bit down counter can be selected from the following 4 types : (peripheral clock  $\phi$ ,  $\phi/4$ ,  $\phi/16$ ,  $\phi/64$ )

The counter is initialized to "FFFF<sub>H</sub>" at a reset or counter borrow.

PPG outputs (PPG0 to PPG5) are provided for each channel.

Note : The MB91F353A/353A/352A/351A contains 3 channels of PPG outputs PPG (0, 2, 4). There is no PPG (1, 3, 5).

### (2) Register list

	bit 15	bit 0
General control register 10 (GCN10)	<input type="text"/>	
General control register 20 (GCN20)	<input type="text"/>	
Timer register (PTMR0 to PTMR5)	<input type="text"/>	
Cycle setting register (PCSR0 to PCSR5)	<input type="text"/>	
Duty setting register (PDUT0)	<input type="text"/>	

# MB91350A Series

(3) Block diagram (overall configuration for 1 channel)

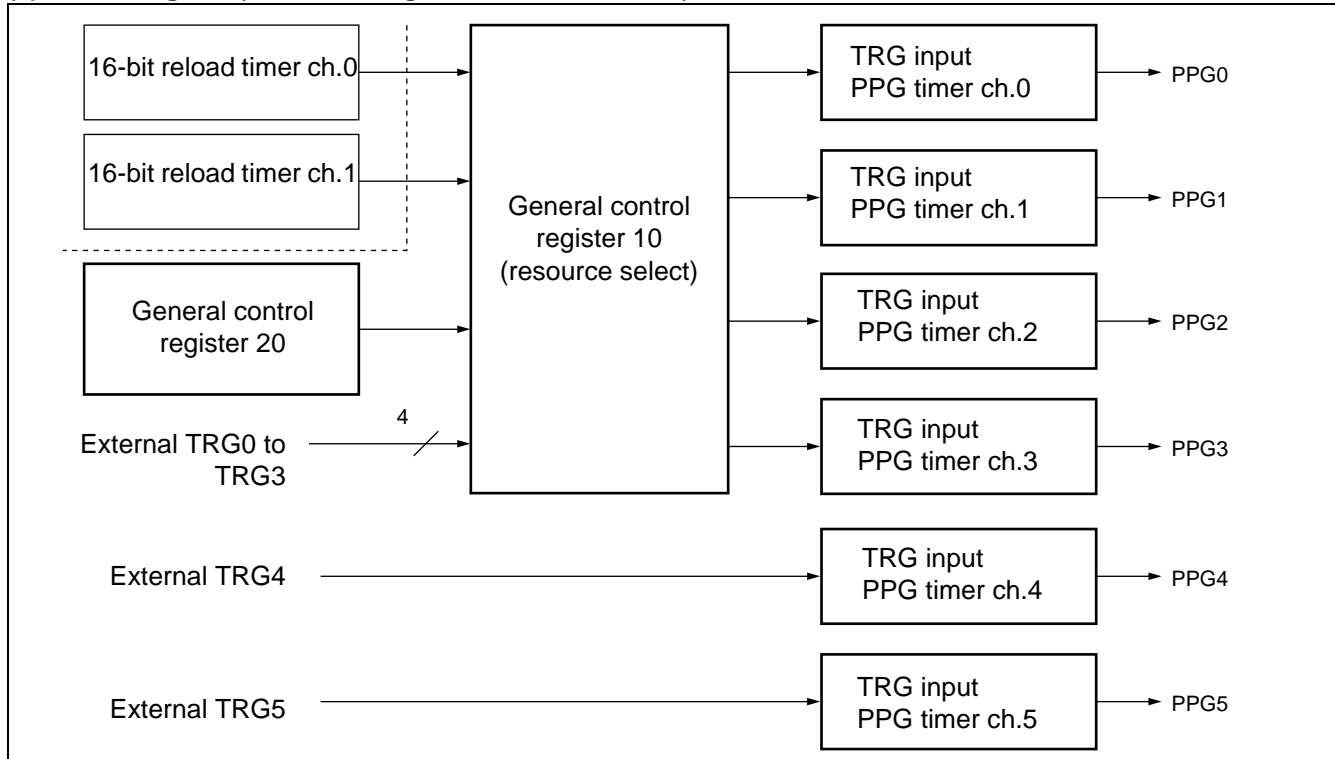

Note : The MB91F353A/353A/352A/351A does not have PPG1, PPG3, PPG5 and external TRG5.

## 7. U-TIMER (16-bit timer for UART baud rate generation)

### (1) Description

The U-TIMER is a 16-bit timer for generating the baud rate for the UART. An arbitrary baud rate can be set depending on the combination of the chip operating frequency and U-TIMER reload value.

The MB91F353A/353A/352A/351A contains 4 channels of this timer.

The MB91F355A/F356B/F357B/355A/354A/V350A contains 5 channels of this timer.

### (2) Register list

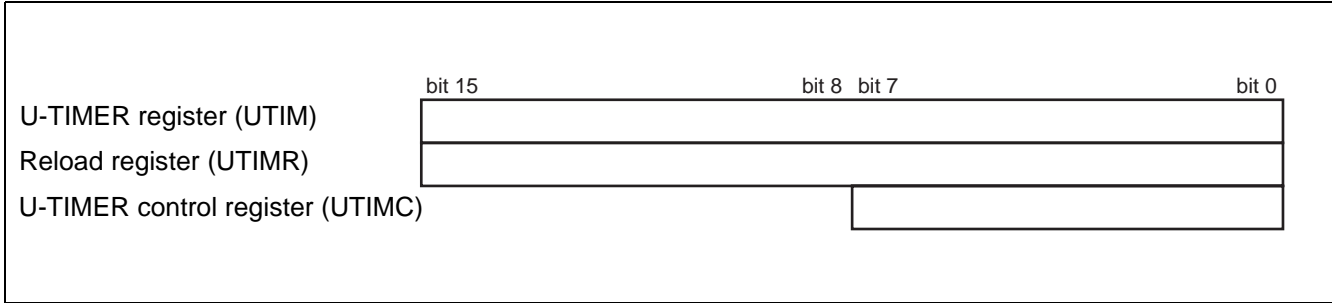

### (3) Block diagram

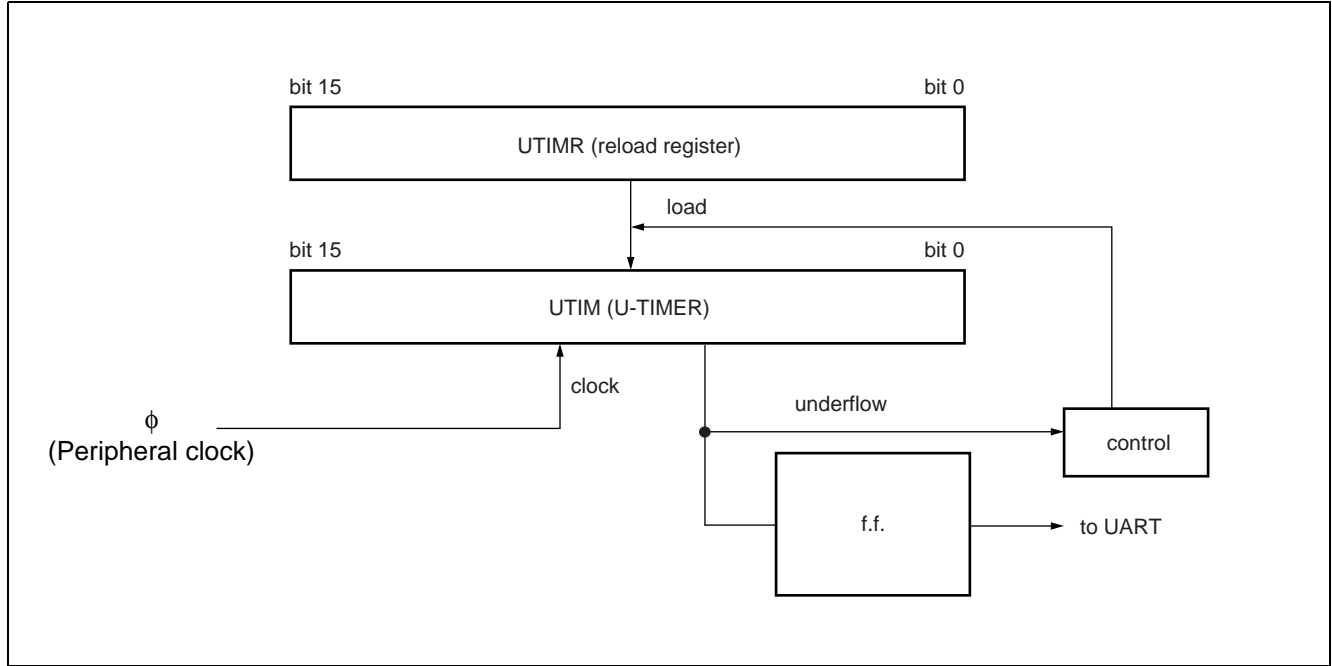

# MB91350A Series

## 8. UART

### (1) Description

The UART is a serial I/O port for asynchronous (start-stop) or CLK synchronous communication. This module has the features listed below.

The MB91F353A/353A/352A/351A contains 4 channels of UART.

The MB91F355A/F356B/F357B/355A/354A/V350A contains 5 channels of UART.

- Full duplex double buffer
- Asynchronous (start-stop synchronized) or CLK synchronized transmission
- Supports multi-processor mode
- Completely programmable baud rate.  
Arbitrary baud rate set by built-in timer (Refer to the section for "U-timer".)
- Variable baud rate can be input from an external clock.
- Error detection functions (parity, framing, overrun)
- Transmission signal format is NRZ
- UART (ch.0 to ch.2) can start DMA transfers using interrupts (ch.3 and ch.4 cannot start DMA transfers).
- Capable of clearing DMAC interrupt source by writing to DRCL register

### (2) Register list

#### Serial input register/serial output register (SIDR/SODR)

bit 7	bit 6	bit 5	bit 4	bit 3	bit 2	bit 1	bit 0
D7	D6	D5	D4	D3	D2	D1	D0

#### Serial status register (SSR)

bit 7	bit 6	bit 5	bit 4	bit 3	bit 2	bit 1	bit 0
PE	ORE	FRE	RDRF	TDRE	BDS	RIE	TIE

#### Serial mode register (SMR)

bit 7	bit 6	bit 5	bit 4	bit 3	bit 2	bit 1	bit 0
MD1	MD0	—	—	CS0	—	—	—

#### Serial control register (SCR)

bit 7	bit 6	bit 5	bit 4	bit 3	bit 2	bit 1	bit 0
PEN	P	SBL	CL	A/D	REC	RXE	TXE

#### DRCL register (DRCL)

bit 7	bit 6	bit 5	bit 4	bit 3	bit 2	bit 1	bit 0
—	—	—	—	—	—	—	—

## (3) Block diagram

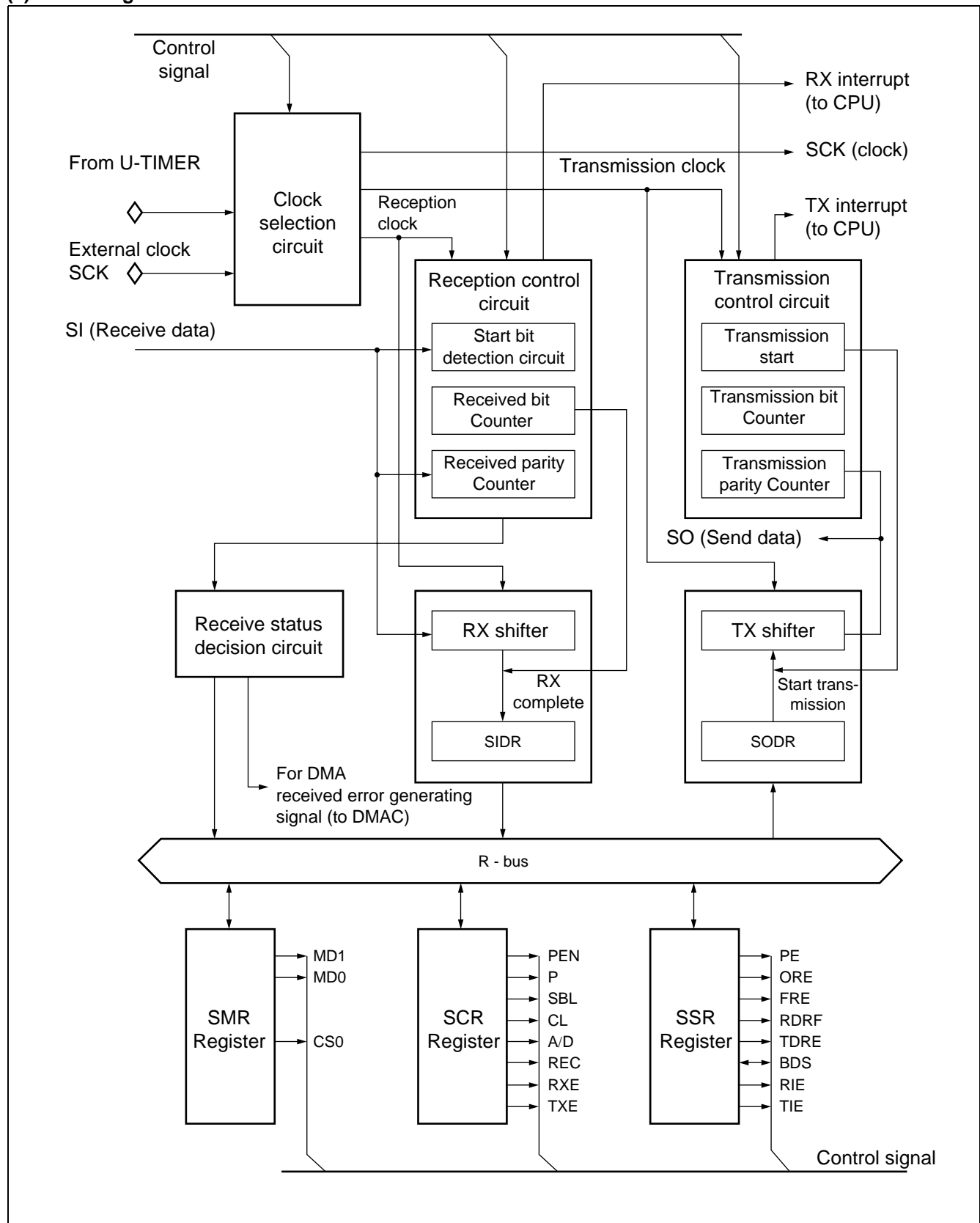

# MB91350A Series

## 9. Extended I/O serial interface (SIO)

### (1) Description

This block is an 8-bit × 1 channel serial I/O interface that allows data transfer using clock synchronization.

LSB-first or MSB-first transfer mode can be selected for data transfer.

The MB91F353A/353A/352A/351A contains 2 channels of this SIO.

The MB91F355A/F356B/F357B/355A/354A/V350A contains 3 channels of this SIO.

The serial I/O interface operates in 2 modes :

- Internal shift clock mode : Data is transferred synchronized with the internal clock.
- External shift clock mode : Data is transferred synchronized with a clock supplied via the external pin (SCK).  
In this mode, data can also be transferred using CPU instructions by operating the general-purpose port that shares the external pin (SCK) .

### (2) Register list

#### Serial mode control status register (SMCS)

bit 15	bit 14	bit 13	bit 12	bit 11	bit 10	bit 9	bit 8
SMD2	SMD1	SMD0	SIE	SIR	BUSY	STOP	STRT
bit 7	bit 6	bit 5	bit 4	bit 3	bit 2	bit 1	bit 0
—	—	—	—	MODE	BDS	—	—

#### SIO test register (SES)

bit 15	bit 14	bit 13	bit 12	bit 11	bit 10	bit 9	bit 8
—	—	—	—	—	—	TST1	TST0

#### SDR (Serial Data Register) (SDR)

bit 7	bit 6	bit 5	bit 4	bit 3	bit 2	bit 1	bit 0
D7	D6	D5	D4	D3	D2	D1	D0

#### SIO prescaler control register (CDCR)

bit 15	bit 14	bit 13	bit 12	bit 11	bit 10	bit 9	bit 8
MD	—	—	—	DIV3	DIV2	DIV1	DIV0

#### DMAC interrupt source clear register (SRCL)

bit 7	bit 6	bit 5	bit 4	bit 3	bit 2	bit 1	bit 0
—	—	—	—	—	—	—	—

(3) Block diagram

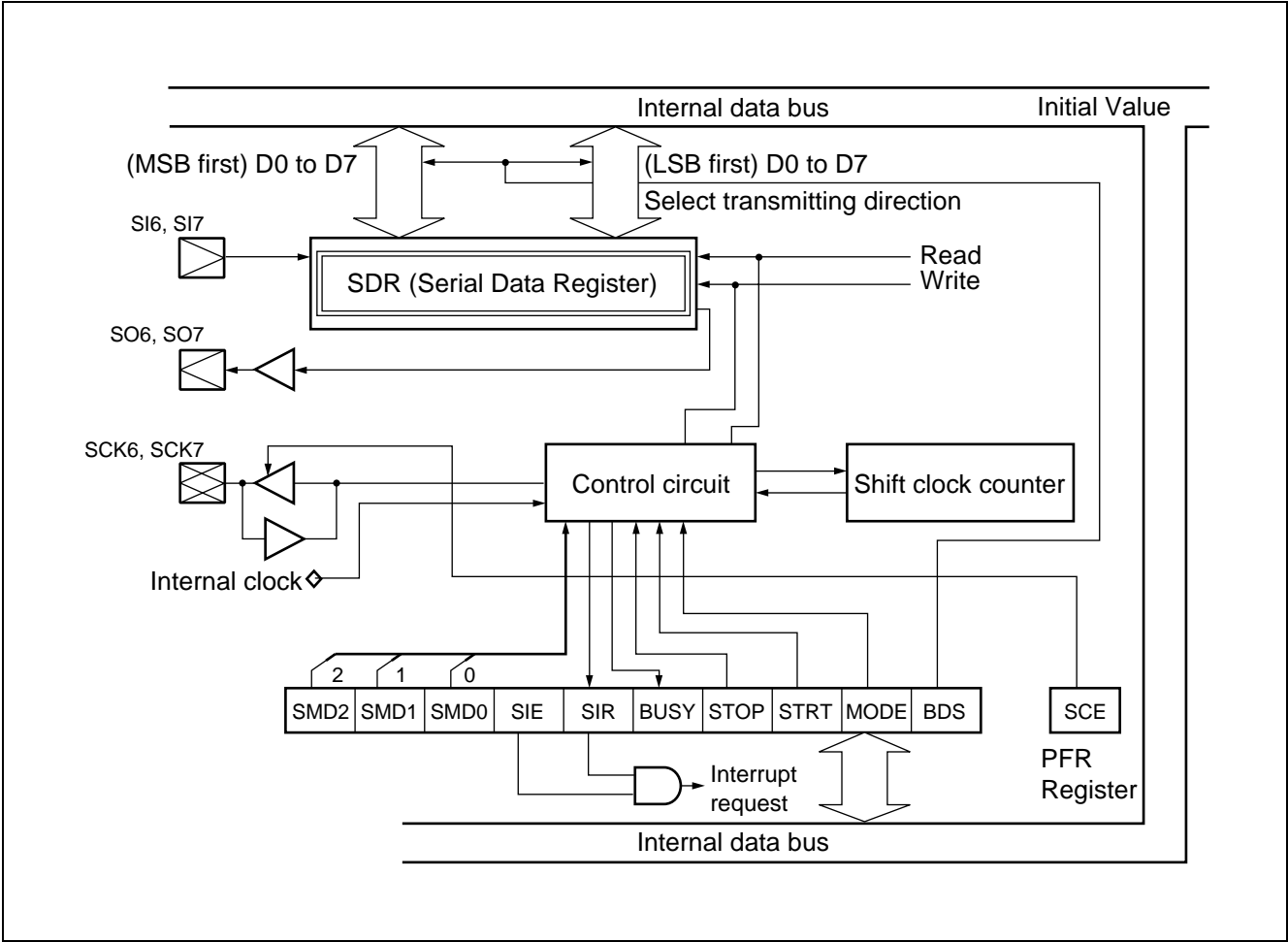

## 10. 16-bit free-run timer

### (1) Description

The 16-bit free-run timer consists of a 16-bit up counter, control register, and status register. The count values of this timer are used as the base timer for the output compare and input capture modules.

- Four count clock frequencies are available.
- An interrupt can be generated on counter overflow.
- The counter can be initialized upon a match with compare register 0 of the output compare unit, depending on the mode.

### (2) Register list

#### Timer data register (upper) (TCDT)

bit 15	bit 14	bit 13	bit 12	bit 11	bit 10	bit 9	bit 8
T15	T14	T13	T12	T11	T10	T09	T08

#### Timer data register (lower) (TCDT)

bit 7	bit 6	bit 5	bit 4	bit 3	bit 2	bit 1	bit 0
T07	T06	T05	T04	T03	T02	T01	T00

#### Timer control status register (lower) (TCCS)

bit 7	bit 6	bit 5	bit 4	bit 3	bit 2	bit 1	bit 0
ECLK	IVF	IVFE	STOP	MODE	CLR	CLK1	CLK0

### (3) Block diagram

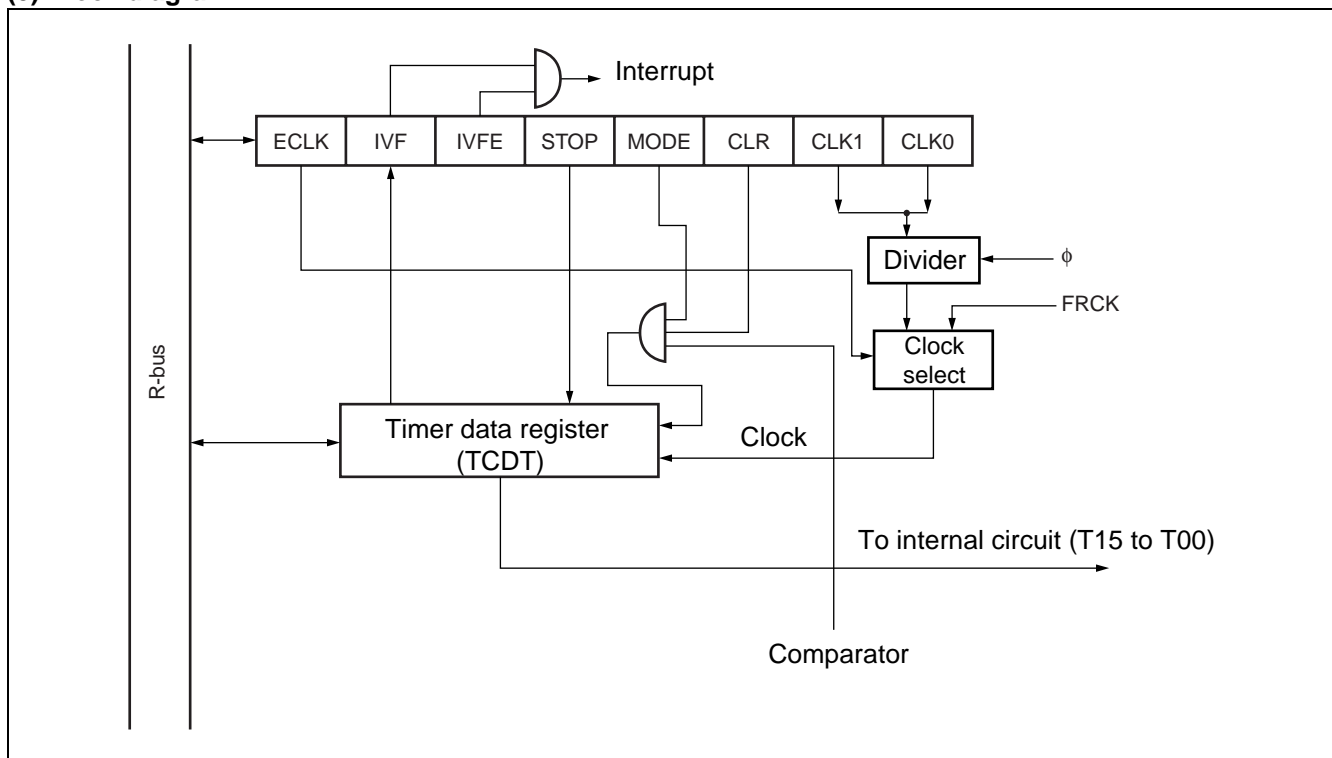

## 11. Input Capture

### (1) Description

This module detects the rising or falling edge or both edges of an external input signal and then, stores the value of the 16-bit free-run timer in a register. In addition, the module can generate an interrupt upon detection of an edge.

The input capture module consists of input capture data registers and a control register. Each input capture unit has a corresponding external input pin.

- The detection edge of the external input can be selected from among 3 types.
  - Rising edge
  - Falling edge
  - Both edges
- An interrupt can be generated upon detection of a valid edge in the external input.

### (2) Register list

#### Input capture data register (upper) (IPCP)

bit 15	bit 14	bit 13	bit 12	bit 11	bit 10	bit 9	bit 8
CP15	CP14	CP13	CP12	CP11	CP10	CP09	CP08

#### Input capture data register (lower) (IPCP)

bit 7	bit 6	bit 5	bit 4	bit 3	bit 2	bit 1	bit 0
CP07	CP06	CP05	CP04	CP03	CP02	CP01	CP00

#### Input capture control register (ICS23)

bit 7	bit 6	bit 5	bit 4	bit 3	bit 2	bit 1	bit 0
ICP3	ICP2	ICE3	ICE2	EG31	EG30	EG21	EG20

#### Input capture control register (ICS01)

bit 7	bit 6	bit 5	bit 4	bit 3	bit 2	bit 1	bit 0
ICP1	ICP0	ICE1	ICE0	EG11	EG10	EG01	EG00

## (3) Block diagram

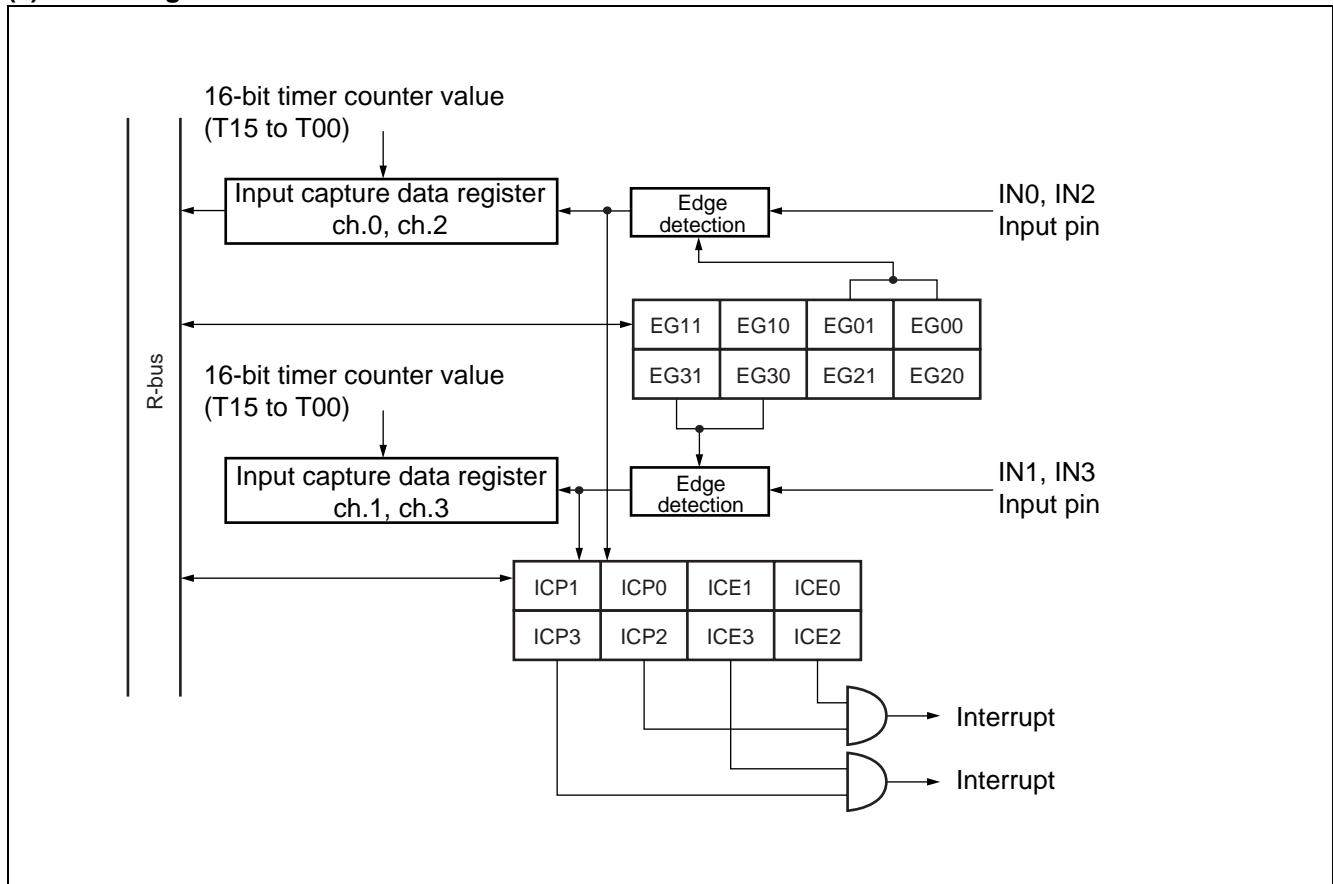

## 12. Output Compare

### (1) Description

The output compare module consists of a 16-bit compare register, compare output latch, and control register. When the 16-bit free-run timer value matches the compare register value, the output level is inverted and an interrupt is issued.

The MB91F353A/353A/352A/351A contains 2 channels of this block.

The MB91F355A/F356B/F357B/355A/354A/V350A contains 8 channels of this block.

This module has the following features.

- The output compare is able to operate independent of each of 8 compare register. There are output pins and interrupt flags corresponding to each of the compare registers.
- A pair of compare registers can be used to control the output terminal.  
The output terminal is reversed by using two compare registers.
- Capable of setting the initial value for each output pin.
- Interrupts can be generated upon a compare match.
- The ch.0 compare register is used as the compare clear register for the 16-bit free-run timer.

### (2) Register list

#### Compare register (OCCP)

bit 15	bit 14	bit 13	bit 12	bit 11	bit 10	bit 9	bit 8
C15	C14	C13	C12	C11	C10	C09	C08

#### Compare register (OCCP)

bit 7	bit 6	bit 5	bit 4	bit 3	bit 2	bit 1	bit 0
C07	C06	C05	C04	C03	C02	C01	C00

#### Output control register (OCS01)

bit 15	bit 14	bit 13	bit 12	bit 11	bit 10	bit 9	bit 8
—	—	—	CMOD	—	—	OTD1	OTD0

#### Output control register (OCS23)

bit 7	bit 6	bit 5	bit 4	bit 3	bit 2	bit 1	bit 0
ICP1	ICP0	ICE1	ICE0	—	—	CST1	CST0

## (3) Block diagram

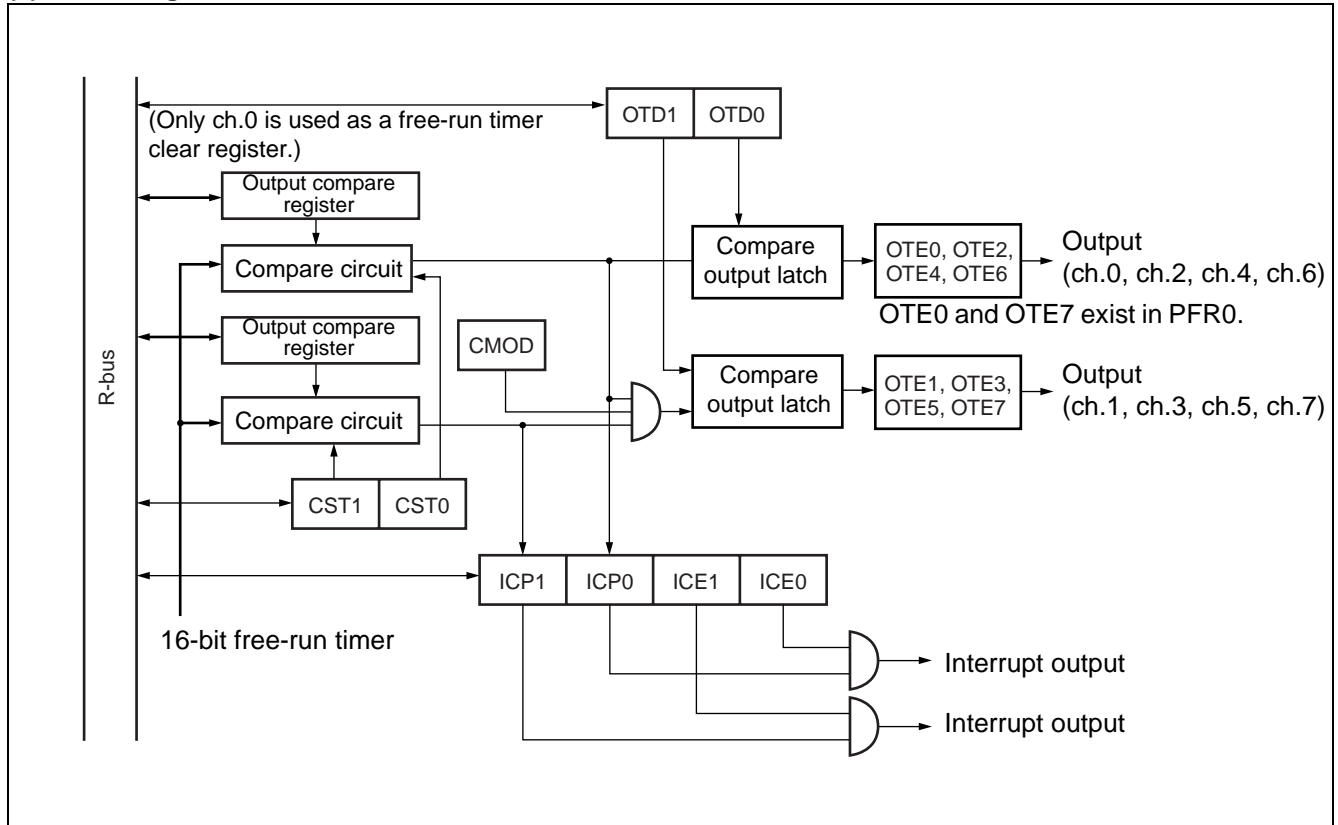

## 13. I<sup>2</sup>C Interface

### (1) Description

The I<sup>2</sup>C interface is a serial I/O port supporting the Inter-IC bus, operating as a master/slave device on the I<sup>2</sup>C bus. It has the following features :

- Master/slave transmission and reception
- Arbitration function
- Clock sync function
- Slave address and general call address detection function
- Transmission direction detection function
- Repeated start condition generation and detection function
- Bus error detection function
- 10-bit/7-bit slave address
- Slave address receive acknowledge control when in master mode
- Support for composite slave addresses
- Capable of interrupt when a transmission or bus error occurs
- Standard mode (Max 100 kbps)/High speed mode (Max 400 kbps) supported

# MB91350A Series

## (2) Register list

Bus control register (IBCR)

bit 15	bit 14	bit 13	bit 12	bit 11	bit 10	bit 9	bit 8
BER	BEIE	SCC	MSS	ACK	GCAA	INTE	INT

Bus status register (IBSR)

bit 7	bit 6	bit 5	bit 4	bit 3	bit 2	bit 1	bit 0
BB	RSC	AL	LRB	TRX	AAS	GCA	ADT

10-bit slave address register (ITBA)

bit 15	bit 14	bit 13	bit 12	bit 11	bit 10	bit 9	bit 8
—	—	—	—	—	—	TA9	TA8

bit 7	bit 6	bit 5	bit 4	bit 3	bit 2	bit 1	bit 0
TA7	TA6	TA5	TA4	TA3	TA2	TA1	TA0

10-bit slave address mask register (ITMK)

bit 15	bit 14	bit 13	bit 12	bit 11	bit 10	bit 9	bit 8
ENTB	RAL	—	—	—	—	TM9	TM8

bit 7	bit 6	bit 5	bit 4	bit 3	bit 2	bit 1	bit 0
TM7	TM6	TM5	TM4	TM3	TM2	TM1	TM0

7-bit slave address register (ISBA)

bit 7	bit 6	bit 5	bit 4	bit 3	bit 2	bit 1	bit 0
—	SA6	SA5	SA4	SA3	SA2	SA1	SA0

7-bit slave address mask register (ISMK)

bit 15	bit 14	bit 13	bit 12	bit 11	bit 10	bit 9	bit 8
ENSB	SM6	SM5	SM4	SM3	SM2	SM1	SM0

D/A data register (IDAR)

bit 7	bit 6	bit 5	bit 4	bit 3	bit 2	bit 1	bit 0
D7	D6	D5	D4	D3	D2	D1	D0

Clock control register (ICCR)

bit 15	bit 14	bit 13	bit 12	bit 11	bit 10	bit 9	bit 8
TEST	—	EN	CS4	CS3	CS2	CS1	CS0

Clock disable register (IDBL)

bit 7	bit 6	bit 5	bit 4	bit 3	bit 2	bit 1	bit 0
—	—	—	—	—	—	—	DBL

## (3) Block diagram

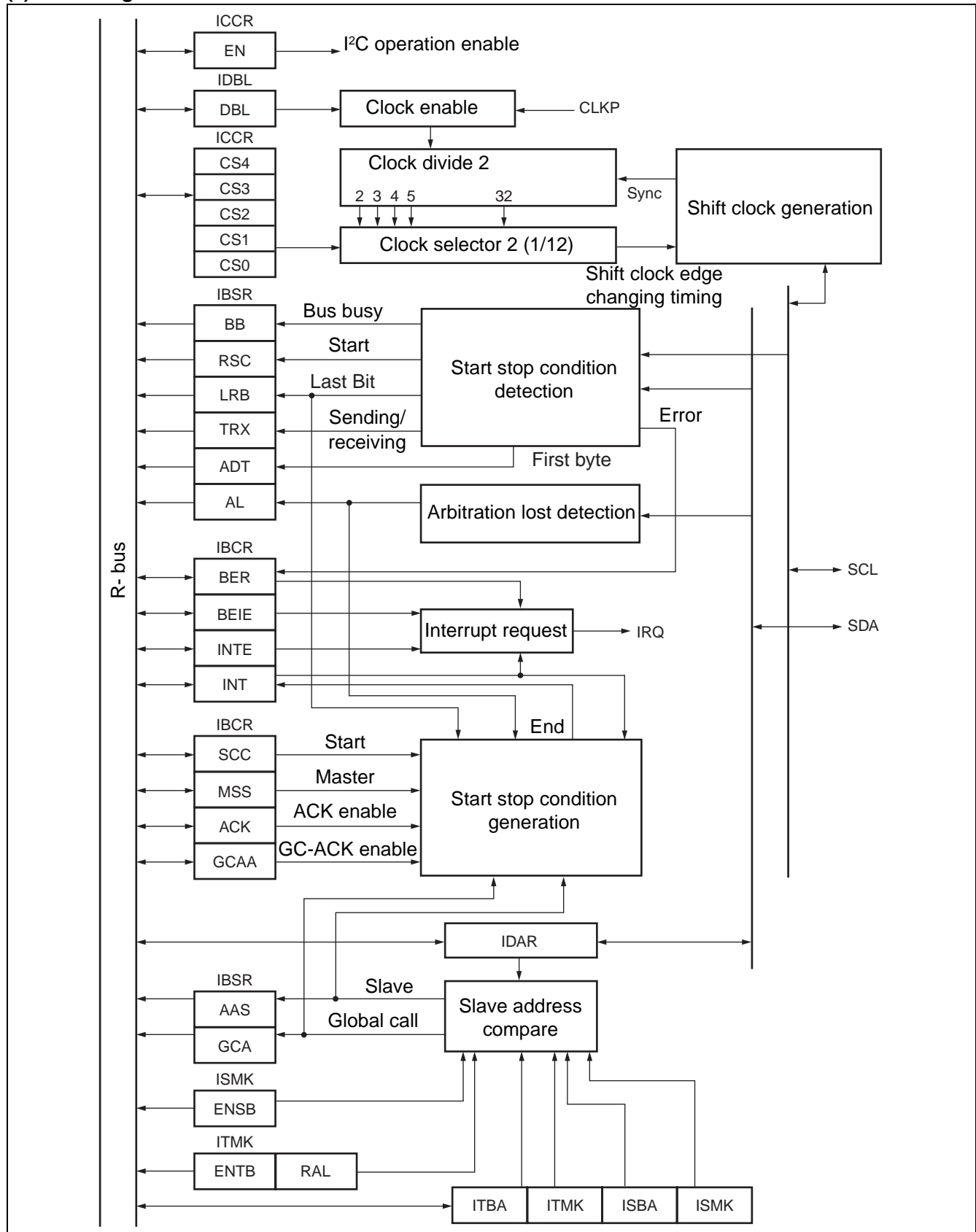

# MB91350A Series

## 14. A/D converter

### (1) Description

The A/D converter converts the analog input voltage into a digital value. It has the following features :

- Conversion time : 1.48  $\mu$ s minimum per channel
- Employing serial / parallel conversion type for sample and hold circuit.
- 10-bit resolution (switchable between 8 and 10 bits)
- Programmatic selection of the analog input from among 12 channels (The MB91F353A/353A/352A/351A are input 8 channels.)
- Conversion mode
  - Single conversion mode : Converts 1 selected channel a single time.
  - Scan conversion mode : Scanning conversion of up to 4 channels.
- Converted data is stored in a data buffer (a total of 4 data buffers) .
- An interrupt request to the CPU can be generated upon completion of A/D conversion. The interrupt can be used to start a DMA transfer.
- The startup source can be selected from among software, external trigger (falling edge), and reload timer ch.2 (rising edge).

### (2) Register list

	bit 15	bit 8	bit 7	bit 0
Control status register (ADCS2/ADCS1)	ADCS2		ADCS1	
Conversion time setting register (ADCT)				
Converted data register 0 (ADTH0/ADTL0)	ADTH0		ADTL0	
Converted data register 1 (ADTH1/ADTL1)	ADTH1		ADTL1	
Converted data register 2 (ADTH2/ADTL2)	ADTH2		ADTL2	
Converted data register 3 (ADTH3/ADTL3)	ADTH3		ADTL3	

### (3) Block diagram

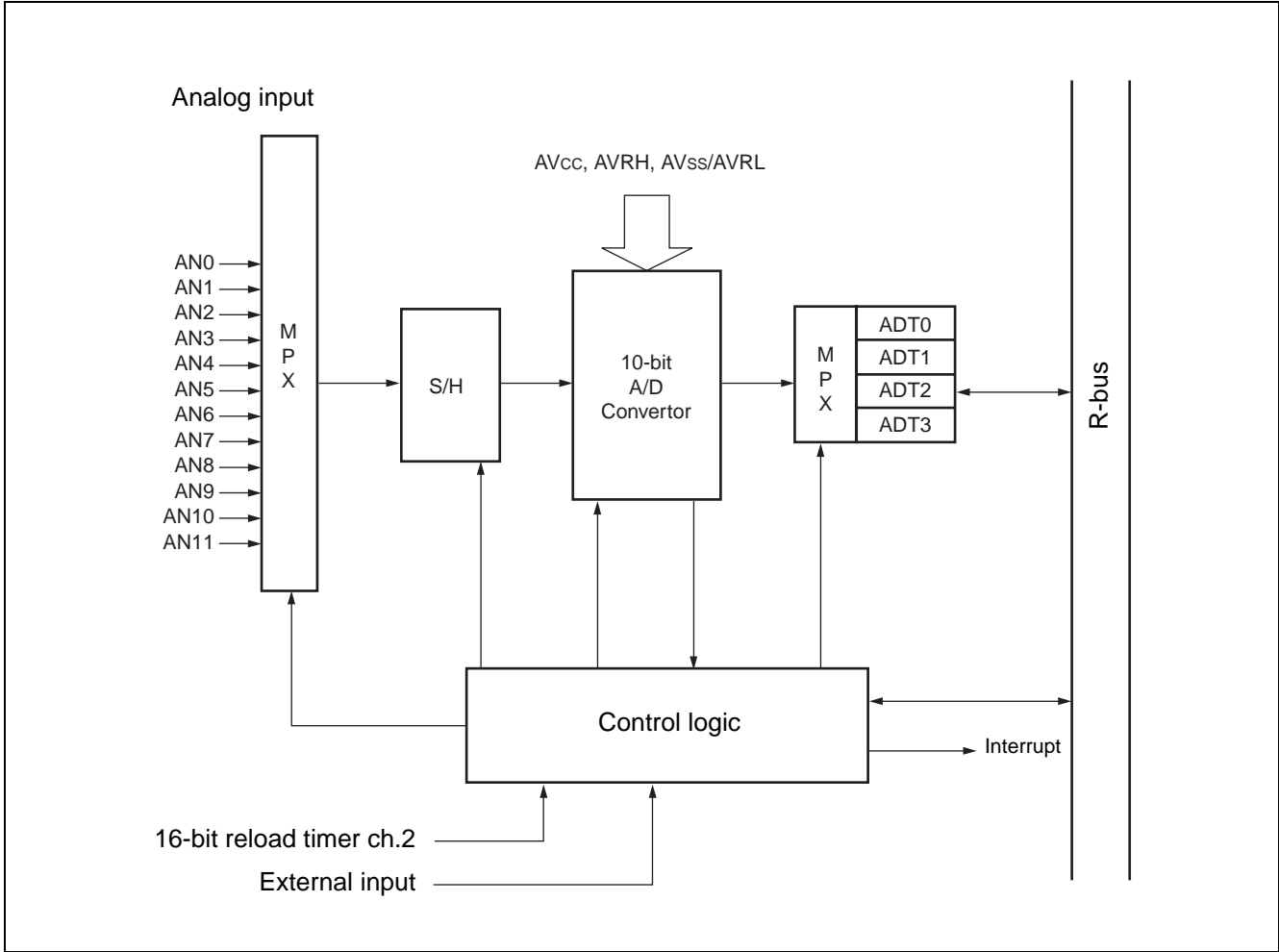

Note : The MB91F353A/353A/352A/351A does not have inputs AN8 to AN11.

# MB91350A Series

## 15. 8-bit D/A converter

### (1) Description

This block contains 3 channels of 8-bit D/A converters and D/A converter registers that can be used to control the independent output of each channel. The block has the following features.

- Power saving function
- 3.3 V interface

Note : The MB91F353A/353A/352A/351A contains 2 channels of D/A converter.

### (2) Register list

#### D/A data register 0 to 2 (DADR0 to DADR2)

bit 7	bit 6	bit 5	bit 4	bit 3	bit 2	bit 1	bit 0
DA7	DA6	DA5	DA4	DA3	DA2	DA1	DA0

#### D/A control register 0 to 2 (DACR0 to DACR2)

bit 7	bit 6	bit 5	bit 4	bit 3	bit 2	bit 1	bit 0
—	—	—	—	—	—	—	DAE

Note : The MB91F353A/353A/352A/351A does not have DADR2, DACR2.

### (3) Block diagram

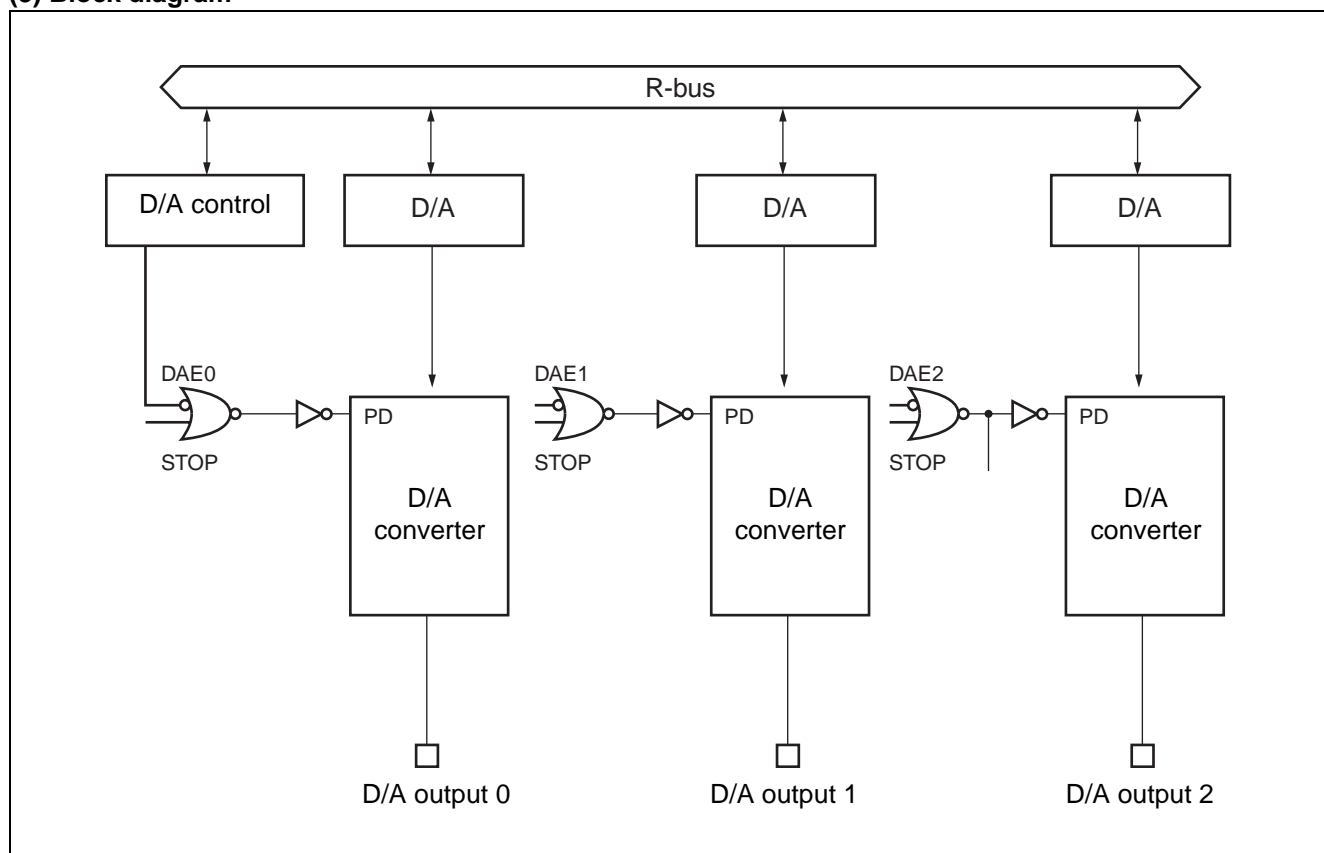

## 16. DMAC (DMA Controller)

### (1) Description

This module provides direct memory access (DMA) transfers in the FR family devices.

The DMAC enables high speed transfers for various data without CPU intervention, thereby improving system performance.

#### • Hardware configuration

The main components of this module are as follows :

- Independent DMA channels × 5 channels
- 5 channels independent access control circuits
- 32-bit address registers (Supports reloading : 2 per channel)
- 16-bit transfer count registers (Supports reloading : 1 per channel)
- 4-bit block count registers (1 per channel)
- External transfer request input pins : DREQ0, DREQ1, and DREQ2. For ch.0 to ch.2 only  
**Note** : The MB91F353A/353A/352A/351A do not have an external interface.
- External transfer request acceptance output pins : DACK0, DACK1, and DACK2. For ch.0 to ch.2 only  
**Note** : The MB91F353A/353A/352A/351A do not have an external interface.
- DMA end output pins : DEOP0, DEOP1, and DEOP2. For ch.0 to ch.2 only  
**Note** : The MB91F353A/353A/352A/351A do not have an external interface.
- Fly-by transfer (memory to I/O and I/O to memory). For ch.0 to ch.2 only  
**Note** : The MB91F353A/353A/352A/351A do not support fly-by transfer.
- 2-cycle transfer

#### • Main functions

This module has the following major functions for data transfer :

- Supports data transfer over multiple independent channels (5 channels)

(1) Priority order (ch.0 > ch.1 > ch.2 > ch.3 > ch.4)

(2) Order can be reversed for ch.0 and ch.1

(3) DMAC activation triggers

- External dedicated pin input (edge detection/level detection for ch.0 to ch.2 only)  
**Note** : The MB91F353A/353A/352A/351A do not have an external interface.
- Internal peripheral request (Interrupt request sharing, including external interrupts)
- Software request (register write)

(4) Transmission mode

- Demand transfer, burst transfer, step transfer, or block transfer
- Addressing mode : 32-bit full addressing (increment, decrement, or fixed)  
(address increment can be in the range - 255 to + 255)
- Data length : Byte, halfword, or word
- Single-shot or reload operation selectable

# MB91350A Series

## (2) Register Description

			bit 31	bit 0
ch.0 Control/status	Register A	(DMACA0)	<input type="text"/>	
	Register B	(DMACB0)	<input type="text"/>	
ch.1 Control/status	Register A	(DMACA1)	<input type="text"/>	
	Register B	(DMACB1)	<input type="text"/>	
ch.2 Control/status	Register A	(DMACA2)	<input type="text"/>	
	Register B	(DMACB2)	<input type="text"/>	
ch.3 Control/status	Register A	(DMACA3)	<input type="text"/>	
	Register B	(DMACB3)	<input type="text"/>	
ch.4 Control/status	Register A	(DMACA4)	<input type="text"/>	
	Register B	(DMACB4)	<input type="text"/>	
Overall control register		(DMACR)	<input type="text"/>	
ch.0 Transfer source address register		(DMASA0)	<input type="text"/>	
		(DMADA0)	<input type="text"/>	
ch.1 Transfer source address register		(DMASA1)	<input type="text"/>	
		(DMADA1)	<input type="text"/>	
ch.2 Transfer source address register		(DMASA2)	<input type="text"/>	
		(DMADA2)	<input type="text"/>	
ch.3 Transfer source address register		(DMASA3)	<input type="text"/>	
		(DMADA3)	<input type="text"/>	
ch.4 Transfer source address register		(DMASA4)	<input type="text"/>	
		(DMADA4)	<input type="text"/>	

## (3) Block diagram

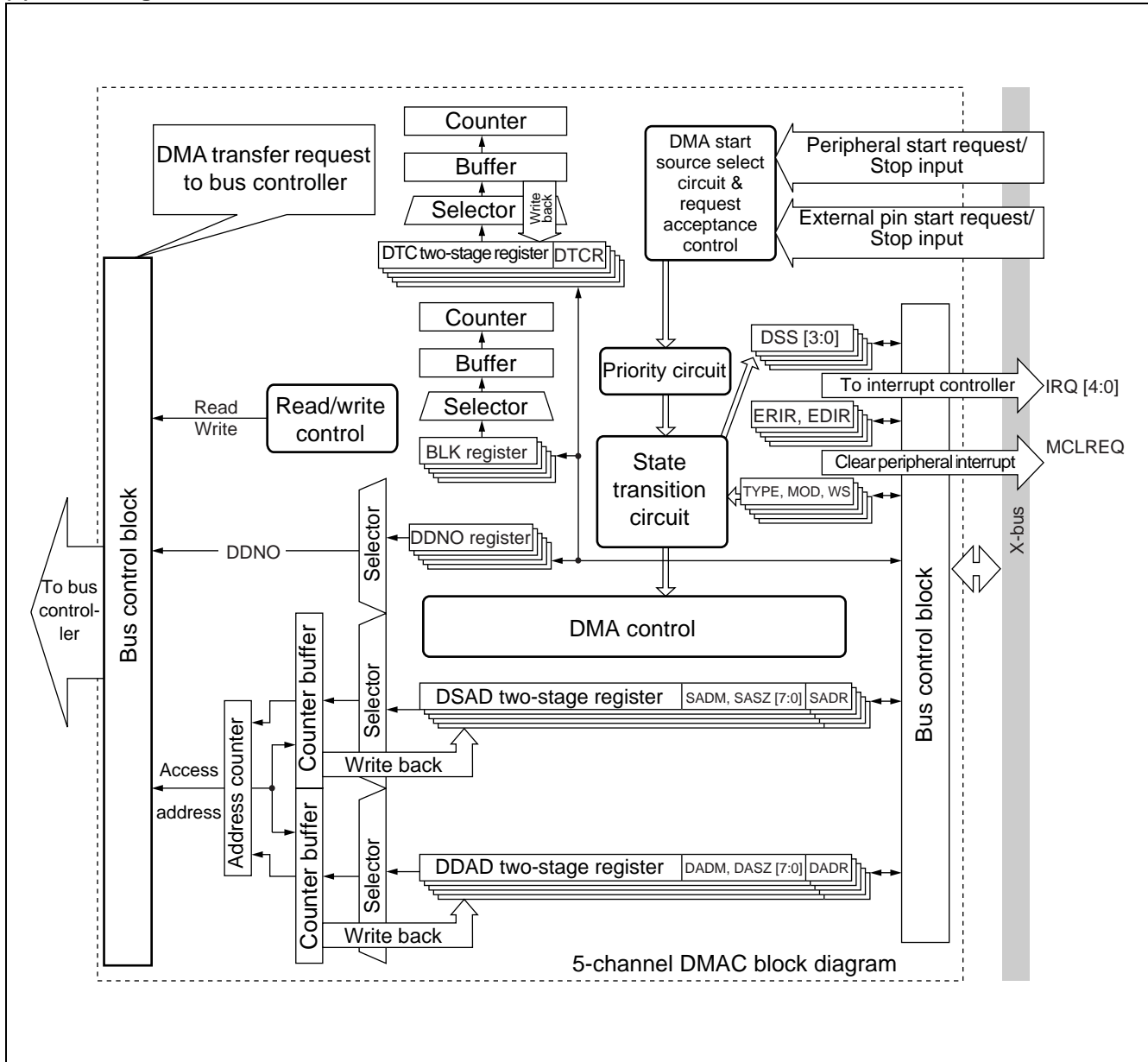

# MB91350A Series

## ■ ELECTRICAL CHARACTERISTICS

### 1. Absolute Maximum Rating

Parameter	Symbol	Rating		Unit	Remarks
		Min	Max		
Power supply voltage*1	V <sub>CC</sub>	V <sub>SS</sub> - 0.5	V <sub>SS</sub> + 4.0	V	*2
Analog power supply voltage*1	DAVC	V <sub>SS</sub> - 0.5	V <sub>SS</sub> + 4.0	V	*3
Analog power supply voltage*1	AV <sub>CC</sub>	V <sub>SS</sub> - 0.5	V <sub>SS</sub> + 4.0	V	*3
Analog reference voltage*1	AVRH	V <sub>SS</sub> - 0.5	V <sub>SS</sub> + 4.0	V	*3
Input voltage*1	V <sub>I</sub>	V <sub>SS</sub> - 0.5	V <sub>CC</sub> + 0.5	V	*8
Input voltage (N-ch open-drain) *1	V <sub>IND</sub>	V <sub>SS</sub> - 0.5	V <sub>SS</sub> + 5.5	V	
Analog pin input voltage*1	V <sub>IA</sub>	V <sub>SS</sub> - 0.5	AV <sub>CC</sub> + 0.5	V	*8
Output voltage*1	V <sub>O</sub>	V <sub>SS</sub> - 0.5	V <sub>CC</sub> + 0.5	V	
Maximum clamp current	I <sub>CLAMP</sub>	- 2.0	+ 2.0	mA	*7
Total maximum clamp current	Σ I <sub>CLAMP</sub>	—	20	mA	*7
"L" level maximum output current	I <sub>OL</sub>	—	10	mA	*4
"L" level maximum output current (N-ch open-drain)	I <sub>OLND</sub>	—	20	mA	
"L" level average output current	I <sub>OLAV</sub>	—	8	mA	*5
"L" level average output current (N-ch open-drain)	I <sub>OLAVND</sub>	—	15	mA	
"L" level total maximum output current	ΣI <sub>OL</sub>	—	100	mA	
"L" level total average output current	ΣI <sub>OLAV</sub>	—	50	mA	*6
"H" level maximum output current	I <sub>OH</sub>	—	- 10	mA	*4
"H" level average output current	I <sub>OHAV</sub>	—	- 4	mA	*5
"H" level total maximum output current	ΣI <sub>OH</sub>	—	- 50	mA	
"H" level total average output current	ΣI <sub>OHAV</sub>	—	- 20	mA	*6
Power consumption	P <sub>D</sub>	—	850	mW	
Operating temperature	T <sub>a</sub>	- 40	+ 85	°C	
Storage temperature	T <sub>STG</sub>	—	+ 125	°C	

\*1 : The parameter is based on V<sub>SS</sub> = DAVS = AV<sub>SS</sub> = 0 V.

\*2 : V<sub>CC</sub> must not be lower than V<sub>SS</sub> - 0.3 V.

\*3 : Be careful not to exceed "V<sub>CC</sub> + 0.3 V" , for example, when the power is turned on.

\*4 : The maximum output current is the peak value for a single pin.

\*5 : The average output current is the average current for a single pin over a period of 100 ms.

\*6 : The total average output current is the average current for all pins over a period of 100 ms.

(Continued)

(Continued)

\*7 : • Relevant pins : Ports 2, 3, 4, 5, 6, 8, 9, A, H, I, K, M, N, O and AN (A/D input) : MB91F353A/353A/352A/351A  
 Ports 2, 3, 4, 5, 6, 8, 9, A, B, C, G, H, I, J, K, M, N, O, P and AN (A/D input) :  
 MB91F355A/F356B/F357B/355A/354A

- Use within recommended operating conditions.
- Use at DC voltage (current).
- + B signals are input signals that exceed the  $V_{CC}$  voltage.
- A limiting resistance should always be applied to +B signals by connecting the resistance between the +B signal and the microcontroller.
- The value of the limiting resistance should be set so that when the + B signal is applied the input current to the microcontroller pin does not exceed rated values, either instantaneously or for prolonged periods.
- Note that when the microcontroller drive current is low, such as in low power consumption mode, the + B input potential can increase the potential at the  $V_{CC}$  pin via a protective diode, possibly affecting other devices.
- Note that if a + B input is applied when the microcontroller is off (not fixed at 0 V), power is supplied through the pin, possibly causing the microcontroller to partially operate.
- Note that if a + B input is applied when the power supply is turned on, power is supplied through the pin, possibly resulting in a power-supply voltage at which power-on reset does not work.
- Ensure that a + B input pin does not form an open circuit.
- Note that analog I/O pins other than the A/D input pins (such as the LCD drive and comparator input pins) cannot input + B.
- Sample recommended circuits :

• Input/output equivalent circuits

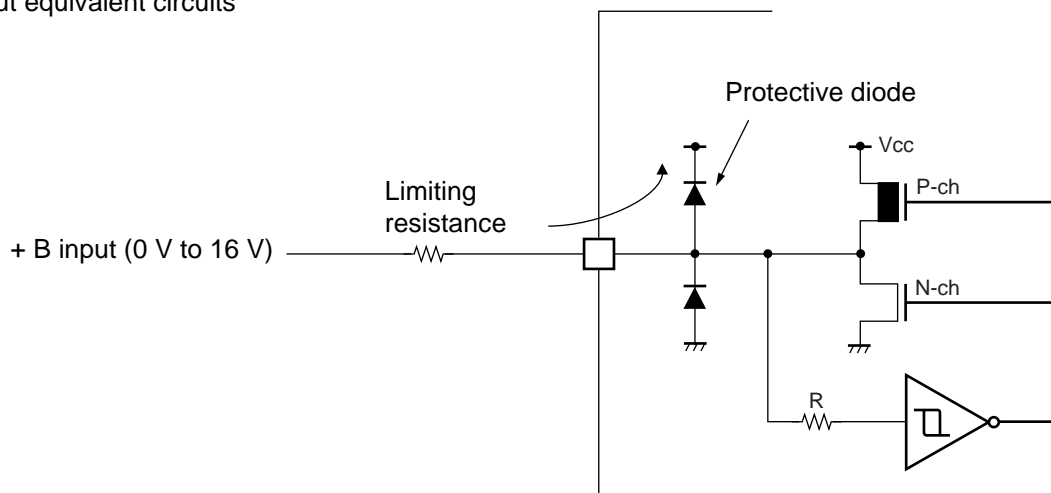

\*8 :  $V_I$  must not exceed the rated voltage. However, If the maximum current to/from an input is limited by some means using external components, the  $I_{CLAMP}$  rating supersedes the  $V_I$  rating.

**WARNING:** Semiconductor devices can be permanently damaged by application of stress (voltage, current, temperature, etc.) in excess of absolute maximum ratings. Do not exceed these ratings.

# MB91350A Series

## 2. Recommended Operating Conditions

( Other than MB91F356B/F357B)

(V<sub>SS</sub> = DAVS = AV<sub>SS</sub> = 0 V)

Parameter	Symbol	Value		Unit	Remarks
		Min	Max		
Power supply voltage	V <sub>CC</sub>	3.0	3.6	V	During normal operation
	V <sub>CC</sub>	3.0	3.6	V	Hold RAM status at stop
Analog power supply voltage	DAVC	V <sub>SS</sub> - 0.3	V <sub>SS</sub> + 3.6	V	
	AV <sub>CC</sub>	V <sub>SS</sub> - 0.3	V <sub>SS</sub> + 3.6		
Analog reference voltage	AVRH	AV <sub>SS</sub>	AV <sub>CC</sub>	V	
Operating temperature	T <sub>a</sub>	- 40	+ 85	°C	

(MB91F356B/F357B only)

(V<sub>SS</sub> = DAVS = AV<sub>SS</sub> = 0 V)

Parameter	Symbol	Value		Unit	Remarks
		Min	Max		
Power supply voltage	V <sub>CC</sub>	2.7	3.6	V	During normal operation
	V <sub>CC</sub>	2.7	3.6	V	Hold RAM status at stop
	V <sub>CC</sub>	3.0	3.6	V	When writing or erasing Flash memory
Analog power supply voltage	DAVC	V <sub>SS</sub> - 0.3	V <sub>SS</sub> + 3.6	V	
	AV <sub>CC</sub>	V <sub>SS</sub> - 0.3	V <sub>SS</sub> + 3.6		
Analog reference voltage	AVRH	AV <sub>SS</sub>	AV <sub>CC</sub>	V	
Operating temperature	T <sub>a</sub>	- 40	+ 85	°C	When writing or erasing Flash memory*
		0	+70	°C	

\* : Including the F355A/F353A

**WARNING:** The recommended operating conditions are required in order to ensure the normal operation of the semiconductor device. All of the device's electrical characteristics are warranted when the device is operated within these ranges.

Always use semiconductor devices within their recommended operating condition ranges. Operation outside these ranges may adversely affect reliability and could result in device failure.

No warranty is made with respect to uses, operating conditions, or combinations not represented on the data sheet. Users considering application outside the listed conditions are advised to contact their representatives beforehand.

### 3. DC Characteristics

( $V_{CC} = 3.0\text{ V to }3.6\text{ V}$ ,  $V_{CC} = 2.7\text{ V to }3.6\text{ V}$  (MB91F356B/F357B only),  $V_{SS} = \text{DAVS} = \text{AV}_{SS} = 0\text{ V}$ ,  $T_a = -40\text{ }^\circ\text{C to }+85\text{ }^\circ\text{C}$ )

Parameter	Symbol	Pin name	Conditions	Value			Unit	Remarks	
				Min	Typ	Max			
"H" level input voltage	$V_{IH}$	Port 2, 3, 4, 5, 6, 9, A	—	$V_{CC} \times 0.65$	—	$V_{CC} + 0.3$	V	MB91F353A/353A/352A/351A	
		Port 2, 3, 4, 5, 6, 9, A, B, C						MB91F355A/F356B/F357B/355A/354A	
	$V_{IHS}$	Port 8, H, I, M, N, O, MD0, MD1, MD2, $\overline{\text{INIT}}$ , $\overline{\text{NMI}}$		$V_{CC} \times 0.8$				Hysteresis input MB91F353A/353A/352A/351A	
		Port 8, G, H, I, M, N, O, P, MD0, MD1, MD2, $\overline{\text{INIT}}$ , $\overline{\text{NMI}}$						Hysteresis input MB91F355A/F356B/F357B/355A/354A	
	$V_{IHST}$	Port K, L		5.25				Hysteresis input with-stand voltage of 5 V MB91F353A/353A/352A/351A	
		Port J, K, L						Hysteresis input with-stand voltage of 5 V MB91F355A/F356B/F357B/355A/354A	
"L" level input voltage	$V_{IL}$	Port 2, 3, 4, 5, 6, 9, A	—	$V_{SS}$	—	$V_{CC} \times 0.25$	V	MB91F353A/353A/352A/351A	
		Port 2, 3, 4, 5, 6, 9, A, B, C						MB91F355A/F356B/F357B/355A/354A	
	$V_{ILS}$	Port 8, H, I, M, N, O, MD0, MD1, MD2, $\overline{\text{INIT}}$ , $\overline{\text{NMI}}$						$V_{CC} \times 0.2$	Hysteresis input MB91F353A/353A/352A/351A
		Port 8, G, H, I, M, N, O, P, MD0, MD1, MD2, $\overline{\text{INIT}}$ , $\overline{\text{NMI}}$							Hysteresis input MB91F355A/F356B/F357B/355A/354A
	$V_{ILST}$	Port K, L						5.25	Hysteresis input with-stand voltage of 5 V MB91F353A/353A/352A/351A
		Port J, K, L							Hysteresis input with-stand voltage of 5 V MB91F355A/F356B/F357B/355A/354A

(Continued)

# MB91350A Series

( $V_{CC} = 3.0\text{ V to }3.6\text{ V}$ ,  $V_{CC} = 2.7\text{ V to }3.6\text{ V}$  (MB91F356B/F357B only),  $V_{SS} = \text{DAVS} = \text{AV}_{SS} = 0\text{ V}$ ,  $T_a = -40\text{ }^\circ\text{C to }+85\text{ }^\circ\text{C}$ )

Parameter	Symbol	Pin name	Conditions	Value			Unit	Remarks	
				Min	Typ	Max			
“H” level output voltage	$V_{OH}$	Port 2, 3, 4, 5, 6, 8, 9, A, H, I, J, K, M, N, O	$V_{CC} = 3.0\text{ V}$ , $I_{OH} = -4.0\text{ mA}$	$V_{CC} - 0.5$	—	$V_{CC}$	V	MB91F353A/ 353A/352A/351A	
		Port 2, 3, 4, 5, 6, 8, 9, A, B, C, G, H, I, J, K, M, N, O, P						MB91F355A/ F356B/F357B/ 355A/354A	
“L” level output voltage	$V_{OL1}$	Port 2, 3, 4, 5, 6, 8, 9, A, H, I, K, M, N, O	$V_{CC} = 3.0\text{ V}$ , $I_{OL} = 4.0\text{ mA}$	$V_{SS}$	—	0.4	V	MB91F353A/ 353A/352A/351A	
		Port 2, 3, 4, 5, 6, 8, 9, A, B, C, G, H, I, J, K, M, N, O, P						MB91F355A/ F356B/F357B/ 355A/354A	
	$V_{OL2}$	Port L	$V_{CC} = 3.0\text{ V}$ , $I_{OL} = 15.0\text{ mA}$					N-ch open-drain	
Input leak current (High-Z Output Leakage Current)	$I_{LI}$	All input pin	$V_{CC} = 3.6\text{ V}$ , $0 < V_I < V_{CC}$	-5	—	+5	$\mu\text{A}$		
Pull-up resistance	$R_{UP}$	Setting pin INIT, Pull Up	$V_{CC} = 3.6\text{ V}$ , $V_I = 0.45\text{ V}$	25	50	200	k $\Omega$		
Power supply current	$I_{CC}$	$V_{CC}$	$f_c = 12.5\text{ MHz}$ , $V_{CC} = 3.3\text{ V}$	Flash	—	160	220	mA	MB91F353A/ 353A/352A/351A Multiply by 4RUN When operating at CLKB : 50 MHz CLKT : 25 MHz CLKP : 25 MHz
				MASK		125	150		
				Flash		85	100		MB91F353A/ 353A/352A/351A Multiply by 2RUN When operating at CLKB : 25 MHz CLKT : 25 MHz CLKP : 12.5 MHz
				MASK		75	90		

(Continued)

# MB91350A Series

(Continued)

( $V_{CC} = 3.0\text{ V to }3.6\text{ V}$ ,  $V_{CC} = 2.7\text{ V to }3.6\text{ V}$  (MB91F356B/F357B only),  $V_{SS} = \text{DAVS} = \text{AV}_{SS} = 0\text{ V}$ ,  $T_a = -40\text{ }^\circ\text{C to }+85\text{ }^\circ\text{C}$ )

Parameter	Symbol	Pin name	Conditions	Value			Unit	Remarks
				Min	Typ	Max		
Power supply current	$I_{CC}$	$V_{CC}$	$f_c = 12.5\text{ MHz}$ , $V_{CC} = 3.3\text{ V}$	—	160	220	mA	MB91F355A/ F356B/F357B/ 355A/354A Multiply by 4RUN When operating at CLKB : 50 MHz CLKT : 25 MHz CLKP : 25 MHz
	$I_{CCS}$							100
	$I_{CCH}$		$T_a = +25\text{ }^\circ\text{C}$ , $V_{CC} = 3.3\text{ V}$		1	100	$\mu\text{A}$	At stop
	$I_{CCL}$		$T_a = +25\text{ }^\circ\text{C}$ , $f_c = 32.768\text{ kHz}$ , $V_{CC} = 3.3\text{ V}$		0.3	3.0	mA	Sub RUN When operating at CLKB : 32.768 kHz CLKT : 32.768 kHz CLKP : 32.768 kHz
	$I_{CCLS}$				0.2	2.0		Sub-sleep When operating at CLKP : 32.768 kHz
	$I_{CCT}$				5	120	$\mu\text{A}$	When operating in watch mode (Main Off, STOP)
Input capacitance	$C_{IH}$	Other than $V_{CC}$ , $V_{SS}$ , $\text{AV}_{CC}$ , $\text{AV}_{SS}$ , DAVC, DAVS	—	—	5	15	pF	

# MB91350A Series

## 4. AC Characteristics

### (1) Clock Timing

( $V_{CC} = 3.0\text{ V to }3.6\text{ V}$ ,  $V_{CC} = 2.7\text{ V to }3.6\text{ V}$  (MB91F356B/F357B only) ,  
 $V_{SS} = \text{DAVS} = \text{AV}_{SS} = 0\text{ V}$ ,  $T_a = -40\text{ }^\circ\text{C to }+85\text{ }^\circ\text{C}$ )

Parameter	Symbol	Pin name	Conditions	Value			Unit	Remarks
				Min	Typ	Max		
Clock frequency	$f_c$	X0, X1	—	10	—	12.5	MHz	MAIN PLL (When operating at max internal frequency (50 MHz) = 12.5 MHz self-oscillation with $\times 4$ PLL)
Clock cycle time	$t_c$			80		100	ns	
Clock frequency	$f_c$			10		25	MHz	
Internal operating clock frequency	$f_{CP}$	—	When a minimum value of 12.5 MHz is input as the X0 clock frequency and x4 multiplication is set for the PLL of the oscillator circuit	3.13*	—	50	MHz	CPU
	$f_{CPP}$					25		Peripheral
	$f_{CPT}$							External bus
Internal operating clock cycle time	$t_{CP}$	—	When a minimum value of 12.5 MHz is input as the X0 clock frequency and x4 multiplication is set for the PLL of the oscillator circuit	20	—	320*	ns	CPU
	$t_{CPP}$							Peripheral
	$t_{CPT}$							External bus
Clock frequency	$f_c$	X0A, X1A	—	30	32.768	35	kHz	SUB self-oscillation
Clock cycle time	$t_c$			28.6	30.51	33.3		
Input clock pulse width	—	X0, X1	$P_{WH}/t_c$ $P_{WL}/t_c$	40	—	60	%	
Internal operating clock frequency	$f_{CP}$ , $f_{CPP}$ , $f_{CPT}$	—	When a standard value of 32.768 kHz is input as the X0A clock frequency	2*		32.768	kHz	
Internal operating clock cycle time	$t_{CP}$ , $t_{CPP}$ , $t_{CPT}$			30.51			500*	$\mu\text{s}$

\* : The values assume a gear cycle of 1/16.

#### • Conditions for measuring the clock timing ratings

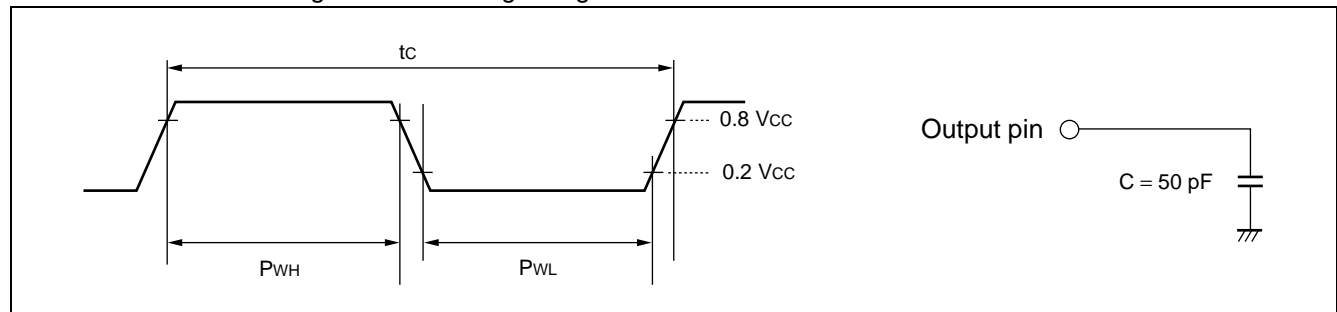

- Operation Guaranteed Range (Other than MB91F356B/F357B)

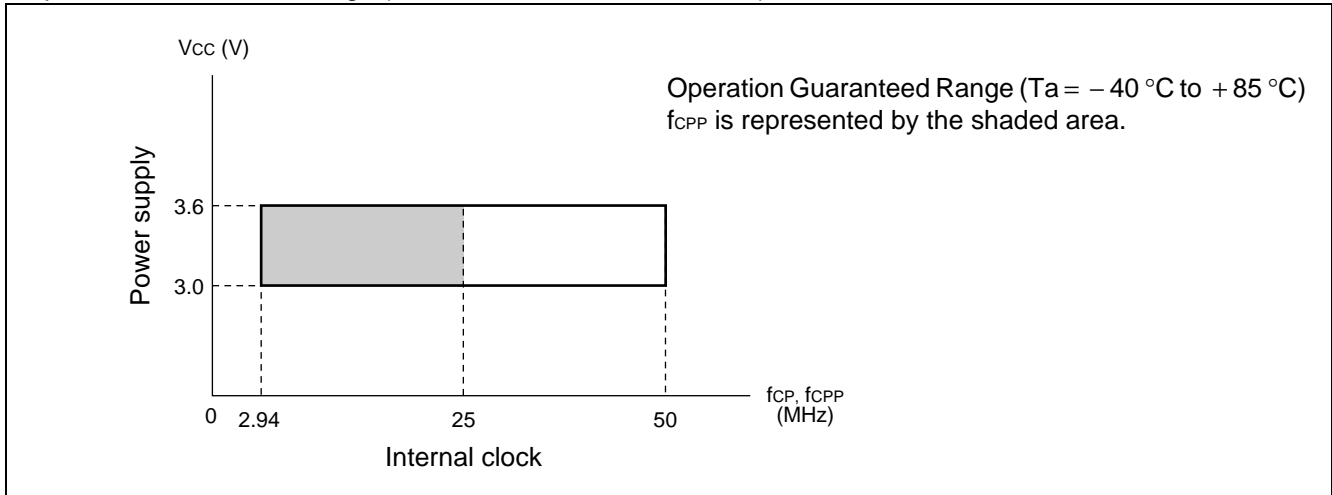

- External/internal clock setting range

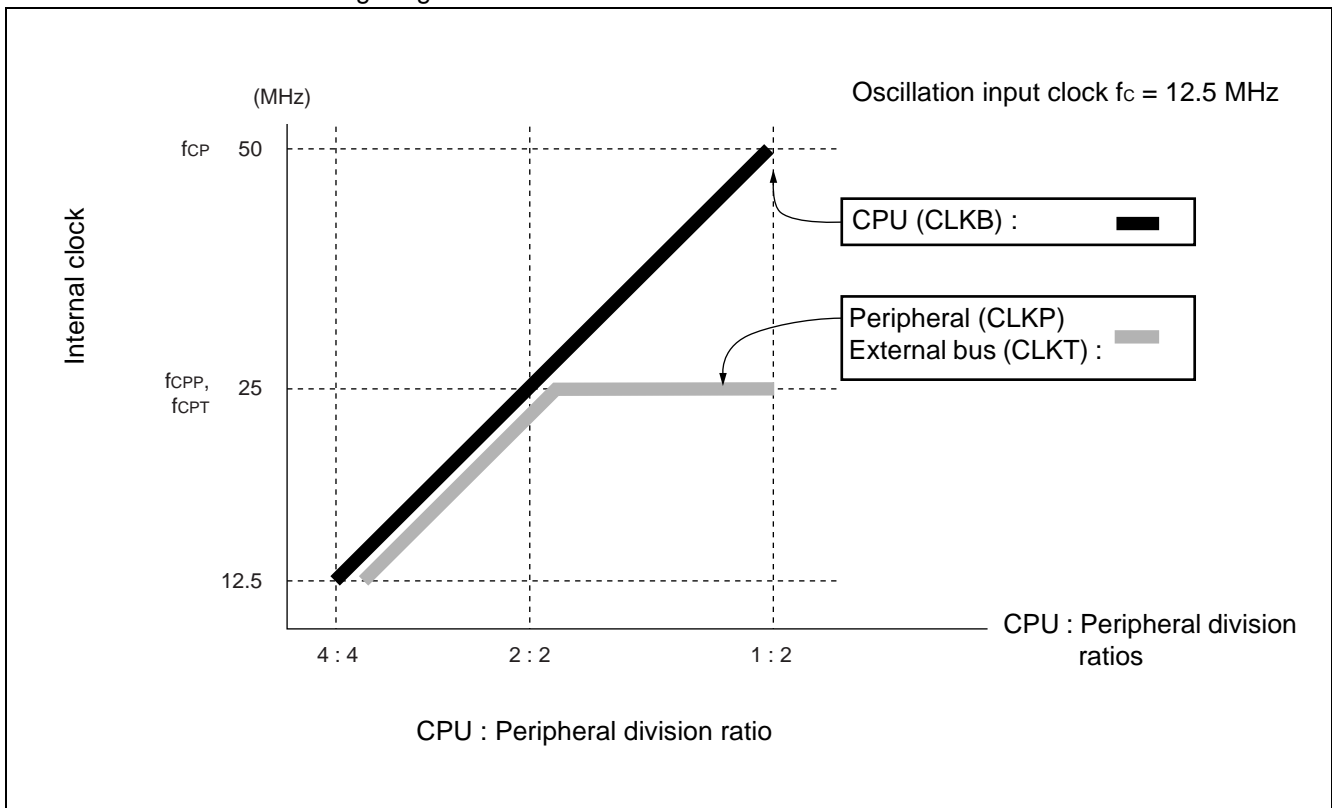

- Notes :
- When the PLL is used, the external clock input must fall between 10.0 MHz and 12.5 MHz.
  - Set the PLL oscillation stabilization wait time longer than 454.5  $\mu\text{s}$ .
  - The internal clock gear setting should not exceed the relevant value in the table in "(1) Clock timing ratings".

# MB91350A Series

- Operation Guaranteed Range (MB91F356B/F357B only)

For Flash memory wait of 2 (FLWC register : WTC[2 : 0] = 010)

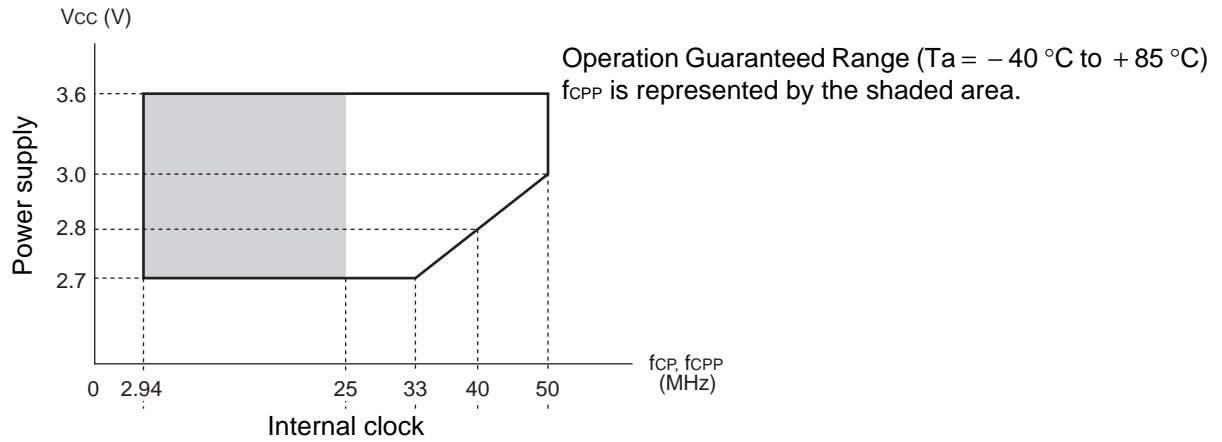

For Flash memory wait of 3 (FLWC register : WTC[2 : 0] = 011)

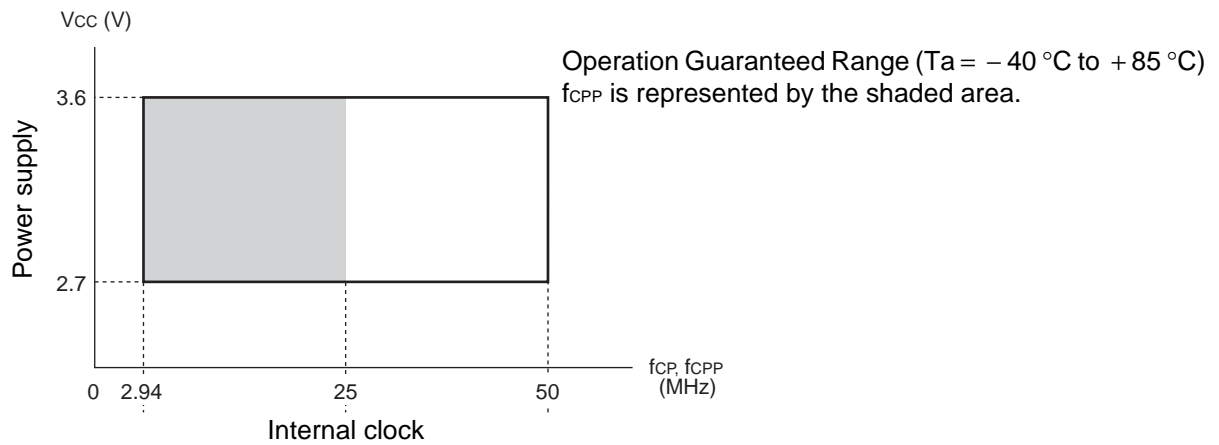

## (2) Clock Output Timing

( $V_{CC} = 3.0\text{ V to }3.6\text{ V}$ ,  $V_{CC} = 2.7\text{ V to }3.6\text{ V}$  (MB91F356B/F357B only) ,  
 $V_{SS} = \text{DAVS} = \text{AV}_{SS} = 0\text{ V}$ ,  $T_a = -40\text{ }^\circ\text{C to }85\text{ }^\circ\text{C}$ )

Parameter	Symbol	Pin name	Conditions	Value		Unit	Remarks
				Min	Max		
Cycle time	$t_{CYC}$	MCLK*4 SYSCLK	—	$t_{CPT}$	—	ns	*1
SYSCLK $\uparrow \rightarrow$ SYSCLK $\downarrow$	$t_{CHCL}$	MCLK*4 SYSCLK		$t_{CYC} - 5$	$t_{CYC} + 5$	ns	*2
SYSCLK $\downarrow \rightarrow$ SYSCLK $\uparrow$	$t_{CLCH}$	MCLK*4 SYSCLK		$t_{CYC} - 5$	$t_{CYC} + 5$	ns	*3

\*1 :  $t_{CYC}$  is the frequency of one clock cycle after gearing.

\*2 : This value is the rating when the gear ratio is set to  $\times 1$ . For the ratings when the gear ratio is set to 1/2, 1/4 or 1/8, substitute 1/2, 1/4 or 1/8 for n in the following equation.

$$(1/2 \times 1/n) \times t_{CYC} - 10$$

\*3 : This value is the rating when the gear ratio is set to  $\times 1$ .

\*4 : The MB91F353A/353A/352A/351A does not have MCLK pin.  
 In the following AC characteristics, MCLK is equal to SYSCLK.

Note :  $t_{CPT}$  represents the internal operating clock cycle time. Refer to “(1) Clock Timing”.

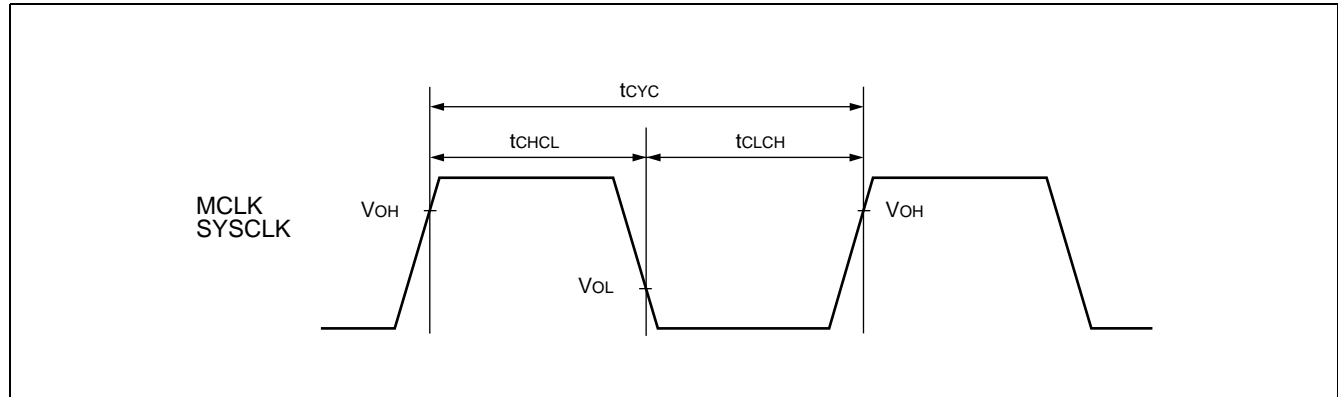

# MB91350A Series

## (3) Reset Ratings

( $V_{CC} = 3.0\text{ V to }3.6\text{ V}$ ,  $V_{CC} = 2.7\text{ V to }3.6\text{ V}$  (MB91F356B/F357B only) ,  
 $V_{SS} = DAVS = AV_{SS} = 0\text{ V}$ ,  $T_a = -40\text{ }^{\circ}\text{C to }+85\text{ }^{\circ}\text{C}$ )

Parameter	Symbol	Pin name	Conditions	Value		Unit
				Min	Max	
$\overline{\text{INIT}}$ input time (at power-on)	$t_{\text{INTL}}$	$\overline{\text{INIT}}$	—	$t_c \times 10$	—	ns
$\overline{\text{INIT}}$ input time (other than at power-on)				$t_c \times 10$		ns

Note :  $t_c$  represents the clock cycle time. Refer to “(1) Clock Timing”.

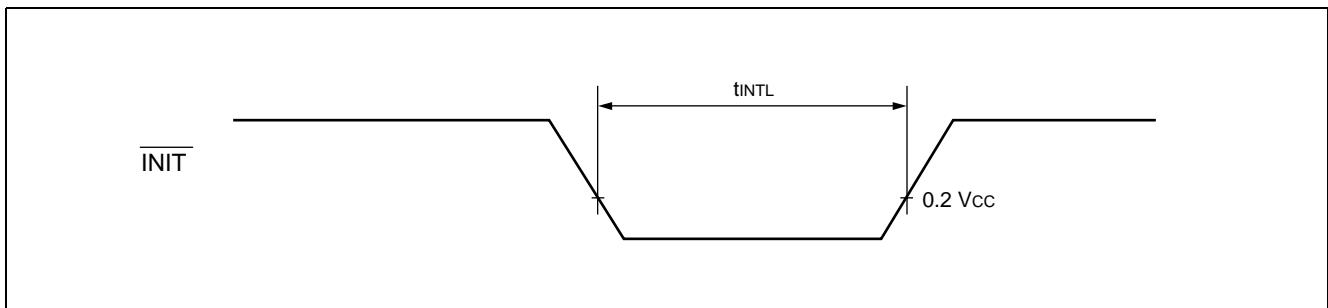

## (4) Normal Bus Access Read/Write Operation

• MB91F353A/353A/352A/351A

( $V_{CC} = 3.0\text{ V to }3.6\text{ V}$ ,  $V_{SS} = \text{DAVS} = \text{AV}_{SS} = 0\text{ V}$ ,  $T_a = -40\text{ }^\circ\text{C to }+85\text{ }^\circ\text{C}$ )

Parameter	Symbol	Pin name	Conditions	Value		Unit	Remarks
				Min	Max		
$\overline{\text{CS}}_0$ to $\overline{\text{CS}}_3$ setup	$t_{\text{CSLCH}}$	SYSCLK, $\overline{\text{CS}}_0$ to $\overline{\text{CS}}_3$	AWRxL : W02 = 0	3	—	ns	*3
	$t_{\text{CSDLCH}}$		AWR0L : W02 = 1	-3			
$\overline{\text{CS}}_0$ to $\overline{\text{CS}}_3$ hold	$t_{\text{CHCSH}}$				$t_{\text{CYC}} / 2 + 6$		
Address setup	$t_{\text{ASCH}}$	SYSCLK, A20 to A00*4	—	3	—	ns	
	$t_{\text{ASWL}}$	$\overline{\text{WR}}_0$ , $\overline{\text{WR}}_1$ , A20 to A00*4					
	$t_{\text{ASRL}}$	$\overline{\text{RD}}$ , A20 to A00*4					
Address hold	$t_{\text{CHAX}}$	SYSCLK, A20 to A00*4	—	3	$t_{\text{CYC}} / 2 + 6$	ns	
	$t_{\text{WHAX}}$	$\overline{\text{WR}}_0$ , $\overline{\text{WR}}_1$ , A20 to A00*4			—		
	$t_{\text{RHAX}}$	$\overline{\text{RD}}$ , A20 to A00*4			—		
Valid address → Valid data input time	$t_{\text{AVDV}}$	A20 to A00*4, D31 to D16	—	—	$3 / 2 \times t_{\text{CYC}} - 15$	ns	*1 *2
$\overline{\text{WR}}_0$ , $\overline{\text{WR}}_1$ delay time	$t_{\text{CHWL}}$	SYSCLK, $\overline{\text{WR}}_0$ , $\overline{\text{WR}}_1$			6		
$\overline{\text{WR}}_0$ , $\overline{\text{WR}}_1$ delay time	$t_{\text{CHWH}}$	$\overline{\text{WR}}_0$ , $\overline{\text{WR}}_1$	—	—	—	ns	
$\overline{\text{WR}}_0$ , $\overline{\text{WR}}_1$ minimum pulse width	$t_{\text{WLWH}}$	$\overline{\text{WR}}_0$ , $\overline{\text{WR}}_1$					
Data setup → $\overline{\text{WR}}_x \uparrow$	$t_{\text{DSWH}}$	$\overline{\text{WR}}_0$ , $\overline{\text{WR}}_1$ , D31 to D16	—	—	—	ns	
$\overline{\text{WR}}_x \uparrow$ → Data hold time	$t_{\text{WHDX}}$	D31 to D16					
$\overline{\text{RD}}$ delay time	$t_{\text{CHRL}}$	SYSCLK, $\overline{\text{RD}}$	—	—	6	ns	
$\overline{\text{RD}}$ delay time	$t_{\text{CHRH}}$						
$\overline{\text{RD}} \downarrow$ → Valid data input time	$t_{\text{RLDV}}$	$\overline{\text{RD}}$ , D31 to D16	—	—	$t_{\text{CYC}} - 10$	ns	*1
Data setup → $\overline{\text{RD}} \uparrow$ Time	$t_{\text{DSRH}}$				10		
$\overline{\text{RD}} \uparrow$ → Data hold time	$t_{\text{RHDX}}$	$\overline{\text{RD}}$	—	—	—	ns	
$\overline{\text{RD}}$ minimum pulse width	$t_{\text{RLRH}}$						
$\overline{\text{AS}}$ setup	$t_{\text{ASLCH}}$	SYSCLK, $\overline{\text{AS}}$	—	—	—	ns	
$\overline{\text{AS}}$ hold	$t_{\text{CHASH}}$						
					$t_{\text{CYC}} / 2 + 6$		

\*1 : When the bus timing is delayed by automatic wait insertion or RDY input, add the time ( $t_{\text{CYC}} \times$  the number of cycles added for the delay) to this rating.

\*2 : This value is the rating when the gear ratio is set to  $\times 1$ . For the ratings when the gear ratio is set to between 1/2 to 1/16, substitute 1/2 to 1/16 for n in the following equation.

Calculation expression :  $3 / (2n) \times t_{\text{CYC}} - 15$

\*3 : AWRxL : Area Wait Register

\*4 : The MB91F353A/353A/352A/351A does not have A23 to A21.

Note :  $t_{\text{CYC}}$  represents the cycle time. Refer to "(2) Clock Output Timing".

# MB91350A Series

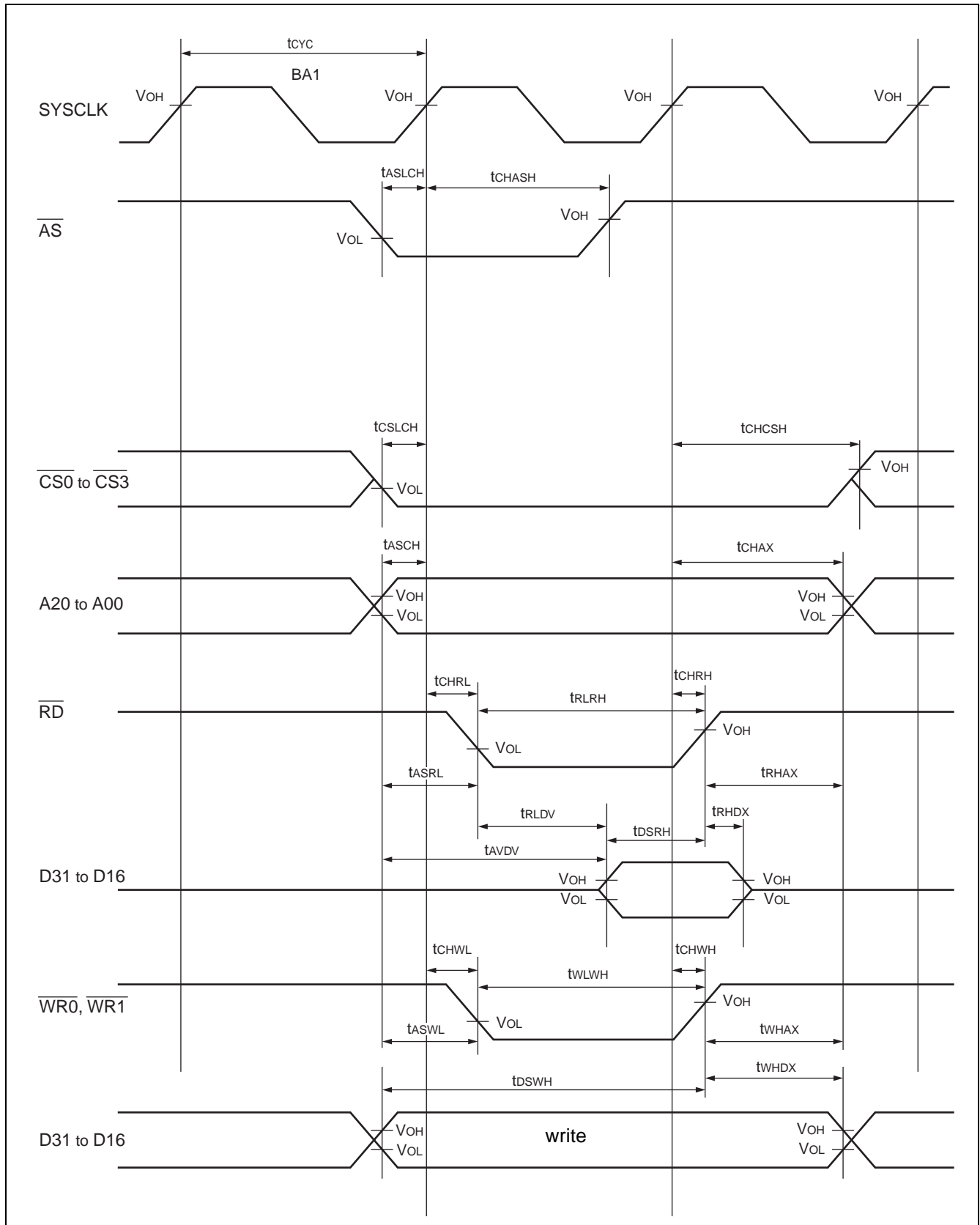

# MB91350A Series

- MB91F355A/F356B/F357B/355A/354A

( $V_{CC} = 3.0\text{ V to }3.6\text{ V}$ ,  $V_{CC} = 2.7\text{ V to }3.6\text{ V}$  (MB91F356B/F357B only),  
 $V_{SS} = \text{DAVS} = \text{AV}_{SS} = 0\text{ V}$ ,  $T_a = -40^\circ\text{C to }+85^\circ\text{C}$ )

Parameter	Symbol	Pin name	Conditions	Value		Unit	Remarks		
				Min	Max				
$\overline{\text{CS}}_0$ to $\overline{\text{CS}}_3$ setup	$t_{\text{CSLCH}}$	MCLK, $\overline{\text{CS}}_0$ to $\overline{\text{CS}}_3$	AWRxL*3 : W02 = 0	3	—	ns			
	$t_{\text{CSDLCH}}$		AWR0L : W02 = 1	-3	—	ns			
$\overline{\text{CS}}_0$ to $\overline{\text{CS}}_3$ hold	$t_{\text{CHCSH}}$			3	$t_{\text{CYC}}/2 + 6$	ns			
Address setup	$t_{\text{ASCH}}$	MCLK, A23 to A00*4	—	3	—	ns			
	$t_{\text{ASWL}}$	WR0, WR1, A23 to A00*4		3	—	ns			
	$t_{\text{ASRL}}$	$\overline{\text{RD}}$ , A23 to A00*4		3	—	ns			
Address hold	$t_{\text{CHAX}}$	MCLK, A23 to A00*4	—	3	$t_{\text{CYC}}/2 + 6$	ns			
	$t_{\text{WHAX}}$	WR0, WR1, A23 to A00*4		3	—	ns			
	$t_{\text{RHAX}}$	$\overline{\text{RD}}$ , A23 to A00*4		3	—	ns			
Valid address → Valid data input time	$t_{\text{AVDV}}$	A23 to A00*4, D31 to D16	—	—	$3/2 \times$ $t_{\text{CYC}} - 15$	ns	*1 *2		
WR0, WR1 delay time	$t_{\text{CHWL}}$	MCLK,		—	6	ns			
WR0, WR1 delay time	$t_{\text{CHWH}}$	WR0, WR1		—	6	ns			
WR0, WR1 minimum pulse width	$t_{\text{WLWH}}$	WR0, WR1		$t_{\text{CYC}} - 5$	—	ns			
Data setup → WRx ↑	$t_{\text{DSWH}}$	WR0, WR1,		$t_{\text{CYC}}$	—	ns			
WRx ↑ → Data hold time	$t_{\text{WHDX}}$	D31 to D16		3	—	ns			
RD delay time	$t_{\text{CHRL}}$	MCLK,		—	6	ns			
RD delay time	$t_{\text{CHRH}}$	RD		—	6	ns			
RD ↓ → Valid data input time	$t_{\text{RLDV}}$	$\overline{\text{RD}}$ , D31 to D16		$3.0\text{ V} \leq V_{CC} \leq 3.6\text{ V}$	—	$t_{\text{CYC}} - 10$	ns	*1	
Data setup → $\overline{\text{RD}}$ ↑ time	$t_{\text{DSRH}}$				10	—	ns		
RD ↓ → Data hold time	$t_{\text{RHDX}}$				$2.7\text{ V} \leq V_{CC} < 3.0\text{ V}$	15	—	ns	MB91F356B/ F357B only
					0	—	ns		
RD minimum pulse width	$t_{\text{RLRH}}$	$\overline{\text{RD}}$		$t_{\text{CYC}} - 5$	—	ns			
AS setup	$t_{\text{ASLCH}}$	MCLK,	—	3	—	ns			
AS hold	$t_{\text{CHASH}}$	AS		3	$t_{\text{CYC}}/2 + 6$	ns			

\*1 : When the bus timing is delayed by automatic wait insertion or RDY input, add the time ( $t_{\text{CYC}} \times$  the number of cycles added for the delay) to this rating.

\*2 : This value is the rating when the gear ratio is set to  $\times 1$ . For the ratings when the gear ratio is set to between 1/2 to 1/16, substitute 1/2 to 1/16 for n in the following equation.

Calculation expression :  $3/(2n) \times t_{\text{CYC}} - 15$

\*3 : AWRxL : Area Wait Register

\*4 : The MB91F353A/353A/352A/351A does not have A23 to A21.

Note :  $t_{\text{CYC}}$  represents the cycle time. Refer to "(2) Clock output timing".

# MB91350A Series

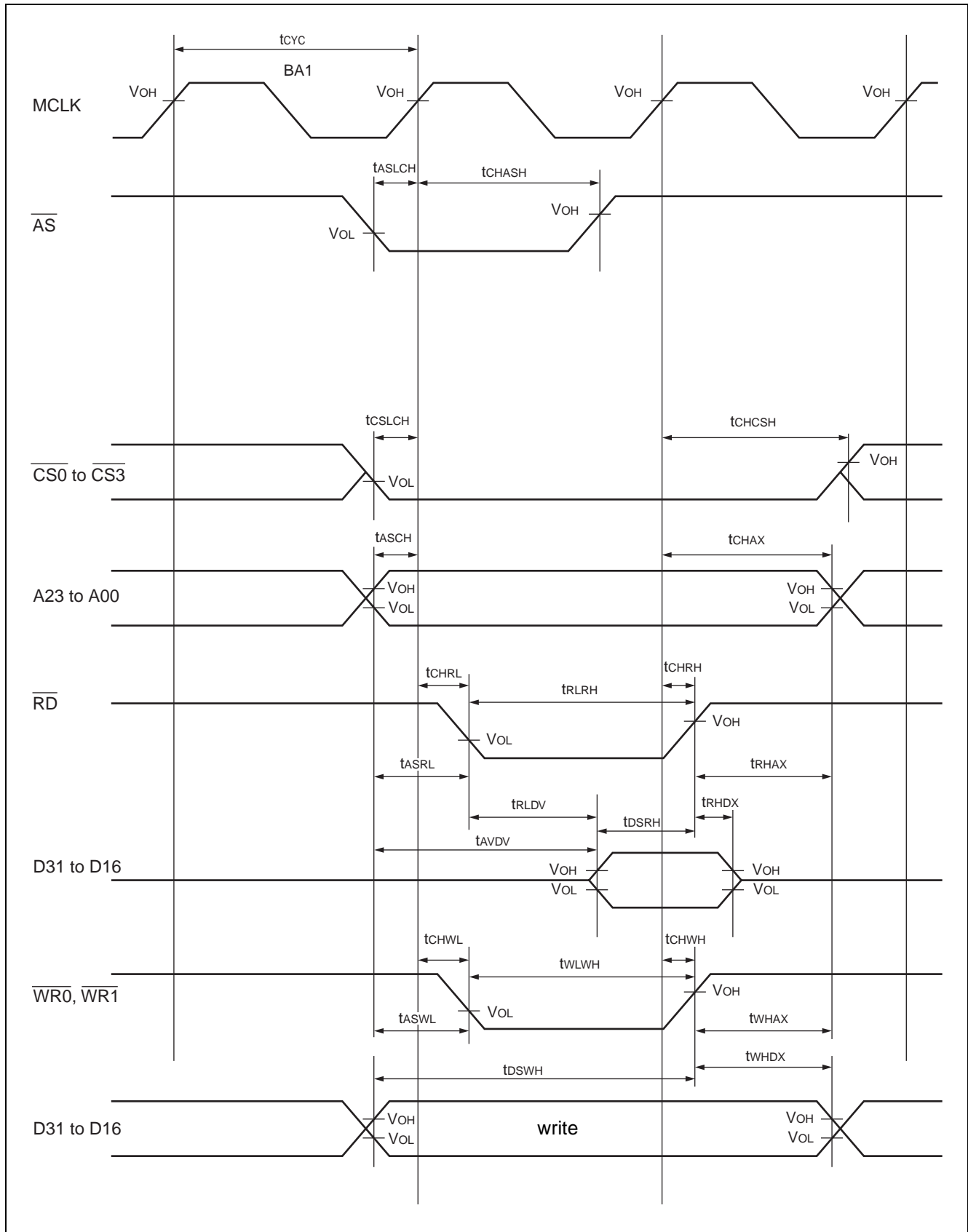

## (5) Multiplex Bus Access Read/Write Operation

( $V_{CC} = 3.0\text{ V to }3.6\text{ V}$ ,  $V_{CC} = 2.7\text{ V to }3.6\text{ V}$  (MB91F356B/F357B only) ,  
 $V_{SS} = \text{DAVS} = \text{AV}_{SS} = 0\text{ V}$ ,  $T_a = -40\text{ }^\circ\text{C to }+85\text{ }^\circ\text{C}$ )

Parameter	Symbol	Pin name	Conditions	Value		Unit
				Min	Max	
A15 to A00 Address AUDI setup time → SYSCLK ↑	$t_{ASCH}$	SYSCLK, D31 to D16	—	3	—	ns
SYSCLK ↑ → A15 to A00 Address AUDI hold time	$t_{CHAX}$			3	$t_{CYC}/2 + 6$	ns
A15 to A00 Address AUDI setup time → $\overline{AS}$ ↑	$t_{ASASH}$	SYSCLK, D31 to D16		12	—	ns
$\overline{AS}$ ↑ → A15 to A00 Address AUDI hold time	$t_{ASHAX}$			$t_{CYC} - 3$	$t_{CYC} + 3$	ns

- Notes :
- This rating is not guaranteed when the CS →  $\overline{RD}/\overline{WR}$  Setup Delay setting by AWR : bit1 is "0".
  - Beside this rating, normal bus interface ratings are applicable.
  - $t_{CYC}$  represents the cycle time. Refer to "(2) Clock Output Timing".

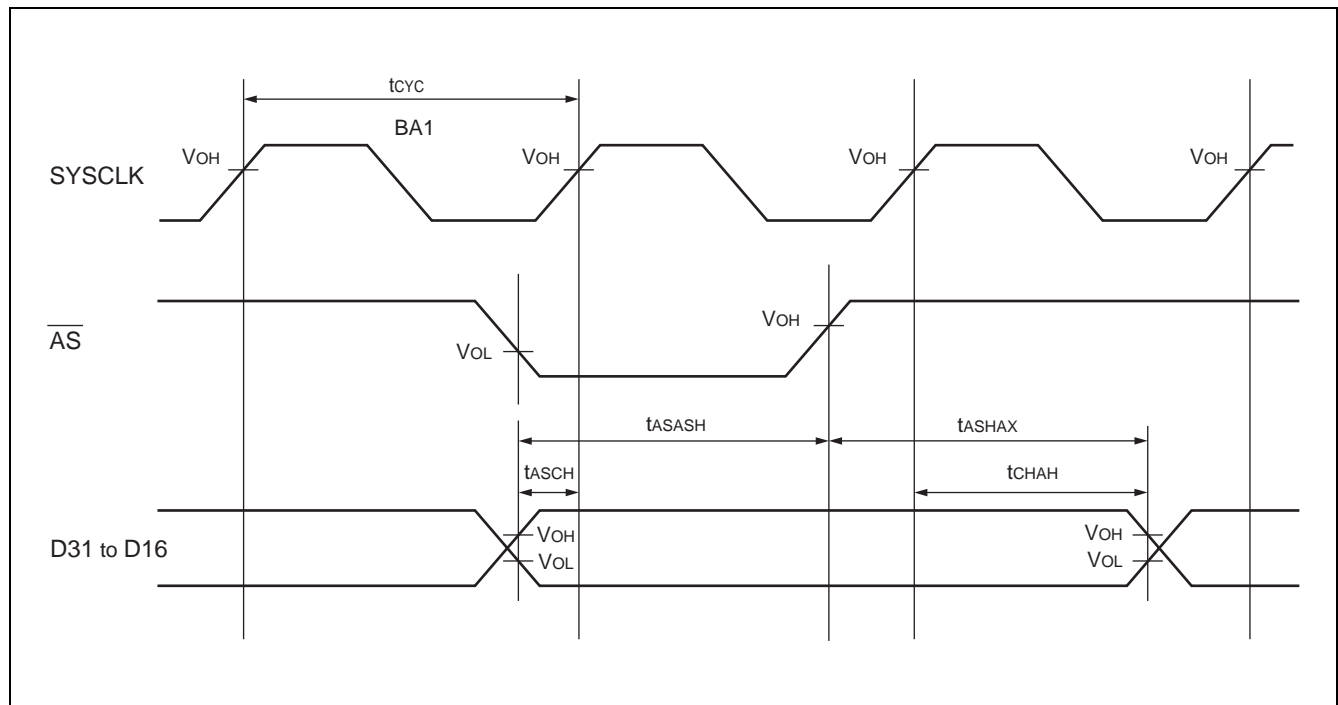

# MB91350A Series

## (6) Ready Input Timings

( $V_{CC} = 3.0\text{ V to }3.6\text{ V}$ ,  $V_{CC} = 2.7\text{ V to }3.6\text{ V}$  (MB91F356B/F357B only) ,  
 $V_{SS} = \text{DAVS} = \text{AV}_{SS} = 0\text{ V}$ ,  $T_a = -40\text{ }^\circ\text{C to }+85\text{ }^\circ\text{C}$ )

Parameter	Symbol	Pin name	Conditions	Value		Unit
				Min	Max	
RDY setup time → SYSCLK	$t_{RDYS}$	SYSCLK, RDY	—	15	—	ns
SYSCLK ↑ → RDY hold time	$t_{RDYH}$	SYSCLK, RDY	—	0	—	ns

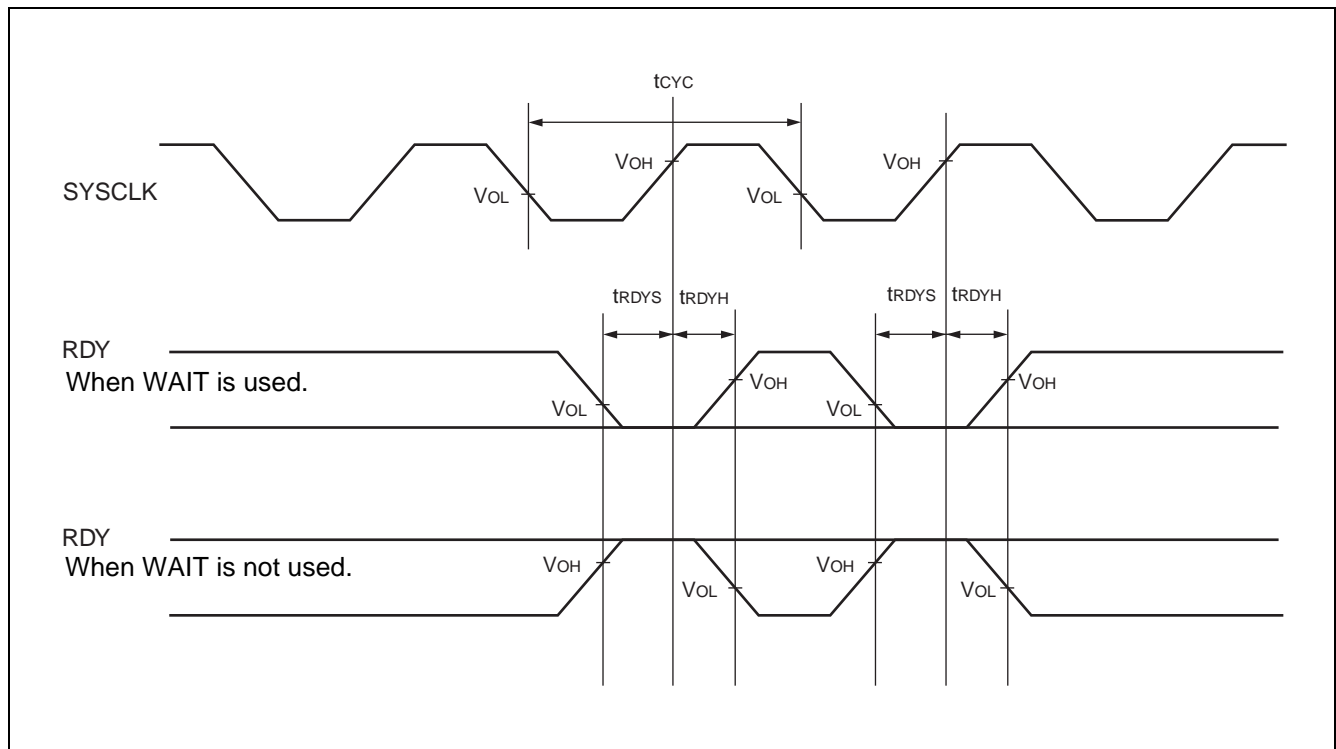

## (7) Hold Timing

( $V_{CC} = 3.0\text{ V to }3.6\text{ V}$ ,  $V_{CC} = 2.7\text{ V to }3.6\text{ V}$  (MB91F356B/F357B only) ,  
 $V_{SS} = \text{DAVS} = \text{AV}_{SS} = 0\text{ V}$ ,  $T_a = -40\text{ }^\circ\text{C to }+85\text{ }^\circ\text{C}$ )

Parameter	Symbol	Pin name	Conditions	Value		Unit
				Min	Max	
BRQ setup time → SYSCLK ↑	$t_{BRQS}$	SYSCLK, BRQ	—	15	—	ns
SYSCLK ↑ → BRQ hold time	$t_{BRQH}$			0	—	ns
$\overline{\text{BGRNT}}$ delay time	$t_{CHBGL}$	SYSCLK, $\overline{\text{BGRNT}}$	—	$t_{CYC} / 2 - 6$	$t_{CYC} / 2 + 6$	ns
$\overline{\text{BGRNT}}$ delay time	$t_{CHBGH}$			$t_{CYC} / 2 - 6$	$t_{CYC} / 2 + 6$	ns
Pin floating → $\overline{\text{BGRNT}}$ fall time	$t_{XZBGL}$	$\overline{\text{BGRNT}}$ , D31 to D16, A23 to A00, CS3 to CS0*	—	$t_{CYC} - 10$	$t_{CYC} + 10$	ns
$\overline{\text{BGRNT}}$ ↑ → Pin valid time	$t_{BGHXV}$			$t_{CYC} - 10$	$t_{CYC} + 10$	ns

\* : These only apply in the case where the SREN bit of the area select register (ACR) is set to "1".

Notes : • It takes 1 cycle or more from when BRQ is captured until  $\overline{\text{BGRNT}}$  changes.  
 •  $t_{CYC}$  represents the cycle time. Refer to "(2) Clock Output Timing".

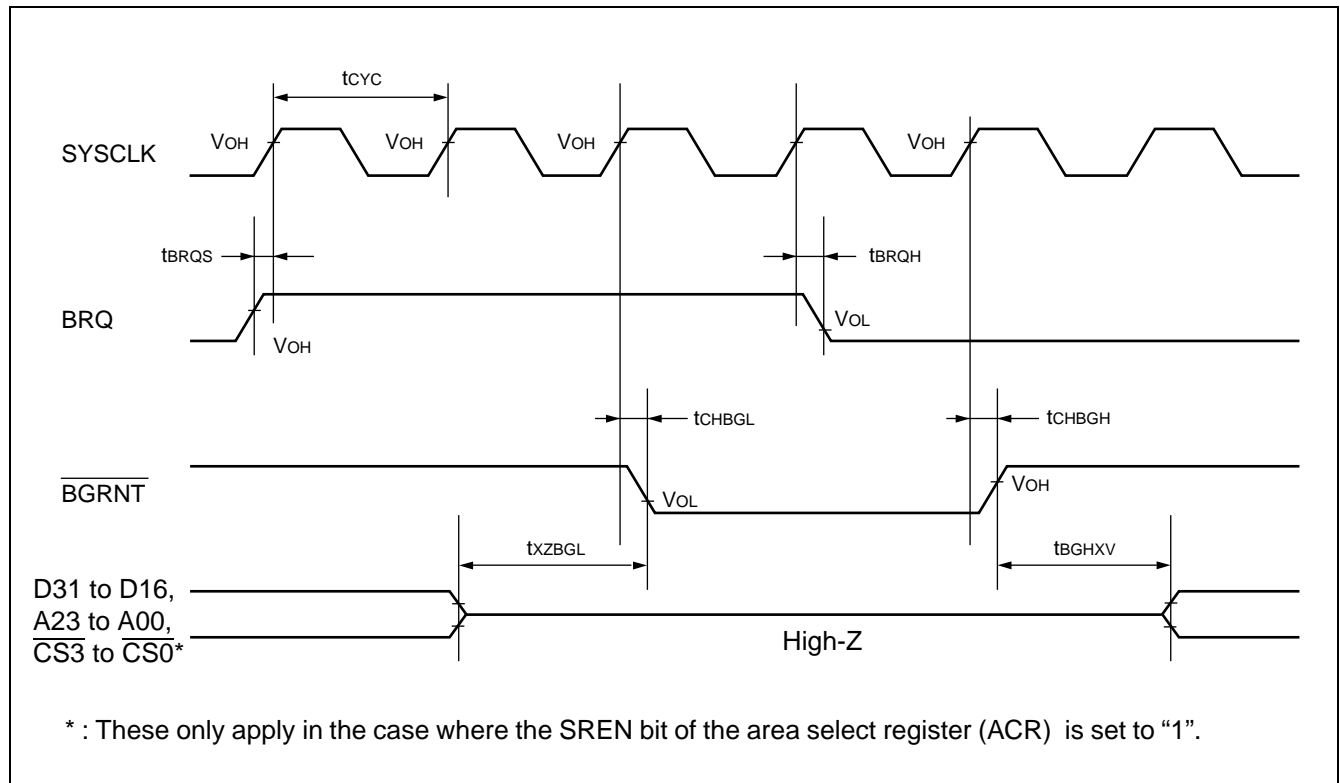

# MB91350A Series

## (8) UART, SIO Timing

( $V_{CC} = 3.0\text{ V to }3.6\text{ V}$ ,  $V_{CC} = 2.7\text{ V to }3.6\text{ V}$  (MB91F356B/F357B only) ,  
 $V_{SS} = \text{DAVS} = \text{AV}_{SS} = 0\text{ V}$ ,  $T_a = -40\text{ }^\circ\text{C to }+85\text{ }^\circ\text{C}$ )

Parameter	Sym- bol	Pin name	Conditions	Value		Unit	Remarks	
				Min	Max			
Serial clock Cycle time	t <sub>SCYC</sub>	SCK0 to SCK3, SCK6, SCK7	Internal shift lock mode	8 t <sub>CPP</sub>	—	ns	MB91F353A/353A/ 352A/351A	
		SCK0 to SCK7					MB91F355A/F356B/ F357B/355A/354A	
SCK ↓ → SO delay time	t <sub>SLOV</sub>	SCK0 to SCK3, SCK6, SCK7, SO0 to SO3, SO6, SO7		- 80	+ 80		MB91F353A/353A/ 352A/351A	
		SCK0 to SCK7, SO0 to SO7					MB91F355A/F356B/ F357B/355A/354A	
Valid SI → SCK ↑	t <sub>IVSH</sub>	SCK0 to SCK3, SCK6, SCK7, SI0 to SI3, SI6, SI7		100			MB91F353A/353A/ 352A/351A	
		SCK0 to SCK7, SI0 to SI7					MB91F355A/F356B/ F357B/355A/354A	
SCK ↑ → valid SIN hold time	t <sub>SHIX</sub>	SCK0 to SCK3, SCK6, SCK7, SI0 to SI3, SI6, SI7		60	—		MB91F353A/353A/ 352A/351A	
		SCK0 to SCK7, SI4, SI5					MB91F355A/F356B/ F357B/355A/354A	
serial clock “H” pulse width	t <sub>SHSL</sub>	SCK0 to SCK3, SCK6, SCK7		External shift clock mode	4 t <sub>CPP</sub>			MB91F353A/353A/ 352A/351A
		SCK0 to SCK7						MB91F355A/F356B/ F357B/355A/354A
serial clock “L” pulse width	t <sub>LSLH</sub>	SCK0 to SCK3, SCK6, SCK7	60		—	MB91F353A/353A/ 352A/351A		
		SCK0 to SCK7				MB91F355A/F356B/ F357B/355A/354A		
SCK ↓ → SO delay time	t <sub>SLOV</sub>	SCK0 to SCK3, SCK6, SCK7, SO0 to SO3, SO6, SO7	—		150	MB91F353A/353A/ 352A/351A		
		SCK0 to SCK7, SO0 to SO7				MB91F355A/F356B/ F357B/355A/354A		
Valid SI → SCK ↑	t <sub>IVSH</sub>	SCK0 to SCK3, SCK6, SCK7, SI0 to SI3, SI6, SI7	60		—	MB91F353A/353A/ 352A/351A		
		SCK0 to SCK7, SI0 to SI7				MB91F355A/F356B/ F357B/355A/354A		
SCK ↑ → valid SIN hold time	t <sub>SHIX</sub>	SCK0 to SCK3, SCK6, SCK7, SI0 to SI3, SI6, SI7	60		—	MB91F353A/353A/ 352A/351A		
		SCK0 to SCK7, SI0 to SI7				MB91F355A/F356B/ F357B/355A/354A		

Notes : • Above rating is for CLK synchronous mode.

• t<sub>CPP</sub> represents the peripheral clock cycle time. Refer to “(1) Clock Timing”.

• Internal shift clock mode

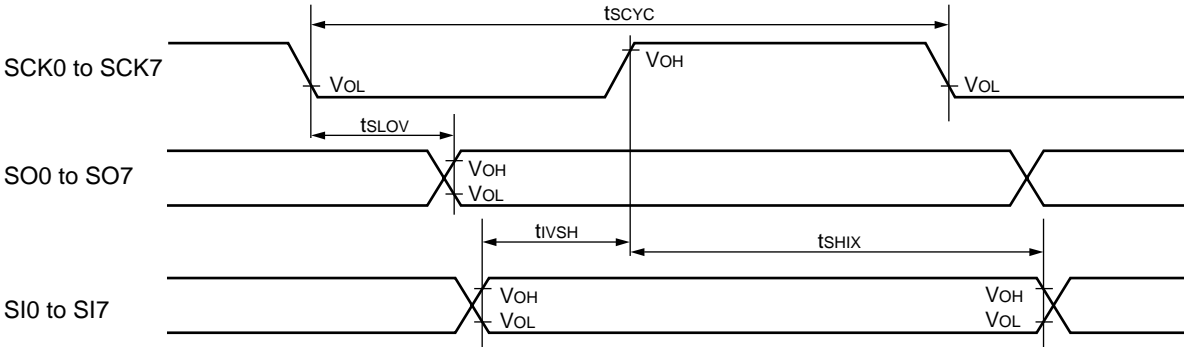

• External shift clock mode

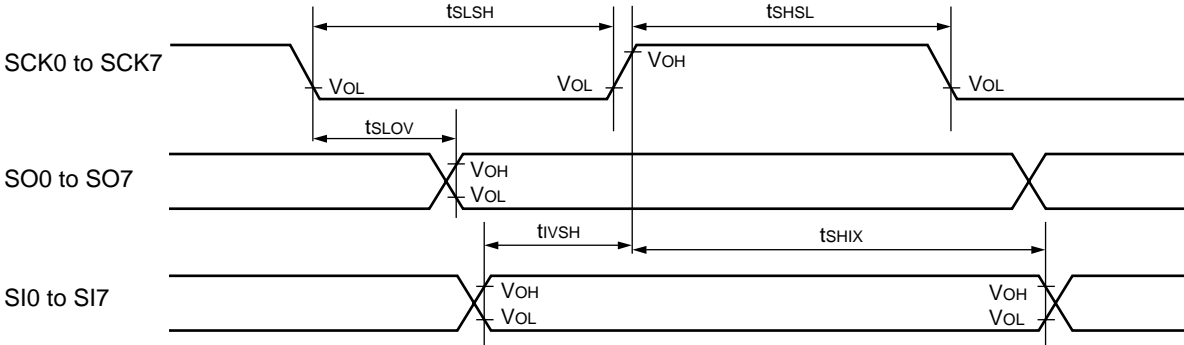

# MB91350A Series

## (9) Free-run timer Clock, PPG Timer Input Timing

( $V_{CC} = 3.0\text{ V to }3.6\text{ V}$ ,  $V_{CC} = 2.7\text{ V to }3.6\text{ V}$  (MB91F356B/F357B only) ,  
 $V_{SS} = DAVS = AV_{SS} = 0\text{ V}$ ,  $T_a = -40\text{ }^{\circ}\text{C to }+85\text{ }^{\circ}\text{C}$ )

Parameter	Symbol	Pin name	Conditions	Value		Unit	Remarks
				Min	Max		
Input pulse width	$t_{TIWH}$ $t_{TIWL}$	FRCK, TRG0 to TRG4, AIN0, BIN0, ZIN0	—	$2 t_{CPP}$	—	ns	MB91F353A/353A/ 352A/351A
		FRCK, TRG0 to TRG5, AIN0, AIN1, BIN0, BIN1, ZIN0, ZIN1					MB91F355A/F356B/ F357B/355A/354A

Note :  $t_{CPP}$  represents the peripheral clock cycle time. Refer to “(1) Clock Timing”.

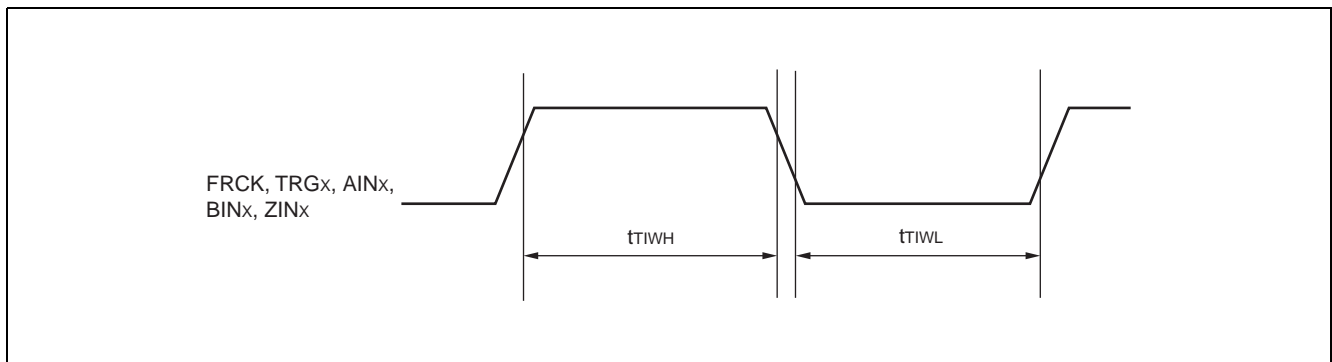

## (10) Trigger Input Timing

( $V_{CC} = 3.0\text{ V to }3.6\text{ V}$ ,  $V_{CC} = 2.7\text{ V to }3.6\text{ V}$  (MB91F356B/F357B only) ,  
 $V_{SS} = DAVS = AV_{SS} = 0\text{ V}$ ,  $T_a = -40\text{ }^{\circ}\text{C to }+85\text{ }^{\circ}\text{C}$ )

Parameter	Symbol	Pin name	Conditions	Value		Unit
				Min	Max	
A/D activation trigger input time	$t_{ATGX}$	$\overline{ATG}$	—	$5 t_{CPP}$	—	ns
Input capture input trigger	$t_{INP}$	IN0 to IN3	—	$5 t_{CPP}$	—	ns

Note :  $t_{CPP}$  represents the peripheral clock cycle time. Refer to “(1) Clock Timing”.

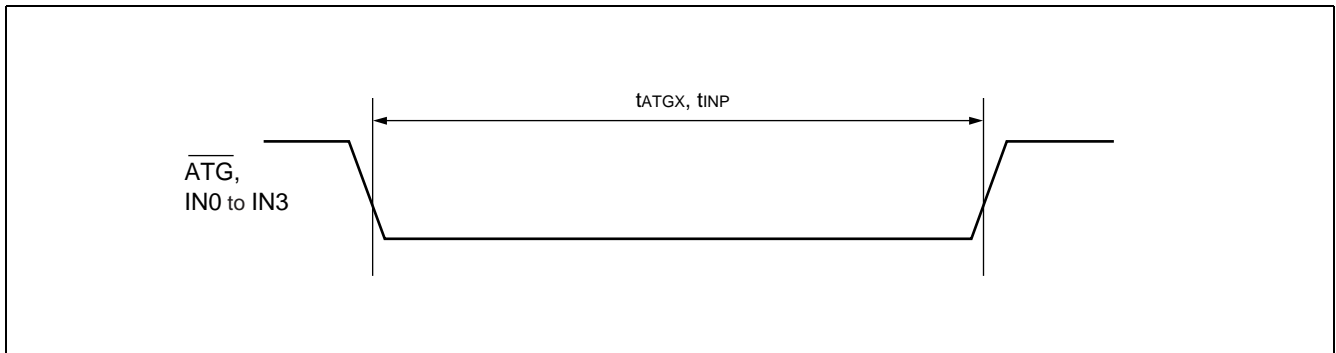

# MB91350A Series

## (11)DMA controller timing\*1

### • For edge detection (block/step transfer mode, burst transfer mode)

( $V_{CC} = 3.0\text{ V to }3.6\text{ V}$ ,  $V_{CC} = 2.7\text{ V to }3.6\text{ V}$  (MB91F356B/F357B only) ,  
 $V_{SS} = \text{DAVS} = \text{AV}_{SS} = 0\text{ V}$ ,  $T_a = -40^\circ\text{C to }+85^\circ\text{C}$ )

Parameter	Symbol	Pin name	Conditions	Value		Unit
				Min	Max	
DREQ Input pulse width	$t_{DRWL}$	DREQ0 to DREQ2	—	$2 t_{CYC}^{*2}$	—	ns
DREQ Input pulse width	$t_{DSWH}$	DSTP0 to DSTP2		$2 t_{CYC}^{*2}$	—	ns

\*1 : The MB91F353A/353A/352A/351A does not have this standard.

\*2 :  $t_{CYC}$  becomes  $t_{CP}$  when  $f_{CPT}$  is greater than  $f_{CR}$ .

### • For level detection (demand transfer mode)

( $V_{CC} = 3.0\text{ V to }3.6\text{ V}$ ,  $V_{CC} = 2.7\text{ V to }3.6\text{ V}$  (MB91F356B/F357B only) ,  
 $V_{SS} = \text{DAVS} = \text{AV}_{SS} = 0\text{ V}$ ,  $T_a = -40^\circ\text{C to }+85^\circ\text{C}$ )

Parameter	Symbol	Pin name	Conditions	Value		Unit
				Min	Max	
DREQ setup time	$t_{DRS}$	MCLK, DREQ0 to DREQ2	—	15	—	ns
DREQ hold time	$t_{DRH}$	MCLK, DREQ0 to DREQ2		0.0	—	ns
DSTP setup time	$t_{DSTPS}$	MCLK, DSTP0 to DSTP2		15	—	ns
DSTP hold time	$t_{DSTPH}$	MCLK, DSTP0 to DSTP2		0.0	—	ns

• Common operation mode

( $V_{CC} = 3.0\text{ V to }3.6\text{ V}$ ,  $V_{CC} = 2.7\text{ V to }3.6\text{ V}$  (MB91F356B/F357B only),  
 $V_{SS} = \text{DAVS} = \text{AV}_{SS} = 0\text{ V}$ ,  $T_a = -40^\circ\text{C to }+85^\circ\text{C}$ )

Parameter	Symbol	Pin name	Conditions	Value		Unit	Remarks
				Min	Max		
DACK delay time	$t_{DALCH}$	MCLK, DACK0 to DACK2	AWRxL* : W02 = 0	3	—	ns	CS timing
				—	6	ns	FR30 compatible
	$t_{DADLCH}$		AWR0L : W02 = 1	-3	—	ns	CS timing
				—	6	ns	FR30 compatible
	$t_{CHDAH}$		—	—	$t_{CYC}/2 + 6$	ns	CS timing
				—	6	ns	FR30 compatible
DEOP delay time	$t_{DELCH}$	MCLK, DEOP0 to DEOP2	AWR0L : W02 = 0	3	—	ns	CS timing
				—	6	ns	FR30 compatible
	$t_{DEDLCH}$		AWRxL* : W02 = 1	-3	—	ns	CS timing
				—	6	ns	FR30 compatible
	$t_{CHDEH}$		—	—	$t_{CYC}/2 + 6$	ns	CS timing
				—	6	ns	FR30 compatible
$\overline{\text{IORD}}$ delay time	$t_{CHIRL}$	MCLK, $\overline{\text{IORD}}$	—	—	6	ns	
	$t_{CHIRH}$			—	6	ns	
$\overline{\text{IOWR}}$ delay time	$t_{CHIWL}$	MCLK, $\overline{\text{IOWR}}$		—	6	ns	
	$t_{CHIWH}$			—	6	ns	
$\overline{\text{IORD}}$ minimum pulse width	$t_{IRLIRH}$	$\overline{\text{IORD}}$		12	—	ns	
$\overline{\text{IOWR}}$ minimum pulse width	$t_{IWLIIWH}$	$\overline{\text{IOWR}}$		12	—	ns	

\* : AWRxL : Area Wait Register.

Note :  $t_{CYC}$  represents the cycle time. Refer to “(2) Clock output timing”.

# MB91350A Series

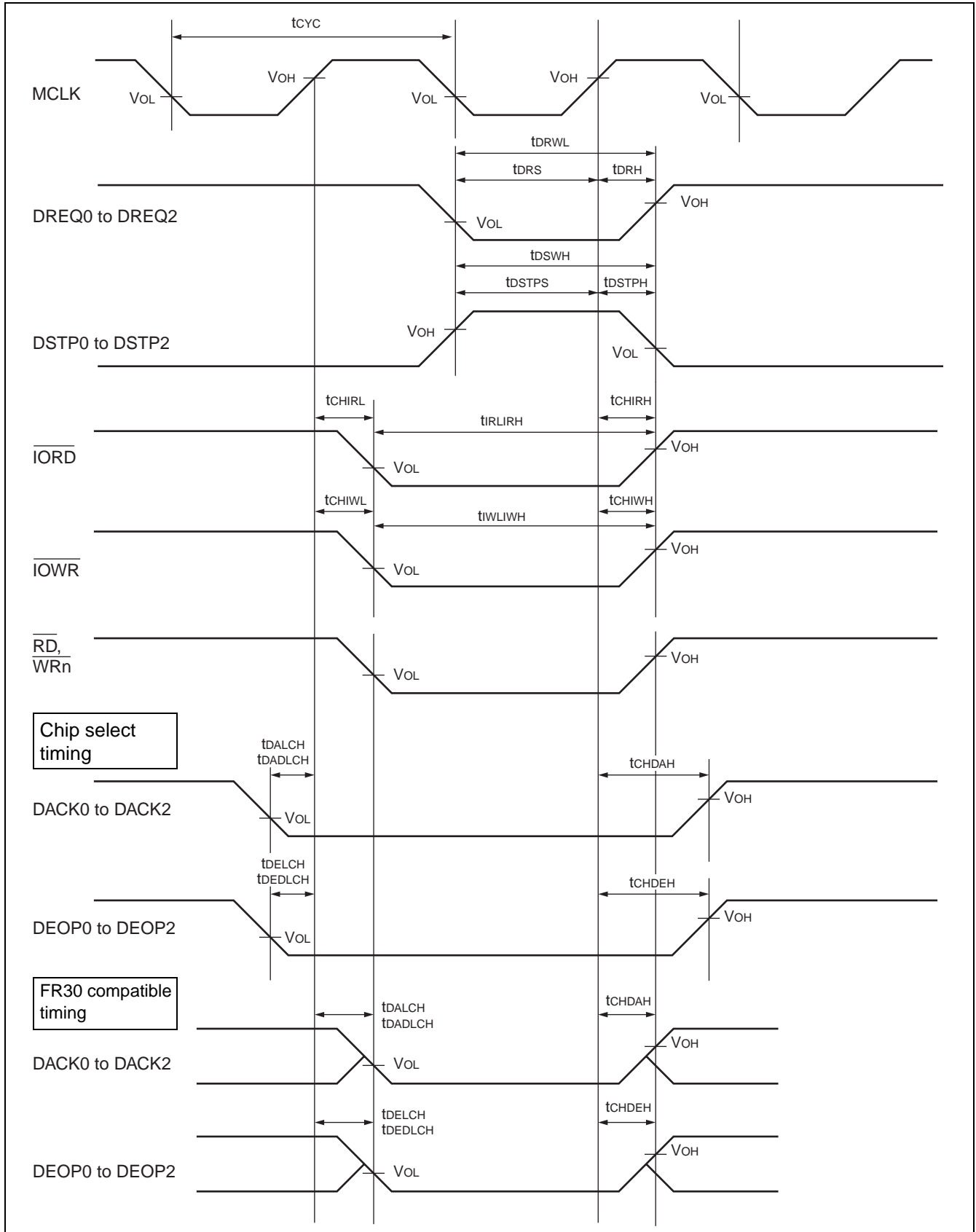

## (12) I<sup>2</sup>C Timing

( $V_{CC} = 3.0\text{ V to }3.6\text{ V}$ ,  $V_{CC} = 2.7\text{ V to }3.6\text{ V}$  (MB91F356B/F357B only) ,  
 $V_{SS} = \text{DAVS} = \text{AV}_{SS} = 0\text{ V}$ ,  $T_a = -40\text{ }^\circ\text{C to }+85\text{ }^\circ\text{C}$ )

Parameter	Symbol	Condition	Standard-mode		Fast-mode*4		Unit
			Min	Max	Min	Max	
SCL clock frequency	$f_{SCL}$		0	100	0	400	kHz
Hold time (repeated) START condition SDA↓→SCL↓	$t_{HDSTA}$	R = 1.0 kΩ, C = 50 pF*1	4.0	—	0.6	—	μs
"L" width of the SCL clock	$t_{LOW}$		4.7	—	1.3	—	μs
"H" width of the SCL clock	$t_{HIGH}$		4.0	—	0.6	—	μs
Set-up time for a repeated START condition SCL↑→SDA↓	$t_{SUSTA}$		4.7	—	0.6	—	μs
Data hold time SCL↓→SDA↓↑	$t_{HDDAT}$		0	3.45*2	0	0.9*3	μs
Data set-up time SDA↓↑→SCL↑	$t_{SUDAT}$		250	—	100	—	ns
Set-up time for STOP condition SCL↑→SDA↑	$t_{SUSTO}$		4.0	—	0.6	—	μs
Bus free time between a STOP and START condition	$t_{BUS}$		4.7	—	1.3	—	μs

\*1 : R,C : Pull-up resistance and load capacitance of the SCL and SDA lines.

\*2 : The maximum  $t_{HDDAT}$  only has to be met if the device does not extend the "L" width ( $t_{LOW}$ ) of the SCL signal.

\*3 : A Fast-mode I<sup>2</sup>C-bus device can be used in a Standard-mode I<sup>2</sup>C-bus system, but the requirement  $t_{SUDAT} \geq 250\text{ ns}$  must then be met.

\*4 : For use at over 100 kHz, set the machine clock to at least 6 MHz.

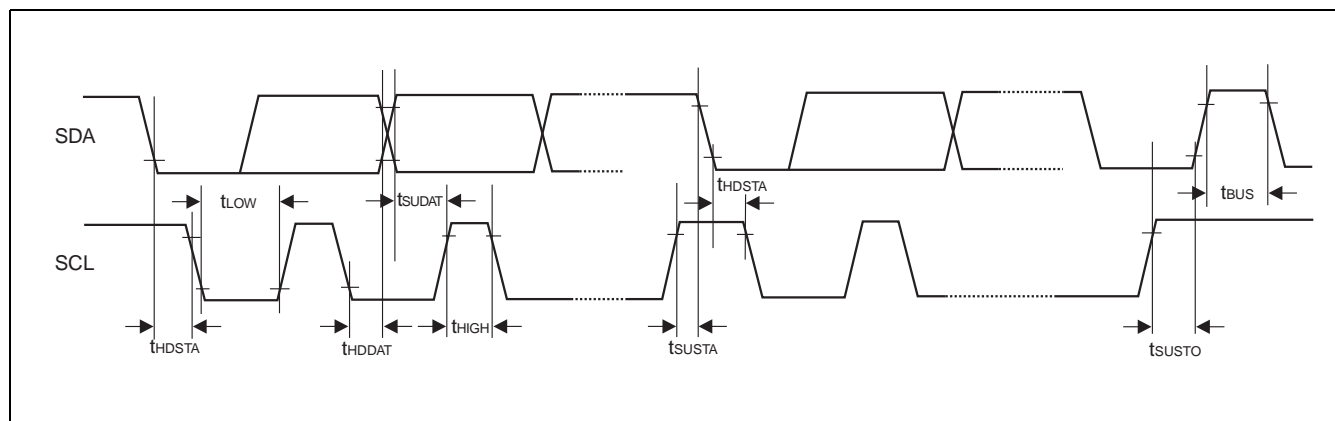

# MB91350A Series

## (13) External Interrupt Input Timing

( $V_{CC} = 3.0\text{ V to }3.6\text{ V}$ ,  $V_{CC} = 2.7\text{ V to }3.6\text{ V}$  (MB91F356B/F357B only),  
 $V_{SS} = \text{DAVS} = \text{AV}_{SS} = 0\text{ V}$ ,  $T_a = -40\text{ }^\circ\text{C to }+85\text{ }^\circ\text{C}$ )

Parameter	Symbol	Pin name	Condition	Standard-mode		Unit	Remark
				Min	Max		
Input pulse width	$t_{INTWH}$ $t_{INTWL}$	INT0 to INT7 $\overline{\text{NMI}}$	—	3 $t_{CYCP}$	—	ns	*1 MB91F353A/353A/352A/ 351A
				1.0	—	$\mu\text{s}$	*2 MB91F353A/353A/352A/ 351A
		INT0 to INT15 $\overline{\text{NMI}}$	—	3 $t_{CYCP}$	—	ns	*1 MB91F355A/F356B/F357B/ 355A/354A
				1.0	—	$\mu\text{s}$	*2 MB91F355A/F356B/F357B/ 355A/354A

\*1 :  $t_{CYCP}$  : The cycle time of peripheral clock (except STOP mode)

\*2 : At STOP mode

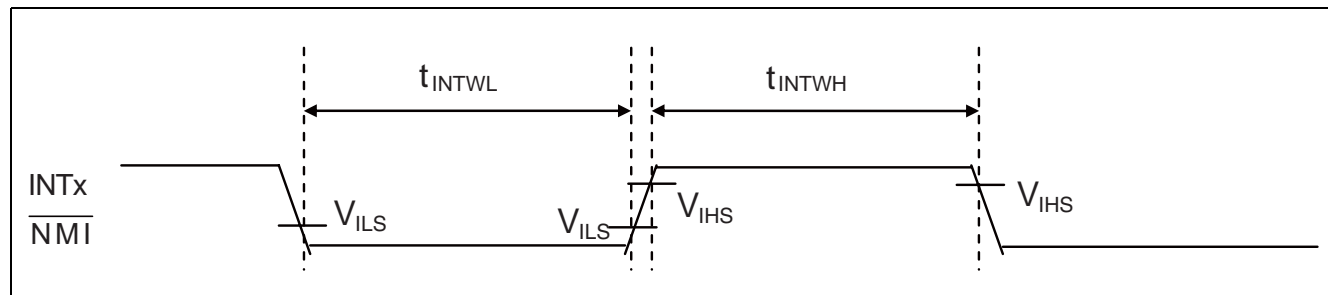

## 5. Electrical Characteristics for the A/D Converter

### • MB91F353A/353A/352A/351A

( $V_{CC} = AV_{CC} = 3.0\text{ V to }3.6\text{ V}$ ,  $AVRH = 3.0\text{ V to }3.6\text{ V}$ ,  $V_{SS} = DAVS = AV_{SS} = 0\text{ V}$ ,  $T_a = -40\text{ }^\circ\text{C to }+85\text{ }^\circ\text{C}$ )

Parameter	Symbol	Pin name	Value			Unit	Remarks
			Min	Typ	Max		
Resolution	—	—	—	—	10	bit	At $AV_{CC} = 3.3\text{ V}$ , $AVRH = 3.3\text{ V}$
Total error *1			- 5.0		+ 5.0		
Nonlinear error *1			- 3.5		+ 3.5		
Differential linear error *1			- 2.5		+ 2.5		
Zero transition voltage *1		AN7 to AN0	$AVRL - 2.0$	$AVRL + 1.0$	$AVRL + 6.0$		
Full-transition voltage *1			$AVRH - 5.5$	$AVRH + 1.5$	$AVRH + 3.0$		
Conversion time	—	—	1.48*2	—	300	$\mu\text{s}$	
Analog power supply current (analog + digital)	$I_A$	$AV_{CC}$	—	7	—	mA	At STOP
	$I_{AH}$			—	5		
Reference power supply current (between AVRH and AVRL)	$I_R$	AVRH		470	—	$\mu\text{A}$	At $AVRH = 3.0\text{ V}$ , $AVRL = 0.0\text{ V}$
	$I_{RH}$			—	10		
Analog input capacitance	—	AN7 to AN0		40	—	$\text{pF}$	
Interchannel disparity	—			—	4	LSB	

\*1 : Measured in the CPU sleep state

\*2 : When the peripheral resource clock frequency is 25.0 MHz, set the Conversion Time Setting Register (ADCT) to a value equal to or greater than 5334<sub>H</sub>.

Set each bit as follows :

Sampling time :  $SAMP3\text{ to }SAMP0 \geq 5H$

Conversion time a :  $CV03\text{ to }CV0 \geq 3H$

Conversion time b :  $CV13\text{ to }CV0 \geq 3H$

Conversion time c :  $CV23\text{ to }CV0 \geq 4H$

# MB91350A Series

## • MB91F355A/F356B/F357B/355A/354A/V350A

( $V_{CC} = AV_{CC} = 3.0\text{ V to }3.6\text{ V}$ ,  $AVRH = 3.0\text{ V to }3.6\text{ V}$ ,  $V_{SS} = DAVS = AV_{SS} = 0\text{ V}$ ,  $T_a = -40^{\circ}\text{C to }+85^{\circ}\text{C}$ )

Parameter	Symbol	Pin name	Value			Unit	Remarks	
			Min	Typ	Max			
Resolution	—	—	—	—	10	bit	AV <sub>CC</sub> = 3.3 V, AVRH = 3.3 V	
Total error*1			- 5.0		+ 5.0			
Nonlinear error*1			- 3.5		+ 3.5			
Differential linear error*1			- 2.5		+ 2.5			
Zero transition voltage*1			AN11 to AN0		AVRL - 2.0	AVRL + 1.0		AVRL + 6.0
Full-transition voltage*1					AVRH - 5.5	AVRH + 1.5		AVRH + 3.0
Conversion time			—		—	1.48*2		—
Analog power supply current (analog + digital)	I <sub>A</sub>	AV <sub>CC</sub>	—	8	—	mA		
	I <sub>AH</sub>			—	5	μA	At stop	
Reference power supply current (between AVRH and AVRL)	I <sub>R</sub>	AVRH		470	—			AVRH = 3.0 V, AVRL = 0.0 V
	I <sub>RH</sub>			—	10		At stop	
Analog input capacitance	—	AN11 to AN0		40	—	pF		
Interchannel disparity	—			—	4	LSB		

\*1 : Measured in the CPU sleep state

\*2 : When the peripheral resource clock frequency is 25.0 MHz, set the Conversion Time Setting Register (ADCT) to a value equal to or greater than 5334<sub>H</sub>.

Set each bit as follows :

- Sampling time : SAMP3 to SAMP0 ≥ 5<sub>H</sub>
- Conversion time a : CV03 to CV0 ≥ 3<sub>H</sub>
- Conversion time b : CV13 to CV0 ≥ 3<sub>H</sub>
- Conversion time c : CV23 to CV0 ≥ 4<sub>H</sub>

## • About the external impedance and sampling time of the analog input

- A/D converter with sample and hold circuit. If the external impedance is too high to ensure sufficient sampling time, the analog voltage of the internal sample and hold capacitor will not be sufficiently charged, adversely affecting the A/D conversion precision. Therefore, to satisfy the A/D conversion precision standard, consider the relationship between the external impedance and minimum sampling time and either adjust the resistor value and operating frequency or decrease the external impedance so that the sampling time is longer than the minimum value. Moreover, if sufficient sampling time cannot be ensured, connect a capacitor of about 0.1  $\mu\text{F}$  to the analog input pin.

### • Analog input circuit schematic

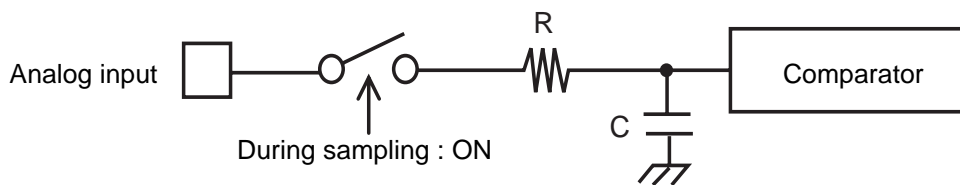

	R	C
MB91355A/354A/353A/352A/351A	0.18 k $\Omega$ (Max)	63.0 pF (Max)
MB91F355A/F353A/F356B/F357B	0.18 k $\Omega$ (Max)	39.0 pF (Max)

Note : The values are reference values.

### • The relationship between the external impedance and minimum sampling time

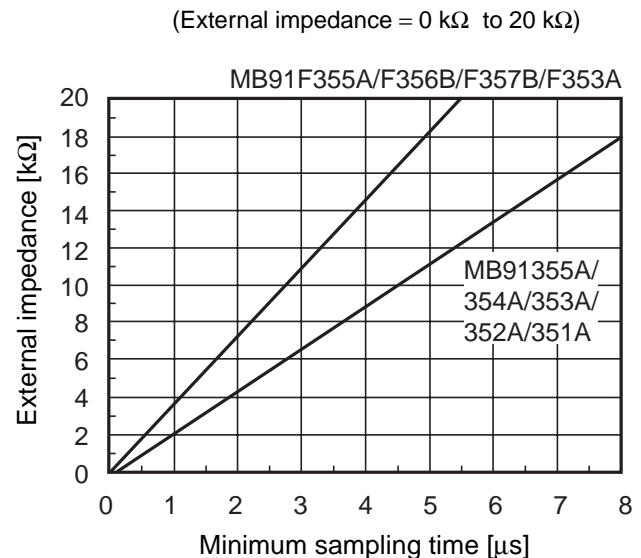
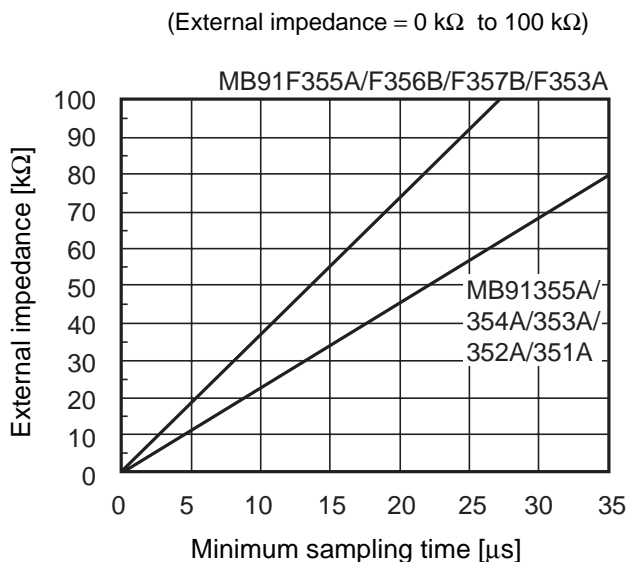

### • About errors

The smaller the value of  $|AVRH - AV_{SS}|$ , the greater the relative error.

# MB91350A Series

## Definition of A/D Converter Terms

- Resolution  
Analog variation that is recognized by an A/D converter.
- Linearity error  
The difference between the line connecting the zero transition point ( "00 0000 0000" ↔ "00 0000 0001" ) and the full-scale transition point ( "11 1111 1110" ↔ "11 1111 1111" ) and the actual conversion characteristics.
- Differential linear error  
Deviation from the ideal value of the input voltage that is required to change the output code by 1 LSB.

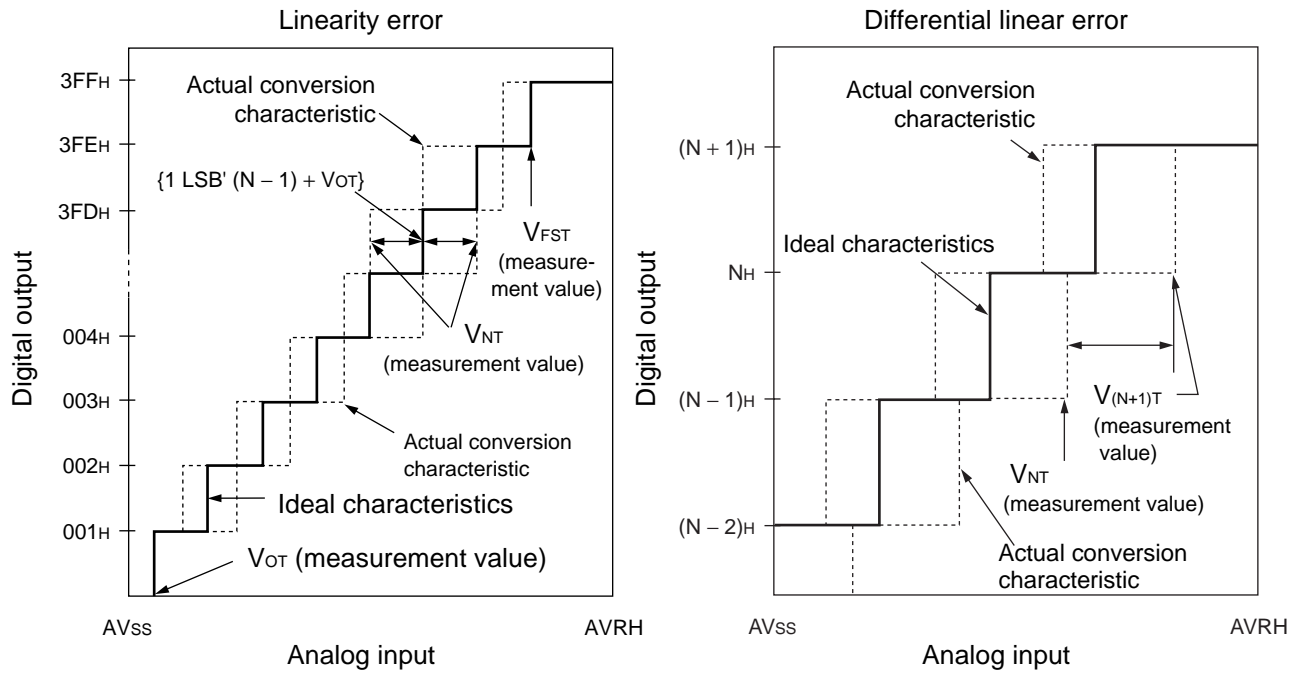

$$\text{Linear error in digital output } N = \frac{V_{NT} - \{1 \text{ LSB}' \times (N - 1) + V_{OT}\}}{1 \text{ LSB}' } \text{ [LSB]}$$

$$\text{Differential linear error in digital output } N = \frac{V_{(N+1)T} - V_{NT}}{1 \text{ LSB}' } - 1 \text{ [LSB]}$$

$$1 \text{ LSB} = \frac{V_{FST} - V_{OT}}{1022} \text{ [V]}$$

N : A/D converter digital output value

$V_{OT}$  : The voltage at which the digital output transitions from (000)<sub>H</sub> to (001)<sub>H</sub>

$V_{FST}$  : The voltage at which the digital output transitions from (3FE)<sub>H</sub> to (3FF)<sub>H</sub>

$V_{NT}$  : The voltage at which the digital output transitions from (N - 1)<sub>H</sub> to N<sub>H</sub>

- Total error

This error indicates the difference between the actual and ideal values, including the zero transition error/full-scale transition error/linearity error.

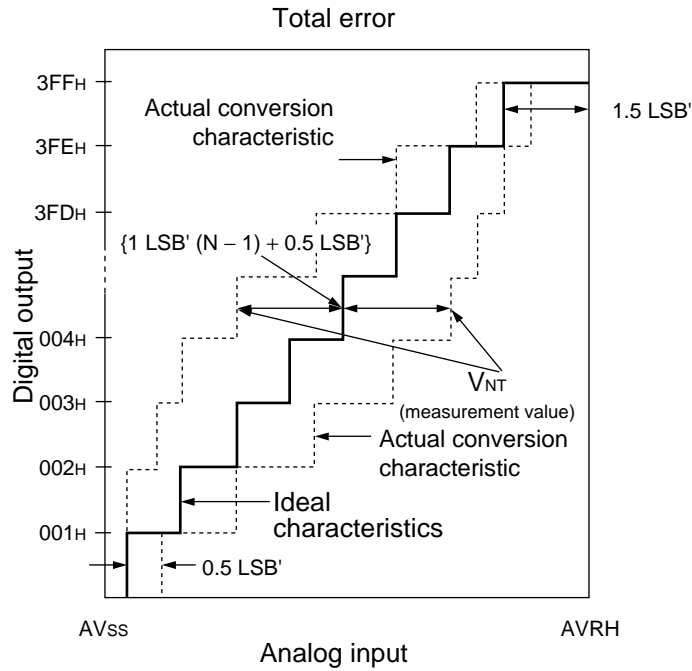

$$1\text{LSB}' (\text{Ideal value}) = \frac{\text{AVRH} - \text{AVSS}}{1024} [\text{V}]$$

$$\text{Total error of digital output } N = \frac{V_{\text{NT}} - \{1 \text{LSB}' \times (N - 1) + 0.5 \text{LSB}'\}}{1 \text{LSB}'}$$

N : A/D converter digital output value

V<sub>NT</sub> : The voltage at which the digital output transitions from (N + 1)<sub>H</sub> to N<sub>H</sub>

$$V_{\text{OT}}' (\text{Ideal value}) = \text{AVSS} + 0.5 \text{LSB}' [\text{V}]$$

$$V_{\text{FST}}' (\text{Ideal value}) = \text{AVRH} - 1.5 \text{LSB}' [\text{V}]$$

# MB91350A Series

## 6. Electrical Characteristics for the D/A Converter

( $V_{CC} = DAVC = 3.0\text{ V to }3.6\text{ V}$ ,  $V_{SS} = DAVS = AV_{SS} = 0\text{ V}$ ,  $T_a = -40\text{ }^{\circ}\text{C to }+85\text{ }^{\circ}\text{C}$ )

Parameter	Symbol	Pin name	Value			Unit	Remarks	
			Min	Typ	Max			
Resolution	—	—	—	—	8	bit		
Nonlinear error			-2.0	—	+2.0	LSB	When the output is unloaded	
Differential linear error			-1.0	—	+1.0		When the output is unloaded	
Conversion speed			—	—	—	0.6	—	$\mu\text{s}$
		3.0	When load capacitance ( $C_L$ ) = 100 pF					
Output high impedance	—	DA0, DA1	2.0	2.9	3.8	$\text{k}\Omega$	MB91F353A/353A/352A/351A	
		DA0 to DA2					MB91F355A/F356B/F357B/355A/354A	
Analog current	—	DAVC	—	40	—	$\mu\text{A}$	10 $\mu\text{s}$ conversion when the output is unloaded	
	$I_{ADA}$			—			460*	Input digital code, when fixed at 7A <sub>H</sub> or 85 <sub>H</sub>
	$I_{ADAH}$			0.1			—	At power-down

\* : This D/A converter varies in current consumption depending on each input digital code.

This rating indicates the current consumption when the digital code that maximizes current consumption is input.

## ■ FLASH MEMORY ERASE and PROGRAM PERFORMANCE

Parameter	Condition	Value			Unit	Remarks
		Min	Typ	Max		
Sector erase time	Ta = +25 °C Vcc = 3.3 V	—	1	15	s	Excludes 00H programming prior erasure
Chip erase time		—	8	—	s	Excludes 00H programming prior erasure
Half word (16-bit width) programming time		—	16	3600	μs	Excludes system-level overhead
Erase/program cycle	—	10000	—	—	cycle	
Flash data retention time	Average Ta = +85 °C	20	—	—	year	*

\* : This value comes from the technology qualification (using Arrhenius equation to translate high temperature measurements into normalized value at +85 °C).

# MB91350A Series

## EXAMPLE CHARACTERISTICS

• MB91F353A

“H” level output voltage

$V_{OH}$  vs.  $V_{CC}$   
 $T_a = +25\text{ }^\circ\text{C}$

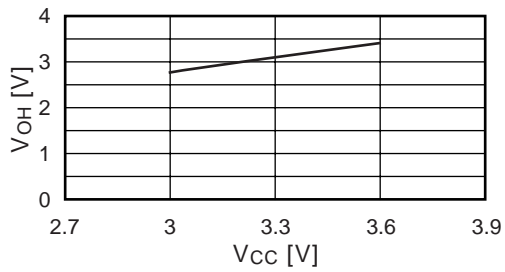

“L” level output voltage

$V_{OL1}$  vs.  $V_{CC}$   
 $T_a = +25\text{ }^\circ\text{C}$

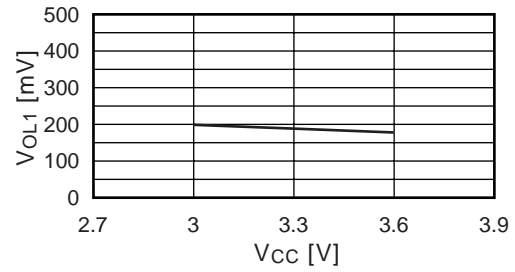

“L” level output voltage (N-ch open-drain)

$V_{OL2}$  vs.  $V_{CC}$   
 $T_a = +25\text{ }^\circ\text{C}$

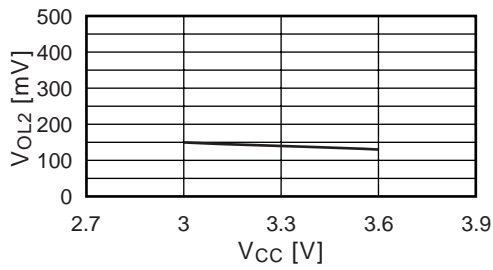

Input leak current

$I_{LI}$  vs.  $V_{CC}$   
 $T_a = +25\text{ }^\circ\text{C}$

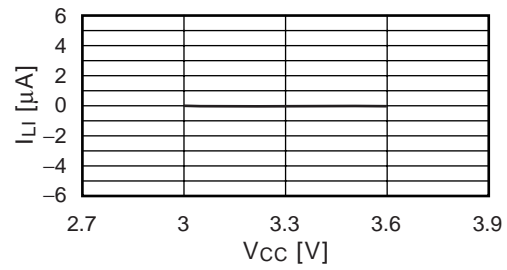

Pull-up resistance

$R_{UP}$  vs.  $V_{CC}$   
 $T_a = +25\text{ }^\circ\text{C}$

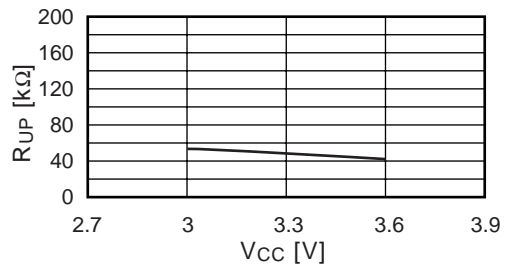

(Continued)

## Power supply current

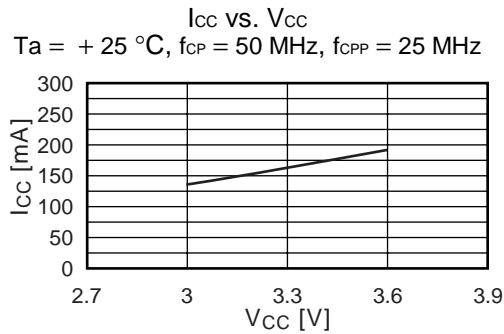

## Power supply current

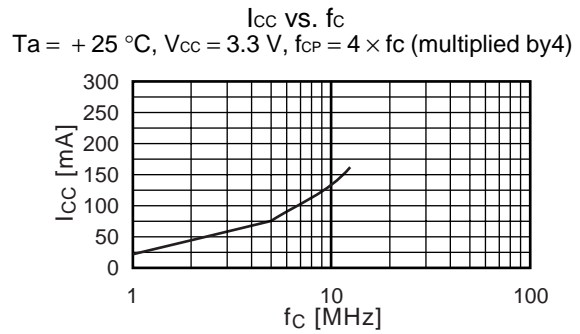

## Power supply current at sleep

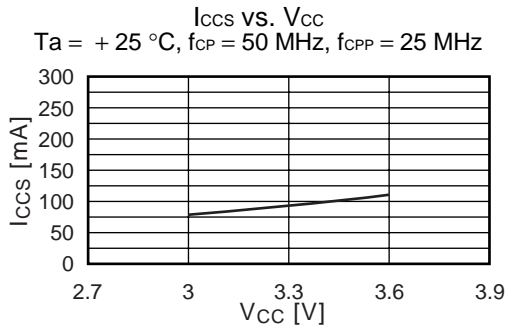

## Power supply current at sleep

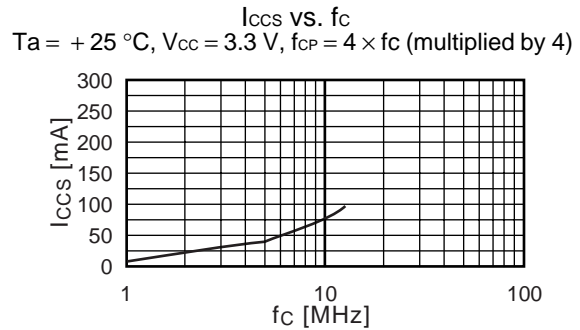

## Power supply current at stop

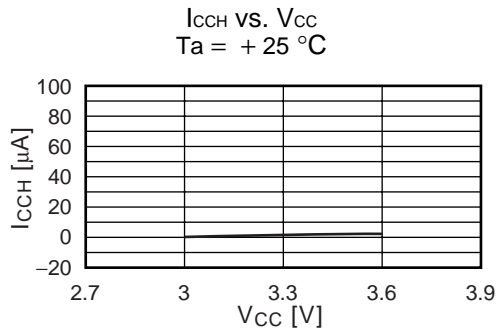

## Sub-RUN power supply current

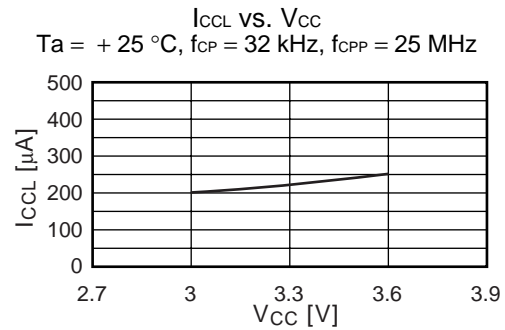

## Sub sleep power supply current

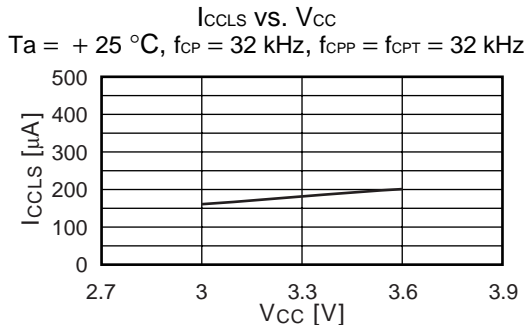

## Watch mode power supply current

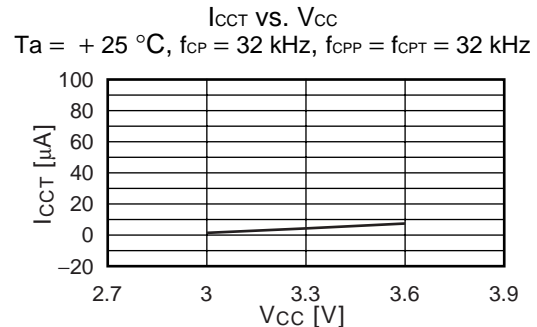

(Continued)

# MB91350A Series

(Continued)

A/D converter power supply current

$I_A$  vs.  $V_{CC}$   
 $T_a = +25\text{ }^\circ\text{C}$

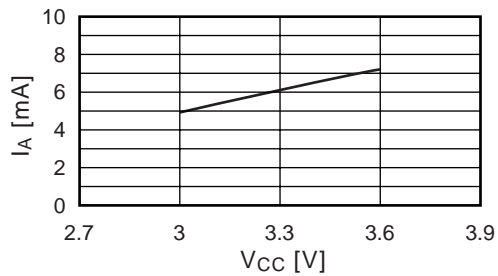

A/D converter reference power supply current

$I_R$  vs.  $V_{CC}$   
 $T_a = +25\text{ }^\circ\text{C}$

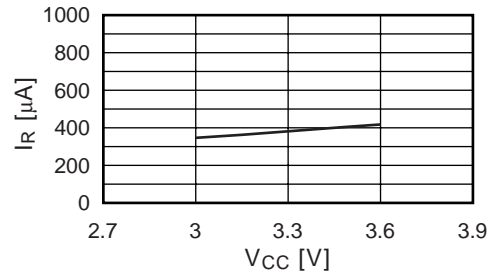

A/D converter power supply current at stop

$I_{AH}$  vs.  $V_{CC}$   
 $T_a = +25\text{ }^\circ\text{C}$

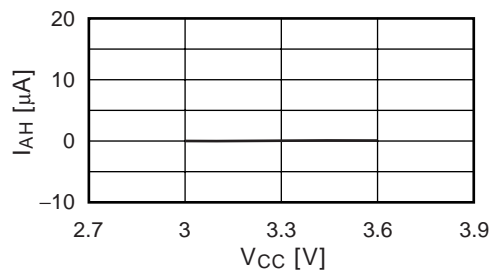

A/D converter reference power supply current at stop

$I_{RH}$  vs.  $V_{CC}$   
 $T_a = +25\text{ }^\circ\text{C}$

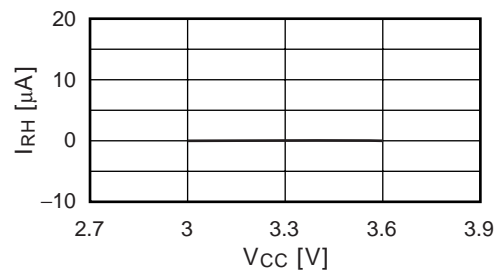

D/A converter power supply current  
 <per 1 channel>

$I_{ADA}$  vs.  $V_{CC}$   
 $T_a = +25\text{ }^\circ\text{C}$

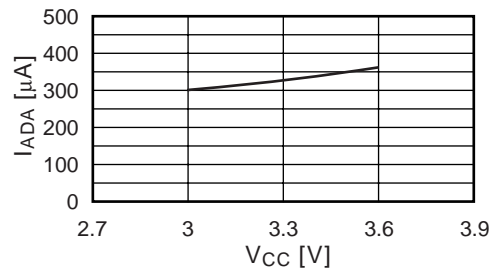

D/A converter power supply current  
 at power down

$I_{ADAH}$  vs.  $V_{CC}$   
 $T_a = +25\text{ }^\circ\text{C}$

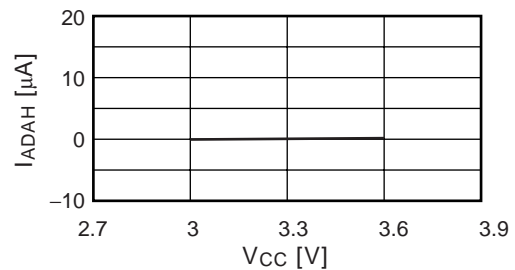

• MB91355A

“H” level output voltage

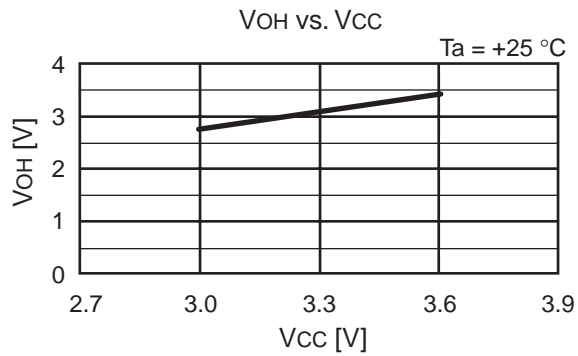

“L” level output voltage

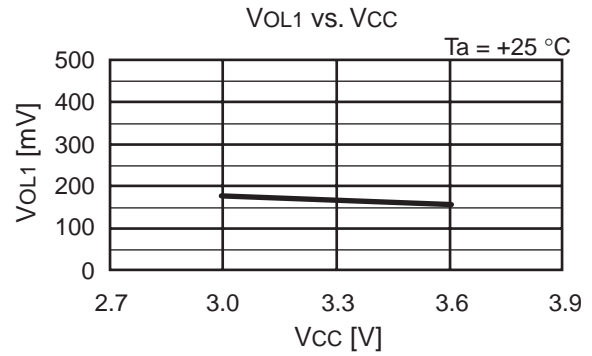

“L” level output voltage (N-ch open-drain)

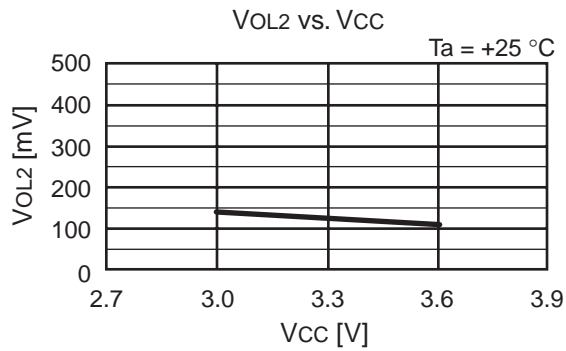

Input leak current

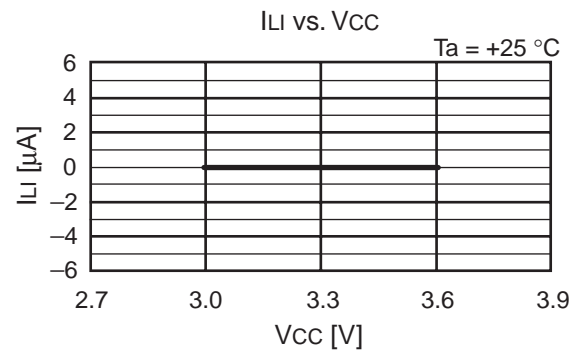

Pull-up resistance

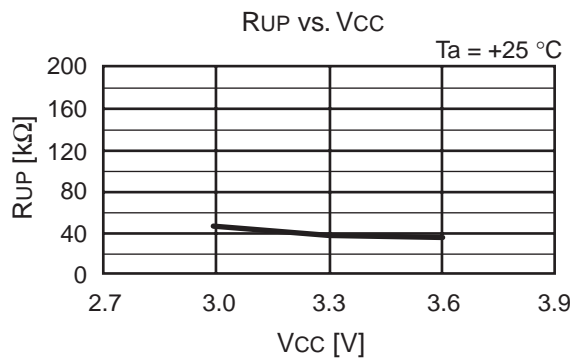

(Continued)

Power supply current

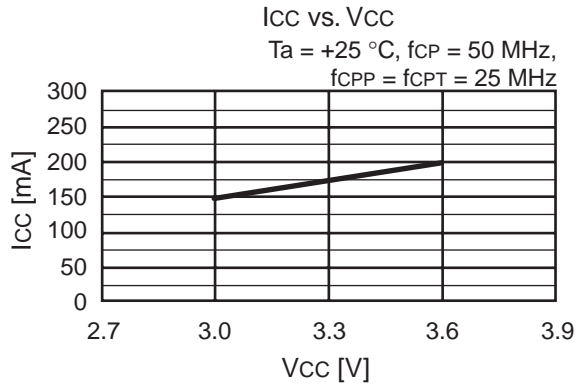

Power supply current

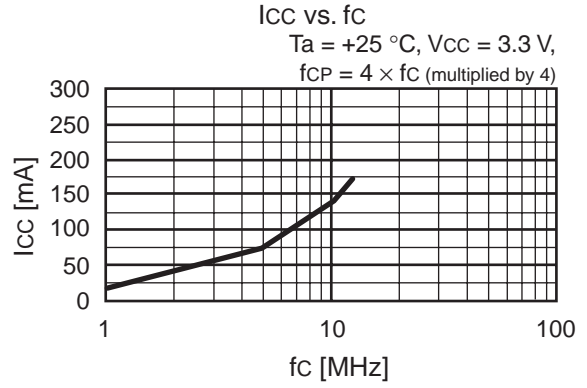

Power supply current at sleep

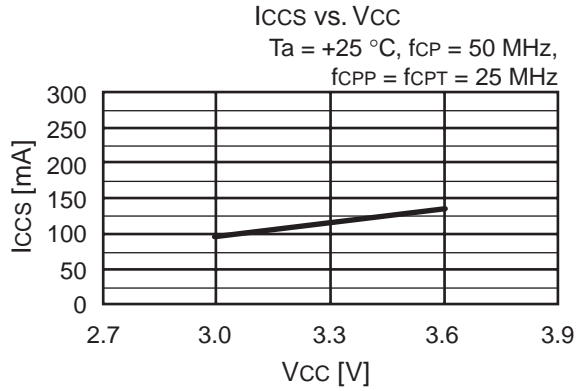

Power supply current at sleep

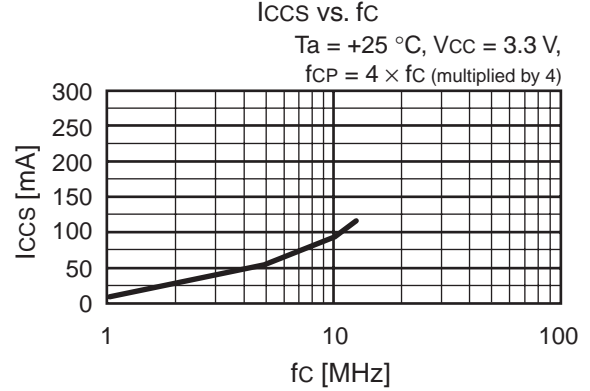

Power supply current at stop

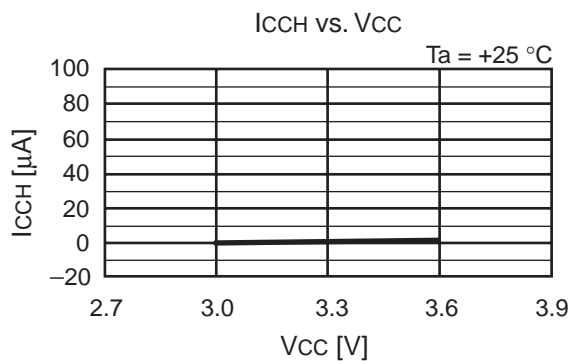

Sub RUN power supply current

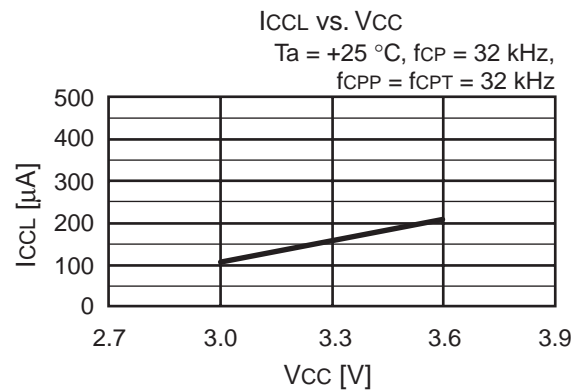

(Continued)

Sub sleep power supply current

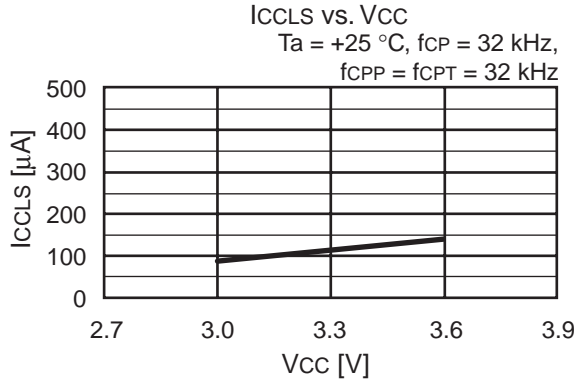

Watch mode power supply current

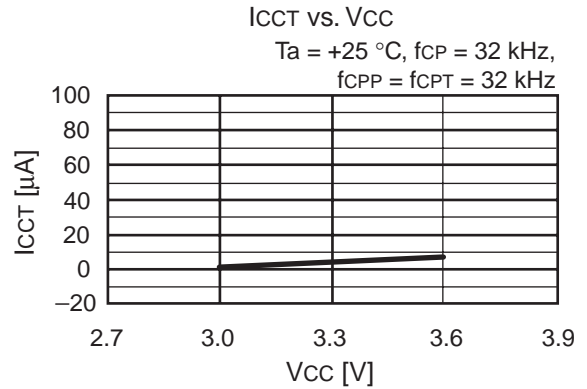

A/D converter power supply current

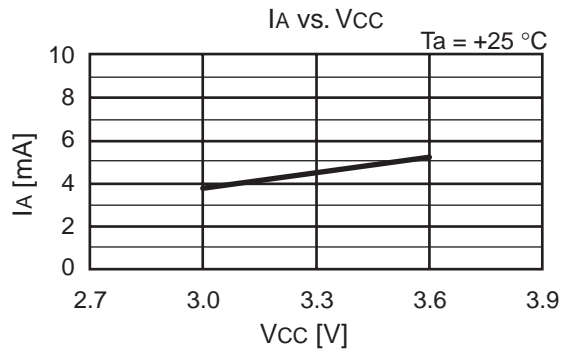

A/D converter reference power supply voltage

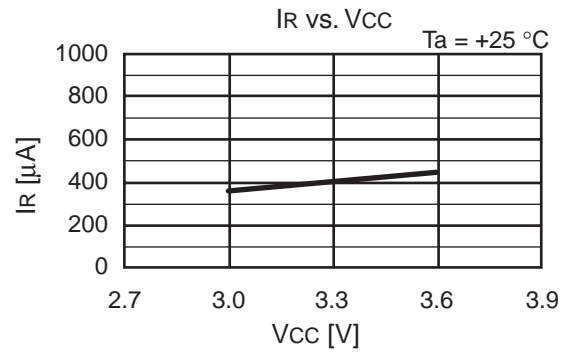

A/D converter power supply current at stop

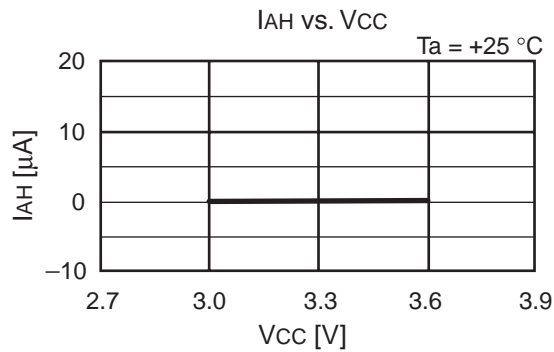

A/D converter reference power supply current at stop

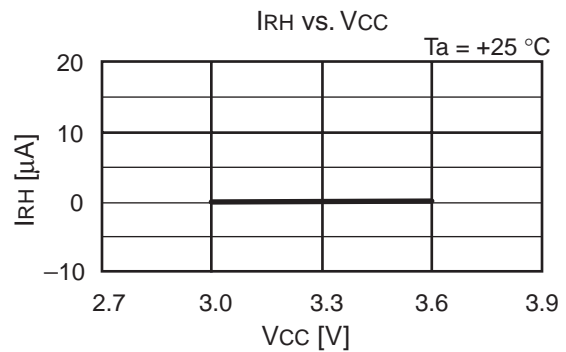

(Continued)

# MB91350A Series

(Continued)

D/A converter power supply current  
< per 1 channel >

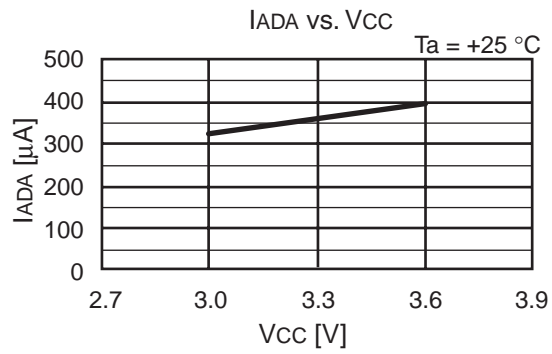

D/A converter power supply current at power down

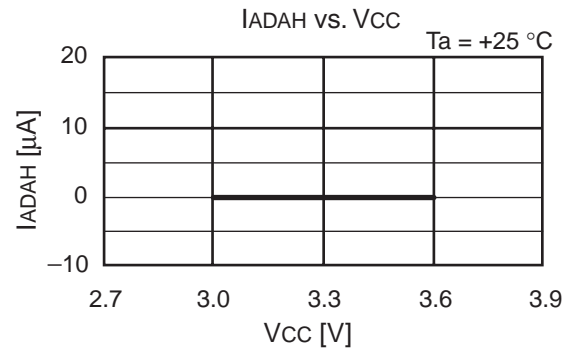

• MB91353A/352A/351A

“H” level output voltage

$V_{OH}$  vs.  $V_{CC}$   
 $T_a = +25\text{ }^\circ\text{C}$

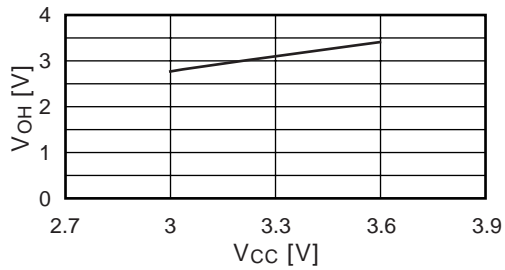

“L” level output voltage

$V_{OL1}$  vs.  $V_{CC}$   
 $T_a = +25\text{ }^\circ\text{C}$

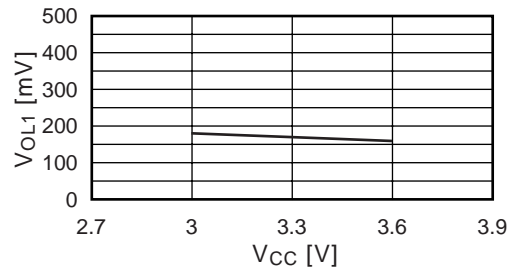

“L” level output voltage (N-ch open-drain)

$V_{OL2}$  vs.  $V_{CC}$   
 $T_a = +25\text{ }^\circ\text{C}$

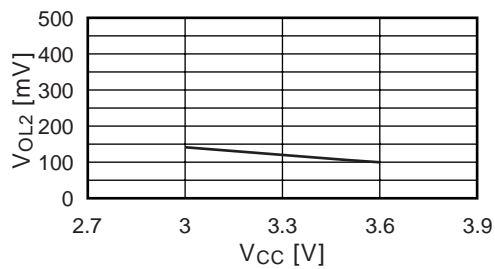

Input leak current

$I_{LI}$  vs.  $V_{CC}$   
 $T_a = +25\text{ }^\circ\text{C}$

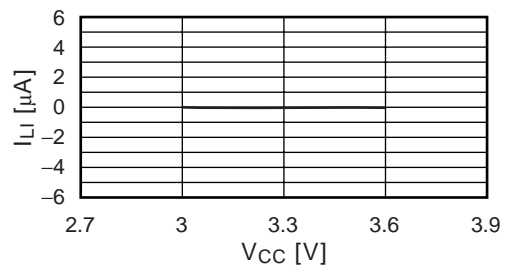

Pull-up resistance

$R_{UP}$  vs.  $V_{CC}$   
 $T_a = +25\text{ }^\circ\text{C}$

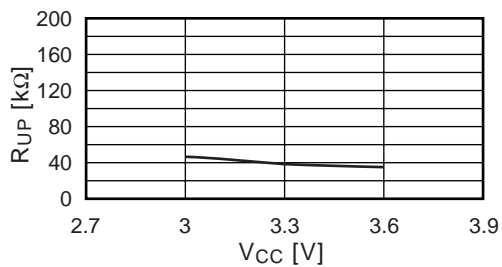

(Continued)

Power supply current

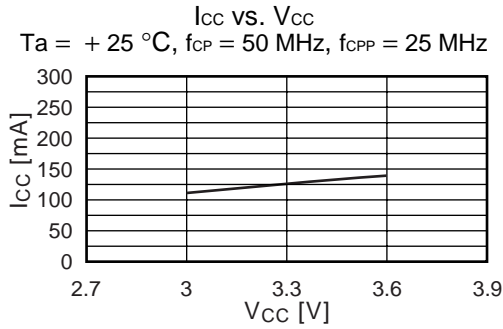

Power supply current

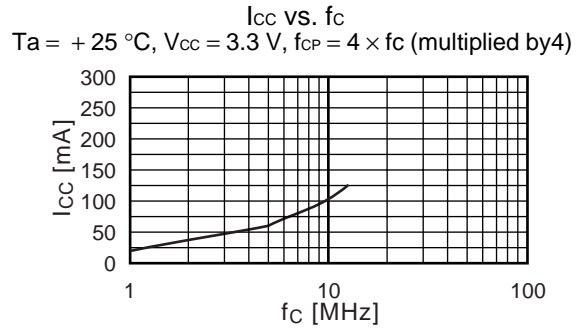

Power supply current at sleep

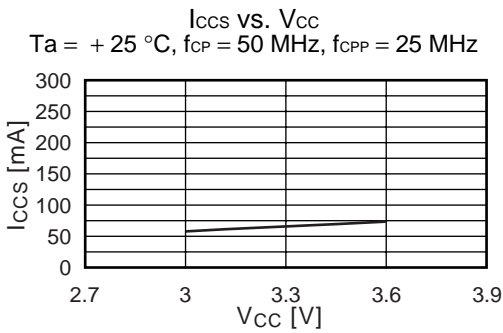

Power supply current at sleep

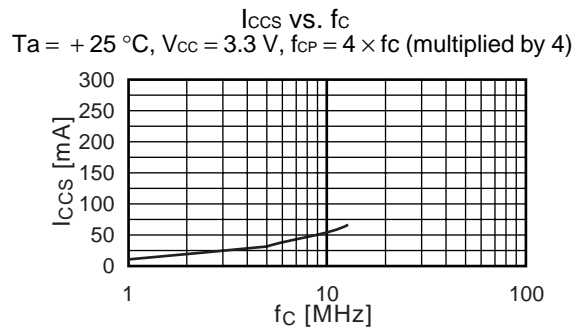

Power supply current at stop

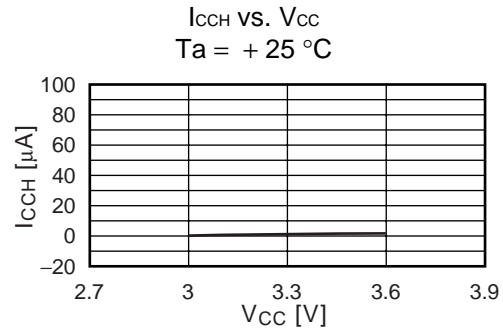

Sub-RUN power supply current

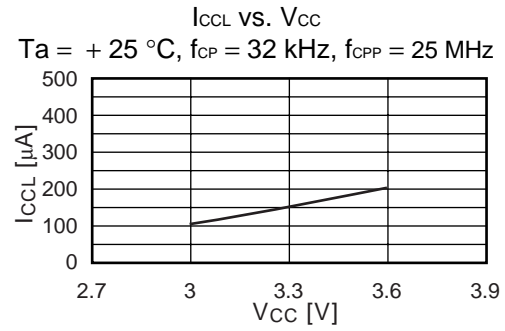

Sub sleep power supply current

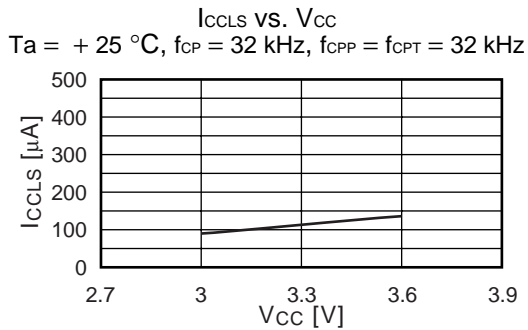

Watch mode power supply current

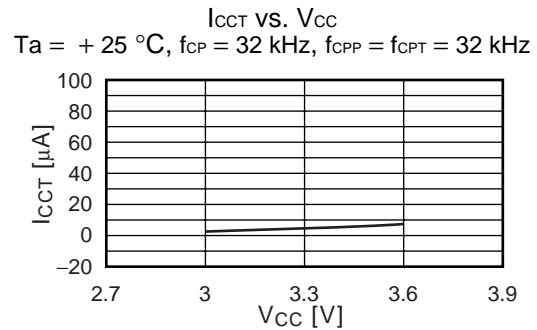

(Continued)

(Continued)

A/D converter power supply current

$I_A$  vs.  $V_{CC}$   
 $T_a = +25\text{ }^\circ\text{C}$

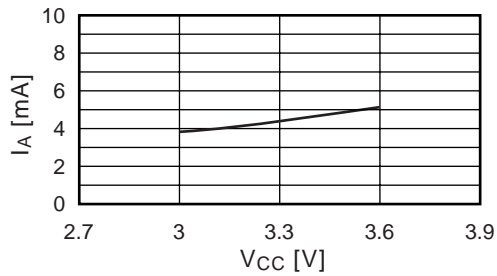

A/D converter reference power supply current

$I_R$  vs.  $V_{CC}$   
 $T_a = +25\text{ }^\circ\text{C}$

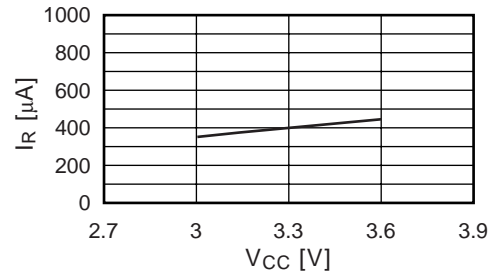

A/D converter power supply current at stop

$I_{AH}$  vs.  $V_{CC}$   
 $T_a = +25\text{ }^\circ\text{C}$

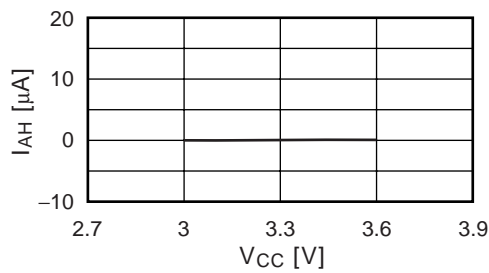

A/D converter reference power supply current at stop

$I_{RH}$  vs.  $V_{CC}$   
 $T_a = +25\text{ }^\circ\text{C}$

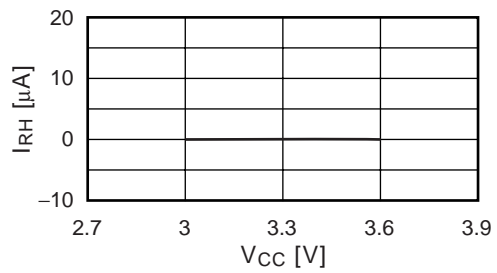

D/A converter power supply current  
 <per 1 channel>

$I_{ADA}$  vs.  $V_{CC}$   
 $T_a = +25\text{ }^\circ\text{C}$

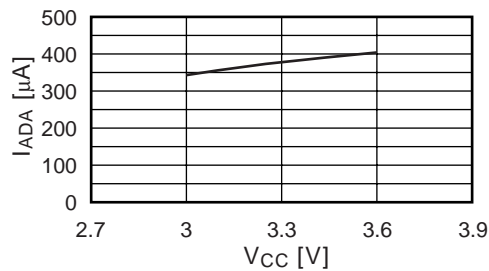

D/A converter power supply current  
 at power down

$I_{ADAH}$  vs.  $V_{CC}$   
 $T_a = +25\text{ }^\circ\text{C}$

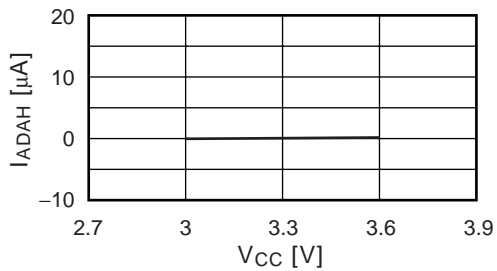

# MB91350A Series

## ■ ORDERING INFORMATION

Part number	Package	Remarks
MB91F355APMT-002	176-pin plastic LQFP (FPT-176P-M02)	Lead-free Package
MB91F356BPMT	176-pin plastic LQFP (FPT-176P-M02)	Lead-free Package
MB91F357BPMT	176-pin plastic LQFP (FPT-176P-M02)	Lead-free Package
MB91355APMT	176-pin plastic LQFP (FPT-176P-M02)	Lead-free Package
MB91354APMT	176-pin plastic LQFP (FPT-176P-M02)	Lead-free Package
MB91F353APMT	120-pin plastic LQFP (FPT-120P-M21)	Lead-free Package
MB91351APMT	120-pin plastic LQFP (FPT-120P-M21)	Lead-free Package
MB91352APMT	120-pin plastic LQFP (FPT-120P-M21)	Lead-free Package
MB91353APMT	120-pin plastic LQFP (FPT-120P-M21)	Lead-free Package

## PACKAGE DIMENSION

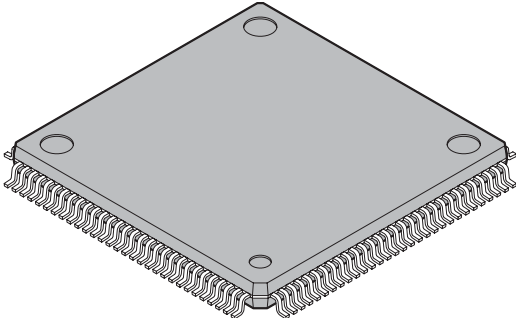
<p>120-pin plastic LQFP</p>  <p>(FPT-120P-M21)</p>	Lead pitch	0.50 mm
	Package width × package length	16.0 × 16.0 mm
	Lead shape	Gullwing
	Sealing method	Plastic mold
	Mounting height	1.70 mm MAX
	Weight	0.88 g
	Code (Reference)	P-LFQFP120-16×16-0.50

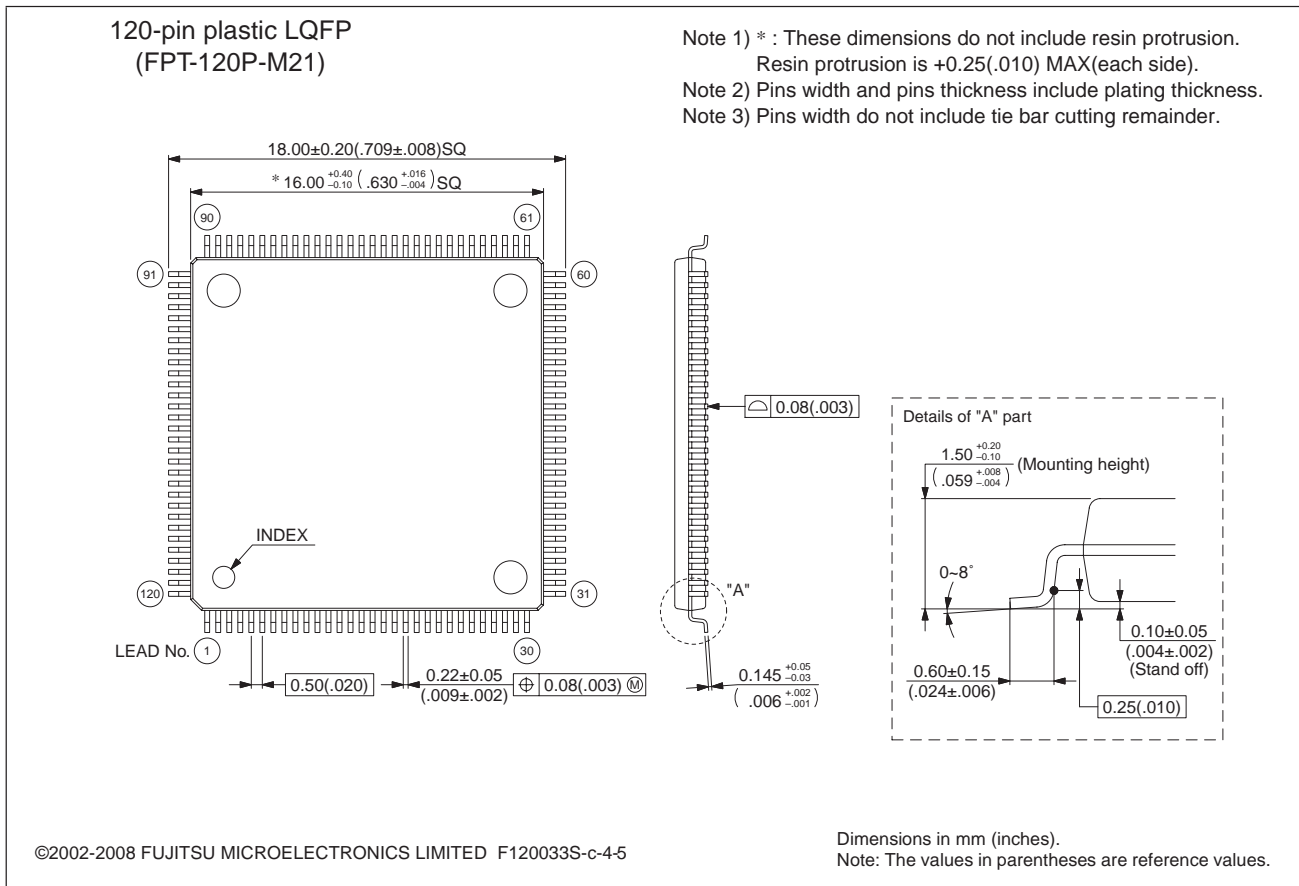

Please confirm the latest Package dimension by following URL.  
<http://edevice.fujitsu.com/package/en-search/>

(Continued)

# MB91350A Series

(Continued)

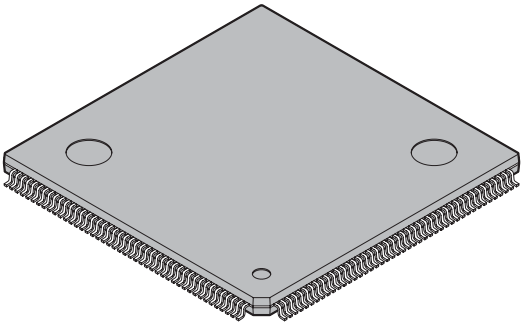
<p>176-pin plastic LQFP</p>  <p>(FPT-176P-M02)</p>	Lead pitch	0.50 mm
	Package width × package length	24.0 × 24.0 mm
	Lead shape	Gullwing
	Sealing method	Plastic mold
	Mounting height	1.70 mm MAX
	Weight	1.86g
	Code (Reference)	P-LFQFP176-24×24-0.50

176-pin plastic LQFP  
(FPT-176P-M02)

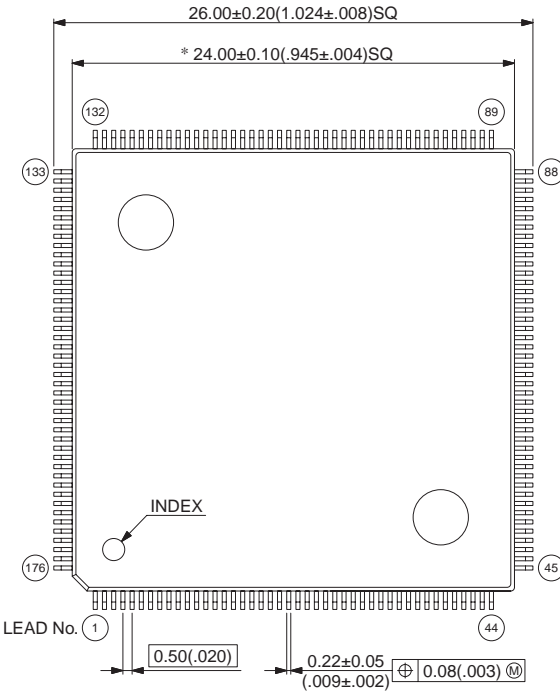

Note 1) \* : Values do not include resin protrusion.  
Resin protrusion is +0.25(.010)Max(each side).

Note 2) Pins width and pins thickness include plating thickness

Note 3) Pins width do not include tie bar cutting remainder.

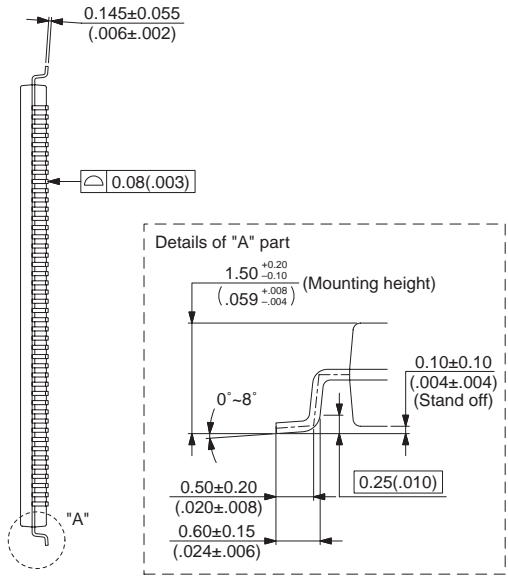

© 2003 FUJITSU LIMITED F176006S-c-4-6

Dimensions in mm (inches).  
Note: The values in parentheses are reference values.

Please confirm the latest Package dimension by following URL.  
<http://edevice.fujitsu.com/package/en-search/>

## ■ MAIN CHANGES IN THIS EDITION

Page	Section	Change Results
98	■ ELECTRICAL CHARACTERISTICS 4. AC Characteristics (1) Clock Timing	Changed the Internal operating clock frequency; Value (Min) : 2.94 → 3.13 Changed the Internal operating clock cycle time; Value (Max) : 340 → 320
118	■ ELECTRICAL CHARACTERISTICS (13) External Interrupt Input Timing	Added (13) External Interrupt Input Timing

The vertical lines marked in the left side of the page show the changes.

# MB91350A Series

## FUJITSU MICROELECTRONICS LIMITED

Shinjuku Dai-Ichi Seimei Bldg., 7-1, Nishishinjuku 2-chome,  
Shinjuku-ku, Tokyo 163-0722, Japan  
Tel: +81-3-5322-3347 Fax: +81-3-5322-3387  
<http://jp.fujitsu.com/fml/en/>

*For further information please contact:*

### North and South America

FUJITSU MICROELECTRONICS AMERICA, INC.  
1250 E. Arques Avenue, M/S 333  
Sunnyvale, CA 94085-5401, U.S.A.  
Tel: +1-408-737-5600 Fax: +1-408-737-5999  
<http://www.fma.fujitsu.com/>

### Asia Pacific

FUJITSU MICROELECTRONICS ASIA PTE. LTD.  
151 Lorong Chuan,  
#05-08 New Tech Park 556741 Singapore  
Tel : +65-6281-0770 Fax : +65-6281-0220  
<http://www.fmal.fujitsu.com/>

### Europe

FUJITSU MICROELECTRONICS EUROPE GmbH  
Pittlerstrasse 47, 63225 Langen, Germany  
Tel: +49-6103-690-0 Fax: +49-6103-690-122  
<http://emea.fujitsu.com/microelectronics/>

### FUJITSU MICROELECTRONICS SHANGHAI CO., LTD.

Rm. 3102, Bund Center, No.222 Yan An Road (E),  
Shanghai 200002, China  
Tel : +86-21-6146-3688 Fax : +86-21-6335-1605  
<http://cn.fujitsu.com/fmc/>

### Korea

FUJITSU MICROELECTRONICS KOREA LTD.  
206 Kosmo Tower Building, 1002 Daechi-Dong,  
Gangnam-Gu, Seoul 135-280, Republic of Korea  
Tel: +82-2-3484-7100 Fax: +82-2-3484-7111  
<http://kr.fujitsu.com/fmk/>

### FUJITSU MICROELECTRONICS PACIFIC ASIA LTD.

10/F., World Commerce Centre, 11 Canton Road,  
Tsimshatsui, Kowloon, Hong Kong  
Tel : +852-2377-0226 Fax : +852-2376-3269  
<http://cn.fujitsu.com/fmc/en/>

Specifications are subject to change without notice. For further information please contact each office.

### All Rights Reserved.

The contents of this document are subject to change without notice.

Customers are advised to consult with sales representatives before ordering.

The information, such as descriptions of function and application circuit examples, in this document are presented solely for the purpose of reference to show examples of operations and uses of FUJITSU MICROELECTRONICS device; FUJITSU MICROELECTRONICS does not warrant proper operation of the device with respect to use based on such information. When you develop equipment incorporating the device based on such information, you must assume any responsibility arising out of such use of the information.

FUJITSU MICROELECTRONICS assumes no liability for any damages whatsoever arising out of the use of the information.

Any information in this document, including descriptions of function and schematic diagrams, shall not be construed as license of the use or exercise of any intellectual property right, such as patent right or copyright, or any other right of FUJITSU MICROELECTRONICS or any third party or does FUJITSU MICROELECTRONICS warrant non-infringement of any third-party's intellectual property right or other right by using such information. FUJITSU MICROELECTRONICS assumes no liability for any infringement of the intellectual property rights or other rights of third parties which would result from the use of information contained herein.

The products described in this document are designed, developed and manufactured as contemplated for general use, including without limitation, ordinary industrial use, general office use, personal use, and household use, but are not designed, developed and manufactured as contemplated (1) for use accompanying fatal risks or dangers that, unless extremely high safety is secured, could have a serious effect to the public, and could lead directly to death, personal injury, severe physical damage or other loss (i.e., nuclear reaction control in nuclear facility, aircraft flight control, air traffic control, mass transport control, medical life support system, missile launch control in weapon system), or (2) for use requiring extremely high reliability (i.e., submersible repeater and artificial satellite).

Please note that FUJITSU MICROELECTRONICS will not be liable against you and/or any third party for any claims or damages arising in connection with above-mentioned uses of the products.

Any semiconductor devices have an inherent chance of failure. You must protect against injury, damage or loss from such failures by incorporating safety design measures into your facility and equipment such as redundancy, fire protection, and prevention of over-current levels and other abnormal operating conditions.

Exportation/release of any products described in this document may require necessary procedures in accordance with the regulations of the Foreign Exchange and Foreign Trade Control Law of Japan and/or US export control laws.

The company names and brand names herein are the trademarks or registered trademarks of their respective owners.

Edited: Business & Media Promotion Dept.