

32-Bit Microcontroller

CMOS

FR30 Family MB91129 Series

MB91F127/F128

■ DESCRIPTION

This MB91129 Series, designed on the basis of 32-bit RISC CPU (FR30* series), is a standard single-chip micro controller with built-in I/O resources and bus control functions. The functions are suitable for built-in control that requires high-speed CPU processing.

MB91F127 includes 256 Kbytes built-in flash memory and 14 Kbytes built-in RAM. MB91F128 includes 510 Kbytes built-in flash memory and 14 Kbytes built-in RAM.

The specifications of the devices are best suited for applications requiring high-level CPU processing capabilities, such as navigation system, high-performance FAX, and printer controller.

* : FR, the abbreviation of FUJITSU RISC controller, is a line of products of Fujitsu Microelectronics Limited.

■ FEATURES

FR-CPU

- 32-bit RISC (FR30), load/store architecture, 5-step pipeline
- Operating frequency : Internal 25 MHz
- General register : 32bit x 16 registers
- 16-bit fixed-length instructions (primitives), 1 instruction/1 cycle
- Instructions of memory-to-memory transfer, bit processing, and barrel shift : Instructions suitable for built-in control
- Function entry/exit instructions, multi load/store instruction for register data : High-level language compatible instructions
- Register interlock functions : Simple description of assembler language
- Branch instructions with delay slot : Reduced overhead on branching process
- Built-in multiplier/ Supporting at instruction level
 - Signed 32-bit multiplying : 5 cycles
 - Signed 16-bit multiplying : 3 cycles
- Interrupt (saving PC and PS) : 6 cycles, 16 priority levels

For the information for microcontroller supports, see the following web site.

<http://edevic.fujitsu.com/micom/en-support/>

(Continued)

Bus interface

- Maximum of 25 MHz internal operation rate
- 25-bit address bus (32 MB space)
- 16-bit address output, 8/16-bit data input/output
- Basic bus cycle : 2-clock cycle
- Chip selection outputs specifiable in a minimum of 64 Kbytes steps : 6 outputs
- Automatic wait cycle : Specifiable flexibly from 0 cycle to 7 cycles for each area
- Supporting time-division input/output interface for address/data (for area 1 only)
- Unassigned data/address pins are available as input/output ports
- Supporting little endian mode (selecting one area from area 1 to area 5)

DMAC (DMA controller)

- 8 channels
- Transfer factor : Interrupt request of built-in resources
- Transfer sequence : Step transfer/Block transfer/Burst transfer/Consecutive transfer
- Transfer data length : Selectable among 8 bits, 16 bits, and 32 bits
- Pausing is allowed by interrupt request

UART

- 3 channels
- Full-duplex double buffer
- Data length : 7 to 9 bits (no parity), 6 to 8 bits (with parity)
- Asynchronous (start-stop synchronization) or CLK synchronous communication is selectable
- Multi processor mode
- Built-in 16-bit timer (U-Timer) used as a baud-rate generator : Generates an arbitrary baud rate
- External clock is available as a transfer clock
- Error detection : parity, frame, and overrun

A/D converter (sequential transducer)

- 8/10-bit resolution, 8 channels
- Sequential comparison and transducer : At 25 MHz, 5.2 μ s
- Built-in sample and hold circuit
- Conversion mode : Selectable among single conversion, scan conversion, and repeat conversion
- Activation : Selectable among software, external trigger, and built-in timer

Reload timer

- 16-bit timer : 3 channels
- Internal clock : 2-clock cycle resolution, selectable among 2/8/32 dividing and external clock

Other interval timers

- 16-bit timer : 3 channels (U-Timer)
- PPG timer : 4 channels
- 16-bit OCU : 4 channels, ICU : 4 channels, Free-run timer : 1 channel
- Watchdog timer: 1 channel

Flash memory 510 KB

- 510 KB FLASH ROM: Read/Write/Erase is allowed with a same power

(Continued)

(Continued)

Built-in RAM 14 KB

- D-bus RAM 12 KB, C-bus RAM 2 KB

Bit search module

- Position of a first bit that changes between “1” and “0” is searched in one cycle, within an MSB of one word.

Interrupt controller

- External interrupt input : Normal interrupt×6 (INT0 to INT5)
- Internal interrupt factors : UART, DMAC, A/D, Reload timer, UTIMER, delay interrupt, PPG, ICU, and OCU
- Priority levels are programmable (16 levels)

Reset factors

- Power-on reset/watchdog timer/software reset/external reset

Low power consumption mode

- Sleep/stop mode

Clock control

- Built-in PLL circuit, selectable among 1-multiplication, and 2-multiplication
- Gearing function : Operation clock frequencies are freely and independently specifiable for CPU and peripherals.
Gear clocks are selectable among 1/1, 1/2, 1/4, and 1/8 (or among 1/2, 1/4, 1/8, and 1/16).
Upper limit of peripheral operations is 25 MHz.

Others

- Package : LQFP-100
- CMOS technology : 0.35 μm
- Power supply voltage : 3.3 V±0.3 V

■ SERIES CONFIGURATION

Model name	MB91F127	MB91F128	MB91FV129
Outline	Quantity production	Quantity production	Evaluation product
FLASH memory	256 KB	510 KB	510 KB
D-bus RAM	12 KB	12 KB	16 KB
C-bus RAM	2 KB	2 KB	2 KB

MB91129 Series

PIN ASSIGNMENT

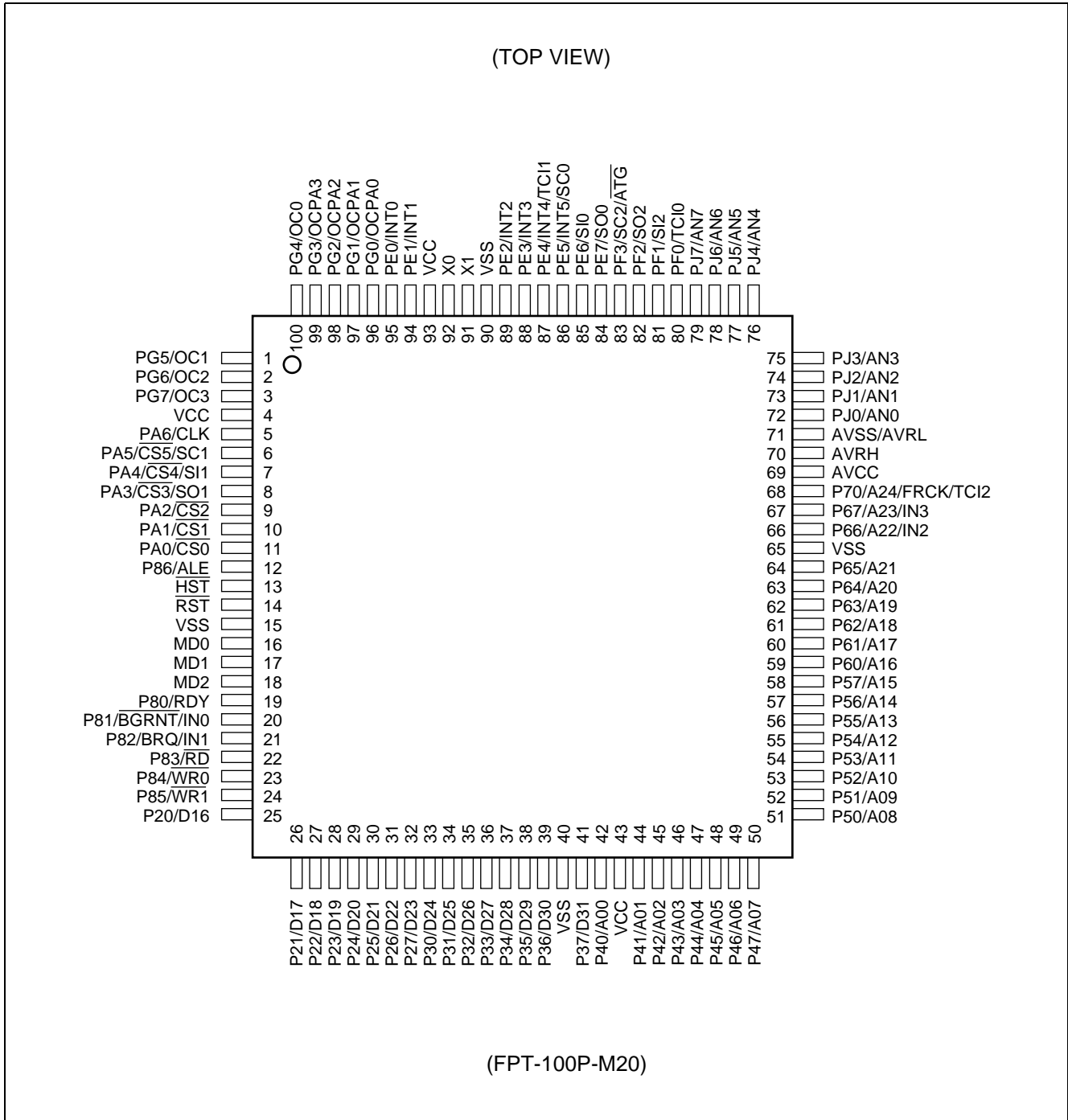

■ PIN DESCRIPTION

Note that the numbers in the table are not pin numbers on a package.

No.	Pin name	Input/output circuit type	Description
1 2 3 4 5 6 7 8	D16/P20 D17/P21 D18/P22 D19/P23 D20/P24 D21/P25 D22/P26 D23/P27	D	Bit 16 through bit 23 of external data bus. The pins are available as general I/O ports (P20 through P27) when external bus width is specified at 8 bits or in single-chip mode.
9 10 11 12 13 14 15 16	D24/P30 D25/P31 D26/P32 D27/P33 D28/P34 D29/P35 D30/P36 D31/P37	D	Bit 24 through bit 31 of external data bus. The pins are available as general I/O ports (P30 through P37) when the pins are not used.
17 18 19 20 21 22 23 24 25 26 27 28 29 30 31 32	A00/P40 A01/P41 A02/P42 A03/P43 A04/P44 A05/P45 A06/P46 A07/P47 A08/P50 A09/P51 A10/P52 A11/P53 A12/P54 A13/P55 A14/P56 A15/P57	D	Bit 00 through bit 15 of external address bus. The pins are available as general I/O ports (P40 through P47 and P50 through P57) when the pins are not used as address buses.
33 34 35 36 37 38 39 40	A16/P60 A17/P61 A18/P62 A19/P63 A20/P64 A21/P65 A22/P66/IN2 A23/P67/IN3	D	Bit 16 through bit 23 of external address bus. The pins are available as general I/O ports (P60 through P67) when the pins are not used as address buses. [IN2,IN3]: Input pins of input capture. This function is active when input capture is operating.

(Continued)

MB91129 Series

No.	Pin name	Input/output circuit type	Description												
41	A24/P70/FRCK/TCI2	D	Bit 24 of external address bus. [P70] A24, FRCK and TCI2 are available as general input ports when they are not used. [FRCK] External clock input of free-run timer. This function is active when external clock input of free-run timer is used. [TCI2] External clock input of timer 2. This function is active when external clock input of timer 2 is used.												
42	RDY/P80	D	External ready input. Enter "0" when bus cycle under execution does not complete. This pin is available as general input/output port when it is not used.												
43	$\overline{\text{BGRNT}}$ /P81/IN0	D	External bus open receive output. This pin outputs "L" when an external bus is released. This pin is available as general input/output port when it is not used. [IN0] Input capture input. This function is active when input capture is under input operation.												
44	BRQ/P82/IN1	D	External bus open request input. Enter "1" when releasing external bus. This pin is available as general input/output port when it is not used. [IN1] Input capture input. This function is active when input capture is under input operation.												
45	$\overline{\text{RD}}$ /P83	D	External bus read strobe. This pin is available as general input/output port when it is not used.												
46	$\overline{\text{WR0}}$ /P84	D	External bus write strobe. Control signals and data bus byte positions are related as the following :												
47	$\overline{\text{WR1}}$ /P85	D	<table border="1"> <thead> <tr> <th></th> <th>16-bit bus width</th> <th>8-bit bus width</th> <th>Single chip mode</th> </tr> </thead> <tbody> <tr> <td>D31 to D24</td> <td>$\overline{\text{WR0}}$</td> <td>$\overline{\text{WR0}}$</td> <td>(port allowed)</td> </tr> <tr> <td>D23 to D16</td> <td>$\overline{\text{WR1}}$</td> <td>(port allowed)</td> <td>(port allowed)</td> </tr> </tbody> </table>		16-bit bus width	8-bit bus width	Single chip mode	D31 to D24	$\overline{\text{WR0}}$	$\overline{\text{WR0}}$	(port allowed)	D23 to D16	$\overline{\text{WR1}}$	(port allowed)	(port allowed)
				16-bit bus width	8-bit bus width	Single chip mode									
			D31 to D24	$\overline{\text{WR0}}$	$\overline{\text{WR0}}$	(port allowed)									
D23 to D16	$\overline{\text{WR1}}$	(port allowed)	(port allowed)												
Note : $\overline{\text{WR1}}$ is set to Hi-Z during resetting. For using with 16-bit bus width, use an external pull-up resistor. [P84 or P85] Available as general input/output ports when $\overline{\text{WR0}}$ and $\overline{\text{WR1}}$ are not used.															
48 49 50	$\overline{\text{CS0}}$ /PA0 $\overline{\text{CS1}}$ /PA1 $\overline{\text{CS2}}$ /PA2	D	Chip select 0 output (Low active) Chip select 1 output (Low active) Chip select 2 output (Low active) [PA0, 1, or 2] Available as general input/output ports when $\overline{\text{CS0}}$, $\overline{\text{CS1}}$ and $\overline{\text{CS2}}$ are not used.												

(Continued)

MB91129 Series

No.	Pin name	Input/output circuit type	Description
51 52 53	$\overline{CS3}$ /PA3/SO1 $\overline{CS4}$ /PA4/SI1 $\overline{CS5}$ /PA5/SC1	D	Chip select 3, 4, 5 output (Low active). [PA3,4,5] Available as general input/output ports when channel 1 of chip select UART is not used. [SO1,SI1,SC1] Data output, data input, and clock pins of UART1. Active when UART1 operation is allowed.
54	CLK/PA6	D	System clock output. Outputs a same clock as the same frequency of external bus operation. [PA6] Available as general input/output ports it is not used.
55 56 57 58 59 60 61 62	OCPA0/PG0 OCPA1/PG1 OCPA2/PG2 OCPA3/PG3 OC0/PG4 OC1/PG5 OC2/PG6 OC3/PG7	D	[OCPA0 to 3] PPG timer outputs. The function is active when PPG timer output is allowed. [OC0 to 3] Output comparison output. The function is active when output comparison output is allowed. [PB0-7] Available as general input/output ports it is not used.
63 64 65	MD0 MD1 MD2	B	Mode pins 0 through 2. The pins specify basic operation mode of MCU. Use the pins by connecting them directly to VCC or VSS.
66 67	X0 X1	A	Clock (oscillation) input. Clock (oscillation) output.
68	\overline{RST}	C	External reset input.
69	\overline{HST}	C	Hardware standby input.
70	P86/ALE	D	[ALE] Address latch signal output. The function is active when ALE output of EPCR is allowed.
71 72	INT0/PE0 INT1/PE1 INT2/PE2 INT3/PE3	D	[INT0,1,2,3] External interrupt request inputs. The input is used whenever necessary if external interrupt is allowed. Output of other functions must be suspended if not on purpose. [PE0,1,2,3] General input/output port
75 76	INT4/PE4/TC11 INT5/PE5/SC0	D	[INT4,5] External interrupt request inputs. The input is used whenever necessary if concerned external interrupt is allowed. Output of other functions must be suspended if not on purpose. [TC11] External clock input of timer 1. [SC0] Clock input of UART0. [PE4,5] General input/output port
77	SI0/PE6	D	[SI0] Data input of UART0. This function is active when data input of UART0 is allowed. [PE6] General input/output port
78	SO0/PE7	D	[SO0] Data output of UART0. This function is active when data output of UART0 is allowed. [PE7] General input/output port

(Continued)

MB91129 Series

(Continued)

No.	Pin name	Input/output circuit type	Description
79	PF0/TCI0	D	[TCI0] External clock input of timer 0.
			[PF0] General input/output port
80	SI2/PF1	D	[SI2] Data input of UART2. This function is active when data input of UART2 is allowed.
			[PF1] General input/output port
81	SO2/PF2	D	[SO2] Data output of UART2. This function is active when data output of UART2 is allowed.
			[PF2] General input/output port. This function is active when data output of UART2 is disallowed.
82	SC2/PF3/ $\overline{\text{ATG}}$	D	[SC2] Clock input of UART2 [ATG] External trigger input of A/D converter. The input is used whenever necessary if a function concerned is selected. Output of other functions must be suspended if not on purpose.
			[PF3] General input/output port
83 to 90	AN0/PJ0 AN1/PJ1 AN2/PJ2 AN3/PJ3 AN4/PJ4 AN5/PJ5 AN6/PJ6 AN7/PJ7	E	[AN0 to AN7] Analog input of A/D converter. This function is active when analog input is specified in AIC register.
			[PJ0 through PJ7] General input/output ports
91	AVCC	—	VCC power supply for A/D converter
92	AVRH	—	Reference voltage of A/D converter (high potential side). Be sure to turn on or off this pin with a potential higher than AVRH applied to VCC.
93	AVSS/AVRL	—	A/D converter VSS power source and reference voltage (low potential side).
94 to 96	VCC	—	Power sources of digital circuits. Be sure to connect power source to all pins when the device is used.
97 to 100	VSS	—	Ground level of digital circuits.

Note : Most of the above pins multiplex inputs and outputs of I/O ports and resources, as indicated as "XXXX/PXX".
If the outputs of ports and resources conflict with each other on the pins, resources take preferences.

INPUT/OUTPUT CIRCUIT TYPE

Type	Circuit	Remarks
A		<ul style="list-style-type: none"> • For 25 MHz system • Oscillation feedback register : Approx. 1MΩ • Standby control is available.
B		<ul style="list-style-type: none"> • CMOS level input • High-voltage control is available for FLASH test.
C		<ul style="list-style-type: none"> • CMOS level hysteresis input • Standby control is not available.
D		<ul style="list-style-type: none"> • CMOS level output • CMOS level hysteresis input • Standby control is available
E		<ul style="list-style-type: none"> • Standby control is available • CMOS level output • CMOS level hysteresis input • Analog input

■ HANDLING DEVICES

1. Preventing latch up

On a CMOS IC, latch up may occur when a voltage higher than VCC or a voltage lower than VSS is applied to input pin or output pin, or when a voltage exceeding rated level is applied across VCC and VSS. Latch up causes drastic increase of power source current, which may result in destruction of the element by heat. Take extra care not to exceed maximum rating in use. Also, take extra care so that analog pin does not exceed digital power source.

2. Treatment of unused input pins

Leaving unused pins open may cause malfunction. Apply pull-up or pull-down treatment on unused pins.

3. External reset input

Complete resetting of internal system requires inputting "L" level signal to $\overline{\text{RST}}$ pin for a minimum of 5 machine cycles.

4. Notes on using external clock

When using an external clock, supply a clock signal to X0 pin and supply its antiphase clock to X1 pin simultaneously. In this case, do not use STOP mode (oscillation stop mode). (Because X1 pin halts with "H" output under STOP status.)

Under a 12.5 MHz frequency, the device operates with a clock supplied to X0 pin only.

Figures show examples of using an external clock.

Example of using external clock (normal)

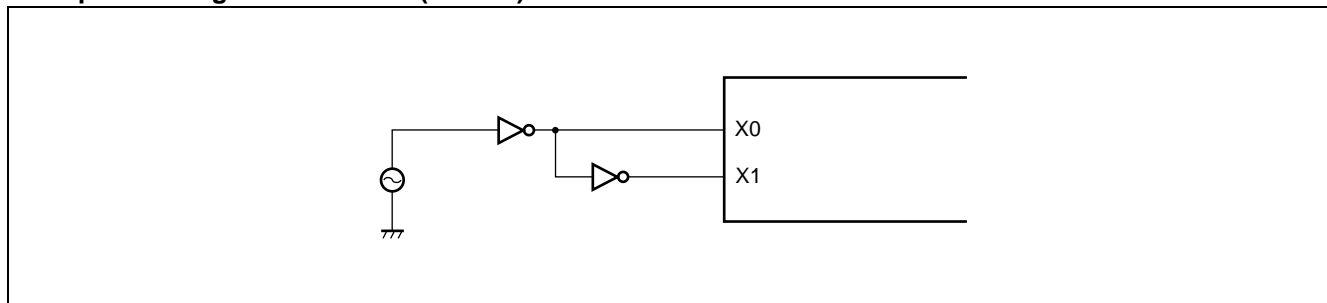

Note : STOP mode (oscillation stop mode) is not available.

Example of using external clock (allowed under operation at 12.5 MHz or lower frequency)

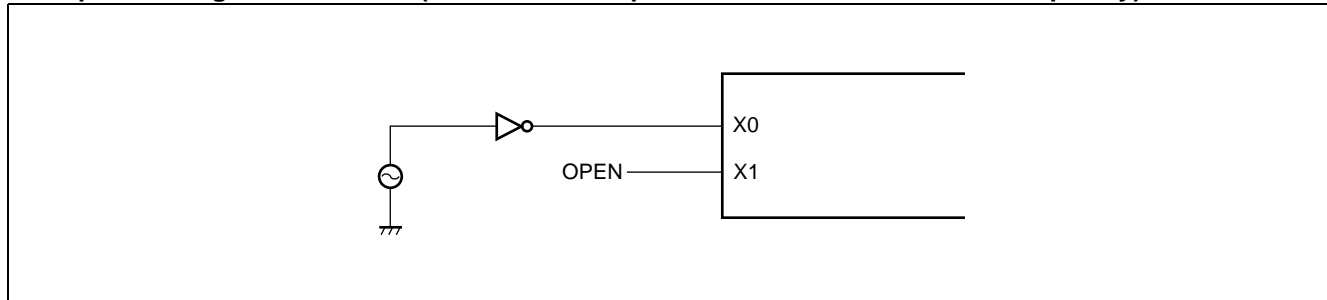

5. Connecting power supply pins (VCC, VSS)

If two or more VCC, VSS pins are used, the pins to be placed under the same potentials are connected with each other internally for preventing malfunctions such as latch up. However, for reducing unwanted radiation, preventing malfunctions of strobe signals and observing total power and current ratings, be sure to connect all of these pins to power supply and ground externally.

Connecting power supply to VCC - VSS in impedance as low as possible is desirable.

6. Crystal oscillator circuit

Noises around X0 and X1 pins causes malfunction of the device. Design printed wiring so that X0, X1, and crystal oscillator (or ceramic oscillator), and bypass capacitor to the ground are aligned as close as possible one another. Also the wiring of those elements should not cross with other wiring if possible. Printed wiring with ground wires around X0 and X1 pins ensures more stable operations. Such designing is strongly recommended.

7. Treating NC pins

Be sure to leave NC pins open.

8. Mode pins (MD0 through MD2)

Do not connect the mode pins directly to VCC or VSS.

For preventing malfunctions caused by noises, make printed traces between the mode pins and VCC or VSS as short as possible, and connect the elements in lower impedance.

9. Turning power on

Be sure to turn on the power of the device with $\overline{\text{RST}}$ pin placed under "L" level. Ensure a period at a minimum of 5 cycles of internal operation clock before placing the pin under "H" level.

10. Pin status upon turning on power

Status upon turning on the power is indefinite. Upon turning on the power, oscillation starts and the circuit is initialized.

11. Oscillation input upon turning on power

Upon turning on the power, be sure to input a clock signal until oscillation stabilizing wait status is released.

12. Initializing power-on reset

The device includes some built-in registers that are initialized only with power-on reset operation. For initializing the registers, perform power-on reset by turning on the power again.

13. Recovery from Sleep/Stop status

For recovering from Sleep/Stop status initiated by a program in C-Bus RAM, reset the device instead of recovering by an interrupt process.

MB91129 Series

■ BLOCK DIAGRAM

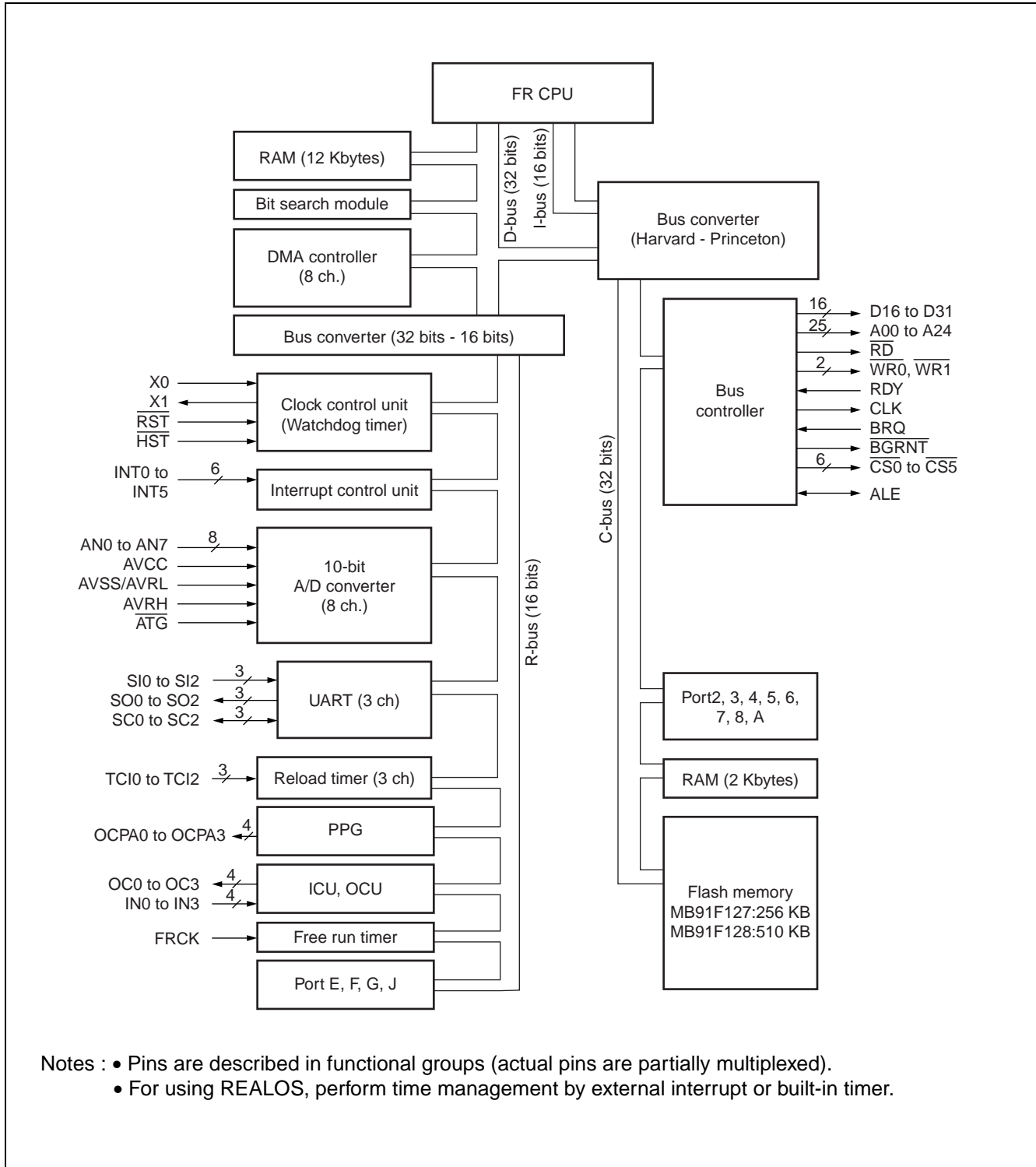

■ CPU CORE MEMORY SPACE

• MB91F127

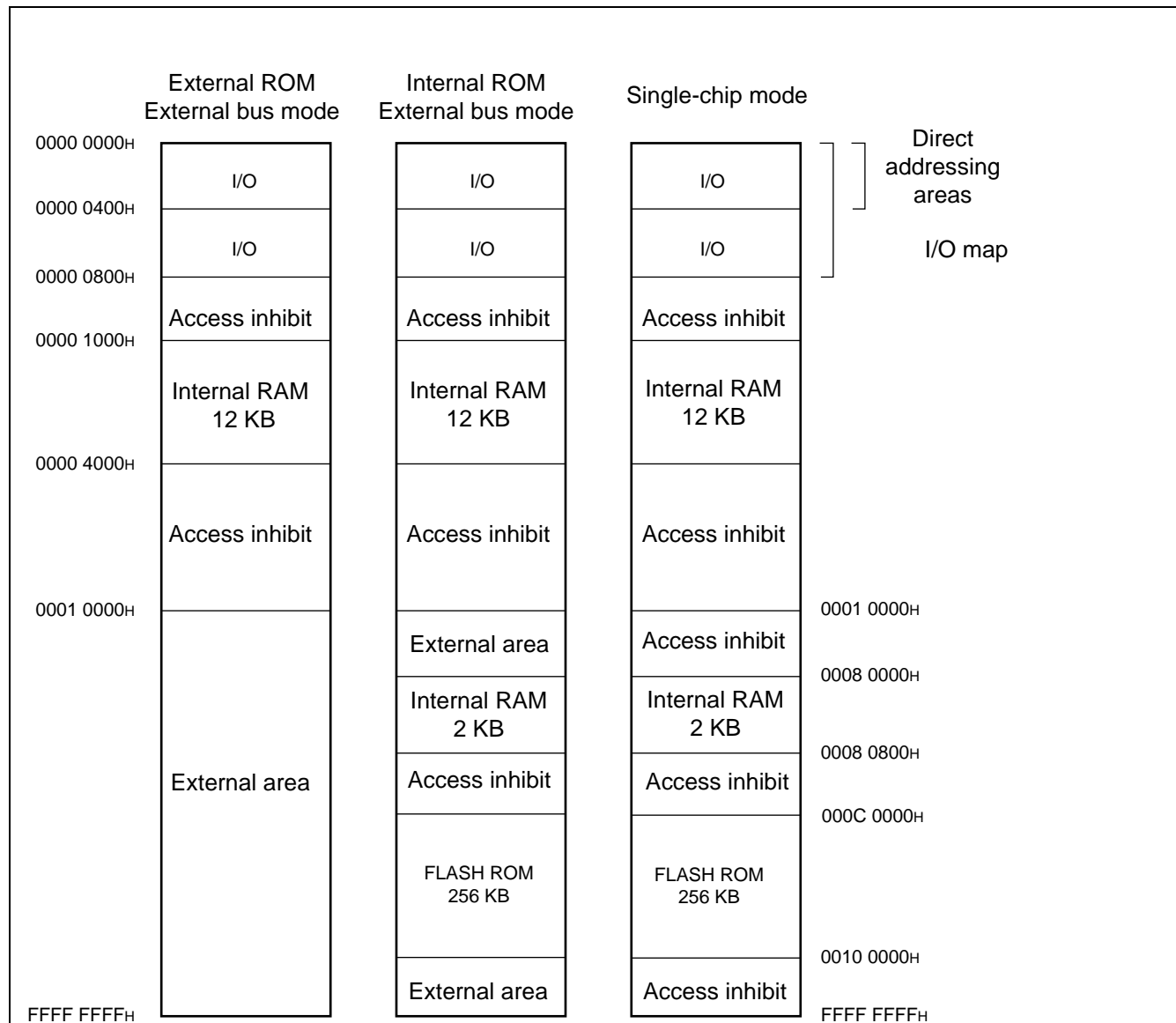

Note : External area is not accessible in single-chip mode. When accessing to external areas, select the internal ROM external bus mode in mode register.

Direct addressing areas

The areas described below are used for I/O processes. The areas, referred to as “direct addressing areas”, allow specifying an operand address directly by an instruction. The direct addressing areas varies as the following, depending on size of the data to be accessed.

- Byte-data access : 000H to 0FFH
- Half-word data access : 000H to 1FFH
- Word-data access : 000H to 3FFH

MB91129 Series

• MB91F128

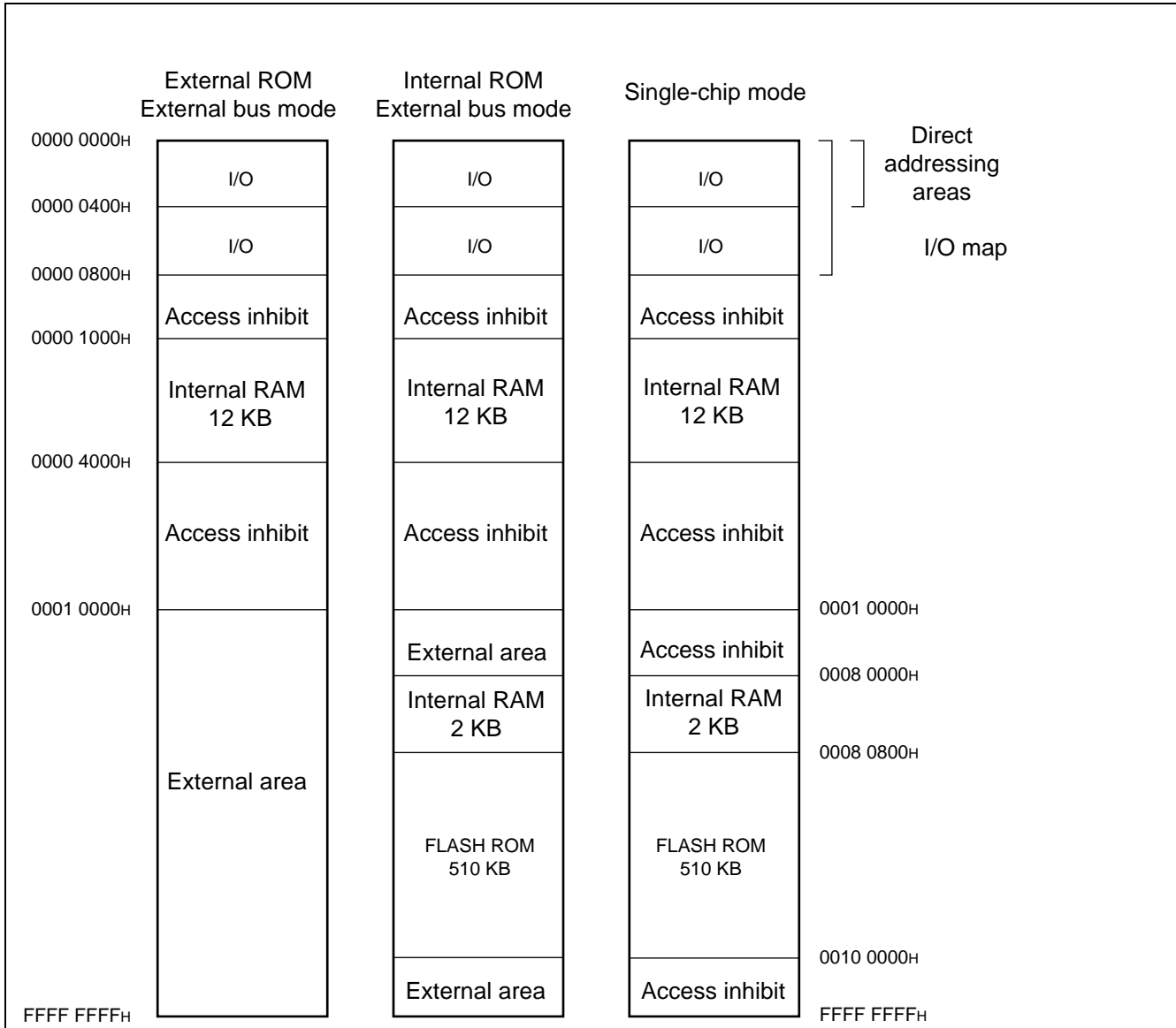

Note : External area is not accessible in single-chip mode. When accessing to external areas, select the internal ROM external bus mode in mode register.

Direct addressing areas

The areas described below are used for I/O processes. The areas, referred to as “direct addressing areas”, allow specifying an operand address directly by an instruction. The direct addressing areas varies as the following, depending on size of the data to be accessed.

- Byte-data access : 000H to 0FFH
- Half-word data access : 000H to 1FFH
- Word-data access : 000H to 3FFH

■ LEGEND OF I/O MAP

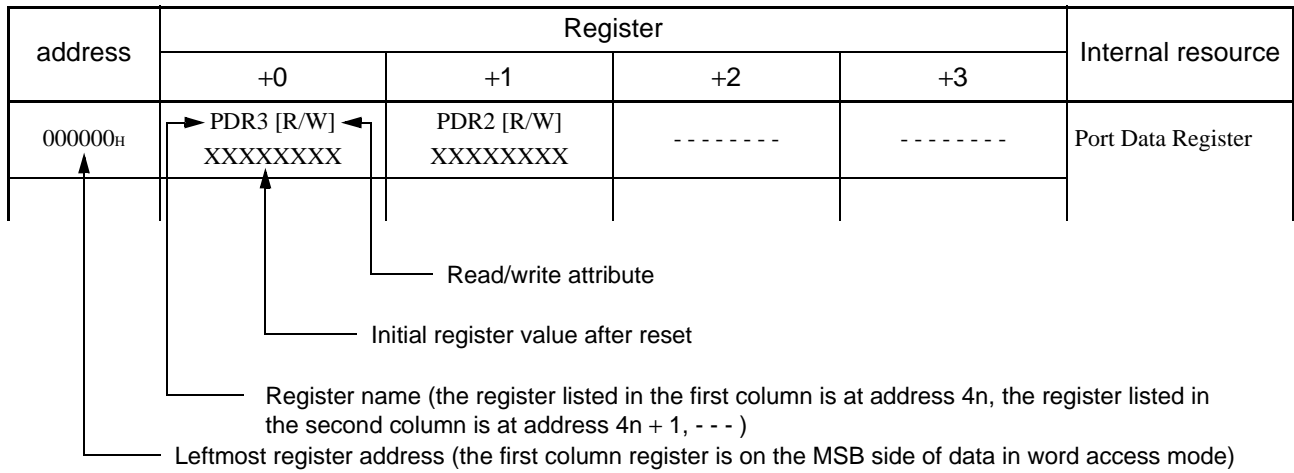

Note : Register bit values indicate initial values as shown below :

“1” : Initial value “1”

“0” : Initial value “0”

“X” : Initial value “X”

“-” : Register does not exist physically in this position.

MB91129 Series

■ I/O MAP

Address	Register				Internal resource
	+0	+1	+2	+3	
000000H	PDR3 [R/W] XXXXXXXX	PDR2 [R/W] XXXXXXXX	—	—	Port data Register
000004H	PDR7 [R/W] -----X	PDR6 [R/W] XXXXXXXX	PDR5 [R/W] XXXXXXXX	PDR4 [R/W] XXXXXXXX	
000008H	—	PDRA [R/W] XXXXXXXX	—	PDR8[R/W] -- XXXXXX	
00000CH	—				
000010H	—	—	PDRE [R/W] XXXXXXXX	PDRF [R/W] XXXXXXXX	
000014H	PDRG [R/W] XXXXXXXX	—	—	PDRJ [R/W] XXXXXXXX	
000018H	—	—	—	—	Reserved
00001CH	SSR [R/W] 00001- 00	SIDR [R/W] XXXXXXXX	SCR [R/W] 00000100	SMR [R/W] 00 - - 0 - 00	UART0
000020H	SSR [R/W] 00001- 00	SIDR [R/W] XXXXXXXX	SCR [R/W] 00000100	SMR [R/W] 00 - - 0 - 00	UART1
000024H	SSR [R/W] 00001- 00	SIDR [R/W] XXXXXXXX	SCR [R/W] 00000100	SMR [R/W] 00 - - 0 - 00	UART2
000028H	TMRLR [W] XXXXXXXX XXXXXXXX		TMR [W] XXXXXXXX XXXXXXXX		Reload Timer 0
00002CH	—		TMCSR [R/W] ---- 0000 00000000		
000030H	TMRLR [W] XXXXXXXX XXXXXXXX		TMR [W] XXXXXXXX XXXXXXXX		Reload Timer 1
000034H	—		TMCSR [R/W] ---- 0000 00000000		
000038H	—		—		Reserved
00003CH	TMRLR [W] XXXXXXXX XXXXXXXX		TMR [W] XXXXXXXX XXXXXXXX		Reload Timer 2
000040H	—		TMCSR [R/W] ---- 0000 00000000		
000044H	IPCP1[R] XXXXXXXX XXXXXXXX		IPCP0[R] XXXXXXXX XXXXXXXX		16 bit ICU
000048H	IPCP3[R] XXXXXXXX XXXXXXXX		IPCP2[R] XXXXXXXX XXXXXXXX		
00004CH	—	ICS23[R/W] 00000000	—	ICS01[R/W] 00000000	
000050H	ADCR [W] 00101-XX XXXXXXXX		ADCS [R/W] 00000000 00000000		A/D converter (Serially com- pared)

(Continued)

MB91129 Series

Address	Register				Internal resource
	+0	+1	+2	+3	
000054 _H	OCCP1[R/W] XXXXXXXX XXXXXXXX		OCCP0[R/W] XXXXXXXX XXXXXXXX		16 bit OCU
000058 _H	OCCP3[R/W] XXXXXXXX XXXXXXXX		OCCP2[R/W] XXXXXXXX XXXXXXXX		
00005C _H	—		—		Reserved
000060 _H	—		—		
000064 _H	OCS2, 3[R/W] XXX00000 0000XX00		OCS0, 1[R/W] XXX00000 0000XX00		16 bit OCU
000068 _H	—		—		Reserved
00006C _H	TCDT [R/W] 00000000 00000000		TCCS [R/W] 0 - - - - - 00000000		Free run timer
000070 _H	—		—		Reserved
000074 _H	—		—		Reserved
000078 _H	UTM/UTIMR [R/W] 00000000 00000000		—	UTIMC[R/W] 0 - - 00001	U-Timer0
00007C _H	UTM/UTIMR [R/W] 00000000 00000000		—	UTIMC[R/W] 0 - - 00001	U-Timer1
000080 _H	UTM/UTIMR [R/W] 00000000 00000000		—	UTIMC[R/W] 0 - - 00001	U-Timer2
000084 _H	—		—		Reserved
000088 _H	—		—		
00008C _H	—		—		Reserved
000090 _H	—		—		
000094 _H	EIRR [R/W] 00000000	ENIR [R/W] 00000000	—		External interrupt/ NMI
000098 _H	EHVR [R/W] - - - - 0000	ELVR [R/W] 00000000	—		

(Continued)

MB91129 Series

Address	Register				Internal resource
	+0	+1	+2	+3	
00009C _H	—				Reserved
0000A0 _H	—				
0000A4 _H	—				
0000A8 _H	—				
0000AC _H	—				
0000B0 _H	—				
0000B4 _H	—				
0000B8 _H	—				
0000BC _H	—				
0000C0 _H	—				
0000C4 _H	—				
0000C8 _H	—				
0000CC _H	—				
0000D0 _H	—	—	DDRE [W] 00000000	DDRF [W] 00000000	Port direction register
0000D4 _H	—	AIC3[W] 11111111	—	—	A/D converter
0000D8 _H	DDRG [W] 00000000	—	—	DDRJ [W] 00000000	Port direction register
0000DC _H	GCN1 [R/W] 00110010 00010000		—	GCN2[R/W] 00000000	PPG ctl
0000E0 _H	PTMR0 [R] 11111111 11111111		PCSR0 [W] XXXXXXXX XXXXXXXX		PPG0
0000E4 _H	PDUT0 [W] XXXXXXXX XXXXXXXX		PCNH0[R/W] 0000000 -	PCNL0[R/W] 00000000	
0000E8 _H	PTMR1 [R] 11111111 11111111		PCSR1 [W] XXXXXXXX XXXXXXXX		PPG1
0000EC _H	PDUT1 [W] XXXXXXXX XXXXXXXX		PCNH1[R/W] 0000000 -	PCNL1[R/W] 00000000	
0000F0 _H	PTMR2 [R] 11111111 11111111		PCSR2 [W] XXXXXXXX XXXXXXXX		PPG2
0000F4 _H	PDUT2 [W] XXXXXXXX XXXXXXXX		PCNH2[R/W] 0000000 -	PCNL2[R/W] 00000000	
0000F8 _H	PTMR3 [R] 11111111 11111111		PCSR3 [W] XXXXXXXX XXXXXXXX		PPG3
0000FC _H	PDUT3 [W] XXXXXXXX XXXXXXXX		PCNH3[R/W] 0000000 -	PCNL3[R/W] 00000000	

(Continued)

MB91129 Series

Address	Register				Internal resource
	+0	+1	+2	+3	
000100H to 0001FCH	—				Reserved
000200H	DPDP [R/W] ----- -0000000				DMAC
000204H	DACSR [R/W] 00000000 00000000 00000000 00000000				
000208H	DATCR [R/W] ----- --XX0000 --XX0000 --XX0000				
00020CH	—				
000210H to 0002FCH	—				Reserved
000300H to 0003ECH	—				Reserved
0003F0H	BSD0 [W] XXXXXXXX XXXXXXXX XXXXXXXX XXXXXXXX				Bit search module
0003F4 H	BSD1 [R/W] XXXXXXXX XXXXXXXX XXXXXXXX XXXXXXXX				
0003F8H	BSDC [W] XXXXXXXX XXXXXXXX XXXXXXXX XXXXXXXX				
0003FCH	BSRR [R/W] XXXXXXXX XXXXXXXX XXXXXXXX XXXXXXXX				

(Continued)

MB91129 Series

Address	Register				Internal resource
	+0	+1	+2	+3	
000400 _H	ICR00 [R/W] ---11111	ICR01[R/W] ---11111	ICR02[R/W] ---11111	ICR03[R/W] ---11111	Interrupt controller
000404 _H	ICR04[R/W] ---11111	ICR05[R/W] ---11111	ICR06[R/W] ---11111	ICR07[R/W] ---11111	
000408 _H	ICR08 [R/W] ---11111	ICR09[R/W] ---11111	ICR10[R/W] ---11111	ICR11[R/W] ---11111	
00040C _H	ICR12[R/W] ---11111	ICR13[R/W] ---11111	ICR14[R/W] ---11111	ICR15[R/W] ---11111	
000410 _H	ICR16[R/W] ---11111	ICR17[R/W] ---11111	ICR18[R/W] ---11111	ICR19[R/W] ---11111	
000414 _H	ICR20[R/W] ---11111	ICR21[R/W] ---11111	ICR22[R/W] ---11111	ICR23[R/W] ---11111	
000418 _H	ICR24 [R/W] ---11111	ICR25[R/W] ---11111	ICR26[R/W] ---11111	ICR27[R/W] ---11111	
00041C _H	ICR28[R/W] ---11111	ICR29[R/W] ---11111	ICR30[R/W] ---11111	ICR31[R/W] ---11111	
000420 _H	ICR32[R/W] ---11111	ICR33[R/W] ---11111	ICR34[R/W] ---11111	ICR35[R/W] ---11111	
000424 _H	ICR36[R/W] ---11111	ICR37[R/W] ---11111	ICR38[R/W] ---11111	ICR39[R/W] ---11111	
000428 _H	ICR40[R/W] ---11111	ICR41[R/W] ---11111	ICR42[R/W] ---11111	ICR43[R/W] ---11111	
00042C _H	ICR44[R/W] ---11111	ICR45[R/W] ---11111	ICR46[R/W] ---11111	ICR47[R/W] ---11111	
000430 _H	DICR [R/W] -----0	HRCL [R/W] ---11111	—	—	Delay interrupt
000434 _H to 00047C _H	—				Reserved
000480 _H	RSRR/WTCR [R/W] 1XXXX - 00	STCR [R/W] 000111--	PDDR [R/W] ---- 0000	CTBR [W] XXXXXXXX	Clock controller block
000484 _H	GCR [R/W] 110011 - 1	WPR [W] XXXXXXXX	—	—	
000488 _H	PTCR [R/W] 00 -- 0 ---	—			PLL controller block
00048C _H to 0005FC _H	—				Reserved

(Continued)

(Continued)

Address	Register				Internal resource
	+0	+1	+2	+3	
000600 _H	DDR3 [W] 00000000	DDR2 [W] 00000000	—	—	Data direction register
000604 _H	DDR7 [W] ----- 0	DDR6 [W] 00000000	DDR5 [W] 00000000	DDR4 [W] 00000000	
000608 _H	—	DDRA [W] -0000000	—	DDR8 [W] -- 000000	
00060C _H	ASR1 [W] 00000000 00000001		AMR1 [W] 00000000 00000000		External bus interface
000610 _H	ASR2 [W] 00000000 00000010		AMR2 [W] 00000000 00000000		
000614 _H	ASR3 [W] 00000000 00000011		AMR3 [W] 00000000 00000000		
000618 _H	ASR4 [W] 00000000 00000100		AMR4 [W] 00000000 00000000		
00061C _H	ASR5 [W] 00000000 00000101		AMR5 [W] 00000000 00000000		
000620 _H	AMD0 [R/W] --- XX111	AMD1 [R/W] 0 -- 00000	AMD32[R/W] 00000000	AMD4 [R/W] 0 -- 00000	
000624 _H	AMD5[R/W] 0 -- 00000	DSCR [W] 00000000	RFCR [R/W] --XXXXXX 00 --- 000		
000628 _H	EPCR0 [W] -- 1 - 1100 -1111111		EPCR1 [W] ----- 1 11111111		
00062C _H	DMCR4 [R/W] 00000000 0000000-		DMCR5 [R/W] 00000000 0000000-		
000630 _H to 0007BC _H	—				Reserved
0007C0 _H	FSTR [R/W] 000XXXX0	—	—	—	Flash memory
0007C4 _H to 0007F8 _H	—				Reserved
0007FC _H	—		LER [W] ----- 000	MODR [W] XXXXXXXXX	Little endian register mode register

Note : Do not issue RMW instructions to a register with write-only bit.
 RMW instructions (RMW : Read modify write)

AND Rj, @Ri OR Rj, @Ri EOR Rj, @Ri
 ANDH Rj, @Ri ORH Rj, @Ri EORH Rj, @Ri
 ANDB Rj, @Ri ORB Rj, @Ri EORB Rj, @Ri
 BANDL #u4, @Ri BORL #u4, @Ri BEORL #u4, @Ri
 BANDH #u4, @Ri BORH #u4, @Ri BEORH #u4, @Ri

Data in "Reserved" or "-" area is indefinite.

MB91129 Series

■ INTERRUPT CAUSES, INTERRUPT VECTORS AND INTERRUPT CONTROL REGISTER ALLOCATIONS

Interrupt causes	Interrupt number		Interrupt level		TBR default Address*2
	Decimal	Hexadecimal	Register*1	Offset	
Reset	0	00	—	3FC _H	000FFFFC _H
Reserved by system	1	01	—	3F8 _H	000FFFF8 _H
Reserved by system	2	02	—	3F4 _H	000FFFF4 _H
Reserved by system	3	03	—	3F0 _H	000FFFF0 _H
Reserved by system	4	04	—	3EC _H	000FFFE _C
Reserved by system	5	05	—	3E8 _H	000FFFE8 _H
Reserved by system	6	06	—	3E4 _H	000FFFE4 _H
Reserved by system	7	07	—	3E0 _H	000FFFE0 _H
Reserved by system	8	08	—	3DC _H	000FFFD _C
Reserved by system	9	09	—	3D8 _H	000FFFD8 _H
Reserved by system	10	0A	—	3D4 _H	000FFFD4 _H
Reserved by system	11	0B	—	3D0 _H	000FFFD0 _H
Reserved by system	12	0C	—	3CC _H	000FFFCC _H
Reserved by system	13	0D	—	3C8 _H	000FFFC8 _H
Undefined instruction exception	14	0E	—	3C4 _H	000FFFC4 _H
NMI request	15	0F	15 (F _H) fixed	3C0 _H	000FFFC0 _H
External interrupt 0	16	10	ICR00	3BC _H	000FFFBC _H
External interrupt 1	17	11	ICR01	3B8 _H	000FFFB8 _H
External interrupt 2	18	12	ICR02	3B4 _H	000FFFB4 _H
External interrupt 3	19	13	ICR03	3B0 _H	000FFFB0 _H
UART 0 reception complete	20	14	ICR04	3AC _H	000FFFAC _H
UART 1 reception complete	21	15	ICR05	3A8 _H	000FFF8 _H
UART 2 reception complete	22	16	ICR06	3A4 _H	000FFF4 _H
UART 0 transmission complete	23	17	ICR07	3A0 _H	000FFF0 _H
UART 1 transmission complete	24	18	ICR08	39C _H	000FFF9C _H
UART 2 transmission complete	25	19	ICR09	398 _H	000FFF98 _H

(Continued)

Interrupt causes	Interrupt number		Interrupt level		TBR default Address*2
	Decimal	Hexadecimal	Register*1	Offset	
DMAC 0 (end, error)	26	1A	ICR10	394 _H	000FFF94 _H
DMAC 1 (end, erro)	27	1B	ICR11	390 _H	000FFF90 _H
DMAC 2 (end, erro)	28	1C	ICR12	38C _H	000FFF8C _H
DMAC 3 (end, erro)	29	1D	ICR13	388 _H	000FFF88 _H
DMAC 4 (end, erro)	30	1E	ICR14	384 _H	000FFF84 _H
DMAC 5 (end, erro)	31	1F	ICR15	380 _H	000FFF80 _H
DMAC 6 (end, erro)	32	20	ICR16	37C _H	000FFF7C _H
DMAC 7 (end, erro)	33	21	ICR17	378 _H	000FFF78 _H
A/D (sequential type)	34	22	ICR18	374 _H	000FFF74 _H
Reload timer 0	35	23	ICR19	370 _H	000FFF70 _H
Reload timer 1	36	24	ICR20	36C _H	000FFF6C _H
Reload timer 2	37	25	ICR21	368 _H	000FFF68 _H
External interrupt 4	38	26	ICR22	364 _H	000FFF64 _H
External interrupt 5	39	27	ICR23	360 _H	000FFF60 _H
Reserved by system	40	28	ICR24	35C _H	000FFF5C _H
Reserved by system	41	29	ICR25	358 _H	000FFF58 _H
U-TIMER 0	42	2A	ICR26	354 _H	000FFF54 _H
U-TIMER 1	43	2B	ICR27	350 _H	000FFF50 _H
U-TIMER 2	44	2C	ICR28	34C _H	000FFF4C _H
FLASH memory	45	2D	ICR29	348 _H	000FFF48 _H
Reserved by system	46	2E	ICR30	344 _H	000FFF44 _H
Reserved by system	47	2F	ICR31	340 _H	000FFF40 _H
PPG0	48	30	ICR32	33C _H	000FFF3C _H
PPG1	49	31	ICR33	338 _H	000FFF38 _H
PPG2	50	32	ICR34	334 _H	000FFF34 _H
PPG3	51	33	ICR35	330 _H	000FFF30 _H
ICU0 (capture)	52	34	ICR36	32C _H	000FFF2C _H
ICU1 (capture)	53	35	ICR37	328 _H	000FFF28 _H
ICU2 (capture)	54	36	ICR38	324 _H	000FFF24 _H
ICU3 (capture)	55	37	ICR39	320 _H	000FFF20 _H

(Continued)

MB91129 Series

(Continued)

Interrupt causes	Interrupt number		Interrupt level		TBR default Address*2
	Decimal	Hexadecimal	Register*1	Offset	
OCU0 (match)	56	38	ICR40	31C _H	000FFF1C _H
OCU1 (match)	57	39	ICR41	318 _H	000FFF18 _H
OCU2 (match)	58	3A	ICR42	314 _H	000FFF14 _H
OCU3 (match)	59	3B	ICR43	310 _H	000FFF10 _H
Reserved by system	60	3C	ICR44	30C _H	000FFF0C _H
16 bit free-run timer	61	3D	ICR45	308 _H	000FFF08 _H
Reserved by system	62	3E	ICR46	304 _H	000FFF04 _H
Delay interrupt cause bit	63	3F	ICR47	300 _H	000FFF00 _H
Reserved by system (used by REALOS) *3	64	40	—	2FC _H	000FFEFC _H
Reserved by system (used by REALOS) *3	65	41	—	2F8 _H	000FFE8 _H
Used by INT	66 to 255	42 to FF	—	2F4 _H to 000 _H	000FEF4 _H to 000FFC00 _H

*1 : ICR specifies interrupt levels for interrupt requests, using the registers in interrupt controller.
ICR is provided for each interrupt request.

*2 : TBR is a register that indicates a head address of the vector table for EIT.
An address that is found by adding offset values defined by TBR and EIT cause, is a vector address.

*3 : If REALOS/FR is used, 40_H and 41_H interrupts are used for system code.

Information : An 1 Kbyte area starting with an address indicated by TBR is the vector area for EIT. Size of the area for one vector is 4 byte. Relation between a vector number and a vector address is as follows:

$$\begin{aligned} \text{vctadr} &= \text{TBR} + \text{vctofs} \\ &= \text{TBR} + (3\text{FC}_{\text{H}} - 4 \times \text{vct}) \end{aligned}$$

Vctadr Vector address, vctofs: Vector offset, vct: Vector number

■ ELECTRICAL CHARACTERISTICS

1. Absolute Maximum Ratings

($V_{SS} = AV_{SS} = 0\text{ V}$)

Parameter	Symbol	Rating		Unit	Remarks
		Min	Max		
Power supply voltage	V_{CC}	$V_{SS} - 0.3$	$V_{SS} + 4.0$	V	
Analog supply voltage	AV_{CC}	$V_{SS} - 0.3$	$V_{SS} + 4.0$	V	*1
Analog reference voltage	$AVRH$	$V_{SS} - 0.3$	$V_{SS} + 4.0$	V	*1
Input voltage	V_I	$V_{SS} - 0.3$	$V_{CC} + 0.3$	V	*5
Analog input voltage	V_{IA}	$V_{SS} - 0.3$	$AV_{CC} + 0.3$	V	
Output voltage	V_O	$V_{SS} - 0.3$	$V_{CC} + 0.3$	V	*5
Maximum clamp current	I_{CLAMP}	-2.0	+2.0	mA	*6
Total maximum clamp current	$\Sigma I_{CLAMP} $	—	20	mA	*6
“L” level maximum output current	I_{OL}	—	10	mA	*2
“L” level average output current	I_{OLAV}	—	4	mA	*3
“L” level maximum total output current	ΣI_{OL}	—	100	mA	
“L” level average total output current	ΣI_{OLAV}	—	50	mA	*4
“H” level maximum output current	I_{OH}	—	-10	mA	*2
“H” level average output current	I_{OHAV}	—	-4	mA	*3
“H” level maximum total output current	ΣI_{OH}	—	-50	mA	
“H” level average total output current	ΣI_{OHAV}	—	-20	mA	*4
Power consumption	P_d	—	500	mW	
Operating temperature	T_A	-30	+70	°C	
Storage temperature	T_{stg}	-55	+150	°C	

*1 : Care must be taken that AV_{CC} , $AVRH$ do not exceed $V_{CC} + 0.3\text{ V}$. Also, care must be taken that $AVRH$ do not exceed AV_{CC} .

*2 : Maximum output current defines a peak value of a specific pin.

*3 : Average output current defines a mean value of current flow within a period of 100 ms in a specific pin.

*4 : Average total output current defines a mean value of current flow within a period of 100 ms in all pins.

*5 : V_I and V_O must not exceed $V_{CC} + 0.3\text{ V}$. However, when restricting the maximum value of current that flows to or from input power by using some external parts, the I_{CLAMP} rating is applied instead of the V_I rating.

*6 : • Applicable to pins : D16 to D31, A00 to A24, \overline{RDY} , \overline{BGRNT} , \overline{BRQ} , \overline{RD} , $\overline{WR0}$, $\overline{WR1}$, $\overline{CS0}$ to $\overline{CS5}$, \overline{CLK} , $\overline{OCPA0}$ to $\overline{OCPA3}$, $\overline{OC0}$ to $\overline{OC3}$, \overline{ALE} , $\overline{INT0}$ to $\overline{INT5}$, $\overline{SI0}$, $\overline{SI2}$, $\overline{SO0}$, $\overline{SO2}$, $\overline{TCI0}$, $\overline{SC2}$

- Use within recommended operating conditions.
- Use at DC voltage (current) .

(Continued)

MB91129 Series

(Continued)

- The +B signal should always be applied with a limiting resistance placed between the +B signal and the microcontroller.
- The value of the limiting resistance should be set so that when the signal is applied the input current to the microcontroller pins does not exceed rated values, either instantaneously or for prolonged periods.
- Note that when the microcontroller drive current is low, such as in the power saving modes, the +B input potential may pass through the protective diode and increase the potential at the VCC pin, and this may affect other devices.
- Note that if a +B signal is input when the microcontroller power supply is off (not fixed at 0 V), the power supply is provided from the pins, so that incomplete operation may result.
- Note that if the +B input is applied during power-on, the power supply is provided from the pins and the resulting supply voltage may not be sufficient to operate the power-on reset.
- Care must be taken not to leave the input pin open.
- Sample recommended circuits

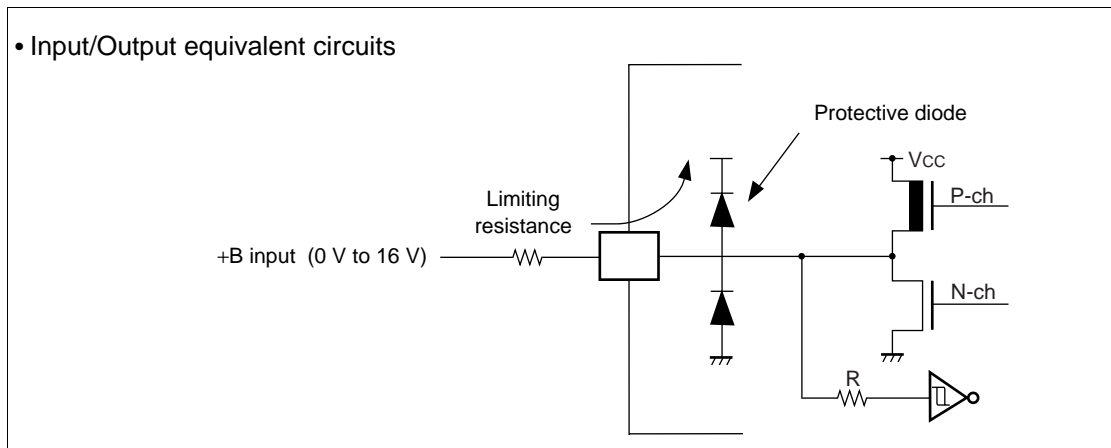

WARNING: Semiconductor devices can be permanently damaged by application of stress (voltage, current, temperature, etc.) in excess of absolute maximum ratings. Do not exceed these ratings.

2. Recommended Operating Conditions

($V_{SS} = AV_{SS} = 0\text{ V}$)

Parameter	Symbol	Value		Unit	Remarks
		Min	Max		
Power supply	V_{CC}	3.0	3.6	V	Normal operation
		2.0	3.6		Retain RAM data under "stop" condition
Analog supply voltage	AV_{CC}	$V_{SS} - 0.3$	$V_{SS} + 3.6$	V	
Analog reference voltage	AV_{RH}	AV_{SS}	AV_{CC}	V	
Operating temperature	T_A	-30	+70	°C	

WARNING: The recommended operating conditions are required in order to ensure the normal operation of the semiconductor device. All of the device's electrical characteristics are warranted when the device is operated within these ranges.

Always use semiconductor devices within their recommended operating condition ranges. Operation outside these ranges may adversely affect reliability and could result in device failure.

No warranty is made with respect to uses, operating conditions, or combinations not represented on the data sheet. Users considering application outside the listed conditions are advised to contact their representatives beforehand.

MB91129 Series

3. DC Characteristics

($AV_{CC} = V_{CC} = 3.3 \text{ V} \pm 0.3 \text{ V}$, $AV_{SS} = V_{SS} = 0 \text{ V}$, $T_A = -30 \text{ }^\circ\text{C}$ to $+70 \text{ }^\circ\text{C}$)

Parameter	Symbol	Pin name	Condition	Value			Unit	Remarks
				Min	Typ	Max		
"H" level input voltage	V_{IHS}	Hysteresis input pin	—	$0.8 \times V_{CC}$	—	$V_{CC} + 0.3$	V	*
"L" level input voltage	V_{ILS}	Hysteresis input pin	—	$V_{SS} - 0.3$	—	$0.2 \times V_{CC}$	V	*
"H" level output voltage	V_{OH}	Port2 to PortJ	$V_{CC} = 3.3 \text{ V}$ $I_{OH} = -4.0 \text{ mA}$	$V_{CC} - 0.5$	—	—	V	
"L" level output voltage	V_{OL}	Port2 to PortJ	$V_{CC} = 3.3 \text{ V}$ $I_{OL} = 4.0 \text{ mA}$	—	—	0.4	V	
Input leak current	I_{LI}	Port2 to PortJ	$V_{CC} = 3.6 \text{ V}$ $V_{SS} < V_I < V_{CC}$	—	—	± 5	μA	
Power supply current	I_{CC}	VCC	25 MHz $V_{CC} = 3.3 \text{ V}$	—	75	100	mA	
	I_{CC}		25 MHz $V_{CC} = 3.3 \text{ V}$	—	85	120	mA	FLASH writing
	I_{CCS}		25 MHz $V_{CC} = 3.3 \text{ V}$	—	60	85	mA	Sleeping
	I_{CCH}		$T_A = 25 \text{ }^\circ\text{C}$ $V_{CC} = 3.3 \text{ V}$	—	10	150	μA	Stopping
Input capacity	C_{IN}	Other than AVCC, AVSS, AVRH, VCC, VSS	—	—	10	—	pF	

* : Refer to "■ INPUT/OUTPUT CIRCUIT TYPE".

4. AC Characteristics

(1) Clock Timing

($V_{CC} = 3.3 \text{ V} \pm 0.3 \text{ V}$, $AV_{SS} = V_{SS} = 0 \text{ V}$, $T_A = -30 \text{ }^\circ\text{C}$ to $+70 \text{ }^\circ\text{C}$)

Parameter	Symbol	Condition	Value		Unit	Remarks	
			Min	Max			
Clock frequency (High speed, automatic oscillation)	f _c	—	10	25	MHz	Self oscillation allowable range	
Clock frequency (High speed, PLL used)			10	25	MHz	PLL-use allowable area for self oscillation and external clock input *1	
Clock frequency (High speed, 1/2 division input)			10	25	MHz	External clock input allowable range	
Clock cycle time			t _c	40	100	ns	
Frequency regulation (when locked)			Δf	—	10	%	*2
Input clock pulse width	P _{WH} , P _{WL}	—	9.5	—	ns		
Input clock rise and fall time	t _{CR} t _{CF}	—	—	8	ns	(t _{CR} + t _{CF})	
Internal operation clock frequency	CPU system	f _{CP}	0.625 *3	25	MHz		
	Peripheral system	f _{CPP}	0.625 *3	25	MHz		
Internal operation clock cycle time	CPU system	t _{CP}	40	1600 *3	ns		
	Peripheral system	t _{LCPP}	40	1600 *3	ns		

*1 : Although PLL allows selection among x1 and x2 multiplication modes, the selection is limited by oscillation frequency as follows:

Specifying "x2 multiplication" is not allowed if oscillation frequency exceeds 12.5 MHz.

*2 : Frequency regulation indicates a maximum fluctuation from a specified center frequency under locked frequency multiplication.

$$\Delta f = \frac{|\alpha|}{f_0} \times 100 (\%)$$

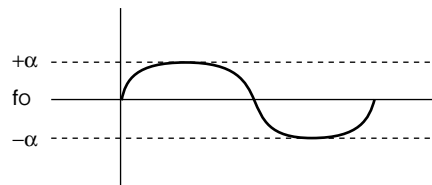

MB91129 Series

*3 : This is a value in the case where 10 MHz signal, a minimum value of clock frequency, is input to X0 and where 1/2-division in oscillation circuit and 1/8-gear are used.

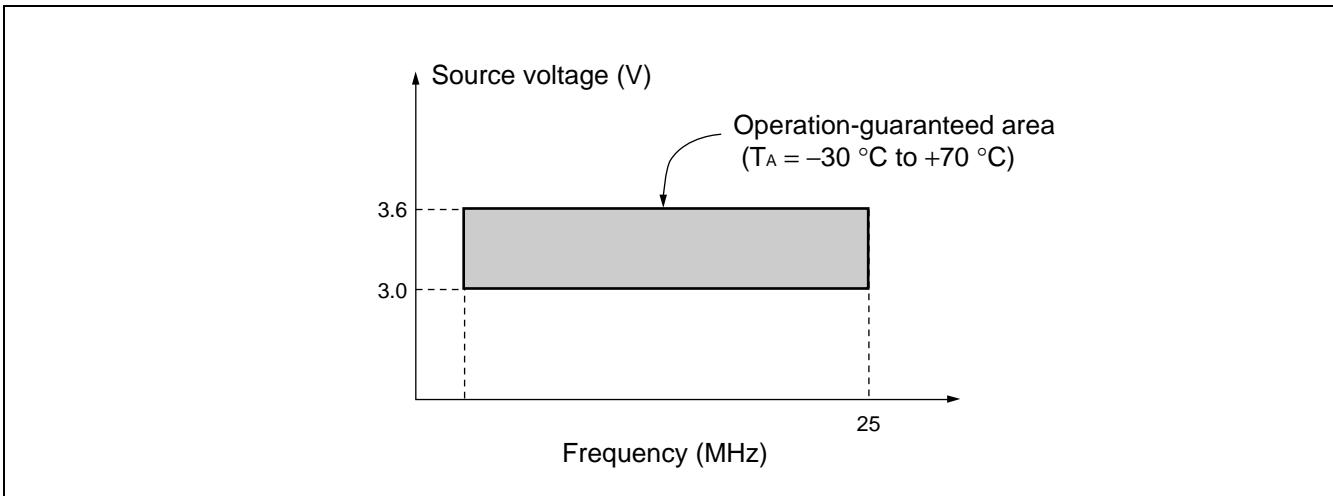
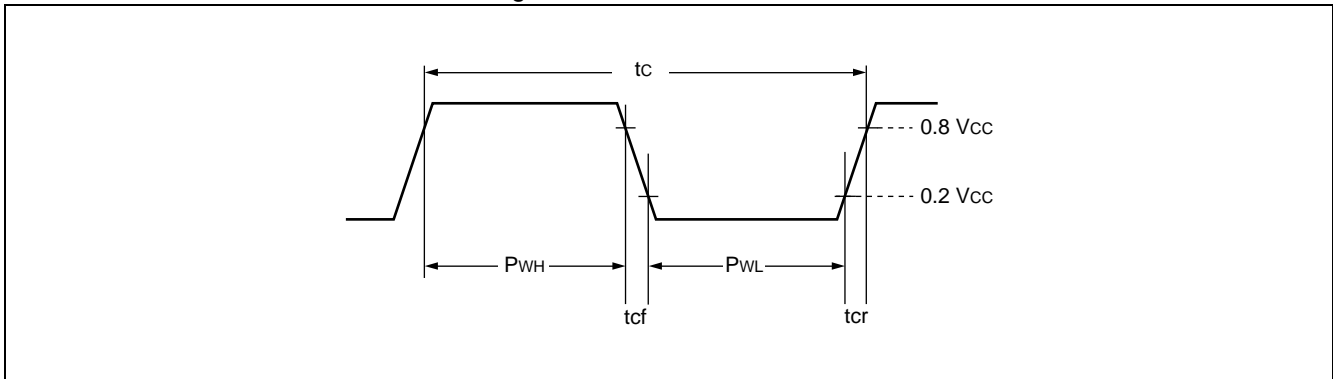

(2) Clock Output Timing

($V_{CC} = 3.3\text{ V} \pm 0.3\text{ V}$, $AV_{SS} = V_{SS} = 0\text{ V}$, $T_A = -30\text{ }^\circ\text{C}$ to $+70\text{ }^\circ\text{C}$)

Parameter	Symbol	Pin name	Condition	Value		Unit	Remarks
				Min	Max		
Cycle time	t_{CYC}	CLK	—	t_{CP}	—	ns	*1
CLK \uparrow → CLK \downarrow	t_{CHCL}	CLK		$1/2 \times t_{CYC} - 10$	$1/2 \times t_{CYC} + 10$	ns	*2
CLK \downarrow → CLK \uparrow	t_{CLCH}	CLK		$1/2 \times t_{CYC} - 10$	$1/2 \times t_{CYC} + 10$	ns	*3

*1 : t_{CYC} is a frequency of 1 clock cycle indicating gear cycle.

*2 : The values indicate specifications where x1 gear cycle is used.

If gear cycle of 1/2, 1/4, or 1/8 is specified, calculate in the formula below by substituting 1/2, 1/4, or 1/8 into n.

$$\text{Min : } (1 - n / 2) \times t_{CYC} - 10$$

$$\text{Max : } (1 - n / 2) \times t_{CYC} + 10$$

*3 : The values indicate specifications where x1 gear cycle is used.

If gear cycle of 1/2, 1/4, or 1/8 is specified, calculate in the formula below by substituting 1/2, 1/4, or 1/8 into n.

$$\text{Min : } n / 2 \times t_{CYC} - 10$$

$$\text{Max : } n / 2 \times t_{CYC} + 10$$

Clock output timing

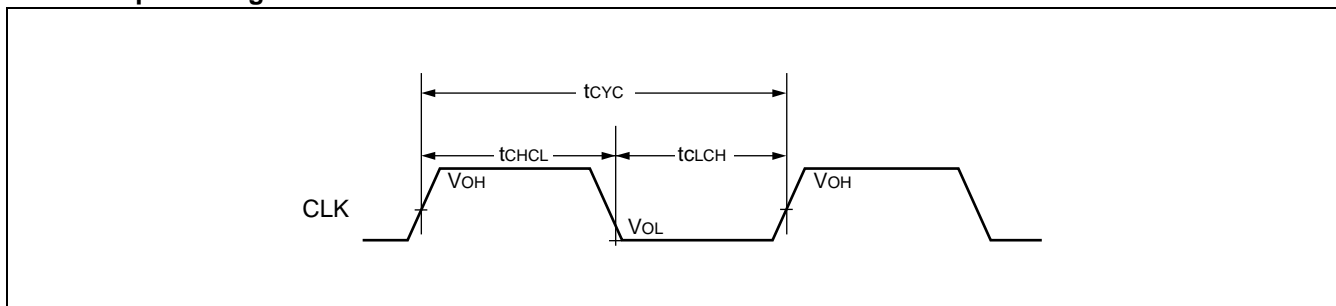

(3) Reset Input

($V_{CC} = 3.3\text{ V} \pm 0.3\text{ V}$, $AV_{SS} = V_{SS} = 0\text{ V}$, $T_A = -30\text{ }^\circ\text{C}$ to $+70\text{ }^\circ\text{C}$)

Parameter	Symbol	Pin name	Condition	Value		Unit	Remarks
				Min	Max		
Reset input time	t_{RSTL}	$\overline{\text{RST}}$	—	$t_{CP} \times 5$	—	ns	

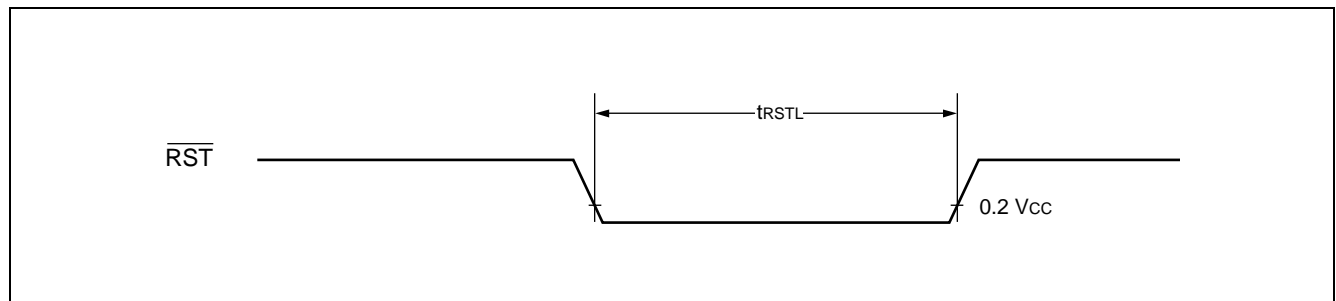

MB91129 Series

(4) Power-on Reset

($V_{CC} = 3.3 \text{ V} \pm 0.3 \text{ V}$, $V_{SS} = 0 \text{ V}$, $T_A = -30 \text{ }^\circ\text{C}$ to $+70 \text{ }^\circ\text{C}$)

Parameter	Symbol	Pin name	Condition	Value		Unit	Remarks
				Min	Max		
Power supply rise time	t_R	VCC	$V_{CC} = 3.3 \text{ V}$	—	20	ms	$V_{CC} < 0.2 \text{ V}$ before turning on power
Power supply shut off time	t_{OFF}	VCC	—	2	—	ms	
Oscillation stabilizing wait time	t_{OSC}	—	—	$2 \times t_c \times 2^{21} + 100 \mu\text{s}$	—	ns	

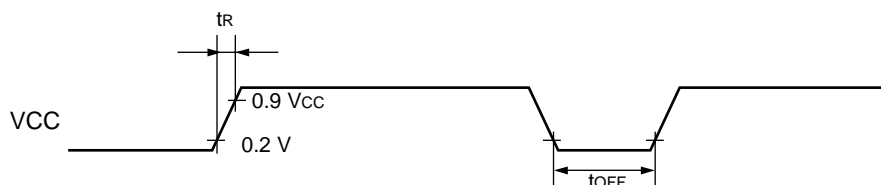

A sudden change of supply voltage may activate the power-on reset function. It is recommended that power voltage should be changed smoothly with less fluctuation of voltages.

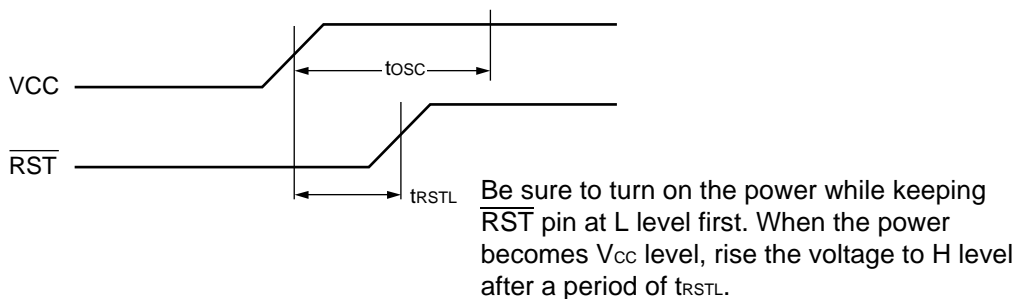
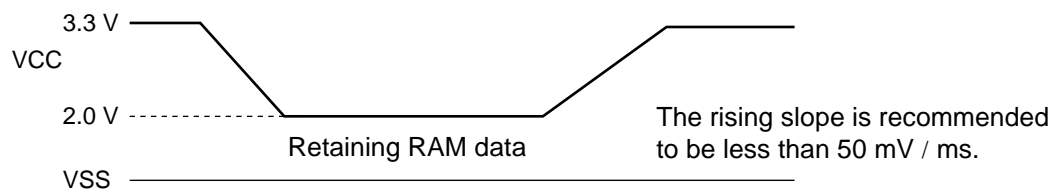

(5) Normal Bus Access Read/Write Operation

($V_{CC} = 3.3\text{ V} \pm 0.3\text{ V}$, $V_{SS} = 0\text{ V}$, $T_A = -30\text{ }^\circ\text{C}$ to $+70\text{ }^\circ\text{C}$)

Parameter	Symbol	Pin name	Condition	Value		Unit	Remarks
				Min	Max		
CS0 to CS5 delay time	t_{CHCSL}	CLK	—	—	15	ns	
CS0 to CS5 delay time	t_{CHCSH}	$\overline{CS0}$ to $\overline{CS5}$		—	15	ns	
Address delay time	t_{CHAV}	CLK A24 to A00		—	15	ns	
Data delay time	t_{CHDV}	CLK D31 to D16		—	15	ns	
\overline{RD} delay time	$t_{CLR L}$	CLK \overline{RD}		—	15	ns	
\overline{RD} delay time	$t_{CLR H}$			—	15	ns	
$\overline{WR0}, \overline{1}$ delay time	t_{CLWL}	CLK $\overline{WR0}, \overline{1}$		—	15	ns	
$\overline{WR0}, \overline{1}$ delay time	t_{CLWH}			—	15	ns	
Valid address→ Valid data input time	t_{AVDV}	A24 to A00 D31 to D16		—	$3/2 \times t_{cyc} - 25$	ns	*1 *2
$\overline{RD}\downarrow\rightarrow$ Valid data input time	t_{RLDV}	\overline{RD} D31 to D16		—	$t_{cyc} - 25$	ns	*1
Data setup → $\overline{RD}\uparrow$ Time	t_{DSRH}			25	—	ns	
$\overline{RD}\uparrow\rightarrow$ Data hold time	t_{RHDX}			0	—	ns	

*1 : If the bus is expanded by automatic wait insertion or RDY input, add time ($t_{cyc} \times$ the number of expanded cycles) to the rated value.

*2 : The ratings are based on conditions with “gear cycle $\times 1$ ”. If gear cycle of 1/2, 1/4, or 1/8 is specified, calculate in the formula below by substituting 1/2, 1/4, or 1/8 into n.

Formula : $(2 - n / 2) \times t_{cyc} - 25$

MB91129 Series

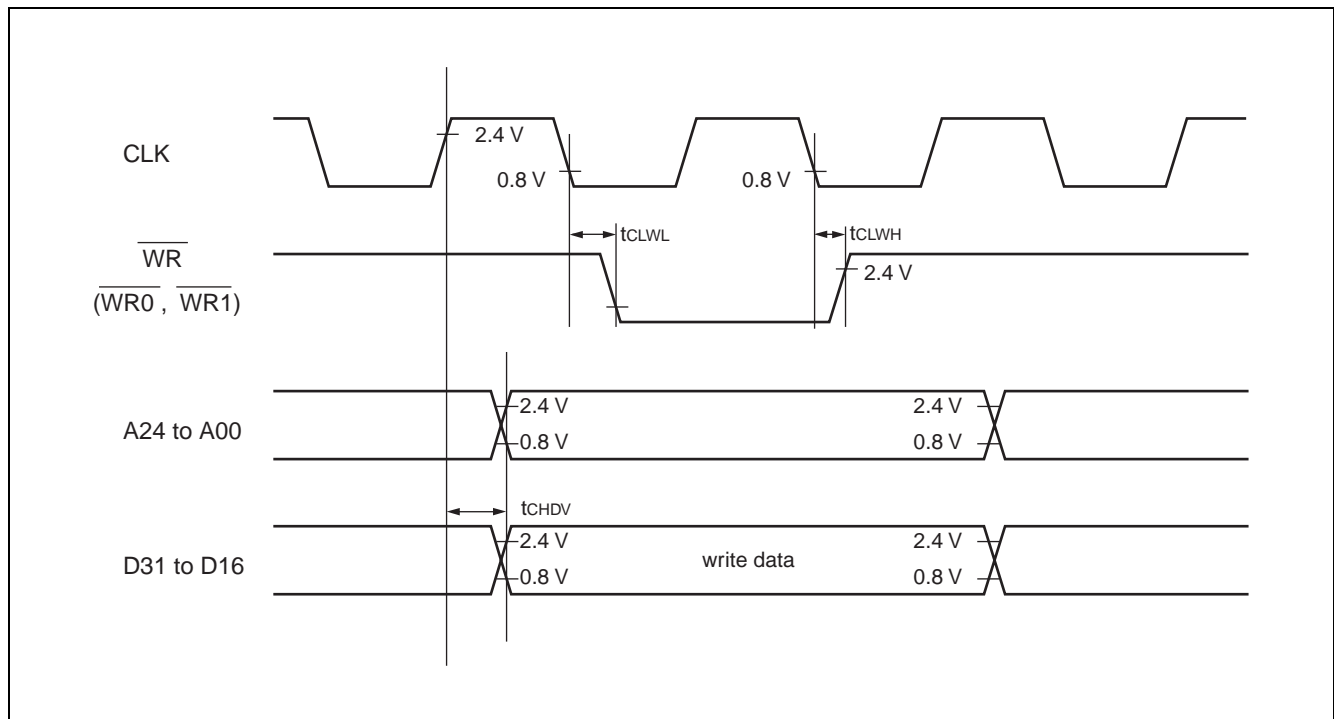
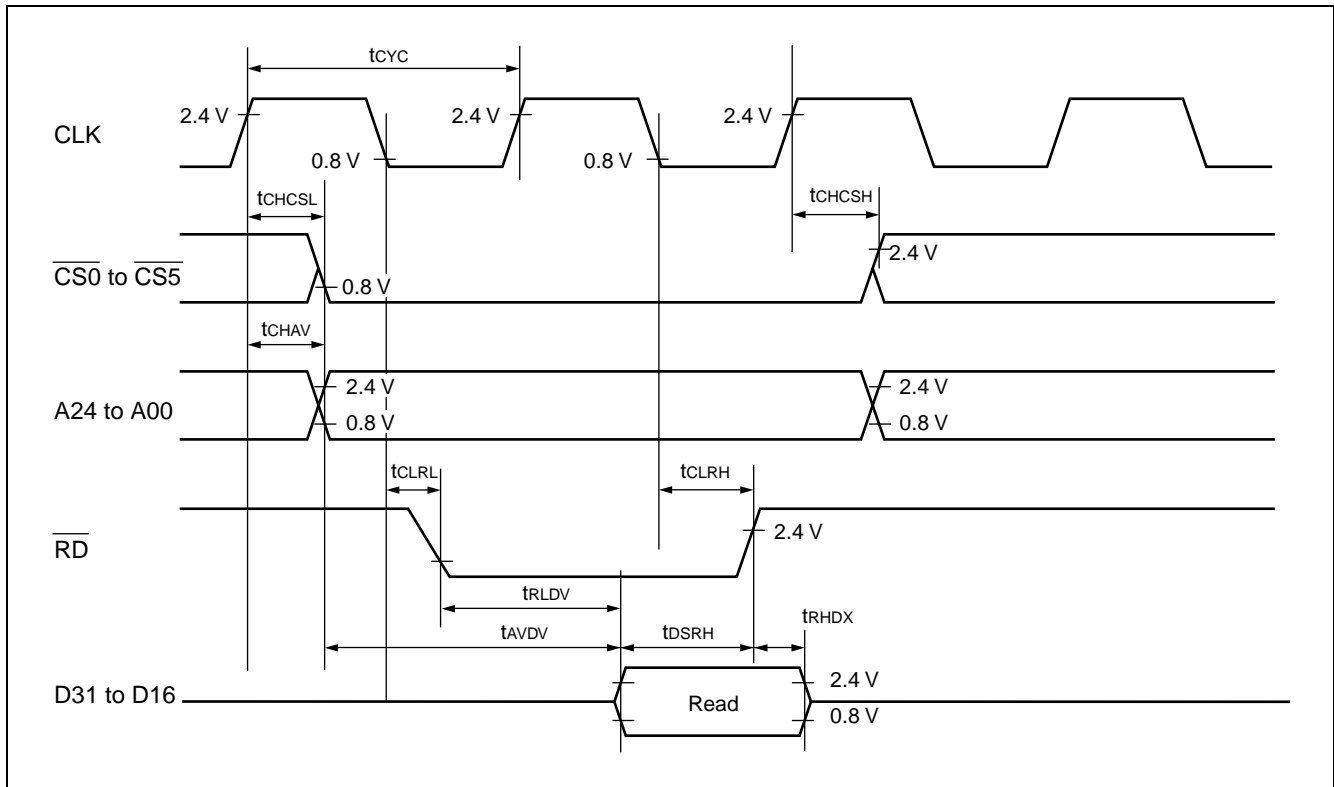

(6) Timeshared Bus Access Read/Write Operations

($V_{CC} = 3.3\text{ V} \pm 0.3\text{ V}$, $V_{SS} = 0\text{ V}$, $T_A = -30\text{ }^\circ\text{C}$ to $+70\text{ }^\circ\text{C}$)

Parameter	Symbol	Pin name	Condition	Value		Unit	Remarks
				Min	Max		
ALE delay time	t_{CLLH2}	CLK	—	—	10	—	
ALE delay time	t_{CLLL2}	ALE		—	10	—	
$\overline{\text{CS}}1$ delay time	t_{CHCSL2}	CLK		—	15	—	
$\overline{\text{CS}}1$ delay time	t_{CHCSH2}	$\overline{\text{CS}}1$		—	15	ns	
Address delay time	t_{CHAV2}	CLK		—	15	ns	
Data delay time	t_{CHDV2}	D31 to D16		—	15	ns	
$\overline{\text{RD}}$ delay time	t_{CLRL2}	CLK		—	10	ns	
$\overline{\text{RD}}$ delay time	t_{CLRH2}	$\overline{\text{RD}}$		—	10	ns	
$\overline{\text{WR}}0$, $\overline{\text{WR}}1$ delay time	t_{CLWL2}	CLK		—	10	ns	
$\overline{\text{WR}}0$, $\overline{\text{WR}}1$ pulse width	t_{CLWH2}	$\overline{\text{WR}}0$ $\overline{\text{WR}}1$		—	10	ns	
$\overline{\text{RD}}\downarrow\rightarrow$ Valid data input time	t_{RLDV2}	$\overline{\text{RD}}$ D31 to D16		—	$t_{cyc} - 25$	—	*
Data setup $\rightarrow\overline{\text{RD}}\uparrow$ time	t_{DSRH2}			25	—	ns	
$\overline{\text{RD}}\uparrow\rightarrow$ Data hold time	t_{RHDX2}			0	—	ns	

* : If the bus is expanded by automatic wait insertion or RDY input, add time ($t_{cyc} \times$ the number of expanded cycles) to the rated value.

MB91129 Series

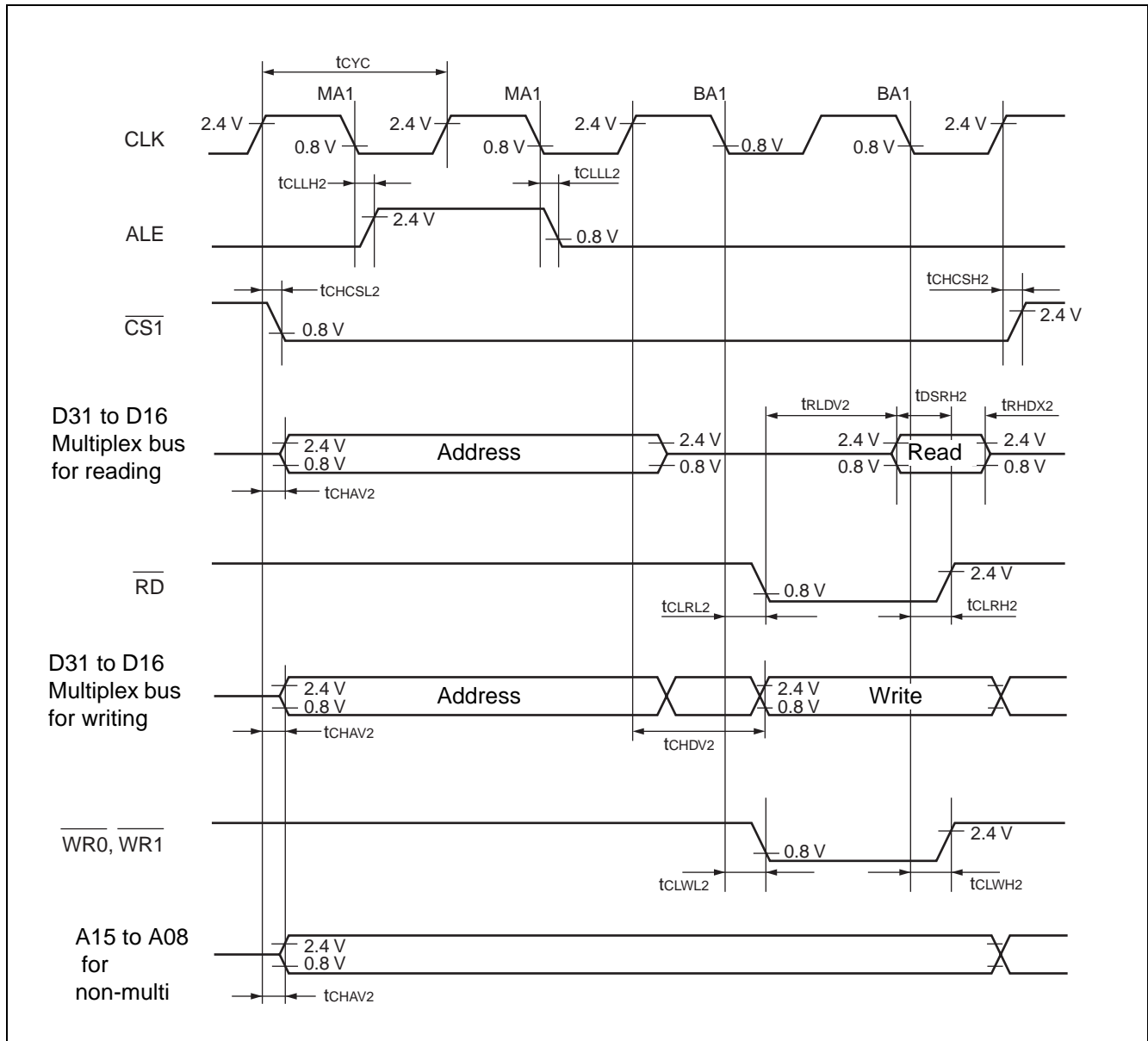

(7) Ready Input Timing

($V_{CC} = 3.3\text{ V} \pm 0.3\text{ V}$, $AV_{SS} = V_{SS} = 0\text{ V}$, $T_A = -30\text{ }^{\circ}\text{C}$ to $+70\text{ }^{\circ}\text{C}$)

Parameter	Symbol	Pin name	Condition	Value		Unit	Remarks
				Min	Max		
RDY setup time CLK↓	t_{RDYS}	RDY CLK	—	15	—	ns	
CLK↓→ RDY hold time	t_{RDYH}	CLK RDY		0	—	ns	

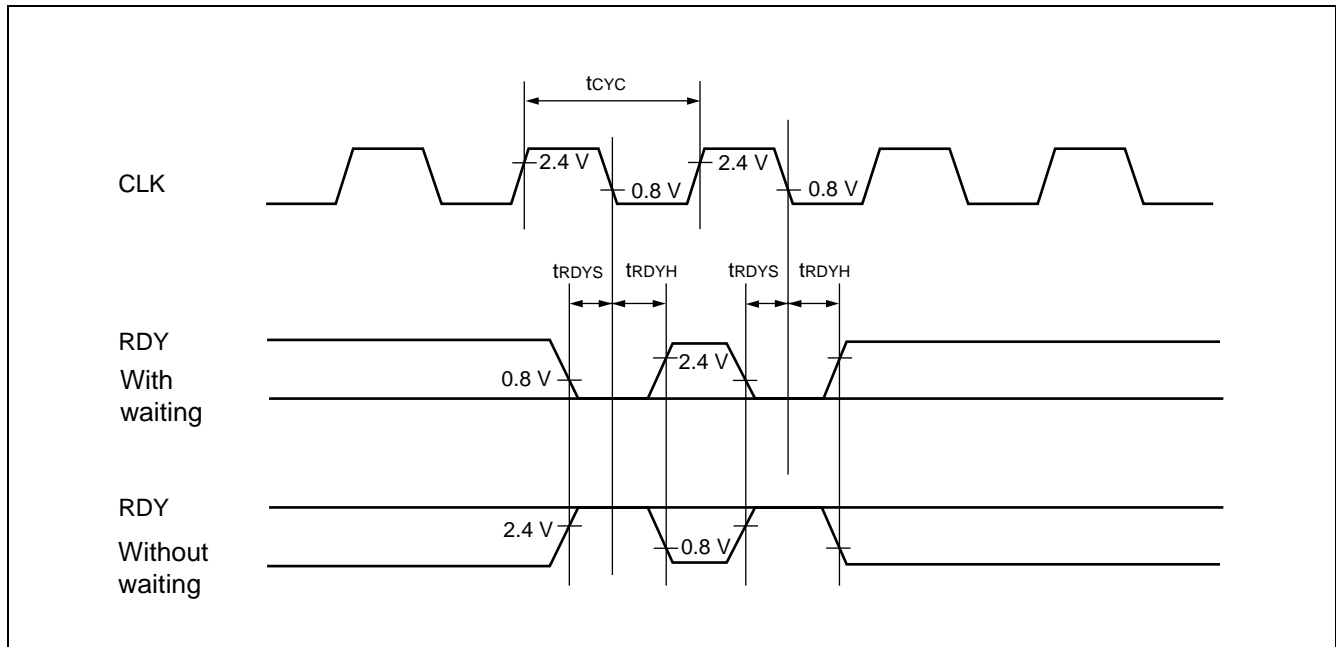

MB91129 Series

(8) Hold Timing

($V_{CC} = 3.0\text{ V} \pm 0.3\text{ V}$, $AV_{SS} = V_{SS} = 0\text{ V}$, $T_A = -30\text{ }^{\circ}\text{C}$ to $+70\text{ }^{\circ}\text{C}$)

Parameter	Symbol	Pin name	Condition	Value		Unit	Remarks
				Min	Max		
BGRNT $\bar{}$ delay time	t_{CHBGL}	CLK BGRNT $\bar{}$	—	—	10	ns	
BGRNT $\bar{}$ delay time	t_{CHBGH}			—	10	ns	
Signal floating →BGRNT $\bar{}$ ↓ time	t_{XHAL}	BGRNT $\bar{}$		$t_{CYC} - 10$	$t_{CYC} + 10$	ns	
BGRNT $\bar{}$ ↑ →Signal valid time	t_{HAHV}			$t_{CYC} - 10$	$t_{CYC} + 10$	ns	

Note : More than one cycle is required for BGRNT $\bar{}$ to change after BRQ is input.

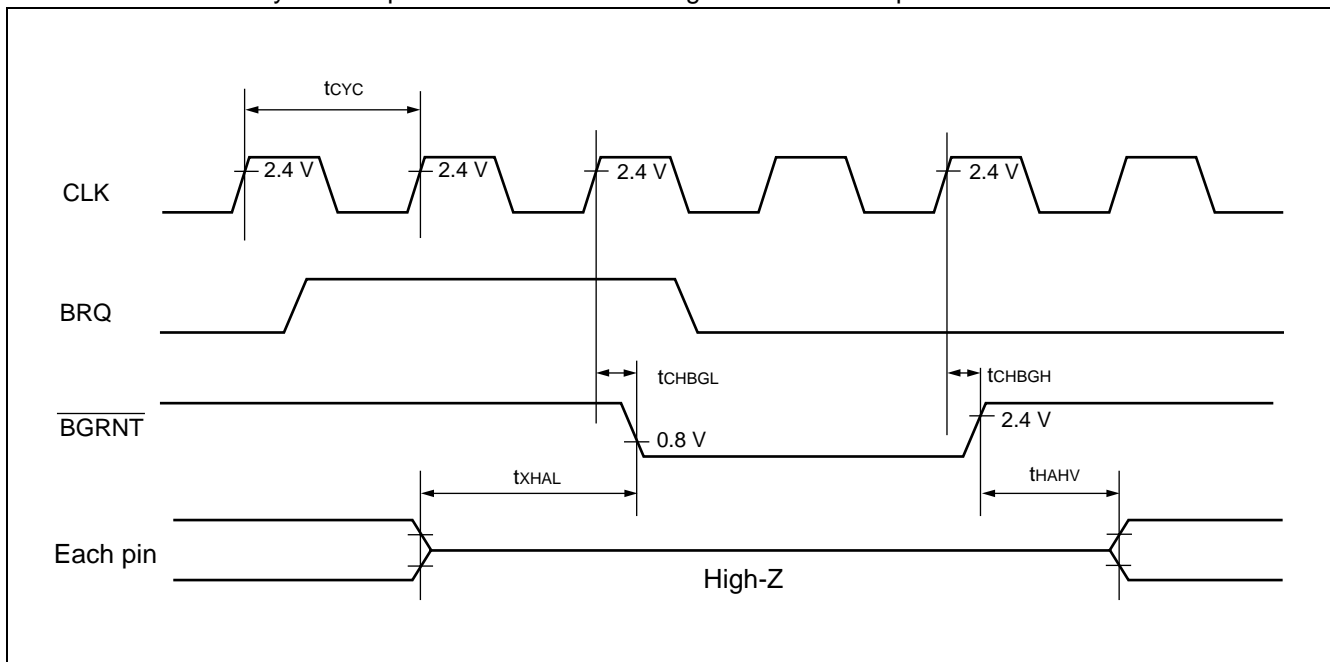

(9) UART Timing

($V_{CC} = 3.3\text{ V} \pm 0.3\text{ V}$, $V_{SS} = 0\text{ V}$, $T_A = -30\text{ }^\circ\text{C}$ to $+70\text{ }^\circ\text{C}$)

Parameter	Symbol	Pin name	Condition	Value		Unit	Remarks
				Min	Max		
Serial clock cycle time	t_{SCYC}	—	Internal shift clock mode	$8 t_{CYCP}^*$	—	ns	
SC \downarrow \rightarrow SO delay time	t_{SLOV}	—		-10	+50	ns	
Valid SI \rightarrow SC \uparrow	t_{IVSH}	—		50	—	ns	
SC \uparrow \rightarrow Valid SI hold time	t_{SHIX}	—		50	—	ns	
Serial clock "H" pulse width	t_{SHSL}	—	External shift clock mode	$4 t_{CYCP}^* - 10$	—	ns	
Serial clock "L" pulse width	t_{LSLH}	—		$4 t_{CYCP}^* - 10$	—	ns	
SC \downarrow \rightarrow SO delay time	t_{SLOV}	—		0	50	ns	
Valid SI \rightarrow SC \uparrow	t_{IVSH}	—		50	—	ns	
SC \uparrow \rightarrow Valid SI hold time	t_{SHIX}	—		50	—	ns	
Serial busy time	t_{BUSY}	—		—	$6 t_{CYCP}^*$	ns	
CS \downarrow \rightarrow SC, SO delay time	t_{CLZO}	—		—	50	ns	
CS \downarrow \rightarrow SC input mask time	t_{CLSL}	—		—	$3 t_{CYCP}^*$	ns	
SC \uparrow \rightarrow SC, SO Hi-Z time	t_{CHOZ}	—	—	50	ns		

* : t_{CYCP} is a cycle time of peripheral system clock.

Internal shift clock mode

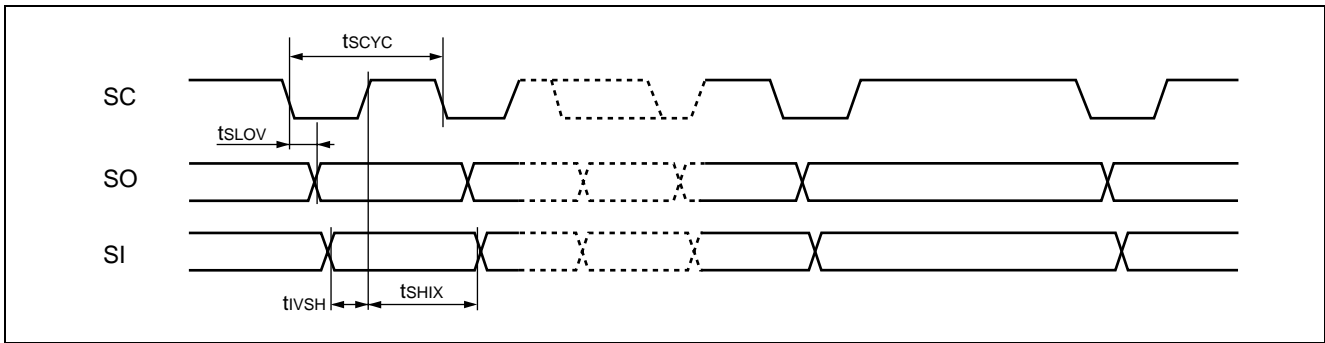

External shift clock mode

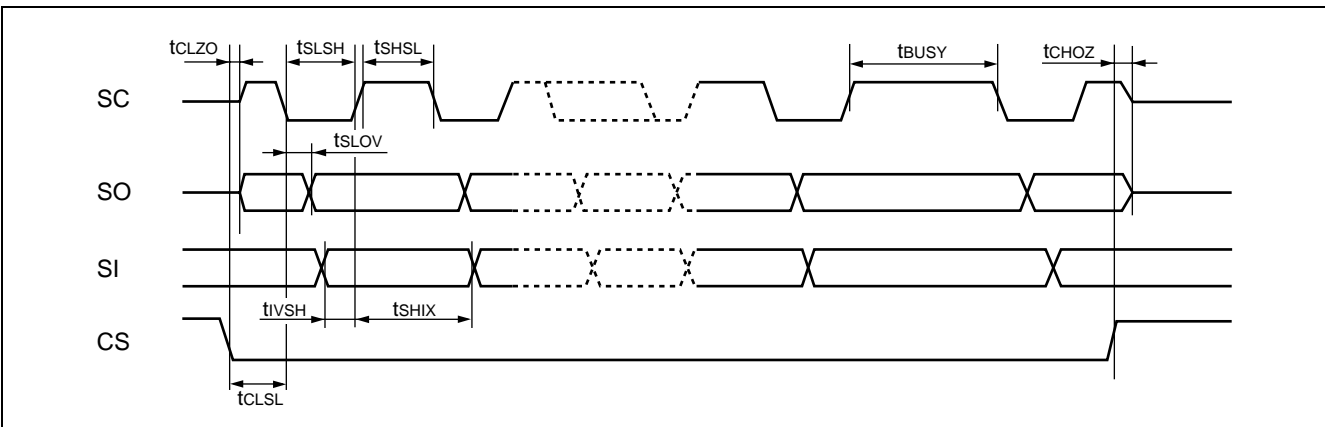

MB91129 Series

(10) Trigger Input Timing

($V_{CC} = 3.3\text{ V} \pm 0.3\text{ V}$, $V_{SS} = 0\text{ V}$, $T_A = -30\text{ }^\circ\text{C}$ to $+70\text{ }^\circ\text{C}$)

Parameter	Symbol	Pin name	Condition	Value		Unit	Remarks
				Min	Max		
Input pulse width	t_{TRGH} t_{TRGL}	\overline{ATG}	—	$5 t_{CYCP}^*$	—	ns	

* : t_{CYCP} is a cycle time of peripheral system clock.

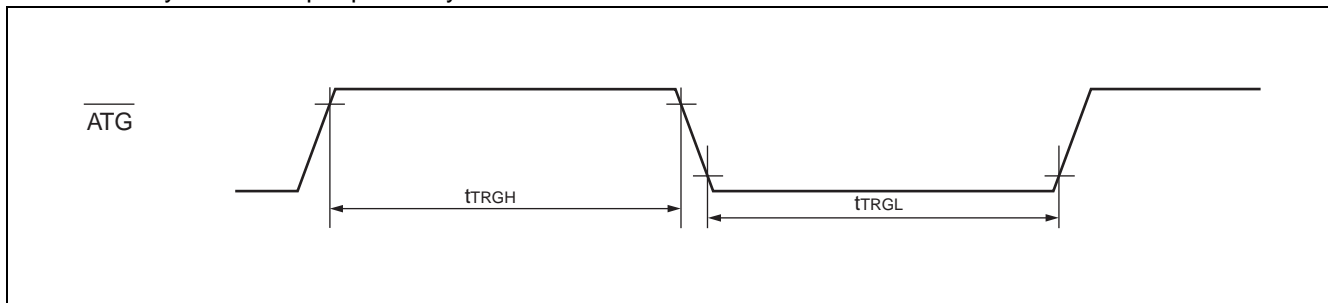

(11) Extrenal Interrupt Input Timing

($V_{CC} = 3.3\text{ V} \pm 0.3\text{ V}$, $V_{SS} = 0\text{ V}$, $T_A = -30\text{ }^\circ\text{C}$ to $+70\text{ }^\circ\text{C}$)

Parameter	Symbol	Pin name	Condition	Value		Unit	Remarks
				Min	Max		
Input pulse width	t_{INTWH}	INT0 to INT5	—	$5 t_{CYCP}$	—	ns	*1
	t_{INTWL}			1.0	—	μs	*2

*1: t_{CYCP} is a cycle time of peripheral system clock. Excluding the stop mode

*2: In Stop mode

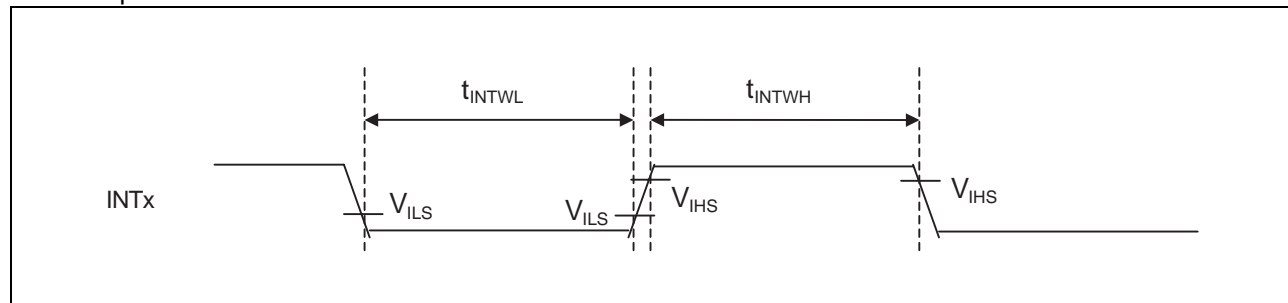

5. A/D Converter Block Electrical Characteristics

($V_{CC} = 3.3 \text{ V} \pm 0.3 \text{ V}$, $AV_{SS} = V_{SS} = 0 \text{ V}$, $T_A = -30 \text{ }^\circ\text{C}$ to $+70 \text{ }^\circ\text{C}$)

Parameter	Symbol	Pin name	Value			Unit	Remarks
			Min	Typ	Max		
Resolution	—	—	—	10	10	BIT	
Total error	—	—	—	—	± 4.0	LSB	
Linearity error	—	—	—	—	± 3.5	LSB	
Differential linearity error	—	—	—	—	± 2.0	LSB	
Zero transition voltage	V_{OT}	AN0 to AN7	$AV_{SS} - 1.5 \text{ LSB}$	$AV_{SS} + 0.5 \text{ LSB}$	$AV_{SS} + 2.5 \text{ LSB}$	V	
Full-scale transition voltage	V_{FST}	AN0 to AN7	$AVRH - 5.5 \text{ LSB}$	$AVRH - 1.5 \text{ LSB}$	$AVRH + 0.5 \text{ LSB}$	V	
Conversion time	—	—	5.3	—	—	μs	
Analog input current	I_{AIN}	AN0 to AN7	—	0.1	10	μA	
Analog input voltage	V_{AIN}	AN0 to AN7	AV_{SS}	—	$AVRH$	V	
Reference voltage	—	$AVRH$	AV_{SS}	—	AV_{CC}	V	
Power supply current	I_A	$AVCC$	—	3.0	5.0	mA	
	I_{AH}		—	—	5.0	μA	
Reference voltage supply current	I_R	$AVRH$	—	100	150	μA	
	I_{RH}		—	—	10	μA	
Variation among channels	—	AN0 to AN7	—	—	4	LSB	

Notes : • Relatively, the errors increase as $|AVRH - AV_{SS}|$ value becomes smaller.

- Define an output impedance of external circuit analog input under the following conditions :

Output impedance of external circuit $\leq 2 \text{ (k}\Omega\text{)}$

If an output impedance of external circuit is exceedingly high, sampling time for analog voltage may run short.

MB91129 Series

Analog input circuit model diagram

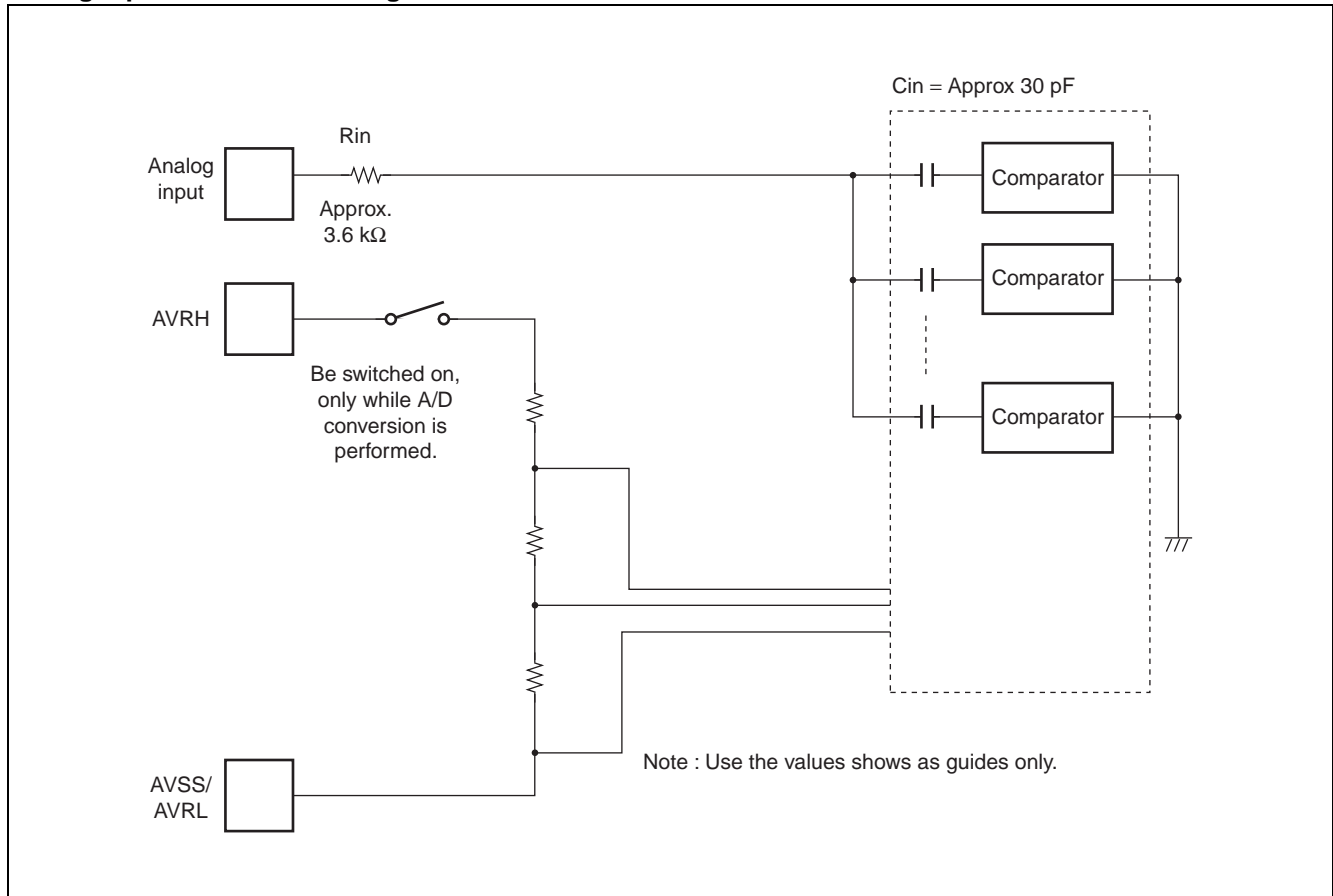

6. A/D Converter Block Electrical Characteristics

- Resolution
Analog variations recognized by an A/D converter.
- Linearity error
Deviation of actual conversion characteristics from an ideal line, which is across zero-transition point (“00 0000 0000” \leftrightarrow “00 0000 0001”) and full-scale transition point (“11 1111 1110” \leftrightarrow “11 1111 1111”)
- Differential linearity error
Deviation from ideal value of input voltage, which is required for changing output code by 1 LSB.
- Total error
Difference between actual value and ideal value. The error includes zero-transition error, full-scale transition error, and linearity error.

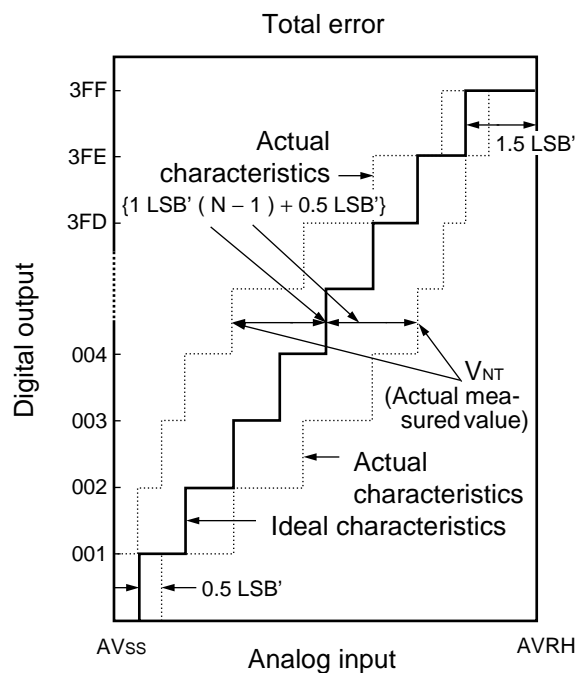

$$1 \text{ LSB}' (\text{Ideal value}) = \frac{AVRH - AVSS}{1024} \text{ [V]}$$

$$\text{Total error of digital output } N = \frac{V_{NT} - \{1 \text{ LSB}' \times (N - 1) + 0.5 \text{ LSB}'\}}{1 \text{ LSB}'}$$

V_{NT} : Transition voltage for digital output to change from (N+1) to N.

$$V_{OT}' (\text{Ideal value}) = AVSS + 0.5 \text{ LSB}' \text{ [V]}$$

$$V_{FST}' (\text{Ideal value}) = AVRH - 1.5 \text{ LSB}' \text{ [V]}$$

(Continued)

(Continued)

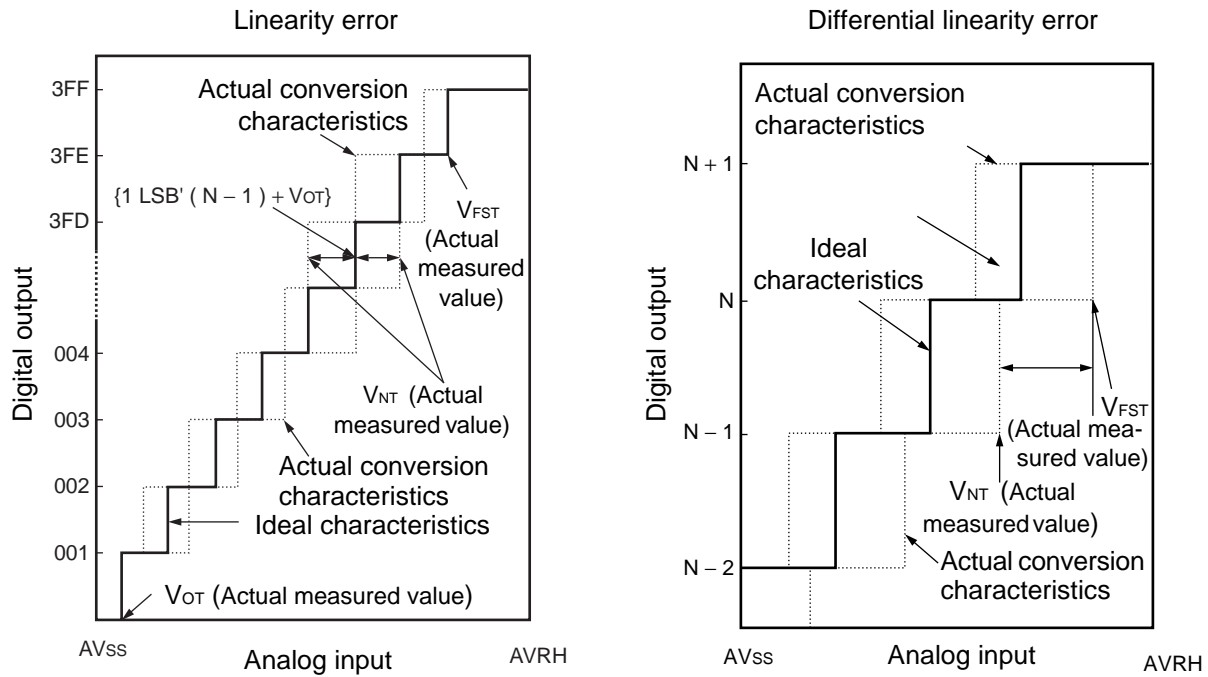

$$\text{Linearity error of digital output } N = \frac{V_{NT} - \{1 \text{ LSB}' \times (N - 1) + V_{OT}\}}{1 \text{ LSB}'} \quad [\text{LSB}]$$

$$\text{Differential linearity error of digital output } N = \frac{V_{(N+1)T} - V_{NT}}{1 \text{ LSB}'} - 1 \quad [\text{LSB}]$$

$$1 \text{ LSB} = \frac{V_{FST} - V_{OT}}{1022} \quad [\text{V}]$$

V_{OT} : Transition voltage for digital output to change from 000_H to 001_H.

V_{FST} : Transition voltage for digital output to change from 3FE_H to 3FF_H.

■ FLASH MEMORY WRITE/ERASE CHARACTERISTICS

Parameter	Condition	Value			Unit	Remarks
		Min	Typ	Max		
Sector erase time	$T_A = +25\text{ }^\circ\text{C}$, $V_{CC} = 3.3\text{ V}$	—	1	15	s	Not including time for internal writing before deletion.
Chip erase time		—	4	—	s	Not including time for internal writing before deletion.
Half byte (16 bit width) writing time		—	16	3600	μs	Not including system-level overhead time.
Write/erase cycle	—	—	10,000	—	cycle	
Data holding time	—	—	100,000	—	h	

MB91129 Series

EXAMPLE CHARACTERISTICS

- Power Supply Current

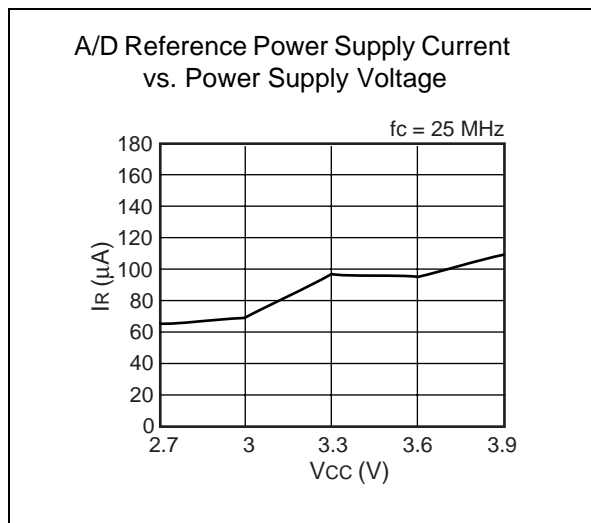
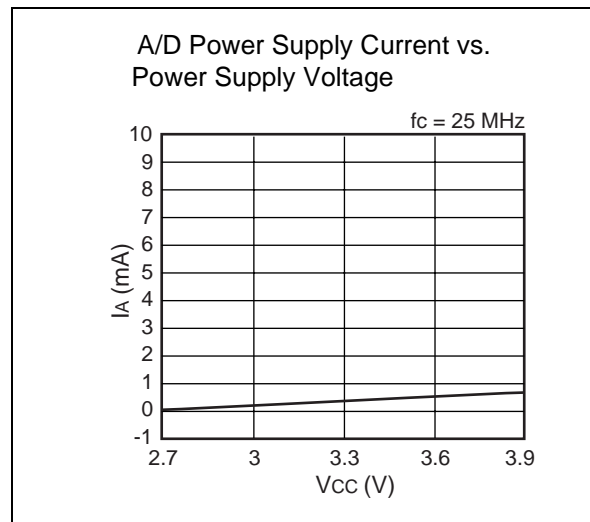
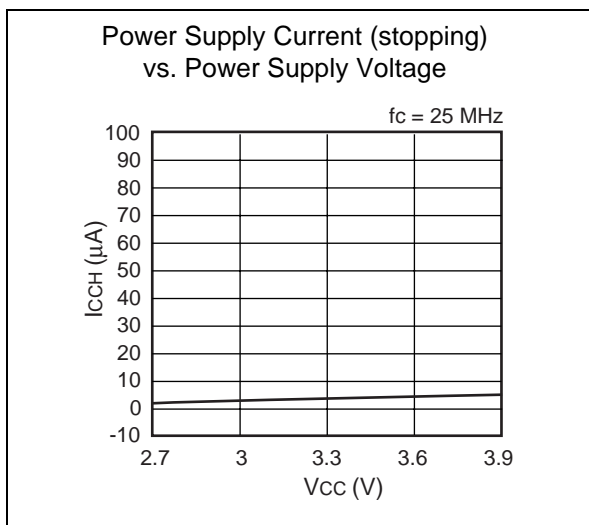
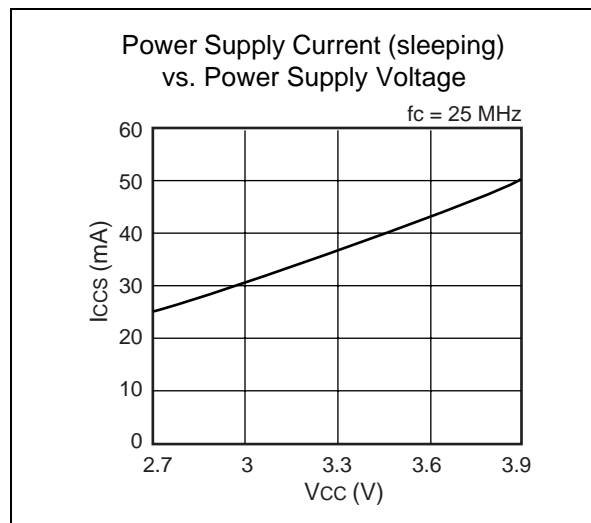
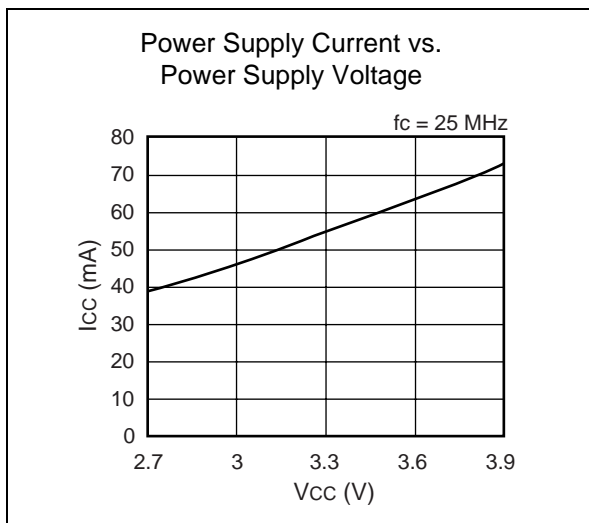

- Output Voltage

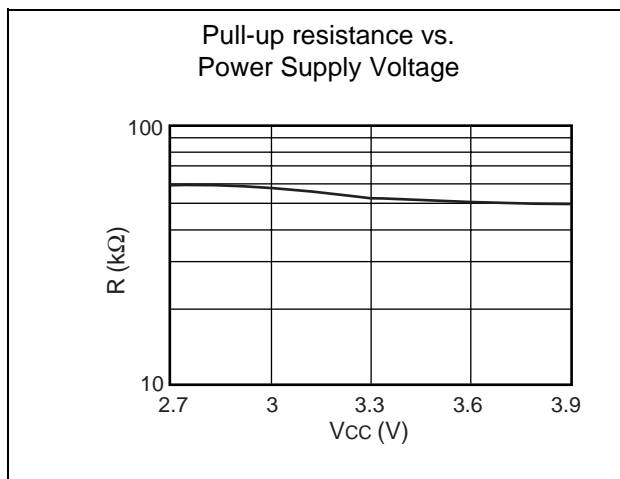
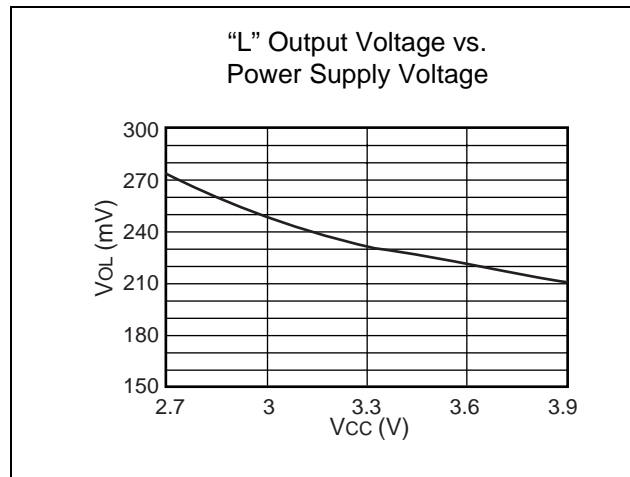
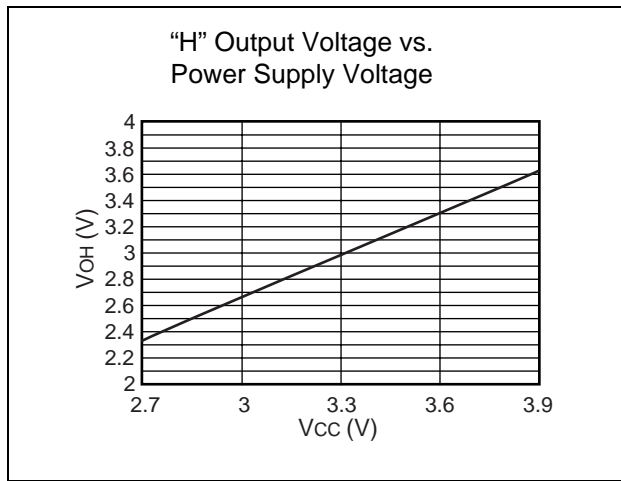

MB91129 Series

■ ORDERING INFORMATION

Part number	Package	Remarks
MB91F127PMC	100-pin plastic LQFP (FPT-100P-M20)	
MB91F128PMC	100-pin plastic LQFP (FPT-100P-M20)	

PACKAGE DIMENSIONS

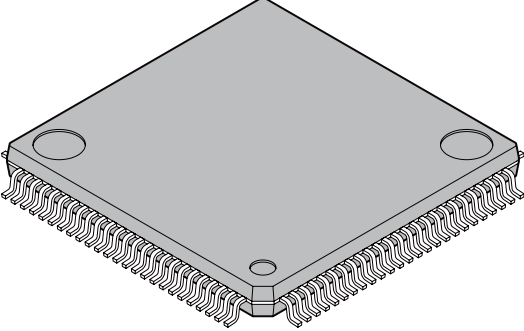
 <p>100-pin plastic LQFP</p> <p>(FPT-100P-M20)</p>	Lead pitch	0.50 mm
	Package width × package length	14.0 mm × 14.0 mm
	Lead shape	Gullwing
	Sealing method	Plastic mold
	Mounting height	1.70 mm Max
	Weight	0.65 g
	Code (Reference)	P-LFQFP100-14×14-0.50

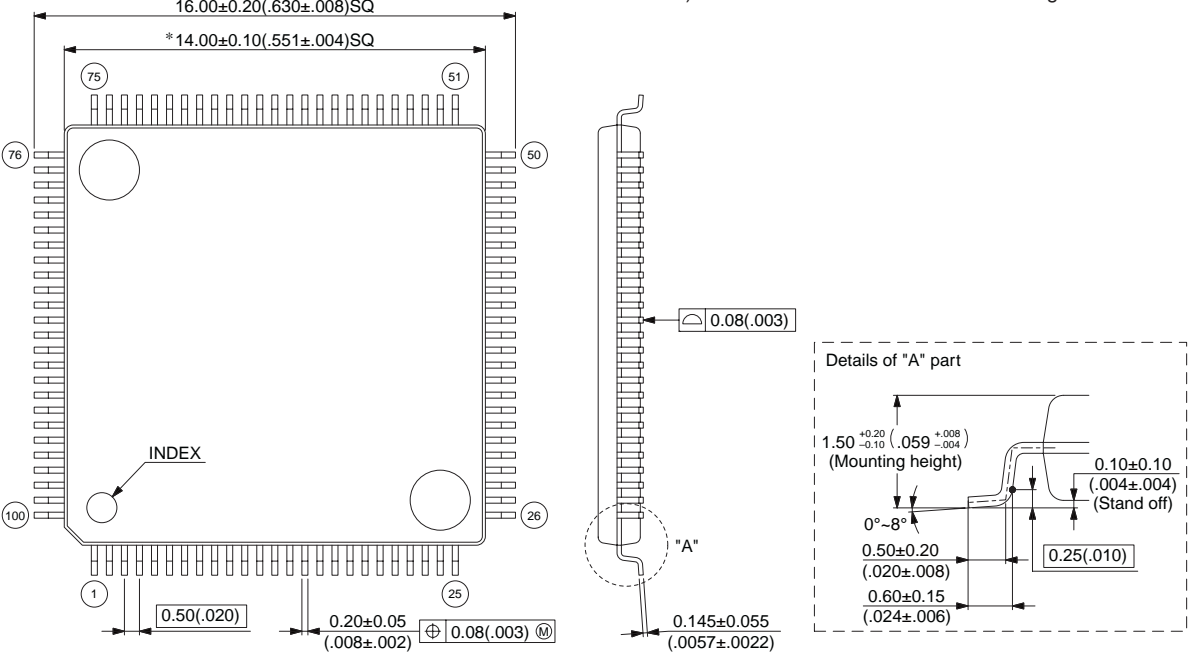
<p>100-pin plastic LQFP (FPT-100P-M20)</p>  <p>16.00±0.20(.630±.008)SQ *14.00±0.10(.551±.004)SQ</p> <p>INDEX</p> <p>0.50(.020) 0.20±0.05 (.008±.002) 0.08(.003) M</p> <p>0.145±0.055 (.0057±.0022)</p> <p>0.08(.003)</p> <p>Details of "A" part</p> <p>1.50^{+0.20}/_{-0.10} (.059^{+0.008}/_{-.004}) (Mounting height)</p> <p>0.10±0.10 (.004±.004) (Stand off)</p> <p>0°-8°</p> <p>0.50±0.20 (.020±.008)</p> <p>0.60±0.15 (.024±.006)</p> <p>0.25(.010)</p>	<p>Note 1) * : These dimensions do not include resin protrusion.</p> <p>Note 2) Pins width and pins thickness include plating thickness.</p> <p>Note 3) Pins width do not include tie bar cutting remainder.</p>
---	--

© 2005-2008 FUJITSU MICROELECTRONICS LIMITED F100031S-c-3-3

Dimensions in mm (inches).
Note: The values in parentheses are reference values

Please confirm the latest Package dimension by following URL.
<http://edevice.fujitsu.com/package/en-search/>

MB91129 Series

■ MAIN CHANGES IN THIS EDITION

Page	Section	Change Results
—	—	Changed the series name; (MB91F127/F128 → MB91129 series)
4, 48, 49	—	Changed the PACKAGE; (FPT-100P-M05 → FPT-100P-M20)
25	■ ELECTRICAL CHARACTERISTICS 1. Absolute Maximum Ratings	Added new note (the note number: *5). (Old note *5 → note *6)
35	■ ELECTRICAL CHARACTERISTICS 4. AC Characteristics (6) Timeshared Bus Access Read/Write Operations	Changed the "Parameter" column. WR0, 1 → WR0, WR1
37	■ ELECTRICAL CHARACTERISTICS 4. AC Characteristics (7) Ready Input Timing	Changed the "Parameter : setup time". RCLK↓ → CLK↓
38	■ ELECTRICAL CHARACTERISTICS 4. AC Characteristics (8) Hold Timing	Changed the "Parameter" column. Terminal → Signal
41	■ ELECTRICAL CHARACTERISTICS 5.1 A/D Converter Block Electrical Characteristics	Changed the symbol of "Zero transition voltage". (V _{0t} → V _{0T})
		Changed the items of "Zero transition voltage" and "Full scale transition voltage". (Unit : mV → V)
48	■ ORDERING INFORMATION	Changed the ORDERING INFORMATION name; (MB91F127PFV → MB91F127PMC MB91F128PFV → MB91F128PMC)

The vertical lines marked in the left side of the page show the changes.

MEMO

MB91129 Series

FUJITSU MICROELECTRONICS LIMITED

Shinjuku Dai-Ichi Seimei Bldg., 7-1, Nishishinjuku 2-chome,
Shinjuku-ku, Tokyo 163-0722, Japan
Tel: +81-3-5322-3347 Fax: +81-3-5322-3387
<http://jp.fujitsu.com/fml/en/>

For further information please contact:

North and South America

FUJITSU MICROELECTRONICS AMERICA, INC.
1250 E. Arques Avenue, M/S 333
Sunnyvale, CA 94085-5401, U.S.A.
Tel: +1-408-737-5600 Fax: +1-408-737-5999
<http://www.fma.fujitsu.com/>

Asia Pacific

FUJITSU MICROELECTRONICS ASIA PTE. LTD.
151 Lorong Chuan,
#05-08 New Tech Park 556741 Singapore
Tel : +65-6281-0770 Fax : +65-6281-0220
<http://www.fmal.fujitsu.com/>

Europe

FUJITSU MICROELECTRONICS EUROPE GmbH
Pittlerstrasse 47, 63225 Langen, Germany
Tel: +49-6103-690-0 Fax: +49-6103-690-122
<http://emea.fujitsu.com/microelectronics/>

FUJITSU MICROELECTRONICS SHANGHAI CO., LTD.

Rm. 3102, Bund Center, No.222 Yan An Road (E),
Shanghai 200002, China
Tel : +86-21-6146-3688 Fax : +86-21-6335-1605
<http://cn.fujitsu.com/fmc/>

Korea

FUJITSU MICROELECTRONICS KOREA LTD.
206 Kosmo Tower Building, 1002 Daechi-Dong,
Gangnam-Gu, Seoul 135-280, Republic of Korea
Tel: +82-2-3484-7100 Fax: +82-2-3484-7111
<http://kr.fujitsu.com/fmk/>

FUJITSU MICROELECTRONICS PACIFIC ASIA LTD.

10/F., World Commerce Centre, 11 Canton Road,
Tsimshatsui, Kowloon, Hong Kong
Tel : +852-2377-0226 Fax : +852-2376-3269
<http://cn.fujitsu.com/fmc/en/>

Specifications are subject to change without notice. For further information please contact each office.

All Rights Reserved.

The contents of this document are subject to change without notice.

Customers are advised to consult with sales representatives before ordering.

The information, such as descriptions of function and application circuit examples, in this document are presented solely for the purpose of reference to show examples of operations and uses of FUJITSU MICROELECTRONICS device; FUJITSU MICROELECTRONICS does not warrant proper operation of the device with respect to use based on such information. When you develop equipment incorporating the device based on such information, you must assume any responsibility arising out of such use of the information.

FUJITSU MICROELECTRONICS assumes no liability for any damages whatsoever arising out of the use of the information.

Any information in this document, including descriptions of function and schematic diagrams, shall not be construed as license of the use or exercise of any intellectual property right, such as patent right or copyright, or any other right of FUJITSU MICROELECTRONICS or any third party or does FUJITSU MICROELECTRONICS warrant non-infringement of any third-party's intellectual property right or other right by using such information. FUJITSU MICROELECTRONICS assumes no liability for any infringement of the intellectual property rights or other rights of third parties which would result from the use of information contained herein.

The products described in this document are designed, developed and manufactured as contemplated for general use, including without limitation, ordinary industrial use, general office use, personal use, and household use, but are not designed, developed and manufactured as contemplated (1) for use accompanying fatal risks or dangers that, unless extremely high safety is secured, could have a serious effect to the public, and could lead directly to death, personal injury, severe physical damage or other loss (i.e., nuclear reaction control in nuclear facility, aircraft flight control, air traffic control, mass transport control, medical life support system, missile launch control in weapon system), or (2) for use requiring extremely high reliability (i.e., submersible repeater and artificial satellite).

Please note that FUJITSU MICROELECTRONICS will not be liable against you and/or any third party for any claims or damages arising in connection with above-mentioned uses of the products.

Any semiconductor devices have an inherent chance of failure. You must protect against injury, damage or loss from such failures by incorporating safety design measures into your facility and equipment such as redundancy, fire protection, and prevention of over-current levels and other abnormal operating conditions.

Exportation/release of any products described in this document may require necessary procedures in accordance with the regulations of the Foreign Exchange and Foreign Trade Control Law of Japan and/or US export control laws.

The company names and brand names herein are the trademarks or registered trademarks of their respective owners.