

16-bit Microcontroller

CMOS

F²MC-16LX MB90910 Series

MB90911AS/F912BS/V950AMAS

■ DESCRIPTION

The MB90910 series, loaded 1 channel FULL-CAN controller and Flash ROM, is general-purpose FUJITSU 16-bit microcontroller designing for automotive and industrial applications. Its main feature is the on-board CAN controllers, which conform to Ver 2.0 Part A and Part B, while supporting a very flexible message buffer scheme and so offering more functions than a normal FULL-CAN approach. With the new 0.18 μm CMOS technology, Fujitsu now offers on-chip Flash ROM program memory up to 128 Kbytes.

The power supply (1.8 V) is supplied to the MCU core from an internal regulator circuit. This creates a major advantage in terms of EMI and power consumption.

The internal PLL clock frequency multiplier provides an internal 31.25 ns instruction execution time from an external 4 MHz clock.

The unit features a 4-channel input capture unit 1 channel 16-bit free-run timer, 2-channel LIN-UART, 1-channel UART, and 16-channel 8/10-bit A/D converter as the peripheral resource.

Note : F²MC is the abbreviation of FUJITSU Flexible Microcontroller.

For the information for microcontroller supports, see the following web site.

<http://edevic.fujitsu.com/micom/en-support/>

■ FEATURES

• Clock

- Built-in PLL clock frequency multiplication circuit
- Selection of machine clocks (PLL clocks) is allowed among frequency division by 2 on oscillation clock and multiplication of 1 to 8 times of oscillation clock (for 4 MHz oscillation clock, 4 MHz to 32 MHz)
- Minimum execution time of instruction : 31.25 ns (when operating with 4-MHz oscillation clock and 8-time multiplied PLL clock)

• Instruction system best suited to controller

- 16 Mbytes CPU memory space
- 24-bit internal addressing
- Wide choice of data types (bit, byte, word, and long word)
- Wide choice of addressing modes (23 types)
- Enhanced multiply-divide instructions with sign and RETI instructions
- Enhanced high-precision computing with 32-bit accumulator

• Instruction system compatible with high-level language (C language) and multitask

- Employing system stack pointer
- Enhanced various pointer indirect instructions
- Barrel shift instructions

• Increased processing speed

4-byte instruction queue

• Powerful interrupt function

- Powerful 8-level, 34-condition interrupt feature
- Up to 8 channels external interrupts are supported

• CPU-independent automatic data transfer function

Expanded intelligent I/O service function (EI²OS) : up to 16 channels

• Low power consumption (standby) mode

- Sleep mode (a mode that halts CPU operating clock)
- Main timer mode (timebase timer mode that is transferred from main clock mode)
- PLL timer mode (timebase timer mode that is transferred from PLL clock mode)
- Stop mode (a mode that stops oscillation clock)
- CPU blocking operation mode

• Process

CMOS technology

• I/O port

General purpose input/output port (CMOS output) :

- 36 ports

• Timer

- Timebase timer, watchdog timer : 1 channel
- 8/16-bit PPG timer : 8-bit × 6 channels or 16-bit × 3 channels
- 16-bit reload timer : 2 channels
- 16-bit input/output timer
 - 16-bit free-run timer : 1 channel (FRT0 : ICU 0/1/2/3)
 - 16-bit input capture : (ICU) : 4 channels

• FULL-CAN controller : 1 channel

- Compliant with CAN specifications Version 2.0 Part A and B
- 16 message buffers are built in
- CAN wake-up function

(Continued)

(Continued)

- **UART (LIN/SCI) : LIN-UART × 2 channels, UART × 1 channel**
 - Equipped with full-duplex double buffer
 - Clock-asynchronous or clock-synchronous serial transmission is available
- **DTP/External interrupt : up to 8 channels, CAN wakeup : up to 1 channel**

Module for activation of expanded intelligent I/O service (EI²OS) and generation of external interrupt by external input
- **Delay interrupt generator module**

Generates interrupt request for task switching
- **8/10-bit A/D converter : 16 channels**
 - Resolution is selectable between 8-bit and 10-bit
 - Activation by external trigger input is allowed
 - Conversion time : 3 μs (at 24 MHz machine clock, including sampling time)
- **Program patch function**

Address matching detection for 6 address pointers
- **Capable of changing input voltage for port**

Automotive/CMOS-Schmitt input level (initial level is Automotive in single-chip mode)
- **ROM security function**

The content of ROM can be protected (Only MASK ROM product).
- **Flash memory security function**

Protects the content of Flash memory

MB90910 Series

■ PRODUCT LINEUP

Part number Parameter	MB90V950AMAS	MB90F912BS	MB90911AS
Type	Evaluation product	Flash memory product	MASK ROM product
CPU	F ² MC-16LX CPU		
System clock	On-chip PLL clock multiplier (×1, ×2, ×3, ×4, ×6, ×8, 1/2 when PLL stops) Minimum instruction execution time : 31.25 ns (4 MHz osc. PLL ×8)		
ROM	External	128 Kbytes	64 Kbytes
RAM	30 Kbytes	8 Kbytes	4 Kbytes
Emulator-specific power supply*1	Yes	—	
FPGA data*2	Rev 050617	—	
Adaptor board*2	MB2147-20 Rev.04C or later	—	
Technology	0.35 μm CMOS with built-in power supply regulator	0.18 μm CMOS with built-in power supply regulator	
Operation voltage range	5 V ± 10 %	3.0 V to 5.5 V : When normal operating	
Operating ambient temperature	—	−40 °C to +105 °C	
Package	PGA-299	LQFP-48	
UART	LIN-UART × 7 channels	LIN-UART × 2 channels, UART × 1 channel	
	Wide range of baud rate settings using a dedicated reload timer Special synchronous options for adapting to different synchronous serial protocols LIN functionality working either as master or slave LIN device (Supported by LIN-UART only)		
I ² C (400 kbps)	2 channels	—	
A/D converter	24 input channels	16 input channels	
	10-bit or 8-bit resolution Conversion time : Min 3 μs include sample time (per one channel)		
16-bit Reload timer	4 channels	2 channels	
	Operation clock frequency : f _{sys} /2 ¹ , f _{sys} /2 ³ , f _{sys} /2 ⁵ (f _{sys} = Machine clock frequency) Supports External Event Count function		
16-bit I/O timer	2 channels	1 channel	
	Generates an interrupt signal on overflow Operation clock freq. : f _{sys} , f _{sys} /2 ¹ , f _{sys} /2 ² , f _{sys} /2 ³ , f _{sys} /2 ⁴ , f _{sys} /2 ⁵ , f _{sys} /2 ⁶ , f _{sys} /2 ⁷ (f _{sys} = Machine clock freq.) I/O Timer 0 (clock input FRCK0) corresponds to ICU0/1/2/3, OCU 0/1/2/3 I/O Timer 1 (clock input FRCK1) corresponds to ICU4/5/6/7, OCU 4/5/6/7		
16-bit Output compare	8 channels	—	
	Generates an interrupt signal when one of the 16-bit I/O timer matches the output compare register A pair of compare registers can be used to generate an output signal.		

(Continued)

MB90910 Series

(Continued)

Part number Parameter	MB90V950AMAS	MB90F912BS	MB90911AS
16-bit Input capture	8 channels	4 channels	
	Rising edge, falling edge or rising & falling edge sensitive Signals an interrupt upon external event		
8/16-bit PPG	8 channels (16-bit) /16 channels (8-bit) Sixteen 8-bit reload counters Sixteen 8-bit reload registers for L pulse width Sixteen 8-bit reload registers for H pulse width	3 channels (16-bit) /6 channels (8-bit) Six 8-bit reload counters Six 8-bit reload registers for L pulse width Six 8-bit reload registers for H pulse width	
	Supports 8-bit and 16-bit operation modes A pair of 8-bit reload counters can be configured as one 16-bit reload counter or as 8-bit prescaler plus 8-bit reload counter Operating clock freq. : fsys, fsys/2 ¹ , fsys/2 ² , fsys/2 ³ , fsys/2 ⁴ or 128 μs@fosc = 4 MHz (fsys = Machine clock frequency, fosc = Oscillation clock frequency)		
CAN controller	3 channels	1 channel	
	Conforms to CAN Specification Version 2.0 Part A and B Automatic re-transmission in case of error Automatic transmission in response to Remote Frames Prioritized 16 message buffers for data and ID's Supports multiple messages Flexible configuration of acceptance filtering : Full bit compare/Full bit mask/Two partial bit masks Supports up to 1 Mbps		
DTP/External interrupt (8 channels)	Can be used rising edge, falling edge, starting up by H/L level input, external interrupt, expanded intelligent I/O services (EI ² OS)		
D/A Converter	8-bit × 2 channels	—	
I/O Ports	Virtually all external pins can be used as general purpose I/O port All ports are push-pull outputs Bit-wise settable as input/output or peripheral signal Can be configured 8 as CMOS schmitt trigger/ automotive inputs (in blocks of 8 pins) TTL input level settable for external bus (32-pin only for external bus)		
Flash memory (Flash memory product only)	Supports automatic programming, Embedded Algorithm Write/Erase/Erase-Suspend/Resume commands A flag indicating completion of the algorithm Boot block configuration Erase can be performed on each block Flash Security		

*1: It is setting of Jumper switch (TOOL VCC) when emulator (MB2147-01) is used. Please refer to the Emulator hardware manual for the details.

*2: Contact the sales or support representative if using other than those above of FPGA data and adaptor boards.

MB90910 Series

■ PIN ASSIGNMENT

- MB90F912BS, MB90911AS

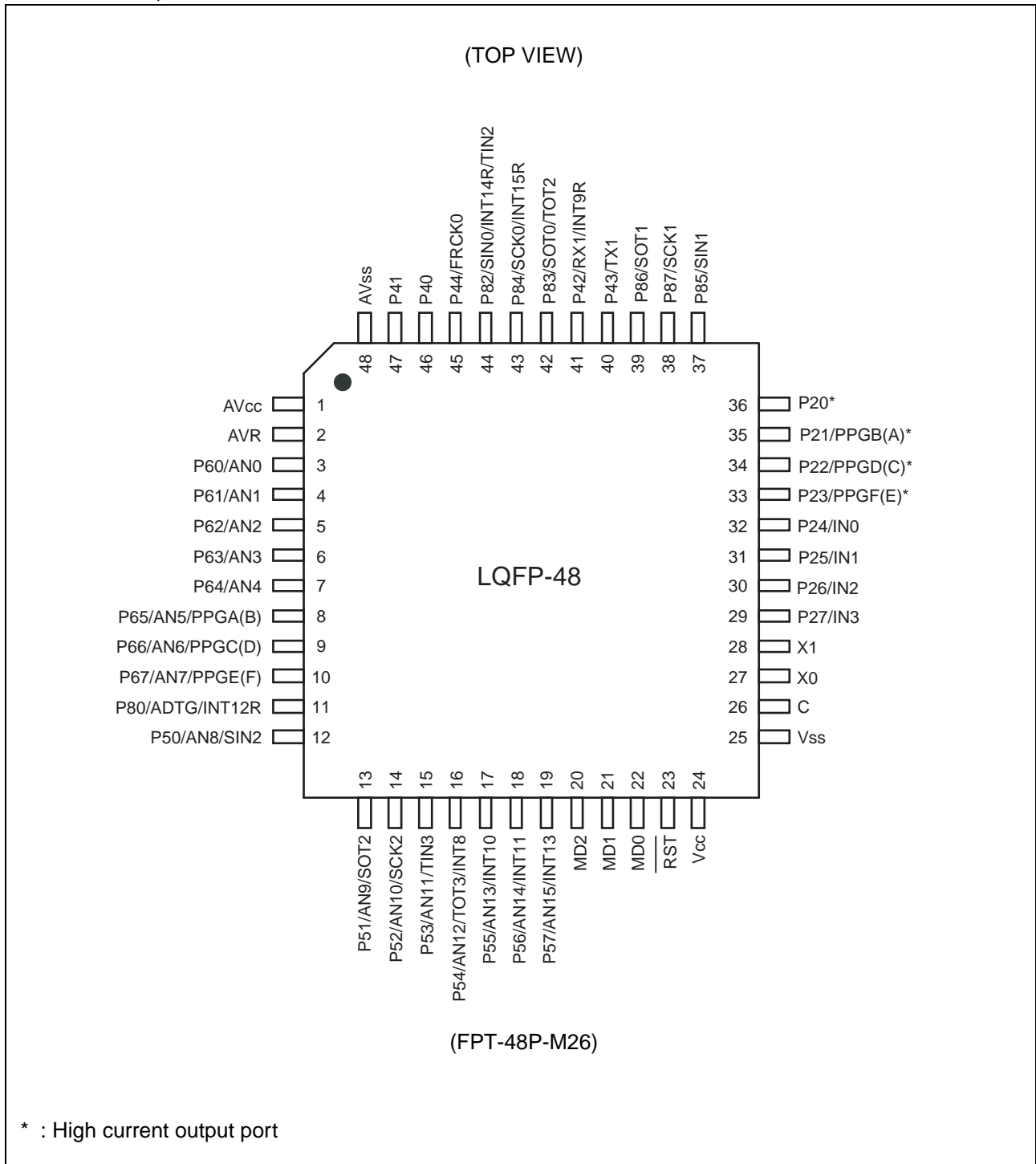

■ PIN DESCRIPTION

Pin No.	Pin name	I/O circuit type*	Function
1	AV _{CC}	I	V _{CC} power input pin for analog circuit.
2	AVR	—	Power (V _{ref+}) input pin for A/D converter. It should be below V _{CC} .
3 to 7	P60 to P64	H	General-purpose I/O port.
	AN0 to AN4		Analog input pins for A/D converter.
8 to 10	P65 to P67	H	General-purpose I/O port.
	AN5 to AN7		Analog input pins for A/D converter.
	PPGA (B) , PPGC (D) , PPGE (F)		Output pins for PPG.
11	P80	F	General-purpose I/O port.
	ADTG		Trigger input pin for A/D converter.
	INT12R		External interrupt request input pin for INT12R.
12	P50	L	General-purpose I/O port.
	AN8		Analog input pin for A/D converter.
	SIN2		Serial data input pin for UART2.
13	P51	H	General-purpose I/O port.
	AN9		Analog input pin for A/D converter.
	SOT2		Serial data output pin for UART2.
14	P52	H	General-purpose I/O port.
	AN10		Analog input pin for A/D converter.
	SCK2		Clock I/O pin for UART2.
15	P53	H	General-purpose I/O port.
	AN11		Analog input pin for A/D converter.
	TIN3		Event input pin for reload timer 3.
16	P54	H	General-purpose I/O port.
	AN12		Analog input pin for A/D converter.
	TOT3		Output pin for reload timer 3
	INT8		External interrupt request input pin for INT8.
17	P55	H	General-purpose I/O port.
	AN13		Analog input pin for A/D converter.
	INT10		External interrupt request input pin for INT10.

(Continued)

MB90910 Series

Pin No.	Pin name	I/O circuit type*	Function
18	P56	H	General-purpose I/O port (Different I/O circuit type from MB90V950AMAS).
	AN14		Analog input pin for A/D converter.
	INT11		External interrupt request input pin for INT11.
19	P57	H	General-purpose I/O port (Different I/O circuit type from MB90V950AMAS).
	AN15		Analog input pin for A/D converter.
	INT13		External interrupt request input pin for INT13.
20	MD2	D	Input pin for operation mode specification.
21, 22	MD1, MD0	C	Input pins for operation mode specification.
23	\overline{RST}	E	Reset input pin.
24	V _{CC}	—	Power input pin (3.5 V to 5.5 V) .
25	V _{SS}	—	Power input pin (0 V) .
26	C	I	Power supply stabilization capacitor pin. It should be connected to a higher than or equal to 0.1 μ F ceramic condenser.
27	X0	A	Oscillation input pin.
28	X1		Oscillation output pin.
29 to 32	P27 to P24	G	General-purpose I/O port. The register can be set to select whether to use a pull-up resistor. This function is enabled in single-chip mode.
	IN3 to IN0		Event input pins for input capture 0 to 3.
33 to 35	P23 to P21	J	General-purpose I/O port. The register can be set to select whether to use a pull-up resistor. This function is enabled in single-chip mode. High current output port (Different I/O circuit type from MB90V950AMAS).
	PPGF (E) , PPGD (C) , PPGB(A)		Output pins for PPG.
36	P20	J	General-purpose I/O port. The register can be set to select whether to use a pull-up resistor. This function is enabled in single-chip mode. High current output port (Different I/O circuit type from MB90V950AMAS).
37	P85	K	General-purpose I/O port.
	SIN1		Serial data input pin for UART1.
38	P87	F	General-purpose I/O port.
	SCK1		Clock I/O pin for UART1.
39	P86	F	General-purpose I/O port.
	SOT1		Serial data output pin for UART1.

(Continued)

(Continued)

Pin No.	Pin name	I/O circuit type*	Function
40	P43	F	General-purpose I/O port.
	TX1		TX output pin for CAN1 controller.
41	P42	F	General-purpose I/O port.
	RX1		RX input pin for CAN1 controller.
	INT9R		External interrupt request input pin for INT9R.
42	P83	F	General-purpose I/O port.
	SOT0		Serial data output pin for UART0.
	TOT2		Output pin for reload timer 2.
43	P84	F	General-purpose I/O port.
	SCK0		Clock I/O pin for UART0.
	INT15R		External interrupt request input pin for INT15R.
44	P82	K	General-purpose I/O port.
	SIN0		Serial data input pin for UART0.
	INT14R		External interrupt request input pin for INT14R.
	TIN2		Event input pin for reload timer 2.
45	P44	F	General-purpose I/O port (Different I/O circuit type from MB90V950AMAS).
	FRCK0		Free-run timer 0 clock input pin.
46, 47	P40, P41	F	General-purpose I/O port
48	AV _{ss}	I	V _{ss} power input pin for analog circuit.

* : For the I/O circuit type, refer to “■ I/O CIRCUIT TYPE”.

MB90910 Series

■ I/O CIRCUIT TYPE

Type	Circuit	Remarks
A		Oscillation circuit : High-speed oscillation feedback resistor = approx. 1 MΩ (MASK ROM product, Flash memory product)
		Oscillation circuit : High-speed oscillation feedback resistor = approx. 1 MΩ (Evaluation product)
B		Unused
C		<ul style="list-style-type: none"> • MASK ROM product / Evaluation product : CMOS hysteresis input pin • Flash memory product : CMOS input pin
D		<ul style="list-style-type: none"> • MASK ROM product / Evaluation product : CMOS hysteresis input pin • Flash memory product : <ul style="list-style-type: none"> - CMOS input pin - No Pull-down
E		CMOS hysteresis input pin

(Continued)

Type	Circuit	Remarks
F		<ul style="list-style-type: none"> • CMOS level output ($I_{OL} = 4 \text{ mA}$, $I_{OH} = -4 \text{ mA}$) • CMOS hysteresis inputs ($V_{IH}0.8V_{CC}$ $V_{IL}0.2V_{CC}$) (With the standby-time input shutdown function) • Automotive input (With the standby-time input shutdown function)
G		<ul style="list-style-type: none"> • CMOS level output ($I_{OL} = 4 \text{ mA}$, $I_{OH} = -4 \text{ mA}$) • CMOS hysteresis inputs ($V_{IH}0.8V_{CC}$ $V_{IL}0.2V_{CC}$) (With the standby-time input shutdown function) • Automotive input (With the standby-time input shutdown function)
H		<ul style="list-style-type: none"> • CMOS level output ($I_{OL} = 4 \text{ mA}$, $I_{OH} = -4 \text{ mA}$) • CMOS hysteresis inputs ($V_{IH}0.8V_{CC}$ $V_{IL}0.2V_{CC}$) (With the standby-time input shutdown function) • Automotive input (With the standby-time input shutdown function) • A/D analog input

(Continued)

MB90910 Series

Type	Circuit	Remarks
I		Protection circuit for power supply input
J		<ul style="list-style-type: none"> • CMOS level output ($I_{OL} = 20 \text{ mA}$, $I_{OH} = -14 \text{ mA}$) (MB90V950: $I_{OL} = 4 \text{ mA}$, $I_{OH} = -4 \text{ mA}$) • CMOS hysteresis inputs ($V_{IH}0.8V_{CC}$ $V_{IL}0.2V_{CC}$) (With the standby-time input shutdown function) • Automotive input (With the standby-time input shutdown function)
K		<ul style="list-style-type: none"> • CMOS level output ($I_{OL} = 4 \text{ mA}$, $I_{OH} = -4 \text{ mA}$) • CMOS hysteresis input ($V_{IH}0.7V_{CC}$ $V_{IL}0.3V_{CC}$) (With standby-time input shutdown function) • Automotive input (With standby-time input shutdown function) • CMOS hysteresis inputs ($V_{IH}0.8V_{CC}$ $V_{IL}0.2V_{CC}$) (With the standby-time input shutdown function)

(Continued)

(Continued)

Type	Circuit	Remarks
L	<p>The diagram shows a common node connected to a P-channel MOSFET (Pout) and an N-channel MOSFET (Nout). This node is also connected to a resistor R and a square-wave input signal. From this node, four separate input lines are shown, each connected to a different input type: CMOS hysteresis input, Automotive input, CMOS hysteresis inputs, Standby control for input shutdown, and Analog input.</p>	<ul style="list-style-type: none"> • CMOS level output ($I_{OL} = 4 \text{ mA}$, $I_{OH} = -4 \text{ mA}$) • CMOS hysteresis inputs ($V_{IH}0.8V_{CC}$ $V_{IL}0.2V_{CC}$) (With the standby-time input shut-down function) • Automotive input (With the standby-time input shut-down function) • CMOS hysteresis input ($V_{IH}0.7V_{CC}$ $V_{IL}0.3V_{CC}$) (With the standby-time input shut-down function) • A/D analog input

■ HANDLING DEVICES

1. Preventing latch-up

CMOS IC chips may suffer latch-up under the following conditions :

- A voltage higher than V_{CC} pin or lower than V_{SS} pin is applied to an input or output pin.
- A voltage higher than the rated voltage is applied between V_{CC} pin and V_{SS} pin.
- The AV_{CC} power supply is applied before the V_{CC} voltage.

Latch-up may increase the power supply current drastically, causing thermal damage to the device.

Use meticulous care not to exceed the rating.

For the same reason, also be careful not to let the analog power-supply voltage (AV_{CC} , AVR) exceed the digital power-supply voltage.

2. Treatment of unused pins

Leaving unused input pins open may result in permanent damage of the device due to misbehavior or latch-up. Therefore, they must be pulled up or pulled down through resistors. In this case, those resistors should be more than 2 k Ω .

Unused bidirectional pins should be set to the output state and can be left open, or the input state with the above described connection.

3. Using external clock

The high-speed oscillator pins (X0, X1) can not be used for external clock inputs.

4. Notes on during operation of PLL clock mode

On this microcontroller, if in case the crystal oscillator breaks off or an external reference clock input stops while the PLL clock mode is selected, a self-oscillator circuit contained in the PLL may continue its operation at its self-running frequency. However, Fujitsu will not guarantee results of operations if such failure occurs.

5. Power supply pins (V_{CC}/V_{SS})

- If there are multiple V_{CC} and V_{SS} pins, from the point of view of device design, pins to be of the same potential are connected the inside of the device to prevent malfunction such as latch-up.
To reduce unnecessary radiation, prevent malfunctioning of the strobe signal due to the rise of ground level, and observe the standard for total output current, be sure to connect the V_{CC} and V_{SS} pins to the power supply and ground externally.
- Connect V_{CC} and V_{SS} pins to the device from the current supply source at a low impedance.
- As a measure against power supply noise, connect a capacitor of about 0.1 μF as a bypass capacitor between V_{CC} pin and V_{SS} pin in the vicinity of V_{CC} and V_{SS} pins of the device.

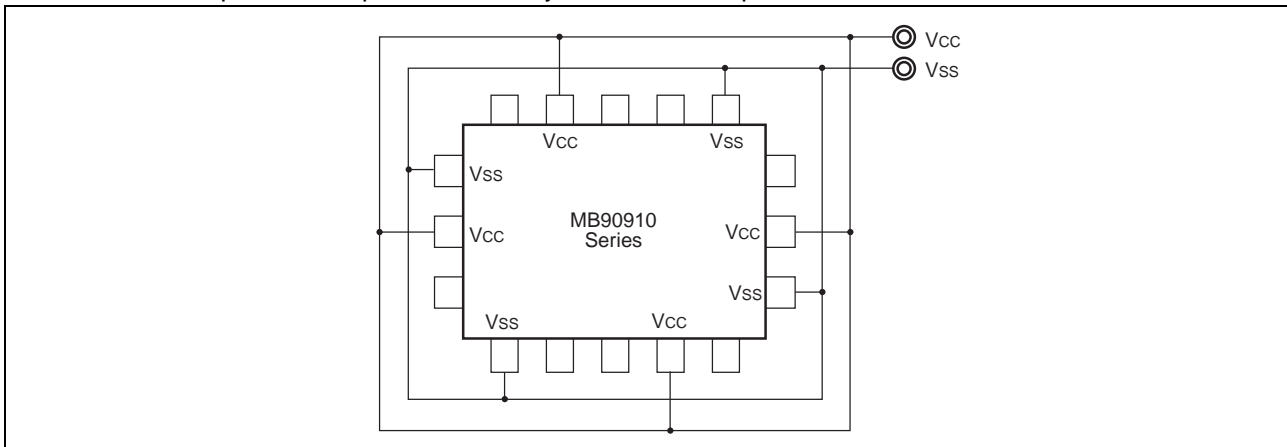

6. Pull-up/down resistors

The MB90910 series does not support internal pull-up/down resistors (Port 2 : built-in pull-up resistors) . Use external components where needed.

7. Crystal oscillator circuit

Noises around X0 or X1 pin may be possible causes of malfunctions. Make sure to provide bypass capacitors via shortest distance from X0, X1 pins, crystal oscillator (or ceramic resonator) and ground lines, and make sure, that lines of oscillation circuit do not cross the lines of other circuits.

It is highly recommended to provide a printed circuit board artwork surrounding X0 and X1 pins with a ground area for stabilizing the operation. Please ask the crystal maker to evaluate the oscillational characteristics of the crystal and this device.

8. Turning-on sequence of power supply to A/D converter and analog inputs

Make sure to turn on the A/D converter power supply (AV_{CC} and AVR) and analog inputs ($AN0$ to $AN15$) after turning-on the digital power supply (V_{CC}) .

Turn-off the digital power after turning off the A/D converter power supply and analog inputs. In this case, make sure that the voltage does not exceed $AVRH$ or AV_{CC} .

9. Connection of unused pins of A/D converter if A/D converter is not used

Connect unused pins of A/D converter to $AV_{CC} = V_{CC}$, $AV_{SS} = AVR = V_{SS}$.

10. Notes on energization

To prevent the internal regulator circuit from malfunctioning, set the voltage rise time during energization at 50 μs or more (0.2 V to 2.7 V) .

11. Stabilization of power supply voltage

A sudden change in the power supply voltage may cause the device to malfunction even within the specified V_{CC} power supply voltage operating guarantee range. Therefore, the V_{CC} power supply voltage should be stabilized.

For reference, the power supply voltage should be controlled so that V_{CC} ripple variations (peak-to-peak value) at commercial frequencies (50 Hz/60 Hz) fall below 10% of the standard V_{CC} power supply voltage and the coefficient of transient fluctuation does not exceed 0.1 V/ms at instantaneous power switching.

12. Initialization

In the device, there are internal registers which are initialized only by a power-on reset. To initialize these registers, turn on the power again.

13. Notes on using CAN function

To use CAN function, please set '1' to DIRECT bit of CAN direct mode register (CDMR) .

If DIRECT bit is set to '0' (initial value) , wait states will be performed when accessing CAN registers.

Note : Please refer to Hardware Manual of "MB90910 series for detail of CAN Direct Mode Register".

14. Flash security function

The security bit is located in the area of the Flash memory.

If protection code 01_H is written in the security bit, the Flash memory is in the protected state by security.

Therefore, please do not write 01_H in this address if you do not use the security function.

Please refer to following table for the address of the security bit.

	Flash memory size	Address for security bit
MB90F912BS	Embedded 1 Mbit Flash Memory	FE0001 _H

15. Correspondence with $T_A = +105\text{ }^\circ\text{C}$ or more

If used exceeding $T_A = +105\text{ }^\circ\text{C}$, please consult with us due to the restricted reliability.

It is ensured to write/erase data to the Flash memory between $T_A = -40\text{ }^\circ\text{C}$ and $+105\text{ }^\circ\text{C}$.

■ BLOCK DIAGRAMS

• MB90V950AMAS

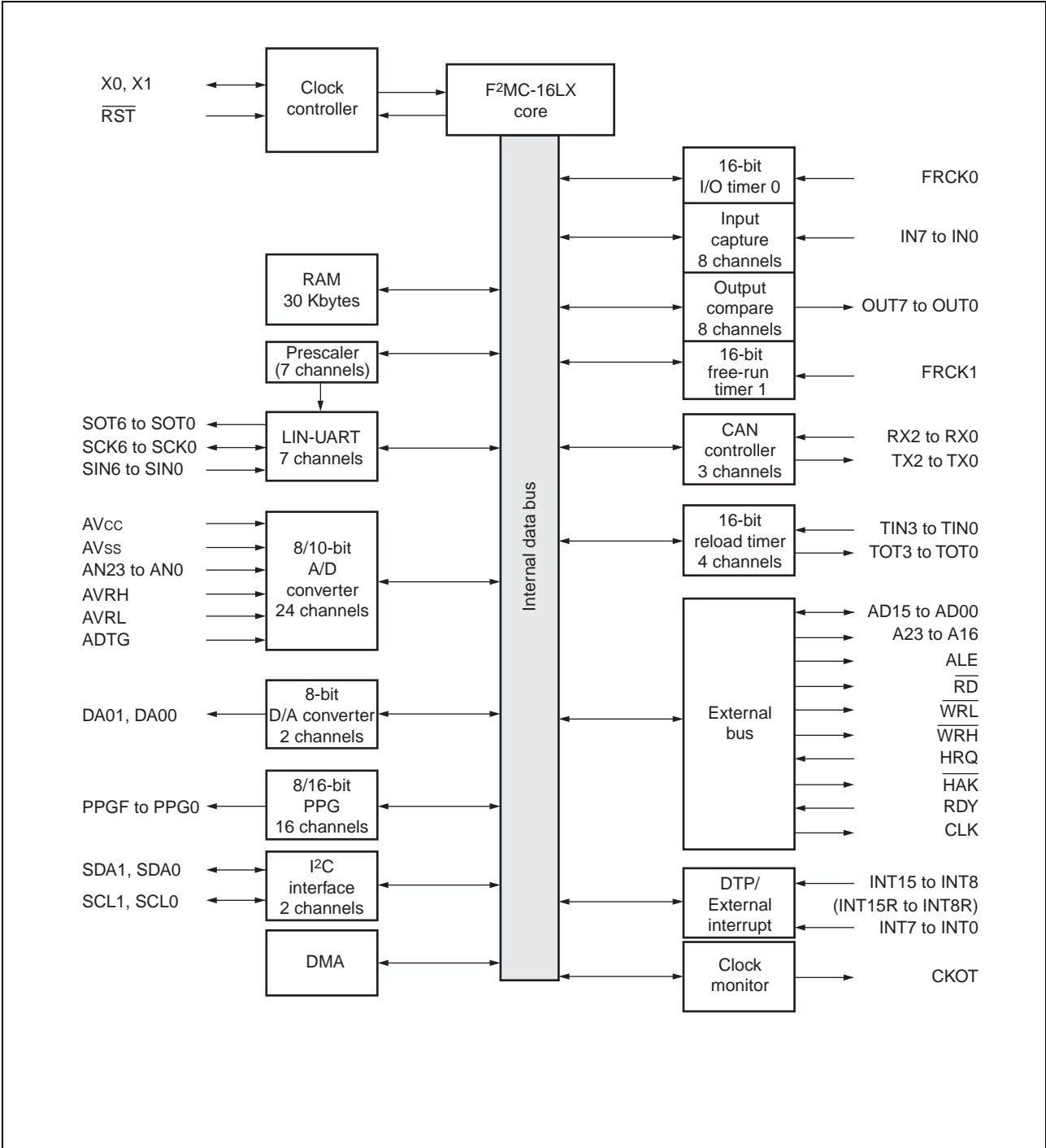

MB90910 Series

• MB90F912BS, MB90911AS

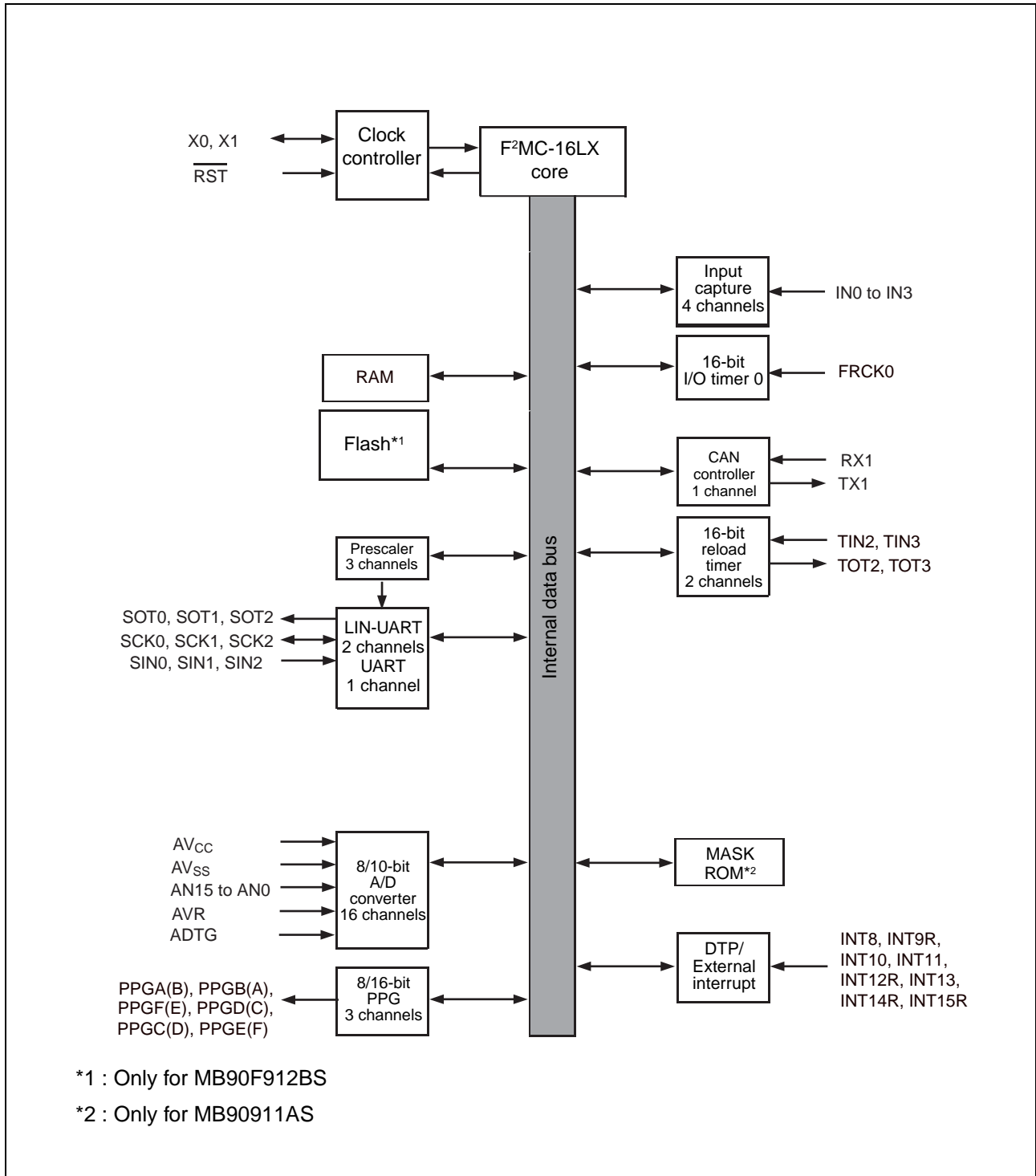

MEMORY MAP

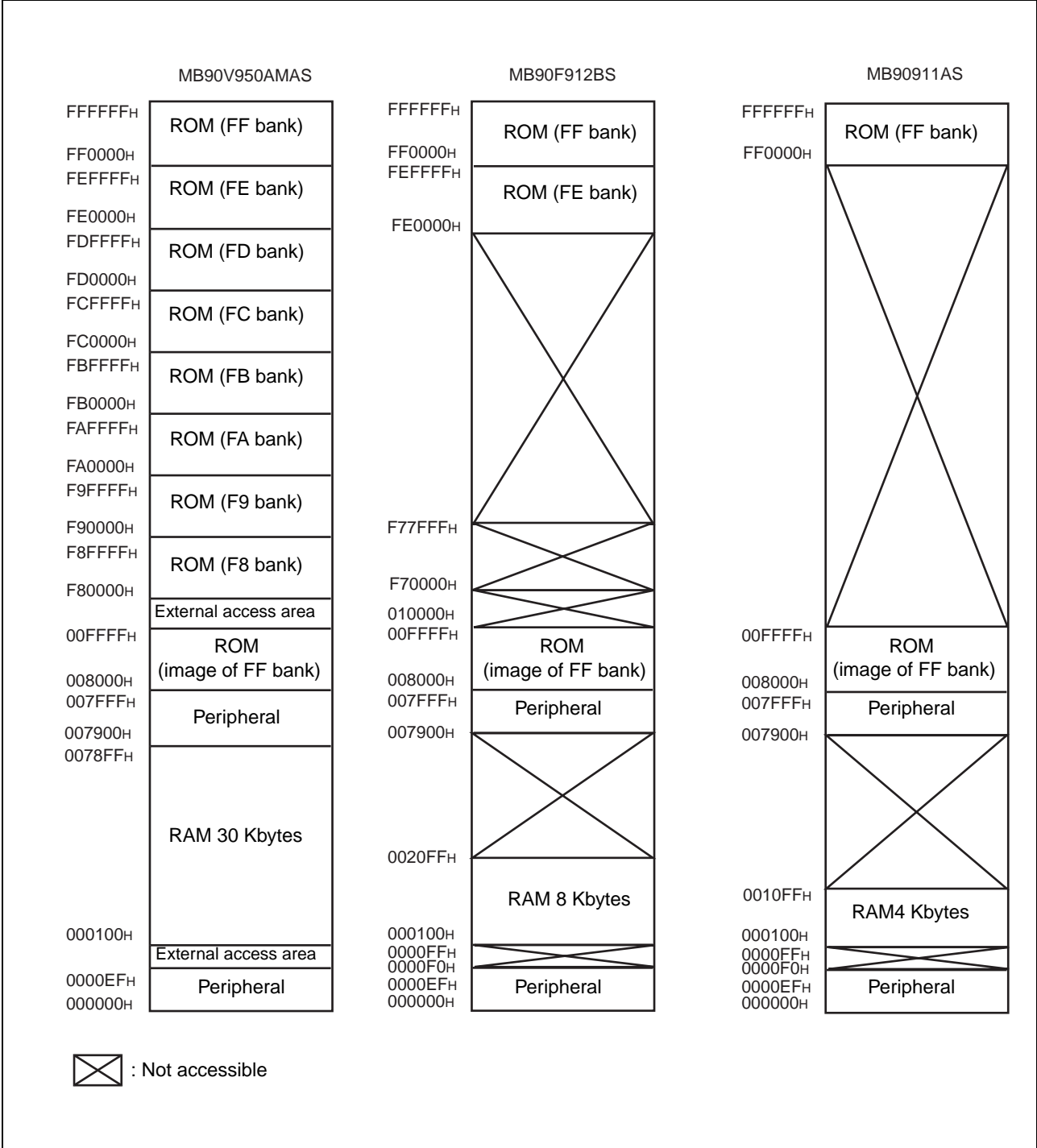

Note : The high-order portion of bank 00 gives the image of the FF bank ROM to make the small model of the C compiler effective. Since the low-order 16 bits are the same, the table in ROM can be referred without using the far specification in the pointer declaration.
 For example, an attempt to access 00C000H practically accesses the value at FFC000H in ROM.
 The ROM area in bank FF exceeds 32 Kbytes, and its entire image cannot be shown in bank 00.
 The image between FF8000H and FFFFFFFH is visible in bank 00, while the image between FF0000H and F7FFFFH is visible only in bank FF.

MB90910 Series

■ I/O MAP

Address	Register	Abbrevia- tion	Access	Resource name	Initial value
000000 _H , 000001 _H	Reserved				
000002 _H	Port 2 Data Register	PDR2	R/W	Port 2	XXXXXXXX _B
000003 _H	Reserved				
000004 _H	Port 4 Data Register	PDR4	R/W	Port 4	XXXXXXXX _B
000005 _H	Port 5 Data Register	PDR5	R/W	Port 5	XXXXXXXX _B
000006 _H	Port 6 Data Register	PDR6	R/W	Port 6	XXXXXXXX _B
000007 _H	Reserved				
000008 _H	Port 8 Data Register	PDR8	R/W	Port 8	XXXXXXXX _B
000009 _H , 00000A _H	Reserved				
00000B _H	Port 5 Analog Input Enable Register	ADER5	R/W	Port 5, A/D	1111111 _B
00000C _H	Port 6 Analog Input Enable Register	ADER6	R/W	Port 6, A/D	1111111 _B
00000D _H	Reserved				
00000E _H	Input Level Select Register 0	ILSR0	R/W	Ports	XXXXXXXX _B
00000F _H	Input Level Select Register 1	ILSR1	R/W	Ports	XXXX0XXX _B
000010 _H , 000011 _H	Reserved				
000012 _H	Port 2 Direction Register	DDR2	R/W	Port 2	0000000 _B
000013 _H	Reserved				
000014 _H	Port 4 Direction Register	DDR4	R/W	Port 4	0000000 _B
000015 _H	Port 5 Direction Register	DDR5	R/W	Port 5	0000000 _B
000016 _H	Port 6 Direction Register	DDR6	R/W	Port 6	0000000 _B
000017 _H	Reserved				
000018 _H	Port 8 Direction Register	DDR8	R/W	Port 8	0000000 _B
000019 _H	Reserved				
00001A _H	Port A Direction Register	DDRA	W	Port A	0000011 _B
00001B _H to 00001D _H	Reserved				
00001E _H	Port 2 Pull-up Control Register	PUCR2	R/W	Port 2	0000000 _B
00001F _H	Reserved				

(Continued)

MB90910 Series

Address	Register	Abbreviation	Access	Resource name	Initial value
000020 _H	Serial Mode Register 0	SMR0	W, R/W	UART0	00000000 _B
000021 _H	Serial Control Register 0	SCR0	W, R/W		00000000 _B
000022 _H	Reception/Transmission Data Register 0	RDR0/ TDR0	R/W		00000000 _B / 11111111 _B
000023 _H	Serial Status Register 0	SSR0	R, R/W		00001000 _B
000024 _H	Extended Communication Control Register 0	ECCR0	R, W, R/W		000000XX _B
000025 _H	Extended Status/Control Register 0	ESCR0	R/W		00000X00 _B
000026 _H	Baud Rate Generator Register 00	BGR00	R/W, R		00000000 _B
000027 _H	Baud Rate Generator Register 01	BGR01	R/W, R		00000000 _B
000028 _H	Serial Mode Register 1	SMR1	W, R/W	UART1	00000000 _B
000029 _H	Serial Control Register 1	SCR1	W, R/W		00000000 _B
00002A _H	Reception/Transmission Data Register 1	RDR1/ TDR1	R/W		00000000 _B / 11111111 _B
00002B _H	Serial Status Register 1	SSR1	R, R/W		00001000 _B
00002C _H	Extended Communication Control Register 1	ECCR1	R, W, R/W		000000XX _B
00002D _H	Extended Status/Control Register 1	ESCR1	R/W		00000X00 _B
00002E _H	Baud Rate Generator Register 10	BGR10	R/W, R		00000000 _B
00002F _H	Baud Rate Generator Register 11	BGR11	R/W, R		00000000 _B
000030 _H to 00003A _H	Reserved				
00003B _H	Address Detect Control Register 1	PACSR1	R/W	Address Match Detection 1	11000000 _B
00003C _H to 000043 _H	Reserved				
000044 _H	PPGA Operation Mode Control Register	PPGCA	W, R/W	16-bit PPG A/B	01000111 _B
000045 _H	PPGB Operation Mode Control Register	PPGCB	W, R/W		01000001 _B
000046 _H	PPGA/B Count Clock Select Register	PPGAB	R/W		00000010 _B
000047 _H	Reserved				
000048 _H	PPG C Operation Mode Control Register	PPGCC	W, R/W	16-bit PPG C/D	01000111 _B
000049 _H	PPG D Operation Mode Control Register	PPGCD	W, R/W		01000001 _B
00004A _H	PPG C/PPG D Count Clock Select Register	PPGCD	R/W		00000010 _B
00004B _H	Reserved				

(Continued)

MB90910 Series

Address	Register	Abbrevia- tion	Access	Resource name	Initial value
00004C _H	PPG E Operation Mode Control Register	PPGCE	W, R/W	16-bit PPG E/F	01000111 _B
00004D _H	PPG F Operation Mode Control Register	PPGCF	W, R/W		01000001 _B
00004E _H	PPG E/PPG F Count Clock Select Register	PPGEF	R/W		00000010 _B
00004F _H	Reserved				
000050 _H	Input Capture Control Status 0/1	ICS01	R/W	Input Capture 0/1	00000000 _B
000051 _H	Input Capture Edge 0/1	ICE01	R/W, R		111010XX _B
000052 _H	Input Capture Control Status 2/3	ICS23	R/W	Input Capture 2/3	00000000 _B
000053 _H	Input Capture Edge 2/3	ICE23	R		111111XX _B
000054 _H to 000063 _H	Reserved				
000064 _H	Timer Control Status 2	TMCSR2	R/W	16-bit Reload Timer 2	00000000 _B
000065 _H	Timer Control Status 2	TMCSR2	R/W		11110000 _B
000066 _H	Timer Control Status 3	TMCSR3	R/W	16-bit Reload Timer 3	00000000 _B
000067 _H	Timer Control Status 3	TMCSR3	R/W		11110000 _B
000068 _H	A/D Control Status 0	ADCS0	R/W	A/D Converter	00011110 _B
000069 _H	A/D Control Status 1	ADCS1	R/W, W		00000001 _B
00006A _H	A/D Data 0	ADCR0	R		00000000 _B
00006B _H	A/D Data 1	ADCR1	R		11111100 _B
00006C _H	A/D Converter Setting 0	ADSR0	R/W		00000000 _B
00006D _H	A/D Converter Setting 1	ADSR1	R/W		00000000 _B
00006E _H	Reserved				
00006F _H	ROM Mirror Function Select Register	ROMM	W	ROM Mirror	11111101 _B
000070 _H to 00007F _H	Reserved				
000080 _H to 00008F _H	Reserved for CAN Controller 1. Refer to "■ CAN CONTROLLERS"				
000090 _H to 00009D _H	Reserved				
00009E _H	Address Detect Control Register 0	PACSR0	R/W	Address Match Detection 0	11000000 _B

(Continued)

MB90910 Series

Address	Register	Abbrevia- tion	Access	Resource name	Initial value
00009F _H	Delayed Interrupt/Release Register	DIRR	R/W	Delayed Interrupt Generation module	11111110 _B
0000A0 _H	Low-power Consumption Mode Control Register	LPMCR	W, R/W	Low-Power Consumption Control Circuit	00011000 _B
0000A1 _H	Clock Selection Register	CKSCR	R, R/W	Low-Power consumption Control Circuit	11111100 _B
0000A2 _H to 0000A7 _H	Reserved				
0000A8 _H	Watchdog Timer Control Register	WDTC	R, W	Watchdog Timer	XXXXX111 _B
0000A9 _H	Timebase Timer Control Register	TBTC	W, R/W	Timebase Timer	11100100 _B
0000AA _H	Reserved				
0000AB _H to 0000AD _H	Reserved				
0000AE _H	Flash memory Control Status Register (Flash Devices only. Otherwise reserved)	FMCS	R, R/W	Flash Memory	000X0000 _B
0000AF _H	Reserved				
0000B0 _H	Interrupt Control Register 00	ICR00	W, R/W	Interrupt Control	00000111 _B
0000B1 _H	Interrupt Control Register 01	ICR01	W, R/W		00000111 _B
0000B2 _H	Interrupt Control Register 02	ICR02	W, R/W		00000111 _B
0000B3 _H	Interrupt Control Register 03	ICR03	W, R/W		00000111 _B
0000B4 _H	Interrupt Control Register 04	ICR04	W, R/W		00000111 _B
0000B5 _H	Interrupt Control Register 05	ICR05	W, R/W		00000111 _B
0000B6 _H	Interrupt Control Register 06	ICR06	W, R/W		00000111 _B
0000B7 _H	Interrupt Control Register 07	ICR07	W, R/W		00000111 _B
0000B8 _H	Interrupt Control Register 08	ICR08	W, R/W		00000111 _B
0000B9 _H	Interrupt Control Register 09	ICR09	W, R/W		00000111 _B
0000BA _H	Interrupt Control Register 10	ICR10	W, R/W		00000111 _B
0000BB _H	Interrupt Control Register 11	ICR11	W, R/W		00000111 _B
0000BC _H	Interrupt Control Register 12	ICR12	W, R/W		00000111 _B
0000BD _H	Interrupt Control Register 13	ICR13	W, R/W		00000111 _B
0000BE _H	Interrupt Control Register 14	ICR14	W, R/W		00000111 _B
0000BF _H	Interrupt Control Register 15	ICR15	W, R/W		00000111 _B
0000C0 _H	Reserved				

(Continued)

MB90910 Series

Address	Register	Abbreviation	Access	Resource name	Initial value
0000C1 _H	Reserved				
0000C2 _H	Reserved				
0000C3 _H to 0000C9 _H	Reserved				
0000CA _H	External Interrupt Enable 1	ENIR1	R/W	DTP/External Interrupt	00000000 _B
0000CB _H	External Interrupt Source 1	EIRR1	R/W		XXXXXXXX _B
0000CC _H	Detection Level Setting 1	ELVR1	R/W		00000000 _B
0000CD _H					00000000 _B
0000CE _H	External Interrupt Source Select	EISSR	R/W		00000000 _B
0000CF _H	PLL clock Control Register	PSCCR	W	PLL	11110000 _B
0000D0 _H to 0000D7 _H	Reserved				
0000D8 _H	Serial Mode Register 2	SMR2	W, R/W	UART2	00000000 _B
0000D9 _H	Serial Control Register 2	SCR2	W, R/W		00000000 _B
0000DA _H	Reception/Transmission Data Register 2	RDR2/ TDR2	R/W		00000000 _B / 11111111 _B
0000DB _H	Serial Status Register 2	SSR2	R, R/W		00001000 _B
0000DC _H	Extended Communication Control Register 2	ECCR2	R, W, R/W		000000XX _B
0000DD _H	Extended Status/Control Register 2	ESCR2	R/W		00000X00 _B
0000DE _H	Baud Rate Generator Register 20	BGR20	R/W, R		00000000 _B
0000DF _H	Baud Rate Generator Register 21	BGR21	R/W, R		00000000 _B
0000E0 _H to 0000FF _H	Reserved				
007900 _H to 007913 _H	Reserved				
007914 _H	Reload Register LA	PRLLA	R/W	16-bit PPG A/B	XXXXXXXX _B
007915 _H	Reload Register HA	PRLHA	R/W		XXXXXXXX _B
007916 _H	Reload Register LB	PRLLB	R/W		XXXXXXXX _B
007917 _H	Reload Register HB	PRLHB	R/W		XXXXXXXX _B
007918 _H	Reload Register LC	PRLLC	R/W	16-bit PPG C/D	XXXXXXXX _B
007919 _H	Reload Register HC	PRLHC	R/W		XXXXXXXX _B
00791A _H	Reload Register LD	PRLLD	R/W		XXXXXXXX _B
00791B _H	Reload Register HD	PRLHD	R/W		XXXXXXXX _B

(Continued)

MB90910 Series

Address	Register	Abbrevia- tion	Access	Resource name	Initial value
00791C _H	Reload Register LE	PRLLE	R/W	16-bit PPG E/F	XXXXXXXX _B
00791D _H	Reload Register HE	PRLHE	R/W		XXXXXXXX _B
00791E _H	Reload Register LF	PRLLF	R/W		XXXXXXXX _B
00791F _H	Reload Register HF	PRLHF	R/W		XXXXXXXX _B
007920 _H	Input Capture Register 0	IPCP0	R	Input Capture 0/1*	00000000 _B
007921 _H	Input Capture Register 0	IPCP0	R		00000000 _B
007922 _H	Input Capture Register 1	IPCP1	R		00000000 _B
007923 _H	Input Capture Register 1	IPCP1	R		00000000 _B
007924 _H	Input Capture Register 2	IPCP2	R	Input Capture 2/3*	00000000 _B
007925 _H	Input Capture Register 2	IPCP2	R		00000000 _B
007926 _H	Input Capture Register 3	IPCP3	R		00000000 _B
007927 _H	Input Capture Register 3	IPCP3	R		00000000 _B
007928 _H to 00793F _H	Reserved				
007940 _H	Timer Data Register 0	TCDT0	R/W	I/O Timer 0	00000000 _B
007941 _H	Timer Data Register 0	TCDT0	R/W		00000000 _B
007942 _H	Timer Control Status Register 0	TCCSL0	R/W		00000000 _B
007943 _H	Timer Control Status Register 0	TCCSH0	R/W		01100000 _B
007944 _H to 00794B _H	Reserved				
00794C _H	Timer Register 2/Reload Register 2	TMR2/	R/W	16-bit Reload Timer 2	XXXXXXXX _B
00794D _H		TMRLR2	R/W		XXXXXXXX _B
00794E _H	Timer Register 3/Reload Register 3	TMR3/	R/W	16-bit Reload Timer 3	XXXXXXXX _B
00794F _H		TMRLR3	R/W		XXXXXXXX _B
007950 _H to 00795F _H	Reserved				
007960 _H	Reserved				
007961 _H to 00796D _H	Reserved				
00796E _H	CAN Direct Mode Register (MB90V950AMAS only)	CDMR	R/W	CAN clock sync	11111110 _B
00796F _H to 0079A1 _H	Reserved				

(Continued)

MB90910 Series

Address	Register	Abbrevia- tion	Access	Resource name	Initial value
0079A2 _H	Flash Write Control Register 0	FWR0	R/W	Flash	00000000 _B
0079A3 _H	Flash Write Control Register 1	FWR1	R/W		00000000 _B
0079A4 _H to 0079B1 _H	Reserved				
0079B2 _H	Reserved				
0079B3 _H to 0079B7 _H	Reserved				
0079B8 _H	Reserved				
0079B9 _H	Reserved				
0079BA _H	Reserved				
0079BB _H	Reserved				
0079BC _H	Reserved				
0079BD _H	Reserved				
0079BE _H	Reserved				
0079BF _H	Reserved				
0079C0 _H to 0079DF _H	Reserved				
0079E0 _H	Detect Address Setting Register 0	PADR0	R/W	Address Match Detection 0	XXXXXXXX _B
0079E1 _H	Detect Address Setting Register 0	PADR0	R/W		XXXXXXXX _B
0079E2 _H	Detect Address Setting Register 0	PADR0	R/W		XXXXXXXX _B
0079E3 _H	Detect Address Setting Register 1	PADR1	R/W		XXXXXXXX _B
0079E4 _H	Detect Address Setting Register 1	PADR1	R/W		XXXXXXXX _B
0079E5 _H	Detect Address Setting Register 1	PADR1	R/W		XXXXXXXX _B
0079E6 _H	Detect Address Setting Register 2	PADR2	R/W		XXXXXXXX _B
0079E7 _H	Detect Address Setting Register 2	PADR2	R/W		XXXXXXXX _B
0079E8 _H	Detect Address Setting Register 2	PADR2	R/W		XXXXXXXX _B
0079E9 _H to 0079EF _H	Reserved				

(Continued)

(Continued)

Address	Register	Abbreviation	Access	Resource name	Initial value
0079F0 _H	Detect Address Setting Register 3	PADR3	R/W	Address Match Detection 1	XXXXXXXX _B
0079F1 _H	Detect Address Setting Register 3	PADR3	R/W		XXXXXXXX _B
0079F2 _H	Detect Address Setting Register 3	PADR3	R/W		XXXXXXXX _B
0079F3 _H	Detect Address Setting Register 4	PADR4	R/W		XXXXXXXX _B
0079F4 _H	Detect Address Setting Register 4	PADR4	R/W		XXXXXXXX _B
0079F5 _H	Detect Address Setting Register 4	PADR4	R/W		XXXXXXXX _B
0079F6 _H	Detect Address Setting Register 5	PADR5	R/W		XXXXXXXX _B
0079F7 _H	Detect Address Setting Register 5	PADR5	R/W		XXXXXXXX _B
0079F8 _H	Detect Address Setting Register 5	PADR5	R/W		XXXXXXXX _B
0079F9 _H to 007BFF _H	Reserved				
007C00 _H to 007CFF _H	Reserved for CAN Controller. Refer to "■ CAN CONTROLLERS"				
007D00 _H to 007DFF _H	Reserved for CAN Controller. Refer to "■ CAN CONTROLLERS"				
007E00 _H to 007FFF _H	Reserved				

* : The initial value of MB90V950AMAS is XXXXXXXX_B.

- Notes :
- Initial value of "X" represents undefined value.
 - Do not write to reserved address in I/O map. A read access to reserved addresses results in reading "X".

MB90910 Series

■ CAN CONTROLLERS

- Conforms to CAN Specification Ver 2.0 Part A and Part B
 - Supports transmission/reception in standard frame and extended frame formats
- Supports transmitting of data frames by receiving remote frames
- 16 transmitting/receiving message buffers
 - 29-bit ID and 8-byte data
 - Multi-level message buffer configuration
- Provides full-bit comparison, full-bit mask, acceptance register 0/acceptance register 1 for each message buffer as ID acceptance mask
 - 2 acceptance mask registers in either standard frame format or extended frame formats
- Bit rate programmable from 10 kbps/s to 1 Mbps/s (when input clock is at 16 MHz)

List of Control Registers (1)

Address	Register	Abbreviation	Access	Initial Value
CAN1				
000080 _H	Message buffer valid register	BVALR	R/W	00000000 00000000 _B
000081 _H				
000082 _H	Transmit request register	TREQR	R/W	00000000 00000000 _B
000083 _H				
000084 _H	Transmit cancel register	TCANR	W	00000000 00000000 _B
000085 _H				
000086 _H	Transmission complete register	TCR	R/W	00000000 00000000 _B
000087 _H				
000088 _H	Receive complete register	RCR	R/W	00000000 00000000 _B
000089 _H				
00008A _H	Remote request receiving register	RRTRR	R/W	00000000 00000000 _B
00008B _H				
00008C _H	Receive overrun register	ROVRR	R/W	00000000 00000000 _B
00008D _H				
00008E _H	Reception interrupt enable register	RIER	R/W	00000000 00000000 _B
00008F _H				

List of Control Registers (2)

Address	Register	Abbreviation	Access	Initial Value
CAN1				
007D00 _H	Control status register	CSR	R/W, W R/W, R	0XXXX0X1 00XXX000 _B
007D01 _H				
007D02 _H	Last event indicator register	LEIR	R/W	000X0000 XXXXXXXX _B
007D03 _H				
007D04 _H	Receive and transmit error counter	RTEC	R	00000000 00000000 _B
007D05 _H				
007D06 _H	Bit timing register	BTR	R/W	11111111 X1111111 _B
007D07 _H				
007D08 _H	IDE register	IDER	R/W	XXXXXXXX XXXXXXXX _B
007D09 _H				
007D0A _H	Transmit RTR register	TRTRR	R/W	00000000 00000000 _B
007D0B _H				
007D0C _H	Remote frame receive waiting register	RFWTR	R/W	XXXXXXXX XXXXXXXX _B
007D0D _H				
007D0E _H	Transmit interrupt enable register	TIER	R/W	00000000 00000000 _B
007D0F _H				
007D10 _H	Acceptance mask select register	AMSR	R/W	XXXXXXXX XXXXXXXX _B
007D11 _H				XXXXXXXX XXXXXXXX _B
007D12 _H				XXXXXXXX XXXXXXXX _B
007D13 _H				XXXXXXXX XXXXXXXX _B
007D14 _H	Acceptance mask register 0	AMR0	R/W	XXXXXXXX XXXXXXXX _B
007D15 _H				XXXXXXXX XXXXXXXX _B
007D16 _H				XXXXXXXX XXXXXXXX _B
007D17 _H				XXXXXXXX XXXXXXXX _B
007D18 _H	Acceptance mask register 1	AMR1	R/W	XXXXXXXX XXXXXXXX _B
007D19 _H				XXXXXXXX XXXXXXXX _B
007D1A _H				XXXXXXXX XXXXXXXX _B
007D1B _H				XXXXXXXX XXXXXXXX _B

MB90910 Series

List of Message Buffers (ID Registers)

Address	Register	Abbreviation	Access	Initial Value
CAN1				
007C00 _H to 007C1F _H	General-purpose RAM	—	R/W	XXXXXXXX _B to XXXXXXXX _B
007C20 _H	ID register 0	IDR0	R/W	XXXXXXXX XXXXXXXX _B
007C21 _H				
007C22 _H				XXXXXXXX XXXXXXXX _B
007C23 _H				
007C24 _H	ID register 1	IDR1	R/W	XXXXXXXX XXXXXXXX _B
007C25 _H				
007C26 _H				XXXXXXXX XXXXXXXX _B
007C27 _H				
007C28 _H	ID register 2	IDR2	R/W	XXXXXXXX XXXXXXXX _B
007C29 _H				
007C2A _H				XXXXXXXX XXXXXXXX _B
007C2B _H				
007C2C _H	ID register 3	IDR3	R/W	XXXXXXXX XXXXXXXX _B
007C2D _H				
007C2E _H				XXXXXXXX XXXXXXXX _B
007C2F _H				
007C30 _H	ID register 4	IDR4	R/W	XXXXXXXX XXXXXXXX _B
007C31 _H				
007C32 _H				XXXXXXXX XXXXXXXX _B
007C33 _H				
007C34 _H	ID register 5	IDR5	R/W	XXXXXXXX XXXXXXXX _B
007C35 _H				
007C36 _H				XXXXXXXX XXXXXXXX _B
007C37 _H				
007C38 _H	ID register 6	IDR6	R/W	XXXXXXXX XXXXXXXX _B
007C39 _H				
007C3A _H				XXXXXXXX XXXXXXXX _B
007C3B _H				
007C3C _H	ID register 7	IDR7	R/W	XXXXXXXX XXXXXXXX _B
007C3D _H				
007C3E _H				XXXXXXXX XXXXXXXX _B
007C3F _H				

(Continued)

(Continued)

Address	Register	Abbreviation	Access	Initial Value
CAN1				
007C40 _H	ID register 8	IDR8	R/W	XXXXXXXX XXXXXXXX _B
007C41 _H				
007C42 _H				XXXXXXXX XXXXXXXX _B
007C43 _H				
007C44 _H	ID register 9	IDR9	R/W	XXXXXXXX XXXXXXXX _B
007C45 _H				
007C46 _H				XXXXXXXX XXXXXXXX _B
007C47 _H				
007C48 _H	ID register 10	IDR10	R/W	XXXXXXXX XXXXXXXX _B
007C49 _H				
007C4A _H				XXXXXXXX XXXXXXXX _B
007C4B _H				
007C4C _H	ID register 11	IDR11	R/W	XXXXXXXX XXXXXXXX _B
007C4D _H				
007C4E _H				XXXXXXXX XXXXXXXX _B
007C4F _H				
007C50 _H	ID register 12	IDR12	R/W	XXXXXXXX XXXXXXXX _B
007C51 _H				
007C52 _H				XXXXXXXX XXXXXXXX _B
007C53 _H				
007C54 _H	ID register 13	IDR13	R/W	XXXXXXXX XXXXXXXX _B
007C55 _H				
007C56 _H				XXXXXXXX XXXXXXXX _B
007C57 _H				
007C58 _H	ID register 14	IDR14	R/W	XXXXXXXX XXXXXXXX _B
007C59 _H				
007C5A _H				XXXXXXXX XXXXXXXX _B
007C5B _H				
007C5C _H	ID register 15	IDR15	R/W	XXXXXXXX XXXXXXXX _B
007C5D _H				
007C5E _H				XXXXXXXX XXXXXXXX _B
007C5F _H				

MB90910 Series

List of Message Buffers (DLC Registers and Data Registers)

Address	Register	Abbreviation	Access	Initial Value
CAN1				
007C60 _H	DLC register 0	DLCR0	R/W	XXXXXXXX _B
007C61 _H				
007C62 _H	DLC register 1	DLCR1	R/W	XXXXXXXX _B
007C63 _H				
007C64 _H	DLC register 2	DLCR2	R/W	XXXXXXXX _B
007C65 _H				
007C66 _H	DLC register 3	DLCR3	R/W	XXXXXXXX _B
007C67 _H				
007C68 _H	DLC register 4	DLCR4	R/W	XXXXXXXX _B
007C69 _H				
007C6A _H	DLC register 5	DLCR5	R/W	XXXXXXXX _B
007C6B _H				
007C6C _H	DLC register 6	DLCR6	R/W	XXXXXXXX _B
007C6D _H				
007C6E _H	DLC register 7	DLCR7	R/W	XXXXXXXX _B
007C6F _H				
007C70 _H	DLC register 8	DLCR8	R/W	XXXXXXXX _B
007C71 _H				
007C72 _H	DLC register 9	DLCR9	R/W	XXXXXXXX _B
007C73 _H				
007C74 _H	DLC register 10	DLCR10	R/W	XXXXXXXX _B
007C75 _H				
007C76 _H	DLC register 11	DLCR11	R/W	XXXXXXXX _B
007C77 _H				
007C78 _H	DLC register 12	DLCR12	R/W	XXXXXXXX _B
007C79 _H				
007C7A _H	DLC register 13	DLCR13	R/W	XXXXXXXX _B
007C7B _H				
007C7C _H	DLC register 14	DLCR14	R/W	XXXXXXXX _B
007C7D _H				
007C7E _H	DLC register 15	DLCR15	R/W	XXXXXXXX _B
007C7F _H				

(Continued)

MB90910 Series

Address	Register	Abbreviation	Access	Initial Value
CAN1				
007C80 _H to 007C87 _H	Data register 0 (8 bytes)	DTR0	R/W	XXXXXXXX _B to XXXXXXXX _B
007C88 _H to 007C8F _H	Data register 1 (8 bytes)	DTR1	R/W	XXXXXXXX _B to XXXXXXXX _B
007C90 _H to 007C97 _H	Data register 2 (8 bytes)	DTR2	R/W	XXXXXXXX _B to XXXXXXXX _B
007C98 _H to 007C9F _H	Data register 3 (8 bytes)	DTR3	R/W	XXXXXXXX _B to XXXXXXXX _B
007CA0 _H to 007CA7 _H	Data register 4 (8 bytes)	DTR4	R/W	XXXXXXXX _B to XXXXXXXX _B
007CA8 _H to 007CAF _H	Data register 5 (8 bytes)	DTR5	R/W	XXXXXXXX _B to XXXXXXXX _B
007CB0 _H to 007CB7 _H	Data register 6 (8 bytes)	DTR6	R/W	XXXXXXXX _B to XXXXXXXX _B
007CB8 _H to 007CBF _H	Data register 7 (8 bytes)	DTR7	R/W	XXXXXXXX _B to XXXXXXXX _B
007CC0 _H to 007CC7 _H	Data register 8 (8 bytes)	DTR8	R/W	XXXXXXXX _B to XXXXXXXX _B
007CC8 _H to 007CCF _H	Data register 9 (8 bytes)	DTR9	R/W	XXXXXXXX _B to XXXXXXXX _B
007CD0 _H to 007CD7 _H	Data register 10 (8 bytes)	DTR10	R/W	XXXXXXXX _B to XXXXXXXX _B
007CD8 _H to 007CDF _H	Data register 11 (8 bytes)	DTR11	R/W	XXXXXXXX _B to XXXXXXXX _B
007CE0 _H to 007CE7 _H	Data register 12 (8 bytes)	DTR12	R/W	XXXXXXXX _B to XXXXXXXX _B
007CE8 _H to 007CEF _H	Data register 13 (8 bytes)	DTR13	R/W	XXXXXXXX _B to XXXXXXXX _B

(Continued)

MB90910 Series

(Continued)

Address	Register	Abbreviation	Access	Initial Value
CAN1				
007CF0 _H to 007CF7 _H	Data register 14 (8 bytes)	DTR14	R/W	XXXXXXXX _B to XXXXXXXX _B
007CF8 _H to 007CFF _H	Data register 15 (8 bytes)	DTR15	R/W	XXXXXXXX _B to XXXXXXXX _B

■ INTERRUPT FACTORS, INTERRUPT VECTORS, INTERRUPT CONTROL REGISTER

Interrupt cause	EI ² OS corresponding	Interrupt vector		Interrupt control register	
		Number	Address	Number	Address
Reset	N	#08	FFFFDC _H	—	—
INT9 instruction	N	#09	FFFFD8 _H	—	—
Exception	N	#10	FFFFD4 _H	—	—
Reserved	N	#11	FFFFD0 _H	ICR00	0000B0 _H
Reserved	N	#12	FFFFCC _H		
CAN 1 reception	N	#13	FFFFC8 _H	ICR01	0000B1 _H
CAN 1 transmission/node status	N	#14	FFFFC4 _H		
Reserved	N	#15	FFFFC0 _H	ICR02	0000B2 _H
Reserved	N	#16	FFFFBC _H		
Reserved	N	#17	FFFFB8 _H	ICR03	0000B3 _H
Reserved	N	#18	FFFFB4 _H		
16-bit reload timer 2	Y1	#19	FFFFB0 _H	ICR04	0000B4 _H
16-bit reload timer 3	Y1	#20	FFFFAC _H		
Reserved	N	#21	FFFFA8 _H	ICR05	0000B5 _H
Reserved	N	#22	FFFFA4 _H		
PPG C/D	N	#23	FFFFA0 _H	ICR06	0000B6 _H
PPG A/B/E/F	N	#24	FFFF9C _H		
Timebase timer	N	#25	FFFF98 _H	ICR07	0000B7 _H
External interrupt 8 to 11	Y1	#26	FFFF94 _H		
Reserved	N	#27	FFFF90 _H	ICR08	0000B8 _H
External interrupt 12 to 15	Y1	#28	FFFF8C _H		
A/D converter	Y1	#29	FFFF88 _H	ICR09	0000B9 _H
I/O timer 0	N	#30	FFFF84 _H		
Reserved	N	#31	FFFF80 _H	ICR10	0000BA _H
Reserved	N	#32	FFFF7C _H		
Input capture 0 to 3	Y1	#33	FFFF78 _H	ICR11	0000BB _H
Reserved	N	#34	FFFF74 _H		
UART 0 reception	Y2	#35	FFFF70 _H	ICR12	0000BC _H
UART 0 transmission	Y1	#36	FFFF6C _H		
UART 1 reception	Y2	#37	FFFF68 _H	ICR13	0000BD _H
UART 1 transmission	Y1	#38	FFFF64 _H		

(Continued)

MB90910 Series

(Continued)

Interrupt cause	EI ² OS corresponding	Interrupt vector		Interrupt control register	
		Number	Address	Number	Address
UART 2 reception	Y2	#39	FFFF60H	ICR14	0000BEH
UART 2 transmission	Y1	#40	FFFF5CH		
Flash memory	N	#41	FFFF58H	ICR15	0000BFH
Delayed interrupt generation module	N	#42	FFFF54H		

Y1 : Usable

Y2 : Usable, with EI²OS stop function

N : Unusable

- Notes :
- The peripheral resources sharing the ICR register have the same interrupt level.
 - When the peripheral resources sharing the ICR register use extended intelligent I/O service, only one can use extended intelligent I/O service at a time.
 - When either of the 2 peripheral resources sharing the ICR register specifies extended intelligent I/O service, the other one cannot use interrupts.

■ ELECTRICAL CHARACTERISTICS

1. Absolute Maximum Ratings

Parameter	Symbol	Rating		Unit	Remarks
		Min	Max		
Power supply voltage*1	V _{CC}	V _{SS} - 0.3	V _{SS} + 6.0	V	
	AV _{CC}	V _{SS} - 0.3	V _{SS} + 6.0	V	V _{CC} = AV _{CC} *2
	AVR	V _{SS} - 0.3	V _{SS} + 6.0	V	AV _{CC} ≥ AVR*2
Input voltage*1	V _I	V _{SS} - 0.3	V _{SS} + 6.0	V	*3
Output voltage*1	V _O	V _{SS} - 0.3	V _{SS} + 6.0	V	*3
Maximum clamp current	I _{CLAMP}	-2.0	+2.0	mA	*6
Total Maximum clamp current	Σ I _{CLAMP}	—	40	mA	*6
“L” level maximum output current	I _{OL1}	—	15	mA	*4
	I _{OL2}	—	40	mA	*5
“L” level average output current	I _{OLAV1}	—	4	mA	*4
	I _{OLAV2}	—	30	mA	*5
“L” level maximum overall output current	ΣI _{OL1}	—	125	mA	*4
	ΣI _{OL2}	—	160	mA	*5
“L” level average overall output current	ΣI _{OLAV1}	—	40	mA	*4 +105 °C < T _A ≤ +125 °C
	ΣI _{OLAV2}				*5 +105 °C < T _A ≤ +125 °C
	ΣI _{OLAV1}	—	40	mA	*4 -40 °C ≤ T _A ≤ +105 °C
	ΣI _{OLAV2}				*5 -40 °C ≤ T _A ≤ +105 °C
“H” level maximum output current	I _{OH1}	—	-15	mA	*4
	I _{OH2}	—	-40	mA	*5
“H” level average output current	I _{OHAV1}	—	-4	mA	*4
	I _{OHAV2}	—	-30	mA	*5
“H” level maximum overall output current	ΣI _{OH1}	—	-125	mA	*4
	ΣI _{OH2}	—	-160	mA	*5
“H” level average overall output current	ΣI _{OHAV1}	—	-40	mA	*4 +105 °C < T _A ≤ +125 °C
	ΣI _{OHAV2}				*5 +105 °C < T _A ≤ +125 °C
	ΣI _{OHAV1}	—	-40	mA	*4 -40 °C ≤ T _A ≤ +105 °C
	ΣI _{OHAV2}				*5 -40 °C ≤ T _A ≤ +105 °C
Power consumption	P _D	—	420	mW	
Operating temperature	T _A	-40	+105	°C	
		-40	+125	°C	*7
Storage temperature	T _{STG}	-55	+150	°C	

(Continued)

MB90910 Series

(Continued)

- *1 : This parameter is based on $V_{SS} = AV_{SS} = 0\text{ V}$.
- *2 : Set AV_{CC} and V_{CC} to the same voltage. Make sure that AV_{CC} does not exceed V_{CC} and that the voltage at the analog inputs does not exceed AV_{CC} when the power is switched on.
- *3 : V_I and V_O should not exceed $V_{CC} + 0.3\text{ V}$. V_I should not exceed the specified ratings. However, if the maximum current to/from an input is limited by some means with external components, the I_{CLAMP} rating supersedes the V_I rating.
- *4 : Applicable to pins : P24 to P27, P40 to P44, P50 to P57, P60 to P67, P80, P82 to P87
- *5 : Applicable to pins : P20 to P23
- *6 : Applicable to pins : P20 to P27, P40 to P44, P50 to P55, P57, P60 to P67, P80, P82 to P87
 - Use within recommended operating conditions.
 - Use at DC voltage (current) .
 - The +B signal should always be applied a connecting limit resistance between the +B signal and the microcontroller.
 - The value of the limiting resistance should be set so that when the +B signal is applied the input current to the microcontroller pin does not exceed rated values, either instantaneously or for prolonged periods.
 - Note that when the microcontroller drive current is low, such as in the power saving modes, the +B input potential may pass through the protective diode and increase the potential at the V_{CC} pin, and this may affect other devices.
 - Note that if a +B signal is inputted when the microcontroller power supply is off (not fixed at 0 V) , the power supply is provided from the pins, so that incomplete operation may result.
 - Note that if the +B input is applied during power-on, the power supply is provided from the pins and the resulting power supply voltage may not be sufficient to operate the power-on reset.
 - Care must be taken not to leave the +B input pin open.
 - Recommended circuit sample :

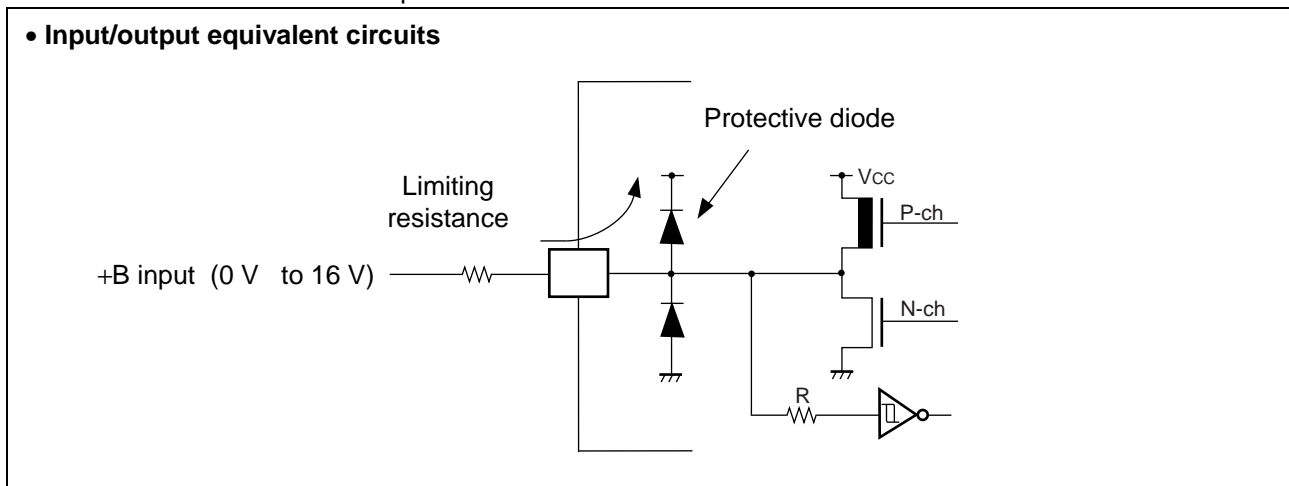

- *7 : If used exceeding $T_A = +105\text{ }^\circ\text{C}$, please consult with us due to the restricted reliability.
It is ensured to write/erase data to the Flash memory between $T_A = -40\text{ }^\circ\text{C}$ and $+105\text{ }^\circ\text{C}$.

WARNING: Semiconductor devices can be permanently damaged by application of stress (voltage, current, temperature, etc.) in excess of absolute maximum ratings. Do not exceed these ratings.

2. Recommended Conditions

($V_{SS} = AV_{SS} = 0\text{ V}$)

Parameter	Symbol	Value			Unit	Remarks
		Min	Typ	Max		
Power supply voltage	V_{CC}, AV_{CC}	3.0	5.0	5.5	V	Under normal operation
		2.6	—	5.5	V	Maintains RAM data in stop mode
Smoothing capacitor	C_S	0.1	—	1.0	μF	Use a ceramic capacitor or comparable capacitor of the AC characteristics. Bypass capacitor at the V_{CC} pin should be greater than this capacitor.
Operating temperature	T_A	-40	—	+105	$^{\circ}\text{C}$	
		-40	—	+125	$^{\circ}\text{C}$	*

* : For the restricted reliability, contact us if use the devices over $T_A = +105\text{ }^{\circ}\text{C}$.
It is ensured to write/erase data to the Flash memory between $T_A = -40\text{ }^{\circ}\text{C}$ and $+105\text{ }^{\circ}\text{C}$.

• C Pin Connection Diagram

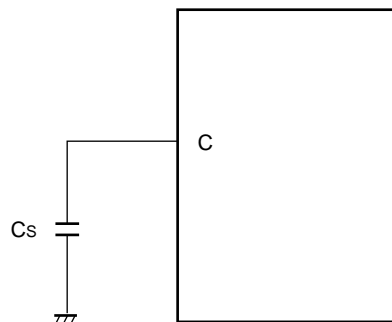

WARNING: The recommended operating conditions are required in order to ensure the normal operation of the semiconductor device. All of the device's electrical characteristics are warranted when the device is operated within these ranges.

Always use semiconductor devices within their recommended operating condition ranges. Operation outside these ranges may adversely affect reliability and could result in device failure.

No warranty is made with respect to uses, operating conditions, or combinations not represented on the data sheet. Users considering application outside the listed conditions are advised to contact their representatives beforehand.

MB90910 Series

3. DC Characteristics

Parameter	Symbol	Pin name	Condition	Value			Unit	Remarks
				Min	Typ	Max		
Input "H" voltage	V_{IHS}	—	—	$0.8 V_{CC}$	—	$V_{CC} + 0.3$	V	Pin inputs if CMOS hysteresis input levels are selected
	V_{IHA}	—	—	$0.8 V_{CC}$	—	$V_{CC} + 0.3$	V	Pin inputs if Automotive input levels are selected
	V_{IHS}	P50, P82, P85	—	$0.7 V_{CC}$	—	$V_{CC} + 0.3$	V	Pin inputs if CMOS hysteresis input levels are selected
	V_{IHR}	\overline{RST}	—	$0.8 V_{CC}$	—	$V_{CC} + 0.3$	V	\overline{RST} input pin (CMOS hysteresis)
	V_{IHM}	MD0 to MD2	—	$V_{CC} - 0.3$	—	$V_{CC} + 0.3$	V	MD input pin
Input "L" voltage	V_{ILS}	—	—	$V_{SS} - 0.3$	—	$0.2 V_{CC}$	V	Pin inputs if CMOS hysteresis input levels are selected
	V_{ILA}	—	—	$V_{SS} - 0.3$	—	$0.5 V_{CC}$	V	Pin inputs if Automotive input levels are selected
	V_{ILS}	P50, P82, P85	—	$V_{SS} - 0.3$	—	$0.3 V_{CC}$	V	Pin inputs if CMOS hysteresis input levels are selected
	V_{ILR}	\overline{RST}	—	$V_{SS} - 0.3$	—	$0.2 V_{CC}$	V	\overline{RST} input pin (CMOS hysteresis)
	V_{ILM}	MD0 to MD2	—	$V_{SS} - 0.3$	—	$V_{SS} + 0.3$	V	MD input pin
Output "H" voltage	V_{OH}	Other than P20 to P23	$V_{CC} = 4.5 V$, $I_{OH} = -4.0 mA$	$V_{CC} - 0.5$	—	—	V	
	V_{OHI}	P20 to P23	$V_{CC} = 4.5 V$, $I_{OH} = -14.0 mA$	$V_{CC} - 0.5$	—	—	V	MASK ROM products and Evaluation products only
Output "L" voltage	V_{OL}	Other than P20 to P23	$V_{CC} = 4.5 V$, $I_{OL} = 4.0 mA$	—	—	0.4	V	
	V_{OLI}	P20 to P23	$V_{CC} = 4.5 V$, $I_{OL} = 20.0 mA$	—	—	0.4	V	MASK ROM products and Evaluation products only
Input leak current	I_{IL}	—	$V_{CC} = 5.5 V$, $V_{SS} < V_i < V_{CC}$	-3	—	+3	μA	
Pull-up resistance	R_{UP}	P20 to P27, \overline{RST}	—	25	50	100	k Ω	
Pull-down resistance	R_{DOWN}	MD2	—	25	50	100	k Ω	MASK ROM products and Evaluation products only

(Continued)

(Continued)

Parameter	Symbol	Pin name	Condition	Value			Unit	Remarks
				Min	Typ	Max		
Power supply current*	I _{CC}	V _{CC}	V _{CC} = 5.0 V, Internal frequency : 32 MHz, At normal operation.	—	30	40	mA	
			V _{CC} = 5.0 V, Internal frequency : 24 MHz, At normal operation.	—	22.5	30	mA	
			V _{CC} = 5.0 V, Internal frequency : 2 MHz, At normal operation.	—	3	7	mA	
			V _{CC} = 5.0 V, Internal frequency : 32 MHz, At writing Flash memory.	—	50	65	mA	
			V _{CC} = 5.0 V, Internal frequency : 32 MHz, At erasing Flash memory.	—	50	65	mA	
	I _{CCS}		V _{CC} = 5.0 V, Internal frequency : 32 MHz, At sleep mode.	—	13	23	mA	
	I _{CTS}		V _{CC} = 5.0 V, Internal frequency : 2 MHz, At main timer mode	—	0.3	0.9	mA	
	I _{CTSPLL8}		V _{CC} = 5.0 V, Internal frequency : 32 MHz, At PLL timer mode, External frequency = 4 MHz	—	4	7	mA	
I _{CCH}	V _{CC} = 5.0 V, At stop mode, T _A = +25°C	—	25	100	μA			
Input capacity	C _{IN}	Other than AV _{CC} , AV _{SS} , AVR, V _{CC} , V _{SS} , C	—	5	15	pF		

* : The power supply current is measured with an external clock.

MB90910 Series

4. AC Characteristics

(1) Clock Timing

Parameter	Symbol	Pin name	Value			Unit	Remarks
			Min	Typ	Max		
Clock frequency	f _c	X0, X1	3	—	16	MHz	1/2 when PLL stops, When using an oscillation circuit
			4	—	16	MHz	PLL × 1, When using an oscillation circuit
			4	—	16	MHz	PLL × 2, When using an oscillation circuit
			4	—	10	MHz	PLL × 3, When using an oscillation circuit
			4	—	8	MHz	PLL × 4, When using an oscillation circuit
			4	—	5	MHz	PLL × 6, When using an oscillation circuit
			4	—	4	MHz	PLL × 8, When using an oscillation circuit
Clock cycle time	t _{cYL}	X0, X1	62.5	—	333	ns	When using an oscillation circuit
Internal operating clock frequency (machine clock)	f _{CP}	—	1.5	—	32	MHz	When using main clock
Internal operating clock cycle time (machine clock)	t _{CP}	—	31.25	—	666	ns	When using main clock

• When using an oscillation circuit

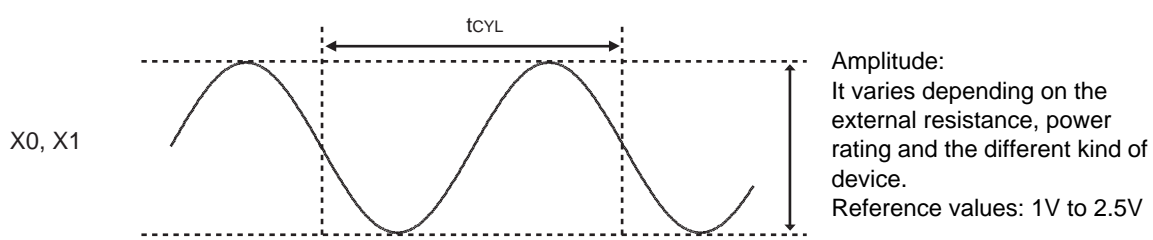

Note : The amplitude of MB90V950AMAS is the same as V_{CC}.

• Guaranteed PLL Operation Range

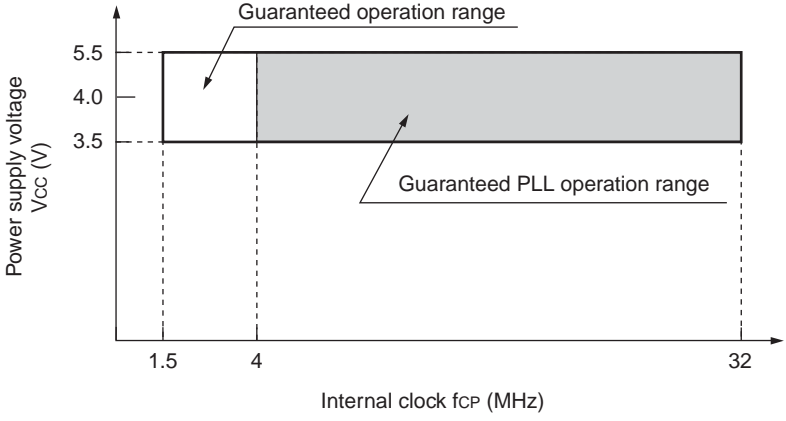

Guaranteed operation range of MB90910 series

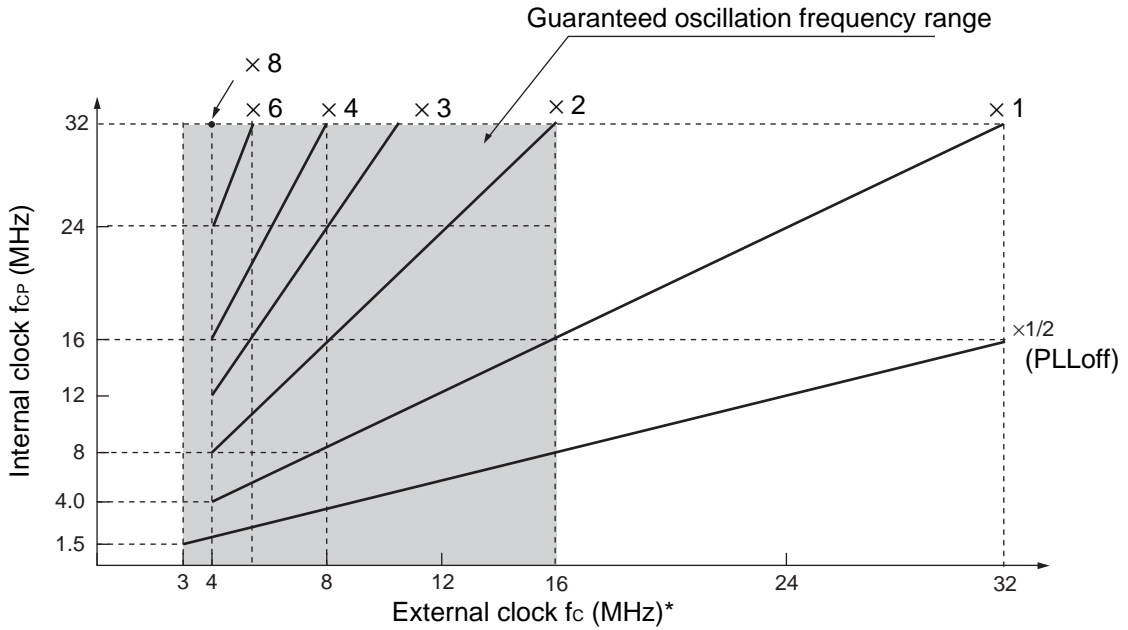

* : When using the oscillation circuit, the maximum oscillation clock frequency is 16 MHz.

MB90910 Series

(2) Reset Standby Input

Parameter	Symbol	Pin name	Value		Unit	Remarks
			Min	Max		
Reset input time	t _{RSTL}	$\overline{\text{RST}}$	500	—	ns	Under normal operation
			Oscillation time of oscillator* + 100 μs		μs	In stop mode
			100	—	μs	In timebase timer mode

* : Oscillation time of oscillator is the time that the amplitude reaches 90%. In the crystal oscillator, the oscillation time is between several ms and tens of ms. In ceramic oscillators, the oscillation time is between hundreds of μs and several ms. An External clock of oscillation time is 0 ms.

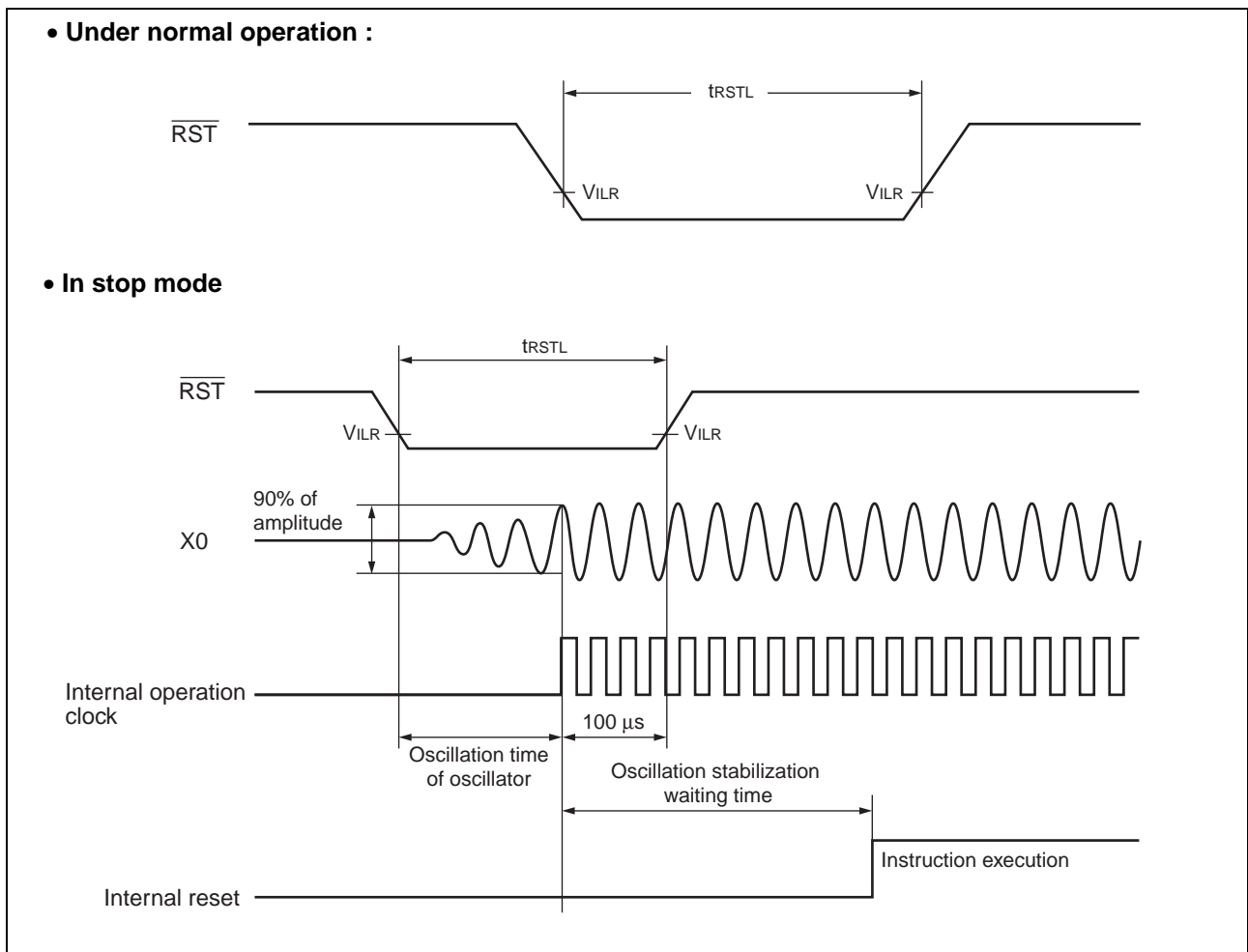

(3) Power-on Reset

Parameter	Symbol	Pin name	Condition	Value		Unit	Remarks
				Min	Max		
Power on rise time	t_{R}	V_{CC}	—	0.05	30	ms	
Power off time	t_{OFF}	V_{CC}	—	1	—	ms	Due to repetitive operation

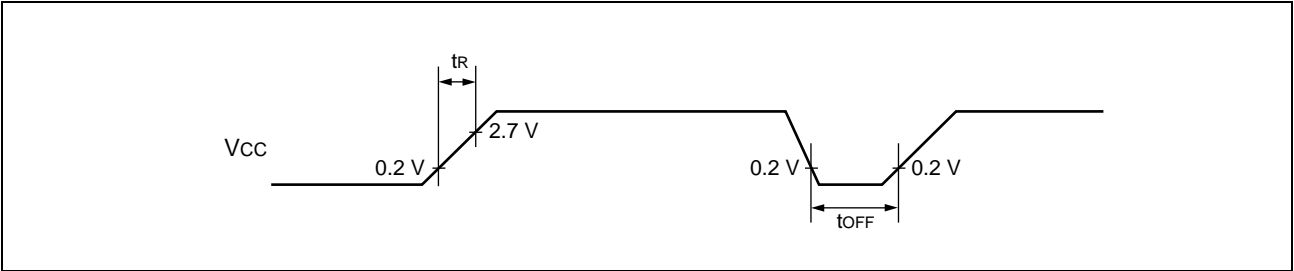

Note : If you change the power supply voltage too rapidly, a power-on reset may occur. We recommend that you start up smoothly by restraining voltages when changing the power supply voltage during operation, as shown in the figure below. Perform while not using the PLL clock. However, if voltage drops are within 1 V/s, you can operate while using the PLL clock.

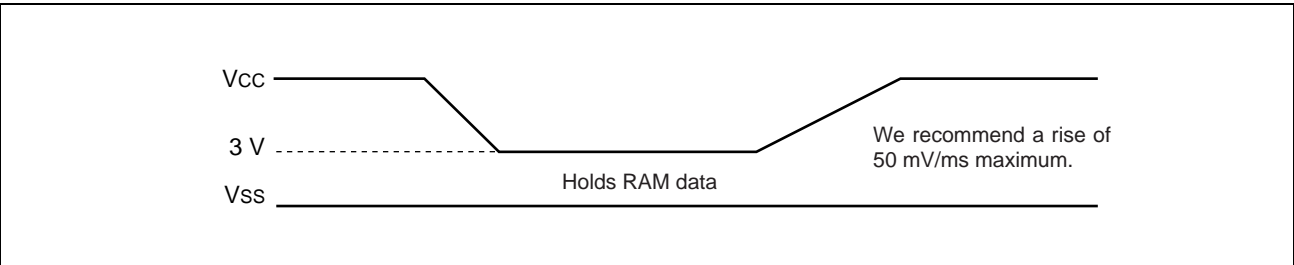

MB90910 Series

(4) UART

ESCR : SCES = 0, ECCR : SCDE = 0

Parameter	Symbol	Condition	Value		Unit
			Min	Max	
Serial clock cycle time	t_{SCYC}	Internal shift clock operation $C_L = 80\text{pF} + 1\text{TTL}$.	$5 t_{cp}^*$	—	ns
SCK ↓ → SOT delay time	t_{SLOVI}		- 50	+ 50	ns
SIN → SCK ↑ setup time	t_{IVSHI}		$t_{cp} + 80$	—	ns
SCK ↑ → SIN hold time	t_{SHIXI}		0	—	ns
Serial clock "L" pulse width	t_{LSH}	External shift clock operation $C_L = 80\text{pF} + 1\text{TTL}$.	$3 t_{cp} - t_R$	—	ns
Serial clock "H" pulse width	t_{HSL}		$t_{cp} + 10$	—	ns
SCK ↓ → SOT delay time	t_{SLOVE}		—	$2 t_{cp} + 60$	ns
SIN → SCK ↑ setup time	t_{IVSHE}		30	—	ns
SCK ↑ → SIN hold time	t_{SHIXE}		$t_{cp} + 30$	—	ns
SCK fall time	t_F		—	10	ns
SCK rise time	t_R		—	10	ns

*: The t_{cp} indicates machine clock

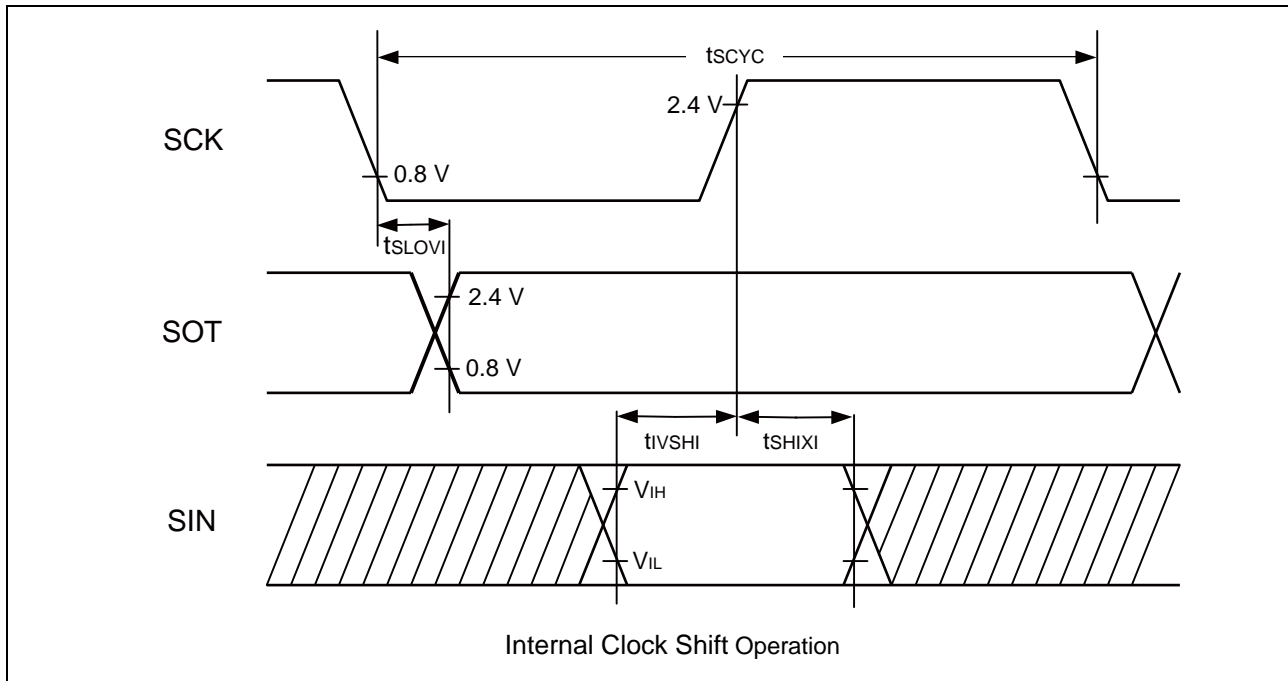

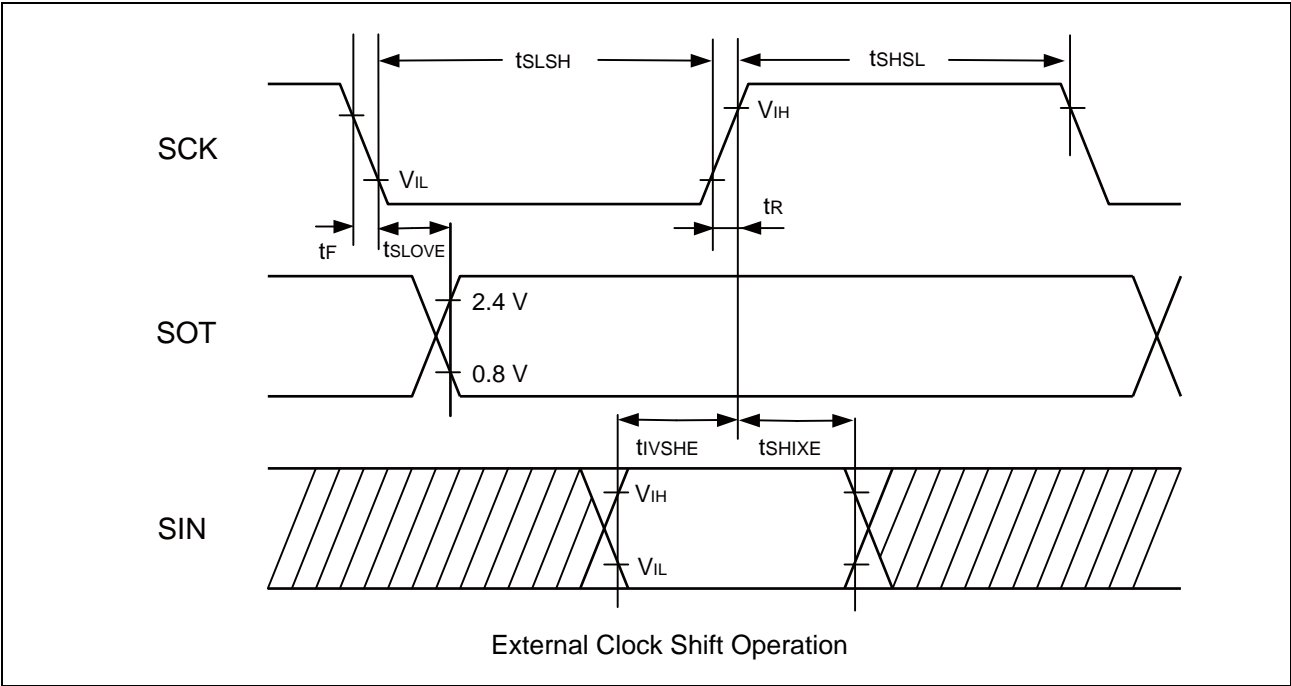

MB90910 Series

ESCR : SCES = 1, ECCR : SCDE = 0

Parameter	Symbol	Condition	Value		Unit
			Min	Max	
Serial clock cycle time	t_{SCYC}	Internal shift clock operation $C_L = 80pF + 1TTL.$	5 t_{cp}^*	—	ns
SCK \uparrow \rightarrow SOT delay time	t_{SHOVI}		- 50	+ 50	ns
SIN \rightarrow SCK \downarrow setup time	t_{IVSLI}		$t_{cp} + 80$	—	ns
SCK \downarrow \rightarrow SIN hold time	t_{SLIXI}		0	—	ns
Serial clock "H" pulse width	t_{SHSL}	External shift clock operation $C_L = 80pF + 1TTL.$	$3 t_{cp} - t_R$	—	ns
Serial clock "L" pulse width	t_{SLSH}		$t_{cp} + 10$	—	ns
SCK \uparrow \rightarrow SOT delay time	t_{SHOVE}		—	$2 t_{cp} + 60$	ns
SIN \rightarrow SCK \downarrow setup time	t_{IVSLE}		30	—	ns
SCK \downarrow \rightarrow SIN hold time	t_{SLIXE}		$t_{cp} + 30$	—	ns
SCK fall time	t_F		—	10	ns
SCK rise time	t_R		—	10	ns

*: The t_{cp} indicates machine clock

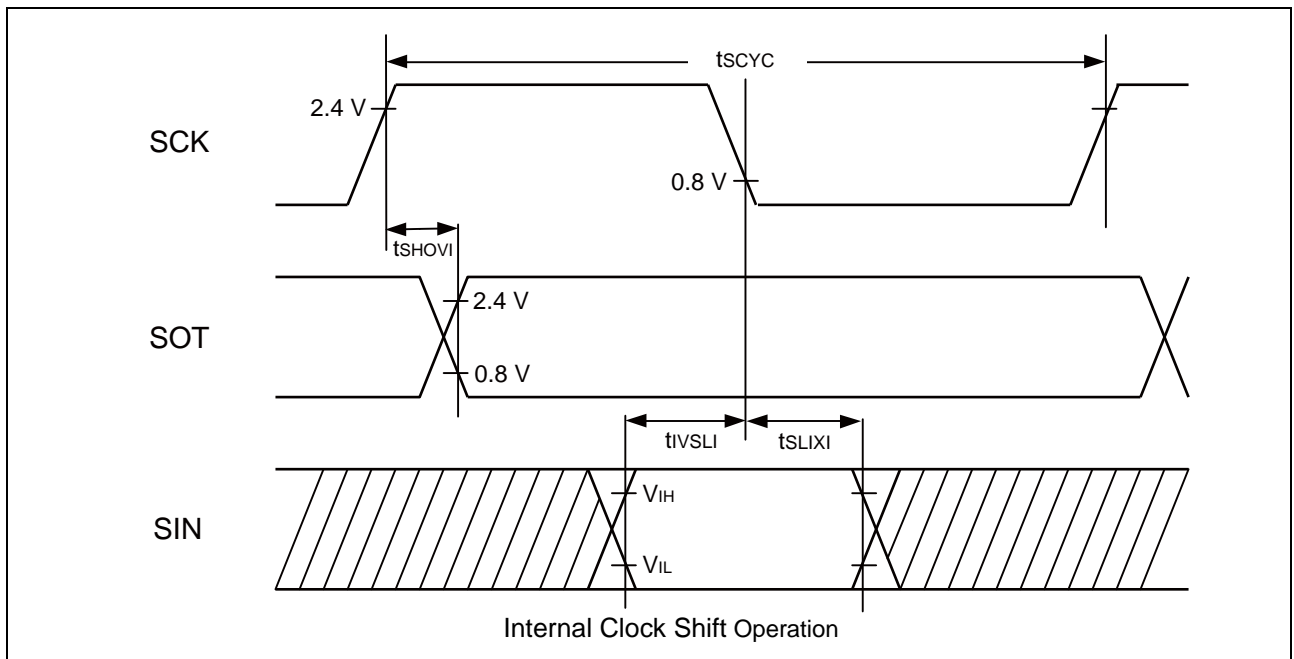

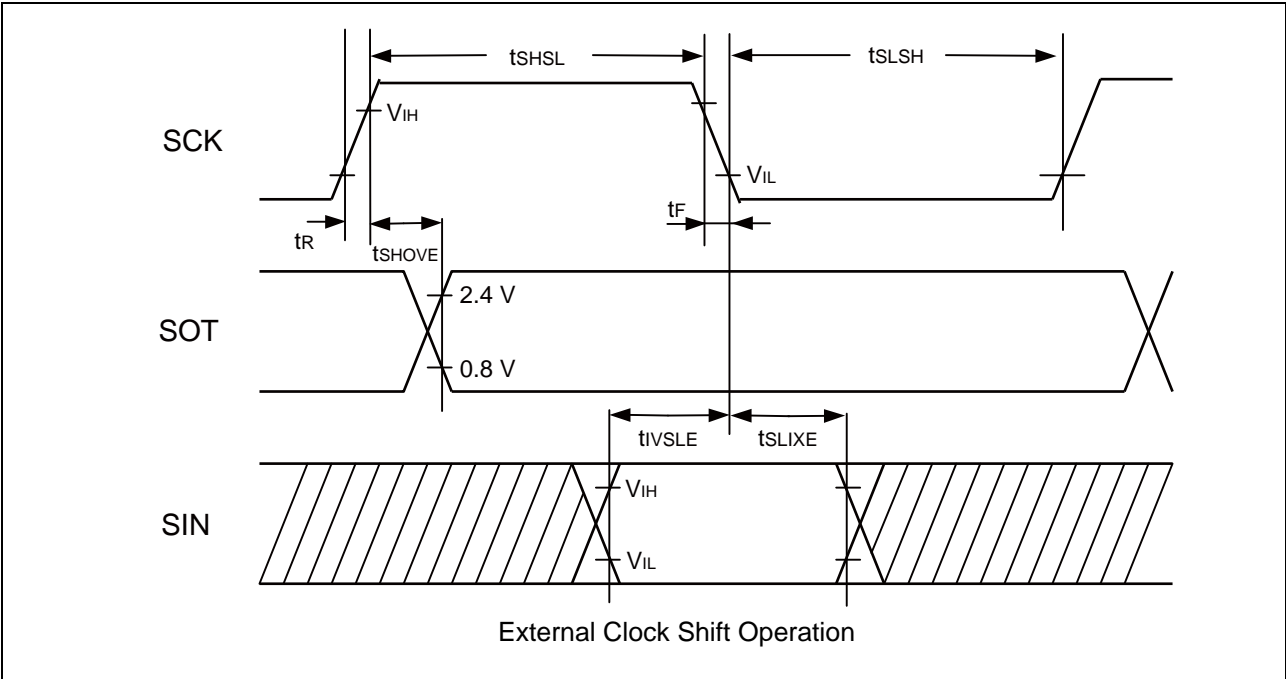

MB90910 Series

ESCR : SCES = 0, ECCR : SCDE = 1

Parameter	Symbol	Condition	Value		Unit
			Min	Max	
Serial clock cycle time	t_{SCYC}	Internal shift clock operation $C_L = 80pF + 1TTL.$	5 t_{cp}^*	—	ns
SCK \uparrow \rightarrow SOT delay time	t_{SHOVI}		- 50	+ 50	ns
SIN \rightarrow SCK \downarrow setup time	t_{IVSLI}		$t_{cp} + 80$	—	ns
SCK \downarrow \rightarrow SIN hold time	t_{SLIXI}		0	—	ns
SOT \rightarrow SCK \downarrow delay time	t_{SOVLI}		3 $t_{cp} - 70$	—	ns

*: The t_{cp} indicates machine clock

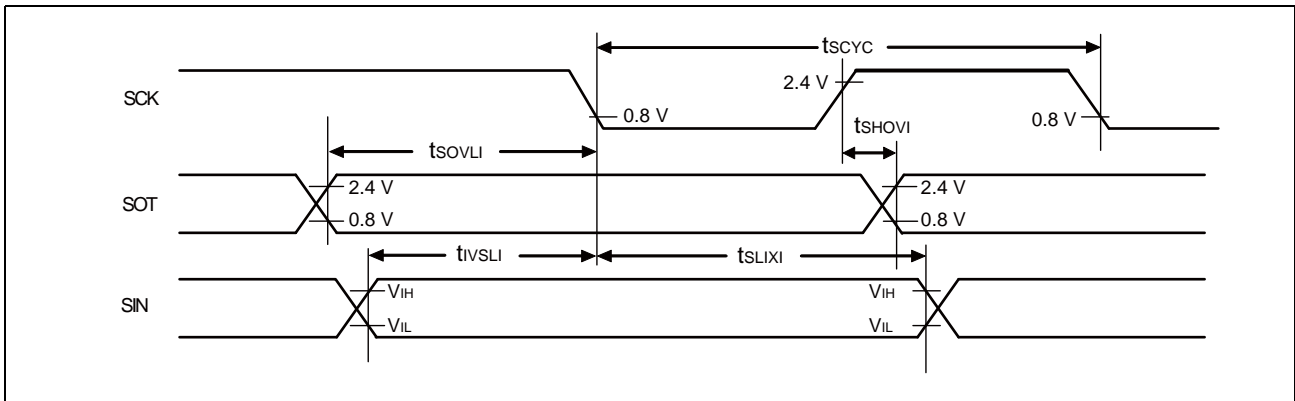

ESCR : SCES = 1, ECCR : SCDE = 1

Parameter	Symbol	Condition	Value		Unit
			Min	Max	
Serial clock cycle time	t_{SCYC}	Internal clock operation $C_L = 80pF + 1TTL.$	$5 t_{cp}^*$	—	ns
SCK ↓ → SOT delay time	t_{SLOVI}		- 50	+ 50	ns
SIN → SCK ↑ setup time	t_{IVSHI}		$t_{cp} + 80$	—	ns
SCK ↑ → SIN hold time	t_{SHIXI}		0	—	ns
SOT → SCK ↑ delay time	t_{SOVHI}		$3 t_{cp} - 70$	—	ns

*: The t_{cp} indicates machine clock

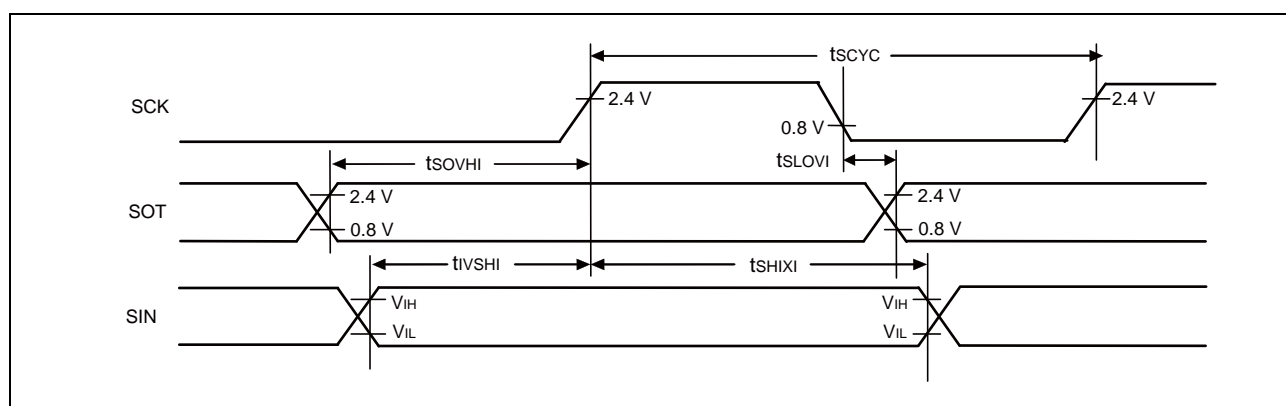

(5) Trigger Input Timing

Parameter	Symbol	Pin name	Condition	Value		Unit
				Min	Max	
Input pulse width	t_{TRGH} t_{TRGL}	INT8, INT9R INT10, INT11 INT12R, INT13 INT14R, INT15R ADTG	—	$5 t_{cp}$	—	ns

Note : t_{cp} is internal operating clock cycle time (machine clock) . Refer to “ (1) Clock Timing”.

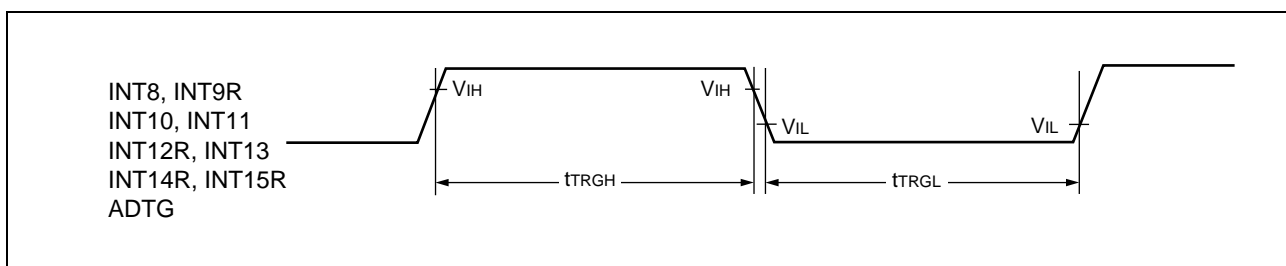

MB90910 Series

(6) Timer Related Resource Input Timing

Parameter	Symbol	Pin name	Condition	Value		Unit
				Min	Max	
Input pulse width	t_{TIWH}	TIN2, TIN3 IN0 to IN3	—	4 t_{CP}	—	ns
	t_{TIWL}					

Note : t_{CP} is internal operating clock cycle time (machine clock) . Refer to “ (1) Clock Timing”.

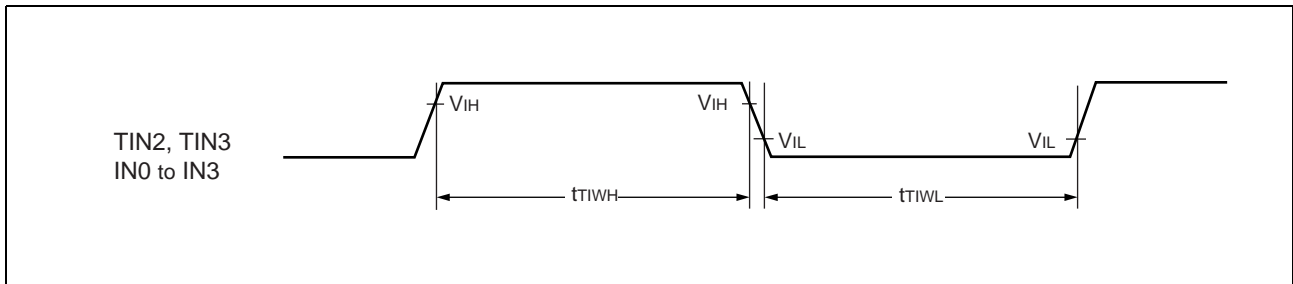

(7) Timer Related Resource Output Timing

Parameter	Symbol	Pin name	Condition	Value		Unit
				Min	Max	
CLK \uparrow \rightarrow T_{OUT} change time	t_{TO}	TOT2, TOT3 PPGA to PPGF	—	30	—	ns

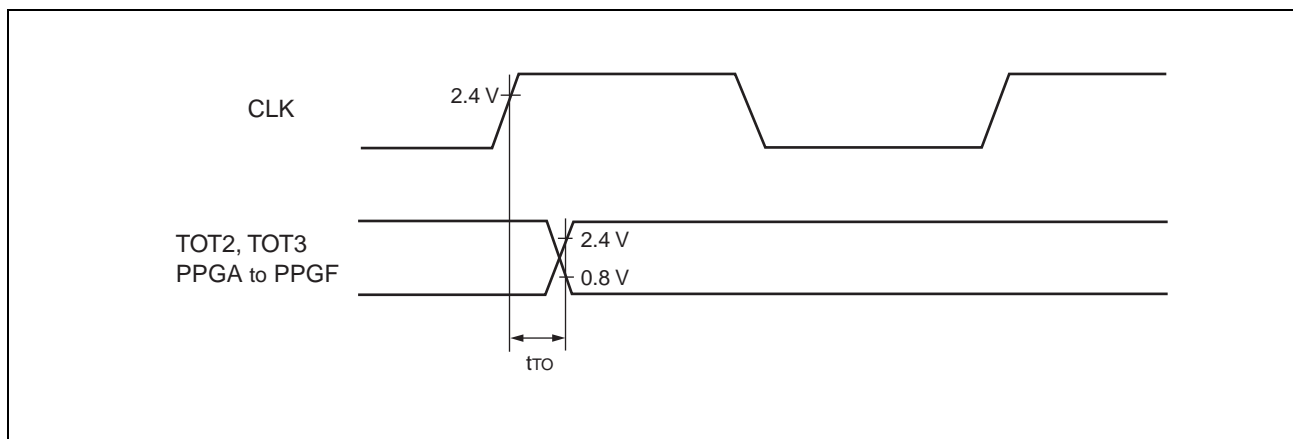

(8) CAN PLL cycle jitter

Parameter	Symbol	Pin name	Condition	Value			Unit	Remarks
				Min	Typ	Max		
CAN PLL cycle jitter (When locked)	t_{PJ}	—	—	- 10	—	+ 10	ns	$F_{CP} =$ 16 MHz (4 MHz multiplied by 4) 24 MHz (4 MHz multiplied by 6) 32 MHz (4 MHz multiplied by 8)

• CAN PLL cycle jitter

Deviation time from the ideal clock is assured per cycle out of 20, 000 cycles.

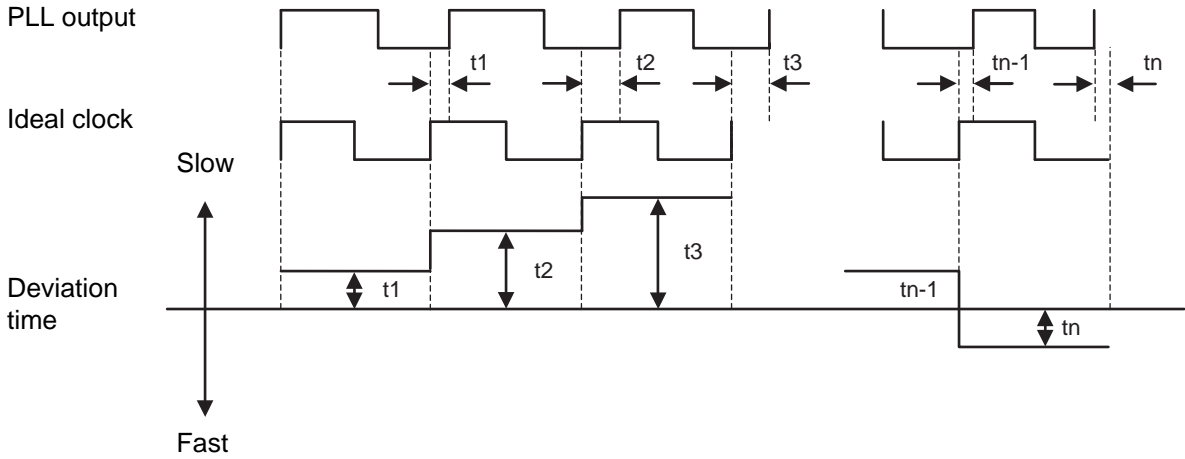

MB90910 Series

5. A/D Converter

($3.0\text{ V} \leq \text{AVR} = \text{AV}_{\text{SS}}$)

Parameter	Symbol	Pin name	Value			Unit	Remarks
			Min	Typ	Max		
Resolution	—	—	—	—	10	bit	
Total error	—	—	—	—	± 3.0	LSB	
Nonlinearity error	—	—	—	—	± 2.5	LSB	
Differential nonlinearity error	—	—	—	—	± 1.9	LSB	
Zero reading voltage	V_{OT}	AN0 to AN15	$\text{AV}_{\text{SS}} - 1.5\text{LSB}$	$\text{AV}_{\text{SS}} + 0.5\text{LSB}$	$\text{AV}_{\text{SS}} + 2.5\text{LSB}$	V	
Full scale reading voltage	V_{FST}	AN0 to AN15	$\text{AVR} - 3.5\text{LSB}$	$\text{AVR} - 1.5\text{LSB}$	$\text{AVR} + 0.5\text{LSB}$	V	
Compare time	—	—	0.66	—	16500	μs	$4.5\text{ V} \leq \text{AV}_{\text{CC}} \leq 5.5\text{ V}$
			2.2				$3.0\text{ V} \leq \text{AV}_{\text{CC}} < 4.5\text{ V}$
Sampling time	—	—	0.4	—	∞	μs	$4.5\text{ V} \leq \text{AV}_{\text{CC}} \leq 5.5\text{ V}$
			1.0				$3.0\text{ V} \leq \text{AV}_{\text{CC}} < 4.5\text{ V}$
Analog port input current	I_{AIN}	AN0 to AN15	- 3	—	+ 3	μA	
Analog input voltage range	V_{AIN}	AN0 to AN15	AV_{SS}	—	AVR	V	
Reference voltage range	—	AVR	$\text{AV}_{\text{SS}} + 2.7$	—	AV_{CC}	V	
Power supply current	I_{A}	AV_{CC}	—	3.5	7.5	mA	
	I_{AH}	AV_{CC}	—	—	5	μA	*
Reference voltage supply current	I_{R}	AVR	—	600	900	μA	
	I_{RH}	AVR	—	—	5	μA	*
Offset between input channels	—	AN0 to AN15	—	—	4	LSB	

* : If A/D converter is not operating, a current when CPU is stopped is applicable ($V_{\text{CC}} = \text{AV}_{\text{CC}} = \text{AVR} = 5.0\text{ V}$) .

- About the external impedance of analog input and its sampling time

A/D converter with sample and hold circuit. If the external impedance is too high to keep sufficient sampling time, the analog voltage changed to the internal sample and hold capacitor is insufficient, adversely affecting A/D conversion precision. Therefore, to satisfy the A/D conversion precision standard, consider the relationship between the external impedance and minimum sampling time and either adjust the resistor value and operating frequency or decrease the external impedance so that the sampling time is longer than the minimum value. And, if the sampling time cannot be sufficient, connect a capacitor of about 0.1 μF to the analog input pin.

- Analog input equivalent circuit model

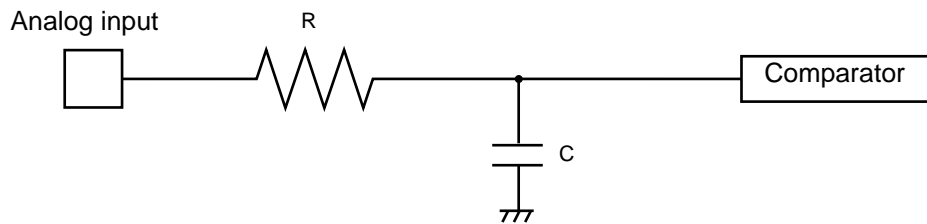

MB90V950AMAS $4.5\text{ V} \leq AV_{CC} \leq 5.5\text{ V}$: $R \cong 2.52\text{ k}\Omega$, $C \cong 10.7\text{ pF}$
 $4.0\text{ V} \leq AV_{CC} < 4.5\text{ V}$: $R \cong 13.6\text{ k}\Omega$, $C \cong 10.7\text{ pF}$

Note : The values are reference values.

MB90F912BS $4.5\text{ V} \leq AV_{CC} \leq 5.5\text{ V}$: $R \cong 4.1\text{ k}\Omega$, $C \cong 8.5\text{ pF}$
 MB90911AS $4.0\text{ V} \leq AV_{CC} < 4.5\text{ V}$: $R \cong 10.33\text{ k}\Omega$, $C \cong 8.5\text{ pF}$

6. Definition of A/D Converter Terms

- Resolution : Analog variation that is recognized by an A/D converter.
- Non linearity error : Deviation between a line across zero-transition line ("00 0000 0000_B" ← → "00 0000 0001_B") and full-scale transition line ("11 1111 1110_B" ← → "11 1111 1111_B") and actual conversion characteristics.
- Differential linearity error : Deviation of input voltage, which is required for changing output code by 1 LSB, from an ideal value.
- Total error : Difference between an actual value and an theoretical value. A total error includes zero transition error, full-scale transition error, and linear error.

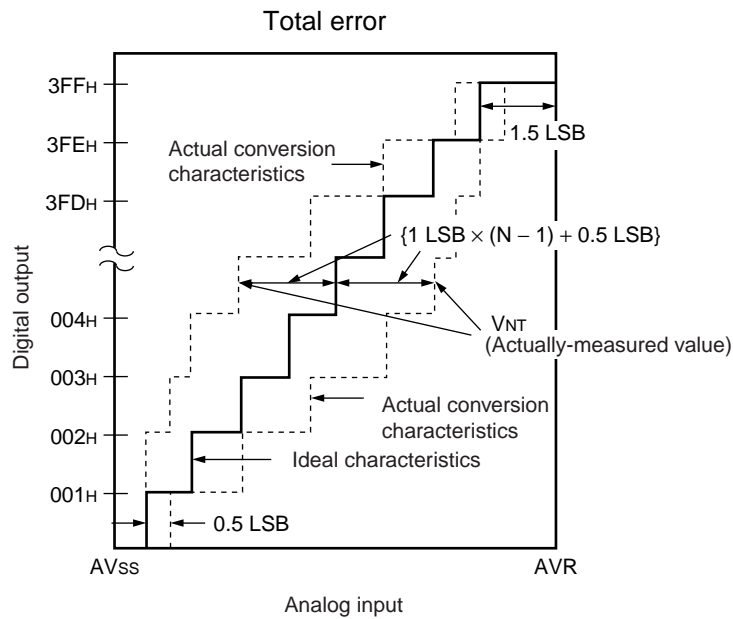

$$\text{Total error of digital output "N"} = \frac{V_{NT} - \{1 \text{ LSB} \times (N - 1) + 0.5 \text{ LSB}\}}{1 \text{ LSB}} \text{ [LSB]}$$

$$1 \text{ LSB (Ideal value)} = \frac{AVR - AV_{SS}}{1024} \text{ [V]}$$

N : A/D converter digital output value

V_{OT} (Ideal value) = $AV_{SS} + 0.5 \text{ LSB}$ [V]

V_{FST} (Ideal value) = $AVR - 1.5 \text{ LSB}$ [V]

V_{NT} : A voltage at which digital output transits from $(N - 1)_H$ to N_H .

(Continued)

(Continued)

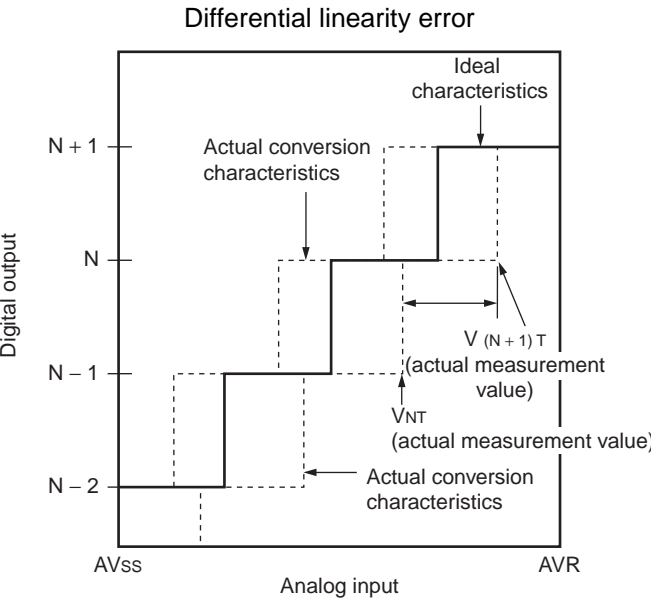
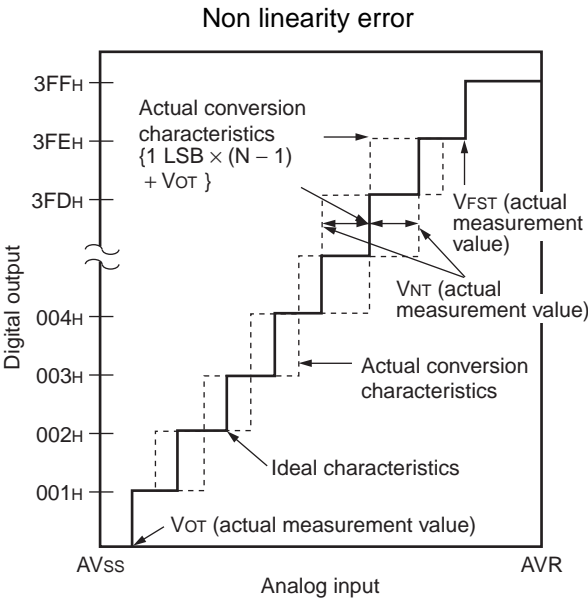

$$\text{Non linearity error of digital output } N = \frac{V_{NT} - \{1 \text{ LSB} \times (N - 1) + V_{OT}\}}{1 \text{ LSB}} \text{ [LSB]}$$

$$\text{Differential linearity error of digital output } N = \frac{V_{(N+1)T} - V_{NT}}{1 \text{ LSB}} - 1 \text{ LSB [LSB]}$$

$$1 \text{ LSB} = \frac{V_{FST} - V_{OT}}{1022} \text{ [V]}$$

- N : A/D converter digital output value
- V_{OT} : Voltage at which digital output transits from "000H" to "001H."
- V_{FST} : Voltage at which digital output transits from "3FEH" to "3FFH."

MB90910 Series

- The relationship between external impedance and minimum sampling time

- At $4.5\text{ V} \leq AV_{CC} \leq 5.5\text{ V}$

(External impedance = 0 k Ω to 100 k Ω)

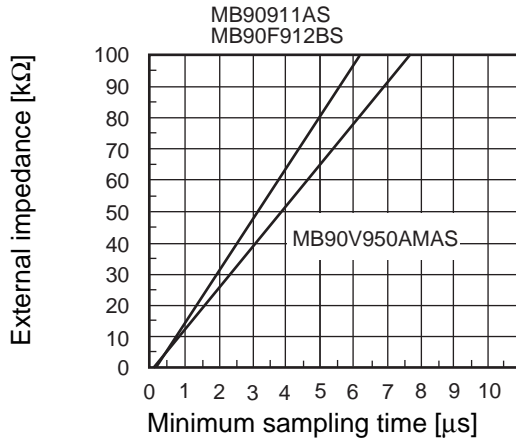

(External impedance = 0 k Ω to 20 k Ω)

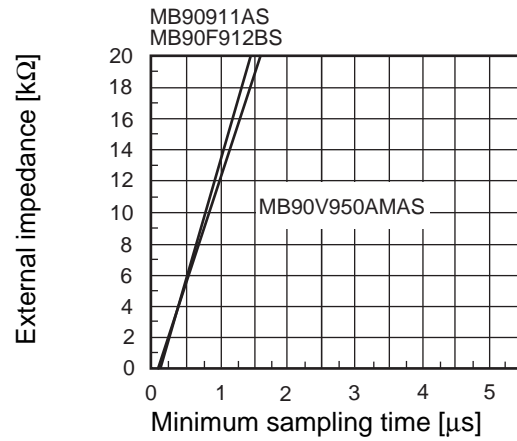

	Minimum sampling time [μs] ($4.5\text{ V} \leq AV_{CC} \leq 5.5\text{ V}$)		
External impedance [$\text{k}\Omega$]	5	10	50
MB90911AS/MB90F912BS	0.54	0.84	3.22
MB90V950AMAS	0.56	0.94	3.93

- At $3.0\text{ V} \leq AV_{CC} < 4.5\text{ V}$

(External impedance = 0 k Ω to 100 k Ω)

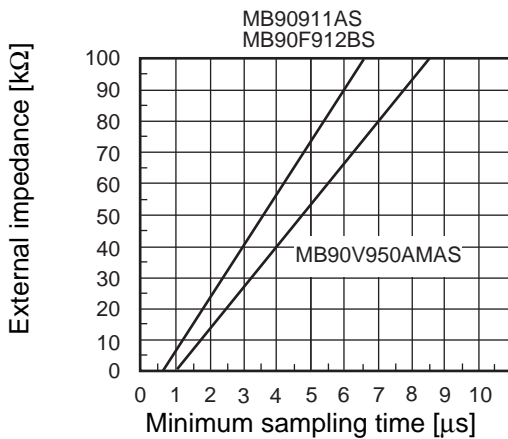

(External impedance = 0 k Ω to 20 k Ω)

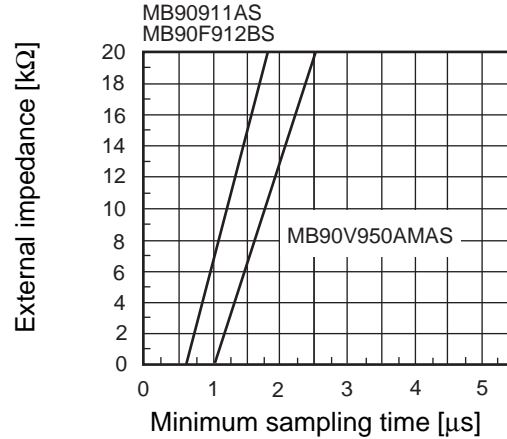

	Minimum sampling time [μs] ($3.0\text{ V} \leq AV_{CC} < 4.5\text{ V}$)		
External impedance [$\text{k}\Omega$]	5	10	50
MB90911AS/MB90F912BS	0.91	1.21	3.59
MB90V950AMAS	1.39	1.77	4.76

- About errors

As $|AVR - AV_{SS}|$ becomes smaller, values of relative errors grow larger.

7. Flash Memory Program/Erase Characteristics

Parameter	Conditions	Value			Unit	Remarks
		Min	Typ	Max		
Sector erase time	$T_A = +25\text{ }^\circ\text{C}$ $V_{CC} = 5.0\text{ V}$	—	0.9	3.6	s	Excludes programming prior to erasure
Chip erase time		—	5.4	21.6	s	
Byte (8-bit width) programming time		—	15	240	μs	Except for the overhead time of the system level
Word (16-bit width) programming time		—	23	370	μs	
Program/Erase cycle	$T_A > +85\text{ }^\circ\text{C}$	10000	—	—	cycle	
	$T_A \leq +85\text{ }^\circ\text{C}$	100000	—	—	cycle	
Flash memory data retention time	Average $T_A = +85\text{ }^\circ\text{C}$	20	—	—	year	*

* : Corresponding value comes from the technology reliability evaluation result (using Arrhenius equation to translate high temperature measurements into normalized value at +85 °C) .

MB90910 Series

■ ORDERING INFORMATION

Part number	Package	Remarks
MB90F912BSPMC	48-pin plastic LQFP (FPT-48P-M26)	
MB90911ASPMC		
MB90V950AMASCR-ES	299-pin ceramic PGA (PGA-299C-A01)	For evaluation

■ PACKAGE DIMENSION

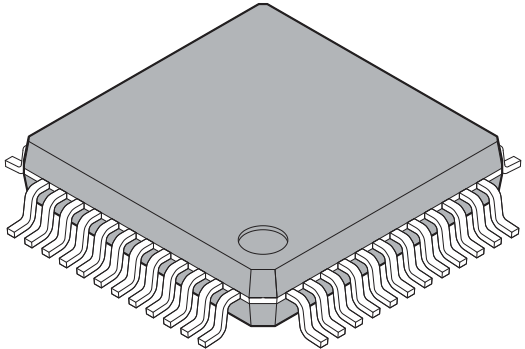
<p style="text-align: center;">48-pin plastic LQFP</p>  <p style="text-align: center;">(FPT-48P-M26)</p>	Lead pitch	0.50 mm
	Package width × package length	7 × 7 mm
	Lead shape	Gullwing
	Sealing method	Plastic mold
	Mounting height	1.70 mm MAX
	Weight	0.17 g
	Code (Reference)	P-LFQFP48-7×7-0.50

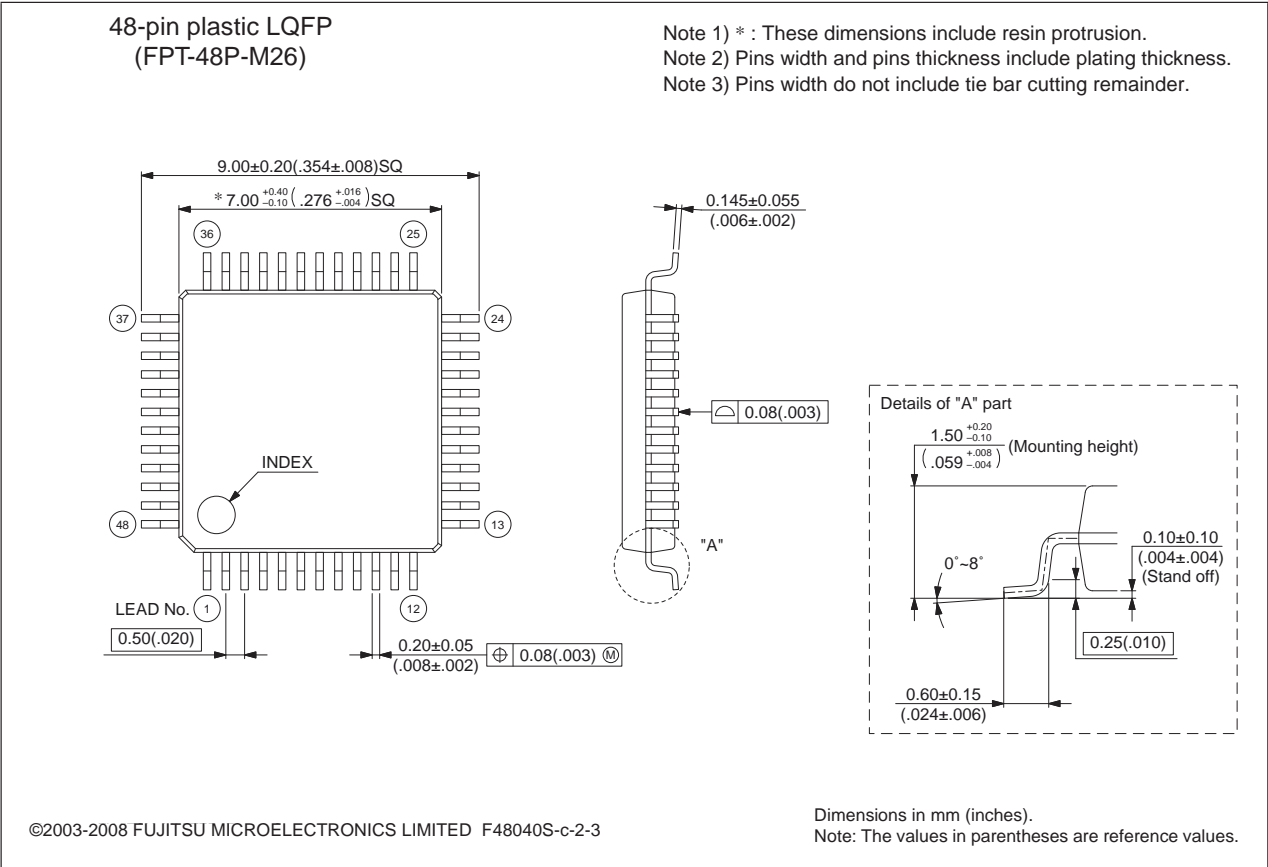

Please confirm the latest Package dimension by following URL.
<http://edevice.fujitsu.com/package/en-search/>

MB90910 Series

■ MAIN CHANGES IN THIS EDITION

Page	Section	Change Results
—	—	Changed the part number. MB90F912AS → MB90F912BS MB90V950MAS → MB90V950AMAS
4	■ PRODUCT LINEUP MB90V950AMAS	Corrected the adapter board. MB2147-20 Rev.04C → MB2147-20 Rev.04C or later
8	■ PIN DESCRIPTION Pin No.18,Pin No.19, Pin No.33 to Pin No.35,Pin No.36	Added the function as follows for pins P56, P57, P23 to P21, P20. (Different I/O circuit type from MB90V950AMAS).
10	■ I/O CIRCUIT TYPES TypeC,TypeD	Added to the “Evaluation product” on remarks.
12	TypeK	Corrected the circuit. CMOS input → CMOS hysteresis input
13	TypeL	
14	■ HANDLING DEVICES	Added the item as follows. 3.Using external clock
17	■ BLOCK DIAGRAMS MB90V950AMAS	Corrected for the prescaler. 5 channels → 7 channels
40	■ ELECTRICAL CHARACTERISTICS 3.DC Characteristics Input “H” voltage	Corrected the pin V_{IHS} . “—” → P50, P82, P85 Corrected the pin V_{IHR} . “—” → \overline{RST} Corrected the pin V_{IHM} . “—” → MD0 to MD2
	Input “L” voltage	Corrected the pin V_{ILS} . “—” → P50,P82,P85 Corrected the pin V_{ILR} . “—” → \overline{RST} Corrected the pin V_{ILM} . “—” → MD0 to MD2
	Output “H” voltage	Added to remarks of V_{OHL} . MASK ROM products and Evaluation products only
	Output “L” voltage	Added to remarks of V_{OL} . MASK ROM products and Evaluation products only
	Input leak current	Corrected the value. Min : - 1 → - 3 Max : + 1 → + 3
	Pull-down resistance	Corrected the remark. MASK ROM products only → MASK ROM products and Evaluation products only
44	4.AC Characteristics (1)Reset Standby Input	Changed the unit for “Oscillation time of oscillator*+ 100 μ s” . ns → μ s
53	(8) CAN PLL cycle jitter	Added the item.

(Continued)

(Continued)

Page	Section	Change Results
54	5.A/D Converter	Corrected the remark of "Compare time". 4.5 V ≤ AV _{CC} → 4.5 V ≤ AV _{CC} ≤ 5.5 V 3.0 V ≤ AV _{CC} → 3.0 V ≤ AV _{CC} < 4.5 V
		Corrected the remark of "Sampling time". 4.5 V ≤ AV _{CC} → 4.5 V ≤ AV _{CC} ≤ 5.5 V 3.0 V ≤ AV _{CC} → 3.0 V ≤ AV _{CC} < 4.5 V
		Changed the value of "Analog port input current". Min : - 0.3 → - 3 Max : + 0.3 → + 3
60	■ ORDERING INFORMATION	Changed the part number. MB90F912ASPMC → MB90F912BSPMC MB90V950MASCR-ES → MB90V950AMASCR-ES

The vertical lines marked in the left side of the page show the changes.

MB90910 Series

FUJITSU MICROELECTRONICS LIMITED

Shinjuku Dai-Ichi Seimei Bldg., 7-1, Nishishinjuku 2-chome,
Shinjuku-ku, Tokyo 163-0722, Japan
Tel: +81-3-5322-3329
<http://jp.fujitsu.com/fml/en/>

For further information please contact:

North and South America

FUJITSU MICROELECTRONICS AMERICA, INC.
1250 E. Arques Avenue, M/S 333
Sunnyvale, CA 94085-5401, U.S.A.
Tel: +1-408-737-5600 Fax: +1-408-737-5999
<http://www.fma.fujitsu.com/>

Asia Pacific

FUJITSU MICROELECTRONICS ASIA PTE. LTD.
151 Lorong Chuan,
#05-08 New Tech Park 556741 Singapore
Tel : +65-6281-0770 Fax : +65-6281-0220
<http://www.fmal.fujitsu.com/>

Europe

FUJITSU MICROELECTRONICS EUROPE GmbH
Pittlerstrasse 47, 63225 Langen, Germany
Tel: +49-6103-690-0 Fax: +49-6103-690-122
<http://emea.fujitsu.com/microelectronics/>

FUJITSU MICROELECTRONICS SHANGHAI CO., LTD.

Rm. 3102, Bund Center, No.222 Yan An Road (E),
Shanghai 200002, China
Tel : +86-21-6146-3688 Fax : +86-21-6335-1605
<http://cn.fujitsu.com/fmc/>

Korea

FUJITSU MICROELECTRONICS KOREA LTD.
206 Kosmo Tower Building, 1002 Daechi-Dong,
Gangnam-Gu, Seoul 135-280, Republic of Korea
Tel: +82-2-3484-7100 Fax: +82-2-3484-7111
<http://kr.fujitsu.com/fmk/>

FUJITSU MICROELECTRONICS PACIFIC ASIA LTD.

10/F., World Commerce Centre, 11 Canton Road,
Tsimshatsui, Kowloon, Hong Kong
Tel : +852-2377-0226 Fax : +852-2376-3269
<http://cn.fujitsu.com/fmc/en/>

Specifications are subject to change without notice. For further information please contact each office.

All Rights Reserved.

The contents of this document are subject to change without notice.

Customers are advised to consult with sales representatives before ordering.

The information, such as descriptions of function and application circuit examples, in this document are presented solely for the purpose of reference to show examples of operations and uses of FUJITSU MICROELECTRONICS device; FUJITSU MICROELECTRONICS does not warrant proper operation of the device with respect to use based on such information. When you develop equipment incorporating the device based on such information, you must assume any responsibility arising out of such use of the information.

FUJITSU MICROELECTRONICS assumes no liability for any damages whatsoever arising out of the use of the information.

Any information in this document, including descriptions of function and schematic diagrams, shall not be construed as license of the use or exercise of any intellectual property right, such as patent right or copyright, or any other right of FUJITSU MICROELECTRONICS or any third party or does FUJITSU MICROELECTRONICS warrant non-infringement of any third-party's intellectual property right or other right by using such information. FUJITSU MICROELECTRONICS assumes no liability for any infringement of the intellectual property rights or other rights of third parties which would result from the use of information contained herein.

The products described in this document are designed, developed and manufactured as contemplated for general use, including without limitation, ordinary industrial use, general office use, personal use, and household use, but are not designed, developed and manufactured as contemplated (1) for use accompanying fatal risks or dangers that, unless extremely high safety is secured, could have a serious effect to the public, and could lead directly to death, personal injury, severe physical damage or other loss (i.e., nuclear reaction control in nuclear facility, aircraft flight control, air traffic control, mass transport control, medical life support system, missile launch control in weapon system), or (2) for use requiring extremely high reliability (i.e., submersible repeater and artificial satellite).

Please note that FUJITSU MICROELECTRONICS will not be liable against you and/or any third party for any claims or damages arising in connection with above-mentioned uses of the products.

Any semiconductor devices have an inherent chance of failure. You must protect against injury, damage or loss from such failures by incorporating safety design measures into your facility and equipment such as redundancy, fire protection, and prevention of over-current levels and other abnormal operating conditions.

Exportation/release of any products described in this document may require necessary procedures in accordance with the regulations of the Foreign Exchange and Foreign Trade Control Law of Japan and/or US export control laws.

The company names and brand names herein are the trademarks or registered trademarks of their respective owners.

Edited: Sales Promotion Department