

16-bit Microcontroller

CMOS

F²MC-16LX MB90800 Series

**MB90803/803S/F803/F803S/F804-101/
MB90F804-201/F809/F809S/V800**

■ DESCRIPTION

The MB90800 series is a general-purpose 16-bit microcontroller that has been developed for high-speed real-time processing required for industrial and office automation equipment and process control, etc. The LCD controller of 48 segment four common is built into.

Instruction set has taken over the same AT architecture as in the F²MC-8L and F²MC-16L, and is further enhanced to support high level languages, extend addressing mode, enhanced divide/multiply instructions with sign and enrichment of bit processing. In addition, long word processing is now available by introducing a 32-bit accumulator.

Note: F²MC is the abbreviation of Fujitsu Flexible Microcontroller.

■ FEATURES

• Clock

- Built-in PLL clock frequency multiplication circuit
- Operating clock (PLL clock) : divided-by-2 of oscillation (at oscillation of 6.25 MHz) or
1 to 4 times the oscillation (at oscillation of 6.25 MHz to 25 MHz).
- Minimum instruction execution time of 40.0 ns (at oscillation of 6.25 MHz, four times the PLL clock, operation at V_{CC} = 3.3 V)

• The maximum memory space:16 Mbytes

- 24-bit internal addressing
- Bank addressing

(Continued)

For the information for microcontroller supports, see the following web site.

<http://edevice.fujitsu.com/micom/en-support/>

MB90800 Series

(Continued)

- **Optimized instruction set for controller applications**
 - Wide choice of data types (bit, byte, word, and long word)
 - Wide choice of addressing modes (23 types)
 - High code efficiency
 - Enhanced high-precision computing with 32-bit accumulator
 - Enhanced Multiply/Divide instructions with sign and the RETI instruction
- **Instruction system compatible with high-level language (C language) and multitask**
 - Employing system stack pointer
 - Instruction set has symmetry and barrel shift instructions
- **Program Patch Function (2 address pointer)**
- **4-byte instruction queue**
- **Interrupt function**
 - The priority level can be set to programmable.
 - Interrupt function with 32 factors
- **Data transfer function**
 - Expanded intelligent I/O service function (EI²OS): Maximum of 16 channels
- **Low Power Consumption Mode**
 - Sleep mode (a mode that halts CPU operating clock)
 - Time-base timer mode (a mode that operates oscillation clock and time-base timer)
 - Watch mode (mode in which only the subclock and watch timers operate)
 - Stop mode (a mode that stops oscillation clock and sub clock)
 - CPU blocking mode (operating CPU at each set cycle)
- **Package**
 - QFP-100 (FPT-100P-M06 : 0.65 mm lead pitch)
- **Process : CMOS technology**

MB90800 Series

■ PRODUCT LINEUP

Part number	MB90V800-101/201	MB90F804-101/201	MB90803/MB90803S	MB90F803/MB90F803S	MB90F809/MB90F809S
Type	Evaluation product	Flash memory products	Mask ROM products	Flash memory products	
System clock	On-chip PLL clock multiplication method (× 1, × 2, × 3, × 4, 1/2 when PLL stops) Minimum instruction execution time of 40.0 ns (at oscillation of 6.25 MHz, four times the PLL clock)				
Sub clock	With sub clock: 201 option Without sub clock: 101 option		With sub clock: Part number of products without "S" suffix Without sub clock: Part number of products with "S" suffix		
ROM capacity	No	256 Kbytes	128 Kbytes	128 Kbytes dual operation	192 Kbytes
RAM capacity	28 Kbytes	16 Kbytes	4 Kbytes	4 Kbytes	10 Kbytes
CPU functions	Number of basic instructions : 351 Minimum instruction execution time : 40.0 ns/6.25 MHz oscillator (When four times is used : machine clock 25 MHz, Power supply voltage : 3.3 V ± 0.3 V) Addressing type : 23 types Program Patch Function : 2 address pointers The maximum memory space : 16 Mbytes				
Ports	I/O port (CMOS) 68 ports (shared with resources), (70 ports when the subclock is not used)				
LCD controller/driver	Segment driver that can drive the LCD panel (liquid crystal display) directly, and common driver 48 SEG × 4 COM				
16-bit input/output timer	16-bit free-run timer	1 channel Overflow interrupt			
	Output compare (OCU)	2 channels Pin input factor: matching of the compare register			
	Input capture (ICU)	2 channels Rewriting a register value upon a pin input (rising edge, falling edge, or both edges)			
16-bit Reload Timer	16-bit reload timer operation (toggle output, single shot output selectable) The event count function is optional. The event count function is optional. Three channels are built in.				
16-bit PPG timer	Output pin × 2 ports Operating clock frequency : fcp, fcp/22, fcp/24, fcp/26 Two channels are built in.				
Time-base timer	1 channel				
Watchdog timer	1 channel				
Timer clock output circuit	Clock with a frequency of external input clock divided by 16/32/64/128 can be output externally.				
I ² C bus	I ² C Interface. 1 channel is built-in.				

(Continued)

MB90800 Series

(Continued)

Part number Item	MB90V800- 101/201	MB90F804- 101/201	MB90803/ MB90803S	MB90F803/ MB90F803S	MB90F809/ MB90F809S
8/10-bit A/D converter	12 channels (input multiplex) The 8-bit resolution or 10-bit resolution can be set. Conversion time : 5.9 μ s (When machine clock 16.8 MHz works).				
UART	Full-duplex double buffer Asynchronous/synchronous transmit (with start/stop bits) are supported. Two channels are built in.				
Extended I/O serial interface	Two channels are built in.				
Interrupt delay interrupt	One channel				
DTP/External interrupt	4 channels Interrupt causes : "L" \rightarrow "H" edge/"H" \rightarrow "L" edge/"L" level/"H" level selectable				
Low Power Consumption Mode	Sleep mode/Time-base timer mode/Watch mode/Stop mode/CPU intermittent mode				
Process	CMOS				
Operating voltage	2.7 V to 3.6 V				

■ PIN ASSIGNMENT

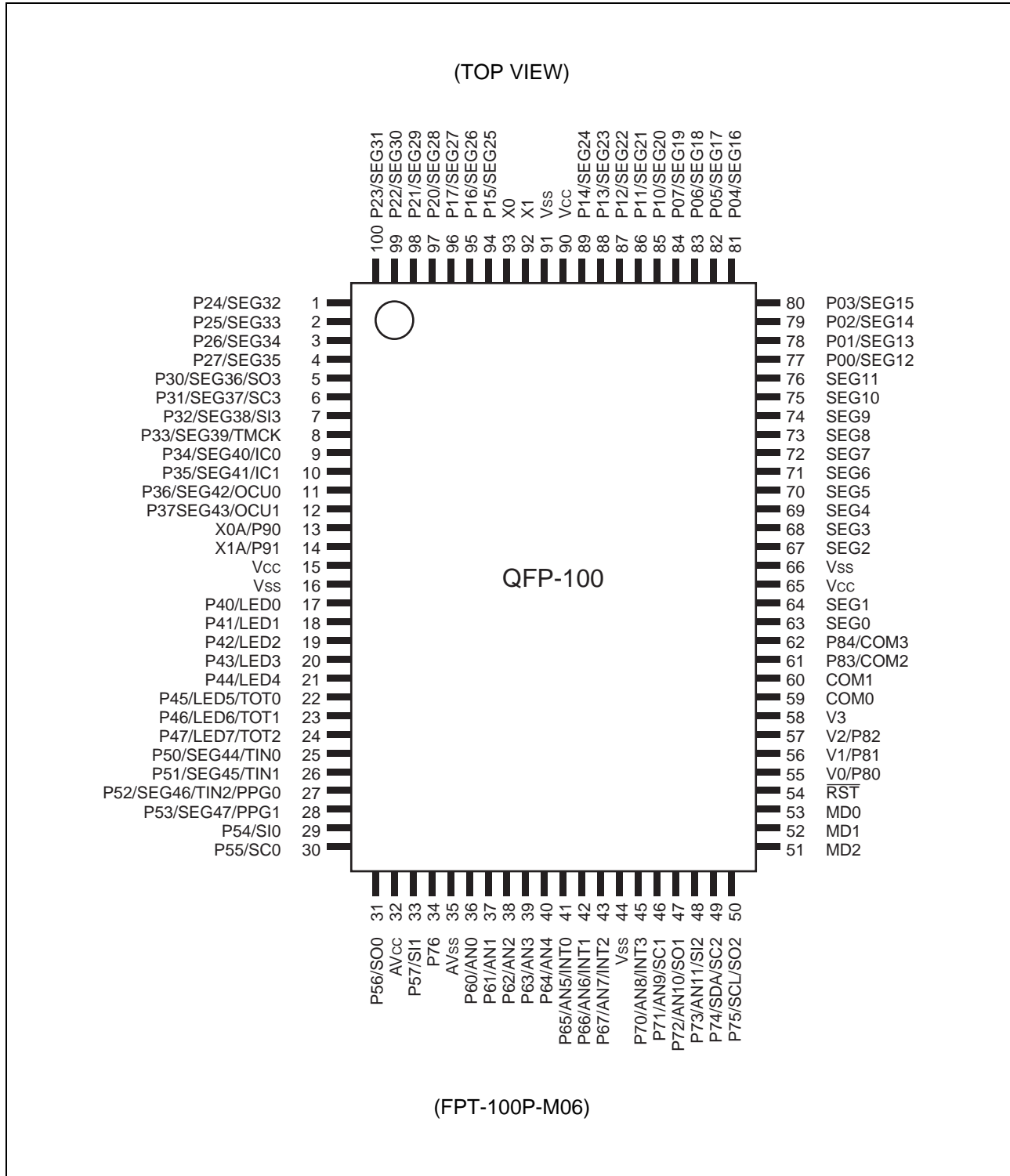

MB90800 Series

■ PIN DESCRIPTION

Pin No.	Pin Name	I/O Circuit Type*	Status/function at reset	Function
92, 93	X1, X0	A	Oscillation status	It is a terminal which connects the oscillator. When connecting an external clock, leave the x1 pin unconnected.
13, 14	X0A, X1A	B	Oscillation status	It is 32 kHz oscillation pin. (Dual-line model)
	P90, P91	G	Port input (High-Z)	General purpose input/output port. (Single-line model)
51	MD2	M	Mode Pins	Input pin for selecting operation mode. Connect directly to Vss.
52, 53	MD1, MD0	L	Mode Pins	Input pin for selecting operation mode. Connect directly to Vcc.
54	$\overline{\text{RST}}$	K	Reset input	External reset input pin.
63, 64, 67 to 76	SEG0 to SEG11	D	LCD SEG output	A segment output terminal of the LCD controller/driver.
77 to 84	SEG12 to SEG19	E	Port input (High-Z)	A segment output terminal of the LCD controller/driver.
	P00 to P07			General purpose input/output port.
85 to 89, 94 to 96	SEG20 to SEG27	E		A segment output terminal of the LCD controller/driver.
	P10 to P17			General purpose input/output port.
97 to 100, 1 to 4	SEG28 to SEG35	E		A segment output terminal of the LCD controller/driver.
	P20 to P27			General purpose input/output port.
5	SEG36	E		A segment output terminal of the LCD controller/driver.
	P30			General purpose input/output port.
	SO3			Serial data output pin of serial I/O ch.3. Valid when serial data output of serial I/O ch.3 is enabled.
6	SEG37	E		A segment output terminal of the LCD controller/driver.
	P31		General purpose input/output port.	
	SC3		Serial clock I/O pin of serial I/O ch.3. Valid when serial clock output of serial I/O ch.3 is enabled.	

(Continued)

MB90800 Series

Pin No.	Pin Name	I/O Circuit Type*	Status/function at reset	Function
7	SEG38	E	Port input (High-Z)	A segment output terminal of the LCD controller/driver.
	P32			General purpose input/output port.
	SI3			Serial data input pin of serial I/O ch.3. This pin may be used during serial I/O ch.3 in input mode, so it cannot use as other pin function.
8	SEG39	E		A segment output terminal of the LCD controller/driver.
	P33			General purpose input/output port.
	TMCK			Timer clock output pin. It is effective when permitting the power output.
9, 10	SEG40, SEG41	E		A segment output terminal of the LCD controller/driver.
	P34, P35			General purpose input/output port.
	IC0, IC1			External trigger input pin of input capture ch.0/ch.1.
11, 12	SEG42, SEG43	E		A segment output terminal of the LCD controller/driver.
	P36, P37		General purpose input/output port.	
	OCU0, OCU1		Output terminal for the output compares ch.0/ch.1.	
17 to 21	LED0 to LED4	F	It is a output terminal for LED ($I_{OL} = 15 \text{ mA}$).	
	P40 to P44		General purpose input/output port.	
22 to 24	LED5 to LED7	F	It is a output terminal for LED ($I_{OL} = 15 \text{ mA}$).	
	P45 to P47		General purpose input/output port.	
	TOT0 to TOT2		External event output pin of reload timer ch.0 to ch.2. It is effective when permitting the external event output.	
25, 26	SEG44, SEG45	E	A segment output terminal of the LCD controller/driver.	
	P50, P51		General purpose input/output port.	
	TIN0, TIN1		External clock input pin of reload timer ch.0, ch.1. It is effective when permitting the external clock input.	

(Continued)

MB90800 Series

Pin No.	Pin Name	I/O Circuit Type*	Status/function at reset	Function
27	SEG46	E	Port input (High-Z)	A segment output terminal of the LCD controller/driver.
	P52			General purpose input/output port.
	TIN2			External clock input pin of reload timer ch.2. It is effective when permitting the external clock input.
	PPG0			PPG timer (ch.0) output pin.
28	SEG47	E		A segment output terminal of the LCD controller/driver.
	P53			General purpose input/output port.
	PPG1			PPG (ch.1) timer output pin.
29	SIO	G		Serial data input pin of UART ch.0. This pin may be used during UART ch.0 in receiving mode, so it cannot use as other pin function.
	P54			General purpose input/output port.
30	SC0	G		Serial clock input/output pin of UART ch.0. It is effective when permitting the serial clock output of UART ch.0.
	P55		General purpose input/output port.	
31	SO0	G	Serial data output pin of UART ch.0. It is effective when permitting the serial clock output of UART ch.0.	
	P56		General purpose input/output port.	
33	SI1	G	Serial data input pin of UART ch.1. This pin may be used during UART ch.1 in receiving mode, so it cannot use as other pin function.	
	P57		General purpose input/output port.	
34	P76	G	General purpose input/output port.	
36 to 40	AN0 to AN4	I	Analog input pin ch.0 to ch.4 of A/D converter. Enabled when analog input setting is "enabled"(set by ADER).	
	P60 to P64		General purpose input/output port.	

(Continued)

Pin No.	Pin Name	I/O Circuit Type*	Status/function at reset	Function
41 to 43	AN5 to AN7	I	Analog input (High-Z)	Analog input pin ch.5 to ch.7 of A/D converter. Enabled when analog input setting is "enabled".
	P65 to P67			General purpose input/output port.
	INT0 to INT2			Functions as an external interrupt ch.0 to ch.2 input pin.
45	AN8	I		Analog input pin ch.8 of A/D converter. Enabled when analog input setting is "enabled".
	P70			General purpose input/output port.
	INT3			Functions as an external interrupt ch.3 input pin.
46	AN9	I		Analog input pin ch.9 of A/D converter. Enabled when analog input setting is "enabled".
	P71			General purpose input/output port.
	SC1			Serial clock input/output pin of UART ch.1. It is effective when permitting the serial clock output of UART ch.1.
47	AN10	I	Port input (High-Z)	Analog input pin ch.10 of A/D converter. Enabled when analog input setting is "enabled".
	P72			General purpose input/output port.
	SO1			Serial data output pin of serial I/O ch.1. Valid when serial data output of serial I/O ch.1 is enabled.
48	AN11	I		Analog input pin ch.11 of A/D converter. Enabled when analog input setting is "enabled".
	P73			General purpose input/output port.
	SI2			Serial data input pin of serial I/O ch.2. This pin may be used during serial I/O ch.2 in input mode, so it cannot use as other pin function.

(Continued)

MB90800 Series

(Continued)

Pin No.	Pin Name	I/O Circuit Type*	Status/function at reset	Function
49	SDA	H	Port input (High-Z)	Data input/output pin of I ² C Interface. This pin is enabled when the I ² C interface is operated. While the I ² C interface is running, the port must be set for input use.
	P74			General purpose input/output port. (N-ch open-drain, withstand voltage of 5 V.)
	SC2			Serial clock input pin of serial I/O ch.2. Valid when serial clock output of serial I/O ch.2 is enabled.
50	SCL	H		Clock input/output pin of I ² C Interface. This pin is enabled when the I ² C interface is operated. While the I ² C interface is running, the port must be set for input use.
	P75			General purpose input/output port. (N-ch open-drain, withstand voltage of 5 V.)
	SO2			Serial data output pin of serial I/O ch.2. Valid when serial data output of serial I/O ch.2 is enabled.
55 to 57	V0 to V2	J	LCD drive power supply input	LCD controller/driver. Reference power terminals of LCD controller/driver.
	P80 to P82			General purpose input/output port.
59, 60	COM0, COM1	D	LCD COM output	A common output terminal of the LCD controller/driver.
61, 62	P83, P84	E	Port input (High-Z)	General purpose input/output port.
	COM2, COM3			A common output terminal of the LCD controller/driver.
32	AV _{CC}	C	Power supply	A/D converter exclusive power supply input pin.
35	AV _{SS}	C		A/D converter-exclusive GND power supply pin.
58	V3	J		LCD controller/driver Reference power terminals of LCD controller/driver.
15, 65, 90	V _{CC}	—		These are power supply input pins.
16, 44, 66, 91	V _{SS}	—		GND power supply pin.

* : Refer to “■ I/O CIRCUIT TYPE” for details on the I/O circuit types.

■ I/O CIRCUIT TYPE

Type	Circuit	Remarks
A		Oscillation feedback resistance : 1 MΩ approx.
B		Low-rate oscillation feedback resistor, approx.10 MΩ
C		Analog power supply input protection circuit
D		LCDC output
E		<ul style="list-style-type: none"> • CMOS output • LCDC output • CMOS hysteresis input (With input interception function at standby)

(Continued)

MB90800 Series

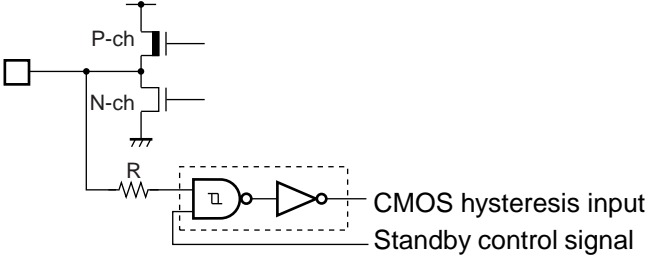
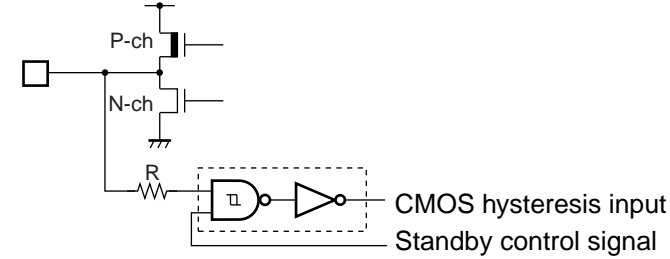
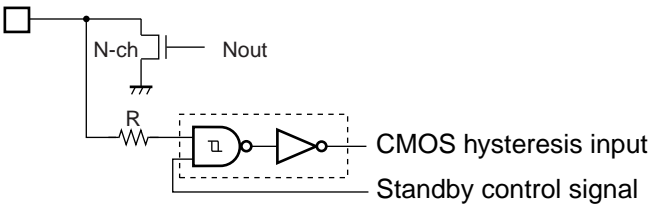
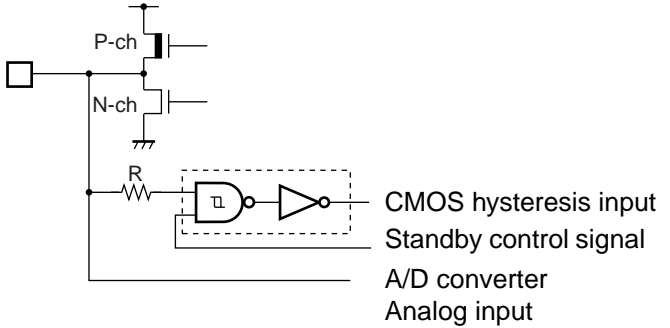
Type	Circuit	Remarks
F	 <p>CMOS hysteresis input Standby control signal</p>	<ul style="list-style-type: none"> • CMOS output (Heavy-current $I_{OL} = 15\text{ mA}$ for LED drive) • CMOS hysteresis input (With input interception function at standby)
G	 <p>CMOS hysteresis input Standby control signal</p>	<ul style="list-style-type: none"> • CMOS output • CMOS hysteresis input (With input interception function at standby) <p>Notes :</p> <ul style="list-style-type: none"> • The I/O port and internal resources share one output buffer for their outputs. • The I/O port and internal resources share one input buffer for their input.
H	 <p>CMOS hysteresis input Standby control signal</p>	<ul style="list-style-type: none"> • CMOS hysteresis input (With input interception function at standby) • N-ch open drain output
I	 <p>CMOS hysteresis input Standby control signal A/D converter Analog input</p>	<ul style="list-style-type: none"> • CMOS output • CMOS hysteresis input (With input interception function at standby) • Analog input (If the bit of analog input enable register = 1, the analog input of A/D converter is enabled.) <p>Notes :</p> <ul style="list-style-type: none"> • The I/O port and internal resources share one output buffer for their outputs. • The I/O port and internal resources share one input buffer for their inputs.

(Continued)

(Continued)

Type	Circuit	Remarks
J		<ul style="list-style-type: none"> • CMOS output • CMOS hysteresis input (With input interception function at standby) • LCD drive power supply input
K		<p>CMOS hysteresis input with pull-up resistor.</p>
L		<p>CMOS hysteresis input</p>
M		<p>CMOS hysteresis input with pull-down resistor</p>

MB90800 Series

■ HANDLING DEVICES

1. Preventing Latch-up, Turning on Power Supply

Latch-up may occur on CMOS IC under the following conditions:

- If a voltage higher than V_{CC} or lower than V_{SS} is applied to input and output pins,
- A voltage higher than the rated voltage is applied between V_{CC} pin and V_{SS} pin.
- If the AV_{CC} power supply is turned on before the V_{CC} voltage.

Ensure that you apply a voltage to the analog power supply at the same time as V_{CC} or after you turn on the digital power supply (when you perform power-off, turn off the analog power supply first or at the same time as V_{CC} and the digital power supply).

When latch-up occurs, power supply current increases rapidly and might thermally damage elements. When using CMOS IC, take great care to prevent the occurrence of latch-up.

2. Treatment of unused pins

If unused input pins are left open, they may cause abnormal operation or latch-up which may lead to permanent damage to the semiconductor. Any such pins should be pulled up or pulled down through resistance of at least 2 k Ω .

Any unused input/output pins should be left open in output status, or if found set to input status, they should be treated in the same way as input pins.

Any unused output pins should be left open.

3. Treatment of A/D converter power supply pins

Even if the A/D converter is not used, pins should be connected so that $AV_{CC} = V_{CC}$, and $AV_{SS} = V_{SS}$.

4. About the attention when the external clock is used

In using an external clock, drive pin X0 only and leave pin X1 open.

The example of using an external clock is shown below.

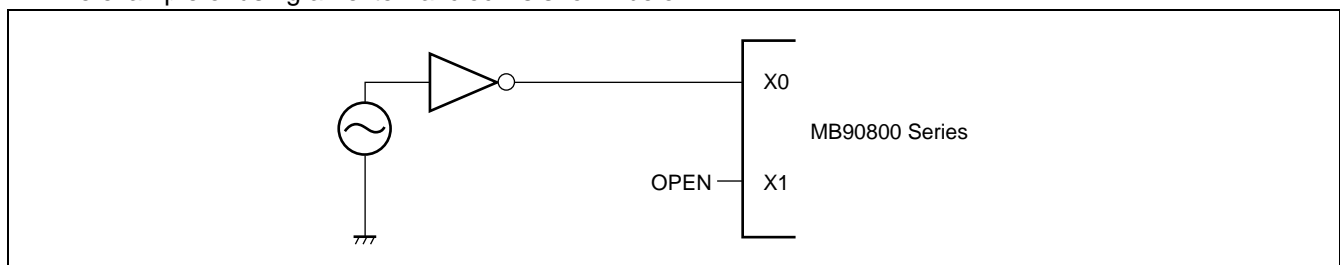

Please set X0A = GND and X1A = open without subclock mode.

The following figure shows the using sample.

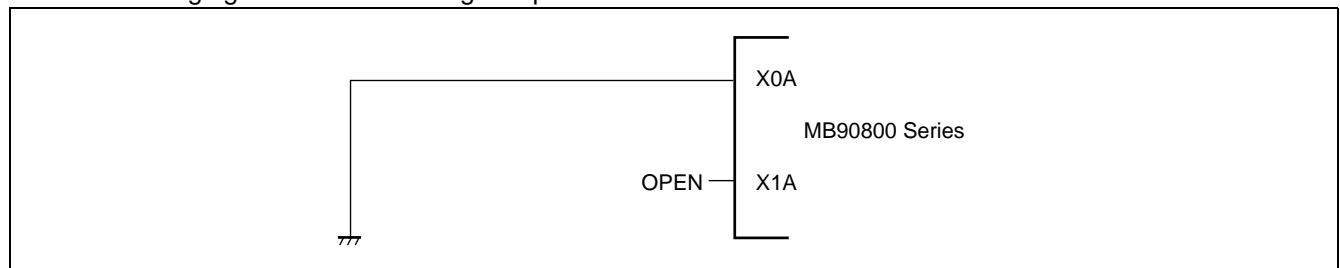

5. Treatment of power supply pins (V_{CC}/V_{SS})

In products with multiple V_{CC} or V_{SS} pins, the pins of the same potential are internally connected in the device to avoid abnormal operations including latch-up. However, you must connect all power supply pins to external power supply and a ground line to lower the electro-magnetic emission level, to prevent abnormal operation of strobe signals caused by the rise in the ground level, and to conform to the total output current rating.

Moreover, connect the current supply source with the V_{CC} and V_{SS} pins of this device at the low impedance.

It is also advisable to connect a ceramic capacitor of approximately 0.1 μF as a bypass capacitor between V_{CC} and V_{SS} near this device.

6. About Crystal oscillators circuit

Noise near the X0/X1 pins and X0A/X1A pins may cause the device to malfunction. Design the printed circuit board so that X0/X1 pins and X0A/X1A pins, the crystal oscillator (or the ceramic oscillator) and the bypass capacitor to ground are located as close to the device as possible.

It is strongly recommended to design the PC board artwork with the X0/X1 pins and X0A/X1A pins surrounded by ground plane because stable operation can be expected with such a layout.

Please ask the crystal maker to evaluate the oscillational characteristics of the crystal and this device.

7. Caution on Operations during PLL Clock Mode

On this microcontroller, if in case the crystal oscillator breaks off or an external reference clock input stops while the PLL clock mode is selected, a self-oscillator circuit contained in the PLL may continue its operation at its self-running frequency. However, Fujitsu will not guarantee results of operations if such failure occurs.

8. Stabilization of Supply Power Supply

A sudden change in the supply voltage may cause the device to malfunction even within the V_{CC} supply voltage operating range. Therefore, the V_{CC} supply voltage should be stabilized. For reference, the supply voltage should be controlled so that V_{CC} ripple variations (peak- to-peak values) at commercial frequencies (50 Hz/60 Hz) fall below 10% of the standard V_{CC} supply voltage and the coefficient of fluctuation does not exceed 0.1 V/ms at instantaneous power switching.

9. Note on Using the two-subsystem product as one-subsystem product

If you are using only one subsystem of the MB90800 series that come in one two-subsystem product, use it with X0A = V_{SS} and X1A = OPEN.

10. Write to FLASH

Ensure that you must write to FLASH at the operating voltage $V_{CC} = 3.0 \text{ V}$ to 3.6 V.

MB90800 Series

■ BLOCK DIAGRAM

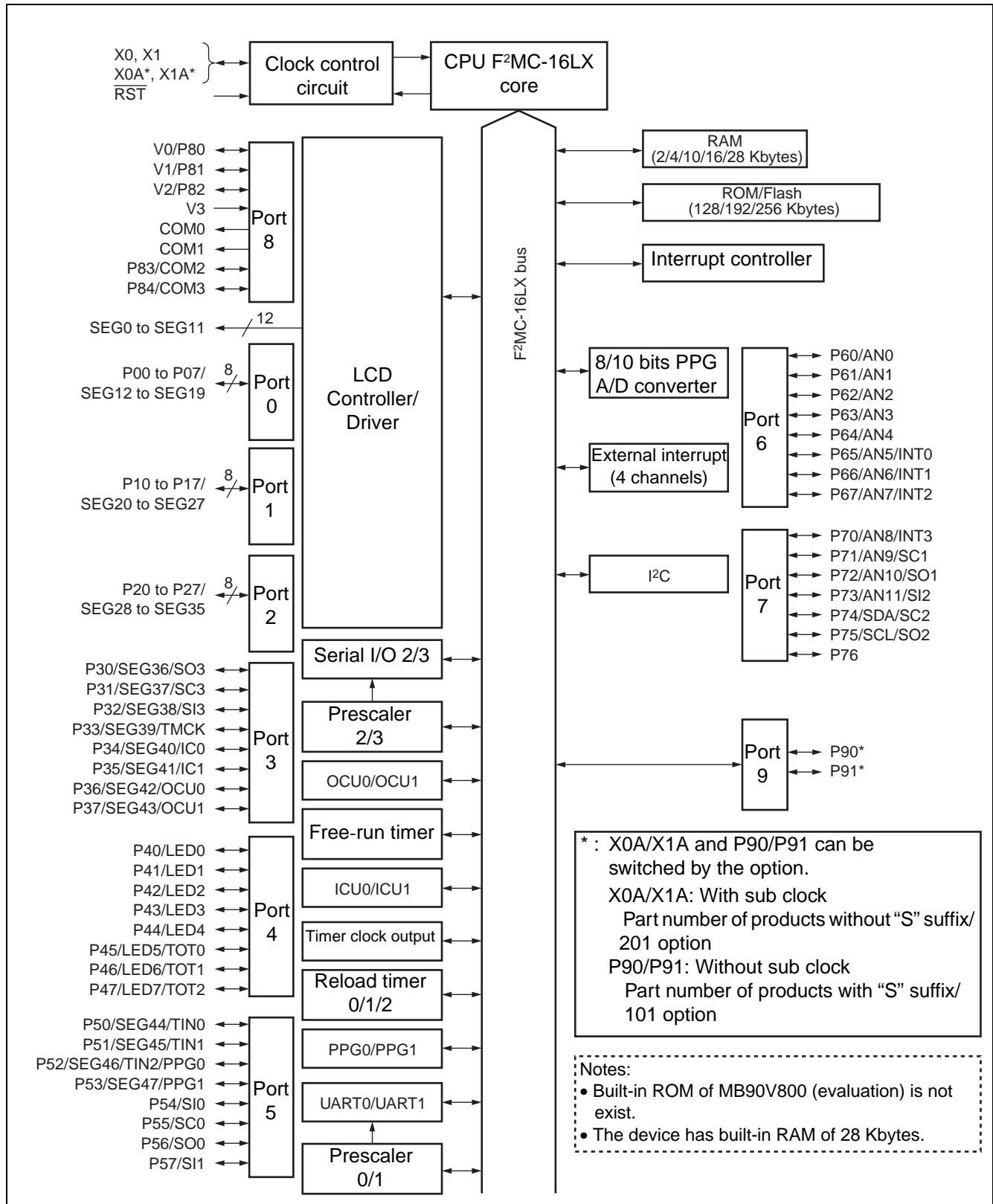

■ MEMORY MAP

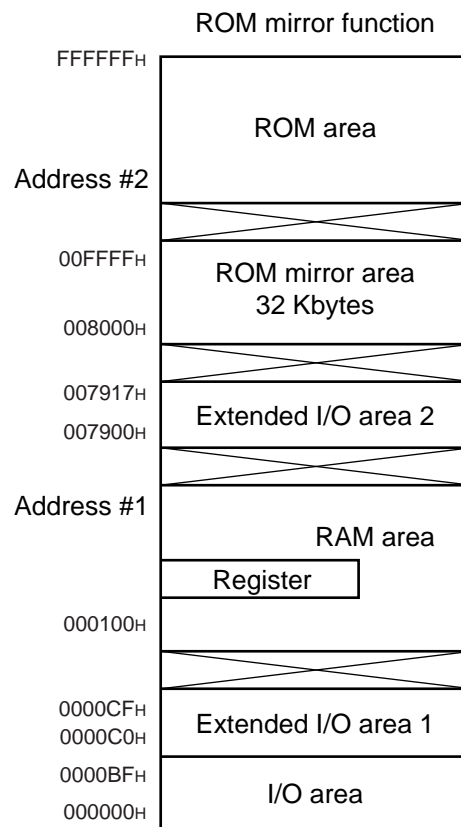

Part number	Address #1	Address #2
MB90803/S, MB90F803/S	0010FF _H	FE0000 _H
MB90F809/S	0028FF _H	FD0000 _H
MB90F804-101/201	0040FF _H	FC0000 _H
MB90V800-101/201	0070FF _H	F80000 _H *

* : ROM is not built into MB90V800.
F80000_H is ROM decipherment region on the tool side.

Memory Map of MB90800 Series

- Notes :
- When the ROM mirror function register has been set, the mirror image data at higher addresses ("FF4000_H to FFFFFFF_H") of bank FF is visible from the higher addresses ("008000_H to 00FFFF_H") of bank 00.
 - The ROM mirror function is for using the C compiler small model.
 - The lower 16-bit addresses of bank FF are equivalent to those of bank 00. Note that because the ROM area of bank FF exceeds 32 Kbytes, all data in the ROM area cannot be shown in mirror image in bank 00.
 - When the C compiler small model is used, the data table can be shown as mirror image at "008000_H to 00FFFF_H" by storing the data table at "FF8000_H to FFFFFFF_H". Therefore, data tables in the ROM area can be referenced without declaring the far addressing with the pointer.

MB90800 Series

■ F²MC-16L CPU Programming model

• Dedicated Registers

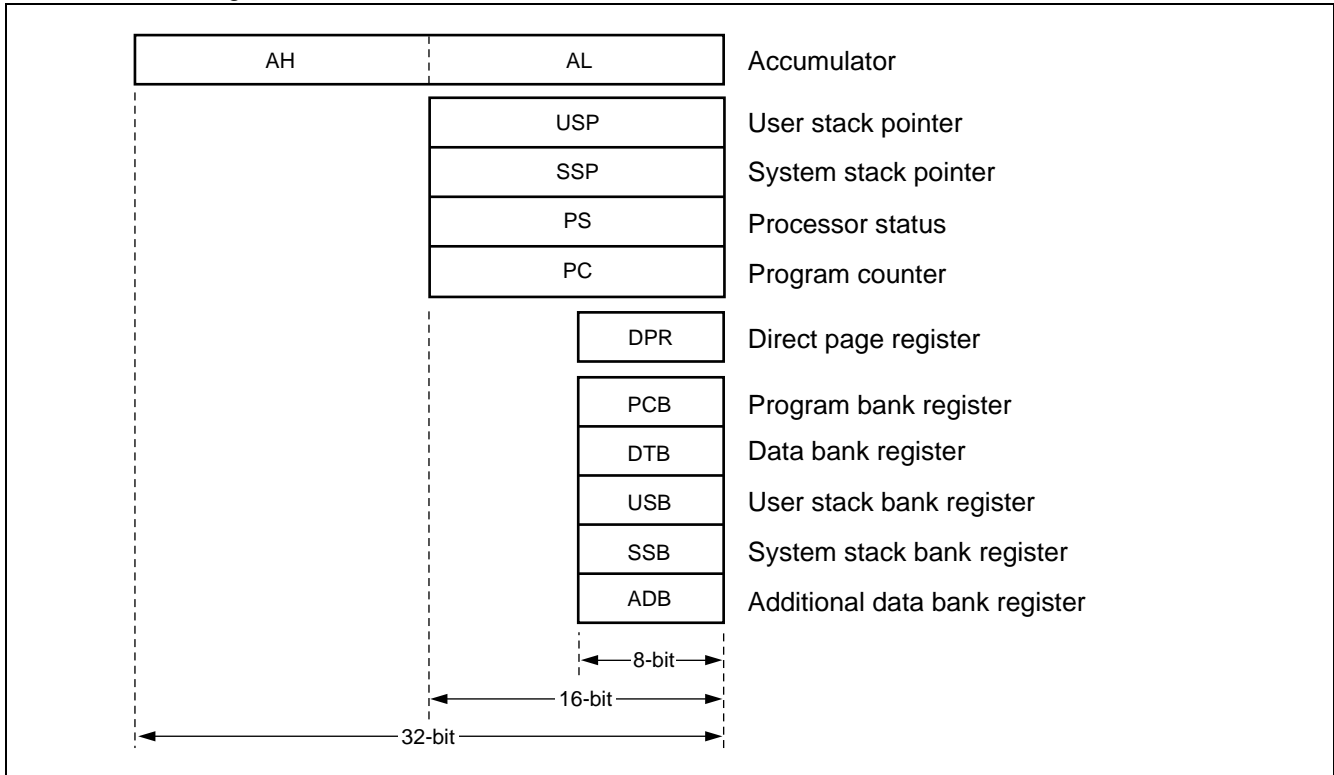

• General purpose registers

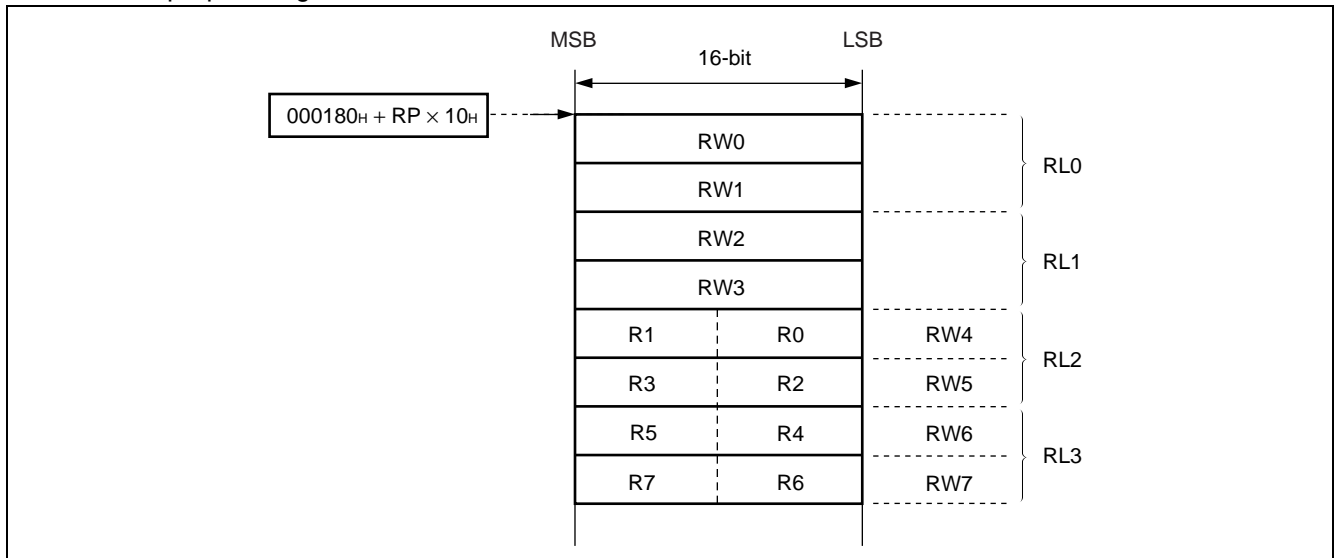

• Processor status

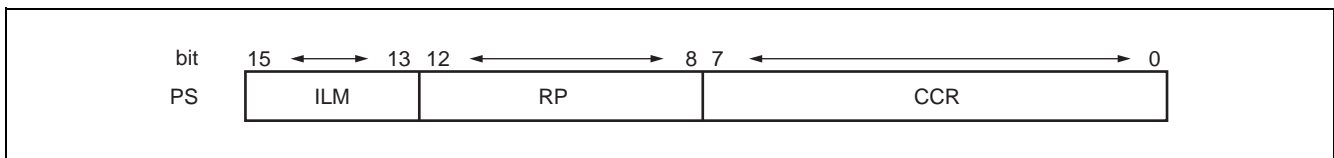

■ I/O MAP

Address	Register abbreviation	Register	Read/Write	Resource name	Initial Value
000000 _H	PDR0	Port 0 data register	R/W	Port 0	XXXXXXXX _B
000001 _H	PDR1	Port 1 data register	R/W	Port 1	XXXXXXXX _B
000002 _H	PDR2	Port 2 data register	R/W	Port 2	XXXXXXXX _B
000003 _H	PDR3	Port 3 data register	R/W	Port 3	XXXXXXXX _B
000004 _H	PDR4	Port 4 data register	R/W	Port 4	XXXXXXXX _B
000005 _H	PDR5	Port 5 data register	R/W	Port 5	XXXXXXXX _B
000006 _H	PDR6	Port 6 data register	R/W	Port 6	XXXXXXXX _B
000007 _H	PDR7	Port 7 data register	R/W	Port 7	-XXXXXXXX _B
000008 _H	PDR8	Port 8 data register	R/W	Port 8	---XXXX _B
000009 _H	PDR9	Port 9 data register	R/W	Port 9	-----XX _B
00000A _H to 00000F _H	Prohibited				
000010 _H	DDR0	Port 0 direction register	R/W	Port 0	00000000 _B
000011 _H	DDR1	Port 1 direction register	R/W	Port 1	00000000 _B
000012 _H	DDR2	Port 2 direction register	R/W	Port 2	00000000 _B
000013 _H	DDR3	Port 3 direction register	R/W	Port 3	00000000 _B
000014 _H	DDR4	Port 4 direction register	R/W	Port 4	00000000 _B
000015 _H	DDR5	Port 5 direction register	R/W	Port 5	00000000 _B
000016 _H	DDR6	Port 6 direction register	R/W	Port 6	00000000 _B
000017 _H	DDR7	Port 7 direction register	R/W	Port 7	-0000000 _B
000018 _H	DDR8	Port 8 direction register	R/W	Port 8	---00000 _B
000019 _H	DDR9	Port 9 direction register	R/W	Port 9	-----00 _B
00001A _H to 00001D _H	Prohibited				
00001E _H	ADER0	Analog input enable 0 register	R/W	Port 6, A/D	11111111 _B
00001F _H	ADER1	Analog input enable 1 register	R/W	Port 7, A/D	----1111 _B
000020 _H	SMR0	Serial mode register	R/W	UART0	00000-00 _B
000021 _H	SCR0	Serial control register	R/W		00000100 _B
000022 _H	SIDR0/ SODR0	Serial input/output register	R/W		XXXXXXXX _B
000023 _H	SSR0	Serial data register	R/W		00001000 _B
000024 _H	Prohibited				
000025 _H	CDCR0	Communication prescaler control register	R/W	Prescaler 0	00--0000 _B
000026 _H 000027 _H	Prohibited				

(Continued)

MB90800 Series

Address	Register abbreviation	Register	Read/Write	Resource name	Initial Value
000028 _H	SMR1	Serial mode register	R/W	UART1	0 0 0 0 0 - 0 0 _B
000029 _H	SCR1	Serial control register	R/W, W		0 0 0 0 0 1 0 0 _B
00002A _H	SIDR1/ SODR1	Serial input/output register	R/W		XXXXXXXX _B
00002B _H	SSR1	Serial data register	R/W, R		0 0 0 0 1 0 0 0 _B
00002C _H	Prohibited				
00002D _H	CDCR1	Communication prescaler control register	R/W	Prescaler 1	0 0 - - 0 0 0 0 _B
00002E _H	Prohibited				
00002F _H	Prohibited				
000030 _H	ENIR	Interrupt/DTP enable	R/W	External interrupt	- - - - 0 0 0 0 _B
000031 _H	EIRR	Interrupt/DTP source	R/W		- - - - XXXX _B
000032 _H	ELVR	Request level set register	R/W		0 0 0 0 0 0 0 0 _B
000033 _H	Prohibited				
000034 _H	ADCS0	Control status register (lower)	R/W	A/D converter	0 0 - - - - - B
000035 _H	ADCS1	Control status register (upper)	W, R/W		0 0 0 0 0 0 0 0 _B
000036 _H	ADCR0	Data register (lower)	R		XXXXXXXX _B
000037 _H	ADCR1	Data register (upper)	R, W		0 0 1 0 1 - XX _B
000038 _H	Prohibited				
000039 _H	ADMR	A/D conversion channel set register	R/W	A/D converter	0 0 0 0 0 0 0 0 _B
00003A _H	CPCLR	Compare clear register	R/W	16-bit free-run timer	XXXXXXXX _B
00003B _H					XXXXXXXX _B
00003C _H	TCDT	Timer counter data register	R/W		0 0 0 0 0 0 0 0 _B
00003D _H					0 0 0 0 0 0 0 0 _B
00003E _H	TCCSL	Timer counter control/status register (lower)	R/W		0 0 0 0 0 0 0 0 _B
00003F _H	TCCSH	Timer counter control/status register (upper)	R/W		0 - - 0 0 0 0 0 _B
000040 _H to 000043 _H	Prohibited				
000044 _H	IPCP0	Input capture data register 0	R	Input Capture 0/1	XXXXXXXX _B
000045 _H					XXXXXXXX _B
000046 _H	IPCP1	Input capture data register 1			XXXXXXXX _B
000047 _H					XXXXXXXX _B
000048 _H	ICS01	Control status register	R/W		0 0 0 0 0 0 0 0 _B
000049 _H	Prohibited				
00004A _H	OCCP0	Compare register 0	R/W	Output compare 0	0 0 0 0 0 0 0 0 _B
00004B _H					0 0 0 0 0 0 0 0 _B
00004C _H	OCCP1	Compare register 1	R/W	Output compare 1	0 0 0 0 0 0 0 0 _B
00004D _H					0 0 0 0 0 0 0 0 _B

(Continued)

MB90800 Series

Address	Register abbreviation	Register	Read/Write	Resource name	Initial Value
00004E _H	OCSL	Control status register (lower)	R/W	Output Compare 0/1	0 0 0 0 -- 0 0 _B
00004F _H	OCSH	Control status register (upper)	R/W		-- 0 0 0 0 0 _B
000050 _H	TMCSR0L	Timer control status register (lower)	R/W	16-bit reload timer 0	0 0 0 0 0 0 0 0 _B
000051 _H	TMCSR0H	Timer control status register (upper)	R/W		-- -- 0 0 0 0 _B
000052 _H	TMR0/ TMRLR0	16-bit timer register/Reload register	R/W		XXXXXXXX _B
000053 _H					XXXXXXXX _B
000054 _H	TMCSR1L	Timer control status register (lower)	R/W	16-bit reload timer 1	0 0 0 0 0 0 0 0 _B
000055 _H	TMCSR1H	Timer control status register (upper)	R/W		-- -- 0 0 0 0 _B
000056 _H	TMR1/ TMRLR1	16-bit timer register/Reload register	R/W		XXXXXXXX _B
000057 _H					XXXXXXXX _B
000058 _H	TMCSR2L	Timer control status register (lower)	R/W	16-bit reload timer 2	0 0 0 0 0 0 0 0 _B
000059 _H	TMCSR2H	Timer control status register (upper)	R/W		-- -- 0 0 0 0 _B
00005A _H	TMR2/ TMRLR2	16-bit timer register/Reload register	R/W		XXXXXXXX _B
00005B _H					XXXXXXXX _B
00005C _H	LCRL	LCDC control register (lower)	R/W	LCD controller/ driver	0 0 0 1 0 0 0 0 _B
00005D _H	LCRH	LCDC control register (upper)	R/W		0 0 0 0 0 0 0 0 _B
00005E _H	LCRR	LCDC range register	R/W		0 0 0 0 0 0 0 0 _B
00005F _H	Prohibited				
000060 _H	SMCS0	Serial mode control status register	R, R/W	SIO (Extended Serial I/O)	0 0 0 0 0 0 1 0 _B
000061 _H			R/W		-- -- 0 0 0 0 _B
000062 _H	SDR0	Serial Data Register	R/W		XXXXXXXX _B
000063 _H	SDCR0	Communication prescaler control register	R/W	Communication prescaler (SIO)	0 -- -- 0 0 0 0 _B
000064 _H	SMCS1	Serial mode control status register	R, R/W	SIO (Extended Serial I/O)	0 0 0 0 0 0 1 0 _B
000065 _H			R/W		-- -- 0 0 0 0 _B
000066 _H	SDR1	Serial Data Register	R/W		XXXXXXXX _B
000067 _H	SDCR1	Communication prescaler control register	R/W	Communication prescaler (SIO)	0 -- -- 0 0 0 0 _B
000068 _H	Prohibited				
000069 _H	Prohibited				
00006A _H	IBSR	I ² C status register	R	I ² C	0 0 0 0 0 0 0 0 _B
00006B _H	IBCR	I ² C control register	R/W		0 0 0 0 0 0 0 0 _B
00006C _H	ICCR	I ² C clock control register	R/W		XX0XXXXX _B
00006D _H	IADR	I ² C address register	R/W		XXXXXXXX _B
00006E _H	IDAR	I ² C data register	R/W		XXXXXXXX _B
00006F _H	ROMM	ROM mirror function select register	R/W, W		ROM mirror

(Continued)

MB90800 Series

Address	Register abbreviation	Register	Read/Write	Resource name	Initial Value
000070 _H	PDCRL0	PDCRL0/PDCRH0 PPG down counter register	R	16-bit PPG0	1 1 1 1 1 1 1 1 _B
000071 _H	PDCRH0				1 1 1 1 1 1 1 1 _B
000072 _H	PCSRL0	PCSRL0/PCSRH0 PPG cycle set register	W		XXXXXXXX _B
000073 _H	PCSRH0				XXXXXXXX _B
000074 _H	PDUTL0	PDUTL0/PDUTH0 PPG duty setting register	W		XXXXXXXX _B
000075 _H	PDUTH0				XXXXXXXX _B
000076 _H	PCNTL0	PCNTL0/PCNTH0 PPG control status register	R/W		-- 0 0 0 0 0 _B
000077 _H	PCNTH0				0 0 0 0 0 0 0 - _B
000078 _H	PDCRL1	PDCRL1/PDCRH1 PPG down counter register	R	16-bit PPG1	1 1 1 1 1 1 1 1 _B
000079 _H	PDCRH1				1 1 1 1 1 1 1 1 _B
00007A _H	PCSRL1	PCSRL1/PCSRH1 PPG cycle set register	W		XXXXXXXX _B
00007B _H	PCSRH1				XXXXXXXX _B
00007C _H	PDUTL1	PDUTL1/PDUTH1 PPG duty setting register	W		XXXXXXXX _B
00007D _H	PDUTH1				XXXXXXXX _B
00007E _H	PCNTL1	PCNTL1/PCNTH1 PPG control status register	R/W		-- 0 0 0 0 0 _B
00007F _H	PCNTH1				0 0 0 0 0 0 0 - _B
000080 _H to 000095 _H	(Reserved)				
000096 _H	Prohibited				
000097 _H	(Reserved)				
000098 _H to 00009D _H	Prohibited				
00009E _H	PACSR	ROM correction control register	R/W	ROM Correction	0 0 0 0 0 0 0 _B
00009F _H	DIRR	Delayed interrupt source generated/release register	R/W	Delayed interrupt	- - - - - 0 _B
0000A0 _H	LPMCR	Low power consumption mode control register	R/W, W	Low power consumption control circuit	0 0 0 1 1 0 0 _B
0000A1 _H	CKSCR	Clock selector register	R/W, R		1 1 1 1 1 1 0 _B
0000A2 _H to 0000A7 _H	Prohibited				
0000A8 _H	WDTC	Watchdog timer control register	R, W	Watchdog timer	XXXXX 1 1 1 _B
0000A9 _H	TBTC	Time-base timer control register	R/W, W	Time-base timer	1 - - 0 0 1 0 0 _B
0000AA _H	WTC	Watch timer control register	R/W, R	Watch timer (Sub clock)	1 X 0 1 1 0 0 0 _B
0000AB _H to 0000AD _H	Prohibited				

(Continued)

(Continued)

Address	Register abbreviation	Register	Read/Write	Resource name	Initial Value
0000AE _H	FMCS	Flash control register	R/W	Flash I/F	0 0 0 X 0 0 0 0 _B
0000AF _H	TMCS	Timer clock output control register	R/W	Timer clock divide	XXXXXX 0 0 0 _B
0000B0 _H	ICR00	Interrupt control register 00	R/W, W, R	Interrupt controller	0 0 0 0 0 1 1 1 _B
0000B1 _H	ICR01	Interrupt control register 01	R/W, W, R		0 0 0 0 0 1 1 1 _B
0000B2 _H	ICR02	Interrupt control register 02	R/W, W, R		0 0 0 0 0 1 1 1 _B
0000B3 _H	ICR03	Interrupt control register 03	R/W, W, R		0 0 0 0 0 1 1 1 _B
0000B4 _H	ICR04	Interrupt control register 04	R/W, W, R		0 0 0 0 0 1 1 1 _B
0000B5 _H	ICR05	Interrupt control register 05	R/W, W, R		0 0 0 0 0 1 1 1 _B
0000B6 _H	ICR06	Interrupt control register 06	R/W, W, R		0 0 0 0 0 1 1 1 _B
0000B7 _H	ICR07	Interrupt control register 07	R/W, W, R		0 0 0 0 0 1 1 1 _B
0000B8 _H	ICR08	Interrupt control register 08	R/W, W, R		0 0 0 0 0 1 1 1 _B
0000B9 _H	ICR09	Interrupt control register 09	R/W, W, R		0 0 0 0 0 1 1 1 _B
0000BA _H	ICR10	Interrupt control register 10	R/W, W, R		0 0 0 0 0 1 1 1 _B
0000BB _H	ICR11	Interrupt control register 11	R/W, W, R		0 0 0 0 0 1 1 1 _B
0000BC _H	ICR12	Interrupt control register 12	R/W, W, R		0 0 0 0 0 1 1 1 _B
0000BD _H	ICR13	Interrupt control register 13	R/W, W, R		0 0 0 0 0 1 1 1 _B
0000BE _H	ICR14	Interrupt control register 14	R/W, W, R		0 0 0 0 0 1 1 1 _B
0000BF _H	ICR15	Interrupt control register 15	R/W, W, R		0 0 0 0 0 1 1 1 _B
0000CA _H	FWR0	Flash Program Control Register 0	R/W	Flash I/F (MB90F803/S only object)	0 0 0 0 0 0 0 0 _B
0000CB _H	FWR1	Flash Program Control Register 1	R/W		0 0 0 0 0 0 0 0 _B
0000CC _H	SSR0	Sector Conversion Setting Register	R/W		0 0 XXXXXX 0 _B
001FF0 _H	PADR0	Program address detection register 0	R/W	Address matching detection function	XXXXXXXX _B
001FF1 _H					XXXXXXXX _B
001FF2 _H					XXXXXXXX _B
001FF3 _H	PADR1	Program address detection register 1	R/W		XXXXXXXX _B
001FF4 _H					XXXXXXXX _B
001FF5 _H					XXXXXXXX _B
007900 _H to 007917 _H	VRAM	LCD display RAM	R/W	LCD controller/ driver	XXXXXXXX _B

- Read/Write
R/W : Readable and Writable
R : Read only
W : Write only

- Initial values
0 : Initial Value is "0".
1 : Initial Value is "1".
X : Initial Value is Indeterminate.
- : Unused bit

MB90800 Series

■ INTERRUPT SOURCES, INTERRUPT VECTORS AND INTERRUPT CONTROL REGISTERS

Interrupt source	EI ² OS readiness	Interrupt vector		Interrupt control register		Priority	
		Number*	Address	ICR	Address		
Reset	×	#08	08 _H	FFFFDC _H	—	High ↑	
INT 9 instruction	×	#09	09 _H	FFFFD8 _H	—		
Exceptional treatment	×	#10	0A _H	FFFFD4 _H	—		
DTP/External interrupt ch.0	○	#11	0B _H	FFFFD0 _H	ICR00		0000B0 _H
DTP/External interrupt ch.1	○	#13	0D _H	FFFFC8 _H	ICR01		0000B1 _H
Serial I/O ch.2	×	#15	0F _H	FFFFC0 _H	ICR02		0000B2 _H
DTP/External interrupt ch.2/ch.3	○	#16	10 _H	FFFFBC _H			
Serial I/O ch.3	×	#17	11 _H	FFFFB8 _H	ICR03		0000B3 _H
16-bit free-run timer	○	#18	12 _H	FFFFB4 _H			
Watch timer	×	#19	13 _H	FFFFB0 _H	ICR04		0000B4 _H
16-bit Reload Timer ch.2	○	#21	15 _H	FFFFA8 _H	ICR05		0000B5 _H
16-bit Reload Timer ch.0	△	#23	17 _H	FFFFA0 _H	ICR06		0000B6 _H
16-bit Reload Timer ch.1	△	#24	18 _H	FFFF9C _H			
Input capture ch.0	△	#25	19 _H	FFFF98 _H	ICR07		0000B7 _H
Input capture ch.1	△	#26	1A _H	FFFF94 _H			
PPG timer ch.0 counter-borrow	○	#27	1B _H	FFFF90 _H	ICR08	0000B8 _H	
Output compare match	○	#29	1D _H	FFFF88 _H	ICR09	0000B9 _H	
PPG timer ch.1 counter-borrow	○	#31	1F _H	FFFF80 _H	ICR10	0000BA _H	
Time-base timer	×	#33	21 _H	FFFF78 _H	ICR11	0000BB _H	
UART0 reception end	◎	#35	23 _H	FFFF70 _H	ICR12	0000BC _H	
UART0 transmission end	△	#36	24 _H	FFFF6C _H			
A/D converter conversion termination	○	#37	25 _H	FFFF68 _H	ICR13	0000BD _H	
I ² C Interface	×	#38	26 _H	FFFF64 _H			
UART1 : Reception	◎	#39	27 _H	FFFF60 _H	ICR14	0000BE _H	
UART1 : Transmission	△	#40	28 _H	FFFF5C _H			
Flash memory status	×	#41	29 _H	FFFF58 _H	ICR15	0000BF _H	
Delayed interrupt output module	×	#42	2A _H	FFFF54 _H			

○ : Available

×

◎ : Available EI²OS function is provided.

△ : Available when a cause of interrupt sharing a same ICR is not used.

* : When interrupts of the same level are output at the same time, the interrupt with the smallest interrupt vector number has the priority.

- For a resource that has two interrupt causes in the same interrupt control register (ICR), use of EI²OS is enabled, EI²OS is started upon detection of one of the interrupt causes. As interrupts other than the start cause are masked during EI²OS start, masking one of the interrupt causes is recommended when using EI²OS.
- For a resource that has two interrupt causes in the same interrupt control register (ICR), the interrupt flag is cleared by an EI²OS interrupt clear signal.

■ PERIPHERAL RESOURCES

1. I/O port

The I/O ports function to output data from the CPU to I/O pins by setting their port data register (PDR) and send signals input to I/O pins to the CPU. In addition, the port can randomly set the direction of the input/output of the port in bit by the port direction register (DDR).

The MB90800 series has 68 (70 ports when the subclock is not used) input/output pins. Port0 to port8 (port0 to port9 when product without the subclock is used) are input/output port.

(1) Port data register

PDR0	bit	7	6	5	4	3	2	1	0	Initial Value	Access
Address : 000000H		P07	P06	P05	P04	P03	P02	P01	P00	Indeterminate	R/W*
PDR1	bit	15	14	13	12	11	10	9	8		
Address : 000001H		P17	P16	P15	P14	P13	P12	P11	P10	Indeterminate	R/W*
PDR2	bit	7	6	5	4	3	2	1	0		
Address : 000002H		P27	P26	P25	P24	P23	P22	P21	P20	Indeterminate	R/W*
PDR3	bit	15	14	13	12	11	10	9	8		
Address : 000003H		P37	P36	P35	P34	P33	P32	P31	P30	Indeterminate	R/W*
PDR4	bit	7	6	5	4	3	2	1	0		
Address : 000004H		P47	P46	P45	P44	P43	P42	P41	P40	Indeterminate	R/W*
PDR5	bit	15	14	13	12	11	10	9	8		
Address : 000005H		P57	P56	P55	P54	P53	P52	P51	P50	Indeterminate	R/W*
PDR6	bit	7	6	5	4	3	2	1	0		
Address : 000006H		P67	P66	P65	P64	P63	P62	P61	P60	Indeterminate	R/W*
PDR7	bit	15	14	13	12	11	10	9	8		
Address : 000007H		—	P76	P75	P74	P73	P72	P71	P70	Indeterminate	R/W*
PDR8	bit	7	6	5	4	3	2	1	0		
Address : 000008H		—	—	—	P84	P83	P82	P81	P80	Indeterminate	R/W*
PDR9	bit	15	14	13	12	11	10	9	8		
Address : 000009H		—	—	—	—	—	—	P91	P90	Indeterminate	R/W*

- : Unused

* : R/W access to I/O ports is a bit different in behavior from R/W access to memory as follows

- Input mode
 - When reading : Read the corresponding pin level.
 - When writing : Write into the latch for the output.
- Output mode
 - When reading : Read the value of the data register latch.
 - When writing : Write into the corresponding pin.

MB90800 Series

(2) Port direction register

Register	bit	7	6	5	4	3	2	1	0	Initial Value	Access
DDR0	Address : 000010 _H	D07	D06	D05	D04	D03	D02	D01	D00	00000000 _B	R/W
DDR1	Address : 000011 _H	D17	D16	D15	D14	D13	D12	D11	D10	00000000 _B	R/W
DDR2	Address : 000012 _H	D27	D26	D25	D24	D23	D22	D21	D20	00000000 _B	R/W
DDR3	Address : 000013 _H	D37	D36	D35	D34	D33	D32	D31	D30	00000000 _B	R/W
DDR4	Address : 000014 _H	D47	D46	D45	D44	D43	D42	D41	D40	00000000 _B	R/W
DDR5	Address : 000015 _H	D57	D56	D55	D54	D53	D52	D51	D50	00000000 _B	R/W
DDR6	Address : 000016 _H	D67	D66	D65	D64	D63	D62	D61	D60	00000000 _B	R/W
DDR7	Address : 000017 _H	—	D76	D75	D74	D73	D72	D71	D70	- 0000000 _B	R/W
DDR8	Address : 000018 _H	—	—	—	D84	D83	D82	D81	D80	- - - 00000 _B	R/W
DDR9	Address : 000019 _H	—	—	—	—	—	—	D91	D90	- - - - - 00 _B	R/W

- : Unused

When each terminal functions as a port, each correspondent pin are controlled by the port direction register to following;

0 : Input mode

1 : Output mode This bit becomes "0" after a reset.

Note : When accessing this register by using the instruction of the read modify write system (instructions such as bit set) is mode, the bit targeted by an instruction becomes the defined value. However, the content of the output register set to input with the other changes to input value of the pin at that time. Therefore, be sure to write an expected value into PDR firstly, and then set DDR and finally change to the output when changing the input pin to the output pin is made.

(3) Analog Input Enable register

ADER0	bit	7	6	5	4	3	2	1	0	Initial Value	Access
Address : 00001EH		ADE7	ADE6	ADE5	ADE4	ADE3	ADE2	ADE1	ADE0	11111111 _B	R/W
ADER1	bit	15	14	13	12	11	10	9	8	----1111 _B	R/W
Address : 00001FH		—	—	—	—	ADE11	ADE10	ADE9	ADE8		
- : Unused											

Each pin of port 6 is controlled by the analog input enable register as follow.

0 : Port input/output mode.

1 : Analog input mode. This bit becomes "1" after a reset.

2. UART

UART is a serial I/O port for asynchronous (start-stop synchronization) communication or CLK synchronous communications.

- With full-duplex double buffer
- Clock asynchronous (start-stop synchronization) , CLK synchronous communications (no start-bit/stop-bit) can be used.
- Supports multi-processor mode
- Built-in dedicated baud rate generator

Asynchronous : 120192/60096/30048/15024/781.25 K/390.625 kbps

CLK synchronous : 25 M/12.5 M/6.25 M/3.125 M/1.5627 M/781.25 kbps

- Variable baud rate can be set by an external clock.
- 7 bits data length (only asynchronous normal mode) /8 bits length
- Master/slave type communication function (at multiprocessor mode) : The communication between one (master) to n (slave) can be operating.
- Error detection functions (parity, framing, overrun)
- Transmission signal format is NRZ

(1) Register list

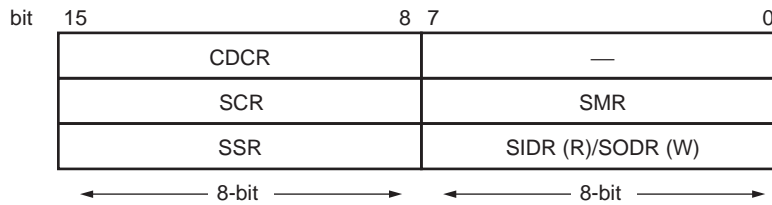

Serial mode register (SMR0, SMR1)

bit	7	6	5	4	3	2	1	0	Initial Value		
Address :	000020H	000028H	MD1	MD0	CS2	CS1	CS0	—	SCKE	SOE	00000 - 00B
			R/W	R/W	R/W	R/W	R/W	—	R/W	R/W	Read/Write

Serial control register(SCR0, SCR1)

bit	15	14	13	12	11	10	9	8	Initial Value		
Address :	000021H	000029H	PEN	P	SBL	CL	A/D	REC	RXE	TXE	00000100B
			R/W	R/W	R/W	R/W	R/W	W	R/W	R/W	Read/Write

Serial input/output register (SIDR0, SIDR1/SODR0, SODR1)

bit	7	6	5	4	3	2	1	0	Initial Value		
Address :	000022H	00002AH	D7	D6	D5	D4	D3	D2	D1	D0	XXXXXXXXB
			R/W	R/W	R/W	R/W	R/W	R/W	R/W	R/W	Read/Write

Serial Data Register (SSR0, SSR1)

bit	15	14	13	12	11	10	9	8	Initial Value		
Address :	000023H	00002BH	PE	ORE	FRE	RDRF	TDRE	BDS	RIE	TIE	00001000B
			R	R	R	R	R	R/W	R/W	R/W	Read/Write

Communication prescaler control register (CDCR0, CDCR1)

bit	15	14	13	12	11	10	9	8	Initial Value		
Address :	000025H	00002DH	MD	URST	—	—	Reserved	DIV2	DIV1	DIV0	00 - - 0000B
			R/W	R/W	—	—	R/W	R/W	R/W	R/W	Read/Write

- : Unused

MB90800 Series

(2) Block Diagram

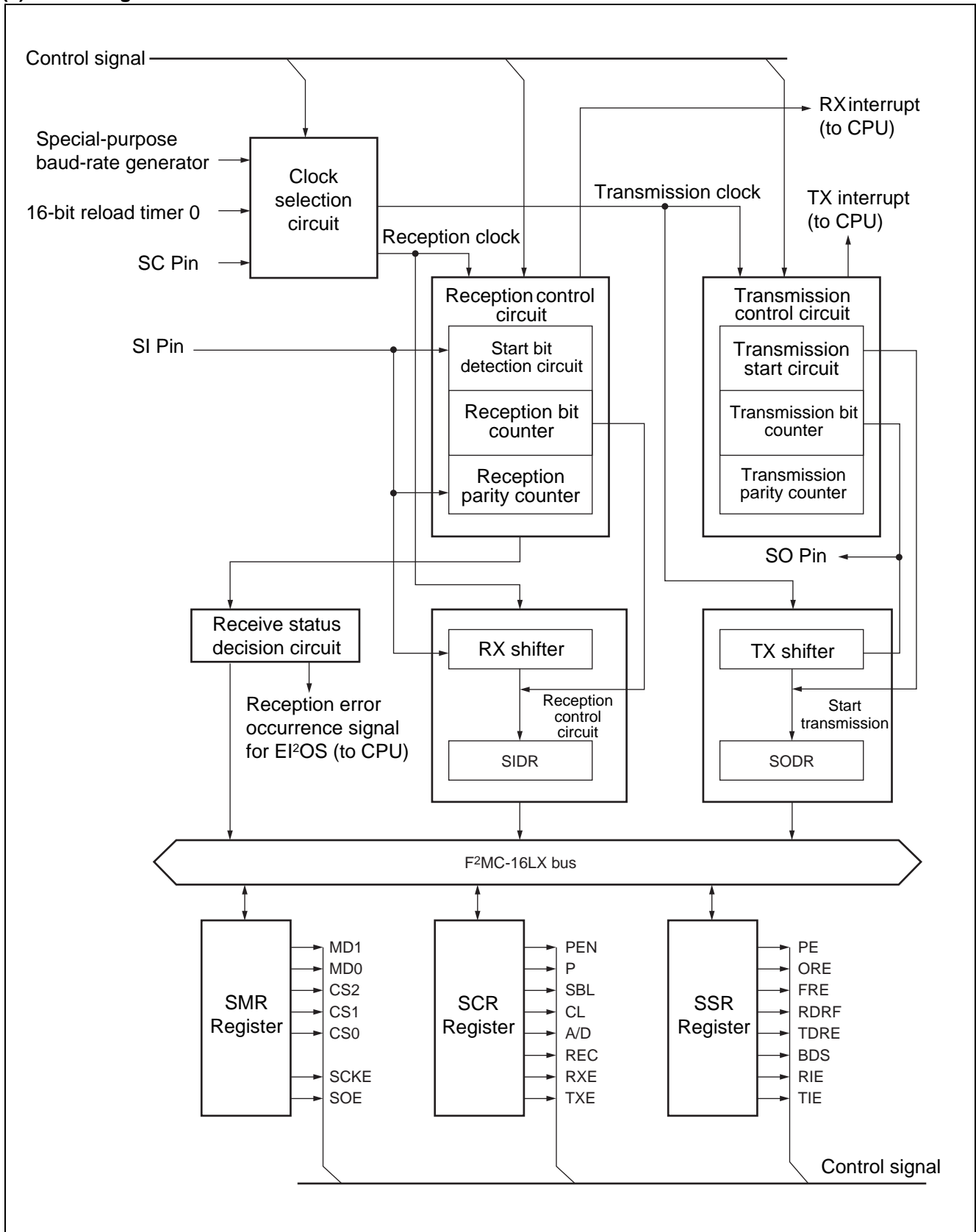

3. I²C Interface

I²C interface is the serial input/output port that support Inter IC BUS and functions as the master/slave device on the I²C bus. MB90800 series have 1 channel of the built-in I²C interface.

It has the features of I²C interface below.

- Master/slave sending and receiving
- Arbitration function
- Clock synchronization function
- Slave address and general call address detection function
- Detecting transmitting direction function
- Repeat generating and detecting function of the start conditions
- Bus error detection function
- The forwarding rate can be supported to 100 kbps.

(1) Register list

I ² C status register (IBSR)									Initial Value
Address :00006A _H	7	6	5	4	3	2	1	0	0000000 _B
	BB	RSC	AL	LRB	TRX	AAS	GCA	FBT	
	R	R	R	R	R	R	R	R	Read/Write
I ² C control register (IBCR)									Initial Value
Address :00006B _H	15	14	13	12	11	10	9	8	0000000 _B
	BER	BEIE	SCC	MSS	ACK	GCAA	INTE	INT	
	R/W	R/W	R/W	R/W	R/W	R/W	R/W	R/W	Read/Write
I ² C clock control register (ICCR)									Initial Value
Address :00006C _H	7	6	5	4	3	2	1	0	XX0XXXX _B
	—	—	EN	CS4	CS3	CS2	CS1	CS0	
	—	—	R/W	R/W	R/W	R/W	R/W	R/W	Read/Write
I ² C data register(IDAR)									Initial Value
Address :00006E _H	15	14	13	12	11	10	9	8	XXXXXXXX _B
	D7	D6	D5	D4	D3	D2	D1	D0	
	R/W	R/W	R/W	R/W	R/W	R/W	R/W	R/W	Read/Write
I ² C address register (IADR)									Initial Value
Address :00006D _H	7	6	5	4	3	2	1	0	XXXXXXXX _B
	—	A6	A5	A4	A3	A2	A1	A0	
	—	R/W	R/W	R/W	R/W	R/W	R/W	R/W	Read/Write
-	: Unused								

(2) Block Diagram

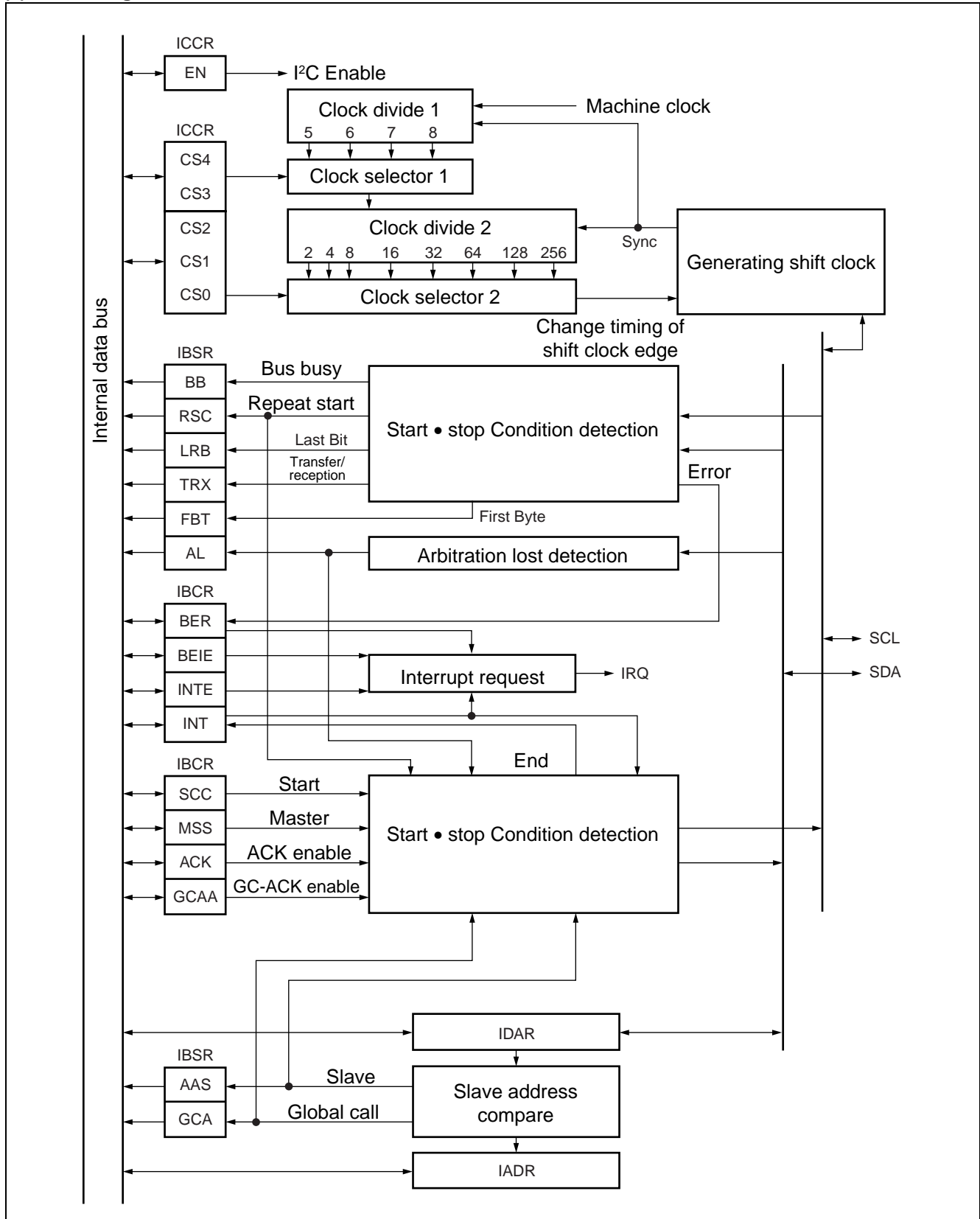

4. Extended I/O serial interface

The extended I/O serial interface is a serial I/O interface that can transfer data through the adoption of 8-bit × 2 channels configured clock synchronization scheme. The extended I/O serial interface also has two alternatives in data transfer called LSB first and MSB first.

The serial I/O interface operates in two modes:

- Internal shift clock mode : Transfer data in sync with the internal clock.
- External shift clock mode : Transfers data in sync with the clock input through an external pin (SC) . In this mode, transfer operation performed by the CPU instruction is also available by operating the general-use port sharing an external pin (SC) .

(1) Register list

Serial mode control status register (SMCS0, SMCS1)										
Address :	bit	15	14	13	12	11	10	9	8	Initial Value
: 000060H		SMD2	SMD1	SMD0	SIE	SIR	BUSY	STOP	STRT	00000010 _B
: 000064H		R/W	R/W	R/W	R/W	R/W	R	R/W	R/W	Read/Write
Address :	bit	7	6	5	4	3	2	1	0	Initial Value
: 000061H		—	—	—	—	MODE	BDS	SOE	SCOE	----0000 _B
: 000065H		—	—	—	—	R/W	R/W	R/W	R/W	Read/Write
Serial Data Register (SDR0, SDR1)										
Address :	bit	7	6	5	4	3	2	1	0	Initial Value
: 000062H		D7	D6	D5	D4	D3	D2	D1	D0	XXXXXXXX _B
: 000066H		R/W	R/W	R/W	R/W	R/W	R/W	R/W	R/W	Read/Write
Communication Prescaler control register (SDCR0, SDCR1)										
Address :	bit	15	14	13	12	11	10	9	8	Initial Value
: 000063H		MD	—	—	—	Reserved	DIV2	DIV1	DIV0	0---0000 _B
: 000067H		R/W	—	—	—	R/W	R/W	R/W	R/W	Read/Write
- : Unused										

MB90800 Series

(2) Block Diagram

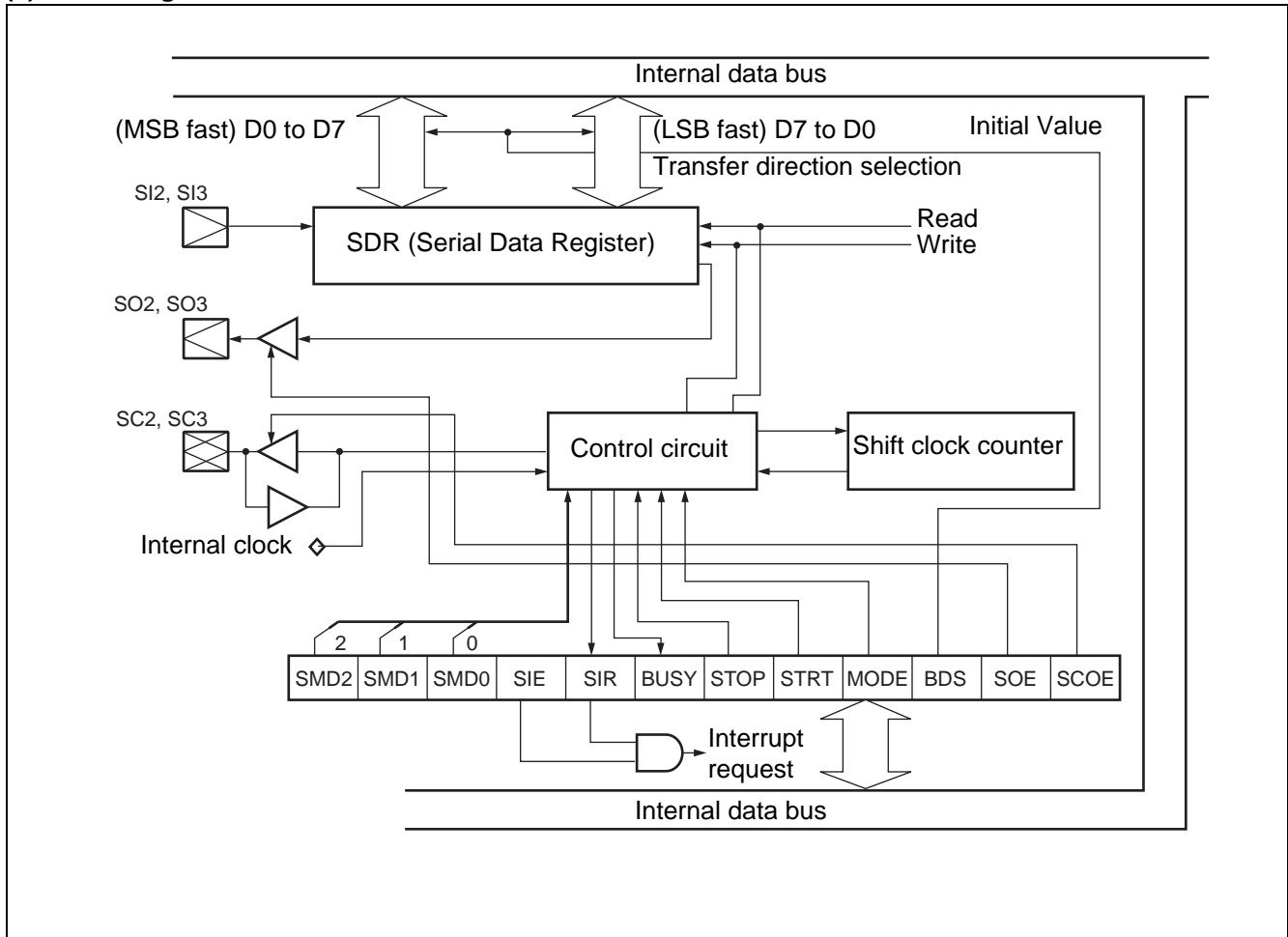

5. 8/10-bit A/D converter

The feature of 8/10-bit A/D converter is shown as follows.

- conversion time : 3.1 μ s minimum per 1 channel

(78 machine cycle/at machine clock 25 MHz/including the sampling time)

- Sampling time : 2.0 μ s minimum per 1channel

(50 machine cycle/at machine clock 25 MHz)

- Uses RC-type successive approximation conversion method with a sample & hold circuit
- 8-bit resolution or 10-bit resolution can be select.
- 12 channel program-selectable analog inputs.

Single conversion mode : Convert specified 1 channel

Scan conversion mode : Continuous plural channels (maximum 12 channels can be programmed) are converted.

Continuous conversion mode : Selected channel converted continuously.

Stop conversion time : Perform conversion for one channel, then pause it to wait for the next activation trigger (synchronizes the conversion start timing)

- EI²OS can be activated by outputting the interrupt request when the A/D conversion completes.
- If the A/D conversion is performed under the condition of the interrupt enable, the converting data will be protected.
- Selectable conversion activation trigger : Software, or reload timer (rising edge)

(1) Register list

ADCS1, ADCS0 (Control status register)										
ADCS0	bit	7	6	5	4	3	2	1	0	Initial Value
Address : 000034 _H		MD1	MD0	—	—	—	—	—	—	00 - - - - - B
		R/W	R/W	—	—	—	—	—	—	Read/Write
ADCS1									Initial Value	
bit	15	14	13	12	11	10	9	8	00000000 _B	
Address : 000035 _H	BUSY	INT	INTE	PAUS	STS1	STS0	STRT	Reserved	Read/Write	
	R/W	R/W	R/W	R/W	R/W	R/W	W	R/W		
ADCR1, ADCR0 (Data register)										
ADCR0	bit	7	6	5	4	3	2	1	0	Initial Value
Address : 000036 _H		D7	D6	D5	D4	D3	D2	D1	D0	XXXXXXXX _B
		R	R	R	R	R	R	R	R	Read/Write
ADCR1	bit	15	14	13	12	11	10	9	8	Initial Value
Address : 000037 _H		S10	ST1	ST0	CT1	CT0	—	D9	D8	00101 - XX _B
		W	W	W	W	W	—	R	R	Read/Write
- : Unused										

(2) Block Diagram

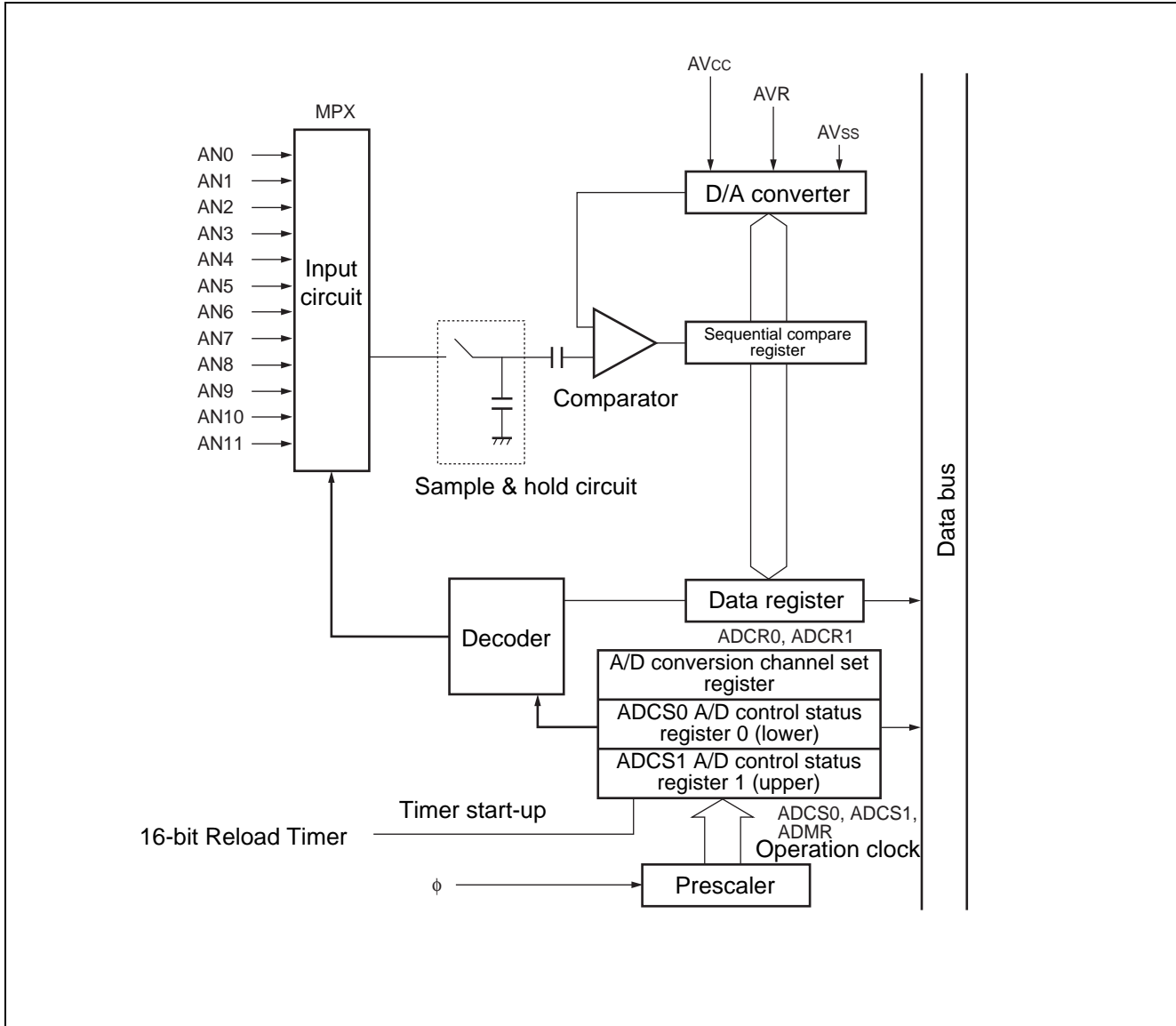

6. 16 bits PPG

The PPG timer consists of the following:

- Prescaler
- 16-bit down-counter: 1
- 16-bit data register with a cycle setting buffer
- 16-bit compare register with a duty setting buffer
- Pin control unit

The PPG timer can output pulses synchronized to the software trigger.

The output pulse can be changed to any cycle and duty freely by updating the PCSRL, PCSRH/PDUTL, PDUTH registers.

- PWM function

The PPG timer can output pulses programmably by updating the PCSR and PDUT registers described above in synchronization to the trigger.

Can also be used as a D/A converter by an external circuit.

- Single shot function

By detecting an edge of the trigger input, a single pulse can be output.

- 16-bit down counter

The counter operation clock comes from eight kinds optional. There are eight kinds of internal clocks.

(ϕ , $\phi/2$, $\phi/4$, $\phi/8$, $\phi/16$, $\phi/32$, $\phi/64$, $\phi/128$) ϕ : machine clock

The counter can be initialized to "FFFF_H" at a reset or counter borrow.

- Interrupt request

The PPG timer generates an interrupt request when :

- Timer start-up
- Counter borrow occurrence (cycle match)
- Duty match occurrence

MB90800 Series

(1) Register list

PCNTH (PCNTH0/PCNTH1 PPG Control Status register)

000077 _H	bit	15	14	13	12	11	10	9	8	Initial Value
00007F _H		CNTE	STGR	MDSE	RTRG	CKS2	CKS1	CKS0	PGMS	0000000 _B
		R/W	R/W	R/W	R/W	R/W	R/W	R/W	R/W	Read/Write

PCNTL (PCNTL0/PCNTL1 PPG Control Status register)

000076 _H	bit	7	6	5	4	3	2	1	0	Initial Value
00007E _H		—	—	IREN	IRQF	IRS1	IRS0	POEN	OSEL	- - 000000 _B
		—	—	R/W	R/W	R/W	R/W	R/W	R/W	Read/Write

PDCRH (PDCRH0/PDCRH1 PPG Down Counter Register)

000071 _H	bit	15	14	13	12	11	10	9	8	Initial Value
000079 _H		DC15	DC14	DC13	DC12	DC11	DC10	DC09	DC08	11111111 _B
		R	R	R	R	R	R	R	R	Read/Write

PDCRL (PDCRL0/PDCRL1 PPG Down Counter Register)

000070 _H	bit	7	6	5	4	3	2	1	0	Initial Value
000078 _H		DC07	DC06	DC05	DC04	DC03	DC02	DC01	DC00	11111111 _B
		R	R	R	R	R	R	R	R	Read/Write

PCSRH (PCSRH0/PCSRH1 PPG cycle set register)

000073 _H	bit	15	14	13	12	11	10	9	8	Initial Value
00007B _H		CS15	CS14	CS13	CS12	CS11	CS10	CS09	CS08	XXXXXXXX _B
		W	W	W	W	W	W	W	W	Read/Write

PCSRL (PCSRL0/PCSRL1 PPG cycle set register)

000072 _H	bit	7	6	5	4	3	2	1	0	Initial Value
00007A _H		CS07	CS06	CS05	CS04	CS03	CS02	CS01	CS00	XXXXXXXX _B
		W	W	W	W	W	W	W	W	Read/Write

PDUTH (PDUTH0/PDUTH1 PPG duty set register)

000075 _H	bit	15	14	13	12	11	10	9	8	Initial Value
00007D _H		DU15	DU14	DU13	DU12	DU11	DU10	DU09	DU08	XXXXXXXX _B
		W	W	W	W	W	W	W	W	Read/Write

PDUTL (PDUTL0/PDUTL1 PPG duty set register)

000074 _H	bit	7	6	5	4	3	2	1	0	Initial Value
00007C _H		DU07	DU06	DU05	DU04	DU03	DU02	DU01	DU00	XXXXXXXX _B
		W	W	W	W	W	W	W	W	Read/Write

- : Unused

(2) Block Diagram

- 16-bit PPG ch.0/ch.1 block diagram

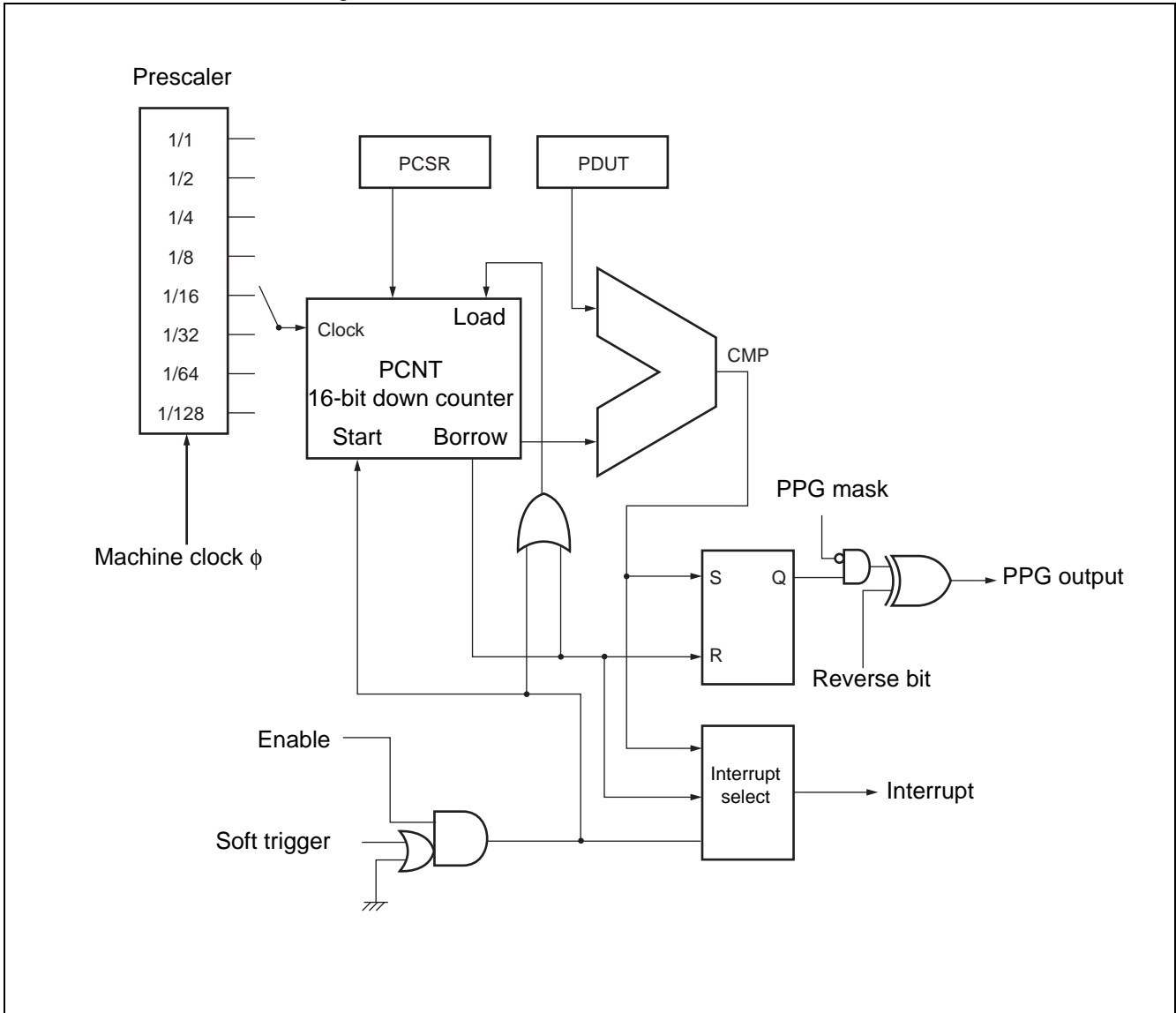

7. Delay interrupt generator module

The delayed interrupt generation module outputs an interrupt request for task switching. The hardware interrupt request can be generated by software.

(1) Register list

Delayed Interrupt/release register(DIRR)									Initial Value	
DIRR	bit	15	14	13	12	11	10	9	8	
Address : 00009FH		—	—	—	—	—	—	—	R0	----- 0 _B
		—	—	—	—	—	—	—	R/W	Read/Write

- : Unused

(2) Block diagram

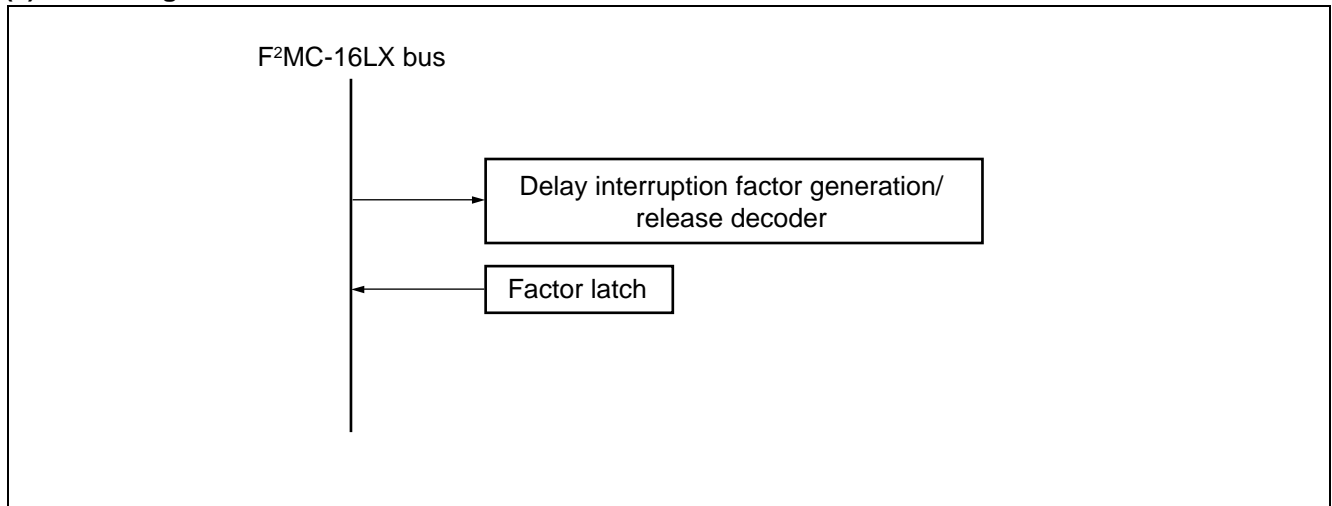

8. DTP/External interrupt

DTP (Data Transfer Peripheral)/External interrupt circuit detects the interrupt request input from the external interrupt input terminal, and outputs the interrupt request.

(1) Register list

Interrupt/DTP enable register (ENIR)								Initial Value		
ENIR	bit	7	6	5	4	3	2	1	0	----- 0000 _B
Address : 000030 _H		—	—	—	—	EN3	EN2	EN1	EN0	Read/Write
		—	—	—	—	R/W	R/W	R/W	R/W	
Interrupt/DTP source register (EIRR)								Initial Value		
EIRR	bit	15	14	13	12	11	10	9	8	----- XXXX _B
Address : 000031 _H		—	—	—	—	ER3	ER2	ER1	ER0	Read/Write
		—	—	—	—	R/W	R/W	R/W	R/W	
Request level setting register (ELVR)								Initial Value		
ELVR	bit	7	6	5	4	3	2	1	0	00000000 _B
Address : 000032 _H		LB3	LA3	LB2	LA2	LB1	LA1	LB0	LA0	Read/Write
		R/W	R/W	R/W	R/W	R/W	R/W	R/W	R/W	
- : Unused										

(2) Block diagram

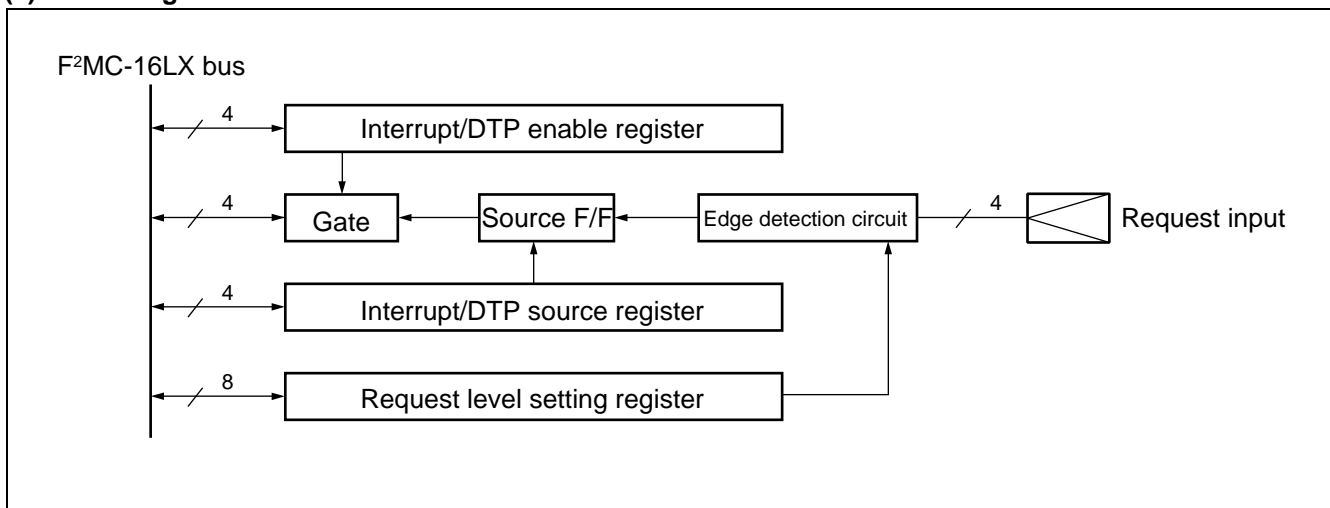

9. 16-bit input/output timer

The 16-bit I/O timer consists of one 16-bit free-run timer, two output compare and two input capture. This function enables six independent waveforms to be output based on the 16-bit free-run timer, and input pulse widths and external clock frequencies to be measured.

• Register list

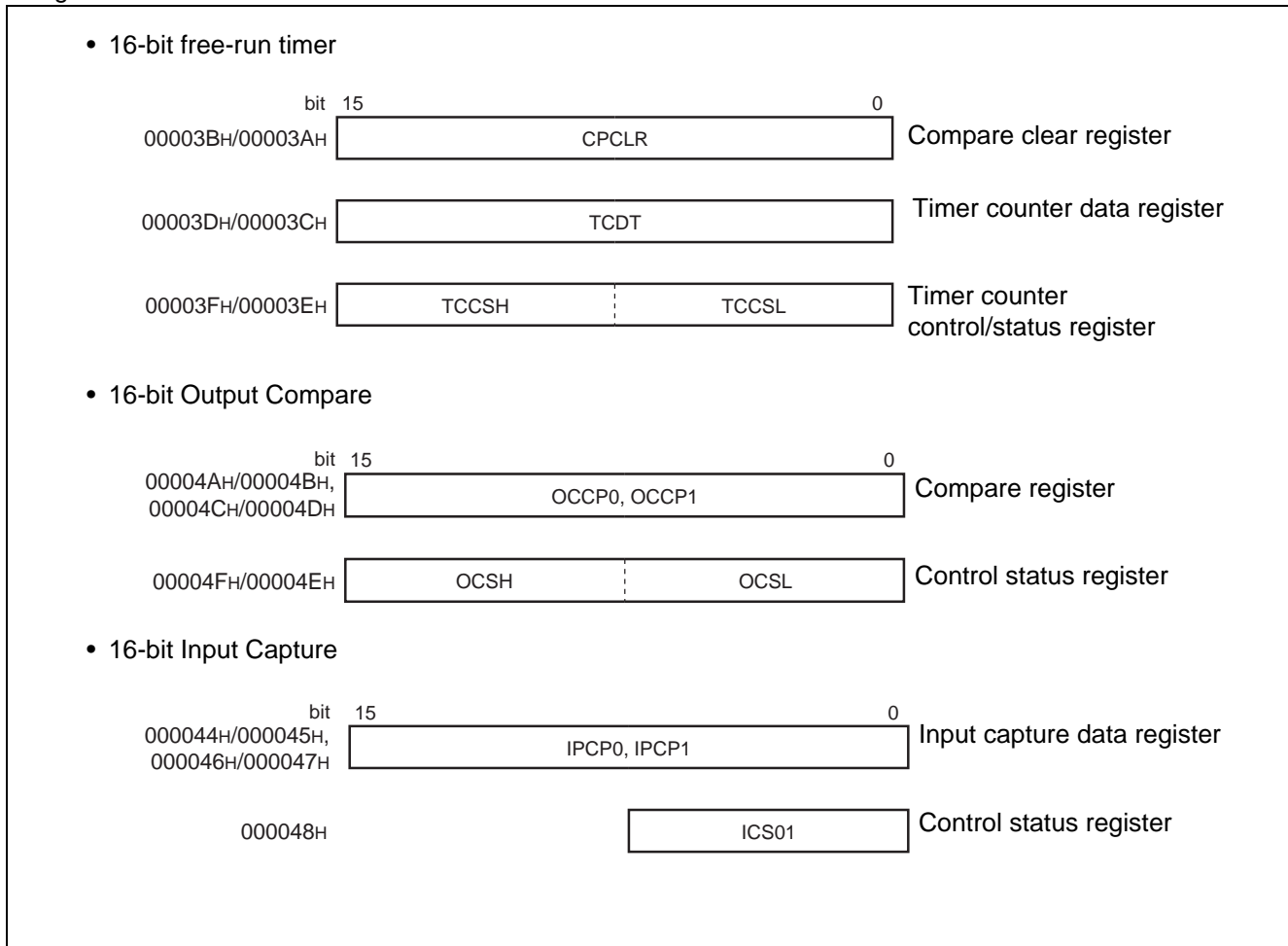

• Block diagram

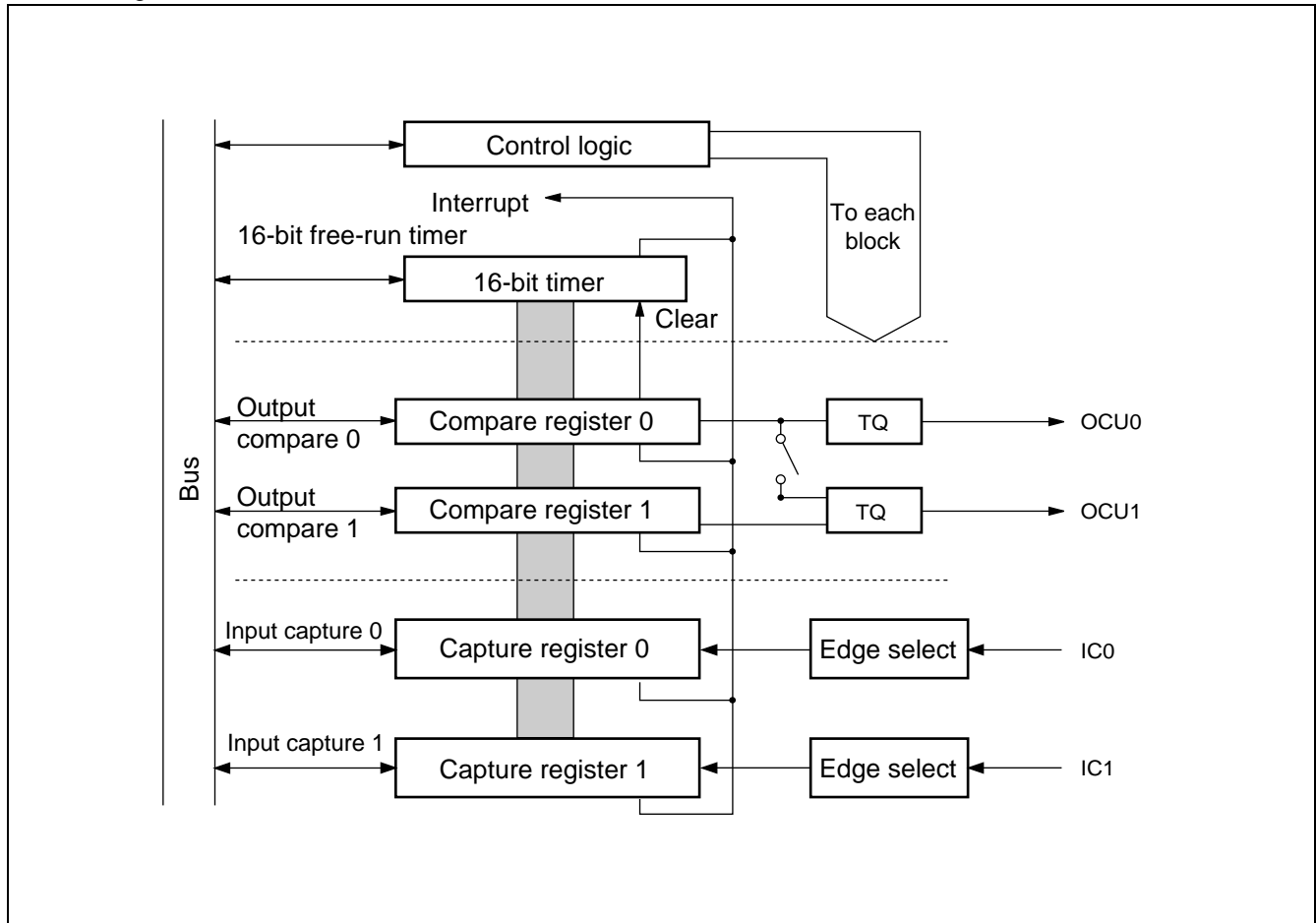

(1) 16-bit free-run timer

The 16-bit free-run timer consists of a 16-bit up-down counter and control status register.

Counter value of 16-bit free-run timer is available as base timer for input capture and output compare.

- Clock for the counter operation can be selected from eight types.
- The counter overflow interruption can be generated.
- Setting the mode enables initialization of the counter through compare-match operation with the value of the compare clear register in the output compare and that of the free-run timer counter.

• Register list

Compare clear register (CPCLR)								Initial Value	
bit	15	14	13	12	11	10	9	8	XXXXXXXX _B
00003B _H	CL15	CL14	CL13	CL12	CL11	CL10	CL09	CL08	Read/Write
	R/W	R/W	R/W	R/W	R/W	R/W	R/W	R/W	
Compare clear register (CPCLR)								Initial Value	
bit	7	6	5	4	3	2	1	0	XXXXXXXX _B
00003A _H	CL07	CL06	CL05	CL04	CL03	CL02	CL01	CL00	Read/Write
	R/W	R/W	R/W	R/W	R/W	R/W	R/W	R/W	
Timer counter data register (TCDT)								Initial Value	
bit	15	14	13	12	11	10	9	8	00000000 _B
00003D _H	T15	T14	T13	T12	T11	T10	T09	T08	Read/Write
	R/W	R/W	R/W	R/W	R/W	R/W	R/W	R/W	
Timer counter data register (TCDT)								Initial Value	
bit	7	6	5	4	3	2	1	0	00000000 _B
00003C _H	T07	T06	T05	T04	T03	T02	T01	T00	Read/Write
	R/W	R/W	R/W	R/W	R/W	R/W	R/W	R/W	
Timer counter control/status register (TCCS)								Initial Value	
bit	15	14	13	12	11	10	9	8	0--00000 _B
00003F _H	ECKE	—	—	MSI2	MSI1	MSI0	ICLR	ICRE	Read/Write
	R/W	—	—	R/W	R/W	R/W	R/W	R/W	
Timer counter control/status register (TCCS)								Initial Value	
bit	7	6	5	4	3	2	1	0	00000000 _B
00003E _H	IVF	IVFE	STOP	MODE	SCLR	CLK2	CLK1	CLK0	Read/Write
	R/W	R/W	R/W	R/W	R/W	R/W	R/W	R/W	
- : Unused									

• Block diagram

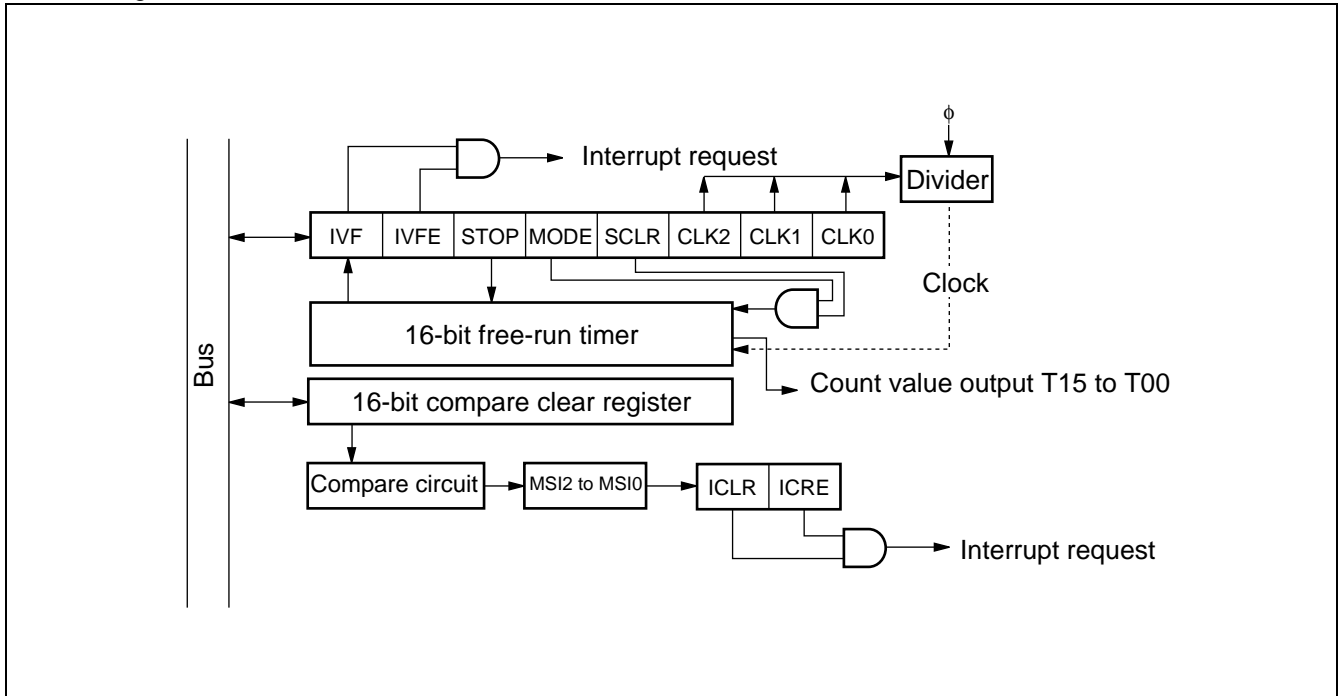

MB90800 Series

(2) Output compare

The output compare consists of 16-bit compare registers, compare output pin part and a control register. It can reverse the output level for the pin and at the same time, generate an interrupt when the 16-bit free-run timer value matches a value set in one of the 16-bit compare registers of this module.

- It has a total of six compare registers that can operate independently. In addition, the output can be set to be controlled by using two compare registers.
- An interrupt can be set by a comparing match.

• Register list

Compare register (OCCP0, OCCP1)								Initial Value	
bit	15	14	13	12	11	10	9	8	00000000 _B
00004B _H	OP15	OP14	OP13	OP12	OP11	OP10	OP09	OP08	
00004D _H	R/W	R/W	R/W	R/W	R/W	R/W	R/W	R/W	Read/Write
Compare register (OCCP2, OCCP3)								Initial Value	
bit	7	6	5	4	3	2	1	0	00000000 _B
00004A _H	OP07	OP06	OP05	OP04	OP03	OP02	OP01	C00	
00004C _H	R/W	R/W	R/W	R/W	R/W	R/W	R/W	R/W	Read/Write
Control register (OCSH)								Initial Value	
bit	15	14	13	12	11	10	9	8	---0000 _B
00004F _H	—	—	—	CMOD	OTE1	OTE0	OTD1	OTD0	
	—	—	—	R/W	R/W	R/W	R/W	R/W	Read/Write
Control register (OCSL)								Initial Value	
bit	7	6	5	4	3	2	1	0	0000--00 _B
00004E _H	IOP1	IOP0	IOE1	IOE0	—	—	CST1	CST0	
	R/W	R/W	R/W	R/W	—	—	R/W	R/W	Read/Write
- : Unused									

• Block diagram

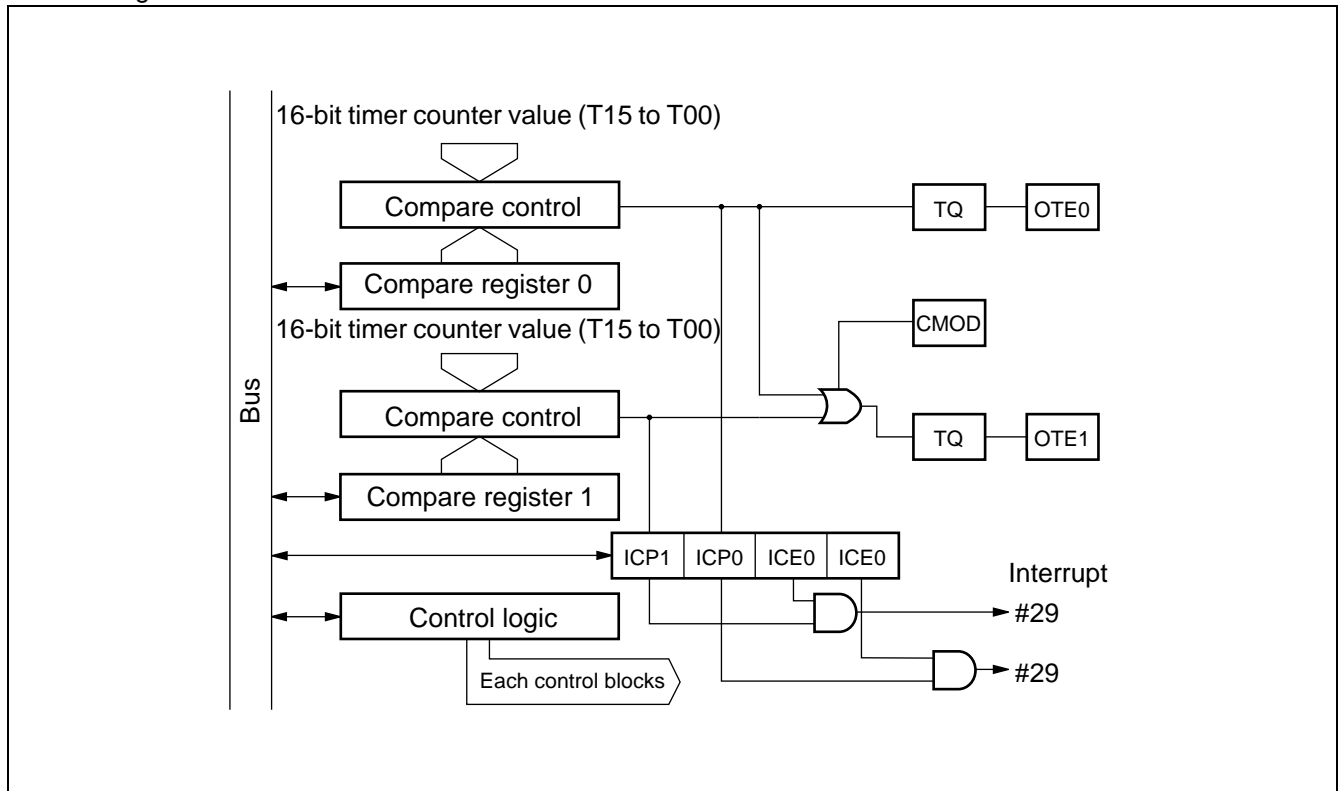

(3) Input capture

The input capture consists of input capture and control registers. Each input capture has its corresponding external input pin.

This module has a function that detects a rising edge, falling edge or both edges and holds a value of the 16-bit free-run timer in a register at the time of detection. It can also generate an interrupt when detecting an edge.

- The detection edge of an external input can be selected from among three types. Rising edge/falling edge/both edges.
- It can generate an interrupt when it detects the valid edge of the external input.

• Register list

Input capture data register (IPCP0, IPCP1)										Initial Value
000045H	bit	15	14	13	12	11	10	9	8	XXXXXXXX _B
000047H		CP15	CP14	CP13	CP12	CP11	CP10	CP09	CP08	Read/Write
		R	R	R	R	R	R	R	R	
Input capture data register (IPCP0, IPCP1)										Initial Value
000044H	bit	7	6	5	4	3	2	1	0	XXXXXXXX _B
000046H		CP07	CP06	CP05	CP04	CP03	CP02	CP01	CP00	Read/Write
		R	R	R	R	R	R	R	R	
Control status register (ICS01)										Initial Value
000048H	bit	7	6	5	4	3	2	1	0	00000000 _B
		ICP1	ICP0	ICE1	ICE0	EG11	EG10	EG01	EG00	Read/Write
		R/W	R/W	R/W	R/W	R/W	R/W	R/W	R/W	

• Block diagram

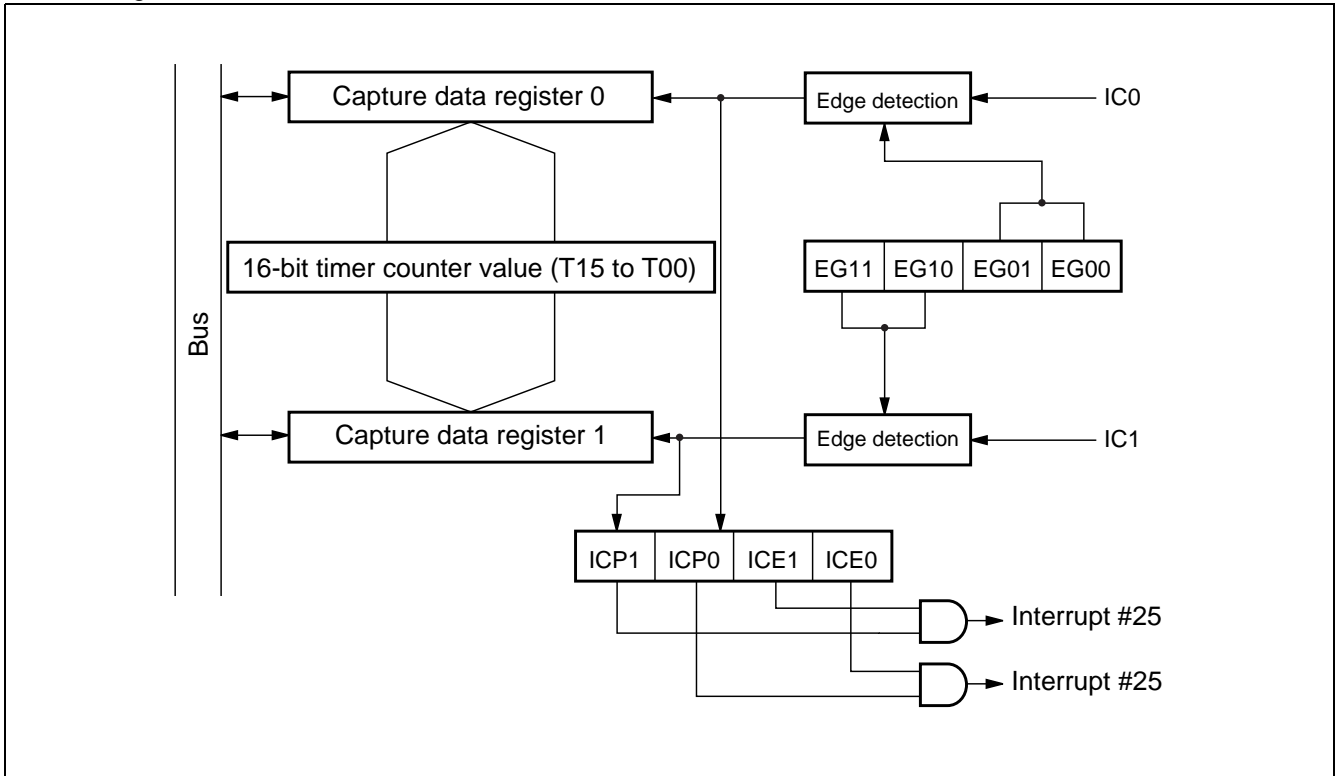

10. 16-bit reload timer

The 16-bit reload timer provides two functions either one which can be selected, the internal clock mode that performs the count down by synchronizing with 3-type internal clocks and the event count mode that performs the count down by detecting the arbitration. This timer defines an underflow as a transition of the count value from 0000H to FFFFH. Therefore, when the equation (counted value = reload register setting value+1) holds, an underflow occurs. Either mode can be selected for the count operation from the reload mode which repeats the count by reloading the count setting value at the underflow occurrence or the one-shot mode which stops the count at the underflow occurrence. The interrupt can be generated at the counter underflow occurrence so as to correspond to the DTC.

(1) Register list

- TMCSR Timer control status register

Timer control status register (upper) (TMCSR0H to TMCSR2H)

bit	15	14	13	12	11	10	9	8	Initial Value
000051H	—	—	—	—	CSL1	CSL0	MOD2	MOD1	---- 0000 _B
000055H					R/W	R/W	R/W	R/W	Read/Write
000059H	—	—	—	—					

Timer control status register (lower) (TMCSR0L to TMCSR2L)

bit	7	6	5	4	3	2	1	0	Initial Value
000050H	MOD0	OUTE	OUTL	RELD	INTE	UF	CNTE	TRG	00000000 _B
000054H	R/W	R/W	R/W	R/W	R/W	R/W	R/W	R/W	Read/Write
000058H									

- 16-bit timer register/16-bit reload register TMR0 to TMR2/TMRLR0 to TMRLR2 (upper)

bit	15	14	13	12	11	10	9	8	Initial Value
000053H	D15	D14	D13	D12	D11	D10	D9	D8	XXXXXXXX _B
000057H	R/W	R/W	R/W	R/W	R/W	R/W	R/W	R/W	Read/Write
00005BH									

TMR0 to TMR2/TMRLR0 to TMRLR2 (lower)

bit	7	6	5	4	3	2	1	0	Initial Value
000052H	D7	D6	D5	D4	D3	D2	D1	D0	XXXXXXXX _B
000056H	R/W	R/W	R/W	R/W	R/W	R/W	R/W	R/W	Read/Write
00005AH									

- : Unused

(2) Block diagram

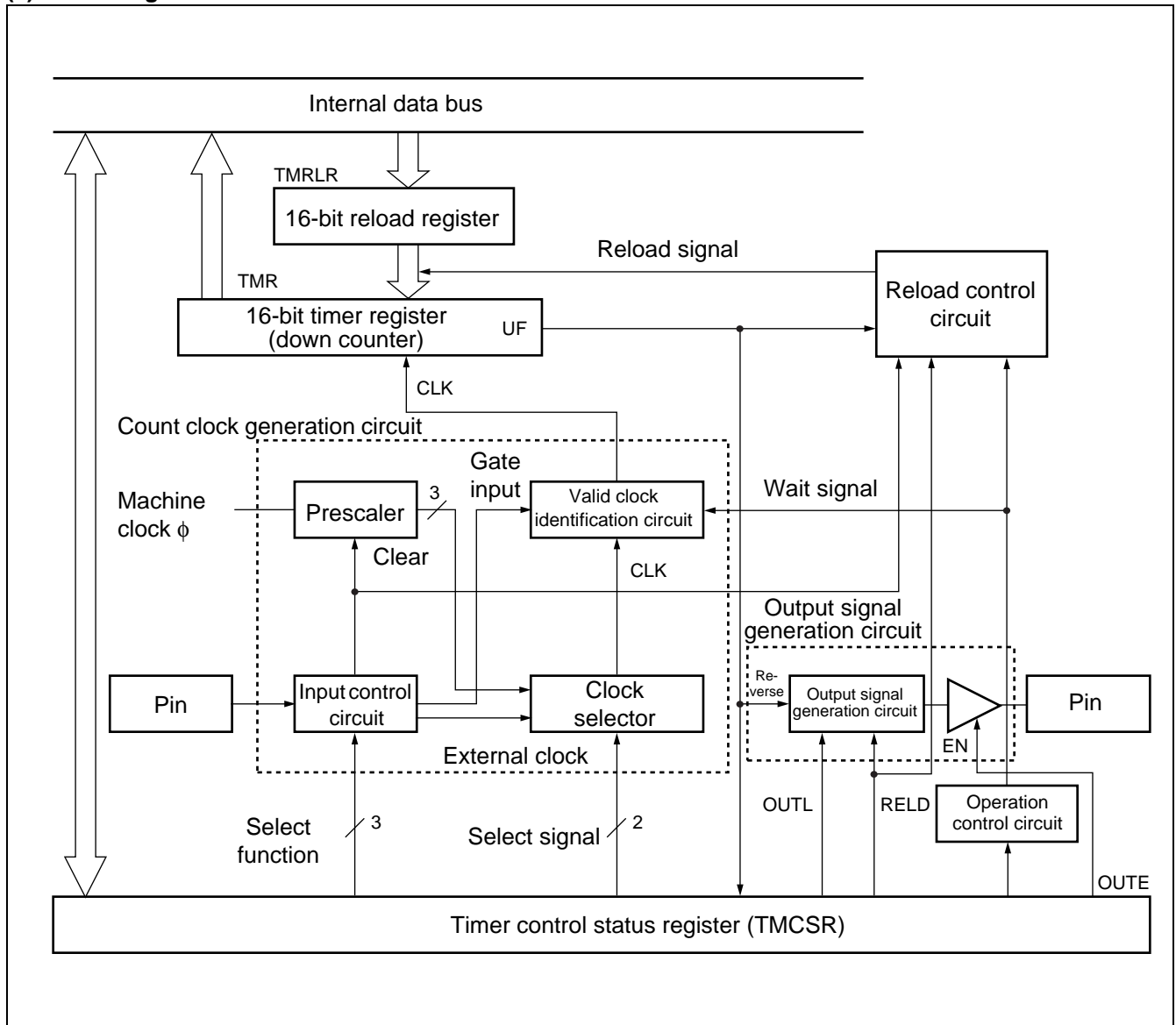

MB90800 Series

11. Watch timer

The watch timer is a 15-bit timer using the subclock. It can generate the interrupt request for each interval time. The watch timer can also be used as the clock source of the watchdog timer by setting so.

(1) Register list

Watch timer control register (WTC)								Initial Value	
bit	7	6	5	4	3	2	1	0	
0000AA _H	WDCS	SCE	WTIE	WTOF	WTR	WTC2	WTC1	WTC0	1X011000 _B
	R/W	R	R/W	R/W	R/W	R/W	R/W	R/W	Read/Write

(2) Block diagram

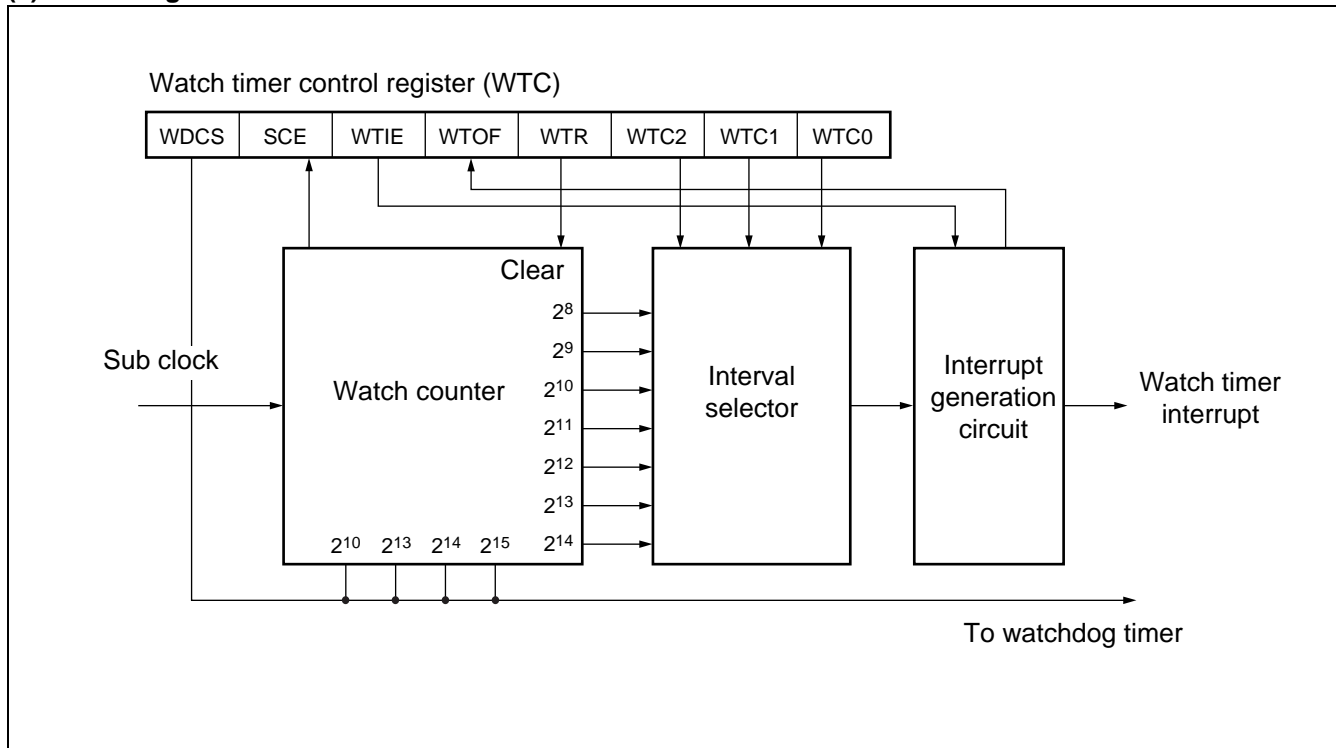

12. Watchdog timer

The watchdog timer is a timer counter provided for preventing program malfunction. The watchdog timer is a 2-bit counter operating with an output of the timebase timer or watch timer as count clock and resets the CPU when the counter is not cleared within the interval time.

(1) Register list

Watchdog timer control register (WDTC)								Initial Value	
bit	7	6	5	4	3	2	1	0	XXXXX111 _B
0000A8 _H	PONR	—	WRST	ERST	SRST	WTE	WT1	WT0	Read/Write
	R	—	R	R	R	W	W	W	

— : Unused

(2) Block diagram

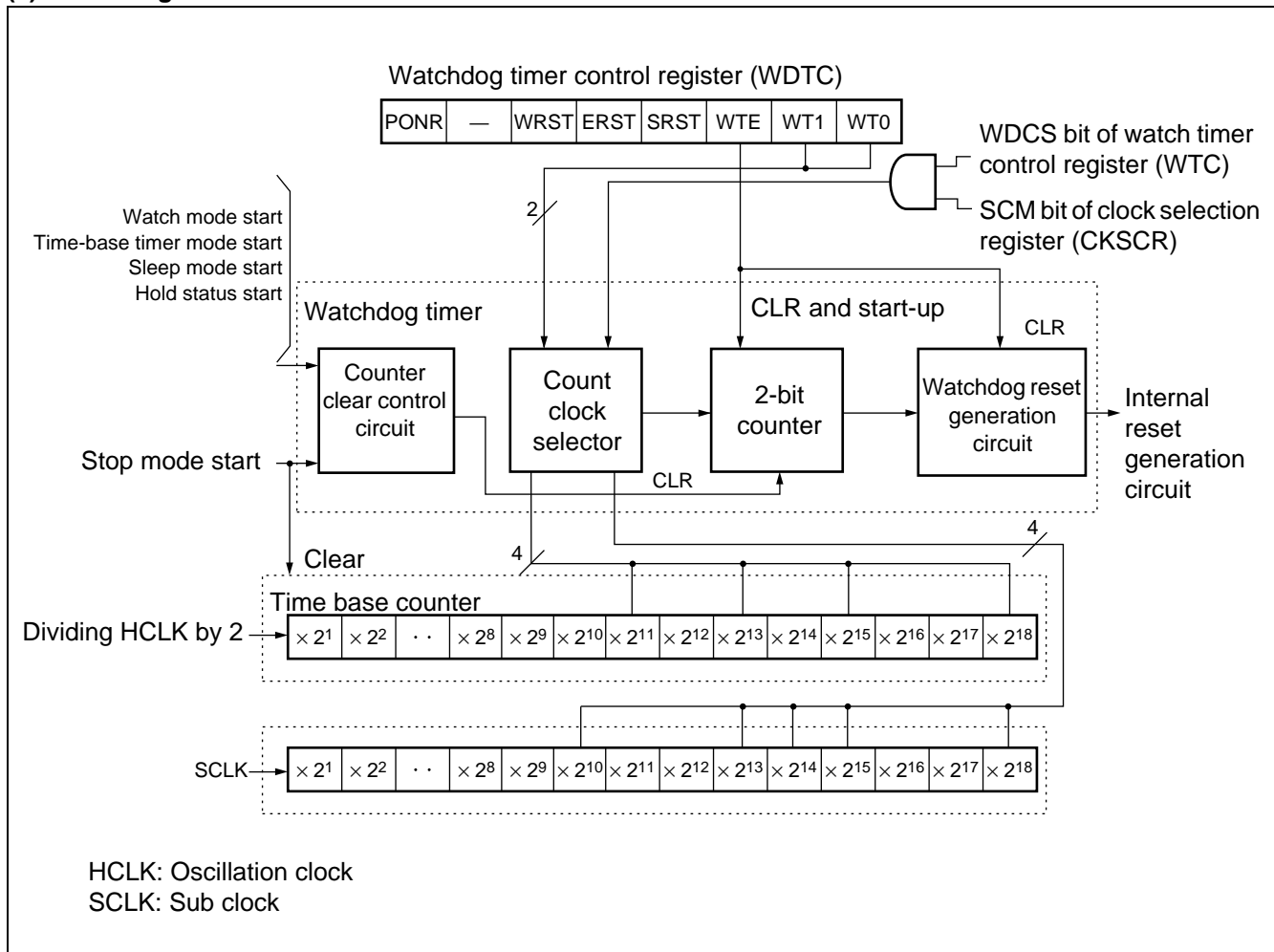

MB90800 Series

13. Time-base timer

The time-base timer has a function that enables a selection of four interval times using 18-bit free-run counter (time-base counter) with synchronizing to the internal count clock (two division of original oscillation). Furthermore, the function of timer output of oscillation stabilization wait or function supplying operation clocks for watchdog timer are provided.

(1) Register list

Time-base timer control register (TBTC)								Initial Value	
bit	15	14	13	12	11	10	9	8	
0000A9H	Reserved	—	—	TBIE	TBOF	TBR	TBC1	TBC0	1 - - 00100B
	R/W	—	—	R/W	R/W	W	R/W	R/W	Read/Write

- : Unused

(2) Block diagram

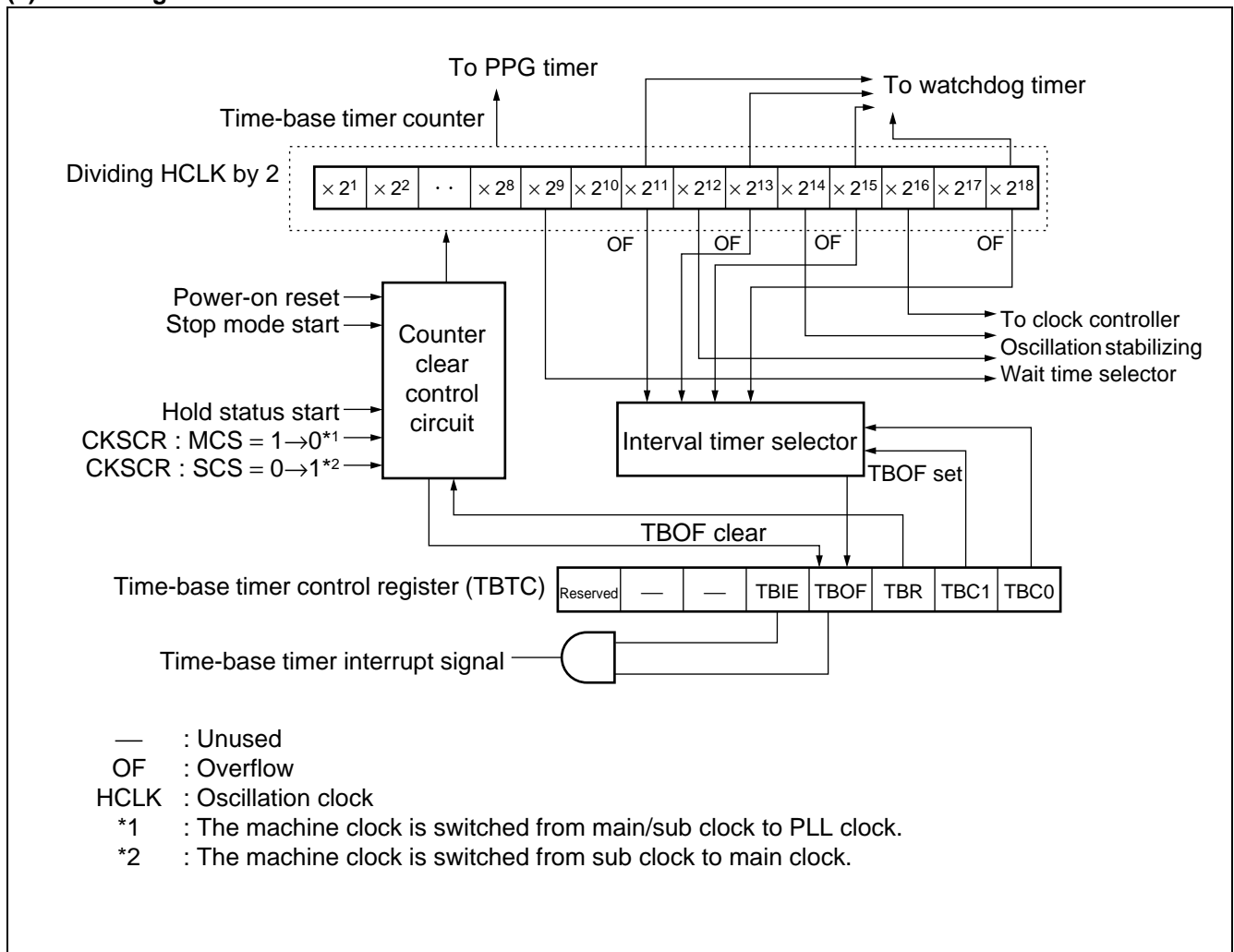

14. Clock generator

The clock generator controls operation of the internal clock which is the operation clock for the CPU and peripheral devices. This internal clock is used as machine clock and its one cycle as machine cycle. In addition, the clock generated by original oscillation is used as oscillation clock and that by internal PLL oscillation as PLL clock.

(1) Register list

Clock selection register (CKSCR)								Initial Value	
bit	15	14	13	12	11	10	9	8	
0000A1 _H	SCM	MCM	WS1	WS0	SCS	MCS	CS1	CS0	11111100 _B
	R	R	R/W	R/W	R/W	R/W	R/W	R/W	Read/Write

MB90800 Series

(2) Block diagram

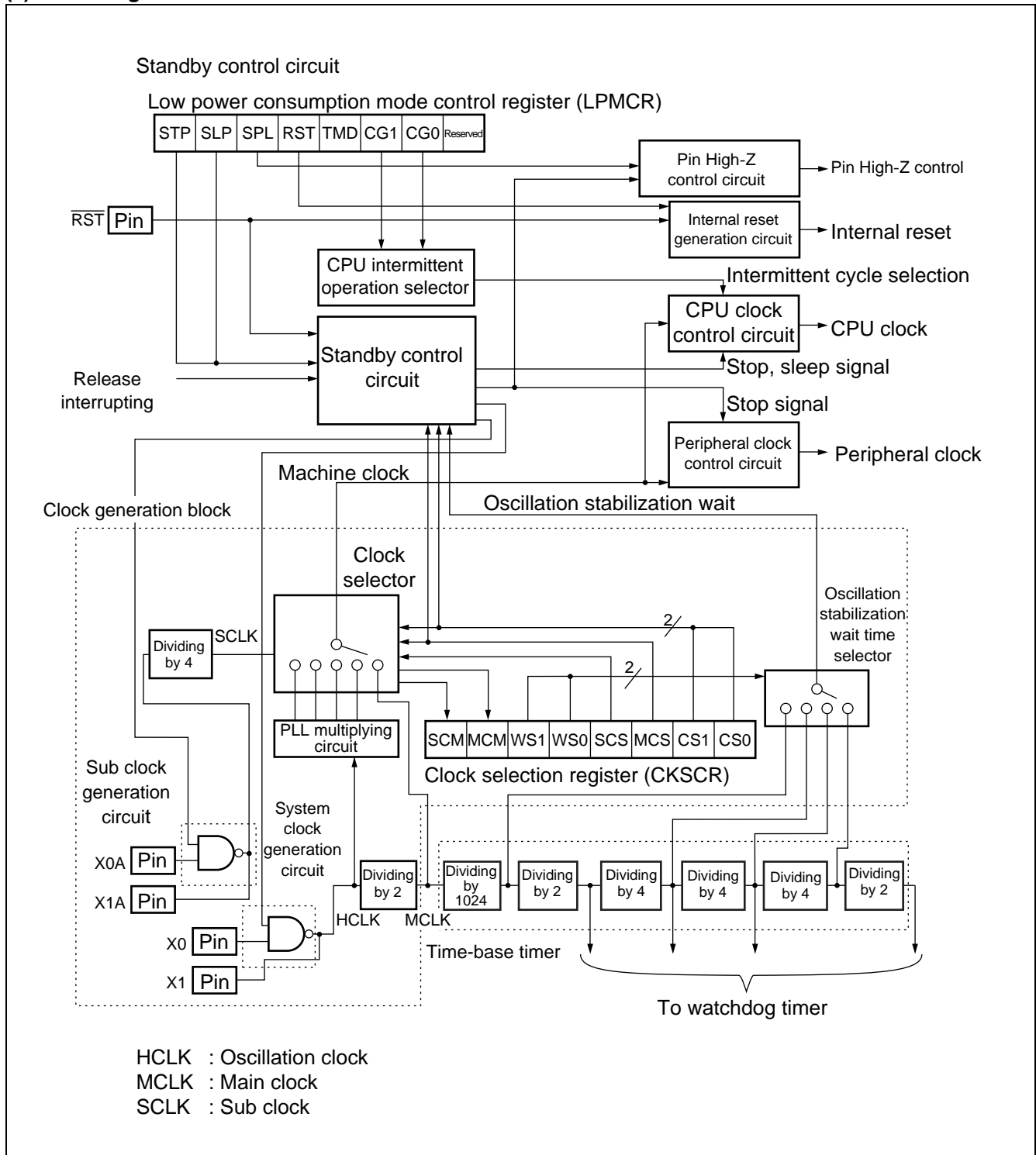

(3) Clock supply map

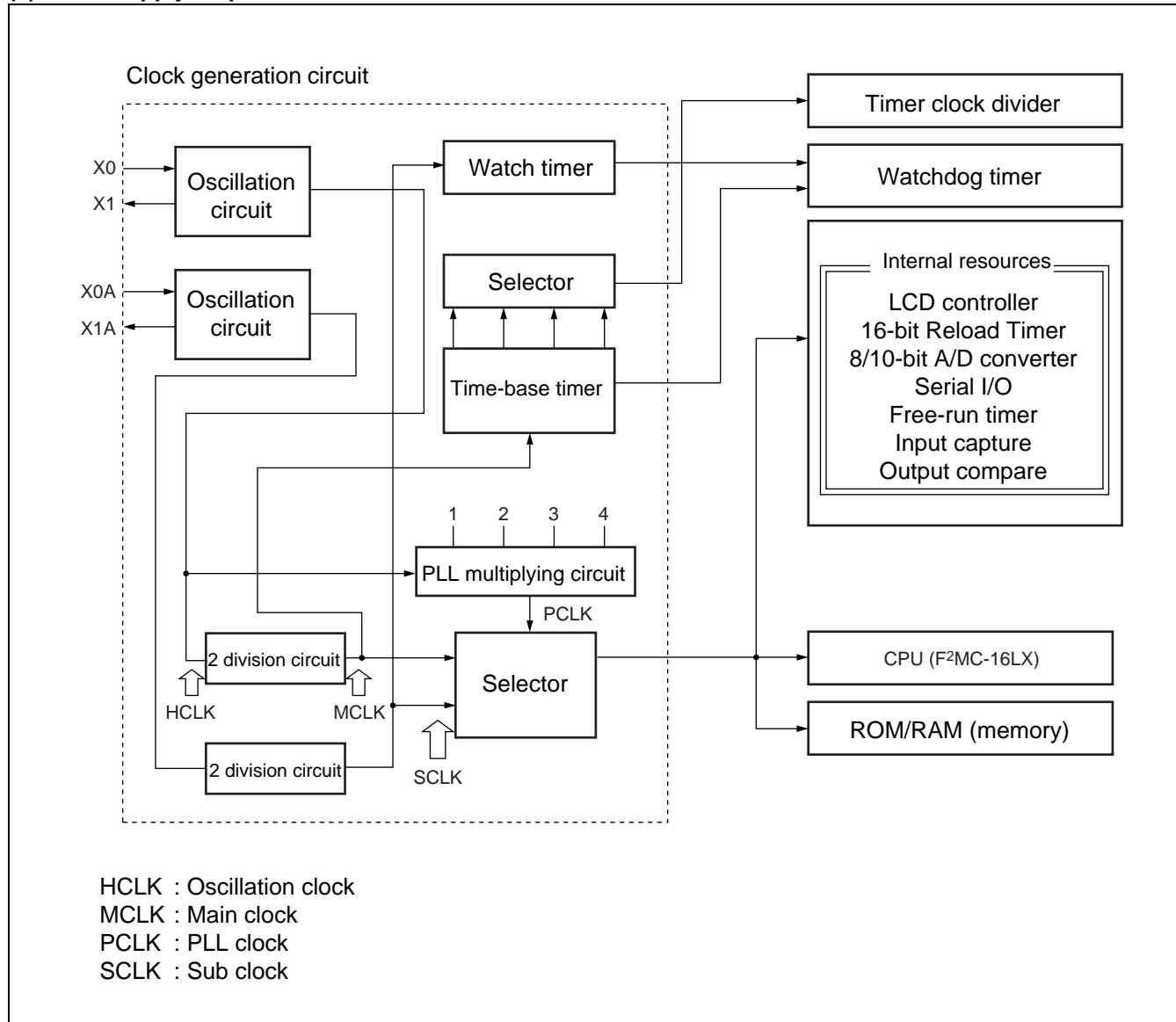

15. Low power consumption mode

The low-power consumption mode has the following CPU operation modes by selecting the operation clock and operating the control of the clock.

- Clock mode
(PLL clock mode, main clock mode and sub clock mode)
- CPU intermittent operation mode
(PLL clock intermittent operation mode, main clock intermittent operation mode and subclock intermittent operation mode)
- Standby mode
(Sleep mode, time base timer mode, stop mode and watch mode)

(1) Register list

Low power consumption mode control register (LPMCR)									Initial Value
bit	7	6	5	4	3	2	1	0	
0000A0 _H	STP	SLP	SPL	RST	TMD	CG1	CG0	Reserved	00011000 _B
	W	W	R/W	W	R/W	R/W	R/W	R/W	Read/Write

(2) Block diagram

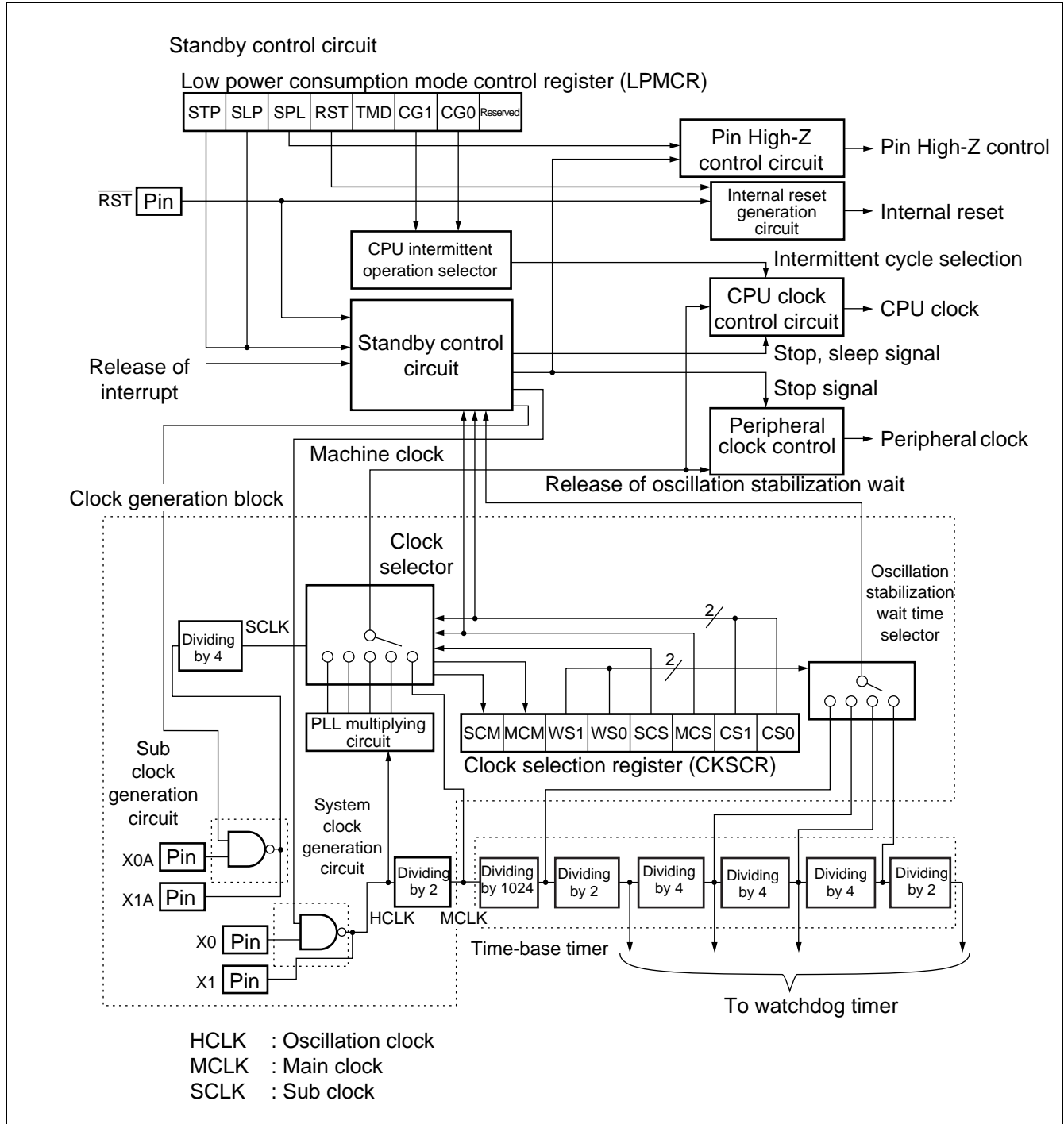

(3) Figure of status transition

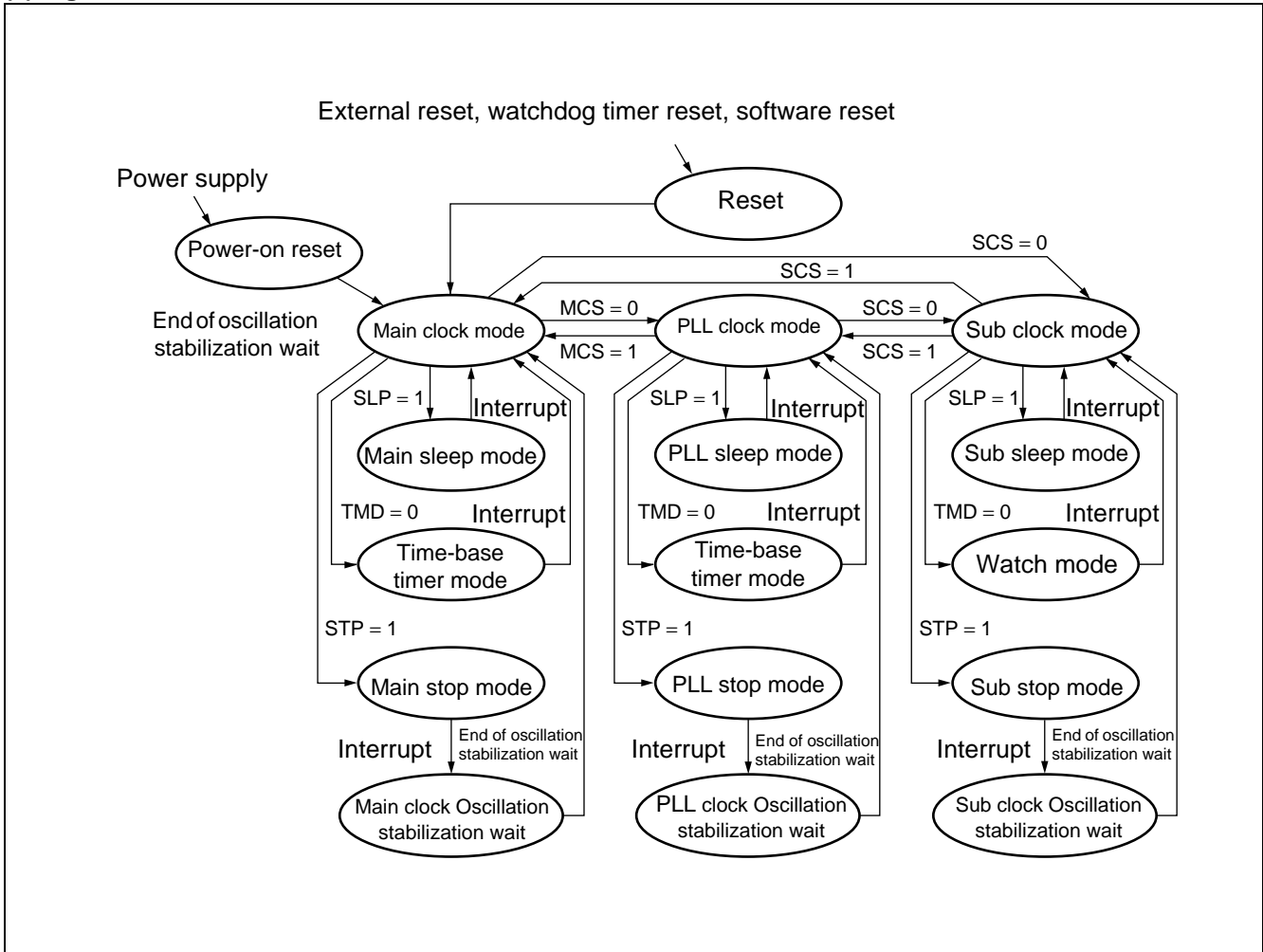

16. Timer clock output

The timer clock output circuit divides the oscillation clock by the time-base timer and generates and outputs the set division clock. Selectable from 32/64/128/256 division of the oscillation clock.

The timer clock output circuit is inactive in reset or stop mode. It is active in normal run, sleep, or pseudo-timer mode.

	PLL_Run	Main_Run	Sleep	Pseudo clock	STOP	Reset
Operation status	○	○	○	○	×	×

Note : When the time-base timer is cleared while using the timer clock output circuit, the clock is not correctly output. For detail of the time-base timer's clear condition, see the section of time-base timer in the MB90800 Hardware Manual.

(1) Register list

Watch clock output control register (TMCS)								Initial Value
bit 0000AF _H								XXXXX000 _B
15	14	13	12	11	10	9	8	
—	—	—	—	—	TEN	TS1	TS0	
—	—	—	—	—	R/W	R/W	R/W	Read/Write

- : Unused

(2) Block diagram

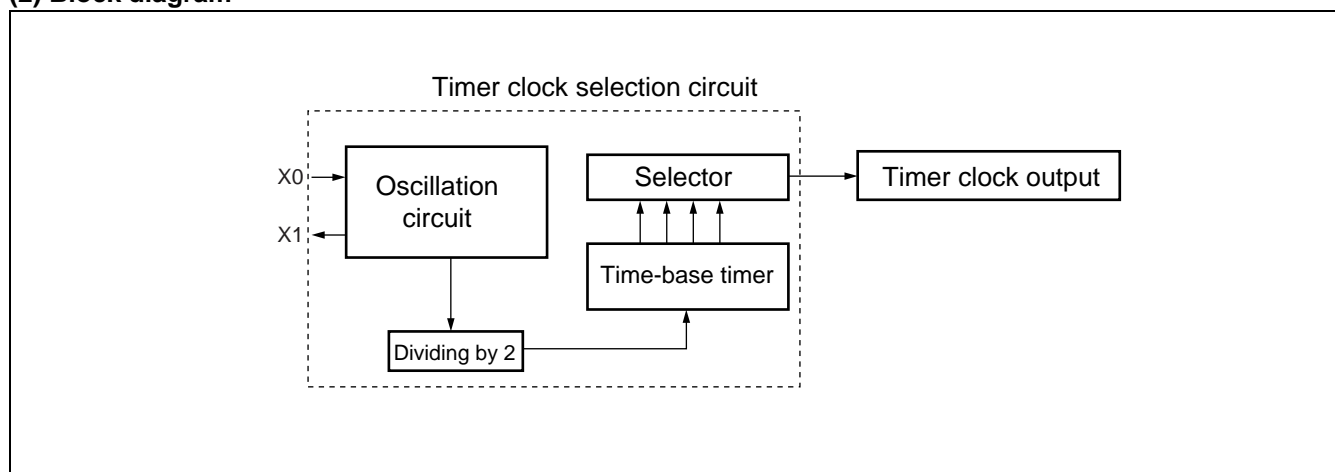

17. ROM mirroring function selection module

ROM mirroring function selection module provides the setting so that ROM data located in FF bank can be read by access to 00 bank.

(1) Register list

ROM mirror function select register (ROMM)								Initial Value	
00006FH	bit 15	14	13	12	11	10	9	8	XXXXXXXX1 _B
	—	—	—	—	—	—	—	MI	
	—	—	—	—	—	—	—	R/W	Read/Write

- : Unused

(2) Block diagram

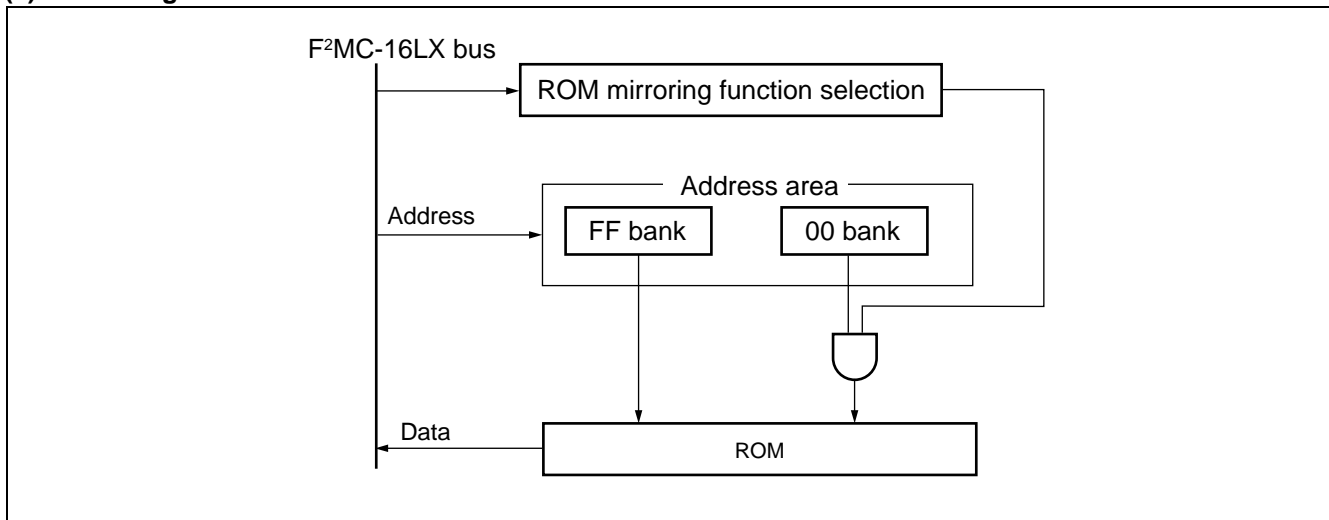

Note : Do not access to ROM mirroring function selection register in the middle of the operation of the address 008000_H to 00FFFF_H.

18. Interrupt controller

Interrupt control register is in the interrupt controller. The register corresponds to all I/O of interrupt function. The register has following functions;

- Setting of Interrupt level at correspondent peripheral circuit.

(1) Register list (at writing)

Interrupt control register		Initial Value
Address :		
ICR01 0000B1H		00000111B
ICR03 0000B3H		
ICR05 0000B5H		
ICR07 0000B7H		
ICR09 0000B9H		
ICR11 0000BBH		
ICR13 0000BDH		
ICR15 0000BFH		
	W W W W R/W R/W R/W R/W	Read/Write
Interrupt control register		Initial Value
Address :		
ICR00 0000B0H		00000111B
ICR02 0000B2H		
ICR04 0000B4H		
ICR06 0000B6H		
ICR08 0000B8H		
ICR10 0000BAH		
ICR12 0000BCH		
ICR14 0000BEH		
	W W W W R/W R/W R/W R/W	Read/Write
Note : Do not access using read modify write instruction because it causes the malfunction.		

MB90800 Series

(2) Register list (at reading)

Interrupt control register

Initial Value

Address :

ICR01 0000B1H
 ICR03 0000B3H
 ICR05 0000B5H
 ICR07 0000B7H
 ICR09 0000B9H
 ICR11 0000BBH
 ICR13 0000BDH
 ICR15 0000BFH

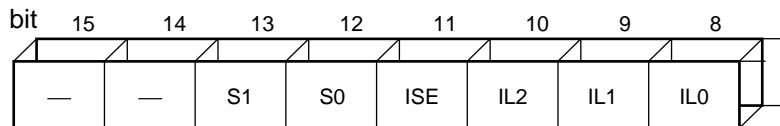

00000111B

Read/Write
 Initial Value

— — R R R/W R/W R/W R/W

Read/Write

Interrupt control register

Initial Value

Address :

ICR00 0000B0H
 ICR02 0000B2H
 ICR04 0000B4H
 ICR06 0000B6H
 ICR08 0000B8H
 ICR10 0000BAH
 ICR12 0000BCH
 ICR14 0000BEH

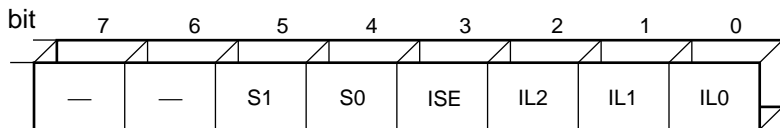

00000111B

Read/Write
 Initial Value

— — R R R/W R/W R/W R/W

Read/Write

- : Unused

Note : Do not access using read modify write instruction because it causes the malfunction.

(3) Block diagram

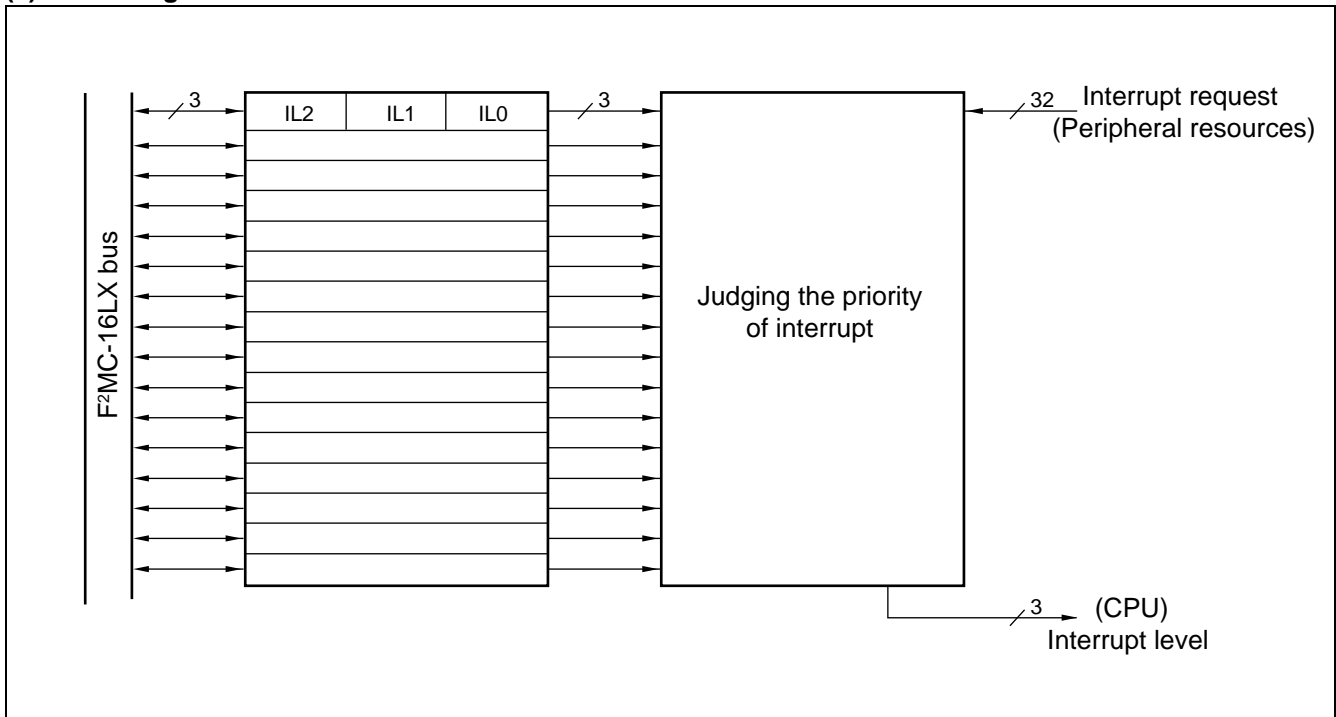

19. LCD controller/driver

The LCD controller/driver contains 24 × 8-bit display data memory and controls the LCD display with four common output lines and 48 segment output lines. Three duty outputs can be selected to directly drive the LCD panel (liquid crystal display).

- Contains an LCD driving voltage split resistor. Moreover, the external division resistance can be connected.
- A maximum of four common output lines (COM0 to COM3) and 48 segment output lines (SEG0 to SEG47) are available.
- Contains 24-byte display data memory (display RAM).
- For the duty, 1/2, 1/3, or 1/4 can be selected (restricted by bias setting).
- The LCD can directly be driven.

Bias	1/2 duty	1/3 duty	1/4 duty
1/2 bias	○	×	×
1/3 bias	×	○	○

○ : Recommended mode

× : Disable

(1) Register list

• LCDC control register (upper) (LCRH)									
bit	15	14	13	12	11	10	9	8	Initial Value
00005D _H	SS4	VS0	CS1	CS0	SS3	SS2	SS1	SS0	00000000 _B
	R/W	R/W	R/W	R/W	R/W	R/W	R/W	R/W	Read/Write
• LCDC control register (lower) (LCRL)									
bit	7	6	5	4	3	2	1	0	Initial Value
00005C _H	CSS	LCEN	VSEL	BK	MS1	MS0	FP1	FP0	00010000 _B
	R/W	R/W	R/W	R/W	R/W	R/W	R/W	R/W	Read/Write
• LCDC range register (LCRR)									
bit	7	6	5	4	3	2	1	0	Initial Value
00005E _H	Reserved	Reserved	SE4	SE3	SE2	SE1	SE0	LCR	00000000 _B
	R/W	R/W	R/W	R/W	R/W	R/W	R/W	R/W	Read/Write

(2) Block diagram

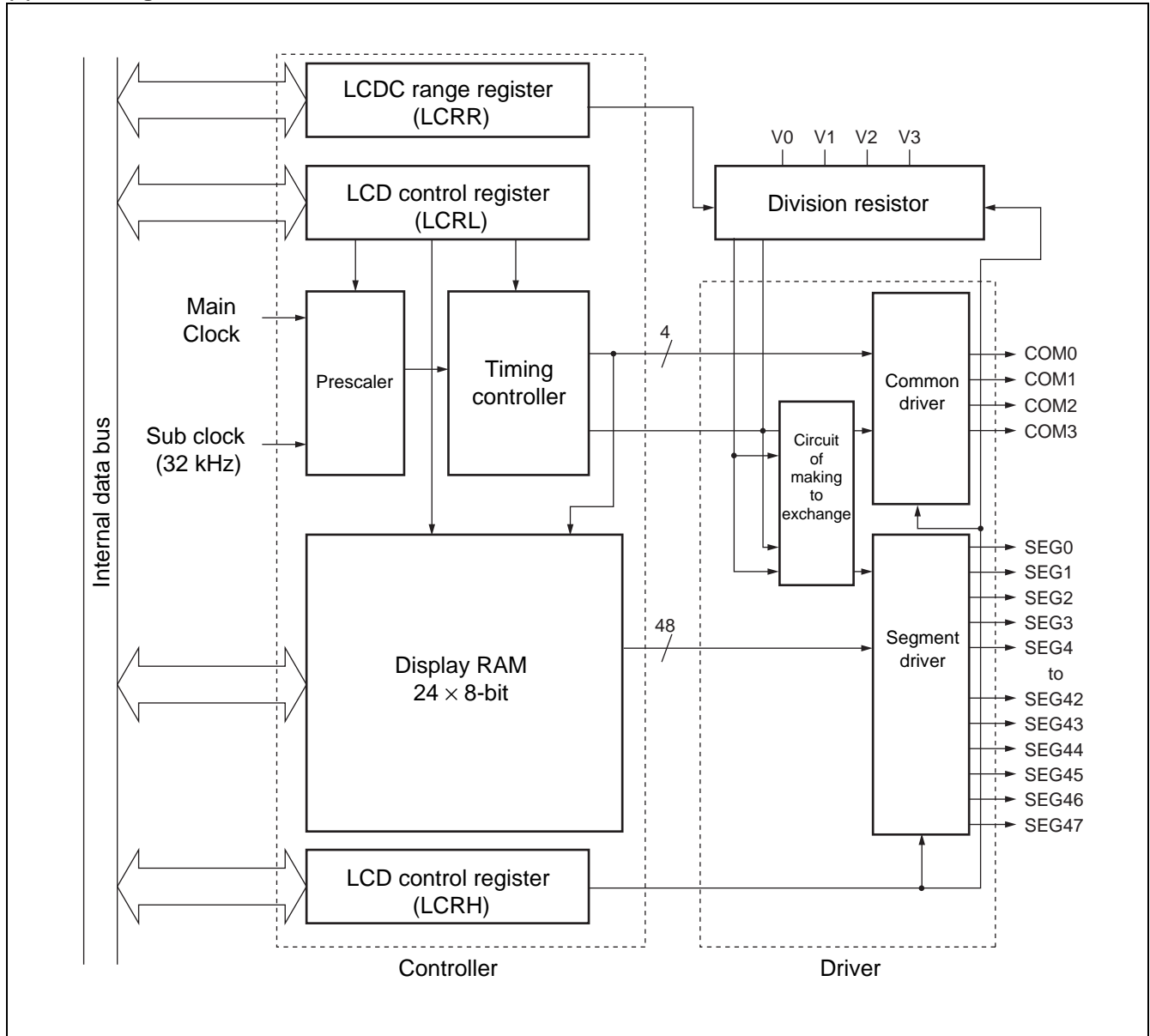

MB90800 Series

■ ELECTRICAL CHARACTERISTICS

1. Absolute Maximum Ratings

Parameter	Symbol	Rating		Unit	Remarks
		Min	Max		
Power supply voltage*1	V_{CC}	$V_{SS} - 0.3$	$V_{SS} + 4.0$	V	
	AV_{CC}	$V_{SS} - 0.3$	$V_{SS} + 4.0$	V	$V_{CC} \geq AV_{CC}$ *2
Input voltage*1	V_I	$V_{SS} - 0.3$	$V_{SS} + 4.0$	V	*3
		$V_{SS} - 0.3$	$V_{SS} + 6.0$	V	N-ch open-drain (5 V withstand voltage/O) *4
Output voltage*1	V_O	$V_{SS} - 0.3$	$V_{SS} + 4.0$	V	*3
“L” level maximum output current	I_{OL11}	—	10	mA	Other than P74, P75, P40 to P47*5
	I_{OL12}	—	30	mA	P74, P75, P40 to P47 (Heavy-current output port) *5
“L” level average output current	I_{OLAV1}	—	3	mA	Other than P74, P75, P40 to P47*6
	I_{OLAV2}	—	15	mA	P74, P75, P40 to P47 (Heavy-current output port) *6
“L” level maximum total output current	ΣI_{OL}	—	120	mA	
“L” level average total output current	ΣI_{OLAV}	—	60	mA	*7
“H” level maximum output current	I_{OH11}	—	- 10	mA	Other than P74, P75, P40 to P47*5
	I_{OH12}	—	- 12	mA	P40 to P47 (Heavy-current output port) *5
“H” level average output current	I_{OHAV}	—	- 3	mA	*6
“H” level maximum total output current	ΣI_{OH}	—	- 120	mA	
“H” level average total output current	ΣI_{OHAV}	—	- 60	mA	*7
Power consumption	P_d	—	351	mW	
Operating temperature	T_A	- 40	+ 85	°C	
Storage temperature	T_{STG}	- 55	+ 150	°C	

*1 : The parameter is based on $V_{SS} = AV_{SS} = 0.0$ V.

*2 : AV_{CC} should not be exceeding V_{CC} at power-on etc.

*3 : V_I , V_O , should not exceed $V_{CC} + 0.3$ V.

*4 : Applicable to pins : P74, P75

*5 : A peak value of an applicable one pin is specified as a maximum output current.

*6 : An average current value of an applicable one pin within 100 ms is specified as an average output current.
(Average value is found by multiplying operating current by operating rate.)

*7 : An average current value of all pins within 100 ms is specified as an average total output current.
(Average value is found by multiplying operating current by operating rate.)

WARNING: Semiconductor devices can be permanently damaged by application of stress (voltage, current, temperature, etc.) in excess of absolute maximum ratings. Do not exceed these ratings.

2. Recommended Operating Conditions

($V_{SS} = AV_{SS} = 0.0\text{ V}$)

Parameter	Symbol	Value		Unit	Remarks
		Min	Max		
Power supply voltage	V_{CC}	2.7	3.6	V	At normal operating
		1.8	3.6	V	Stop operation state maintenance
“H” level input voltage	V_{IH}	$0.7 V_{CC}$	$V_{CC} + 0.3$	V	CMOS input pin
	V_{IHS}	$0.8 V_{CC}$	$V_{CC} + 0.3$	V	CMOS hysteresis input pin (Resisting pressure of 5 V is $V_{CC} = 5.0\text{ V}$)
	V_{IHM}	$V_{CC} - 0.3$	$V_{CC} + 0.3$	V	MD pin input
“L” level input voltage	V_{IL}	$V_{SS} - 0.3$	$0.3 V_{CC}$	V	CMOS input pin
	V_{ILS}	$V_{SS} - 0.3$	$0.2 V_{CC}$	V	CMOS hysteresis input pin
	V_{ILM}	$V_{SS} - 0.3$	$V_{SS} + 0.3$	V	MD pin input
Operating temperature	T_A	- 40	+ 85	°C	

WARNING: The recommended operating conditions are required in order to ensure the normal operation of the semiconductor device. All of the device's electrical characteristics are warranted when the device is operated within these ranges.

Always use semiconductor devices within their recommended operating condition ranges. Operation outside these ranges may adversely affect reliability and could result in device failure.

No warranty is made with respect to uses, operating conditions, or combinations not represented on the data sheet. Users considering application outside the listed conditions are advised to contact their representatives beforehand.

MB90800 Series

3. DC Characteristics

($V_{CC} = AV_{CC} = 3.3\text{ V} \pm 0.3\text{ V}$, $V_{SS} = AV_{SS} = 0.0\text{ V}$, $T_A = -40\text{ }^\circ\text{C}$ to $+85\text{ }^\circ\text{C}$)

Parameter	Symbol	Pin name	Conditions	Value			Unit	Remarks
				Min	Typ	Max		
“H” level output voltage	V_{OH}	Output pins other than P40 to P47, P74, P75	$I_{OH} = -4.0\text{ mA}$	$V_{CC} - 0.5$	—	V_{CC}	V	
	V_{OH1}	P40 to P47	$I_{OH} = -8.0\text{ mA}$	$V_{CC} - 0.5$	—	V_{CC}	V	Heavy-current output port
“L” level output voltage	V_{OL}	Output pins other than P40 to P47, P74, P75	$I_{OL} = 4.0\text{ mA}$	V_{SS}	—	$V_{SS} + 0.4$	V	
	V_{OL1}	P40 to P47	$I_{OL} = 15.0\text{ mA}$	V_{SS}	—	$V_{SS} + 0.6$	V	Heavy-current output port
	V_{OL2}	P74, P75	$I_{OL} = 15.0\text{ mA}$	—	0.5	$V_{SS} + 0.8$	V	Open-drain pin
Open-drain output application voltage	V_{D1}	P74, P75	—	$V_{SS} - 0.3$	—	$V_{SS} + 5.5$	V	
Input leak current	I_{IL}	All output pins	$V_{CC} = 3.3\text{ V}$, $V_{SS} < V_I < V_{CC}$	-10	—	+10	μA	
Pull-up resistor	R_{UP}	$\overline{\text{RST}}$	$V_{CC} = 3.3\text{ V}$, $T_A = +25\text{ }^\circ\text{C}$	25	50	100	$\text{k}\Omega$	
Pull-down resistor	R_{DOWN}	MD2	$V_{CC} = 3.3\text{ V}$, $T_A = +25\text{ }^\circ\text{C}$	25	50	100	$\text{k}\Omega$	Except Flash memory products
Open drain output current	I_{leak}	P74, P75	—	—	0.1	10	μA	
Power supply current	I_{CC}	V_{CC}	$V_{CC} = 3.3\text{ V}$, Internal frequency 25 MHz At normal operating	—	48	60	mA	
			$V_{CC} = 3.3\text{ V}$, Internal frequency 25 MHz At Flash writing	—	60	75	mA	Flash memory products
			$V_{CC} = 3.3\text{ V}$, Internal frequency 25 MHz At Flash erasing	—	60	75	mA	Flash memory products
	I_{CCS}	$V_{CC} = 3.3\text{ V}$, Internal frequency 25 MHz at sleep mode	—	22.5	30	mA		

(Continued)

(Continued)

($V_{CC} = AV_{CC} = 3.3\text{ V} \pm 0.3\text{ V}$, $V_{SS} = AV_{SS} = 0.0\text{ V}$, $T_A = -40\text{ }^\circ\text{C}$ to $+85\text{ }^\circ\text{C}$)

Parameter	Symbol	Pin name	Conditions	Value			Unit	Remarks
				Min	Typ	Max		
Power supply current	I_{CCTS}	V_{CC}	$V_{CC} = 3.3\text{ V}$, Internal frequency 3 MHz at timer mode	—	0.75	7	mA	
	I_{CCL}		$V_{CC} = 3.3\text{ V}$, Internal frequency 8 kHz at subclock operation, ($T_A = +25\text{ }^\circ\text{C}$)	—	15	140	μA	MASK ROM products
				—	0.5	0.9	mA	Flash memory products
	I_{CCLS}		$V_{CC} = 3.3\text{ V}$, Internal frequency 8 kHz at subclock sleep operation, ($T_A = +25\text{ }^\circ\text{C}$)	—	13	40	μA	
	I_{CCT}		$V_{CC} = 3.3\text{ V}$, Internal frequency 8 kHz at watch mode ($T_A = +25\text{ }^\circ\text{C}$)	—	1.8	40	μA	
	I_{CCH}		At Stop mode, ($T_A = +25\text{ }^\circ\text{C}$)	—	0.8	40	μA	
LCD division resistance	R_{LCD}	$V_{CC} - V3$	At LCR = 0 setting	100	200	400	k Ω	*
		$V_{CC} - V3$	At LCR = 1 setting	12.5	25	50		
		$V0 - V1$, $V1 - V2$, $V2 - V3$	At LCR = 0 setting	50	100	200		
		$V0 - V1$, $V1 - V2$, $V2 - V3$	At LCR = 1 setting	6.25	12.5	25		
COM0 to COM3 output impedance	R_{VCOM}	COM0 to COM3	$V1$ to $V3 = 3.3\text{ V}$	—	—	2.5	k Ω	
SEG0 to SEG47 output impedance	R_{VSEG}	SEG0 to SEG47		—	—	15	k Ω	
LCD leak current	I_{LCDC}	$V0$ to $V3$, COM0 to COM3, SEG0 to SEG47	—	-5	—	+5	μA	

* : LCD internal divided resistor can be select two type resistor by internal divided resistor selecting bit (LCR) of LCDC range register (LCRR) .

MB90800 Series

4. AC Characteristics

(1) Clock timing

($V_{CC} = AV_{CC} = 3.3 \text{ V} \pm 0.3 \text{ V}$, $V_{SS} = AV_{SS} = 0.0 \text{ V}$, $T_A = -40 \text{ }^\circ\text{C}$ to $+85 \text{ }^\circ\text{C}$)

Parameter	Symbol	Pin name	Conditions	Value			Unit	Remarks
				Min	Typ	Max		
Clock frequency	f _{CH}	X0, X1	—	3	—	16	MHz	External crystal oscillation
				3		16		× 1/2 (at PLL stop) At oscillation circuit
				4		16		Multiply by 1 At oscillation circuit
				4		12.5		Multiply by 2 At oscillation circuit
				4		8.33		Multiply by 3 At oscillation circuit
				4		6.25		Multiply by 4 At oscillation circuit
	X0	3		25	× 1/2 (at PLL stop) At external clock			
		4		25	Multiply by 1 At external clock			
		4		12.5	Multiply by 2 At external clock			
		4		8.33	Multiply by 3 At external clock			
		4		6.25	Multiply by 4 At external clock			
		f _{CL}		X0A, X1A	—	32.768		—
Clock cycle time	t _{H CYL}	X0, X1	40	—	333	ns		
	t _{L CYL}	X0A, X1A	—	30.5	—	μs		
Input clock pulse width	P _{WH} P _{WL}	X0	5	—	—	ns	Set duty ratio 50% ± 3%	
	P _{WLH} P _{WLL}	X0A	—	15.2	—	μs	Set duty ratio at 30% to 70% as a guideline.	
Input clock rise time and fall time	t _{cr} t _{cf}	X0	—	—	5	ns	At external clock	
Internal operating clock frequency	f _{CP}	—	1.5	—	25	MHz	When main clock is used	
	f _{CP1}	—	—	8.192	—	kHz	When sub clock is used	
Internal operating clock cycle time	t _{CP}	—	40	—	666	ns	When main clock is used	
	t _{CP1}	—	—	122.1	—	μs	When sub clock is used	

- X0, X1 clock timing

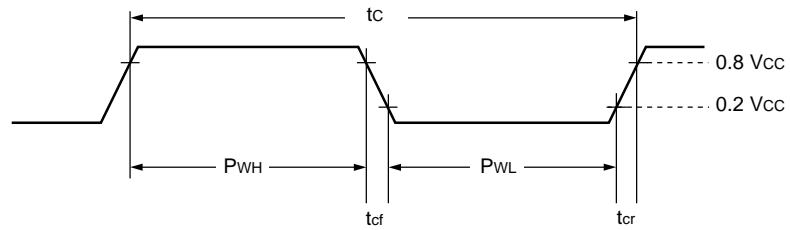

- X0A, X1A clock timing

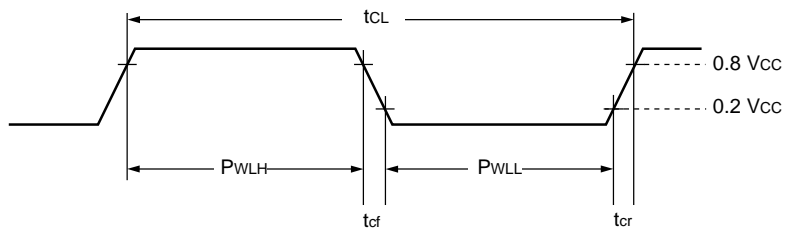

- PLL operation guarantee range

Relation between internal operation clock frequency and power supply voltage

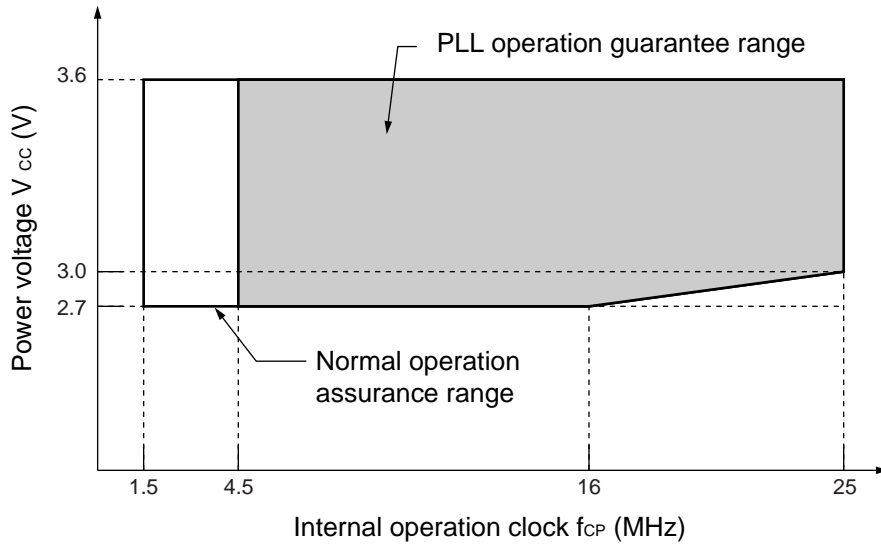

Relation between oscillation clock frequency and internal operating clock frequency

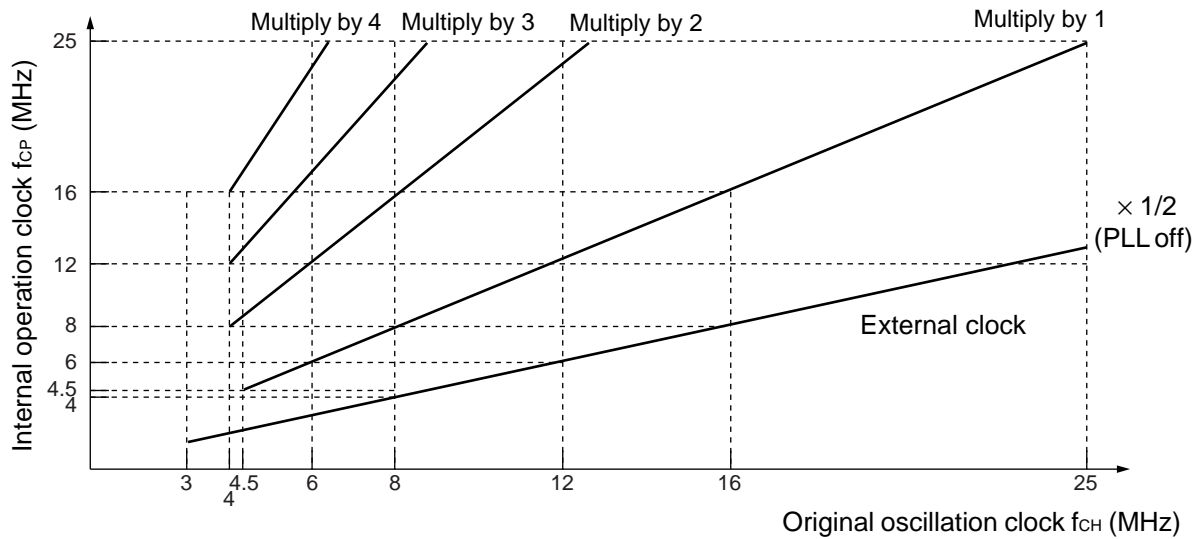

Rating values of alternating current is defined by the measurement reference voltage values shown below :

- Input signal waveform

Hysteresis input pin

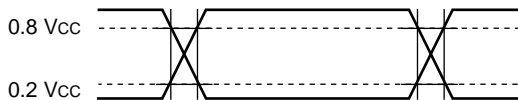

- Output signal waveform

Output pin

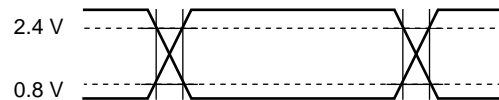

(2) Reset input timing

($V_{CC} = AV_{CC} = 3.3 \text{ V} \pm 0.3 \text{ V}$, $V_{SS} = AV_{SS} = 0.0 \text{ V}$, $T_A = -40 \text{ }^\circ\text{C}$ to $+85 \text{ }^\circ\text{C}$)

Parameter	Symbol	Pin name	Conditions	Value		Unit	Remarks
				Min	Max		
Reset input time	t_{RSTL}	\overline{RST}	—	500	—	ns	At normal operating, at time base timer mode, at main sleep mode, at PLL sleep mode
				Oscillation time of oscillator*+ 500 ns	—	μs	At stop mode, at sub clock mode, at sub sleep mode, at watch mode

* : Oscillation time of oscillator is time until oscillation reaches 90% of amplitude. It takes several milliseconds to several dozens of milliseconds on a crystal oscillator, several hundreds of microseconds to several milliseconds on a ceramic oscillator, and 0 milliseconds on an external clock.

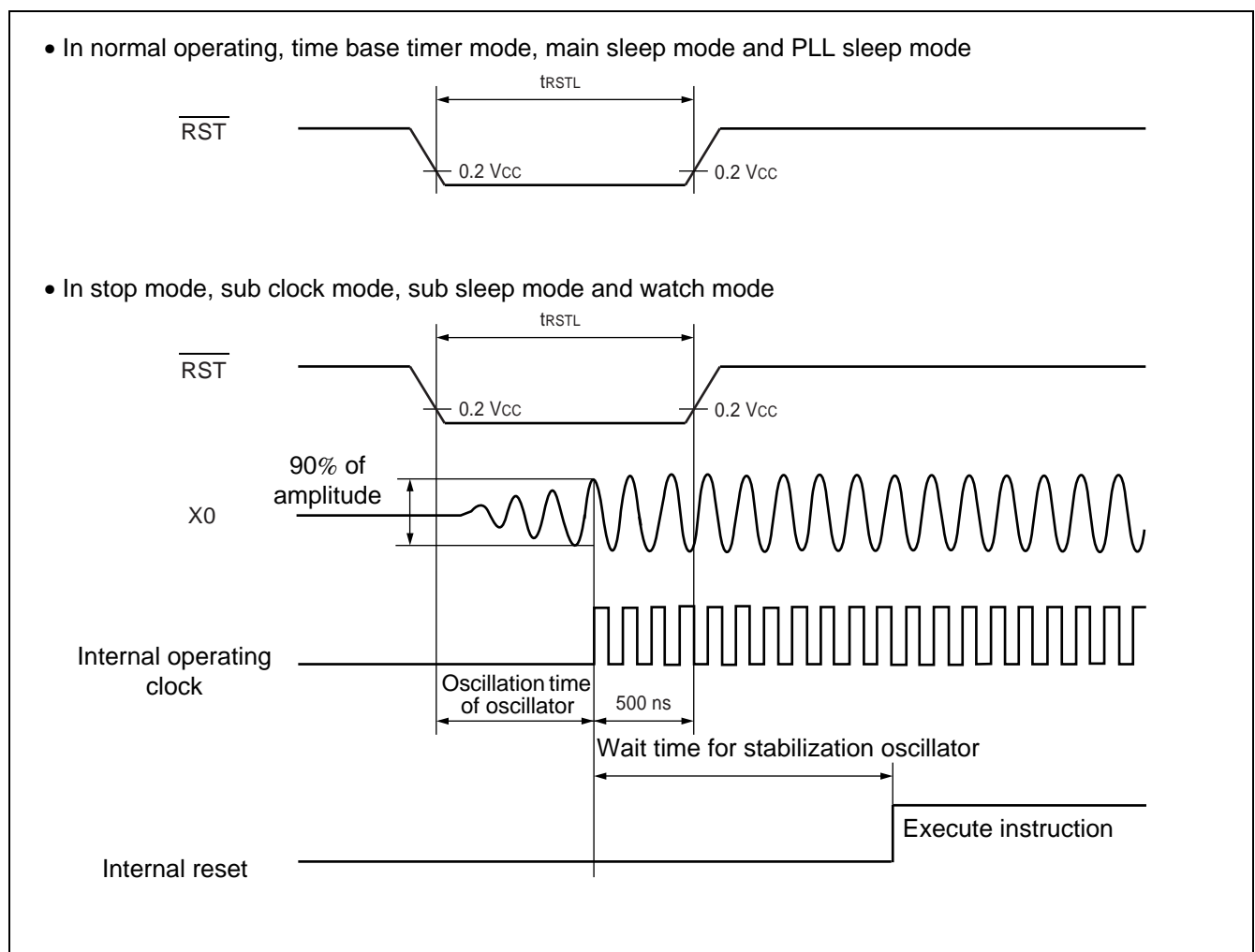

MB90800 Series

(3) Power-on reset

($V_{CC} = AV_{CC} = 3.3 \text{ V} \pm 0.3 \text{ V}$, $V_{SS} = AV_{SS} = 0.0 \text{ V}$, $T_A = -40 \text{ }^\circ\text{C}$ to $+85 \text{ }^\circ\text{C}$)

Parameter	Symbol	Pin name	Condi- tions	Value		Unit	Remarks
				Min	Max		
Power supply rising time	t_R	V_{CC}	—	—	30	ms	At normal operating
Power supply shutdown time	t_{OFF}	V_{CC}	—	1	—	ms	Wait time until power on

- Notes :
- V_{CC} should be set under 0.2 V before power-on rising up.
 - These value are for power-on reset.
 - In the device, there are internal registers which is initialized only by a power-on reset. If these initialization is executing, power-on procedure must be obeyed by these value.

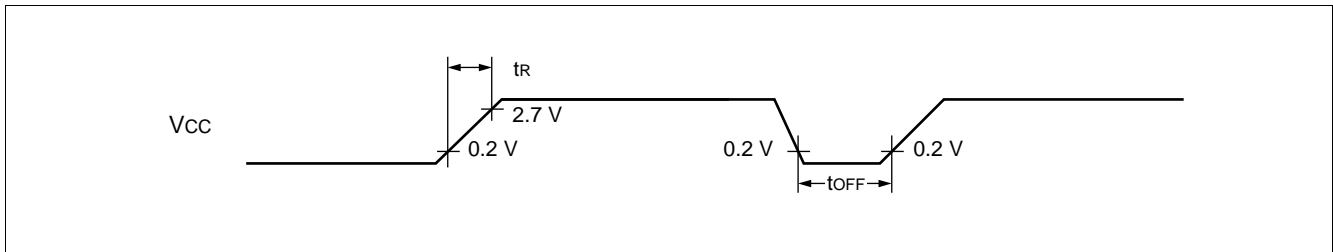

Note : Sudden change of power supply voltage may activate the power-on reset function. When changing power supply voltages during operation, raise the power smoothly by suppressing variation of voltages as shown below.

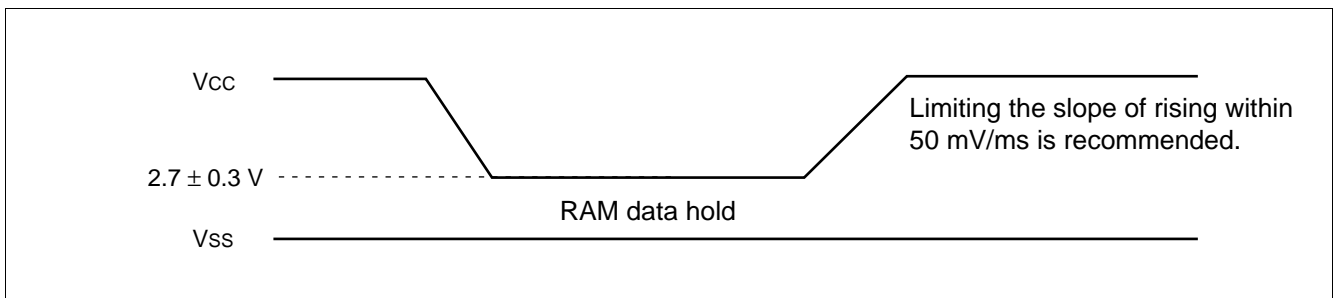

(4) Serial I/O

($V_{CC} = AV_{CC} = 3.3\text{ V} \pm 0.3\text{ V}$, $V_{SS} = AV_{SS} = 0.0\text{ V}$, $T_A = -40\text{ }^\circ\text{C}$ to $+85\text{ }^\circ\text{C}$)

Parameter	Symbol	Pin name	Conditions	Value		Unit
				Min	Max	
Serial clock cycle time	t_{SCYC}	SC0 to SC3	Internal shift clock mode output pin : $C_L = 80\text{ pF} + 1\text{TTL}$	8 t_{CP}	—	ns
SCK ↓ → SOT delay time	t_{SLOV}	SC0 to SC3, SO0 to SO3		-80	+80	ns
Valid SIN → SCK ↑	t_{IVSH}	SC0 to SC3, SI0 to SI3		100	—	ns
SCK ↑ → Valid SIN hold time	t_{SHIX}		60	—	ns	
Serial clock "H" pulse width	t_{SHSL}	SC0 to SC3	External shift clock mode output pin : $C_L = 80\text{ pF} + 1\text{TTL}$	4 t_{CP}	—	ns
Serial clock "L" pulse width	t_{SLSH}			4 t_{CP}	—	ns
SCK ↓ → SOT delay time	t_{SLOV}	SC0 to SC3, SO0 to SO3		—	150	ns
Valid SIN → SCK ↑	t_{IVSH}	SC0 to SC3, SI0 to SI3		60	—	ns
SCK ↑ → valid SIN hold time	t_{SHIX}		60	—	ns	

- Notes :
- The above rating is in CLK synchronous mode.
 - C_L is a load capacitance value on pins for testing.
 - t_{CP} is machine cycle frequency (ns) . Refer to "(1) Clock timing".

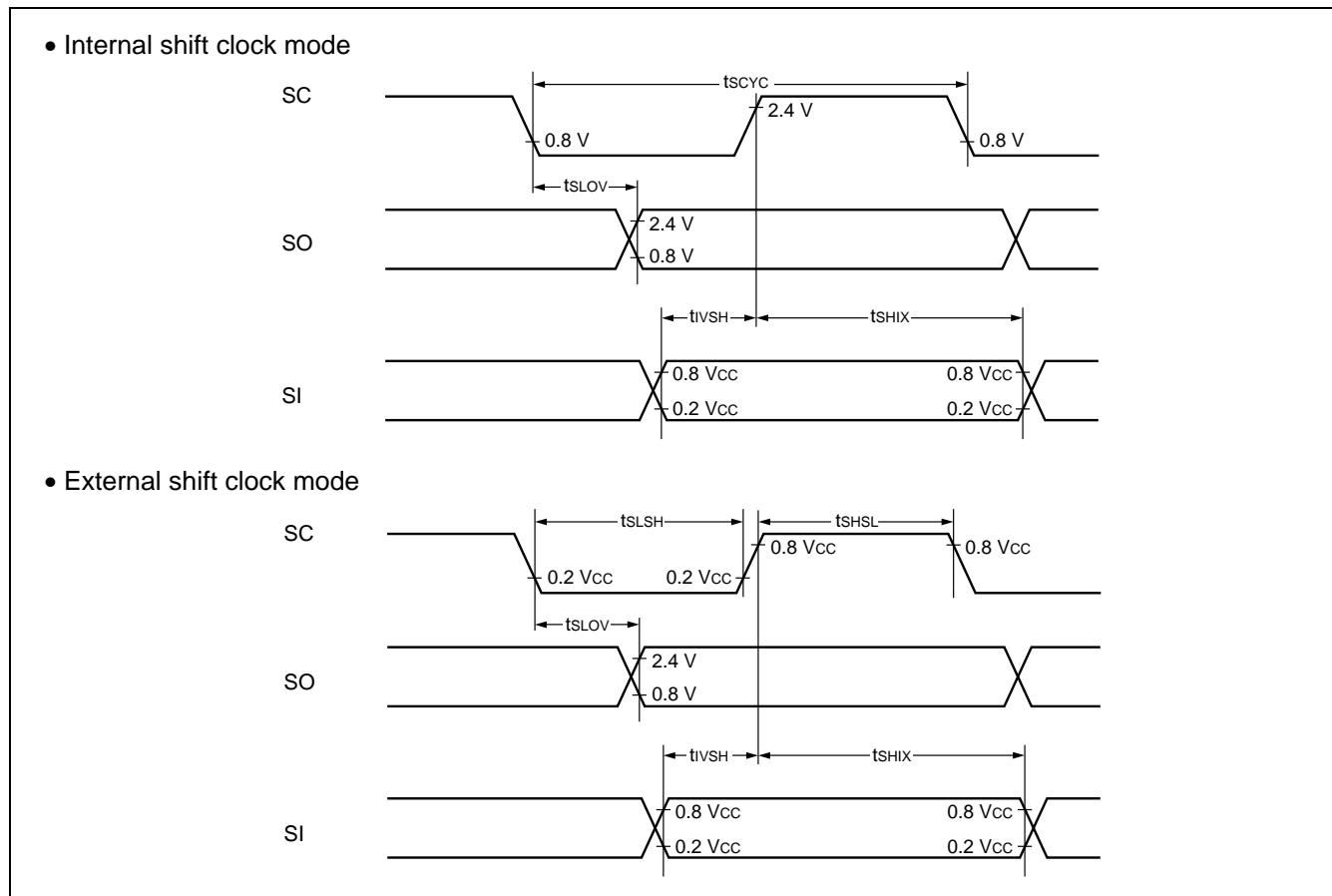

MB90800 Series

(5) Timer input timing

($V_{CC} = AV_{CC} = 3.3 \text{ V} \pm 0.3 \text{ V}$, $V_{SS} = AV_{SS} = 0.0 \text{ V}$, $T_A = -40 \text{ }^\circ\text{C}$ to $+85 \text{ }^\circ\text{C}$)

Parameter	Symbol	Pin name	Conditions	Value		Unit
				Min	Max	
Input pulse width	t_{TIWH} t_{TIWL}	TIN0 to TIN2, IC0, IC1	—	$4 t_{CP}$	—	ns

Note : t_{CP} is machine cycle frequency (ns) . Refer to “ (1) Clock timing”.

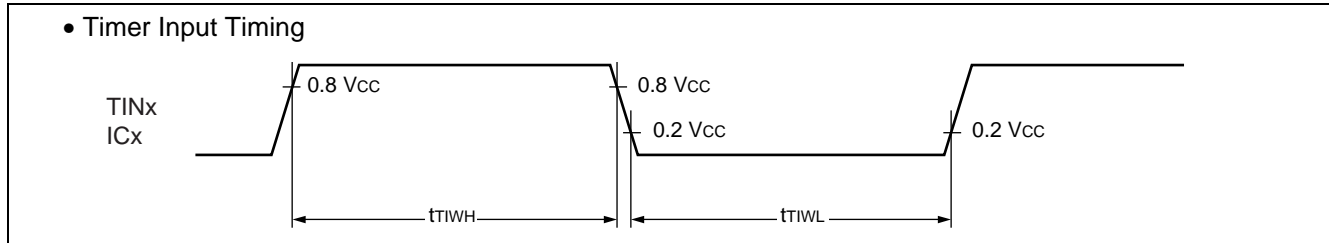

(6) Timer output timing

($V_{CC} = AV_{CC} = 3.3 \text{ V} \pm 0.3 \text{ V}$, $V_{SS} = AV_{SS} = 0.0 \text{ V}$, $T_A = -40 \text{ }^\circ\text{C}$ to $+85 \text{ }^\circ\text{C}$)

Parameter	Symbol	Pin name	Conditions	Value		Unit
				Min	Max	
CLK \uparrow \rightarrow TOUT change time	t_{TO}	TOT0 to TOT2, PPG0, PPG1, OCU0, OCU1	—	30	—	ns

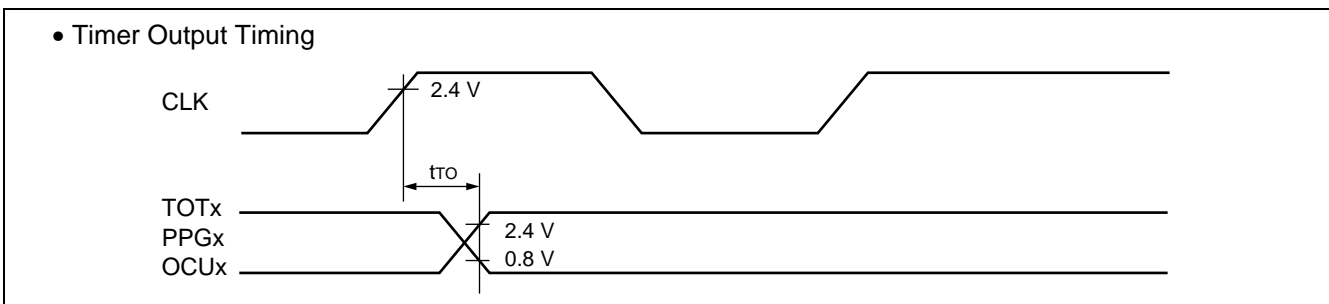

(7) Trigger input timing

($V_{CC} = AV_{CC} = 3.3 \text{ V} \pm 0.3 \text{ V}$, $V_{SS} = AV_{SS} = 0.0 \text{ V}$, $T_A = -40 \text{ }^\circ\text{C}$ to $+85 \text{ }^\circ\text{C}$)

Parameter	Symbol	Pin name	Condi-tions	Value		Unit	Remarks
				Min	Max		
Input pulse width	t_{TRGH}	INT0 to INT3	—	$5 t_{CP}$	—	ns	At normal operating
	t_{TRGL}			1	—	μs	In Stop mode

Note : t_{CP} is machine cycle frequency (ns) . Refer to “ (1) Clock timing”.

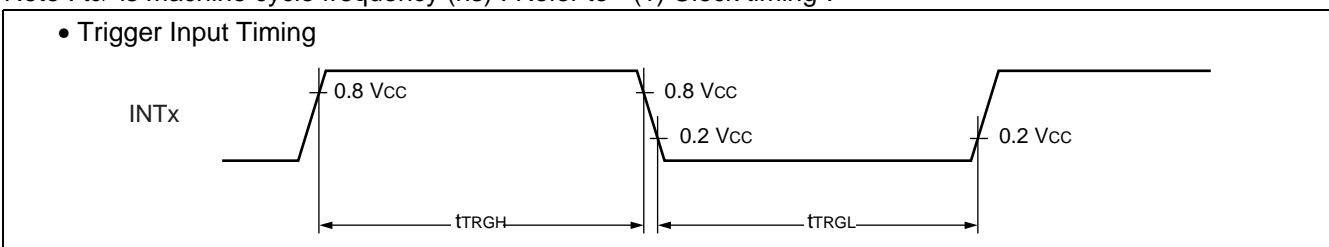

(8) I²C timing

($V_{CC} = V_{CC} = 3.3 \text{ V} \pm 0.3 \text{ V}$, $V_{SS} = AV_{SS} = 0.0 \text{ V}$, $T_A = -40 \text{ }^\circ\text{C}$ to $+85 \text{ }^\circ\text{C}$)

Parameter	Symbol	Conditions	Standard-mode		Unit
			Min	Max	
SCL clock frequency	f_{SCL}		0	100	kHz
Hold time (repeated) START condition SDA $\downarrow \rightarrow$ SCL \downarrow	t_{HDSTA}	When power supply voltage of external pull-up resistor is 5.0 V $R = 1.0 \text{ k}\Omega$, $C = 50 \text{ pF}^{*2}$	4.0	—	μs
“L” width of the SCL clock	t_{LOW}		4.7	—	μs
“H” width of the SCL clock	t_{HIGH}	When power supply voltage of external pull-up resistor is 3.6 V	4.0	—	μs
Set-up time for a repeated START condition SCL $\uparrow \rightarrow$ SDA \downarrow	t_{SUSTA}	$R = 1.0 \text{ k}\Omega$, $C = 50 \text{ pF}^{*2}$	4.7	—	μs
Data hold time SCL $\downarrow \rightarrow$ SDA $\downarrow \uparrow$	t_{HDDAT}		0	3.45 _{*3}	μs
Data set-up time SDA $\uparrow \rightarrow$ SCL \uparrow	t_{SUDAT}	When power supply voltage of external pull-up resistor is 5.0 V $f_{CP}^{*1} \leq 20 \text{ MHz}$, $R = 1.0 \text{ k}\Omega$, $C = 50 \text{ pF}^{*2}$	250 _{*4}	—	ns
		When power supply voltage of external pull-up resistor is 3.6 V $f_{CP}^{*1} \leq 20 \text{ MHz}$, $R = 1.0 \text{ k}\Omega$, $C = 50 \text{ pF}^{*2}$			
Set-up time for STOP condition SCL $\uparrow \rightarrow$ SDA \uparrow	t_{SUSTO}	When power supply voltage of external pull-up resistor is 5.0 V $f_{CP}^{*1} > 20 \text{ MHz}$, $R = 1.0 \text{ k}\Omega$, $C = 50 \text{ pF}^{*2}$	200 _{*4}	—	ns
		When power supply voltage of external pull-up resistor is 3.6 V $f_{CP}^{*1} > 20 \text{ MHz}$, $R = 1.0 \text{ k}\Omega$, $C = 50 \text{ pF}^{*2}$			
Bus free time between a STOP and START condition	t_{BUS}	When power supply voltage of external pull-up resistor is 5.0 V $R = 1.0 \text{ k}\Omega$, $C = 50 \text{ pF}^{*2}$	4.0	—	μs
		When power supply voltage of external pull-up resistor is 3.6 V $R = 1.0 \text{ k}\Omega$, $C = 50 \text{ pF}^{*2}$	4.7	—	μs

*1 : f_{CP} is internal operation clock frequency. Refer to “(1) Clock timing”.

*2 : R, C : Pull-up resistor and load capacitor of the SCL and SDA lines.

*3 : The maximum t_{HDDAT} only has to be met if the device does not stretch the “L” width (t_{LOW}) of the SCL signal.

*4 : Refer to “• Note of SDA and SCL set-up time”.

- Note of SDA and SCL set-up time

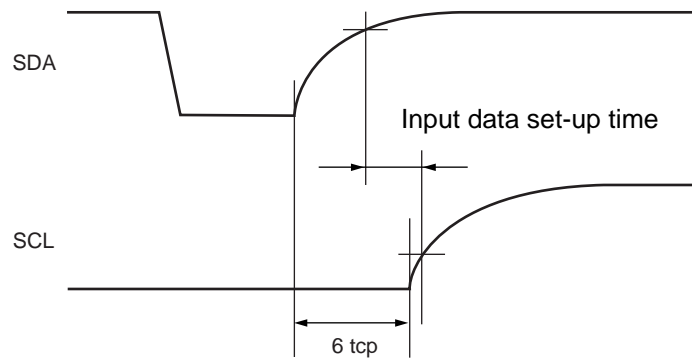

Note : The rating of the input data set-up time in the device connected to the bus cannot be satisfied depending on the load capacitance or pull-up resistor.
Be sure to adjust the pull-up resistor of SDA and SCL if the rating of the input data set-up time cannot be satisfied.

- Timing definition

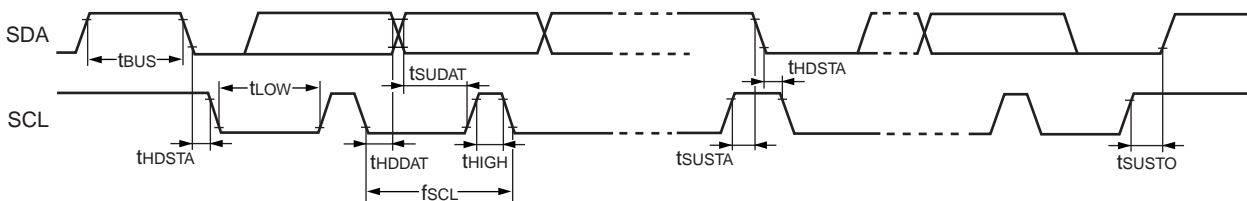

5. A/D Converter

(1) A/D Converter Electrical Characteristics

($V_{CC} = AV_{CC} = 3.3 \text{ V} \pm 0.3 \text{ V}$, $V_{SS} = AV_{SS} = 0.0 \text{ V}$, $T_A = -40^\circ\text{C}$ to $+85^\circ\text{C}$)

Parameter	Symbol	Pin name	Conditions	Value			Unit	Remarks
				Min	Typ	Max		
Resolution	—	—	—	—	—	10	bit	
Total error	—	—		—	—	± 3.0	LSB	
Nonlinear error	—	—		—	—	± 2.5	LSB	
Differential linear error	—	—		—	—	± 1.9	LSB	
Zero transition voltage	V_{OT}	ANO to AN11		$AV_{SS} - 1.5\text{LSB}$	$AV_{SS} + 0.5\text{LSB}$	$AV_{SS} + 2.5\text{LSB}$	V	1 LSB = $(AV_{CC} - AV_{SS}) / 1024$
Full-scale transition voltage	V_{FST}	ANO to AN11		$AV_{CC} - 3.5\text{LSB}$	$AV_{CC} - 1.5\text{LSB}$	$AV_{CC} + 0.5\text{LSB}$	V	
Conversion time	—	—		8.64*1	—	—	μs	
Sampling time	—	—		2	—	—	μs	
Analog port input current	I_{AIN}	ANO to AN11		—	—	10	μA	
Analog input voltage	V_{AIN}	ANO to AN11		0	—	AV_{CC}	V	
Reference voltage	—	AV_{CC}		3.0	—	AV_{CC}	V	
Power supply current	I_A	AV_{CC}		—	1.4	3.5	mA	
	I_{AH}	AV_{CC}		—	—	5*2	μA	
Reference voltage supplying current	I_R	AV_{CC}		—	94	150	μA	
	I_{RH}	AV_{CC}	—	—	5*2	μA		
Interchannel disparity	—	ANO to AN11	—	—	4	LSB		

*1 : At operating, main clock 25 MHz.

*2 : If A/D converter is not operating, a current when CPU is stopped is applicable (at $V_{CC} - \text{CPU} = AV_{CC} = 3.3 \text{ V}$)

MB90800 Series

(2) Notes on Using A/D Converter

• About the external impedance of analog input and its sampling time

A/D converter with sample & hold circuit. If the external impedance is too high to keep sufficient sampling time, the analog voltage charged to the internal sample and hold capacitor is insufficient, adversely affecting A/D conversion precision. Therefore, to satisfy the A/D conversion precision standard, consider the relationship between the external impedance and minimum sampling time and either adjust the resistor value and operating frequency or decrease the external impedance so that the sampling time is longer than the minimum value. And, if the sampling time cannot be sufficient, connect a capacitor of about 0.1 μF to the analog input pin.

• Analog input circuit model

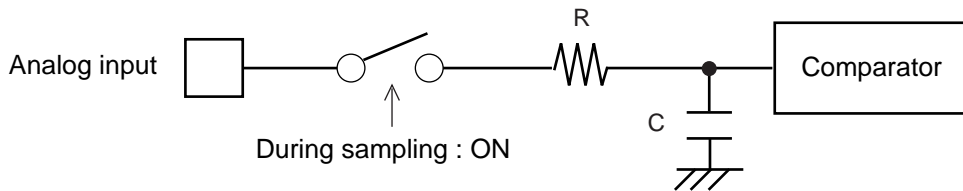

	R	C
MB90803 (S)	1.9 k Ω (Max)	32.3 pF (Max)
MB90F804-201(101)/F803(S)/F809(S)	1.9 k Ω (Max)	25.0 pF (Max)
MB90V800	1.9 k Ω (Max)	32.3 pF (Max)

Note : The values are reference values.

• The relationship between external impedance and minimum sampling time

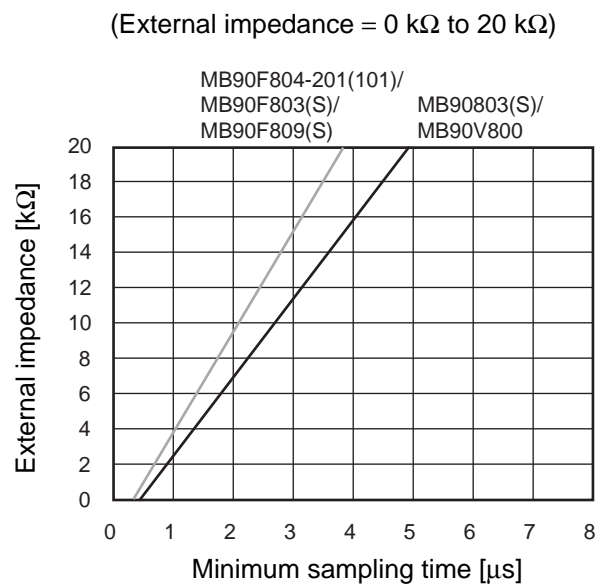
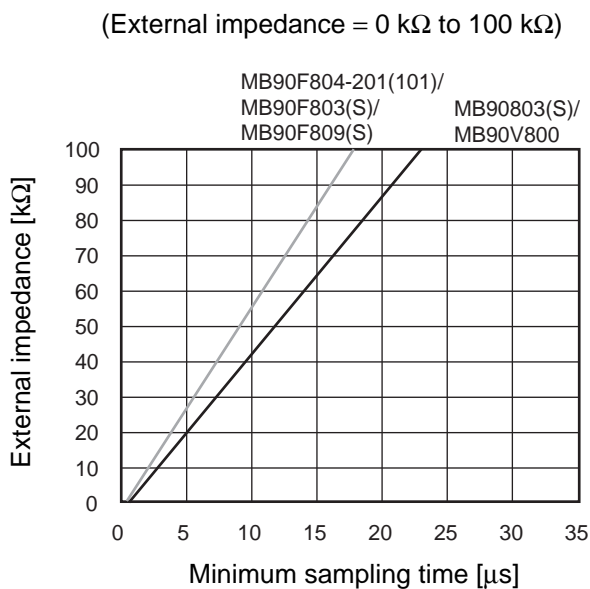

• About errors

As $|AV_{CC} - AV_{SS}|$ becomes smaller, values of relative errors grow larger.

6. Definition of A/D Converter Terms

Resolution

Analog variation that is recognized by an A/D converter.

The 10-bit can resolve analog voltage into $2^{10} = 1024$.

Total error

This shows the difference between the actual voltage and the ideal value and means a total of error because of offset error, gain error, non-linearity error and noise.

Linearity error

Deviation between a line across zero-transition line (00 0000 0000↔00 0000 0001) and full-scale transition line (11 1111 1110↔11 1111 1111) and actual conversion characteristics.

Differential linear error

Deviation of input voltage, which is required for changing output code by 1 LSB, from an ideal value.

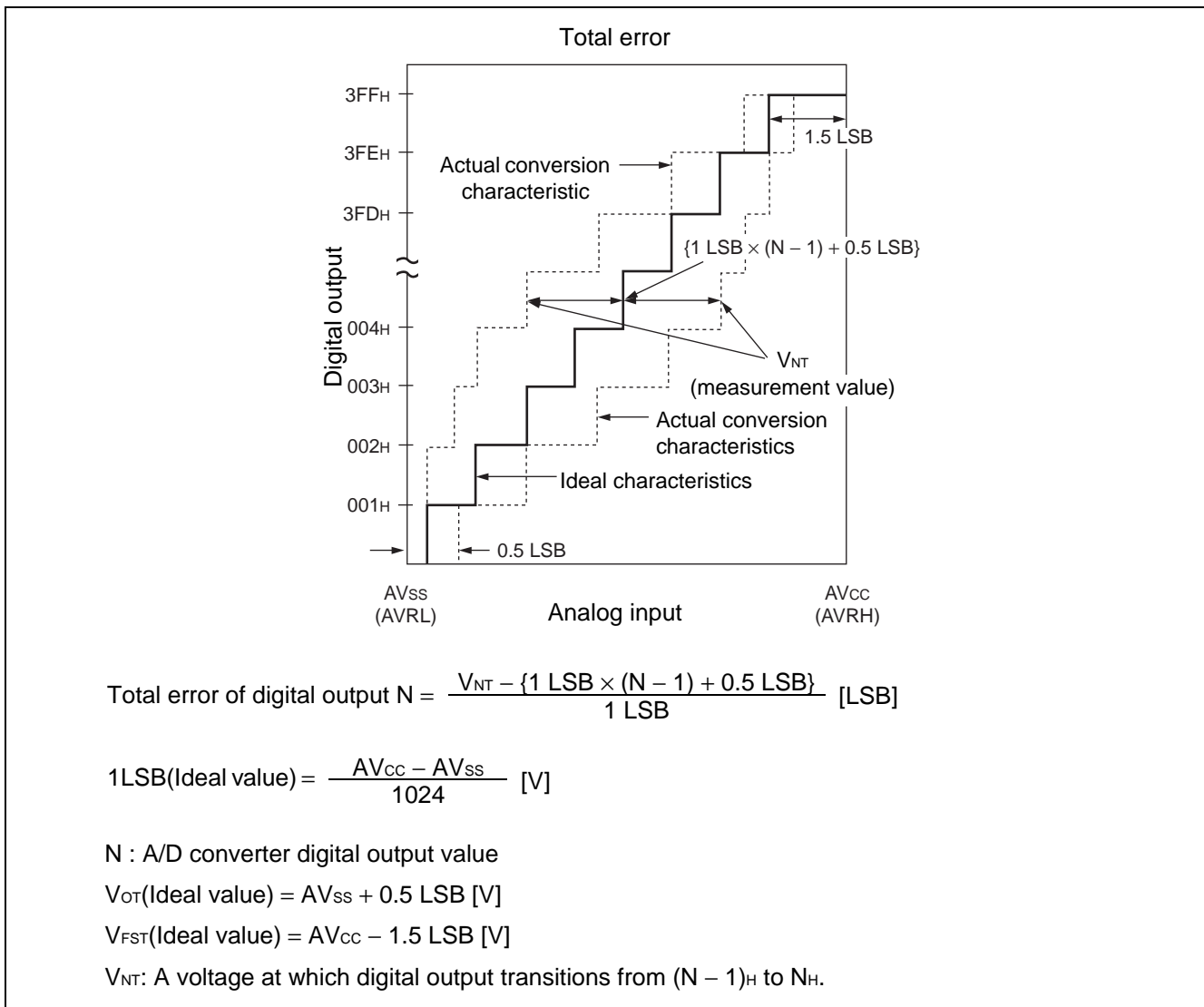

(Continued)

(Continued)

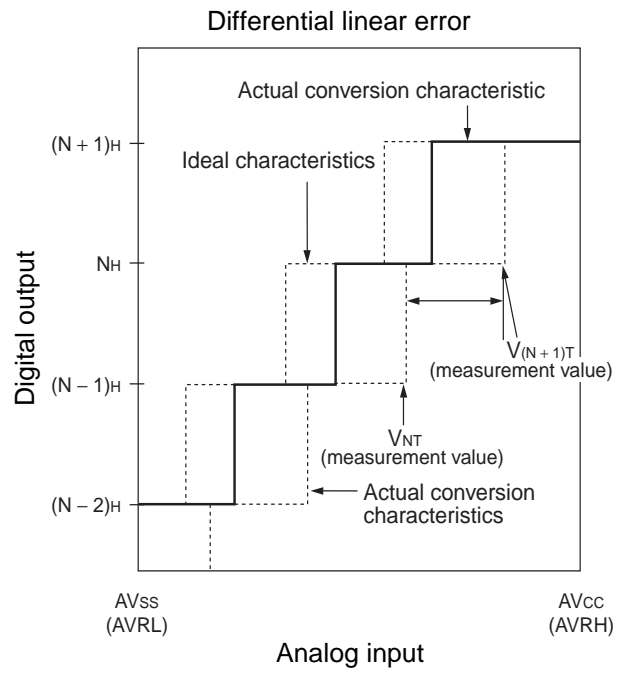
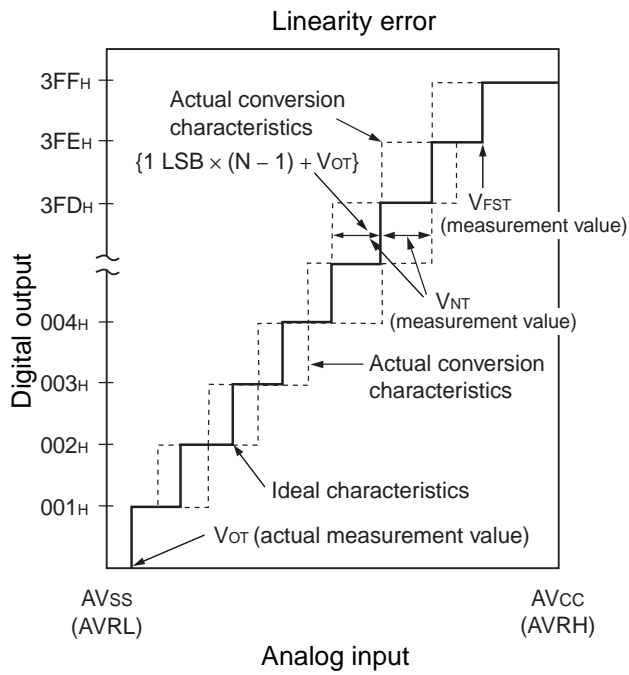

$$\text{Linear error in digital output } N = \frac{V_{NT} - \{1 \text{ LSB} \times (N - 1) + V_{OT}\}}{1 \text{ LSB}} \quad [\text{LSB}]$$

$$\text{Differential linear error in digital output } N = \frac{V_{(N+1)T} - V_{NT}}{1 \text{ LSB}} - 1 \text{ LSB} \quad [\text{LSB}]$$

$$1 \text{ LSB} = \frac{V_{FST} - V_{OT}}{1022} \quad [\text{V}]$$

N : A/D converter digital output value

V_{OT} : Voltage at which digital output transits from 000_H to 001_H.

V_{FST} : Voltage at which digital output transits from 3FE_H to 3FF_H.

7. Flash Memory (MB90F804-101/201, MB90F809/S)

Parameter	Conditions	Value			Unit	Remarks
		Min	Typ	Max		
Sector erase time	T _A = + 25 °C V _{CC} = 3.0 V	—	1	15	s	Excludes 00 _H programming prior to erasure.
Chip erase time		—	9	—		
Word (16-bit width) programming time		—	—	16	3600	μs
Program/erase cycle	—	10000	—	—	cycle	
Flash memory data retention time	Average T _A = + 85 °C	20	—	—	year	*

* : This value comes from the technology qualification (using Arrhenius equation to translate high temperature measurements into normalized value at + 85 °C).

8. Dual Operation Flash Memory (MB90F803/S)

Parameter	Conditions	Value			Unit	Remarks
		Min	Typ	Max		
Sector erase time (4 Kbytes sector)	T _A = +25 °C V _{CC} = 3.0 V	—	0.2	0.5	s	Excludes 00 _H programming prior to erasure.
Sector erase time (16 Kbytes sector)		—	0.5	7.5		
Chip erase time		—	4.6	—		
Word (16-bit width) programming time		—	—	64	3600	μs
Program/erase cycle	—	10000	—	—	cycle	
Flash memory data retention time	Average T _A = + 85 °C	20	—	—	year	*

* : This value comes from the technology qualification (using Arrhenius equation to translate high temperature measurements into normalized value at + 85 °C).

MB90800 Series

■ ORDERING INFORMATION

Part number	Package	Remarks
MB90F804-101PF-G MB90F804-201PF-G MB90F803PF-G MB90F803SPF-G MB90F809PF-G MB90F809SPF-G	100-pin plastic QFP (FPT-100P-M06)	With sub clock: Products without "S" suffix 201 option products Without sub clock: Products with "S" suffix 101 option products
MB90803PF-G MB90803SPF-G		

PACKAGE DIMENSION

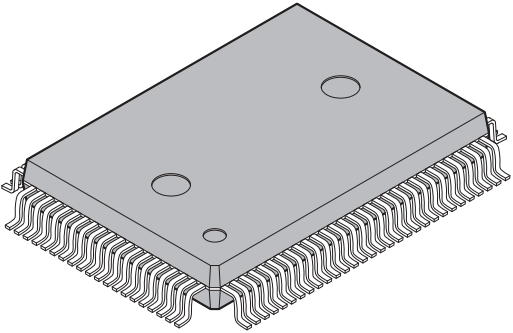
<p>100-pin plastic QFP</p>  <p>(FPT-100P-M06)</p>	Lead pitch	0.65 mm
	Package width × package length	14.00 × 20.00 mm
	Lead shape	Gullwing
	Sealing method	Plastic mold
	Mounting height	3.35 mm MAX
	Code (Reference)	P-QFP100-14×20-0.65

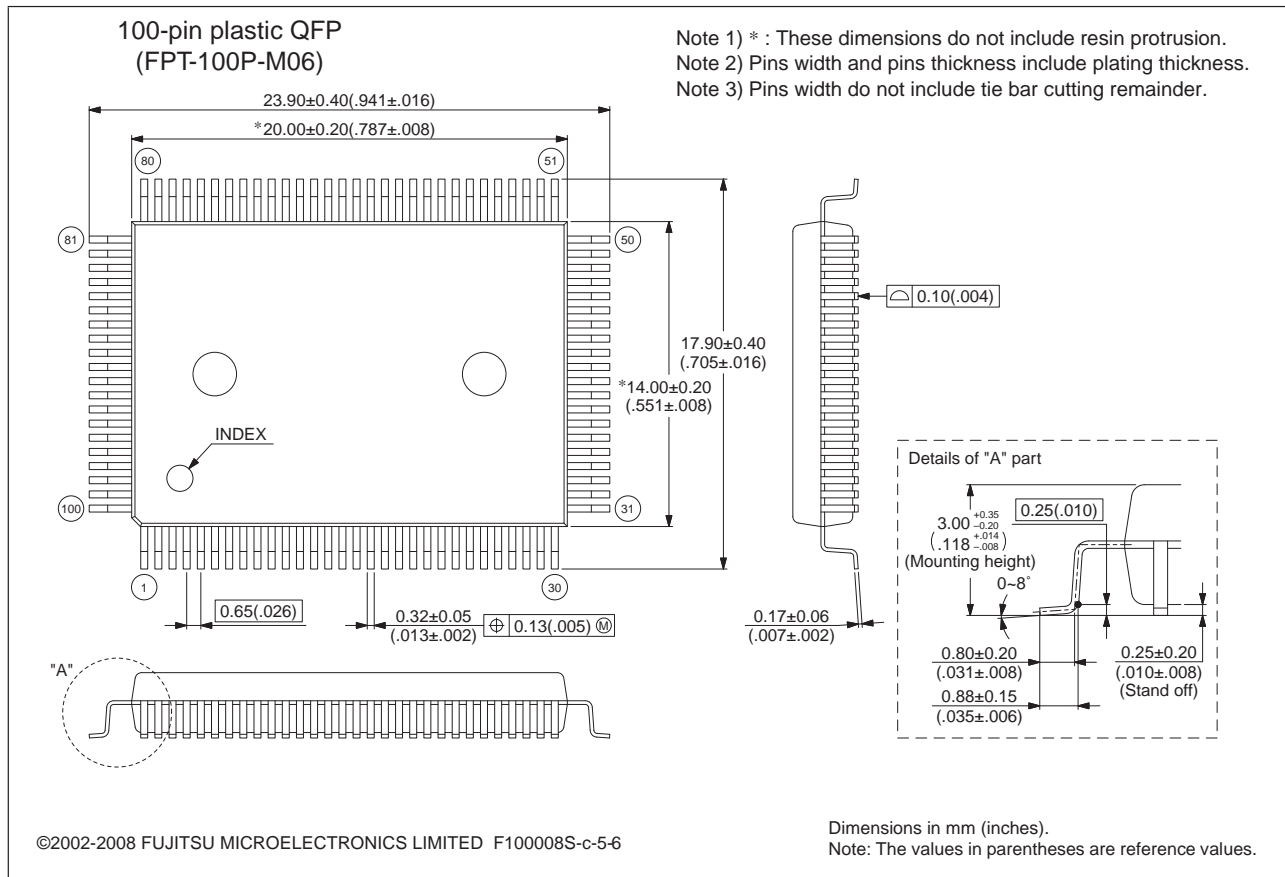

Please check the latest Package dimension at the following URL.
<http://edevice.fujitsu.com/package/en-search/>

MB90800 Series

■ MAIN CHANGES IN THIS EDITION

Page	Section	Change Results
17	■ MEMORY MAP	Corrected "Address #2" for part number MB90F809/S. FC8000 _H → FD0000 _H

The vertical lines marked in the left side of the page show the changes.

MEMO

MEMO

MEMO

MB90800 Series

FUJITSU MICROELECTRONICS LIMITED

Shinjuku Dai-Ichi Seimei Bldg., 7-1, Nishishinjuku 2-chome,
Shinjuku-ku, Tokyo 163-0722, Japan
Tel: +81-3-5322-3329
<http://jp.fujitsu.com/fml/en/>

For further information please contact:

North and South America

FUJITSU MICROELECTRONICS AMERICA, INC.
1250 E. Arques Avenue, M/S 333
Sunnyvale, CA 94085-5401, U.S.A.
Tel: +1-408-737-5600 Fax: +1-408-737-5999
<http://www.fma.fujitsu.com/>

Asia Pacific

FUJITSU MICROELECTRONICS ASIA PTE. LTD.
151 Lorong Chuan,
#05-08 New Tech Park 556741 Singapore
Tel : +65-6281-0770 Fax : +65-6281-0220
<http://www.fmal.fujitsu.com/>

Europe

FUJITSU MICROELECTRONICS EUROPE GmbH
Pittlerstrasse 47, 63225 Langen, Germany
Tel: +49-6103-690-0 Fax: +49-6103-690-122
<http://emea.fujitsu.com/microelectronics/>

FUJITSU MICROELECTRONICS SHANGHAI CO., LTD.

Rm. 3102, Bund Center, No.222 Yan An Road (E),
Shanghai 200002, China
Tel : +86-21-6146-3688 Fax : +86-21-6335-1605
<http://cn.fujitsu.com/fmc/>

Korea

FUJITSU MICROELECTRONICS KOREA LTD.
206 Kosmo Tower Building, 1002 Daechi-Dong,
Gangnam-Gu, Seoul 135-280, Republic of Korea
Tel: +82-2-3484-7100 Fax: +82-2-3484-7111
<http://kr.fujitsu.com/fmk/>

FUJITSU MICROELECTRONICS PACIFIC ASIA LTD.

10/F., World Commerce Centre, 11 Canton Road,
Tsimshatsui, Kowloon, Hong Kong
Tel : +852-2377-0226 Fax : +852-2376-3269
<http://cn.fujitsu.com/fmc/en/>

Specifications are subject to change without notice. For further information please contact each office.

All Rights Reserved.

The contents of this document are subject to change without notice.

Customers are advised to consult with sales representatives before ordering.

The information, such as descriptions of function and application circuit examples, in this document are presented solely for the purpose of reference to show examples of operations and uses of FUJITSU MICROELECTRONICS device; FUJITSU MICROELECTRONICS does not warrant proper operation of the device with respect to use based on such information. When you develop equipment incorporating the device based on such information, you must assume any responsibility arising out of such use of the information.

FUJITSU MICROELECTRONICS assumes no liability for any damages whatsoever arising out of the use of the information.

Any information in this document, including descriptions of function and schematic diagrams, shall not be construed as license of the use or exercise of any intellectual property right, such as patent right or copyright, or any other right of FUJITSU MICROELECTRONICS or any third party or does FUJITSU MICROELECTRONICS warrant non-infringement of any third-party's intellectual property right or other right by using such information. FUJITSU MICROELECTRONICS assumes no liability for any infringement of the intellectual property rights or other rights of third parties which would result from the use of information contained herein.

The products described in this document are designed, developed and manufactured as contemplated for general use, including without limitation, ordinary industrial use, general office use, personal use, and household use, but are not designed, developed and manufactured as contemplated (1) for use accompanying fatal risks or dangers that, unless extremely high safety is secured, could have a serious effect to the public, and could lead directly to death, personal injury, severe physical damage or other loss (i.e., nuclear reaction control in nuclear facility, aircraft flight control, air traffic control, mass transport control, medical life support system, missile launch control in weapon system), or (2) for use requiring extremely high reliability (i.e., submersible repeater and artificial satellite).

Please note that FUJITSU MICROELECTRONICS will not be liable against you and/or any third party for any claims or damages arising in connection with above-mentioned uses of the products.

Any semiconductor devices have an inherent chance of failure. You must protect against injury, damage or loss from such failures by incorporating safety design measures into your facility and equipment such as redundancy, fire protection, and prevention of over-current levels and other abnormal operating conditions.

Exportation/release of any products described in this document may require necessary procedures in accordance with the regulations of the Foreign Exchange and Foreign Trade Control Law of Japan and/or US export control laws.

The company names and brand names herein are the trademarks or registered trademarks of their respective owners.