

16-bit Proprietary Microcontroller

CMOS

F²MC-16LX MB90440G Series

MB90443G/F443G/V440G

■ DESCRIPTION

The MB90440G series with FULL-CAN and FLASH ROM is a line of general-purpose, Fujitsu Microelectronics 16-bit microcontrollers specially designed for automotive and industrial applications. Its main features are three on board CAN Interfaces (generic type) , which conform to V2.0 Part A and Part B, supporting very flexible message buffering. Thus, more functions than a normal full CAN approach is available.

While inheriting the AT architecture of the F²MC* family, the instruction set for the F²MC-16LX CPU core incorporates additional instructions for high-level languages, supports extended addressing modes, and contains enhanced multiplication and division instructions as well as a substantial collection of improved bit manipulation instructions. In addition, the MB90440G series has as on-chip 32-bit accumulator, which enables processing of long-word data.

The peripheral resources integrated in the MB90440G series include; an 8/10-bit A/D converter, UARTs (SCI) , I/O extended serial interface, 8/16-bit PPG timer, input/output timer (input capture (ICU) , output compare (OCU)) .

* : F²MC is the abbreviation of FUJITSU Flexible Microcontroller.

For the information for microcontroller supports, see the following web site.

<http://edevic.fujitsu.com/micom/en-support/>

MB90440G Series

■ FEATURES

• Clock

Internal PLL clock multiplication circuit
Base oscillation divided into two or multiplied by one to four
Minimum execution time : 62.5 ns (4 MHz oscillation, PLL clock multiplication multiplier = 4, $V_{CC} = 5.0$ V)
32 kHz subsystem clock

• Instruction set optimized for controller applications

Supported data types : bit, byte, word, and long-word types
Standard addressing modes : 23 types
Signed multiplication/division and extended RET1 instructions
32-bit accumulator enhancing high-precision operations

• Enhanced high level language (C) and multi-tasking support instructions

Use of a system stack pointer
Symmetrical instruction set and barrel shift instructions

• Program patch function (for two address pointers)

• Enhanced execution speed : 4 byte instruction queue

• Enhanced interrupt function : 8 priority levels programmable and 34 causes

• Automatic data transmission function independent of CPU operation

Extended intelligent I/O service function (EI²OS)

• Internal ROM size and type

FLASH ROM : 128 Kbytes
Internal RAM size : 6 Kbyte and 14 Kbyte (evaluation chip)

• FLASH ROM

Supports automatic programming function, Embedded Algorithm
Writing command/erase command/erase suspend and resume command
Algorithms completion flag
Hardwire reset vector to show the fixed boot code sector
Can be erased by each sector
Sector protection by external programming voltage

• Low-power consumption (stand-by) modes

Sleep mode (CPU operating clock stops)
Stop mode (Main oscillation stops)
CPU intermittent operation mode
Watch mode
Time-base timer mode

• General-purpose I/O ports : 81 ports

• Timers

Watchdog timer : 1 channel
8/16-bit PPG timer : 8/16-bit \times 4 channels
16-bit reload timer : 2 channels

(Continued)

(Continued)

- **16-bit I/O timers**

- 16-bit free-run timers : 1 channel
 - 16-bit input capture : 8 channels
 - 16-bit output compare : 4 channels

- **Extended I/O serial interfaces : 1 channel**

- **UART0**

- Full-duplex, double-buffered (8 bit)
 - Can be used for clock synchronous and asynchronous transfer (with start/stop bit)

- **UART1 (SCI)**

- Full-duplex, double-buffered (8 bit)
 - Can be used for clock synchronous and asynchronous serial transfer (extended I/O serial)

- **External interrupt inputs : 8 channels**

- Extended intelligent I/O service (EI²OS) is started by external input and external interrupt generation module

- **Delayed interrupt generation module : interrupt request for task switching**

- **8/10 bit A/D converter : 8 channels**

- 8/10-bit resolution selectable
 - Can be started by external trigger input
 - Conversion time : 6.12 μ s

- **FULL-CAN interface**

- 3 channels
 - Conform to V2.0 Part A and Part B
 - Supports very flexible message buffering (mail-box and FIFO buffering can be mixed)

- **External bus interface : maximum 16 Mbyte address space**

MB90440G Series

■ PRODUCT LINEUP

The following table provides a quick outlook of the MB90440G Series

Part number Parameter	MB90443G (under development)	MB90F443G	MB90V440G
CPU	F ² MC-16LX CPU		
System clock	On-chip PLL clock multiplier (×1, ×2, ×3, ×4, 1/2 when PLL stops) Minimum instruction execution time : 62.5 ns (4 MHz osc. PLL ×4)		
ROM size	Mask ROM 128 Kbytes	Flash memory 128 Kbytes	External
RAM size	6 Kbytes	6 Kbytes	14 Kbytes
Operating ¹ voltage range	5 V ± 10%		
Temperature range	-40 °C to +105 °C		
Package	QFP100		PGA-256
Voltage dedicated for emulator ²	—		No
UART0	Full duplex double buffer Supports clock asynchronous/synchronous (with start/stop bits) transfer Baud rate : 4808/5208/9615/10417/19230/38460/62500/500000 bps (asynchronous) 500 K/1 M/2 Mbps (synchronous) at System clock = 16 MHz		
UART1 (SCI)	Full duplex double buffer Asynchronized (start/stop bits synchronized) and CLK-synchronous communication Baud rate : 601 bps to 250 kbps (asynchronous) 31.25 kbps to 2 Mbps (synchronous)		
Serial IO	Transfer can be started from MSB or LSB Supports internal clock synchronized transfer and external clock synchronized transfer Supports positive-edge and negative-edge clock synchronization Baud rate : 31.25 K/62.5 K/125 K/500 K/1 M/2 Mbps at System clock = 16 MHz		
8/10 bit A/D Converter	10-bit or 8-bit resolution 8 input channels Conversion time : 6.12 μs (per one channel)		
16-bit Reload Timer (2 channels)	Operation clock frequency : $f_{sys}/2^1$, $f_{sys}/2^3$, $f_{sys}/2^5$ (f_{sys} = System clock frequency) Supports External Event Count function		
16-bit Free-run Timer	Signals an interrupt during overflow Supports Timer Clear during a match with Output Compare (Channel 0) Operation clock freq. : $f_{sys}/2^2$, $f_{sys}/2^4$, $f_{sys}/2^6$, $f_{sys}/2^8$ (f_{sys} = System clock freq.)		
16-bit Output Compare (4 channels)	Signals an interrupt during a match with 16-bit Free-run Timer Four 16-bit compare registers A pair of compare registers can be used to generate an output signal		

(Continued)

MB90440G Series

(Continued)

Part number Parameter	MB90443G (under development)	MB90F443G	MB90V440G
16-bit Input Capture (8 channels)	Rising edge, falling edge or rising & falling edge sensitive Four 16-bit capture registers Signals an interrupt upon external event		
8/16-bit Programmable Pulse Generator (4 channels)	Supports 8-bit and 16-bit operation modes Eight 8-bit reload counters Eight 8-bit reload registers for L pulse width Eight 8-bit reload registers for H pulse width A pair of 8-bit reload counters can be configured as one 16-bit reload counter or as 8-bit prescaler plus 8-bit reload counter 4 output pins Operation clock frequency. : f_{sys} , $f_{sys}/2^1$, $f_{sys}/2^2$, $f_{sys}/2^3$, $f_{sys}/2^4$ or $128 \mu s @ f_{osc} = 4 \text{ MHz}$ (f_{sys} = System clock frequency, f_{osc} = Oscillation clock frequency)		
CAN Interface 3 channels :	Conforms to CAN Specification Version 2.0 Part A and B Automatic re-transmission in case of error Automatic transmission responding to Remote Frame Supports prioritized 16 message buffers for data and ID Flexible configuration of acceptance filtering : Full bit compare / Full bit mask / Two partial bit masks Supports up to 1 Mbps		
External Interrupt (8 channels)	Can be programmed edge detection or level detection		
External bus interface	The external access used selective 8-bit bus or 16-bit bus is available. (External bus mode)		
I/O Ports	Virtually all external pins can be used as general purpose I/O All push-pull outputs and schmitt trigger inputs Bit-wise programmable as input/output or peripheral signal		
32 kHz Subclock	Sub-clock for low power operation		
Flash Memory	Supports automatic programming, Embedded Algorithm Write/Erase/Erase-Suspend/Resume commands A flag indicating completion of the algorithm Number of erase cycles : 10,000 times Data retention time : 10 years Boot block configuration Erase can be performed on each block Block protection with external programming voltage		

*1 : Values with conditions such as the operating frequency (See section “■ ELECTRICAL CHARACTERISTICS”).

*2 : DIP switch S2 when using emulation pad MB2145-507.

The details are referred to hardware manual of MB2145-507.

MB90440G Series

■ PIN ASSIGNMENT

(TOP VIEW)

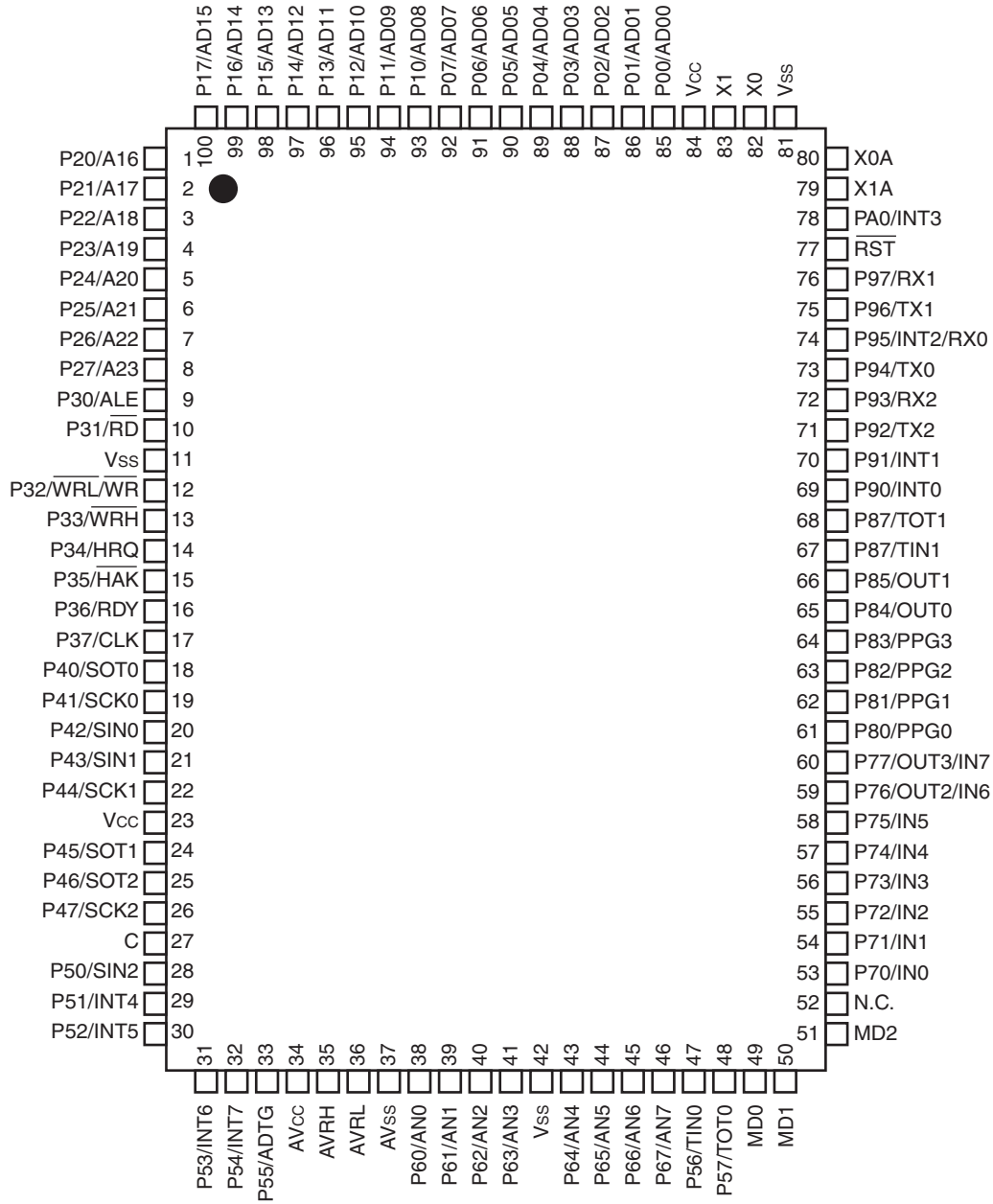

(FPT-100P-M06)

■ PIN DESCRIPTION

Pin No.	Pin name	Circuit type	Function
82 83	X0 X1	A (Oscillation)	High speed oscillator input pins
80 79	X0A X1A	A (Oscillation)	Low speed oscillator input pins
77	\overline{RST}	B	External reset request input
52	N.C.	—	not connected
85 to 92	P00 to P07	H	General I/O port with programmable pullup. This function is enabled in the single-chip mode.
	AD00 to AD07		I/O pins for 8 lower bits of the external address/data bus. This function is enabled when the external bus is enabled.
93 to 100	P10 to P17	H	General I/O port with programmable pullup. This function is enabled in the single-chip mode.
	AD08 to AD15		I/O pins for 8 higher bits of the external address/data bus. This function is enabled when the external bus is enabled.
1 to 8	P20 to P27	H	General I/O port with programmable pullup. This function is enabled in the single-chip mode.
	A16 to A23		I/O pins of 8 bits for A16 to A23 of the external address bus. This function is enabled when the external bus is enabled.
9	P30	H	General I/O port with programmable pullup. This function is enabled in the single-chip mode.
	ALE		Address latch enable output pin. This function is enabled when the external bus is enabled.
10	P31	H	General I/O port with programmable pullup. This function is enabled in the single-chip mode.
	\overline{RD}		Read strobe output pin for the data bus. This function is enabled when the external bus is enabled.
12	P32	H	General I/O port with programmable pullup. This function is enabled in the single-chip mode or when the $\overline{WR}/\overline{WRL}$ pin output is disabled.
	\overline{WRL}		Write strobe output pin for the data bus. This function is enabled when the external bus is in enable mode and the $\overline{WR}/\overline{WRL}$ pin output is enabled. \overline{WRL} is used as a write-strobe output pin for 8 lower bits of the data bus in 16-bit access while \overline{WR} is used as a write-strobe output pin for 8 bits of the data bus in 8-bit access.
	\overline{WR}		
13	P33	H	General I/O port with programmable pullup. This function is enabled in the single-chip mode or external bus 8-bit mode or when \overline{WRH} pin output is disabled.
	\overline{WRH}		Write strobe output pin for the 8 higher bits of the data bus. This function is enabled when the external bus is enabled, when the external bus 16-bit mode is selected, and when the \overline{WRH} output pin is enabled.

(Continued)

MB90440G Series

Pin No.	Pin name	Circuit type	Function
14	P34	H	General I/O port with programmable pullup. This function is enabled in the single-chip mode or when hold function is disabled.
	HRQ		Hold request input pin. This function is enabled when the external bus is in enable mode and the hold function is enabled.
15	P35	H	General I/O port with programmable pullup. This function is enabled in the single-chip mode or when hold function is disabled.
	$\overline{\text{HAK}}$		Hold acknowledge output pin. This function is enabled when the external bus is in enable mode and the hold function is enabled.
16	P36	H	General I/O port with programmable pullup. This function is enabled in the single-chip mode or when the external ready function is disabled.
	RDY		Ready input pin. This function is enabled when the external bus is in enable mode and the external ready function is enabled.
17	P37	H	General I/O port with programmable pullup. This function is enabled in the single-chip mode or when CLK output is disabled.
	CLK		CLK output pin. This function is enabled when the external bus is in enable mode and CLK output is enabled.
18	P40	G	General I/O port. This function is enabled when serial data output of UART0 is disabled.
	SOT0		Serial data output pin for UART0. This function is enabled when UART0 enables serial data output.
19	P41	G	General I/O port. This function is enabled when clock output of UART0 is disabled.
	SCK0		Serial clock I/O pin for UART0. This function is enabled when UART0 enables serial clock output.
20	P42	G	General I/O port. This function is always enabled.
	SIN0		Serial data input pin for UART0. Set the corresponding DDR register to input if this function is used.
21	P43	G	General I/O port. This function is always enabled.
	SIN1		Serial data input pin for UART1. Set the corresponding DDR register to input if this function is used.
22	P44	G	General I/O port. This function is enabled when serial clock output of UART1 is disabled.
	SCK1		Serial clock I/O pin for UART1. This function is enabled when UART1 enables serial clock output.
24	P45	G	General I/O port. This function is enabled when serial data output of UART1 is disabled.
	SOT1		Serial data output pin for UART1. This function is enabled when UART1 enables serial data output.

(Continued)

Pin No.	Pin name	Circuit type	Function
25	P46	G	General I/O port. This function is enabled when the extended serial I/O interface disables serial data output.
	SOT2		Serial data output pin for the extended serial I/O interface. This function is enabled when the extended serial I/O interface enables serial data output.
26	P47	G	General I/O port. This function is enabled when the extended serial I/O interface disables serial clock output.
	SCK2		Serial clock I/O pin for the extended serial I/O interface. This function is enabled when the extended serial I/O interface enables serial clock output.
28	P50	D	General I/O port. This function is always enabled.
	SIN2		Serial data input pin for the extended serial I/O interface. Set the corresponding DDR register to input if this function is used.
29 to 32	P51 to P54	D	General I/O ports. This function is always enabled.
	INT4 to INT7		External interrupt request input pins for INT4 to INT7. Set the corresponding DDR register to input if this function is used.
33	P55	D	General I/O port. This function is always enabled.
	ADTG		External trigger input pin for the 8/10-bit A/D converter. Set the corresponding DDR register to input if this function is used.
38 to 41	P60 to P63	E	General I/O ports. The function is enabled when the analog input enable register specifies port.
	AN0 to AN3		Analog input pins for the 8/10-bit A/D converter. This function is enabled when the analog input enable register specifies A/D.
43 to 46	P64 to P67	E	General I/O ports. The function is enabled when the analog input enable register specifies port.
	AN4 to AN7		Analog input pins for the 8/10-bit A/D converter. This function is enabled when the analog input enable register specifies A/D.
47	P56	D	General I/O port. This function is always enabled.
	TIN0		Event input pin for the 16-bit reload timers 0. Set the corresponding DDR register to input if this function is used.
48	P57	D	General I/O port. This function is enabled when the 16-bit reload timers 0 disables output.
	TOT0		Output pin for the 16-bit reload timers 0. This function is enabled when the 16-bit reload timers 0 enables output.
53 to 58	P70 to P75	D	General I/O ports. This function is always enabled.
	IN0 to IN5		Trigger input pins for input captures ICU0 to ICU5. Set the corresponding DDR register to input if this function is used.

(Continued)

MB90440G Series

Pin No.	Pin name	Circuit type	Function
59 to 60	P76 to P77	D	General I/O ports. This function is enabled when the OCU disables output.
	OUT2 to OUT3		Event output pins for output compares OCU2 and OCU3. This function is enabled when the OCU enables output.
	IN6 to IN7		Trigger input pins for input captures ICU6 and ICU7. Set the corresponding DDR register to input and prohibit the OCU output if this function is used.
61 to 64	P80 to P83	D	General I/O ports. This function is enabled when 8/16-bit PPG timer disables waveform output.
	PPG0 to PPG3		Output pins for 8/16-bit PPG timer. This function is enabled when 8/16-bit PPG timer enables waveform output.
65 to 66	P84 to P85	D	General I/O ports. This function is enabled when the OCU disables output.
	OUT0 to OUT1		Event output pins for output compares OCU0 and OCU1. This function is enabled when the OCU enables output.
67	P86	D	General I/O port. This function is always enabled.
	TIN1		Input pin for the 16-bit reload timers 1. Set the corresponding DDR register to input if this function is used.
68	P87	D	General I/O port. This function is enabled when the 16-bit reload timers 0 disables output.
	TOT1		Output pin for the 16-bit reload timers 1. This function is enabled when the reload timers 1 enables output.
69 to 70	P90 to P91	D	General I/O ports. This function is always enabled.
	INT0 to INT1		External interrupt request input pins for INT0 to INT3. Set the corresponding DDR register to input if this function is used.
71	P92	D	General I/O port. This function is enabled when CAN2 disables output.
	TX2		TX output pin for CAN2. This function is enabled when CAN2 enables output.
72	P93	D	General I/O port. This function is always enabled.
	RX2		RX input pin for CAN2 interface. When the CAN function is used, output from the other functions must be stopped.
73	P94	D	General I/O port. This function is enabled when CAN0 disables output.
	TX0		TX output pin for CAN0. This function is enabled when CAN0 enables output.
74	P95	D	General I/O port. This function is always enabled.
	INT2		External interrupt request input pin for INT2. Set the corresponding DDR register to input if this function is used.
	RX0		RX input pin for CAN0 interface. When the CAN function is used, output from the other functions must be stopped.

(Continued)

(Continued)

Pin No.	Pin name	Circuit type	Function
75	P96	D	General I/O port. This function is enabled when CAN1 disables output.
	TX1		TX output pin for CAN1. This function is enabled when CAN1 enables output.
76	P97	D	General I/O port. This function is always enabled.
	RX1		RX input pin for CAN1 interface. When the CAN function is used, output from the other functions must be stopped.
78	PA0	D	General I/O port. This function is always enabled.
	INT3		External interrupt request input pin for INT2. Set the corresponding DDR register to input if this function is used.
34	AV _{CC}	Power supply	Power supply pin for the A/D Converter. This power supply must be turned on or off while a voltage higher than or equal to AV _{CC} is applied to V _{CC} .
37	AV _{SS}	Power supply	Dedicated ground pin for the A/D Converter
35	AVRH	Power supply	External reference voltage pin for the A/D Converter. This power supply must be turned on or off while a voltage higher than or equal to AVRH is applied to AV _{CC} .
36	AVRL	Power supply	External reference voltage pin for the A/D Converter
49 to 50	MD0 to MD1	C	Input pins for specifying the operating mode. The pins must be directly connected to V _{CC} or V _{SS} .
51	MD2	F	Input pin for specifying the operating mode. The pin must be directly connected to V _{CC} or V _{SS} .
27	C	—	This is the power supply stabilization capacitor pin. It should be connected externally to an 0.1 μF ceramic capacitor.
23, 84	V _{CC}	Power supply	Voltage (5.0 V) input pin
11, 42, 81	V _{SS}	Power supply	Voltage (0.0 V) input pin



■ INPUT LEVELS

The input level of ports P00 to P37 can be selected to be either TTL- or CMOS - level. The initial setting is TTL - level. These settings are global for all P00 to P37, it is not possible to set different levels to each port.

The input level of ports P40 to PA0 can be selected to be either CMOS- or AUTOMOTIVE - level. The initial setting is CMOS - level. This settings can be done for each port individually.

MB90440G Series

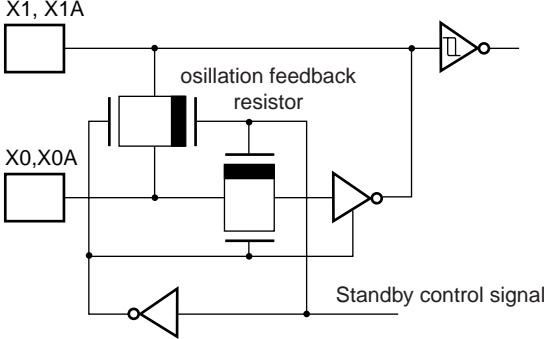
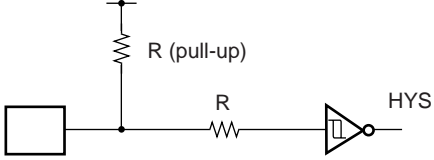
■ I/O CIRCUIT TYPE

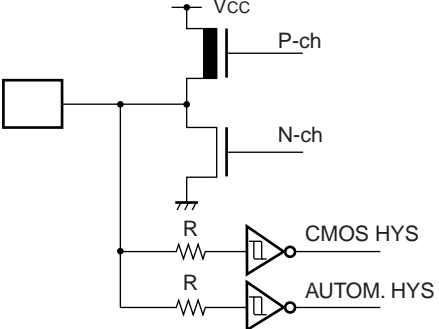
Circuit type	Circuit	Remarks
A	 <p>The diagram shows an oscillator circuit. It includes two crystal resonators labeled X1, X1A and X0, X0A. An oscillation feedback resistor is connected between the two resonators. A standby control signal is connected to the circuit through an inverter.</p>	<ul style="list-style-type: none"> Oscillation feedback resistor : 1 MΩ approx. (High speed oscillator) 10MΩ approx. (Low speed oscillator)
B	 <p>The diagram shows a pull-up resistor R connected to Vcc. The input of a hysteresis input (HYS) is connected to the input of an inverter through a resistor R.</p>	<ul style="list-style-type: none"> CMOS hysteresis input . Pull-up resistor : 50 kΩ approx.
C	 <p>The diagram shows a resistor R connected to the input of a hysteresis input (HYS).</p>	<ul style="list-style-type: none"> Hysteresis input
D	 <p>The diagram shows a CMOS level output circuit. It includes a P-channel MOSFET (P-ch) and an N-channel MOSFET (N-ch). The input is connected to the gates of both transistors. The output is taken from the drain of the P-ch MOSFET. Two resistors R are connected to the input, one leading to a CMOS HYS input and the other to an AUTOM. HYS input.</p>	<ul style="list-style-type: none"> CMOS level output CMOS hysteresis input Automotive hysteresis input (See "■ INPUT LEVELS".)

(Continued)

Circuit type	Circuit	Remarks
E		<ul style="list-style-type: none"> • CMOS level output • CMOS hysteresis input • Automotive hysteresis input (See "■ INPUT LEVELS".) • Analog input
F		<ul style="list-style-type: none"> • CMOS hysteresis input • Pull-down resistor : 50 kΩ approx. (except FLASH devices)
G		<ul style="list-style-type: none"> • CMOS level output • CMOS hysteresis input • Automotive hysteresis input (See "■ INPUT LEVELS".) • TTL input (FLASH devices in flash write mode only)

(Continued)

MB90440G Series

(Continued)

Circuit type	Circuit	Remarks
H		<ul style="list-style-type: none"> • CMOS level output • CMOS hysteresis input • TTL hysteresis input (See "■ INPUT LEVELS".) • Programmable pullup resistor : 50 kΩ approx.

■ HANDLING DEVICES

1. Preventing Latch-up

CMOS IC chips may suffer latch-up under the following conditions :

- (1) A voltage higher than V_{CC} or lower than V_{SS} is applied to an input or output pin.
- (2) A voltage higher than the rated voltage is applied to between V_{CC} and V_{SS} .
- (3) The AV_{CC} power supply is applied before the V_{CC} voltage.

Latch-up may increase the power supply current drastically, causing thermal damage to the device.

Always take sufficient precautions in using semiconductor devices to avoid this possibility.

Also be careful not to let the analog power-supply voltage (AV_{CC} , AV_{RH}) exceed the digital power-supply voltage (V_{CC}) when the analog system power-supply is turned on and off.

2. Handling Unused Input Pins

Do not leave unused input pins open, as doing so may cause misoperation of the device or latch-up leading to permanent damage. Unused input pins should be pulled up or pulled down through at least 2 k Ω resistance.

Unused I/O pins may be left open in output state, but if such pins are in input state they should be handled in the same way as input pins.

3. Use of the External Clock

To use the external clock, drive only the X0 pin and leave the X1 pin open.

A diagram of how to use an external clock is shown below.

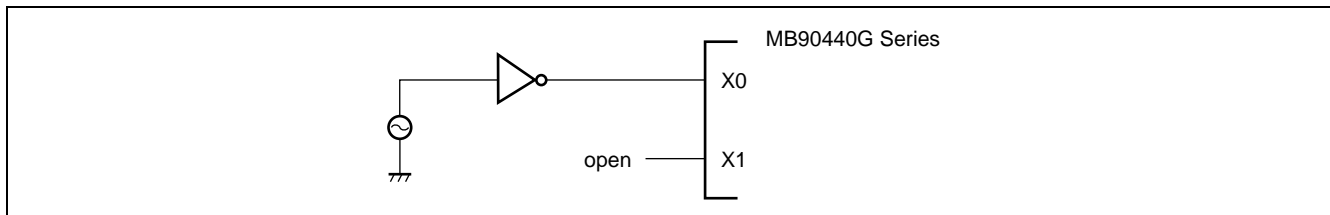

4. Precautions for when not using a Sub Clock Signal

If the X0A and X1A pins are not connected to an oscillator, apply pull-down treatment to the X0A pin and leave the X1A pin open.

5. Power Supply Pins (V_{CC}/V_{SS})

In products with multiple V_{CC} or V_{SS} pins, the pins of a same potential are internally connected in the device to avoid abnormal operations including latch-up. However, connect the pins external power and ground lines to lower the electro-magnetic emission level to prevent abnormal operation of strobe signals caused by the rise in the ground level, and to conform to the total current rating.

Make sure to connect V_{CC} and V_{SS} pins via lowest impedance to power lines.

It is recommended to provide a bypass capacitor of around 0.1 μF between V_{CC} and V_{SS} pins near the device.

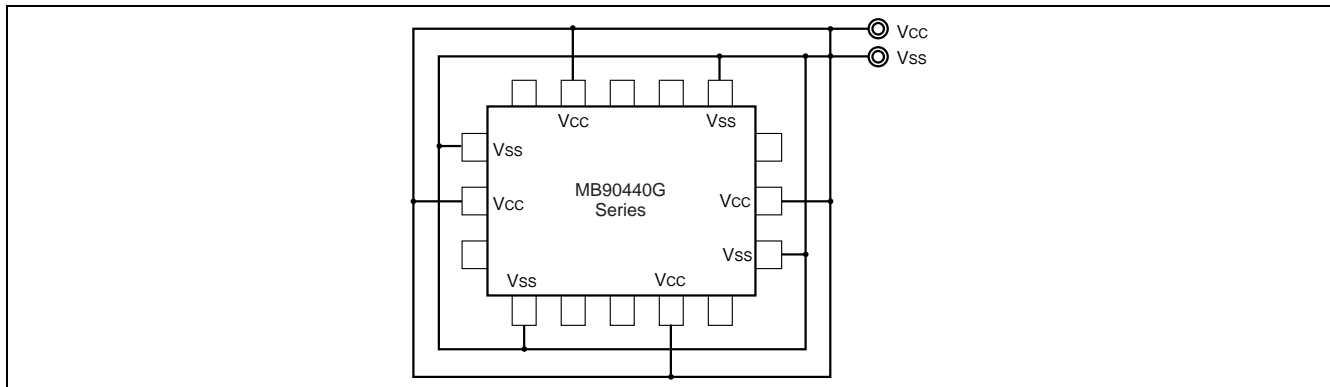

6. Pull-up/down resistors

The MB90440G Series does not support internal pull-up/down resistors (except pull-up resistors of port 0 to port 3) . Use external components needed.

7. Crystal Oscillator Circuit

Noises around X0 or X1 pins may cause abnormal operations. Make sure to provide bypass capacitors via the shortest distances from X0 and X1 pins, crystal oscillator (or ceramic resonator) and ground lines, and make sure, to the utmost effort, that lines of oscillation circuits do not cross the lines of other circuits.

It is highly recommended to provide a printed circuit board artwork surrounding X0 and X1 pins with a ground area for stabilizing the operation.

8. Turning-on Sequence of Power Supply to A/D Converter and Analog Inputs

Make sure to turn on the A/D and D/A converters power supply (AV_{CC} , $AVRH$, $AVRL$) and analog inputs (AN0 to AN7) after turning on the digital power supply (V_{CC}) .

Turn off the digital power after turning off the A/D converter supply and analog inputs. In this case, make sure that $AVRH$ does not exceed AV_{CC} (turning on/off the analog and digital power supplies simultaneously is acceptable) .

9. Connection of Unused Pins of A/D Converter

Connect unused pins of A/D and D/A converters to $AV_{CC} = V_{CC}$, $AV_{SS} = AVRH = V_{SS}$.

10. N.C. Pin

The N.C. (internally connected) pin must be opened for use.

11. Notes on Energization

To prevent the internal regulator circuit from malfunctioning, set the voltage rise time during energization at 50 μ s or more (0.2 V to 2.7 V) .

12. Initialization

In the device, there are internal registers which are initialized only by a power-on reset. To initialize these registers, please turn on the power again.

13. Using REALOS

The use of (EI²OS) is not possible with the REALOS real time operation system.

14. Caution on Operations during PLL Clock Mode

If the PLL clock mode is selected in the microcontroller, it may attempt to continue the operation using the free-running frequency of the automatic oscillating circuit in the PLL circuitry even if the oscillator is out of place or the clock input is stopped. Performance of this operation, however, cannot be guaranteed.

■ BLOCK DIAGRAM

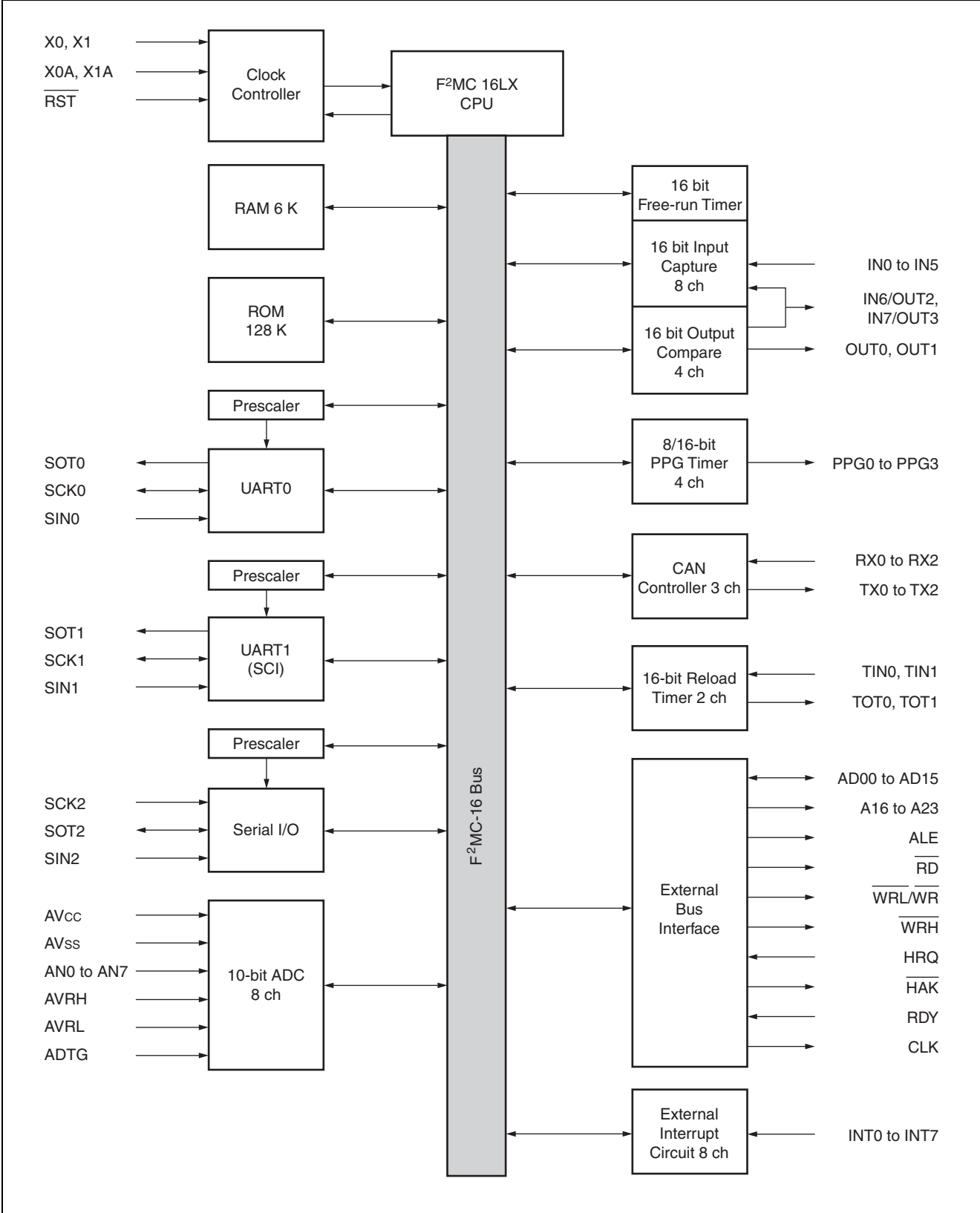

MB90440G Series

MEMORY MAP

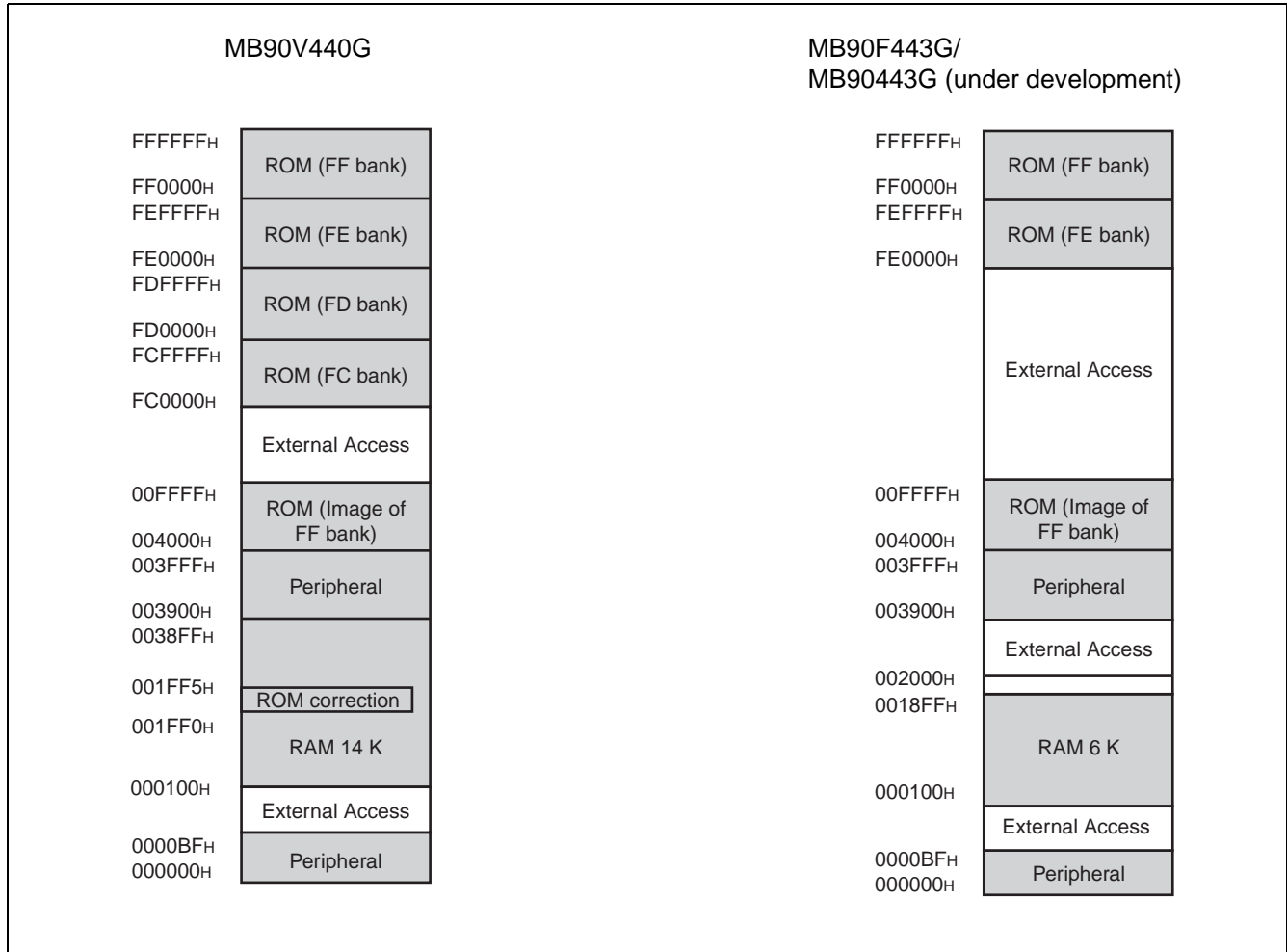

Note : The high-order portion of bank 00 gives the image of the FF bank ROM to make the small model of the C compiler effective. Since the low-order 16 bits are the same address, the table in ROM can be referenced without using the far specification in the pointer declaration.

For example, an attempt to access 00C000H accesses the value at FFC000H in ROM.

The ROM area in bank FF exceeds 48 Kbytes, and its entire image cannot be shown in bank 00.

The image between FF4000H and FFFFFFFH is visible in bank 00, while the image between FF4000H and FFFFFFFH is visible only in bank FF. Thus, it is recommended that the ROM data table be stored in the area of FF4000H and FFFFFFFH .

■ I/O MAP

Address	Register	Abbreviation	Read/Write	Resource name	Initial value
00 _H	Port 0 data register	PDR0	R/W	Port 0	XXXXXXXX _B
01 _H	Port 1 data register	PDR1	R/W	Port 1	XXXXXXXX _B
02 _H	Port 2 data register	PDR2	R/W	Port 2	XXXXXXXX _B
03 _H	Port 3 data register	PDR3	R/W	Port 3	XXXXXXXX _B
04 _H	Port 4 data register	PDR4	R/W	Port 4	XXXXXXXX _B
05 _H	Port 5 data register	PDR5	R/W	Port 5	XXXXXXXX _B
06 _H	Port 6 data register	PDR6	R/W	Port 6	XXXXXXXX _B
07 _H	Port 7 data register	PDR7	R/W	Port 7	XXXXXXXX _B
08 _H	Port 8 data register	PDR8	R/W	Port 8	XXXXXXXX _B
09 _H	Port 9 data register	PDR9	R/W	Port 9	XXXXXXXX _B
0A _H	Port A data register	PDRA	R/W	Port A	_____X _B
0B _H	Port input levels select register	PILR	R/W	Ports	00000000 _B
0C _H	CAN2 RX/TX pin switching register	CANSWR	R/W	CAN1/2	_____00 _B
0D _H to 0F _H	Reserved				
10 _H	Port 0 direction register	DDR0	R/W	Port 0	00000000 _B
11 _H	Port 1 direction register	DDR1	R/W	Port 1	00000000 _B
12 _H	Port 2 direction register	DDR2	R/W	Port 2	00000000 _B
13 _H	Port 3 direction register	DDR3	R/W	Port 3	00000000 _B
14 _H	Port 4 direction register	DDR4	R/W	Port 4	00000000 _B
15 _H	Port 5 direction register	DDR5	R/W	Port 5	00000000 _B
16 _H	Port 6 direction register	DDR6	R/W	Port 6	00000000 _B
17 _H	Port 7 direction register	DDR7	R/W	Port 7	00000000 _B
18 _H	Port 8 direction register	DDR8	R/W	Port 8	00000000 _B
19 _H	Port 9 direction register	DDR9	R/W	Port 9	00000000 _B
1A _H	Port A direction register	DDRA	R/W	Port A	_____0 _B
1B _H	Analog input enable register	ADER	R/W	Port 6, A/D	11111111 _B
1C _H	Port 0 pullup control register	PUCR0	R/W	Port 0	00000000 _B
1D _H	Port 1 pullup control register	PUCR1	R/W	Port 1	00000000 _B
1E _H	Port 2 pullup control register	PUCR2	R/W	Port 2	00000000 _B
1F _H	Port 3 pullup control register	PUCR3	R/W	Port 3	00000000 _B
20 _H	Serial mode control register 0	UMC0	R/W	UART0	00000100 _B
21 _H	Serial status register 0	USR0	R/W		00010000 _B
22 _H	Serial input/output data register 0	UIDR0/UODR0	R/W		XXXXXXXX _B
23 _H	Rate and data register 0	URD0	R/W		0000000X _B

(Continued)

MB90440G Series

Address	Register	Abbreviation	Read/Write	Resource name	Initial value
24H	Serial mode register 1	SMR1	R/W	UART1	00000000 _B
25H	Serial control register 1	SCR1	R/W		00000100 _B
26H	Serial input/output data register 1	SIDR1/SODR1	R/W		XXXXXXXX _B
27H	Serial status register 1	SSR1	R/W		00001_00 _B
28H	UART1 prescaler control register	U1CDCR	R/W		0__1111 _B
29H	Serial edge selection register	SES1	R/W		____0 _B
2AH	Reserved				
2BH	Serial I/O prescaler	SCDCR	R/W	Serial I/O	0__1111 _B
2CH	Serial mode control register	SMCS	R/W		____0000 _B
2DH	Serial mode control register	SMCS	R/W		00000010 _B
2EH	Serial Data register	SDR	R/W		XXXXXXXX _B
2FH	Serial edge selection register 2	SES2	R/W		____0 _B
30H	External interrupt enable register	ENIR	R/W	External interrupt circuit	00000000 _B
31H	External interrupt request register	EIRR	R/W		XXXXXXXX _B
32H	External request level setting register	ELVR	R/W		00000000 _B
33H				00000000 _B	
34H	A/D control status register 0	ADCS0	R/W	A/D converter	00000000 _B
35H	A/D control status register 1	ADCS1	R/W		00000000 _B
36H	A/D data register 0	ADCR0	R		XXXXXXXX _B
37H	A/D data register 1	ADCR1	R/W		00001_XX _B
38H	PPG0 operation mode control register	PPGC0	R/W	16-bit Programmable Pulse Generator 0/1	0_000__1 _B
39H	PPG1 operation mode control register	PPGC1	R/W		0_000001 _B
3AH	PPG0 and PPG1 clock selection register	PPG01	R/W		000000__ _B
3BH	Reserved				
3CH	PPG2 operation mode control register	PPGC2	R/W	16-bit Programmable Pulse Generator 2/3	0_000__1 _B
3DH	PPG3 operation mode control register	PPGC3	R/W		0_000001 _B
3EH	PPG2 and PPG3 clock selection register	PPG23	R/W		000000__ _B
3FH	Reserved				
40H	PPG4 operation mode control register	PPGC4	R/W	16-bit Programmable Pulse Generator 4/5	0_000__1 _B
41H	PPG5 operation mode control register	PPGC5	R/W		0_000001 _B
42H	PPG4 and PPG5 clock selection register	PPG45	R/W		000000__ _B
43H	Reserved				

(Continued)

MB90440G Series

Address	Register	Abbrevia- tion	Read/ Write	Resource name	Initial value
44 _H	PPG6 operation mode control register	PPGC6	R/W	16-bit Programable Pulse Generator 6/7	0_000__1 _B
45 _H	PPG7 operation mode control register	PPGC7	R/W		0_000001 _B
46 _H	PPG6 and PPG7 clock selection register	PPG67	R/W		000000__ _B
47 _H to 4B _H	Reserved				
4C _H	Input capture control status 0/1	ICS01	R/W	Input capture 0/1	00000000 _B
4D _H	Input capture control status 2/3	ICS23	R/W	Input capture 2/3	00000000 _B
4E _H	Input capture control status 4/5	ICS45	R/W	Input capture 4/5	00000000 _B
4F _H	Input capture control status 6/7	ICS67	R/W	Input capture 6/7	00000000 _B
50 _H	Timer control status register 0	TMCSR0	R/W	16-bit reload timer 0	00000000 _B
51 _H					____0000 _B
52 _H	Timer register 0/reload register 0	TMR0/ TMRLR0	R/W		XXXXXXXX _B
53 _H					XXXXXXXX _B
54 _H	Timer control status register 1	TMCSR1	R/W	16-bit reload timer 1	00000000 _B
55 _H					____0000 _B
56 _H	Timer register 1/Reload register 1	TMR1/ TMRLR1	R/W		XXXXXXXX _B
57 _H					XXXXXXXX _B
58 _H	Output compare control status register 0	OCS0	R/W	Output compare 0/1	0000__00 _B
59 _H	Output compare control status register 1	OCS1	R/W		__00000 _B
5A _H	Output compare control status register 2	OCS2	R/W	Output compare 2/3	0000__00 _B
5B _H	Output compare control status register 3	OCS3	R/W		__00000 _B
5C _H to 6B _H	Reserved for CAN 2 Interface				
6C _H	Timer data register	TCDT	R/W	I/O timer	00000000 _B
6D _H					00000000 _B
6E _H	Timer control status register	TCCS	R/W		00000000 _B
6F _H	ROM mirror function selection register	ROMM	R/W	ROM mirror function selec- tion module	_____1 _B
70 _H to 7F _H	Reserved for CAN 0 Interface				
80 _H to 8F _H	Reserved for CAN 1 Interface				
90 _H to 9D _H	Prohibited area				
9E _H	Program address detection control status register	PACSR	R/W	Address match detection function	00000000 _B
9F _H	Delayed interrupt/release register	DIRR	R/W	Delayed interrupt genera- tion module	_____0 _B

(Continued)

MB90440G Series

Address	Register	Abbreviation	Read/Write	Resource name	Initial value
A0 _H	Low-power consumption mode control register	LPMCR	R/W	Low power consumption (stand-by) mode	00011000 _B
A1 _H	Clock selection register	CKSCR	R/W	Low power consumption (stand-by) mode	11111100 _B
A2 _H to A4 _H	Prohibited area				
A5 _H	Automatic ready function select register	ARSR	W	External bus pin	0011__00 _B
A6 _H	External address output control register	HACR	W		00000000 _B
A7 _H	Bus control signal selection register	ECSR	W		0000000_ _B
A8 _H	Watchdog timer control register	WDTC	R/W	Watchdog timer	XXXXXX111 _B
A9 _H	Time base timer control register	TBTC	R/W	Time base timer	1- -00100 _B
AA _H	Watch timer control register	WTC	R/W	Watch timer	1X000000 _B
AB _H to AD _H	Prohibited area				
AE _H	Flash memory control status register (Flash only, otherwise reserved)	FMCS	R/W	Flash Memory	000X0000 _B
AF _H	Prohibited area				
B0 _H	Interrupt control register 00	ICR00	R/W	Interrupt controller	00000111 _B
B1 _H	Interrupt control register 01	ICR01	R/W		00000111 _B
B2 _H	Interrupt control register 02	ICR02	R/W		00000111 _B
B3 _H	Interrupt control register 03	ICR03	R/W		00000111 _B
B4 _H	Interrupt control register 04	ICR04	R/W		00000111 _B
B5 _H	Interrupt control register 05	ICR05	R/W		00000111 _B
B6 _H	Interrupt control register 06	ICR06	R/W		00000111 _B
B7 _H	Interrupt control register 07	ICR07	R/W		00000111 _B
B8 _H	Interrupt control register 08	ICR08	R/W		00000111 _B
B9 _H	Interrupt control register 09	ICR09	R/W		00000111 _B
BA _H	Interrupt control register 10	ICR10	R/W		00000111 _B
BB _H	Interrupt control register 11	ICR11	R/W		00000111 _B
BC _H	Interrupt control register 12	ICR12	R/W		00000111 _B
BD _H	Interrupt control register 13	ICR13	R/W		00000111 _B
BE _H	Interrupt control register 14	ICR14	R/W		00000111 _B
BF _H	Interrupt control register 15	ICR15	R/W		00000111 _B
C0 _H to FF _H	External				

(Continued)

MB90440G Series

(Continued)

Address	Register	Abbreviation	Read/Write	Resource name	Initial value
1FF0H	Program address detection register 0	PADR0	R/W	Address match detection function	XXXXXXXXXB
1FF1H			R/W		XXXXXXXXXB
1FF2H			R/W		XXXXXXXXXB
1FF3H	Program address detection register 1	PADR1	R/W		XXXXXXXXXB
1FF4H			R/W		XXXXXXXXXB
1FF5H			R/W		XXXXXXXXXB

Address	Register	Abbreviation	Read/Write	Resource name	Initial value
3900H	Reload register L	PRL0	R/W	16-bit programable pulse generator 0/1	XXXXXXXXXB
3901H	Reload register H	PRLH0	R/W		XXXXXXXXXB
3902H	Reload register L	PRL1	R/W		XXXXXXXXXB
3903H	Reload register H	PRLH1	R/W		XXXXXXXXXB
3904H	Reload register L	PRL2	R/W	16-bit programable pulse generator 2/3	XXXXXXXXXB
3905H	Reload register H	PRLH2	R/W		XXXXXXXXXB
3906H	Reload register L	PRL3	R/W		XXXXXXXXXB
3907H	Reload register H	PRLH3	R/W		XXXXXXXXXB
3908H	Reload register L	PRL4	R/W	16-bit programable pulse generator 4/5	XXXXXXXXXB
3909H	Reload register H	PRLH4	R/W		XXXXXXXXXB
390AH	Reload register L	PRL5	R/W		XXXXXXXXXB
390BH	Reload register H	PRLH5	R/W		XXXXXXXXXB
390CH	Reload register L	PRL6	R/W	16-bit programable pulse generator 6/7	XXXXXXXXXB
390DH	Reload register H	PRLH6	R/W		XXXXXXXXXB
390EH	Reload register L	PRL7	R/W		XXXXXXXXXB
390FH	Reload register H	PRLH7	R/W		XXXXXXXXXB
3910H to 3917H	Reserved				
3918H	Input capture register 0	IPCP0	R	Input capture 0/1	XXXXXXXXXB
3919H	Input capture register 0	IPCP0	R		XXXXXXXXXB
391AH	Input capture register 1	IPCP1	R		XXXXXXXXXB
391BH	Input capture register 1	IPCP1	R		XXXXXXXXXB
391CH	Input capture register 2	IPCP2	R	Input capture 2/3	XXXXXXXXXB
391DH	Input capture register 2	IPCP2	R		XXXXXXXXXB
391EH	Input capture register 3	IPCP3	R		XXXXXXXXXB
391FH	Input capture register 3	IPCP3	R		XXXXXXXXXB

(Continued)

MB90440G Series

(Continued)

Address	Register	Abbreviation	Read/Write	Resource name	Initial value
3920 _H	Input capture register 4	IPCP4	R	Input capture 4/5	XXXXXXXX _B
3921 _H	Input capture register 4	IPCP4	R		XXXXXXXX _B
3922 _H	Input capture register 5	IPCP5	R		XXXXXXXX _B
3923 _H	Input capture register 5	IPCP5	R		XXXXXXXX _B
3924 _H	Input capture register 6	IPCP6	R	Input capture 6/7	XXXXXXXX _B
3925 _H	Input capture register 6	IPCP6	R		XXXXXXXX _B
3926 _H	Input capture register 7	IPCP7	R		XXXXXXXX _B
3927 _H	Input capture register 7	IPCP7	R		XXXXXXXX _B
3928 _H	Output compare register 0	OCCP0	R/W	Output compare 0/1	XXXXXXXX _B
3929 _H	Output compare register 0	OCCP0	R/W		XXXXXXXX _B
392A _H	Output compare register 1	OCCP1	R/W		XXXXXXXX _B
392B _H	Output compare register 1	OCCP1	R/W		XXXXXXXX _B
392C _H	Output compare register 2	OCCP2	R/W	Output compare 2/3	XXXXXXXX _B
392D _H	Output compare register 2	OCCP2	R/W		XXXXXXXX _B
392E _H	Output compare register 3	OCCP3	R/W		XXXXXXXX _B
392F _H	Output compare register 3	OCCP3	R/W		XXXXXXXX _B
3930 _H to 39FF _H	Reserved				
3A00 _H to 3AFF _H	Reserved for CAN 0 Interface				
3B00 _H to 3BFF _H	Reserved for CAN 0 Interface				
3C00 _H to 3CFF _H	Reserved for CAN 1 Interface				
3D00 _H to 3DFF _H	Reserved for CAN 1 Interface				
3E00 _H to 3EFF _H	Reserved for CAN 2 Interface				
3F00 _H to 3FFF _H	Reserved for CAN 2 Interface				

- Meaning of abbreviations used for reading and writing

R/W : Read and Write enabled
R : Read only
W : Write only

- Explanation of initial values

0 : The bit is initialized to 0.
1 : The bit is initialized to 1.
X : The initial value of the bit is undefined.
_ : The bit is not used. Its initial value is undefined.

Note : Addresses in the range 0000_H to 00FF_H, which are not listed in the table, are reserved for the primary functions of the MCU. A read access to these reserved addresses results reading "X" and any write access should not be performed.

■ CAN CONTROLLER

The MB90440G series contains three generic CAN controllers (CAN0, CAN1, CAN2) .

The CAN controller has the following features :

- Conforms to CAN Specification Version 2.0 Part A and B
 - Supports transmission/reception in standard frame and extended frame formats
- Supports transmission of data frames by receiving remote frames
- 16 transmission/reception message buffers
 - 29-bit ID and 8-byte data
 - Multi-level message buffer configuration
- Provides full-bit comparison, full-bit mask, acceptance register 0/acceptance register 1 for each message buffer as ID acceptance mask
 - Two acceptance mask registers in either standard frame format or extended frame formats
- Bit rate programmable from 10 Kbps to 1 Mbps (when input clock is at 16 MHz)

List of Control Registers

Address			Register	Abbreviation	Read/Write	Initial Value
CAN0	CAN1	CAN2				
000070 _H	000080 _H	00005C _H	Message buffer valid register	BVALR	R/W	00000000 00000000 _B
000071 _H	000081 _H	00005D _H				
000072 _H	000082 _H	00005E _H	Transmit request register	TREQR	R/W	00000000 00000000 _B
000073 _H	000083 _H	00005F _H				
000074 _H	000084 _H	000060 _H	Transmit cancel register	TCANR	W	00000000 00000000 _B
000075 _H	000085 _H	000061 _H				
000076 _H	000086 _H	000062 _H	Transmit complete register	TCR	R/W	00000000 00000000 _B
000077 _H	000087 _H	000063 _H				
000078 _H	000088 _H	000064 _H	Receive complete register	RCR	R/W	00000000 00000000 _B
000079 _H	000089 _H	000065 _H				
00007A _H	00008A _H	000066 _H	Remote request receiving register	RRTRR	R/W	00000000 00000000 _B
00007B _H	00008B _H	000067 _H				
00007C _H	00008C _H	000068 _H	Receive overrun register	ROVRR	R/W	00000000 00000000 _B
00007D _H	00008D _H	000069 _H				
00007E _H	00008E _H	00006A _H	Receive interrupt enable register	RIER	R/W	00000000 00000000 _B
00007F _H	00008F _H	00006B _H				
003B00 _H	003D00 _H	003F00 _H	Control status register	CSR	R/W, R	00---000 0----0- 1 _B
003B01 _H	003D01 _H	003F01 _H				
003B02 _H	003D02 _H	003F02 _H	Last event indicator register	LEIR	R/W	----- 000- 0000 _B
003B03 _H	003D03 _H	003F03 _H				
003B04 _H	003D04 _H	003F04 _H	Receive/transmit error counter	RTEC	R	00000000 00000000 _B
003B05 _H	003D05 _H	003F05 _H				

(Continued)

MB90440G Series

(Continued)

Address			Register	Abbreviation	Read/Write	Initial Value
CAN0	CAN1	CAN2				
003B06H	003D06H	003F06H	Bit timing register	BTR	R/W	-1111111 11111111 _B
003B07H	003D07H	003F07H				
003B08H	003D08H	003F08H	IDE register	IDER	R/W	XXXXXXXX XXXXXXXX _B
003B09H	003D09H	003F09H				
003B0AH	003D0AH	003F0AH	Transmit RTR register	TRTRR	R/W	00000000 00000000 _B
003B0BH	003D0BH	003F0BH				
003B0CH	003D0CH	003F0CH	Remote frame receive waiting register	RFWTR	R/W	XXXXXXXX XXXXXXXX _B
003B0DH	003D0DH	003F0DH				
003B0EH	003D0EH	003F0EH	Transmit interrupt enable register	TIER	R/W	00000000 00000000 _B
003B0FH	003D0FH	003F0FH				
003B10H	003D10H	003F10H	Acceptance mask select register	AMSR	R/W	XXXXXXXX XXXXXXXX _B
003B11H	003D11H	003F11H				
003B12H	003D12H	003F12H				XXXXXXXX XXXXXXXX _B
003B13H	003D13H	003F13H				
003B14H	003D14H	003F14H	Acceptance mask register 0	AMR0	R/W	XXXXXXXX XXXXXXXX _B
003B15H	003D15H	003F15H				
003B16H	003D16H	003F16H				XXXXX--- XXXXXXXX _B
003B17H	003D17H	003F17H				
003B18H	003D18H	003F18H	Acceptance mask register 1	AMR1	R/W	XXXXXXXX XXXXXXXX _B
003B19H	003D19H	003F19H				
003B1AH	003D1AH	003F1AH				XXXXX--- XXXXXXXX _B
003B1BH	003D1BH	003F1BH				

List of Message Buffers (ID Registers)

Address			Register	Abbreviation	Read/Write	Initial Value
CAN0	CAN1	CAN2				
003A00 _H to 003A1F _H	003C00 _H to 003C1F _H	003E00 _H to 003E1F _H	RAM area	—	R/W	XXXXXXXX _B to XXXXXXXX _B
003A20 _H	003C20 _H	003E20 _H	ID register 0	IDR0	R/W	XXXXXXXX XXXXXXXX _B
003A21 _H	003C21 _H	003E21 _H				XXXXX--- XXXXXXXX _B
003A22 _H	003C22 _H	003E22 _H				
003A23 _H	003C23 _H	003E23 _H				
003A24 _H	003C24 _H	003E24 _H	ID register 1	IDR1	R/W	XXXXXXXX XXXXXXXX _B
003A25 _H	003C25 _H	003E25 _H				XXXXX--- XXXXXXXX _B
003A26 _H	003C26 _H	003E26 _H				
003A27 _H	003C27 _H	003E27 _H				
003A28 _H	003C28 _H	003E28 _H	ID register 2	IDR2	R/W	XXXXXXXX XXXXXXXX _B
003A29 _H	003C29 _H	003E29 _H				XXXXX--- XXXXXXXX _B
003A2A _H	003C2A _H	003E2A _H				
003A2B _H	003C2B _H	003E2B _H				
003A2C _H	003C2C _H	003E2C _H	ID register 3	IDR3	R/W	XXXXXXXX XXXXXXXX _B
003A2D _H	003C2D _H	003E2D _H				XXXXX--- XXXXXXXX _B
003A2E _H	003C2E _H	003E2E _H				
003A2F _H	003C2F _H	003E2F _H				
003A30 _H	003C30 _H	003E30 _H	ID register 4	IDR4	R/W	XXXXXXXX XXXXXXXX _B
003A31 _H	003C31 _H	003E31 _H				XXXXX--- XXXXXXXX _B
003A32 _H	003C32 _H	003E32 _H				
003A33 _H	003C33 _H	003E33 _H				
003A34 _H	003C34 _H	003E34 _H	ID register 5	IDR5	R/W	XXXXXXXX XXXXXXXX _B
003A35 _H	003C35 _H	003E35 _H				XXXXX--- XXXXXXXX _B
003A36 _H	003C36 _H	003E36 _H				
003A37 _H	003C37 _H	003E37 _H				
003A38 _H	003C38 _H	003E38 _H	ID register 6	IDR6	R/W	XXXXXXXX XXXXXXXX _B
003A39 _H	003C39 _H	003E39 _H				XXXXX--- XXXXXXXX _B
003A3A _H	003C3A _H	003E3A _H				
003A3B _H	003C3B _H	003E3B _H				

(Continued)

MB90440G Series

Address			Register	Abbreviation	Read/ Write	Initial Value
CAN0	CAN1	CAN2				
003A3C _H	003C3C _H	003E3C _H	ID register 7	IDR7	R/W	XXXXXXXXX XXXXXXXXX _B
003A3D _H	003C3D _H	003E3D _H				
003A3E _H	003C3E _H	003E3E _H				
003A3F _H	003C3F _H	003E3F _H				
003A40 _H	003C40 _H	003E40 _H	ID register 8	IDR8	R/W	XXXXXXXXX XXXXXXXXX _B
003A41 _H	003C41 _H	003E41 _H				
003A42 _H	003C42 _H	003E42 _H				
003A43 _H	003C43 _H	003E43 _H				
003A44 _H	003C44 _H	003E44 _H	ID register 9	IDR9	R/W	XXXXXXXXX XXXXXXXXX _B
003A45 _H	003C45 _H	003E45 _H				
003A46 _H	003C46 _H	003E46 _H				
003A47 _H	003C47 _H	003E47 _H				
003A48 _H	003C48 _H	003E48 _H	ID register 10	IDR10	R/W	XXXXXXXXX XXXXXXXXX _B
003A49 _H	003C49 _H	003E49 _H				
003A4A _H	003C4A _H	003E4A _H				
003A4B _H	003C4B _H	003E4B _H				
003A4C _H	003C4C _H	003E4C _H	ID register 11	IDR11	R/W	XXXXXXXXX XXXXXXXXX _B
003A4D _H	003C4D _H	003E4D _H				
003A4E _H	003C4E _H	003E4E _H				
003A4F _H	003C4F _H	003E4F _H				
003A50 _H	003C50 _H	003E50 _H	ID register 12	IDR12	R/W	XXXXXXXXX XXXXXXXXX _B
003A51 _H	003C51 _H	003E51 _H				
003A52 _H	003C52 _H	003E52 _H				
003A53 _H	003C53 _H	003E53 _H				
003A54 _H	003C54 _H	003E54 _H	ID register 13	IDR13	R/W	XXXXXXXXX XXXXXXXXX _B
003A55 _H	003C55 _H	003E55 _H				
003A56 _H	003C56 _H	003E56 _H				
003A57 _H	003C57 _H	003E57 _H				
003A58 _H	003C58 _H	003E58 _H	ID register 14	IDR14	R/W	XXXXXXXXX XXXXXXXXX _B
003A59 _H	003C59 _H	003E59 _H				
003A5A _H	003C5A _H	003E5A _H				
003A5B _H	003C5B _H	003E5B _H				

(Continued)

(Continued)

Address			Register	Abbreviation	Read/Write	Initial Value
CAN0	CAN1	CAN2				
003A5C _H	003C5C _H	003E5C _H	ID register 15	IDR15	R/W	XXXXXXXXX XXXXXXXXX _B
003A5D _H	003C5D _H	003E5D _H				
003A5E _H	003C5E _H	003E5E _H				
003A5F _H	003C5F _H	003E5F _H				

List of Message Buffers (DLC Registers and Data Registers)

Address			Register	Abbreviation	Read/Write	Initial Value
CAN0	CAN1	CAN2				
003A60 _H	003C60 _H	003E60 _H	DLC register 0	DLCR0	R/W	----XXXX _B
003A61 _H	003C61 _H	003E61 _H				
003A62 _H	003C62 _H	003E62 _H	DLC register 1	DLCR1	R/W	----XXXX _B
003A63 _H	003C63 _H	003E63 _H				
003A64 _H	003C64 _H	003E64 _H	DLC register 2	DLCR2	R/W	----XXXX _B
003A65 _H	003C65 _H	003E65 _H				
003A66 _H	003C66 _H	003E66 _H	DLC register 3	DLCR3	R/W	----XXXX _B
003A67 _H	003C67 _H	003E67 _H				
003A68 _H	003C68 _H	003E68 _H	DLC register 4	DLCR4	R/W	----XXXX _B
003A69 _H	003C69 _H	003E69 _H				
003A6A _H	003C6A _H	003E6A _H	DLC register 5	DLCR5	R/W	----XXXX _B
003A6B _H	003C6B _H	003E6B _H				
003A6C _H	003C6C _H	003E6C _H	DLC register 6	DLCR6	R/W	----XXXX _B
003A6D _H	003C6D _H	003E6D _H				
003A6E _H	003C6E _H	003E6E _H	DLC register 7	DLCR7	R/W	----XXXX _B
003A6F _H	003C6F _H	003E6F _H				
003A70 _H	003C70 _H	003E70 _H	DLC register 8	DLCR8	R/W	----XXXX _B
003A71 _H	003C71 _H	003E71 _H				
003A72 _H	003C72 _H	003E72 _H	DLC register 9	DLCR9	R/W	----XXXX _B
003A73 _H	003C73 _H	003E73 _H				
003A74 _H	003C74 _H	003E74 _H	DLC register 10	DLCR10	R/W	----XXXX _B
003A75 _H	003C75 _H	003E75 _H				
003A76 _H	003C76 _H	003E76 _H	DLC register 11	DLCR11	R/W	----XXXX _B
003A77 _H	003C77 _H	003E77 _H				

(Continued)

MB90440G Series

Address			Register	Abbreviation	Read/Write	Initial Value
CAN0	CAN1	CAN2				
003A78 _H	003C78 _H	003E78 _H	DLC register 12	DLCR12	R/W	----XXXX _B
003A79 _H	003C79 _H	003E79 _H				
003A7A _H	003C7A _H	003E7A _H	DLC register 13	DLCR13	R/W	----XXXX _B
003A7B _H	003C7B _H	003E7B _H				
003A7C _H	003C7C _H	003E7C _H	DLC register 14	DLCR14	R/W	----XXXX _B
003A7D _H	003C7D _H	003E7D _H				
003A7E _H	003C7E _H	003E7E _H	DLC register 15	DLCR15	R/W	----XXXX _B
003A7F _H	003C7F _H	003E7F _H				
003A80 _H to 003A87 _H	003C80 _H to 003C87 _H	003E80 _H to 003E87 _H	Data register 0 (8 bytes)	DTR0	R/W	XXXXXXXX _B to XXXXXXXX _B
003A88 _H to 003A8F _H	003C88 _H to 003C8F _H	003E88 _H to 003E8F _H	Data register 1 (8 bytes)	DTR1	R/W	XXXXXXXX _B to XXXXXXXX _B
003A90 _H to 003A97 _H	003C90 _H to 003C97 _H	003E90 _H to 003E97 _H	Data register 2 (8 bytes)	DTR2	R/W	XXXXXXXX _B to XXXXXXXX _B
003A98 _H to 003A9F _H	003C98 _H to 003C9F _H	003E98 _H to 003E9F _H	Data register 3 (8 bytes)	DTR3	R/W	XXXXXXXX _B to XXXXXXXX _B
003AA0 _H to 003AA7 _H	003CA0 _H to 003CA7 _H	003EA0 _H to 003EA7 _H	Data register 4 (8 bytes)	DTR4	R/W	XXXXXXXX _B to XXXXXXXX _B
003AA8 _H to 003AAF _H	003CA8 _H to 003CAF _H	003EA8 _H to 003EAF _H	Data register 5 (8 bytes)	DTR5	R/W	XXXXXXXX _B to XXXXXXXX _B
003AB0 _H to 003AB7 _H	003CB0 _H to 003CB7 _H	003EB0 _H to 003EB7 _H	Data register 6 (8 bytes)	DTR6	R/W	XXXXXXXX _B to XXXXXXXX _B

(Continued)

MB90440G Series

(Continued)

Address			Register	Abbreviation	Read/ Write	Initial Value
CAN0	CAN1	CAN2				
003AB8 _H to 003ABF _H	003CB8 _H to 003CBF _H	003EB8 _H to 003EBF _H	Data register 7 (8 bytes)	DTR7	R/W	XXXXXXXX _B to XXXXXXXX _B
003AC0 _H to 003AC7 _H	003CC0 _H to 003CC7 _H	003EC0 _H to 003EC7 _H	Data register 8 (8 bytes)	DTR8	R/W	XXXXXXXX _B to XXXXXXXX _B
003AC8 _H to 003ACF _H	003CC8 _H to 003CCF _H	003EC8 _H to 003ECF _H	Data register 9 (8 bytes)	DTR9	R/W	XXXXXXXX _B to XXXXXXXX _B
003AD0 _H to 003AD7 _H	003CD0 _H to 003CD7 _H	003ED0 _H to 003ED7 _H	Data register 10 (8 bytes)	DTR10	R/W	XXXXXXXX _B to XXXXXXXX _B
003AD8 _H to 003ADF _H	003CD8 _H to 003CDF _H	003ED8 _H to 003EDF _H	Data register 11 (8 bytes)	DTR11	R/W	XXXXXXXX _B to XXXXXXXX _B
003AE0 _H to 003AE7 _H	003CE0 _H to 003CE7 _H	003EE0 _H to 003EE7 _H	Data register 12 (8 bytes)	DTR12	R/W	XXXXXXXX _B to XXXXXXXX _B
003AE8 _H to 003AEF _H	003CE8 _H to 003CEF _H	003EE8 _H to 003EEF _H	Data register 13 (8 bytes)	DTR13	R/W	XXXXXXXX _B to XXXXXXXX _B
003AF0 _H to 003AF7 _H	003CF0 _H to 003CF7 _H	003EF0 _H to 003EF7 _H	Data register 14 (8 bytes)	DTR14	R/W	XXXXXXXX _B to XXXXXXXX _B
003AF8 _H to 003AFF _H	003CF8 _H to 003CFF _H	003EF8 _H to 003EFF _H	Data register 15 (8 bytes)	DTR15	R/W	XXXXXXXX _B to XXXXXXXX _B

MB90440G Series

■ INTERRUPT FACTORS, INTERRUPT VECTORS, INTERRUPT CONTROL REGISTER

Interrupt cause	EI ² OS support	Interrupt vector		Interrupt control register	
		Number	Address	Number	Address
Reset	N/A	#08	FFFFDC _H	—	—
INT9 instruction	N/A	#09	FFFFD8 _H	—	—
Exception processing	N/A	#10	FFFFD4 _H	—	—
CAN 0 Receive	N/A	#11	FFFFD0 _H	ICR00	0000B0 _H
CAN 0 Transmit/Node status	N/A	#12	FFFFCC _H		
CAN 1 Receive	N/A	#13	FFFFC8 _H	ICR01	0000B1 _H
CAN 1 Transmit/Node status	N/A	#14	FFFFC4 _H		
External interrupt (INT0/INT1)	*1	#15	FFFFC0 _H	ICR02	0000B2 _H
Timebase timer	N/A	#16	FFFFBC _H		
16-bit reload timer 0	*1	#17	FFFFB8 _H	ICR03	0000B3 _H
8/10-bit A/D converter	*1	#18	FFFFB4 _H		
16-bit free-run timer	N/A	#19	FFFFB0 _H	ICR04	0000B4 _H
External interrupt (INT2/INT3)	*1	#20	FFFFAC _H		
Serial I/O	*1	#21	FFFFA8 _H	ICR05	0000B5 _H
8/16-bit PPG timer 0/1/2/3	N/A	#22	FFFFA4 _H		
Input capture 0	*1	#23	FFFFA0 _H	ICR06	0000B6 _H
External interrupt (INT4/INT5)	*1	#24	FFFF9C _H		
CAN 2 Receive	N/A	#25	FFFF98 _H	ICR07	0000B7 _H
CAN 2 Transmit/Node status	N/A	#26	FFFF94 _H		
External interrupt (INT6/INT7)	*1	#27	FFFF90 _H	ICR08	0000B8 _H
Monitoring timer	N/A	#28	FFFF8C _H		
Input capture 1	*1	#29	FFFF88 _H	ICR09	0000B9 _H
Input capture 2/3	*1	#30	FFFF84 _H		
8/16-bit PPG timer 4/5/6/7	N/A	#31	FFFF80 _H	ICR10	0000BA _H
Output compare 0	*1	#32	FFFF7C _H		
Output compare 1	*1	#33	FFFF78 _H	ICR11	0000BB _H
Input capture 4/5	*1	#34	FFFF74 _H		
Output compare 2/3-input capture 6/7	*1	#35	FFFF70 _H	ICR12	0000BC _H
16-bit reload timer 1	*1	#36	FFFF6C _H		
UART 0 Receive	*2	#37	FFFF68 _H	ICR13	0000BD _H
UART 0 Transmit	*1	#38	FFFF64 _H		
UART 1 Receive	*2	#39	FFFF60 _H	ICR14	0000BE _H
UART 1 Transmit	*1	#40	FFFF5C _H		

(Continued)

(Continued)

Interrupt cause	EI ² OS support	Interrupt vector		Interrupt control register	
		Number	Address	Number	Address
Flash memory	N/A	#41	FFFF58 _H	ICR15	0000BF _H
Delayed interrupt generation module	N/A	#42	FFFF54 _H		

*1 : The interrupt request flag is cleared by the EI²OS interrupt clear signal.

*2 : The interrupt request flag is cleared by the EI²OS interrupt clear signal. A stop request is available.

Notes : • N/A : The interrupt request flag is not cleared by the EI²OS interrupt clear signal.

- For a peripheral module with two interrupt causes for a single interrupt number, both interrupt request flags are cleared by the EI²OS interrupt clear signal.
- At the end of EI²OS, the EI²OS clear signal will be asserted for all the interrupt flags assigned to the same interrupt number. If one interrupt flag starts the EI²OS and in the meantime another interrupt flag is set by hardware event, the later event is lost because the flag is cleared by the EI²OS clear signal caused by the first event. So it is recommended not to use the EI²OS for this interrupt number.
- If EI²OS is enabled, EI²OS is initiated when one of the two interrupt signals in the same interrupt control register (ICR) is asserted. This means that different interrupt causes share the same EI²OS descriptor which should be unique for each interrupt cause. For this reason, when one interrupt cause uses the EI²OS, the other interrupt should be disabled.

MB90440G Series

■ ELECTRICAL CHARACTERISTICS

1. Absolute Maximum Ratings

($V_{SS} = AV_{SS} = 0.0\text{ V}$)

Parameter	Symbol	Rating		Unit	Remarks
		Min	Max		
Power supply voltage	V_{CC}	$V_{SS} - 0.3$	$V_{SS} + 6.0$	V	
	AV_{CC}	$V_{SS} - 0.3$	$V_{SS} + 6.0$	V	$V_{CC} = AV_{CC}^{*1}$
	AVRH, AVRL	$V_{SS} - 0.3$	$V_{SS} + 6.0$	V	$AV_{CC} \geq AVRH / AVRL$, $AVRH \geq AVRL^{*1}$
Input voltage	V_I	$V_{SS} - 0.3$	$V_{SS} + 6.0$	V	^{*2}
Output voltage	V_O	$V_{SS} - 0.3$	$V_{SS} + 6.0$	V	^{*2}
Maximum clamp current	I_{CLAMP}	- 2.0	+ 2.0	mA	^{*6}
Total maximum clamp current	$\Sigma I_{CLAMP} $	—	20	mA	^{*6}
“L” level maximum output current	I_{OL}	—	15	mA	^{*3}
“L” level average output current	I_{OLAV}	—	4	mA	^{*4}
“L” level total maximum output current	ΣI_{OL}	—	100	mA	
“L” level total average output current	ΣI_{OLAV}	—	50	mA	^{*5}
“H” level maximum output current	I_{OH}	—	-15	mA	^{*3}
“H” level average output current	I_{OHAV}	—	-4	mA	^{*4}
“H” level total maximum output current	ΣI_{OH}	—	-100	mA	
“H” level total average output current	ΣI_{OHAV}	—	-50	mA	^{*5}
Power consumption	P_D	—	500	mW	MB90F443G
		—	400	mW	MB90F443G (under development)
Operating temperature	T_A	-40	+ 105	°C	
Storage temperature	T_{stg}	-55	+ 150	°C	

^{*1} : AV_{CC} , AVRH, and AVRL shall never exceed V_{CC} . AVRH, AVRL shall never exceed AV_{CC} . Also, AVRL shall never exceed AVRH.

^{*2} : V_I and V_O shall never exceed $V_{CC} + 0.3\text{ V}$. V_I shall never exceed the specified ratings. However if the maximum current to/ from an input is limited by some means with external components, the I_{CLAMP} rating supersedes the V_I rating.

^{*3} : Maximum output current specifies the peak value of the corresponding pin.

^{*4} : The average output current specifies the average current of corresponding pins within 100 ms.
(operation current \times operation rate = average value)

^{*5} : The total average output current specifies the average current of all corresponding pins within 100 ms.
(operation current \times operation rate = average value)

^{*6} : • Applicable to pins : P00 to P07, P10 to P17, P20 to P27, P30 to P37, P40 to P47, P50 to P57, P60 to P67, P70 to P77, P80 to P87, P90 to P97, PA0

- Use within recommended operating conditions.
- Use at DC voltage (current) .

(Continued)

(Continued)

- The +B signal should always be applied with a limiting resistance placed between the +B signal and the microcontroller.
- The value of the limiting resistance should be set so that +B signal is applied the input current to the microcontroller pin does not exceed rated values, either instantaneously or for prolonged periods.
- Note that when the microcontroller drive current is low, such as in the power saving modes, the +B input potential may pass through the protective diode and increase the potential at the V_{CC} pin, and this may affect other devices.
- Note that if a +B signal is input when the microcontroller power supply is off (not fixed at 0 V) , the power supply is provided from the pins, so that incomplete operation may result.
- Note that if the +B input is applied during power-on, the power supply is provided from the pins and the resulting supply voltage may not be sufficient to operate the power-on reset.
- Care must be taken not to leave the +B input pin open.
- Note that analog system input/output pins other than the A/D input pins (LCD drive pins, comparator input pins, etc.) cannot accept +B signal input.
- Sample recommended circuits.

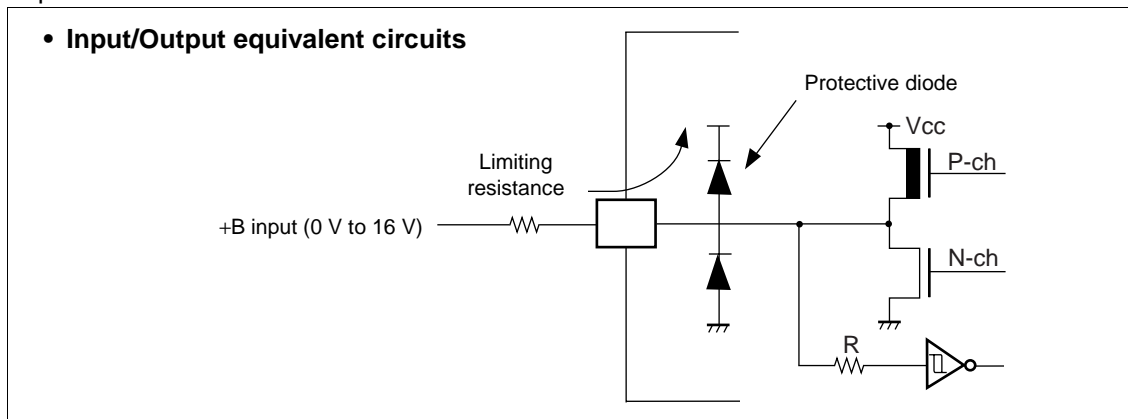

WARNING: Semiconductor devices can be permanently damaged by application of stress (voltage, current, temperature, etc.) in excess of absolute maximum ratings. Do not exceed these ratings.

MB90440G Series

2. Recommended Operating Conditions

($V_{SS} = AV_{SS} = 0.0\text{ V}$)

Parameter	Symbol	Value			Unit	Remarks
		Min	Typ	Max		
Power supply voltage	V_{CC}, AV_{CC}	4.5	5.0	5.5	V	Under normal operation
		3.0	—	5.5	V	Retains status at the time of operation stop
Smoothing capacitor	C_S	0.022	0.1	1.0	μF	*
Operating temperature	T_A	-40	—	+105	$^{\circ}\text{C}$	

* : Use a ceramic capacitor or capacitor of better AC characteristics. Capacitor at the V_{CC} should be greater than this capacitor.

WARNING: The recommended operating conditions are required in order to ensure the normal operation of the semiconductor device. All of the device's electrical characteristics are warranted when the device is operated within these ranges.

Always use semiconductor devices within their recommended operating condition ranges. Operation outside these ranges may adversely affect reliability and could result in device failure.

No warranty is made with respect to uses, operating conditions, or combinations not represented on the data sheet. Users considering application outside the listed conditions are advised to contact their representatives beforehand.

• C pin connection circuit

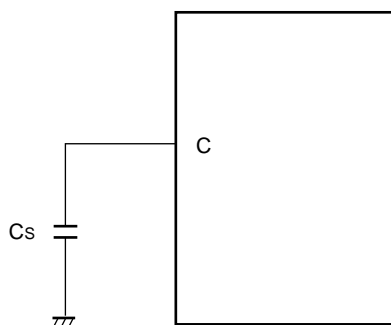

3. DC Characteristics

($V_{CC} = 5.0 \text{ V} \pm 10\%$, $V_{SS} = AV_{SS} = 0.0 \text{ V}$, $T_A = -40 \text{ }^\circ\text{C}$ to $+105 \text{ }^\circ\text{C}$)

Parameter	Symbol	Pin	Condition	Value			Unit	Remarks
				Min	Typ	Max		
Input H voltage	V_{IHS}	CMOS Hysteresis input pin	—	$0.8 V_{CC}$	—	$V_{CC} + 0.3$	V	
	V_{IHA}	AUTOMOTIVE input pin	—	$0.8 V_{CC}$	—	—	V	
	V_{IH}	TTL input pin	—	2.0	—	—	V	
	V_{IHM}	MD input pin	—	$V_{CC} - 0.3$	—	$V_{CC} + 0.3$	V	
Input L voltage	V_{ILS}	CMOS Hysteresis input pin	—	$V_{SS} - 0.3$	—	$0.2 V_{CC}$	V	
	V_{ILA}	AUTOMOTIVE input pin	—	—	—	$0.5 V_{CC}$	V	
	V_{IL}	TTL input pin	—	—	—	0.8	V	
	V_{ILM}	MD input pin	—	$V_{SS} - 0.3$	—	$V_{SS} + 0.3$	V	
Output H voltage	V_{OH}	All output pins	$V_{CC} = 4.5 \text{ V}$, $I_{OH} = -4.0 \text{ mA}$	$V_{CC} - 0.5$	—	—	V	
Output L voltage	V_{OL}	All output pins	$V_{CC} = 4.5 \text{ V}$, $I_{OL} = 4.0 \text{ mA}$	—	—	0.4	V	
Input leak current	I_{IL}	—	$V_{CC} = 5.5 \text{ V}$, $V_{SS} < V_I < V_{CC}$	-5	—	+5	μA	

(Continued)

MB90440G Series

(Continued)

($V_{CC} = 5.0\text{ V} \pm 10\%$, $V_{SS} = AV_{SS} = 0.0\text{ V}$, $T_A = -40\text{ }^\circ\text{C}$ to $+105\text{ }^\circ\text{C}$)

Parameter	Symbol	Pin	Condition	Value			Unit	Remarks
				Min	Typ	Max		
Power supply current*	I _{CC}	V _{CC}	V _{CC} = 5.0 V Internal frequency : 16 MHz, At normal operating	—	45	60	mA	
			V _{CC} = 5.0 V Internal frequency : 16 MHz, At flash programming / erasing	—	50	70	mA	
	I _{CCS}		V _{CC} = 5.0 V Internal frequency : 16 MHz, At sleep	—	13	22	mA	
	I _{CCL}		V _{CC} = 5.0 V Internal frequency : 8 kHz, At sub operation T _A = +25 °C	—	50	100	μA	MB90443G (under devel- opment)
			—	300	500	μA	MB90F443G	
	I _{CCLS}		V _{CC} = 5.0 V Internal frequency : 8 kHz, At sub sleep T _A = +25 °C	—	15	40	μA	
	I _{CC T}		V _{CC} = 5.0 V Internal frequency : 8 kHz, At watch mode T _A = +25 °C	—	7	25	μA	
	I _{CTS}		V _{CC} = 5.0 V Internal frequency : 2 MHz, At timer base timer mode T _A = +25 °C	—	600	1200	μA	
I _{CC H}	At stop mode, T _A = +25 °C	—	5	20	μA			
Input capacity	C _{IN}	Other than AV _{CC} , AV _{SS} , AVRH, AVRL, C, V _{CC} , V _{SS}	—	10	15	pF		
Pull-up resistance	R _{UP}	P00 to P07, P10 to P17, P20 to P27, P30 to P37, $\overline{\text{RST}}$	—	25	50	100	kΩ	
Pull-down resistance	R _{DOWN}	MD2	—	25	50	100	kΩ	

* : The power supply current is measured with an external clock.

4. AC Characteristics

(1) Clock Timing

($V_{CC} = 5.0\text{ V} \pm 10\%$, $V_{SS} = AV_{SS} = 0.0\text{ V}$, $T_A = -40\text{ }^\circ\text{C}$ to $+105\text{ }^\circ\text{C}$)

Parameter	Symbol	Pin	Value			Unit	Remarks
			Min	Typ	Max		
Clock frequency	f_c	X0, X1	3	—	16	MHz	Not multiplied
			8	—	16	MHz	PLL multiplied by 1*
			4	—	8	MHz	PLL multiplied by 2*
			3	—	5.33	MHz	PLL multiplied by 3*
			3	—	4	MHz	PLL multiplied by 4*
	f_{CL}	X0A, X1A	—	32.768	—	kHz	
Clock cycle time	t_{CYL}	X0, X1	62.5	—	333	ns	
	t_{LCYL}	X0A, X1A	—	30.5	—	μs	
Input clock pulse width	P_{WH}, P_{WL}	X0	10	—	—	ns	Duty ratio is about 30% to 70%.
	P_{WLH}, P_{WLL}	X0A	—	15.2	—	μs	
Input clock rise and fall time	t_{CR}, t_{CF}	X0	—	—	5	ns	When using external clock
Internal operating clock frequency	f_{CP}	—	1.5	—	16	MHz	When using main clock
	f_{LCP}	—	—	8.192	—	kHz	When using sub-clock
Internal operating clock cycle time	t_{CP}	—	62.5	—	666	ns	When using main clock
	t_{LCP}	—	—	122.1	—	μs	When using sub-clock

* : When selecting the PLL clock, the range of clock frequency is limited. Use this product within range as mentioned in "• Guaranteed PLL operation range : Relationship between oscillation frequency and internal operating clock frequency".

• Clock Timing

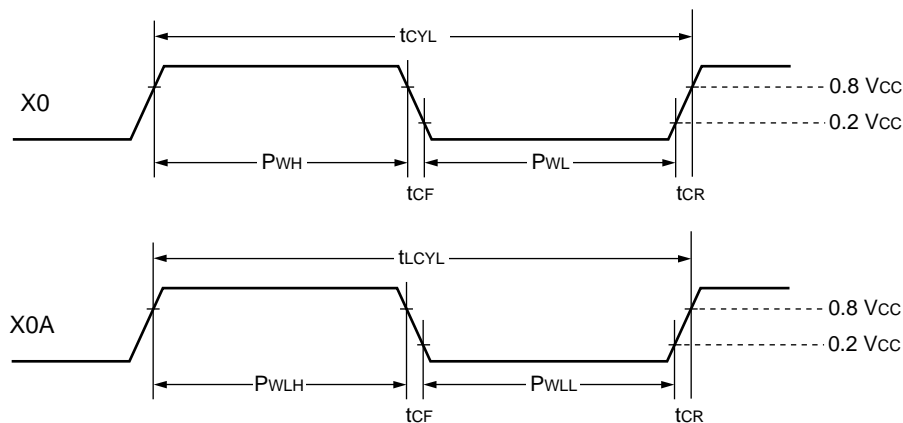

MB90440G Series

- **Guaranteed PLL operation range**

Relationship between internal operation clock frequency and power supply voltage

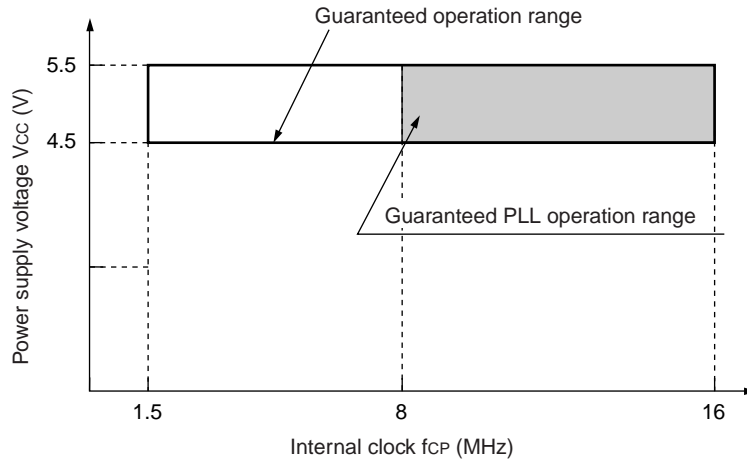

Relationship between oscillation frequency and internal operating clock frequency

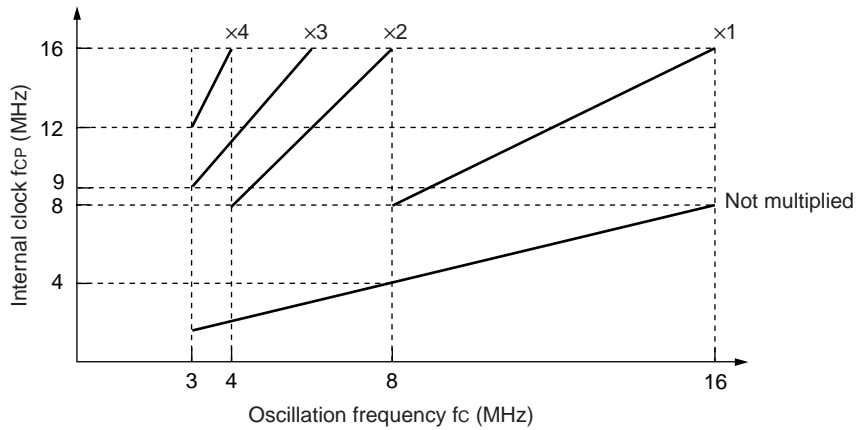

The AC ratings are measured for the following measurement reference voltages.

- **Input signal waveform**

CMOS Hysteresis Input Pin

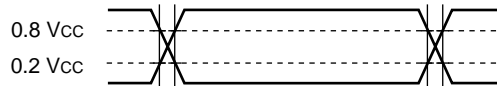

TTL Input Pin



AUTOMOTIVE Input Pin



- **Output signal waveform**

Output Pin



(2) Clock Output Timing

($V_{CC} = 5.0\text{ V} \pm 10\%$, $V_{SS} = AV_{SS} = 0.0\text{ V}$, $T_A = -40\text{ }^\circ\text{C}$ to $+105\text{ }^\circ\text{C}$)

Parameter	Symbol	Pin	Condition	Value		Unit	Remarks
				Min	Max		
Cycle time	t_{CYC}	CLK	$V_{CC} = 5\text{ V} \pm 10\%$	62.5	—	ns	
CLK $\uparrow \rightarrow$ CLK \downarrow	t_{CHCL}			20	—	ns	

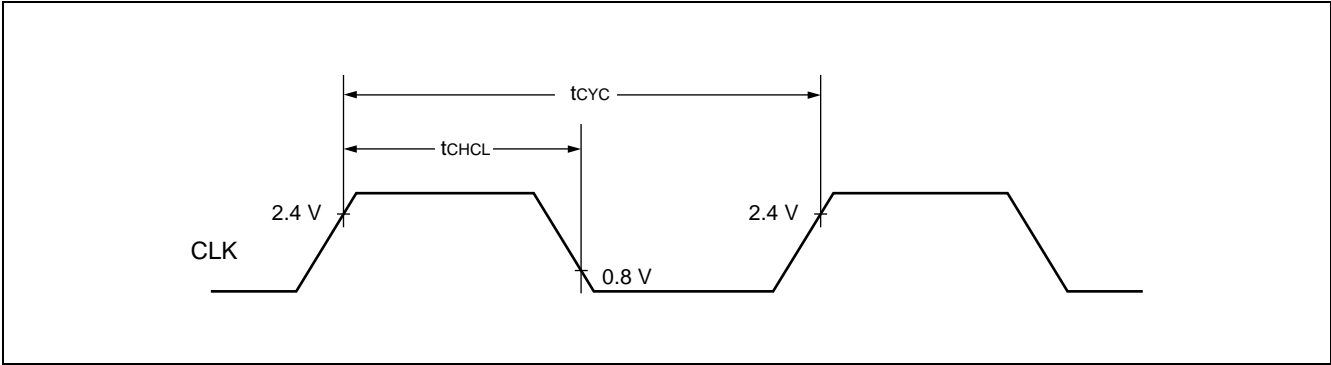

MB90440G Series

(3) Reset Input Timing and Hardware Stand-by Input Timing

($V_{CC} = 5.0\text{ V} \pm 10\%$, $V_{SS} = AV_{SS} = 0.0\text{ V}$, $T_A = -40\text{ }^{\circ}\text{C}$ to $+105\text{ }^{\circ}\text{C}$)

Parameter	Symbol	Pin	Value		Unit	Remarks
			Min	Max		
Reset input time	t_{RSTL}	\overline{RST}	16 t_{CP}	—	ns	Under normal operation
			Oscillation time of oscillator + $100\text{ }\mu\text{s} + 16\text{ }t_{CP}$	—	—	In stop mode, watch mode, sub-clock mode, sub-sleep mode

- Note:
- Oscillator oscillation time is the time that amplitude reached 90%. For a crystal oscillator, the oscillation time is between several ms to tens of ms; for a ceramic oscillator, the oscillation time is between hundreds of μs to several ms, and for an external clock the oscillation time is 0 ms.
 - Any reset can not fully initialize the Flash Memory if it is performing the automatic algorithm.

• Under normal operation :



• In stop mode :

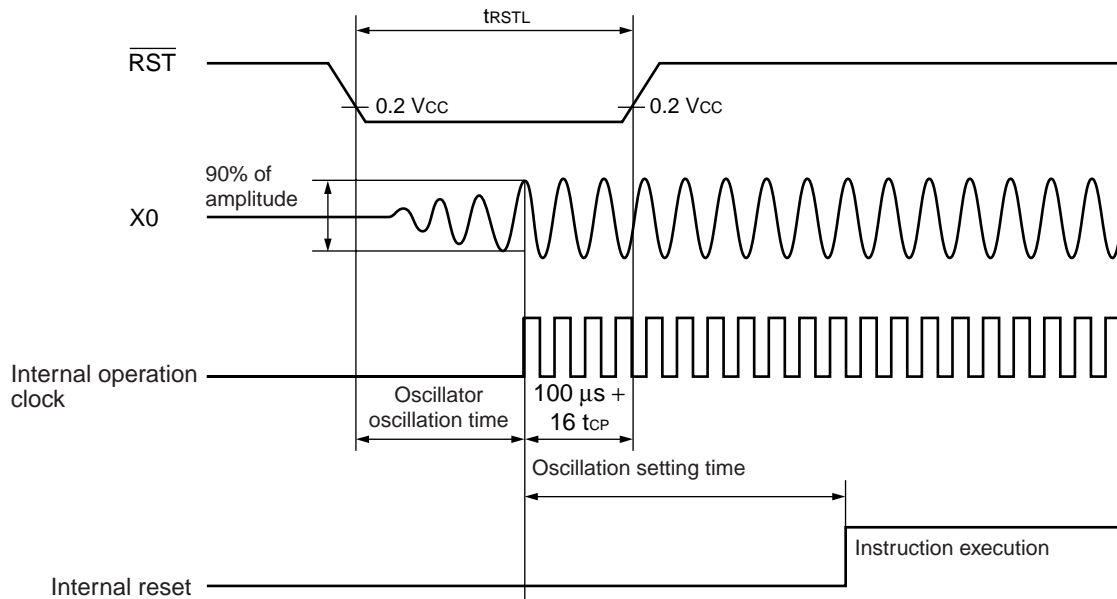

(4) Power-on Reset

($V_{CC} = 5.0\text{ V} \pm 10\%$, $V_{SS} = AV_{SS} = 0.0\text{ V}$, $T_A = -40\text{ }^\circ\text{C}$ to $+105\text{ }^\circ\text{C}$)

Parameter	Symbol	Pin	Condition	Value		Unit	Remarks
				Min	Max		
Power supply rising time	t_R	V_{CC}	—	0.05	30	ms	*
Power supply cut-off time	t_{OFF}	V_{CC}		50	—	ms	Due to repeated operations

* : V_{CC} must be kept lower than 0.2 V before power-on.

Note : The above values are used for causing a power-on reset.

Some registers in the device are initialized only upon a power-on reset. To initialize these registers, turn the power supply on using the above values.

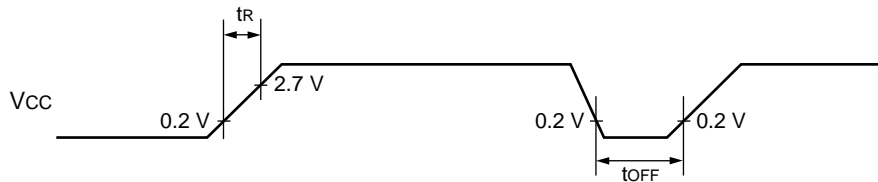

Sudden changes in the power supply voltage may cause a power on reset. We recommend to raise the voltage smoothly to suppress fluctuation during operation, as shown in the figure below. Perform while not using the PLL clock. However, if voltage drops are within 1 V/s, you can operate while using the PLL clock.



MB90440G Series

(5) Bus Timing (Read)

($V_{CC} = 4.5 \text{ V to } 5.5 \text{ V}$, $V_{SS} = 0.0 \text{ V}$, $T_A = -40 \text{ }^\circ\text{C to } +105 \text{ }^\circ\text{C}$)

Parameter	Symbol	Pin	Value		Unit	Remarks
			Min	Max		
ALE pulse width	t_{LHLL}	ALE	$t_{CP} / 2 - 20$	—	ns	
Valid address → ALE ↓ time	t_{AVLL}	ALE, A16 to A23, AD00 to AD15	$t_{CP} / 2 - 20$	—	ns	
ALE ↓ → Address valid time	t_{LLAX}	ALE, AD00 to AD15	$t_{CP} / 2 - 15$	—	ns	
Valid address → \overline{RD} ↓ time	t_{AVRL}	A16 to A23, AD00 to AD15, \overline{RD}	$t_{CP} - 15$	—	ns	
Valid address → Valid data input	t_{AVDV}	A16 to A23, AD00 to AD15	—	$5 t_{CP} / 2 - 60$	ns	
\overline{RD} pulse width	t_{RLRH}	\overline{RD}	$3 t_{CP} / 2 - 20$	—	ns	
\overline{RD} ↓ → Valid data input	t_{RLDV}	\overline{RD} , AD00 to AD15	—	$3 t_{CP} / 2 - 60$	ns	
\overline{RD} ↑ → Data hold time	t_{RHDX}	\overline{RD} , AD00 to AD15	0	—	ns	
\overline{RD} ↑ → ALE ↑ time	t_{RHLH}	\overline{RD} , ALE	$t_{CP} / 2 - 15$	—	ns	
\overline{RD} ↑ → Address valid time	t_{RHAX}	\overline{RD} , A16 to A23	$t_{CP} / 2 - 10$	—	ns	
Valid address → CLK ↑ time	t_{AVCH}	A16 to A23, AD00 to AD15, CLK	$t_{CP} / 2 - 20$	—	ns	
\overline{RD} ↓ → CLK ↑ time	t_{RLCH}	\overline{RD} , CLK	$t_{CP} / 2 - 20$	—	ns	
ALE ↓ → \overline{RD} ↓ time	t_{LLRL}	ALE, \overline{RD}	$t_{CP} / 2 - 15$	—	ns	

• Bus Timing (Read)

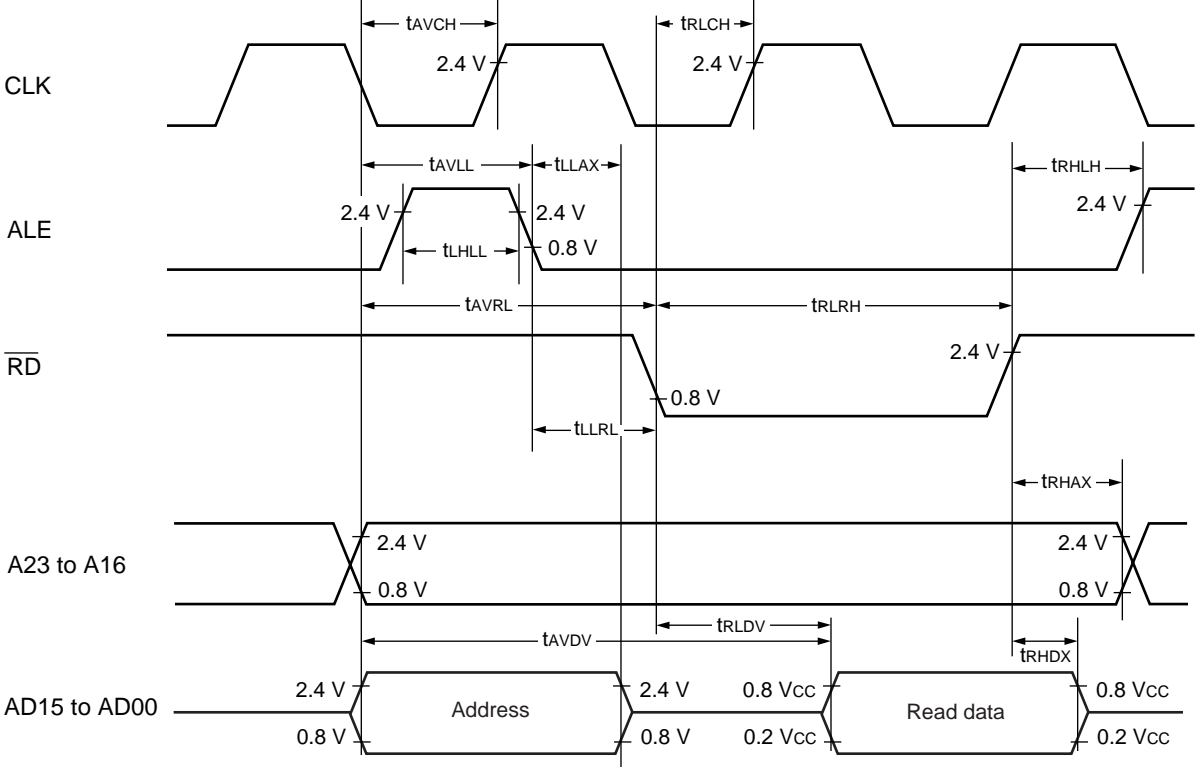

MB90440G Series

(6) Bus Timing (Write)

($V_{CC} = 4.5\text{ V to }5.5\text{ V}$, $V_{SS} = 0.0\text{ V}$, $T_A = -40\text{ }^\circ\text{C to }+105\text{ }^\circ\text{C}$)

Parameter	Symbol	Pin	Value		Unit	Remarks
			Min	Max		
Valid address $\rightarrow \overline{\text{WR}} \downarrow$ time	t_{AVWL}	A16 to A23, AD00 to AD15, $\overline{\text{WR}}$	$t_{CP} - 15$	—	ns	
$\overline{\text{WR}}$ pulse width	t_{WLWH}	$\overline{\text{WR}}$	$3 t_{CP} / 2 - 20$	—	ns	
Valid data output $\rightarrow \overline{\text{WR}} \uparrow$ time	t_{DVWH}	AD00 to AD15, $\overline{\text{WR}}$	$3 t_{CP} / 2 - 20$	—	ns	
$\overline{\text{WR}} \uparrow \rightarrow$ Data hold time	t_{WHDX}	AD00 to AD15, $\overline{\text{WR}}$	20	—	ns	
$\overline{\text{WR}} \uparrow \rightarrow$ Address valid time	t_{WHAX}	A16 to A23, $\overline{\text{WR}}$	$t_{CP} / 2 - 10$	—	ns	
$\overline{\text{WR}} \uparrow \rightarrow$ ALE \uparrow time	t_{WHLH}	$\overline{\text{WR}}$, ALE	$t_{CP} / 2 - 15$	—	ns	
$\overline{\text{WR}} \downarrow \rightarrow$ CLK \uparrow time	t_{WLCH}	$\overline{\text{WR}}$, CLK	$t_{CP} / 2 - 20$	—	ns	

• Bus Timing (Write)

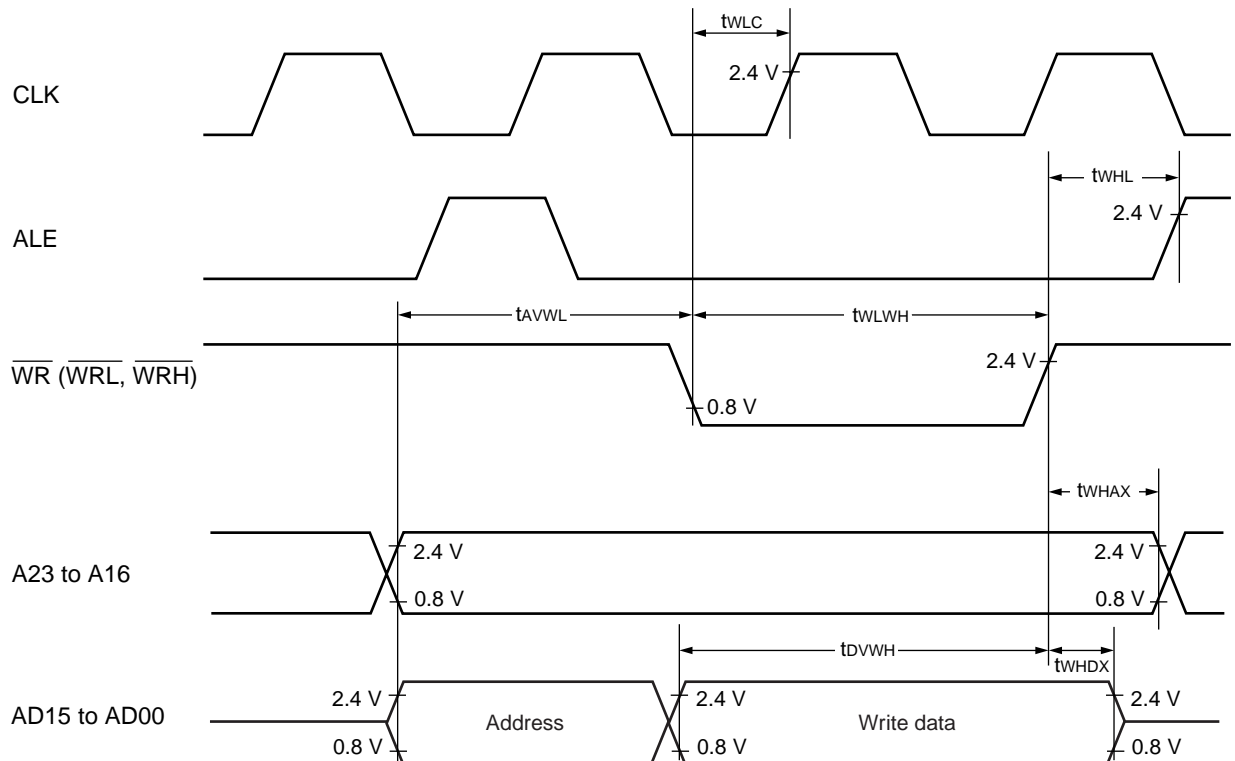

(7) Ready Input Timing

($V_{CC} = 4.5\text{ V to }5.5\text{ V}$, $V_{SS} = 0.0\text{ V}$, $T_A = -40\text{ }^\circ\text{C to }+105\text{ }^\circ\text{C}$)

Parameter	Symbol	Pin	Value		Unit	Remarks
			Min	Max		
RDY setup time	t_{RYHS}	RDY	45	—	ns	
RDY hold time	t_{RYHH}	RDY	0	—	ns	

Note : If the RDY setup time is insufficient, use the auto-ready function.

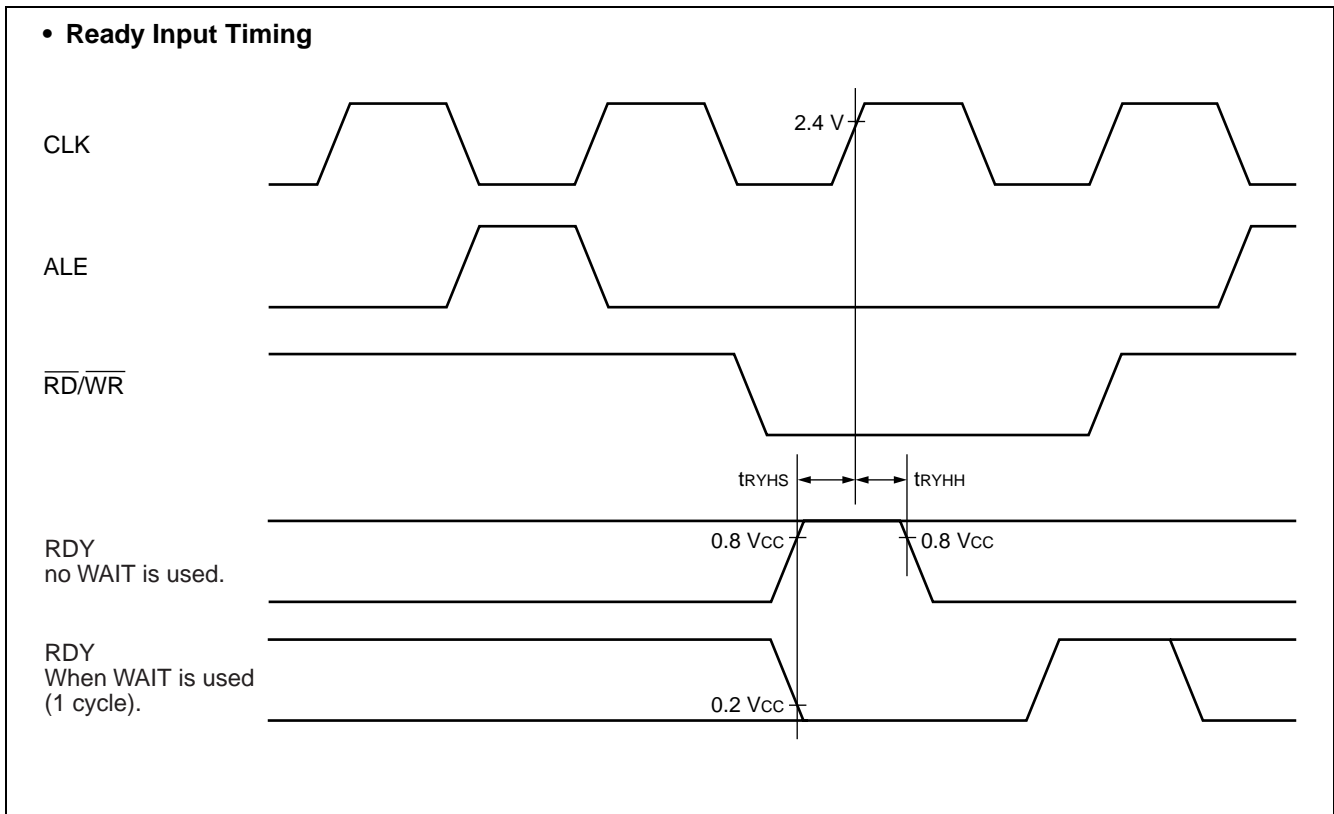

MB90440G Series

(8) Hold Timing

($V_{CC} = 4.5 \text{ V to } 5.5 \text{ V}$, $V_{SS} = 0.0 \text{ V}$, $T_A = -40 \text{ }^\circ\text{C to } +105 \text{ }^\circ\text{C}$)

Parameter	Symbol	Pin	Value		Unit	Remarks
			Min	Max		
Pin floating $\rightarrow \overline{\text{HAK}} \downarrow$ time	t_{XHAL}	$\overline{\text{HAK}}$	30	t_{CP}	ns	
$\overline{\text{HAK}} \uparrow \rightarrow$ Pin valid time	t_{HAHV}	$\overline{\text{HAK}}$	t_{CP}	$2 t_{CP}$	ns	

Note : More than 1 machine cycle is needed before $\overline{\text{HAK}}$ changes after HRQ pin is fetched.

• Hold Timing

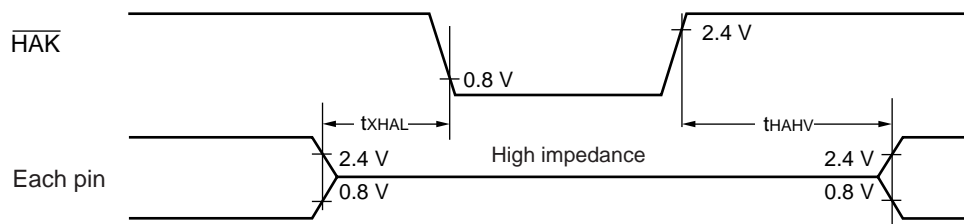

(9) UART0/1, Serial I/O Timing

($V_{CC} = 4.5\text{ V to }5.5\text{ V}$, $V_{SS} = 0.0\text{ V}$, $T_A = -40\text{ }^{\circ}\text{C to }+105\text{ }^{\circ}\text{C}$)

Parameter	Symbol	Pin	Condition	Value		Unit	Remarks
				Min	Max		
Serial clock cycle time	t_{SCYC}	SCK0 to SCK2	An output pin of internal sift clock mode $C_L = 80\text{ pF} + 1\text{ TTL}$.	4 t_{CP}	—	ns	
SCK ↓ → SOT delay time	t_{SLOV}	SCK0 to SCK2, SOT0 to SOT2		-80	+80	ns	
Valid SIN → SCK ↑	t_{VSH}	SCK0 to SCK2, SIN0 to SIN2		100	—	ns	
SCK ↑ → valid SIN hold time	t_{SHIX}	SCK0 to SCK2, SIN0 to SIN2		60	—	ns	
Serial clock "H" pulse width	t_{SHSL}	SCK0 to SCK2	An output pin of external sift clock mode $C_L = 80\text{ pF} + 1\text{ TTL}$.	4 t_{CP}	—	ns	
Serial clock "L" pulse width	t_{SLSH}	SCK0 to SCK2		4 t_{CP}	—	ns	
SCK ↓ → SOT delay time	t_{SLOV}	SCK0 to SCK2, SOT0 to SOT2		—	150	ns	
Valid SIN → SCK ↑	t_{VSH}	SCK0 to SCK2, SIN0 to SIN2		60	—	ns	
SCK ↑ → valid SIN hold time	t_{SHIX}	SCK0 to SCK2, SIN0 to SIN2		60	—	ns	

Notes : • AC ratings in CLK synchronous mode.

- C_L is load capacitance value connected to pins when testing.

MB90440G Series

• Internal Shift Clock Mode

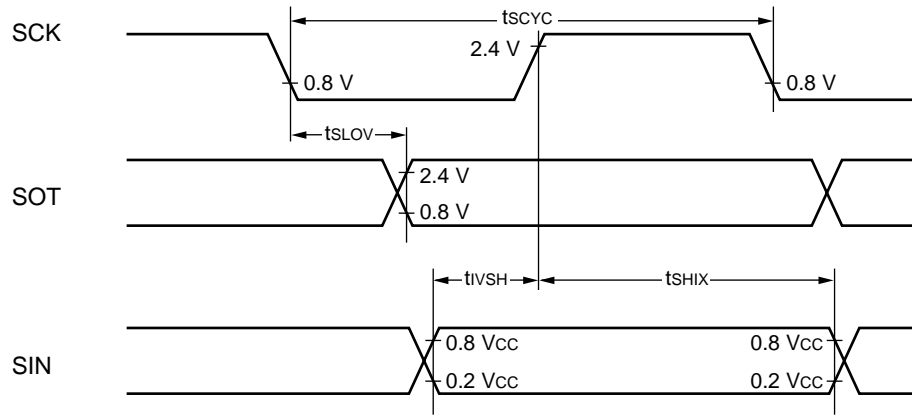

• External Shift Clock Mode

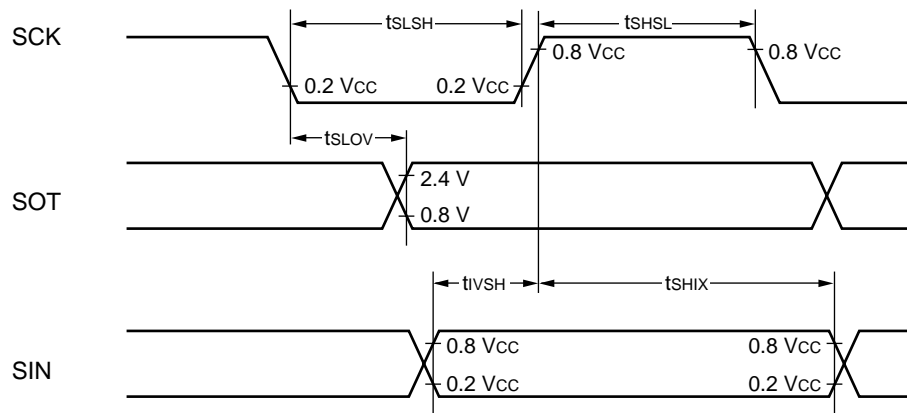

(10) Timer Related Resource Input Timing

($V_{CC} = 4.5\text{ V to }5.5\text{ V}$, $V_{SS} = 0.0\text{ V}$, $T_A = -40\text{ }^\circ\text{C to }+105\text{ }^\circ\text{C}$)

Parameter	Symbol	Pin	Condition	Value		Unit	Remarks
				Min	Max		
Input pulse width	t_{IWH}	TIN0, TIN1	—	4 t_{CP}	—	ns	
	t_{IWL}	IN0 to IN7					

• Timer Input Timing

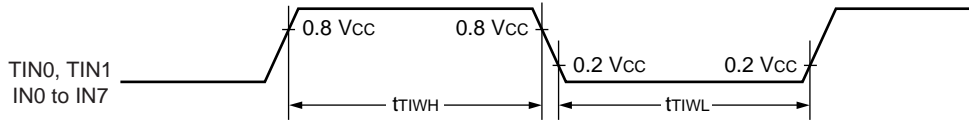

MB90440G Series

(11) Timer Related Resource Output Timing

($V_{CC} = 4.5\text{ V to }5.5\text{ V}$, $V_{SS} = 0.0\text{ V}$, $T_A = -40\text{ }^\circ\text{C to }+105\text{ }^\circ\text{C}$)

Parameter	Symbol	Pin	Condition	Value		Unit	Remarks
				Min	Max		
CLK \uparrow \rightarrow T_{OUT} transition time	t_{ro}	TOT0 to TOT1, PPG0 to PPG3	—	30	—	ns	

• Timer Output Timing

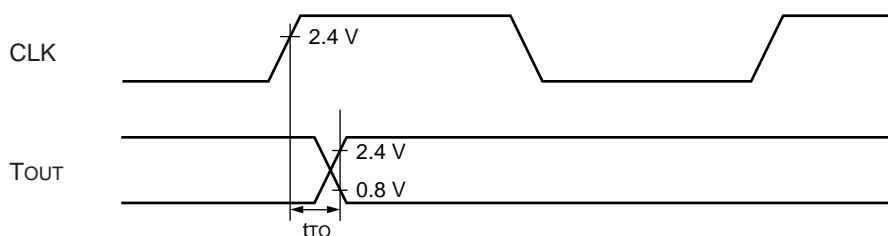

(12) Trigger Input Timing

($V_{CC} = 4.5\text{ V to }5.5\text{ V}$, $V_{SS} = 0.0\text{ V}$, $T_A = -40\text{ }^\circ\text{C to }+105\text{ }^\circ\text{C}$)

Parameter	Symbol	Pin	Condition	Value		Unit	Remarks
				Min	Max		
Input pulse width	t_{TRGH}	INT0 to INT7, ADTG	—	$5 t_{CP}$	—	ns	normal operation
	t_{TRGL}			1	—	μs	stop mode

• Trigger Input Timing

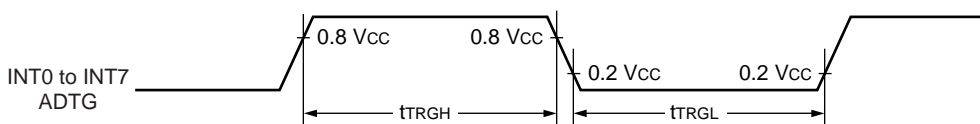

5. A/D Converter

- Electrical Characteristics

($V_{CC} = AV_{CC} = 5.0 \text{ V} \pm 10\%$, $V_{SS} = AV_{SS} = 0.0 \text{ V}$, $3.0 \text{ V} \leq AVRH - AVRL$, $T_A = -40 \text{ }^\circ\text{C}$ to $+105 \text{ }^\circ\text{C}$)

Parameter	Symbol	Pin	Value			Unit	Remarks
			Min	Typ	Max		
Resolution	—	—	—	—	10	bit	
Total error	—	—	—	—	± 5.0	LSB	
Nonlinearity error	—	—	—	—	± 2.5	LSB	
Differential linearity error	—	—	—	—	± 1.9	LSB	
Zero transition voltage	V_{OT}	AN0 to AN7	$AVRL - 3.5 \text{ LSB}$	$AVRL + 0.5 \text{ LSB}$	$AVRL + 4.5 \text{ LSB}$	V	1 LSB = $(AVRH - AVRL) / 1024$ [V]
Full scale transition voltage	V_{FST}	AN0 to AN7	$AVRH - 6.5 \text{ LSB}$	$AVRH - 1.5 \text{ LSB}$	$AVRH + 1.5 \text{ LSB}$	V	
Compare time	—	—	66 t_{CP}	—	—	ns	Machine clock of 16 MHz
Sampling time	—	—	32 t_{CP}	—	—	ns	
Analog port input current	I_{AIN}	AN0 to AN7	—	—	10	μA	
Analog input voltage	V_{AIN}	AN0 to AN7	AVRL	—	AVRH	V	
Reference voltage	—	AVRH	$AVRL + 2.7 \text{ LSB}$	—	AV_{CC}	V	
	—	AVRL	0	—	$AVRH - 2.7 \text{ LSB}$	V	
Power supply current	I_A	AV_{CC}	—	2	6	mA	
	I_{AH}	AV_{CC}	—	—	5	μA	*
Reference voltage supply current	I_R	AVRH	—	0.9	1.3	mA	
	I_{RH}	AVRH	—	—	5	μA	*
Offset between channels	—	AN0 to AN7	—	—	4	LSB	

* : Specifies the power supply current ($V_{CC} = AV_{CC} = AVRH = 5.0 \text{ V}$) when the A/D converter is inactive and the CPU has been stopped.

• A/D Converter Glossary

- Resolution : Analog changes that are identifiable with the A/D converter
- Linearity error : The deviation of the straight line connecting the zero transition point (“00 0000 0000” to “00 0000 0001”) with the full-scale transition point (“11 1111 1110” to “11 1111 1111”) from actual conversion characteristics.
- Differential linearity error : The deviation of input voltage needed to change the output code by 1 LSB from the theoretical value.
- Total error : The difference between the actual value and the theoretical value, which includes zero-transition error/full-scale transition error, and linearity error.

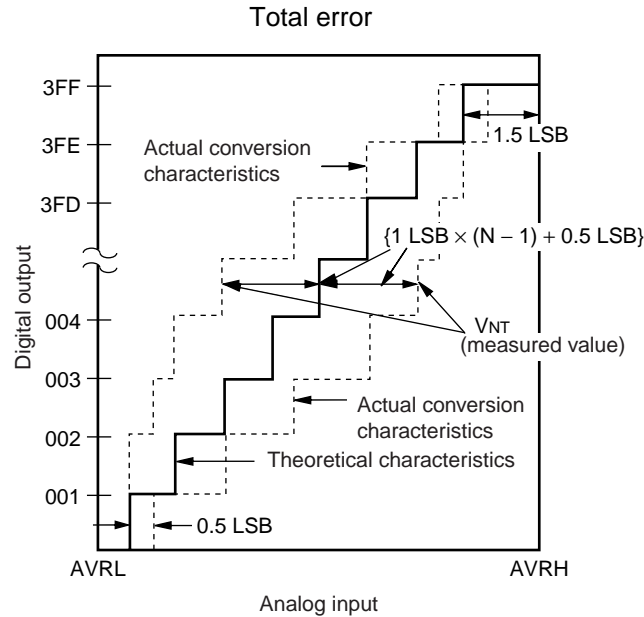

$$\text{Total error of digital output } N = \frac{V_{NT} - \{1 \text{ LSB} \times (N - 1) + 0.5 \text{ LSB}\}}{1 \text{ LSB}} \text{ [LSB]}$$

$$1 \text{ LSB} = (\text{theoretical value}) \frac{AVRH - AVRL}{1024} \text{ [V]}$$

$$V_{OT} (\text{theoretical value}) = AVRL + 0.5 \text{ LSB [V]}$$

$$V_{FST} (\text{theoretical value}) = AVRH - 1.5 \text{ LSB [V]}$$

V_{NT} : The voltage at a transition of digital output from $(N - 1)$ to N .

(Continued)

(Continued)

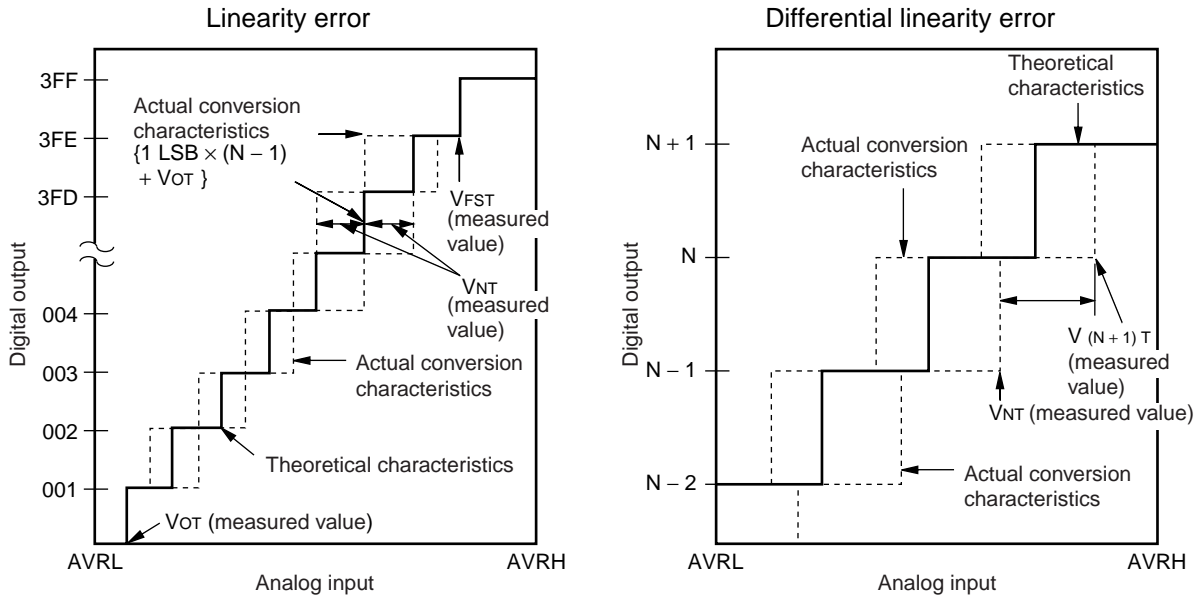

$$\text{Linearity error of digital output } N = \frac{V_{NT} - \{1 \text{ LSB} \times (N - 1) + V_{OT}\}}{1 \text{ LSB}} \text{ [LSB]}$$

$$\text{Differential linearity error of digital output } N = \frac{V_{(N+1)T} - V_{NT}}{1 \text{ LSB}} - 1 \text{ LSB [LSB]}$$

$$1 \text{ LSB} = \frac{V_{FST} - V_{OT}}{1022} \text{ [V]}$$

V_{OT} : Voltage at transition of digital output 000_H to 001_H.

V_{FST} : Voltage at transition of digital output 3FE_H to 3FF_H.

EXAMPLE CHARACTERISTICS

- "H" Level Output Voltage

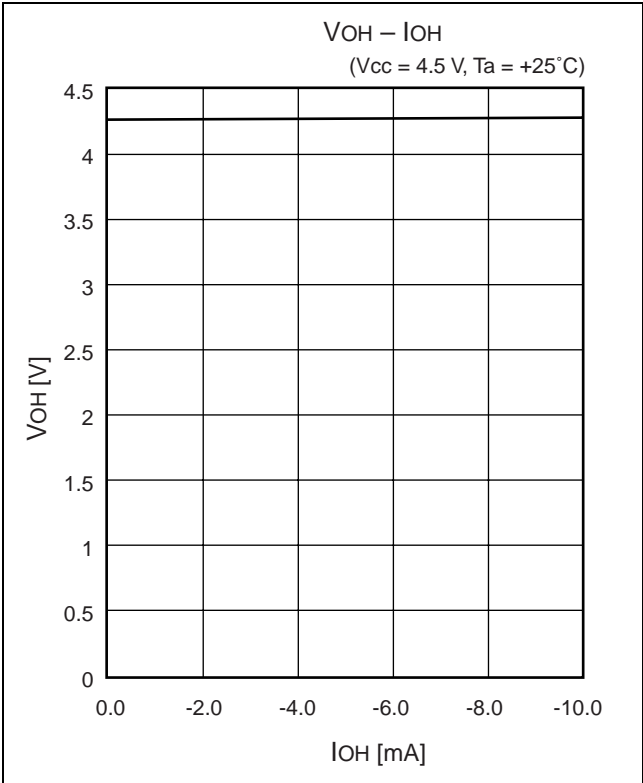

- "L" Level Output Voltage

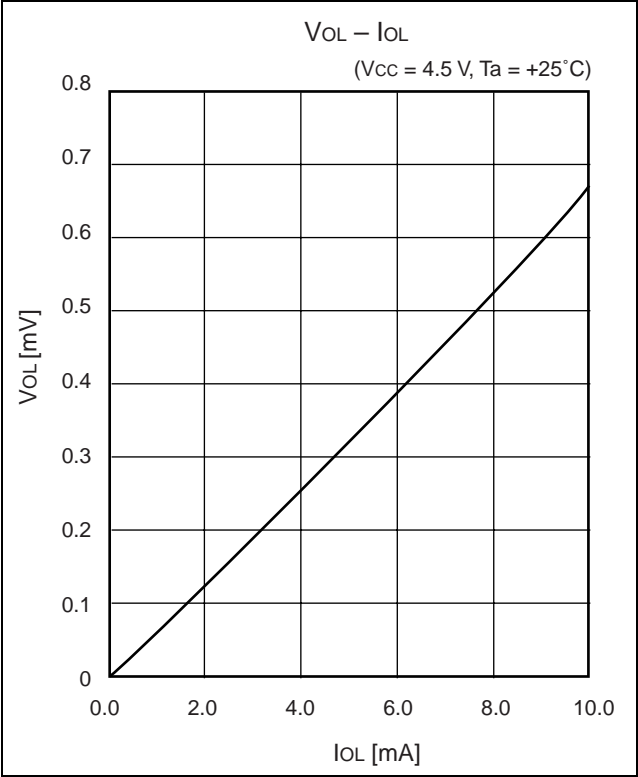

MB90440G Series

- Power Supply Current (FLASH)

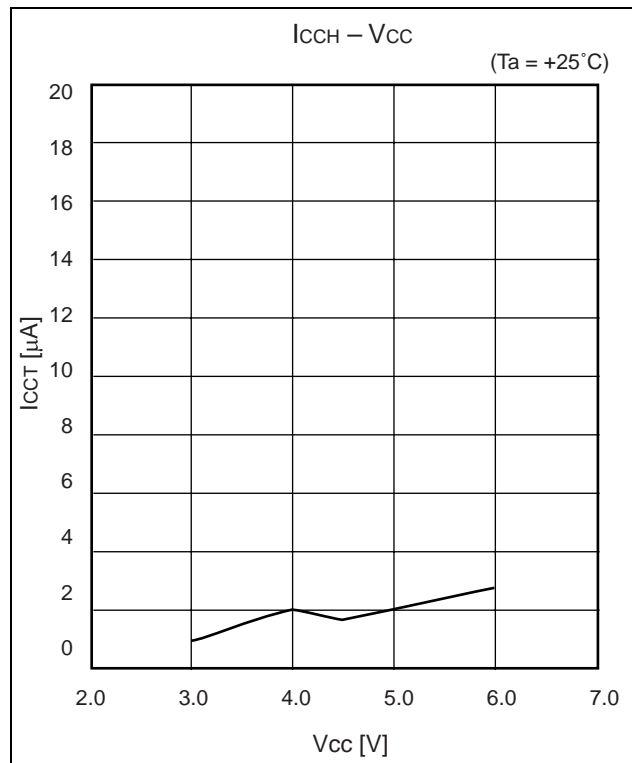
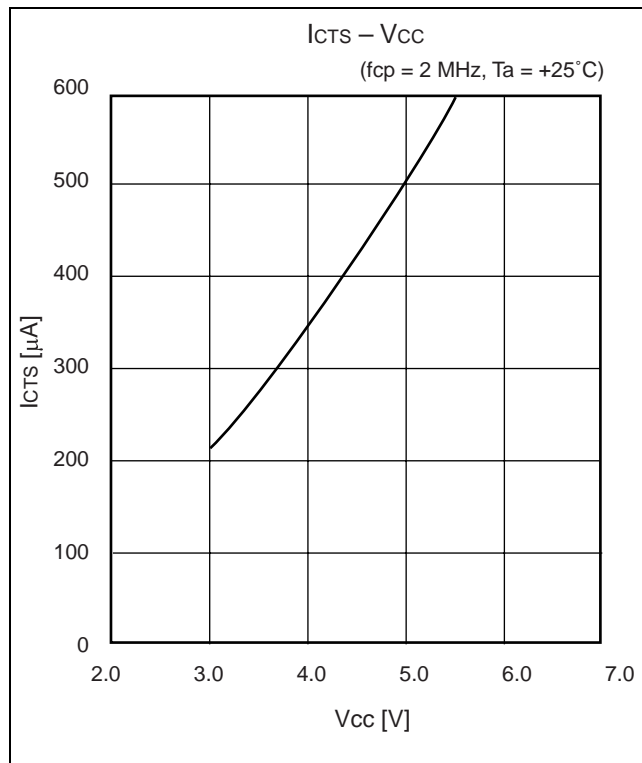
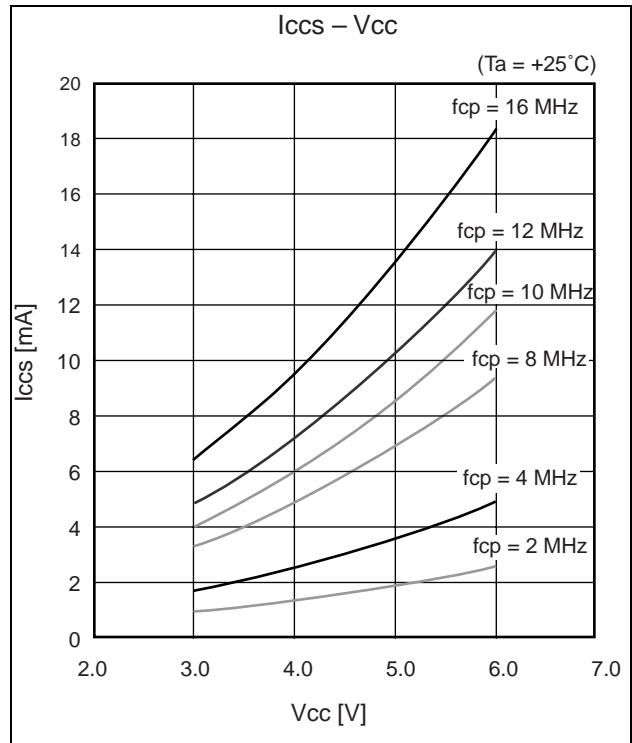
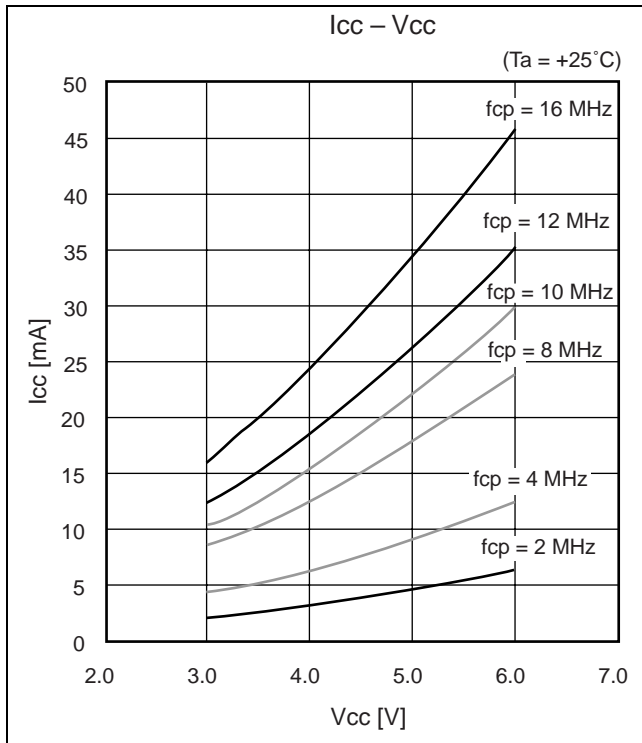

■ ORDERING INFORMATION

Part number	Package	Remarks
MB90443GPF (under development) MB90F443GPF	100-pin Plastic QFP (FPT-100P-M06)	
MB90V440GCR	256-pin Ceramic PGA (PGA-256C-A01)	For evaluation

MB90440G Series

PACKAGE DIMENSIONS

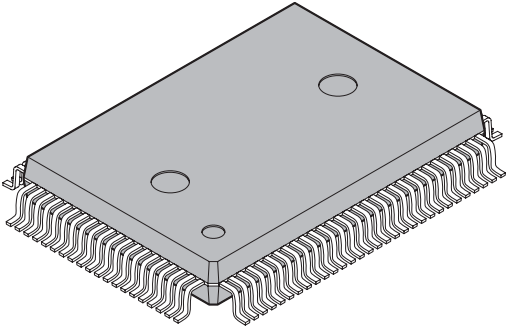
 <p>100-pin plastic QFP</p> <p>(FPT-100P-M06)</p>	Lead pitch	0.65 mm
	Package width package length	14.00 20.00 mm
	Lead shape	Gullwing
	Sealing method	Plastic mold
	Mounting height	3.35 mm MAX
	Code (Reference)	P-QFP100-14 20-0.65

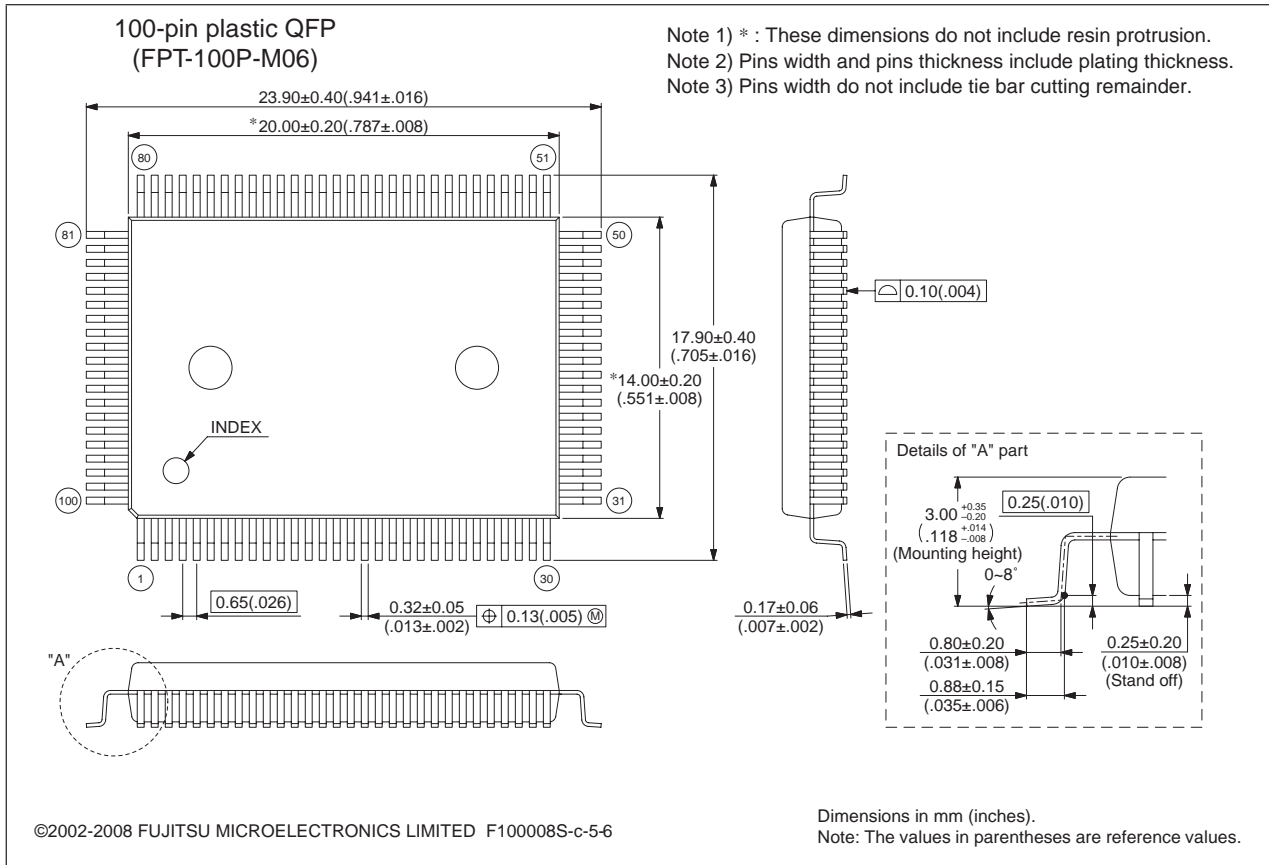

Please confirm the latest Package dimension by following URL.
<http://edevic.fujitsu.com/package/en-search/>

■ MAIN CHANGES IN THIS EDITION

Page	Section	Change Results
4	■ PRODUCT LINEUP	Changed the resource name. 16-bit I/O Timer → 16-bit Free-run Timer
6	■ PIN ASSIGNMENT	Changed the pin name. 35-pin : AVR + → AVRH 36-pin : AVR - → AVRL
17	■ BLOCK DIAGRAM	Changed the resource name. 16-bit I/O Timer → 16-bit Free-run Timer
32	■ INTERRUPT FACTORS, INTERRUPT VECTORS, INTERRUPT CONTROL REGISTER	Changed the interrupt cause name of the interrupt vector number #19. Input/output timer → 16-bit free-run timer
39	■ ELECTRICAL CHARACTERISTICS 4. AC Characteristics	Changed the "(1) Clock Timing". Added the limitation when PLL is used for the clock frequency.
44		Changed the symbol t_{RHLH} of (5) Bus Timing (Read). $\overline{RD} \downarrow \rightarrow \overline{RD} \uparrow$
49	■ ELECTRICAL CHARACTERISTICS 4. AC Characteristics (9) UART0/1, Serial I/O Timing	Changed the value of serial clock cycle time. Min : $8t_{CP} \rightarrow 4t_{CP}$

The vertical lines marked in the left side of the page show the changes.

MEMO

MEMO

MB90440G Series

FUJITSU MICROELECTRONICS LIMITED

Shinjuku Dai-Ichi Seimei Bldg., 7-1, Nishishinjuku 2-chome,
Shinjuku-ku, Tokyo 163-0722, Japan
Tel: +81-3-5322-3347 Fax: +81-3-5322-3387
<http://jp.fujitsu.com/fml/en/>

For further information please contact:

North and South America

FUJITSU MICROELECTRONICS AMERICA, INC.
1250 E. Arques Avenue, M/S 333
Sunnyvale, CA 94085-5401, U.S.A.
Tel: +1-408-737-5600 Fax: +1-408-737-5999
<http://www.fma.fujitsu.com/>

Asia Pacific

FUJITSU MICROELECTRONICS ASIA PTE. LTD.
151 Lorong Chuan,
#05-08 New Tech Park 556741 Singapore
Tel : +65-6281-0770 Fax : +65-6281-0220
<http://www.fmal.fujitsu.com/>

Europe

FUJITSU MICROELECTRONICS EUROPE GmbH
Pittlerstrasse 47, 63225 Langen, Germany
Tel: +49-6103-690-0 Fax: +49-6103-690-122
<http://emea.fujitsu.com/microelectronics/>

FUJITSU MICROELECTRONICS SHANGHAI CO., LTD.

Rm. 3102, Bund Center, No.222 Yan An Road (E),
Shanghai 200002, China
Tel : +86-21-6146-3688 Fax : +86-21-6335-1605
<http://cn.fujitsu.com/fmc/>

Korea

FUJITSU MICROELECTRONICS KOREA LTD.
206 Kosmo Tower Building, 1002 Daechi-Dong,
Gangnam-Gu, Seoul 135-280, Republic of Korea
Tel: +82-2-3484-7100 Fax: +82-2-3484-7111
<http://kr.fujitsu.com/fmk/>

FUJITSU MICROELECTRONICS PACIFIC ASIA LTD.

10/F., World Commerce Centre, 11 Canton Road,
Tsimshatsui, Kowloon, Hong Kong
Tel : +852-2377-0226 Fax : +852-2376-3269
<http://cn.fujitsu.com/fmc/en/>

Specifications are subject to change without notice. For further information please contact each office.

All Rights Reserved.

The contents of this document are subject to change without notice.

Customers are advised to consult with sales representatives before ordering.

The information, such as descriptions of function and application circuit examples, in this document are presented solely for the purpose of reference to show examples of operations and uses of FUJITSU MICROELECTRONICS device; FUJITSU MICROELECTRONICS does not warrant proper operation of the device with respect to use based on such information. When you develop equipment incorporating the device based on such information, you must assume any responsibility arising out of such use of the information.

FUJITSU MICROELECTRONICS assumes no liability for any damages whatsoever arising out of the use of the information.

Any information in this document, including descriptions of function and schematic diagrams, shall not be construed as license of the use or exercise of any intellectual property right, such as patent right or copyright, or any other right of FUJITSU MICROELECTRONICS or any third party or does FUJITSU MICROELECTRONICS warrant non-infringement of any third-party's intellectual property right or other right by using such information. FUJITSU MICROELECTRONICS assumes no liability for any infringement of the intellectual property rights or other rights of third parties which would result from the use of information contained herein.

The products described in this document are designed, developed and manufactured as contemplated for general use, including without limitation, ordinary industrial use, general office use, personal use, and household use, but are not designed, developed and manufactured as contemplated (1) for use accompanying fatal risks or dangers that, unless extremely high safety is secured, could have a serious effect to the public, and could lead directly to death, personal injury, severe physical damage or other loss (i.e., nuclear reaction control in nuclear facility, aircraft flight control, air traffic control, mass transport control, medical life support system, missile launch control in weapon system), or (2) for use requiring extremely high reliability (i.e., submersible repeater and artificial satellite).

Please note that FUJITSU MICROELECTRONICS will not be liable against you and/or any third party for any claims or damages arising in connection with above-mentioned uses of the products.

Any semiconductor devices have an inherent chance of failure. You must protect against injury, damage or loss from such failures by incorporating safety design measures into your facility and equipment such as redundancy, fire protection, and prevention of over-current levels and other abnormal operating conditions.

Exportation/release of any products described in this document may require necessary procedures in accordance with the regulations of the Foreign Exchange and Foreign Trade Control Law of Japan and/or US export control laws.

The company names and brand names herein are the trademarks or registered trademarks of their respective owners.

Edited: Business & Media Promotion Dept.