

# 16-bit Proprietary Microcontrollers

CMOS

## F<sup>2</sup>MC-16LX MB90560/565 Series

### MB90561 A/562A/F562B/V560/567/568/F568

#### ■ DESCRIPTION

The MB90560/565 series is a general-purpose 16-bit microcontroller designed for industrial, OA, and process control applications that require high-speed real-time processing. The device features a multi-function timer able to output a programmable waveform.

The microcontroller instruction set is based on the same AT architecture as the F<sup>2</sup>MC-8L and F<sup>2</sup>MC-16L families with additional instructions for high-level languages, extended addressing modes, enhanced signed multiplication and division instructions, and a complete range of bit manipulation instructions. The microcontroller has a 32-bit accumulator for processing long word (32-bit) data.

Note: F<sup>2</sup>MC is the abbreviation of FUJITSU Flexible Microcontroller.

#### ■ FEATURES

- **Clock**

- Internal oscillator circuit and PLL clock multiplication circuit
- Oscillation clock

Clock speed selectable from either the machine clock, main clock, or PLL clock. The main clock is the oscillation clock divided into 2 (0.5 MHz to 8 MHz for a 1 MHz to 16 MHz base oscillation) . The PLL clock is the oscillation clock multiplied by one to four (4 MHz to 16 MHz for a 4 MHz base oscillation) .

- Minimum instruction execution time : 62.5 ns (for oscillation = 4 MHz, PLL clock setting =  $\times 4$ ,  $V_{cc} = 5.0$  V)
- **Maximum CPU memory space : 16 MB**
  - 24-bit addressing
  - Bank addressing

(Continued)

The information for microcontroller supports is shown in the following homepage.  
Be sure to refer to the "Check Sheet" for the latest cautions on development.

#### **"Check Sheet" is seen at the following support page**

"Check Sheet" lists the minimal requirement items to be checked to prevent problems beforehand in system development.

<http://edevic.fujitsu.com/micom/en-support/>

# MB90560/565 Series

(Continued)

- **Instruction set**
  - Bit, byte, word, and long word data types
  - 23 different addressing modes
  - Enhanced calculation precision using a 32-bit accumulator
  - Enhanced signed multiplication and division instructions and RETI instruction
- **Instruction set designed for high level language (C) and multi-tasking**
  - Uses a system stack pointer
  - Symmetric instruction set and barrel shift instructions
- **Program patch function (2 address pointers) .**
- **4-byte instruction queue**
- **Interrupt function**
  - Priority levels are programmable
  - 32 interrupts
- **Data transfer function**
  - Extended intelligent I/O service function : Up to 16 channels
- **Low-power consumption modes**
  - Sleep mode (CPU operating clock stops.)
  - Timebase timer mode (Only oscillation clock and timebase timer continue to operate.)
  - Stop mode (Oscillation clock stops.)
  - CPU intermittent operation mode (The CPU operates intermittently at the specified interval.)
- **Package**
  - LQFP-64P (FTP-64P-M23 : 0.65 mm pin pitch)
  - QFP-64P (FTP-64P-M06 : 1.00 mm pin pitch)
  - SH-DIP (DIP-64P-M01 : 1.778 mm pin pitch)
- **Process : CMOS technology**

## ■ PERIPHERAL FUNCTIONS (RESOURCES)

- **I/O ports : 51 ports (max.)**
- **Timebase timer : 1 channel**
- **Watchdog timer : 1 channel**
- **16-bit reload timer : 2 channels**
- **Multi-function timer**
  - 16-bit free-run timer : 1 channel
  - Output compare : 6 channels  
Can output an interrupt request when a match occurs between the count in the 16-bit freerun timer and the value set in the compare register.
  - Input capture : 4 channels  
On detecting an active edge on the input signal from an external input pin, copies the count value of the 16-bit freerun timer to the input capture data register and generates an interrupt request.
  - 8/16-bit PPG timer (8-bit × 6 channels or 16-bit × 3 channels) The period and duty of the output pulse can be set by the program.
  - Waveform generator (8-bit timer : 3 channels)
- **UART : 2 channels**
  - Full-duplex, double-buffered (8-bit)
  - Can be set to asynchronous or clock synchronous serial transfer (I/O expansion serial) operation
- **DTP/external interrupt circuit (8 channels)**
  - External interrupts can activate the extended intelligent I/O service.
  - Generates interrupts in response to external interrupt inputs.

- **Delayed interrupt generation module**
  - Generates an interrupt request for task switching.
- **8/10-bit A/D converter : 8 channels**
  - 8-bit or 10-bit resolution selectable

# MB90560/565 Series

## ■ PRODUCT LINEUP

### 1. MB90560 Series

Part Number	MB90F562B	MB90562A	MB90561A	MB90V560
Classification	Internal flash memory product	Internal mask ROM product		Evaluation product
ROM size	64 Kbytes		32 Kbytes	No ROM
RAM size	2 Kbytes		1 Kbytes	4 Kbytes
Dedicated emulator power supply*	—		—	No
CPU functions	Number of instructions : 351 Minimum instruction execution time : 62.5 ns for a 4 MHz oscillation (with ×4 multiplier) Addressing modes : 23 modes Program patch function : 2 address pointers Maximum memory space : 16 Mbytes			
Ports	I/O ports (CMOS) : 51			
UART	Full-duplex, double-buffered Clock synchronous or asynchronous operation selectable Can be used as I/O serial Internal dedicated baud rate generator 2 channels			
16-bit reload timer	16-bit reload timer operation 2 channels			
Multi-function timer	16-bit free-run timer × 1 channel Output compare × 6 channels Input capture × 4 channels 8/16-bit PPG timer (8-bit × 6 channels or 16-bit × 3 channels) Waveform generator (8-bit timer × 3 channels) 3-phase waveform output, deadtime output			
8/10-bit A/D converter	8 channels (multiplexed input) 8-bit or 10-bit resolution selectable Conversion time : 6.13 μs (min.) (for maximum machine clock speed 16 MHz)			
DTP/external interrupts	8 channels (8 channels available, shared with A/D input) Interrupt triggers : “L” → “H” edge, “H” → “L” edge, “L” level, “H” level (selectable)			
Low power consumption modes	Sleep mode, timebase timer mode, stop mode, and CPU intermittent operation mode			
Process	CMOS			
Operating voltage	5 V ± 10%			

\* : DIP switch setting (S2) when using the emulation pod (MB2145-507) .

Refer to “2.7 Dedicated Emulator Power Supply” in the “MB2145-507 Hardware Manual” for details.

# MB90560/565 Series

## 2. MB90565 Series

Part Number	MB90F568	MB90568	MB90567
Classification	Internal flash memory product	Internal mask ROM product	
ROM size	128 Kbytes		96 Kbytes
RAM size	4 Kbytes		4 Kbytes
Dedicated emulator power supply*	—		—
CPU functions	Number of instructions : 351 Minimum instruction execution time : 62.5 ns for a 4 MHz oscillation (with ×4 multiplier) Addressing modes : 23 modes Program patch function : 2 address pointers Maximum memory space : 16 Mbytes		
Ports	I/O ports (CMOS) : 51		
UART	Full-duplex, double-buffered Clock synchronous or asynchronous operation selectable Can be used as I/O serial Internal dedicated baud rate generator 2 channels		
16-bit reload timer	16-bit reload timer operation 2 channels		
Multi-function timer	16-bit free-run timer × 1 channel Output compare × 6 channels Input capture × 4 channels 8/16-bit PPG timer (8-bit × 6 channels or 16-bit × 3 channels) Waveform generator (8-bit timer × 3 channels) 3-phase waveform output, deadtime output		
8/10-bit A/D converter	8 channels (multiplexed input) 8-bit or 10-bit resolution selectable Conversion time : 6.13 μs (min.) (for maximum machine clock speed 16 MHz)		
DTP/external interrupts	8 channels (8 channels available, shared with A/D input) Interrupt triggers : “L” → “H” edge, “H” → “L” edge, “L” level, “H” level (selectable)		
Low power consumption modes	Sleep mode, timebase timer mode, stop mode, and CPU intermittent operation mode		
Process	CMOS		
Operating voltage	3.3 V ± 0.3 V		

\* : DIP switch setting (S2) when using the emulation pod (MB2145-507) .

Refer to “2.7 Dedicated Emulator Power Supply” in the “MB2145-507 Hardware Manual” for details.

# MB90560/565 Series

## ■ PACKAGE AND CORRESPONDING PRODUCTS

Package	MB90561A	MB90562A	MB90F562B	MB90567	MB90568	MB90F568	MB90V560
FPT-64P-M23 (LQFP-0.65 mm)	○	○	○	○	○	○	×
FPT-64P-M06 (QFP-1.00 mm)	○	○	○	○	○	○	×
DIP-64P-M01 (SH-DIP)	○	○	○	×	×	×	×
PGA-256C-A01 (PGA)	×	×	×	×	×	×	○

○ : Available    × : Not available

Note : See the "Package Dimensions" section for details of each package.



# MB90560/565 Series

(TOP VIEW)

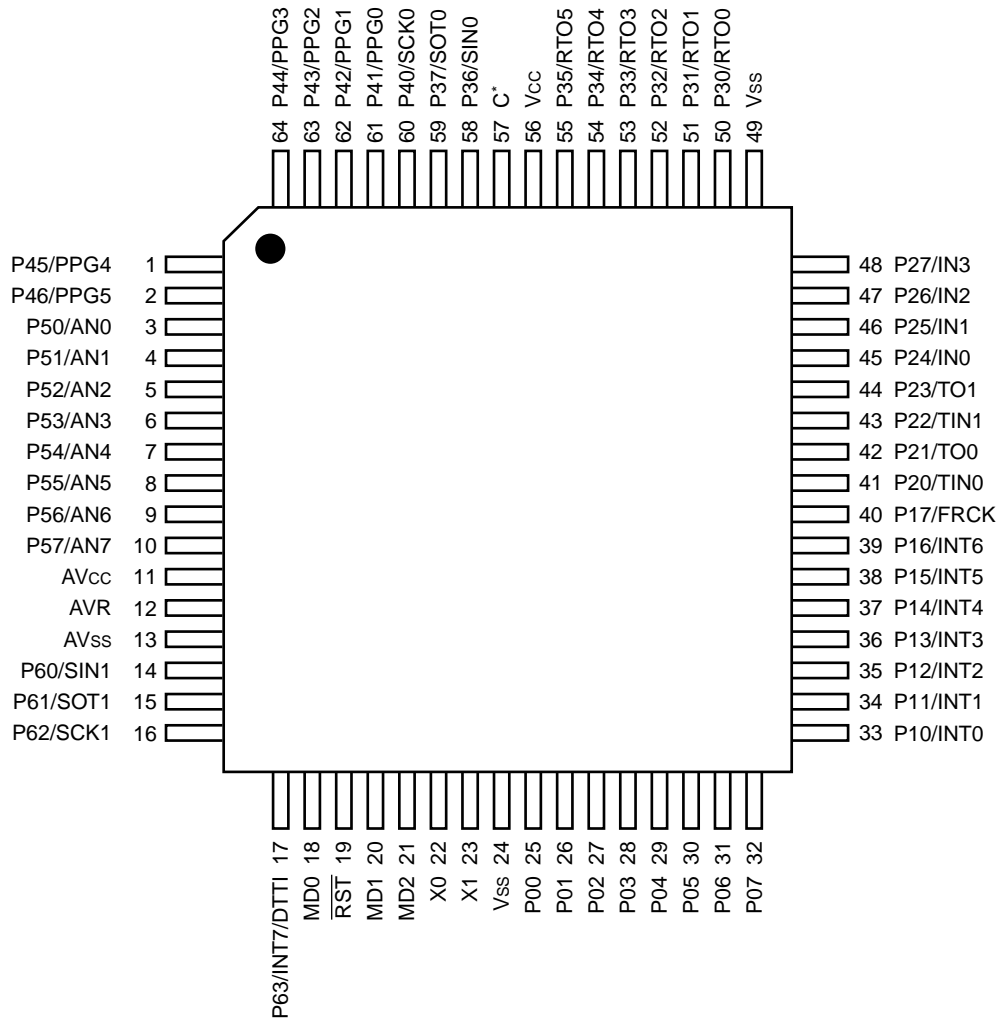

(FPT-64P-M23)

\* : N.C. on the MB90F568, MB90567, and MB90568.

(Continued)

# MB90560/565 Series

(Continued)

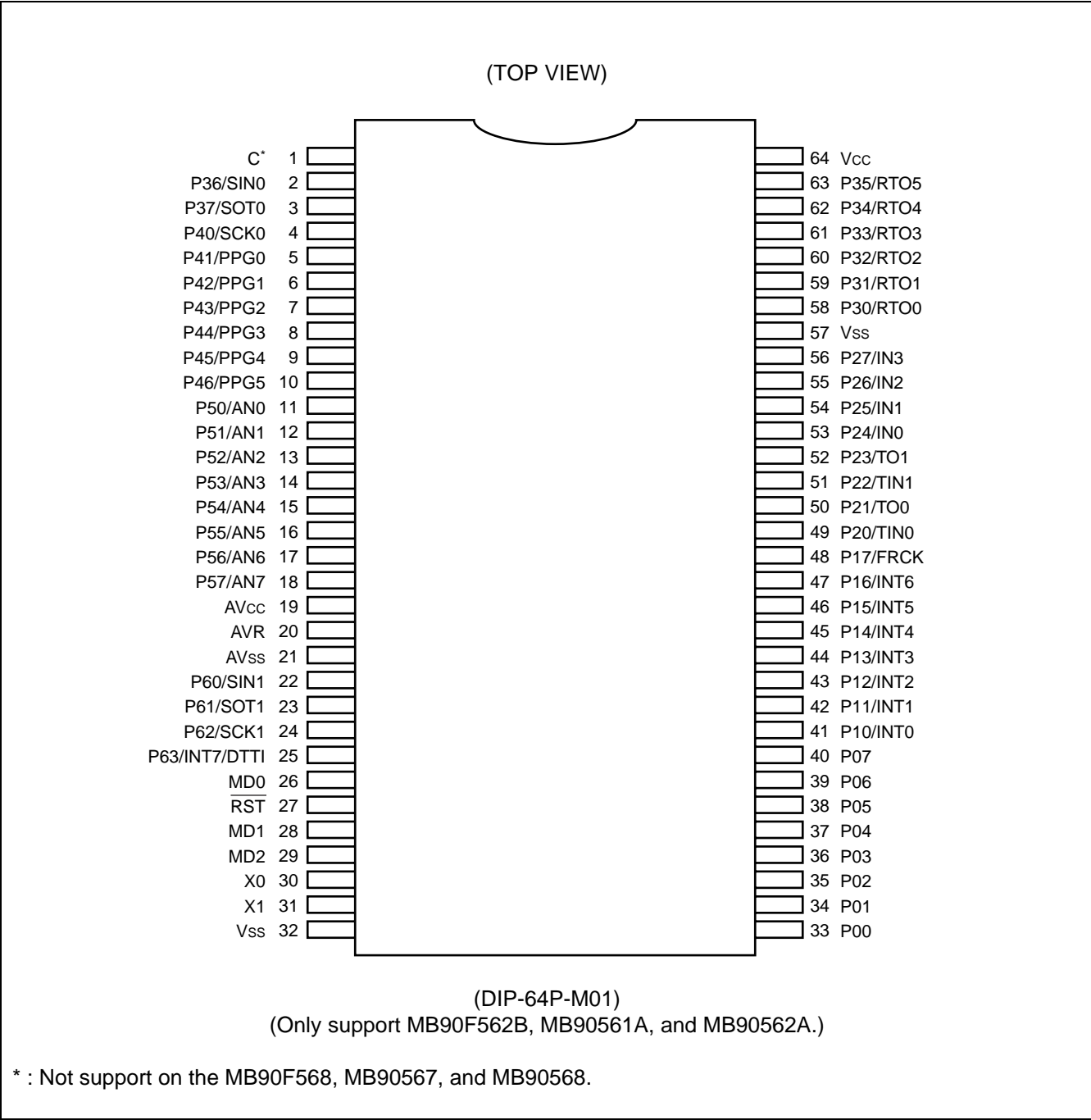

# MB90560/565 Series

## ■ PIN DESCRIPTIONS

Pin No.			Pin Name	Circuit Type <sup>*1</sup>	State/Function at Reset	Description
QFP <sup>*3</sup>	LQFP <sup>*4</sup>	SDIP <sup>*5</sup>				
23, 24	22, 23	30, 31	X0, X1	A	Oscillator	Connect oscillator to these pins. If using an external clock, leave X1 open.
20	19	27	$\overline{\text{RST}}$	H	Reset input	External reset input pin
26 to 33	25 to 32	33 to 40	P00 to P07	C	Port inputs (Hi-Z outputs)	I/O ports
34 to 40	33 to 39	41 to 47	P10 to P16	C		I/O ports
			INT0 to INT6			Can be used as interrupt request inputs ch0 to ch6. In standby mode, these pins can operate as inputs by setting the bits corresponding to EN0 to EN6 to "1" and setting as input ports. When used as a port, set the corresponding bits in the analog input enable register (ADER) to "port".
41	40	48	P17	C		I/O port
			FRCK			External clock input pin for the freerun timer. This pin can be used as an input when set as the clock input for the freerun timer and set as an input port. When used as a port, set the corresponding bit in the analog input enable register (ADER) to "port".
42	41	49	P20	D		I/O port
			TIN0			External clock input pin for reload timer ch0. This pin can be used as an input when set as the external clock input and set as an input port.
43	42	50	P21	D		I/O port
			TO0			Event output pin for reload timer ch0. Output operates when event output is enabled.
44	43	51	P22	D		I/O port
			TIN1			External clock input pin for reload timer ch1. This pin can be used as an input when set as the external clock input and set as an input port.
45	44	52	P23	D		I/O port
			TO1			Event output pin for reload timer ch1. Output operates when event output is enabled.
46 to 49	45 to 48	53 to 56	P24 to P27	D		I/O ports
			IN0 to IN3		Trigger input pins for input capture ch0 to ch3. These pins can be used as an input when set as an input capture trigger input and set as an input port.	

(Continued)

# MB90560/565 Series

Pin No.			Pin Name	Circuit Type <sup>1</sup>	State/Function at Reset	Description
QFP <sup>3</sup>	LQFP <sup>4</sup>	SDIP <sup>5</sup>				
51 to 56	50 to 55	58 to 63	P30 to P35	E	Port inputs (Hi-Z)	I/O ports
			RTO0 to RTO5			Event output pins for the output compare and waveform generator output pins. The pins output the specified waveform generated by the waveform generator. If not using waveform generation, these terminals enable output compare event output to use as output compare outputs. When used as a port, set the corresponding bits in the analog input enable register (ADER) to "port".
59	58	2	P36	D	Port inputs (Hi-Z)	I/O port
			SIN0			Serial data input pin for UART ch0. This pin is used continuously when input operation is enabled for UART ch0. In this case, do not use as a general input pin.
60	59	3	P37	D	Port inputs (Hi-Z)	I/O port
			SOT0			Serial data output pin for UART ch0. Output operates when UART ch0 output is enabled.
61	60	4	P40	D	Port inputs (Hi-Z)	I/O port
			SCK0			Serial clock I/O pin for UART ch0. Output operates when UART ch0 clock output is enabled.
62 to 64, 1 to 3	61 to 64, 1, 2	5 to 10	P41 to P46	D	Port inputs (Hi-Z)	I/O ports
			PPG0 to PPG5			Output pins for PPG ch0 to ch5. The outputs operate when output is enabled for PPG ch0 to ch5.
4 to 11	3 to 10	11 to 18	P50 to P57	F	Analog inputs	I/O ports
			AN0 to AN7			Analog input pins for the A/D converter. Input is available when the corresponding analog input enable register bits are set. (ADER : bit0 to bit7)
12	11	19	AV <sub>CC</sub>	—	Power supply input	V <sub>CC</sub> power supply input pin for A/D converter.
13	12	20	AVR	G	Reference voltage input	Reference voltage input pin for A/D converter. Ensure that the voltage does not exceed V <sub>CC</sub> .
14	13	21	AV <sub>SS</sub>	—	Power supply input	V <sub>SS</sub> power supply input pin for A/D converter.

(Continued)

# MB90560/565 Series

(Continued)

Pin No.			Pin Name	Circuit Type <sup>*1</sup>	State/Function at Reset	Description
QFP <sup>*3</sup>	LQFP <sup>*4</sup>	SDIP <sup>*5</sup>				
15	14	22	P60	D	Port input (Hi-Z)	I/O port
			SIN1			Serial data input pin for UART ch1. This pin is used continuously when input operation is enabled for UART ch1. In this case, do not use as a general input pin.
16	15	23	P61	D		I/O port
			SOT1			Serial data output pin for UART ch1. Output operates when UART ch1 output is enabled.
17	16	24	P62	D		I/O port
			SCK1			Serial clock I/O pin for UART ch1. Output operates when UART ch1 clock output is enabled.
18	17	25	P63	D		I/O port
			INT7			This pin can be used as interrupt request input ch7. In standby mode, this pin can operate as an input by setting the bit corresponding to EN7 to "1" and setting as an input port.
			DTTI			Fixed pin level input pin when RTO0 to RTO5 pins are used. Input is enabled when "input enabled" set in the waveform generator.
58	57	1	C <sup>*2</sup>	—		Capacitor pin, power supply input
19	18	26	MD0	B	Mode input pins	Input pin for setting the operation mode. Connect directly to V <sub>CC</sub> or V <sub>SS</sub> .
21	20	28	MD1	B		Input pin for setting the operation mode. Connect directly to V <sub>CC</sub> or V <sub>SS</sub> .
22	21	29	MD2	B/I		Input pin for setting the operation mode. Connect directly to V <sub>SS</sub> . Mask ROM products have a built-in pull-up resistor and its circuit type is "I".
25, 50	24, 49	32, 57	V <sub>SS</sub>	—	Power supply inputs	Power supply (GND) input pin
57	56	64	V <sub>CC</sub>	—		MB90560 series is power supply (5 V) input pin MB90565 series is power supply (3.3 V) input pin

\*1 : See "I/O CIRCUITS" for details of the circuit types.

\*2 : N.C. on the MB90F568, MB90567, and MB90568

\*3 : FPT-64P-M06

\*4 : FPT-64P-M23

\*5 : DIP-64P-M01

## I/O CIRCUITS

Type	Circuit	Remarks
A		<ul style="list-style-type: none"> <li>Oscillation circuit</li> <li>Internal oscillation feedback resistor (<math>R_f</math>)</li> </ul>
B		<ul style="list-style-type: none"> <li>CMOS hysteresis input</li> </ul>
C		<ul style="list-style-type: none"> <li>CMOS hysteresis I/O pin with pull-up control</li> <li>CMOS output</li> <li>CMOS hysteresis input (with input cut-off function in standby mode)</li> <li>Internal pull-up resistor (<math>R_p</math>)</li> </ul> <p>&lt; Note &gt;</p> <ul style="list-style-type: none"> <li>The pull-up resistor is active when the port is set as an input.</li> </ul>
D		<ul style="list-style-type: none"> <li>CMOS hysteresis I/O pin</li> <li>CMOS output</li> <li>CMOS hysteresis input (with input cut-off function in standby mode)</li> </ul> <p>&lt; Notes &gt;</p> <ul style="list-style-type: none"> <li>The I/O port output and internal resource output share the same output buffer.</li> <li>The I/O port input and internal resource input share the same input buffer.</li> </ul>

(Continued)

# MB90560/565 Series

(Continued)

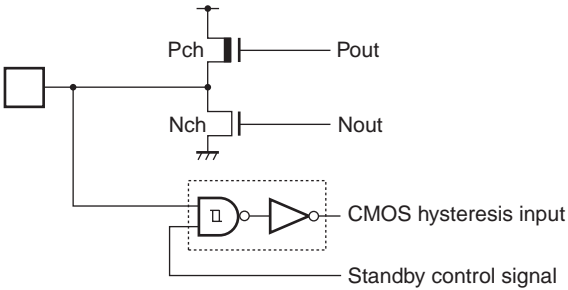
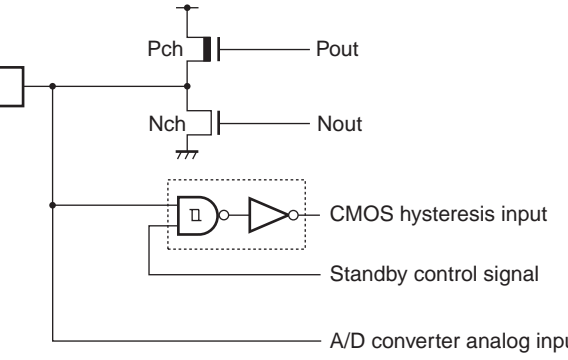
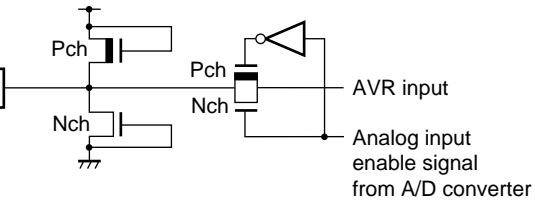
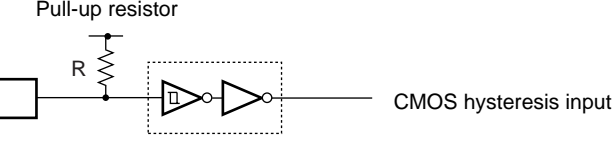
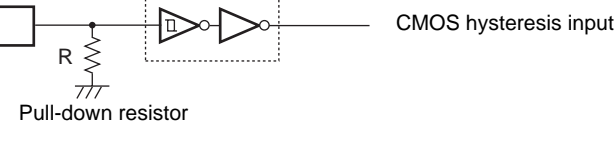
Type	Circuit	Remarks
E		<ul style="list-style-type: none"> <li>• CMOS I/O pin</li> <li>• CMOS output</li> <li>• CMOS hysteresis input (with input cut-off function in standby mode)</li> </ul> <p>&lt; <math>I_{OL} = 12\text{ mA}</math> &gt;</p>
F		<ul style="list-style-type: none"> <li>• Analog/CMOS hysteresis I/O pin</li> <li>• CMOS output</li> <li>• CMOS hysteresis input (with input cut-off function in standby mode)</li> <li>• Analog input (Analog input to A/D converter is enabled when "1" is set in the corresponding bit in the analog input enable register (ADER) .)</li> <li>• The I/O port output and internal resource output share the same output buffer.</li> <li>• The I/O port input and internal resource input share the same input buffer.</li> </ul>
G		<ul style="list-style-type: none"> <li>• A/D converter (AVR) voltage input pin</li> </ul>
H		<ul style="list-style-type: none"> <li>• CMOS hysteresis input</li> <li>• Pull-up resistor</li> </ul>
I		<ul style="list-style-type: none"> <li>• CMOS hysteresis input</li> <li>• Pull-down resistor</li> </ul>

## ■ HANDLING DEVICES

Take note of the following nine points when handling devices :

- Do not exceed maximum rated voltage (to prevent latch-up)
- Supply voltage stability
- Power-on precautions
- Treatment of unused pins
- Treatment of A/D converter power supply pins
- Notes on using an external clock
- Power supply pins
- Sequence for connecting and disconnecting the A/D converter power supply and analog input pins
- Notes on using the DIV A, Ri and DIVW A, RWi instructions

### • Device Handling Precautions

#### (1) Do not exceed maximum rated voltage (to prevent latch-up)

Do not apply a voltage greater than  $V_{CC}$  or less than  $V_{SS}$  to the MB90560/565 series input or output pins. Also ensure that the voltage between  $V_{CC}$  and  $V_{SS}$  does not exceed the rating. Applying a voltage in excess of the ratings may result in latch-up causing thermal damage to circuit elements.

Similarly, when connecting or disconnecting the power to the analog power supply ( $AV_{CC}$ ,  $AVR$ ) and analog inputs ( $AN0$  to  $AN7$ ), ensure that the analog power supply voltages do not exceed the digital voltage ( $V_{CC}$ ).

#### (2) Supply voltage stability

Rapid changes in the  $V_{CC}$  supply voltage may cause the device to misoperate. Accordingly, ensure that the  $V_{CC}$  power supply is stable. The standard for power supply voltage stability is a peak-to-peak  $V_{CC}$  ripple voltage at the supply frequency (50 to 60 Hz) of 10% or less of  $V_{CC}$  and a transient fluctuation in the voltage of 0.1 V/ms or less when turning the power supply on or off.

#### (3) Power-on precautions

To prevent misoperation of the internal regulator circuit, ensure that the voltage rise time at power-on is at least 50  $\mu$ s (between 0.2 V to 2.7 V).

#### (4) Treatment of unused pins

Leaving unused input pins unconnected can cause misoperation or permanent damage to the device due to latchup. Always pull-up or pull-down unused pins using a 2 k $\Omega$  or larger resistor.

If some I/O pins are unused, either set as outputs and leave open circuit or set as inputs and treat in the same way as input pins.

#### (5) Treatment of A/D converter power supply pins

If not using the A/D converter, connect the analog power supply pins so that  $AV_{CC} = AVR = V_{CC}$  and  $AV_{SS} = V_{SS}$ .

#### (6) Notes on using an external clock

Even if using an external clock, an oscillation stabilization delay time occurs after a power-on reset and when recovering from stop mode in the same way as when an oscillator is connected. When using an external clock, drive the X0 pin only and leave the X1 pin open.

# MB90560/565 Series

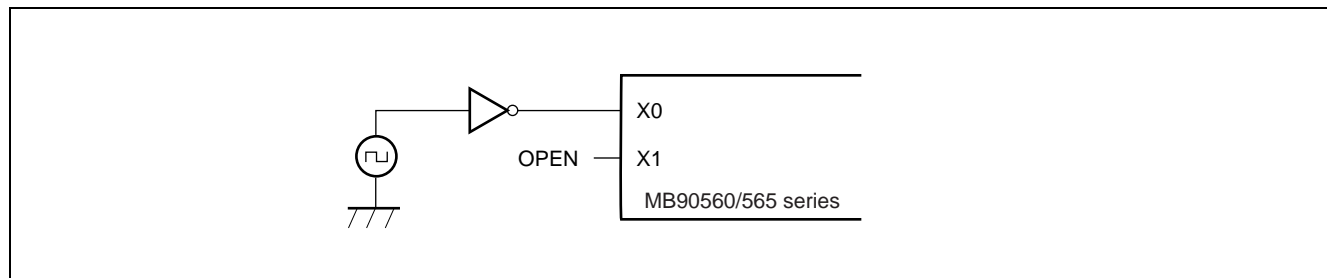

Example of using an external clock

## (7) Power supply pins

The multiple  $V_{CC}$  and  $V_{SS}$  pins are connected together in the internal device design so as to prevent misoperation such as latch-up. However, always connect all  $V_{CC}$  and  $V_{SS}$  pins to the same potential externally to minimize spurious radiation, prevent misoperation of strobe signals due to increases in the ground level, and maintain the overall output current rating.

Also, ensure that the impedance of the  $V_{CC}$  and  $V_{SS}$  connections to the power supply is as low as possible. To minimize these problems, connect a bypass capacitor of approximately  $0.1 \mu\text{F}$  between  $V_{CC}$  and  $V_{SS}$ . Connect the capacitor close to the  $V_{CC}$  and  $V_{SS}$  pins.

## (8) Sequence for connecting and disconnecting power supply

Do not apply voltage to the A/D converter power supply pins ( $AV_{CC}$ , AVR,  $AV_{SS}$ ) or analog inputs (AN0 to AN7) until the digital power supply ( $V_{CC}$ ) is turned on. When turning the device off, turn off the digital power supply after disconnecting the A/D converter power supply and analog inputs. When turning the power on or off, ensure that AVR does not exceed  $AV_{CC}$ .

When using the I/O ports that share pins with the analog inputs, ensure that the input voltage does not exceed  $AV_{CC}$  (turning the analog and digital power supplies on and off simultaneously is OK).

## (9) Conditions when output from ports 0 and 1 is undefined

After turning on the power supply, the outputs from ports 0 and 1 are undefined during the oscillation stabilization delay time controlled by the regulator circuit (during the power-on reset) if the  $\overline{\text{RST}}$  pin level is "H". When the  $\overline{\text{RST}}$  pin level is "L", ports 0 and 1 go to high impedance.

Figures 1 and 2 show the timing (for the MB90F562B and MB90V560).

Note that this undefined output period does not occur on products without an internal regulator circuit as these products do not have an oscillation stabilization delay time.

(MB90561A, MB90562A, MB90F568, MB90567 and MB90568)

• **Figure 1** Timing chart for undefined output from ports 0 and 1 (When  $\overline{\text{RST}}$  pin level is "H")

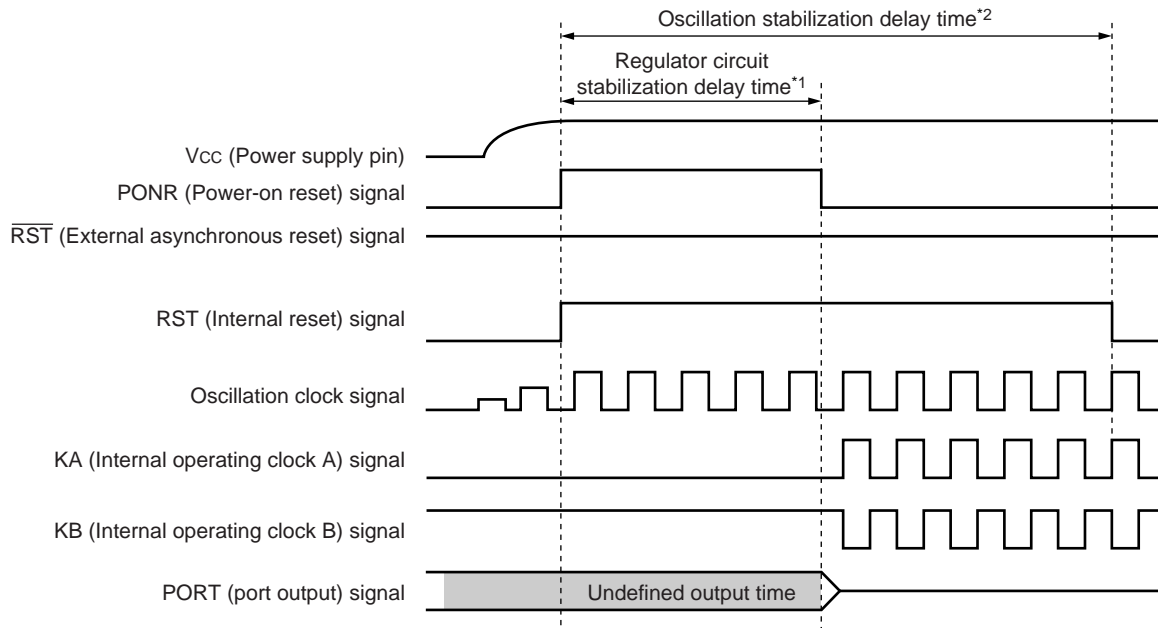

\*1 : Regulator circuit oscillation stabilization delay time :

$2^{17}/\text{Oscillation clock frequency}$  (approx. 8.19 ms for a 16 MHz oscillation clock frequency)

\*2 : Oscillation stabilization delay time :

$2^{18}/\text{Oscillation clock frequency}$  (approx. 16.38 ms for a 16 MHz oscillation clock frequency)

# MB90560/565 Series

• Figure 2 Timing chart for ports 0 and 1 going to high impedance state (When  $\overline{RST}$  pin level is "L")

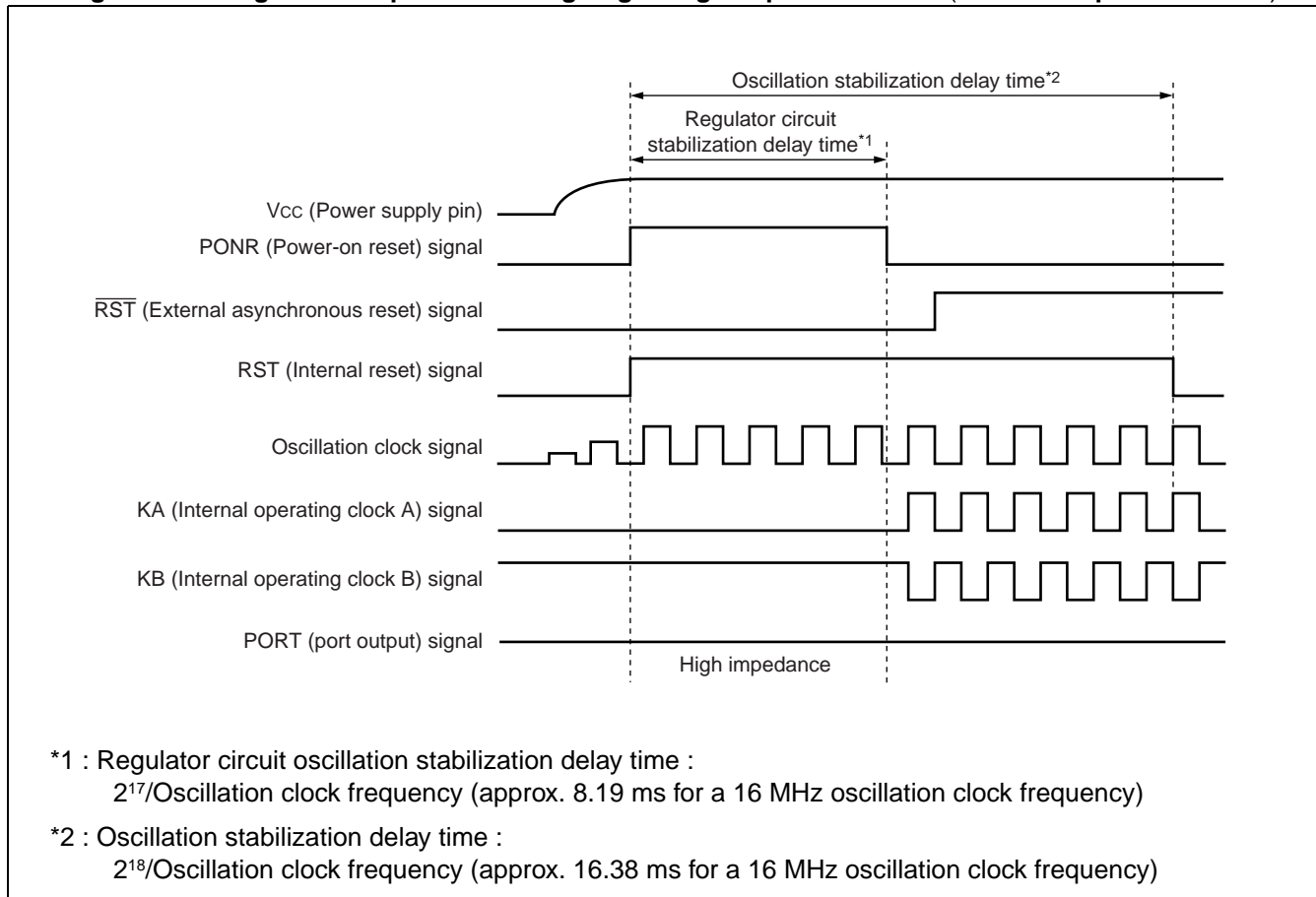

## (10) Notes on using the DIV A, Ri and DIVW A, RWi instructions

The location in which the remainder value produced by the signed division instructions "DIV A, Ri" and "DIVW A, RWi" is stored depends on the bank register. The remainder is stored in an address in the memory bank specified in the bank register.

Set the bank register to "00H" when using the "DIV A, Ri" and "DIVW A, RWi" instructions.

## (11) Notes on using REALOS

The extended intelligent I/O service (EI<sup>2</sup>OS) cannot be used when using REALOS.

## (12) Caution on Operations during PLL Clock Mode

If the PLL clock mode is selected in the microcontroller, it may attempt to continue the operation using the free-running frequency of the self oscillation circuit in the PLL circuitry even if the oscillator is out of place or the clock input is stopped. Performance of this operation, however, cannot be guaranteed.

## ■ BLOCK DIAGRAM

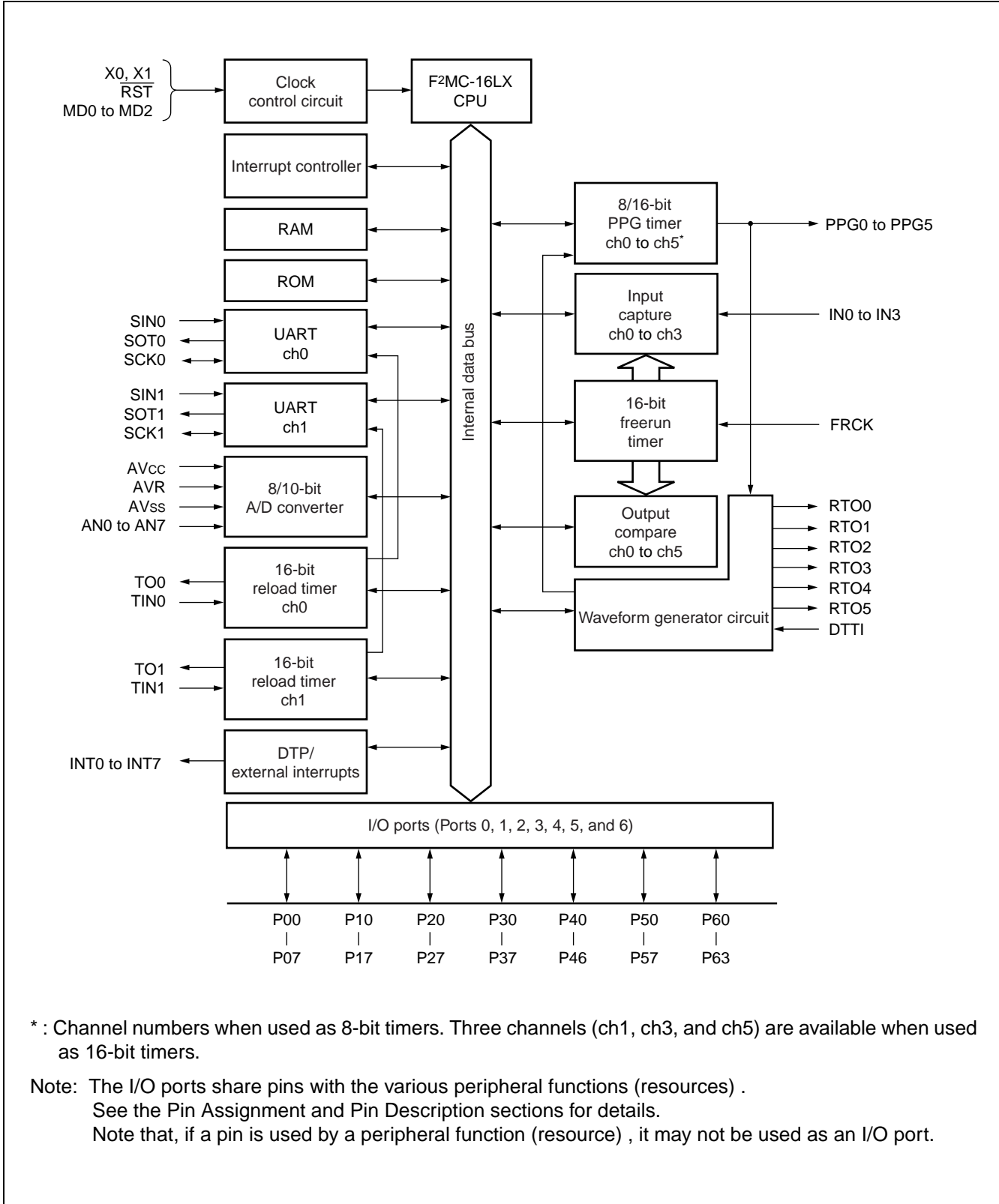

\* : Channel numbers when used as 8-bit timers. Three channels (ch1, ch3, and ch5) are available when used as 16-bit timers.

Note: The I/O ports share pins with the various peripheral functions (resources) . See the Pin Assignment and Pin Description sections for details.

Note that, if a pin is used by a peripheral function (resource) , it may not be used as an I/O port.

# MB90560/565 Series

## MEMORY MAP

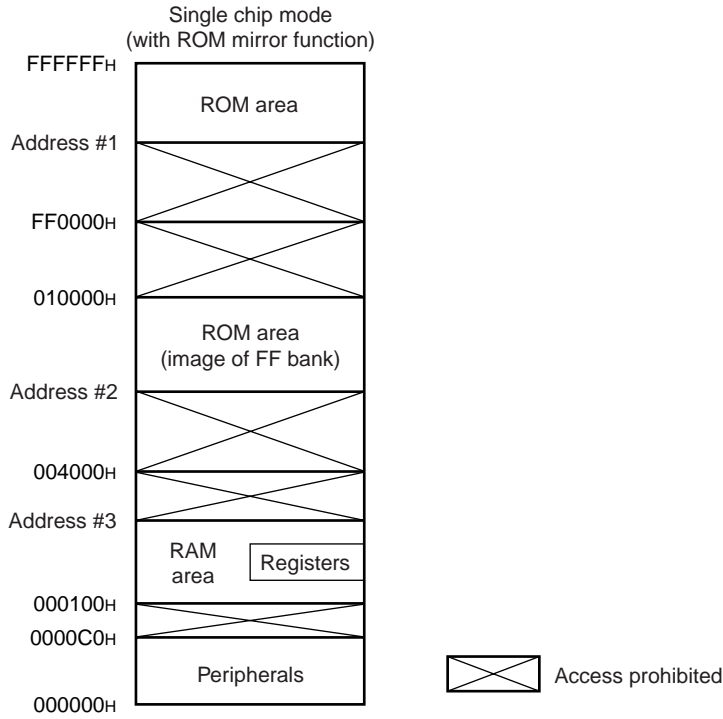

Part No.	Address#1	Address#2	Address#3
MB90561A	FF8000H	008000H	000500H
MB90562A	FF0000H	004000H	000900H
MB90F562B	FF0000H	004000H	000900H
MB90567	FE8000H	004000H	001100H
MB90568	FE0000H	004000H	001100H
MB90F568	FE0000H	004000H	001100H
MB90V560	FE0000H*	004000H*	001100H

\* : "V" products do not contain internal ROM. Treat this address as the ROM decode area used by the tools.

Memory map of MB90560/565 series

- Notes :
- When specified in the ROM mirror function register, the upper part of 00 bank ("004000H to 00FFFFH") contains a mirror of the data in the upper part of FF bank ("FF4000H to FFFFFFFH").
  - See "10. ROM Mirror Function Selection Module" in the Peripheral Functions section for details of the ROM mirror function settings.

- Remarks :
- The ROM mirror function is provided so the C compiler's small memory model can be used.
  - The lower 16 bits of the FF bank and 00 bank addresses are the same. However, as the FF bank ROM area exceeds 48 KBytes, the entire ROM data area cannot be mirrored in 00 bank.
  - When using the C compiler's small memory model, locating data tables in the area "FF4000H to FFFFFFFH" makes the image of the data visible in the "004000H to 00FFFFH" area. This means that data tables located in ROM can be referenced without needing to declare far pointers.

# MB90560/565 Series

## ■ I/O MAP

Address	Abbreviated Register Name	Register name	Read/Write	Resource Name	Initial Value
00000H	PDR0	Port 0 data register	R/W	Port 0	XXXXXXXX <sub>B</sub>
00001H	PDR1	Port 1 data register	R/W	Port 1	XXXXXXXX <sub>B</sub>
00002H	PDR2	Port 2 data register	R/W	Port 2	XXXXXXXX <sub>B</sub>
00003H	PDR3	Port 3 data register	R/W	Port 3	XXXXXXXX <sub>B</sub>
00004H	PDR4	Port 4 data register	R/W	Port 4	XXXXXXXX <sub>B</sub>
00005H	PDR5	Port 5 data register	R/W	Port 5	XXXXXXXX <sub>B</sub>
00006H	PDR6	Port 6 data register	R/W	Port 6	XXXXXXXX <sub>B</sub>
00007H to 0000FH	Access prohibited				
000010H	DDR0	Port 0 direction register	R/W	Port 0	00000000 <sub>B</sub>
000011H	DDR1	Port 1 direction register	R/W	Port 1	00000000 <sub>B</sub>
000012H	DDR2	Port 2 direction register	R/W	Port 2	00000000 <sub>B</sub>
000013H	DDR3	Port 3 direction register	R/W	Port 3	00000000 <sub>B</sub>
000014H	DDR4	Port 4 direction register	R/W	Port 4	X0000000 <sub>B</sub>
000015H	DDR5	Port 5 direction register	R/W	Port 5	00000000 <sub>B</sub>
000016H	DDR6	Port 6 direction register	R/W	Port 6	XXXX0000 <sub>B</sub>
000017H	ADER	Analog input enable register	R/W	Port 5, A/D converter	11111111 <sub>B</sub>
000018H to 00001FH	Access prohibited				
000020H	SMR0	Mode register ch0	R/W	UART0	0000X00 <sub>B</sub>
000021H	SCR0	Control register ch0	W, R/W		00000100 <sub>B</sub>
000022H	SIDR0	Input data register ch0	R		XXXXXXXX <sub>B</sub>
	SODR0	Output data register ch0	W		
000023H	SSR0	Status register ch0	R, R/W		00001000 <sub>B</sub>
000024H	SMR1	Mode register ch1	R/W	UART1	0000X00 <sub>B</sub>
000025H	SCR1	Control register ch1	W, R/W		00000100 <sub>B</sub>
000026H	SIDR1	Input data register ch1	R		XXXXXXXX <sub>B</sub>
	SODR1	Output data register ch1	W		
000027H	SSR1	Status register ch1	R, R/W		00001000 <sub>B</sub>
000028H	Access prohibited				
000029H	CDCR0	Communication prescaler control register ch0	R/W	Communication prescaler	0XXX0000 <sub>B</sub>

(Continued)

# MB90560/565 Series

Address	Abbreviated Register Name	Register name	Read/Write	Resource Name	Initial Value
00002A <sub>H</sub>	Access prohibited				
00002B <sub>H</sub>	CDCR1	Communication prescaler control register ch1	R/W	Communication prescaler	0 XXX 0 0 0 0 <sub>B</sub>
00002C <sub>H</sub> to 00002F <sub>H</sub>	Access prohibited				
000030 <sub>H</sub>	ENIR	DTP/external interrupt enable register	R/W	DTP/external interrupts	0 0 0 0 0 0 0 0 <sub>B</sub>
000031 <sub>H</sub>	EIRR	DTP/external interrupt request register	R/W		XXXXXXXX <sub>B</sub>
000032 <sub>H</sub>	ELVR	Request level setting register (lower)	R/W		0 0 0 0 0 0 0 0 <sub>B</sub>
000033 <sub>H</sub>		Request level setting register (upper)	R/W	0 0 0 0 0 0 0 0 <sub>B</sub>	
000034 <sub>H</sub>	ADCS0	A/D control status register (lower)	R/W	8/10-bit A/D converter	0 0 0 0 0 0 0 0 <sub>B</sub>
000035 <sub>H</sub>	ADCS1	A/D control status register (upper)	W, R/W		0 0 0 0 0 0 0 0 <sub>B</sub>
000036 <sub>H</sub>	ADCR0	A/D data register (lower)	R		XXXXXXXX <sub>B</sub>
000037 <sub>H</sub>	ADCR1	A/D data register (upper)	R, W		0 0 0 0 0 XXX <sub>B</sub>
000038 <sub>H</sub>	PRL0	PPG reload register ch0 (lower)	R/W	8/16-bit PPG timer	XXXXXXXX <sub>B</sub>
000039 <sub>H</sub>	PRLH0	PPG reload register ch0 (upper)	R/W		XXXXXXXX <sub>B</sub>
00003A <sub>H</sub>	PRL1	PPG reload register ch1 (lower)	R/W		XXXXXXXX <sub>B</sub>
00003B <sub>H</sub>	PRLH1	PPG reload register ch1 (upper)	R/W		XXXXXXXX <sub>B</sub>
00003C <sub>H</sub>	PPGC0	PPG control register ch0 (lower)	R/W		0 0 0 0 0 0 0 1 <sub>B</sub>
00003D <sub>H</sub>	PPGC1	PPG control register ch1 (upper)	R/W		0 0 0 0 0 0 0 1 <sub>B</sub>
00003E <sub>H</sub>	PCS01	PPG clock control register ch0, ch1	R/W		0 0 0 0 0 XX <sub>B</sub>
00003F <sub>H</sub>	Access prohibited				
000040 <sub>H</sub>	PRL2	PPG reload register ch2 (lower)	R/W	8/16-bit PPG timer	XXXXXXXX <sub>B</sub>
000041 <sub>H</sub>	PRLH2	PPG reload register ch2 (upper)	R/W		XXXXXXXX <sub>B</sub>
000042 <sub>H</sub>	PRL3	PPG reload register ch3 (lower)	R/W		XXXXXXXX <sub>B</sub>
000043 <sub>H</sub>	PRLH3	PPG reload register ch3 (upper)	R/W		XXXXXXXX <sub>B</sub>
000044 <sub>H</sub>	PPGC2	PPG control register ch2 (lower)	R/W		0 0 0 0 0 0 0 1 <sub>B</sub>
000045 <sub>H</sub>	PPGC3	PPG control register ch3 (upper)	R/W		0 0 0 0 0 0 0 1 <sub>B</sub>
000046 <sub>H</sub>	PCS23	PPG clock control register ch2, ch3	R/W		0 0 0 0 0 XX <sub>B</sub>
000047 <sub>H</sub>	Access prohibited				
000048 <sub>H</sub>	PRL4	PPG reload register ch4 (lower)	R/W	8/16-bit PPG timer	XXXXXXXX <sub>B</sub>
000049 <sub>H</sub>	PRLH4	PPG reload register ch4 (upper)	R/W		XXXXXXXX <sub>B</sub>
00004A <sub>H</sub>	PRL5	PPG reload register ch5 (lower)	R/W		XXXXXXXX <sub>B</sub>
00004B <sub>H</sub>	PRLH5	PPG reload register ch5 (upper)	R/W		XXXXXXXX <sub>B</sub>
00004C <sub>H</sub>	PPGC4	PPG control register ch4 (lower)	R/W		0 0 0 0 0 0 0 1 <sub>B</sub>

(Continued)

# MB90560/565 Series

Address	Abbreviated Register Name	Register name	Read/Write	Resource Name	Initial Value
00004D <sub>H</sub>	PPGC5	PPG control register ch5 (upper)	R/W	8/16-bit PPG timer	0 0 0 0 0 0 1 <sub>B</sub>
00004E <sub>H</sub>	PCS45	PPG clock control register ch4, ch5	R/W		0 0 0 0 0 0 X <sub>B</sub>
00004F <sub>H</sub>	Access prohibited				
000050 <sub>H</sub>	TMRR0	8-bit reload register ch0	R/W	Waveform generator	XXXXXXXX <sub>B</sub>
000051 <sub>H</sub>	DTCR0	8-bit timer control register ch0	R/W		0 0 0 0 0 0 0 <sub>B</sub>
000052 <sub>H</sub>	TMRR1	8-bit reload register ch1	R/W		XXXXXXXX <sub>B</sub>
000053 <sub>H</sub>	DTCR1	8-bit timer control register ch1	R/W		0 0 0 0 0 0 0 <sub>B</sub>
000054 <sub>H</sub>	TMRR2	8-bit reload register ch2	R/W		XXXXXXXX <sub>B</sub>
000055 <sub>H</sub>	DTCR2	8-bit timer control register ch2	R/W		0 0 0 0 0 0 0 <sub>B</sub>
000056 <sub>H</sub>	SIGCR	Waveform control register	R/W		0 0 0 0 0 0 0 <sub>B</sub>
000057 <sub>H</sub>	Access prohibited				
000058 <sub>H</sub>	CPCLR	Compare clear register (lower)	R/W	16-bit freerun timer	XXXXXXXX <sub>B</sub>
000059 <sub>H</sub>		Compare clear register (upper)	R/W		XXXXXXXX <sub>B</sub>
00005A <sub>H</sub>	TCDT	Timer data register (lower)	R/W		0 0 0 0 0 0 0 <sub>B</sub>
00005B <sub>H</sub>		Timer data register (upper)	R/W		0 0 0 0 0 0 0 <sub>B</sub>
00005C <sub>H</sub>	TCCS	Timer control/status register (lower)	R/W		0 0 0 0 0 0 0 <sub>B</sub>
00005D <sub>H</sub>		Timer control/status register (upper)	R/W		0 X X 0 0 0 0 0 <sub>B</sub>
00005E <sub>H</sub>	Access prohibited				
00005F <sub>H</sub>	Access prohibited				
000060 <sub>H</sub>	IPCP0	Input capture data register ch0 (lower)	R	Input capture	XXXXXXXX <sub>B</sub>
000061 <sub>H</sub>		Input capture data register ch0 (upper)	R		XXXXXXXX <sub>B</sub>
000062 <sub>H</sub>	IPCP1	Input capture data register ch1 (lower)	R		XXXXXXXX <sub>B</sub>
000063 <sub>H</sub>		Input capture data register ch1 (upper)	R		XXXXXXXX <sub>B</sub>
000064 <sub>H</sub>	IPCP2	Input capture data register ch2 (lower)	R		XXXXXXXX <sub>B</sub>
000065 <sub>H</sub>		Input capture data register ch2 (upper)	R		XXXXXXXX <sub>B</sub>
000066 <sub>H</sub>	IPCP3	Input capture data register ch3 (lower)	R		XXXXXXXX <sub>B</sub>
000067 <sub>H</sub>		Input capture data register ch3 (upper)	R		XXXXXXXX <sub>B</sub>
000068 <sub>H</sub>	ICS01	Input capture control register 01	R/W		0 0 0 0 0 0 0 <sub>B</sub>
000069 <sub>H</sub>	Access prohibited				
00006A <sub>H</sub>	ICS23	Input capture control register 23	R/W	Input capture	0 0 0 0 0 0 0 <sub>B</sub>
00006B <sub>H</sub> to 00006E <sub>H</sub>	Access prohibited				

(Continued)

# MB90560/565 Series

Address	Abbreviated Register Name	Register name	Read/Write	Resource Name	Initial Value	
00006FH	ROMM	ROM mirror function selection register	W	ROM mirror function selection module	XXXXXXXX <sub>1B</sub>	
000070H	OCCP0	Compare register ch0 (lower)	R/W	Output compare	XXXXXXXX <sub>B</sub>	
000071H		Compare register ch0 (upper)	R/W		XXXXXXXX <sub>B</sub>	
000072H	OCCP1	Compare register ch1 (lower)	R/W		XXXXXXXX <sub>B</sub>	
000073H		Compare register ch1 (upper)	R/W		XXXXXXXX <sub>B</sub>	
000074H	OCCP2	Compare register ch2 (lower)	R/W		XXXXXXXX <sub>B</sub>	
000075H		Compare register ch2 (upper)	R/W		XXXXXXXX <sub>B</sub>	
000076H	OCCP3	Compare register ch3 (lower)	R/W		XXXXXXXX <sub>B</sub>	
000077H		Compare register ch3 (upper)	R/W		XXXXXXXX <sub>B</sub>	
000078H	OCCP4	Compare register ch4 (lower)	R/W		XXXXXXXX <sub>B</sub>	
000079H		Compare register ch4 (upper)	R/W		XXXXXXXX <sub>B</sub>	
00007AH	OCCP5	Compare register ch5 (lower)	R/W		XXXXXXXX <sub>B</sub>	
00007BH		Compare register ch5 (upper)	R/W		XXXXXXXX <sub>B</sub>	
00007CH	OCS0	Compare control register ch0 (lower)	R/W		0000XX00 <sub>B</sub>	
00007DH	OCS1	Compare control register ch1 (upper)	R/W		XXX00000 <sub>B</sub>	
00007EH	OCS2	Compare control register ch2 (lower)	R/W		0000XX00 <sub>B</sub>	
00007FH	OCS3	Compare control register ch3 (upper)	R/W		XXX00000 <sub>B</sub>	
000080H	OCS4	Compare control register ch4 (lower)	R/W		0000XX00 <sub>B</sub>	
000081H	OCS5	Compare control register ch5 (upper)	R/W		XXX00000 <sub>B</sub>	
000082H	TMCSR0 : L	Timer control status register ch0 (lower)	R/W		16-bit reload timer	00000000 <sub>B</sub>
000083H	TMCSR0 : H	Timer control status register ch0 (upper)	R/W			XXXX0000 <sub>B</sub>
000084H	TMR0	16-bit timer register ch0 (lower)	R	XXXXXXXX <sub>B</sub>		
	TMRLR0	16-bit reload register ch0 (lower)	W	XXXXXXXX <sub>B</sub>		
000085H	TMR0	16-bit timer register ch0 (upper)	R	XXXXXXXX <sub>B</sub>		
	TMHR0	16-bit reload register ch0 (upper)	W	XXXXXXXX <sub>B</sub>		
000086H	TMCSR1 : L	Timer control status register ch1 (lower)	R/W	00000000 <sub>B</sub>		
000087H	TMCSR1 : H	Timer control status register ch1 (upper)	R/W	XXXX0000 <sub>B</sub>		
000088H	TMR1	16-bit timer register ch1 (lower)	R	XXXXXXXX <sub>B</sub>		
	TMRLR1	16-bit reload register ch1 (lower)	W	XXXXXXXX <sub>B</sub>		
000089H	TMR1	16-bit timer register ch1 (upper)	R	XXXXXXXX <sub>B</sub>		
	TMHR1	16-bit reload register ch1 (upper)	W	XXXXXXXX <sub>B</sub>		

(Continued)

# MB90560/565 Series

Address	Abbreviated Register Name	Register name	Read/Write	Resource Name	Initial Value
00008A <sub>H</sub> to 00008B <sub>H</sub>	Access prohibited				
00008C <sub>H</sub>	RDR0	Port 0 pull-up resistor setting register	R/W	Port 0	0 0 0 0 0 0 0 0 <sub>B</sub>
00008D <sub>H</sub>	RDR1	Port 1 pull-up resistor setting register	R/W	Port 1	0 0 0 0 0 0 0 0 <sub>B</sub>
00008E <sub>H</sub> to 00009D <sub>H</sub>	Access prohibited				
00009E <sub>H</sub>	PACSR	Program address detection control status register	R/W	Address match detection	0 0 0 0 0 0 0 0 <sub>B</sub>
00009F <sub>H</sub>	DIRR	Delayed interrupt request/clear register	R/W	Delayed interrupt	XXXXXXXX 0 <sub>B</sub>
0000A0 <sub>H</sub>	LPMCR	Low power consumption mode register	W, R/W	Low power consumption control circuit	0 0 0 1 1 0 0 0 <sub>B</sub>
0000A1 <sub>H</sub>	CKSCR	Clock selection register	R, R/W	Clock	1 1 1 1 1 1 0 0 <sub>B</sub>
0000A2 <sub>H</sub> to 0000A7 <sub>H</sub>	Access prohibited				
0000A8 <sub>H</sub>	WDTC	Watchdog control register	R/W	Watchdog timer	1 XXXX 1 1 1 <sub>B</sub>
0000A9 <sub>H</sub>	TBTC	Timebase timer control register	W, R/W	Timebase timer	1 XX 0 0 1 0 0 <sub>B</sub>
0000AA <sub>H</sub> to 0000AD <sub>H</sub>	Access prohibited				
0000AE <sub>H</sub>	FMCS	Flash memory control status register	R, W, R/W	Flash memory	0 0 0 0 0 0 0 0 <sub>B</sub>
0000AF <sub>H</sub>	Access prohibited				
0000B0 <sub>H</sub>	ICR00	Interrupt control register 00 (for writing)	W, R/W	Interrupts	XXXX 0 1 1 1 <sub>B</sub>
		Interrupt control register 00 (for reading)	R, R/W		XX 0 0 0 1 1 1 <sub>B</sub>
0000B1 <sub>H</sub>	ICR01	Interrupt control register 01 (for writing)	W, R/W		XXXX 0 1 1 1 <sub>B</sub>
		Interrupt control register 01 (for reading)	R, R/W		XX 0 0 0 1 1 1 <sub>B</sub>
0000B2 <sub>H</sub>	ICR02	Interrupt control register 02 (for writing)	W, R/W		XXXX 0 1 1 1 <sub>B</sub>
		Interrupt control register 02 (for reading)	R, R/W		XX 0 0 0 1 1 1 <sub>B</sub>
0000B3 <sub>H</sub>	ICR03	Interrupt control register 03 (for writing)	W, R/W		XXXX 0 1 1 1 <sub>B</sub>
		Interrupt control register 03 (for reading)	R, R/W		XX 0 0 0 1 1 1 <sub>B</sub>
0000B4 <sub>H</sub>	ICR04	Interrupt control register 04 (for writing)	W, R/W		XXXX 0 1 1 1 <sub>B</sub>
		Interrupt control register 04 (for reading)	R, R/W		XX 0 0 0 1 1 1 <sub>B</sub>
0000B5 <sub>H</sub>	ICR05	Interrupt control register 05 (for writing)	W, R/W		XXXX 0 1 1 1 <sub>B</sub>
		Interrupt control register 05 (for reading)	R, R/W		XX 0 0 0 1 1 1 <sub>B</sub>

(Continued)

# MB90560/565 Series

Address	Abbreviated Register Name	Register name	Read/Write	Resource Name	Initial Value
0000B6 <sub>H</sub>	ICR06	Interrupt control register 06 (for writing)	W, R/W	Interrupts	XXXX 0 1 1 1 <sub>B</sub>
		Interrupt control register 06 (for reading)	R, R/W		XX 0 0 0 1 1 1 <sub>B</sub>
0000B7 <sub>H</sub>	ICR07	Interrupt control register 07 (for writing)	W, R/W		XXXX 0 1 1 1 <sub>B</sub>
		Interrupt control register 07 (for reading)	R, R/W		XX 0 0 0 1 1 1 <sub>B</sub>
0000B8 <sub>H</sub>	ICR08	Interrupt control register 08 (for writing)	W, R/W		XXXX 0 1 1 1 <sub>B</sub>
		Interrupt control register 08 (for reading)	R, R/W		XX 0 0 0 1 1 1 <sub>B</sub>
0000B9 <sub>H</sub>	ICR09	Interrupt control register 09 (for writing)	W, R/W		XXXX 0 1 1 1 <sub>B</sub>
		Interrupt control register 09 (for reading)	R, R/W		XX 0 0 0 1 1 1 <sub>B</sub>
0000BA <sub>H</sub>	ICR10	Interrupt control register 10 (for writing)	W, R/W		XXXX 0 1 1 1 <sub>B</sub>
		Interrupt control register 10 (for reading)	R, R/W		XX 0 0 0 1 1 1 <sub>B</sub>
0000BB <sub>H</sub>	ICR11	Interrupt control register 11 (for writing)	W, R/W		XXXX 0 1 1 1 <sub>B</sub>
		Interrupt control register 11 (for reading)	R, R/W		XX 0 0 0 1 1 1 <sub>B</sub>
0000BC <sub>H</sub>	ICR12	Interrupt control register 12 (for writing)	W, R/W		XXXX 0 1 1 1 <sub>B</sub>
		Interrupt control register 12 (for reading)	R, R/W		XX 0 0 0 1 1 1 <sub>B</sub>
0000BD <sub>H</sub>	ICR13	Interrupt control register 13 (for writing)	W, R/W		XXXX 0 1 1 1 <sub>B</sub>
		Interrupt control register 13 (for reading)	R, R/W		XX 0 0 0 1 1 1 <sub>B</sub>
0000BE <sub>H</sub>	ICR14	Interrupt control register 14 (for writing)	W, R/W		XXXX 0 1 1 1 <sub>B</sub>
		Interrupt control register 14 (for reading)	R, R/W		XX 0 0 0 1 1 1 <sub>B</sub>
0000BF <sub>H</sub>	ICR15	Interrupt control register 15 (for writing)	W, R/W	XXXX 0 1 1 1 <sub>B</sub>	
		Interrupt control register 15 (for reading)	R, R/W	XX 0 0 0 1 1 1 <sub>B</sub>	
0000C0 <sub>H</sub> to 0000FF <sub>H</sub>	Unused area				
000100 <sub>H</sub> to # <sub>H</sub>	RAM area				
# <sub>H</sub> to 001FEF <sub>H</sub>	Reserved area				
001FF0 <sub>H</sub>	PADR0	Program address detection register ch0 (lower)	R/W	Address match detection	XXXXXXXX <sub>B</sub>
001FF1 <sub>H</sub>		Program address detection register ch0 (middle)	R/W		XXXXXXXX <sub>B</sub>
001FF2 <sub>H</sub>		Program address detection register ch0 (lower)	R/W		XXXXXXXX <sub>B</sub>

(Continued)

(Continued)

Address	Abbreviated Register Name	Register name	Read/Write	Resource Name	Initial Value
001FF3 <sub>H</sub>	PADR1	Program address detection register ch1 (lower)	R/W	Address match detection	XXXXXXXX <sub>B</sub>
001FF4 <sub>H</sub>		Program address detection register ch1 (middle)	R/W		XXXXXXXX <sub>B</sub>
001FF5 <sub>H</sub>		Program address detection register ch1 (lower)	R/W		XXXXXXXX <sub>B</sub>
001FF6 <sub>H</sub> to 001FFF <sub>H</sub>	Unused area				

- Read/write notation  
 R/W : Reading and writing permitted  
 R : Read-only  
 W : Write-only
- Initial value notation  
 0 : Initial value is "0".  
 1 : Initial value is "1".  
 X : Initial value is undefined.



○ : Supported

× : Not supported

◎ : Supported, includes EI<sup>2</sup>OS stop function

△ : Available if the interrupt that shares the same ICR is not used.

\* : If two or more interrupts with the same level occur simultaneously, the interrupt with the lower interrupt vector number has priority

# MB90560/565 Series

## ■ PERIPHERAL FUNCTIONS

### 1. I/O Ports

- The I/O ports can be used as general-purpose I/O ports (parallel I/O ports) . The MB90560/565 series have 7 ports (51 pins) . The ports share pins with the inputs and outputs of the peripheral functions.
- The port data registers (PDR) are used to output data to the I/O pins and read the data input from the I/O ports. Similarly, the port direction registers (DDR) set the I/O direction (input or output) for each individual port bit.
- The following table lists the I/O ports and the peripheral functions with which they share pins.

	Pin Name (Port)	Pin Name (Peripheral)	Peripheral Function that Shares Pin
Port 0	P00-P07	—	Not shared
Port 1	P10-P16	INT0-INT6	External interrupts
	P17	FRCK	Freerun timer external input
Port 2	P20-P23	TIN0, TO0, TIN1, TO1	16-bit reload timer 0 and 1
	P24-P27	IN0-IN3	Input capture 0 to 3
Port 3	P30-P35	RTO0-RTO5	Output compare
	P36, P37	SIN0, SOT0	UART0
Port 4	P40	SCK0	UART0
	P41-P46	PPG0-PPG5	8/16-bit PPG timer
Port 5	P50-P57	AN0-AN7	8/10-bit A/D converter
Port 6	P60-P62	SIN1, SOT1, SCK1	UART1
	P63	INT7	External interrupts
		DTTI	Waveform generator

Notes : • Pins P30 to P35 of port 3 can drive a maximum of  $I_{oL} = 12$  mA.

- Port 5 shares pins with the analog inputs. When using port 5 pins as a general-purpose ports, ensure that the corresponding analog input enable register (ADER) bits are set to "0b". ADER is initialized to "FFH" after a reset.

### • Block diagram for port 0 and 1 pins

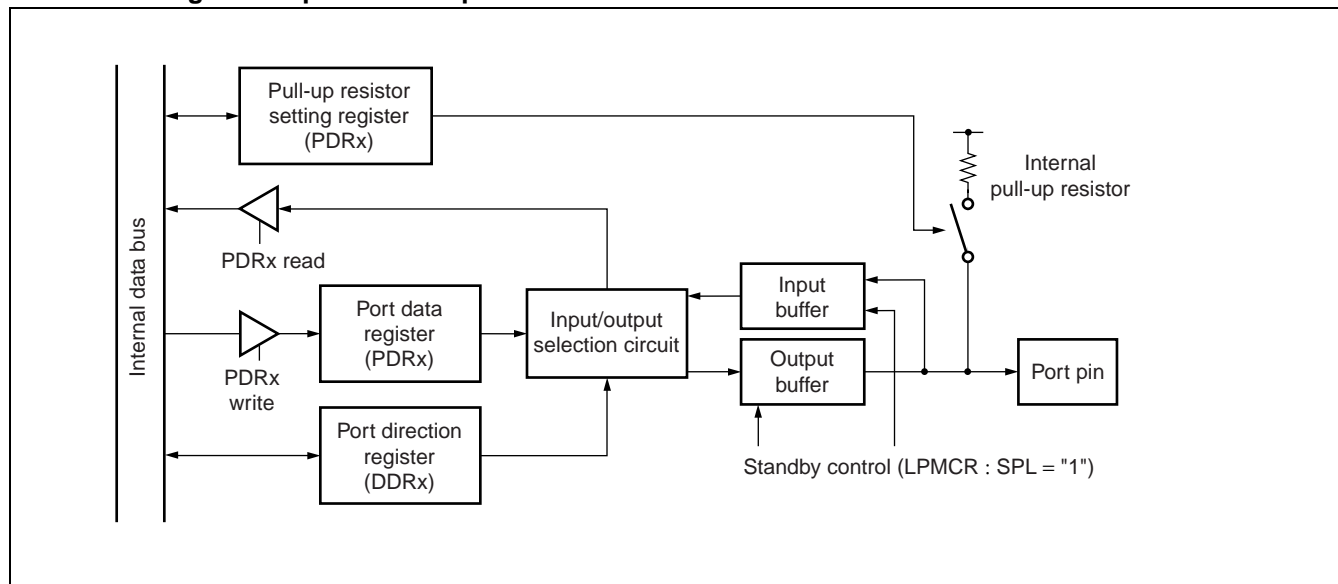

## • Block diagram for port 2, 3, 4, and 6 pins

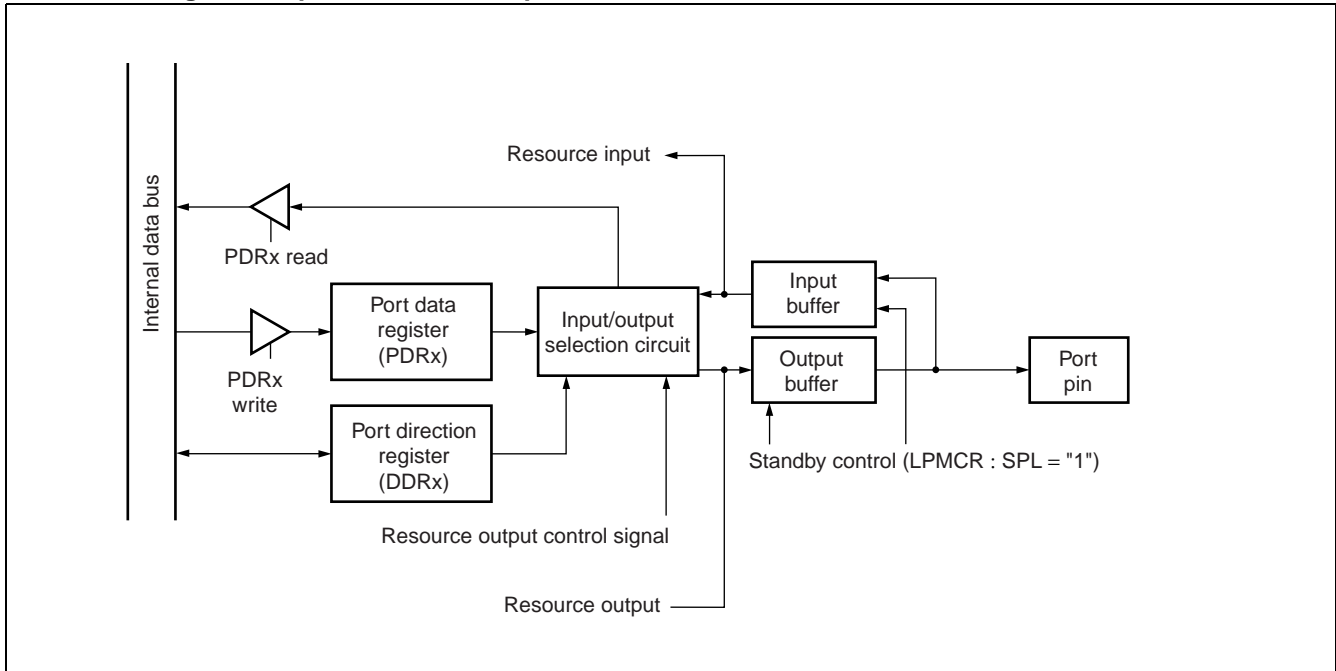

## • Block diagram for port 5 pins

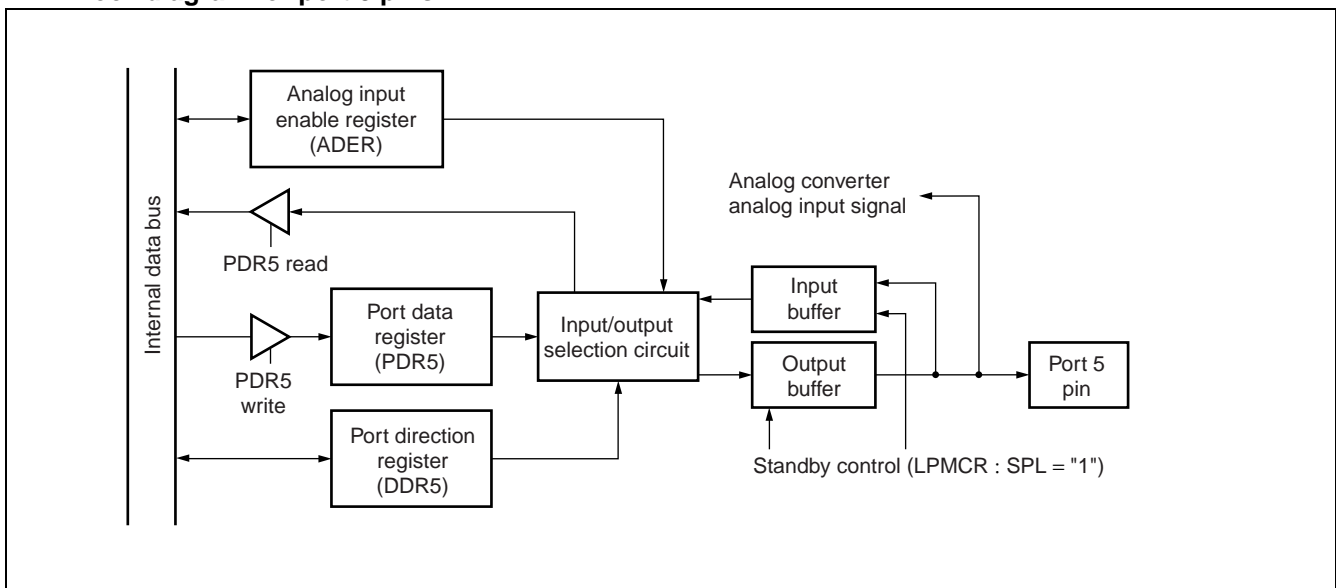

- Notes:
- When using as an input port, set the corresponding bit in the port 5 direction register (DDR5) to "0" and set the corresponding bit in the analog input enable register (ADER) to "0".
  - When using as an analog input pin, set the corresponding bit in the port 5 direction register (DDR5) to "0" and set the corresponding bit in the analog input enable register (ADER) to "1".

# MB90560/565 Series

## 2. Timebase Timer

- The timebase timer is an 18-bit freerun timer (timebase timer/counter) that counts up synchronized with the main clock (oscillation clock : HCLK divided into 2) .
- The timer can generate interrupt requests at a specified interval, with four different interval time settings available.
- The timer supplies the operating clock for peripheral functions including the oscillation stabilization delay timer and watchdog timer.

### • Timebase timer interval settings

Internal Count Clock Period	Interval Time
2/HCLK (0.5 μs)	2 <sup>12</sup> /HCLK (approx. 1.024 ms)
	2 <sup>14</sup> /HCLK (approx. 4.096 ms)
	2 <sup>16</sup> /HCLK (approx. 16.384 ms)
	2 <sup>19</sup> /HCLK (approx. 131.072 ms)

Notes : • HCLK : Oscillation clock frequency

- The values enclosed in ( ) indicate the times for a clock frequency of 4 MHz.

### • Period of clocks supplied from timebase timer

Peripheral Function	Clock Period
Oscillation stabilization delay for the main clock	2 <sup>10</sup> /HCLK (approx. 0.256 ms)
	2 <sup>13</sup> /HCLK (approx. 2.048 ms)
	2 <sup>15</sup> /HCLK (approx. 8.192 ms)
	2 <sup>17</sup> /HCLK (approx. 32.768 ms)
Watchdog timer	2 <sup>12</sup> /HCLK (approx. 1.024 ms)
	2 <sup>14</sup> /HCLK (approx. 4.096 ms)
	2 <sup>16</sup> /HCLK (approx. 16.384 ms)
	2 <sup>19</sup> /HCLK (approx. 131.072 ms)

Notes : • HCLK : Oscillation clock frequency

- The values enclosed in ( ) indicate the times for a clock frequency of 4 MHz.

• Block diagram

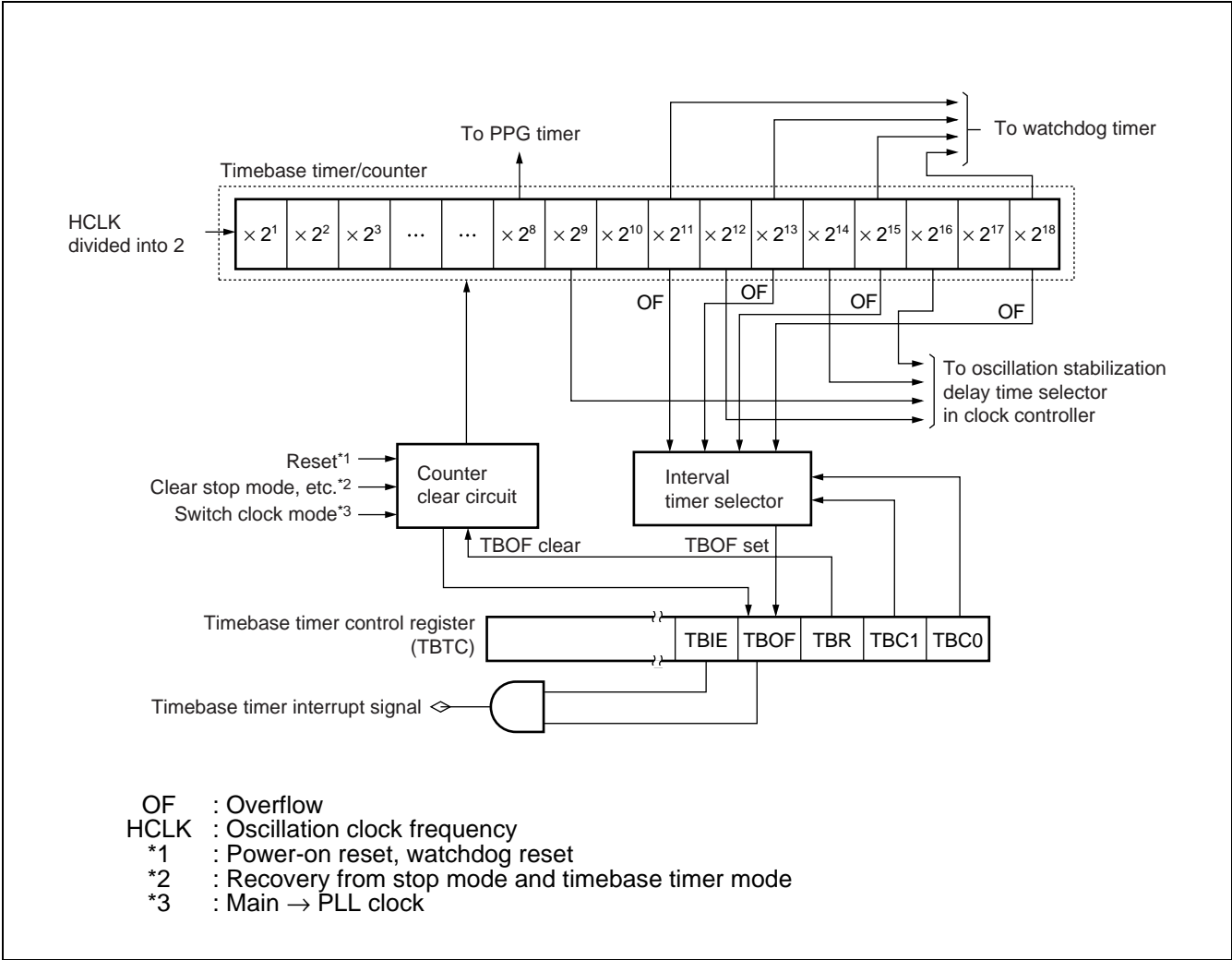

The actual interrupt request number for the timebase timer is :  
 Interrupt request number : #36 (24H)

### 3. Watchdog Timer

- The watchdog timer is a timer/counter used to detect faults such as program runaway.
- The watchdog timer is a 2-bit counter that counts the clock signal from the timebase timer or watch timer.
- Once started, the watchdog timer must be cleared before the 2-bit counter overflows. If an overflow occurs, the CPU is reset.

- **Interval time for the watchdog timer**

HCLK : Oscillation Clock (4 MHz)		
Min.	Max.	Clock Period
Approx. 3.58 ms	Approx. 4.61 ms	$2^{14} \pm 2^{11} / \text{HCLK}$
Approx. 14.33 ms	Approx. 18.30 ms	$2^{16} \pm 2^{13} / \text{HCLK}$
Approx. 57.23 ms	Approx. 73.73 ms	$2^{18} \pm 2^{15} / \text{HCLK}$
Approx. 458.75 ms	Approx. 589.82 ms	$2^{18} \pm 2^{15} / \text{HCLK}$

- Notes :
- The difference between the maximum and minimum watchdog timer interval times is due to the timing when the counter is cleared.
  - As the watchdog timer is a 2-bit counter that counts the carry-up signal from the timebase timer or watch timer, clearing the timebase timer (when operating on HCLK) or the watch timer (when operating on SCLK) lengthens the time until the watchdog timer reset is generated.

- **Watchdog timer count clock**

WTC : WDCS	HCLK : Oscillation clock PCLK : PLL clock
"0"	Prohibited setting
"1"	Count the timebase timer output.

- **Events that stop the watchdog timer**

- 1 : Stop due to a power-on reset
- 2 : Watchdog reset

- **Events that clear the watchdog timer**

- 1 : External reset input from the  $\overline{\text{RST}}$  pin.
- 2 : Writing "0" to the software reset bit.
- 3 : Writing "0" to the watchdog control bit (second and subsequent times) .
- 4 : Changing to sleep mode (clears the watchdog timer and temporarily halts the count) .
- 5 : Changing to timebase timer mode (clears the watchdog timer and temporarily halts the count) .
- 6 : Changing to stop mode (clears the watchdog timer and temporarily halts the count) .

• Block diagram

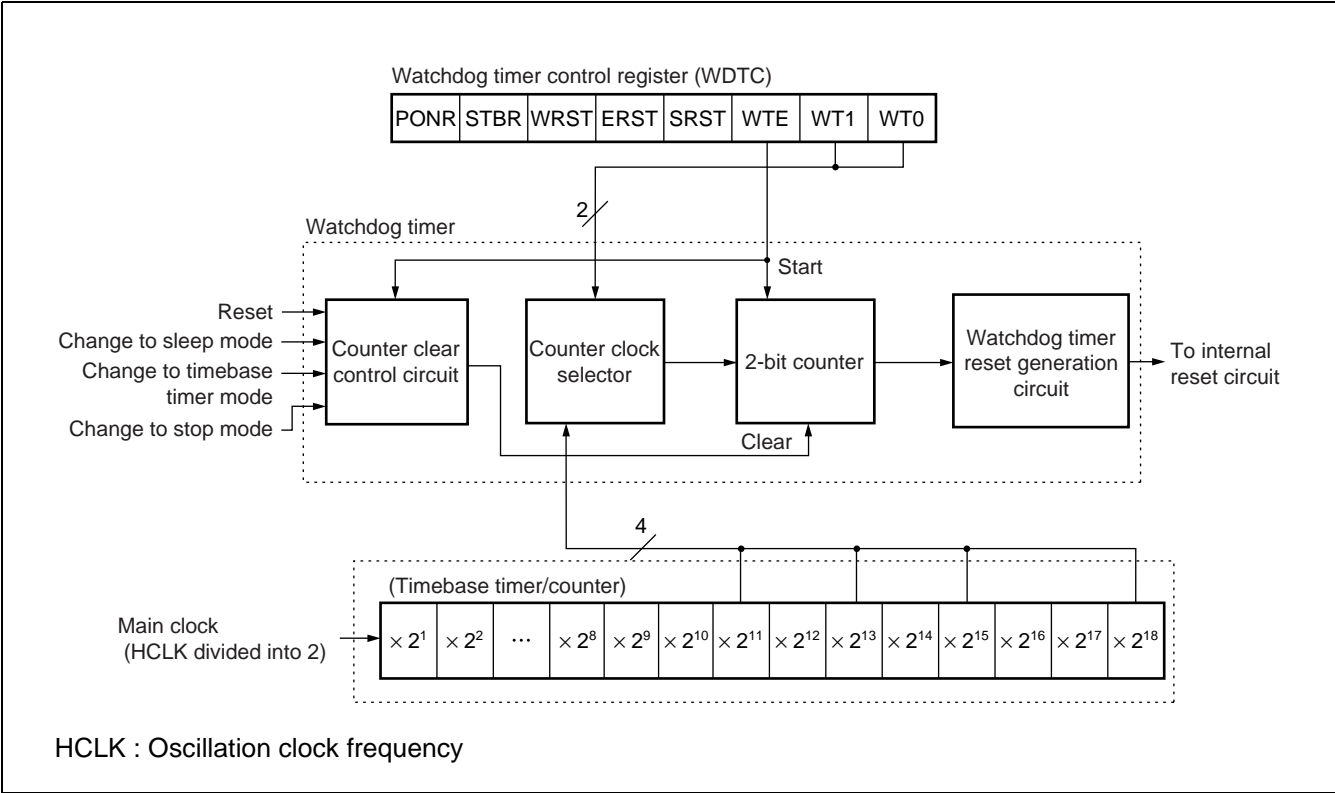

## 4. 16-Bit Reload Timers 0 and 1 (With Event Count Function)

- The 16-bit reload timers have the following functions.
- The count clock can be selected from three internal clocks or the external event clock.
- An interrupt to the CPU can be generated when an underflow occurs on 16-bit reload timer 0 or 1. This interrupt allows the timers to be used as interval timers.
- Two different operation modes can be selected when an underflow occurs on 16-bit reload timer 0 or 1: one-shot mode in which timer operation halts when an underflow occurs or reload mode in which the value in the reload register is loaded into the timer and counting continues.
- Extended intelligent I/O service (EI<sup>2</sup>OS) is supported.
- The MB90560/565 series contains two 16-bit reload timer channels.

### • 16-bit reload timer operation modes

Count Clock	Start Trigger	Operation When an Underflow Occurs
Internal clock	Software trigger	One-shot mode
		Reload mode
	External trigger	One-shot mode
		Reload mode
Event count mode (external clock mode)	Software trigger	One-shot mode
		Reload mode

### • Interval times for the 16-bit reload timers

Count Clock	Count Clock Period	Example of Interval Times
Internal clock	$2^1/\phi$ (0.125 $\mu$ s)	0.125 $\mu$ s to 8.192 ms
	$2^3/\phi$ (0.5 $\mu$ s)	0.5 $\mu$ s to 32.768 ms
	$2^5/\phi$ (2.0 $\mu$ s)	2.0 $\mu$ s to 131.1 ms
Event count mode	$2^3/\phi$ or longer	0.5 $\mu$ s or longer

Note : The values enclosed in ( ) and the example of interval times is for a machine clock frequency of 16 MHz.  
 $\phi$  is the machine clock frequency value for the calculation.

Remarks : 16-bit reload timer 0 can be used to generate the baud rate for UART0.  
 16-bit reload timer 1 can be used to generate the baud rate for UART1 and activation trigger for the A/D converter.

• Block diagram

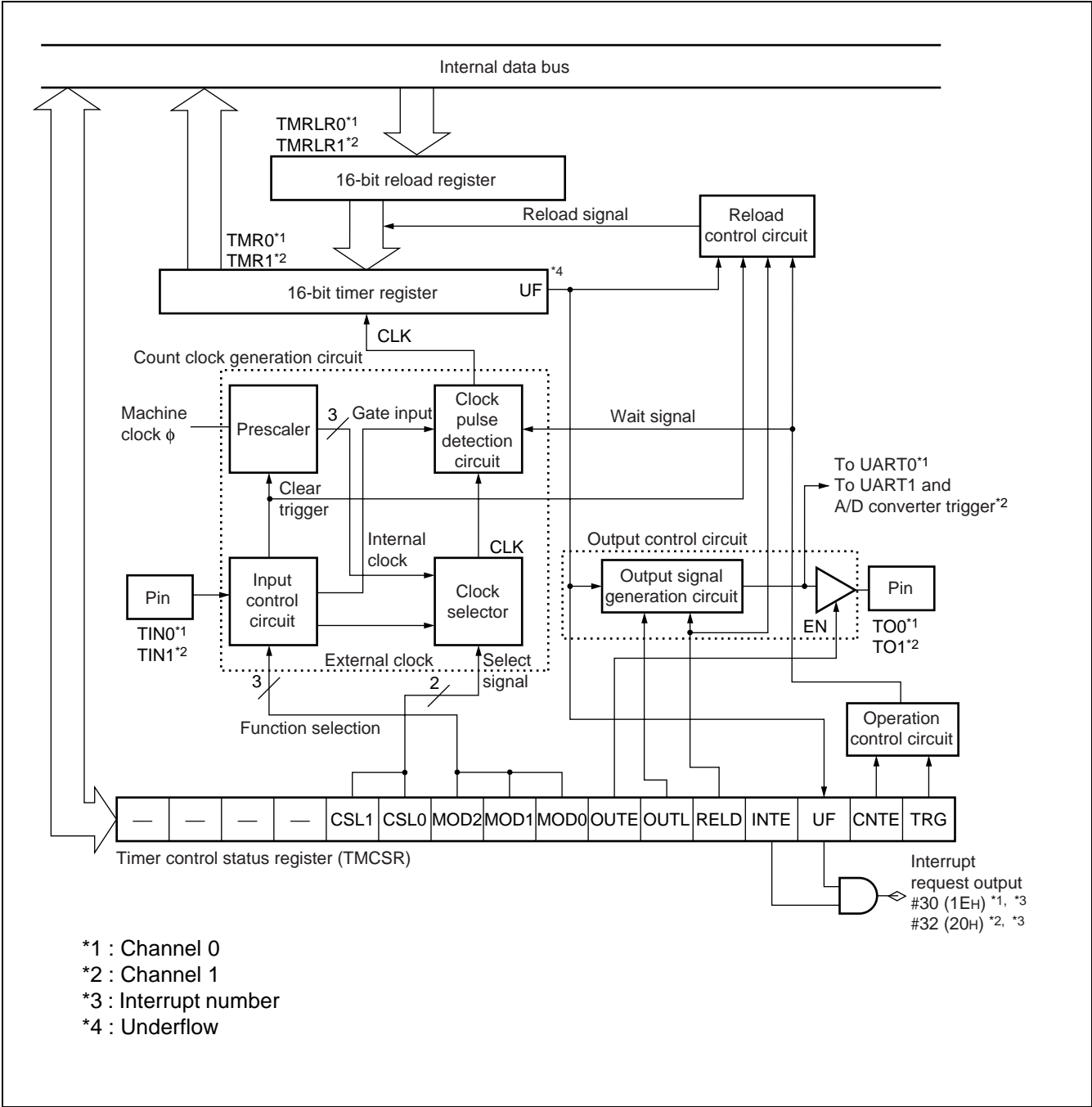

## 5. Multi-Function Timer

- Based on the 16-bit freerun timer, the multi-function timer can be used to generate 12 independent waveform outputs and to measure input pulse widths and external clock periods.

- Structure of multi-function timer**

16-bit freerun timer	16-bit output compare	16-bit input capture	8/16-bit PPG timer	Waveform generator
1 ch	6 ch	4 ch	8 bit × 6 ch 16 bit × 3 ch	8-bit timer × 3 ch

- 16-bit freerun timer (1 channel)**

The 16-bit freerun timer consists of a 16-bit up-counter (timer data register (TCDT) ), compare clear register (CPCLR) , timer control status register (TCCS) , and prescaler.

The count output value from the 16-bit freerun timer provides the base time for the input capture and output compare functions.

- The count clock can be selected from the following eight clocks :  
1/φ, 2/φ, 4/φ, 8/φ, 16/φ, 32/φ, 64/φ, 128/φ  
φ : Machine clock frequency
- An interrupt can be generated when the 16-bit freerun timer overflows or when the 16-bit freerun timer count is cleared to "0000<sub>H</sub>" due to a match occurring between the value in the compare clear register (CPCLR) and the count in the 16-bit freerun timer (TCCS : ICRE = "1", MODE = "1") .
- The 16-bit freerun timer is cleared to "0000<sub>H</sub>" when a reset occurs, on setting the timer clear bit (SCLR) in the timer control status register (TCCS) , when a compare match occurs between the 16-bit freerun timer count and the value in the compare clear register (CPCLR) (TCCS : MODE = "1") , or by writing "0000<sub>H</sub>" to the timer data register (TCDT) .

- Output compare (6 channels)**

The output compare unit consists of compare registers (OCCP0 to OCCP5) , compare control registers (OCS0 to OCS5) , and compare output latches.

When a match occurs between a compare register (OCCP0 to OCCP5) value and the count from the 16-bit freerun timer, the output compare can invert the level of the corresponding output compare pin and generate an interrupt.

- The compare registers (OCCP0 to OCCP5) operate independently for each channel. Each of the compare registers (OCCP0 to OCCP5) has a corresponding output pin and an interrupt request flag in the channel's compare control register (lower) (OCS0, OCS2, OCS4) .
- Two channels of the compare registers (OCCP0 to OCCP5) can be used to invert the output pins.
- An interrupt can be output when a match occurs between a compare register (OCCP0 to OCCP5) and the count from the 16-bit freerun timer (OCS0, OCS2, OCS4 : IOP0 = "1", IOP1 = "1") . (OCS0, OCS2, OCS4 : IOE0 = "1", IOE1 = "1")
- The initial output levels for the output compare pins can be set.

- Input capture (4 channels)**

The input capture consists of external input pins (IN0 to IN3) , corresponding input capture data registers (IPCP0 to IPCP3) , and input capture control status registers (ICS01, ICS23) .

The input capture can transfer the count value from the 16-bit freerun timer to the input capture data register (IPCP0 to IPCP3) and output an interrupt on detecting an active edge on the signal input from the external input pin.

- Each channel of the input capture operates independently.
- The active edge (rising edge, falling edge, or either edge) on the external signal can be specified.

- An interrupt can be generated when an active edge is detected on the external signal (ICS01, ICS23 : ICE0 = "1", ICE1 = "1", ICE2 = "1", ICE3 = "1") .

- **8/16-bit PPG timer (8-bit : 6 channels, 16-bit : 3 channels)**

The 8/16-bit PPG timer consists of an 8-bit down counter (PCNT) , PPG control registers (PPGC0 to PPGC5) , PPG clock control registers (PCS01, PCS23, PCS45) , and PPG reload registers (PRL0 to PRL5, PRLH0 to PRLH5) .

When used as an 8/16-bit reload timer, the PPG operates as an event timer. The PPG can also be used to output pulses with specified frequency and duty ratio.

- 8-bit PPG mode

Each channel operates as an independent 8-bit PPG.

- 8-bit prescaler + 8-bit PPG mode

ch0 (ch2, ch4) operates as an 8-bit prescaler and ch1 (ch3, ch5) operates as a variable frequency PPG by counting up on the borrow output from ch0 (ch2, ch4) .

- 16-bit PPG mode

ch0 (ch2, ch4) and ch1 (ch3, ch5) operate together as a 16-bit PPG.

- PPG operation

Outputs pulses with the specified frequency and duty ratio (ratio of "H" level period and "L" level period), and can also be used as a D/A converter when combined with an external circuit.

- **Waveform generator**

The waveform generator consists of an 8-bit timer, 8-bit timer control registers (DTCR0 to DTCR2) , 8-bit reload registers (TMRR0 to TMRR2) , and waveform control register (SIGCR) .

The waveform generator can generate a DC chopper output or non-overlapping three-phase waveform output for inverter control using the realtime outputs (RT0 to RT5) and 8/16-bit PPG timer.

- A non-overlapping waveform can be generated by using the 8-bit timer as a deadtime timer and adding a non-overlap time delay to the PPG timer pulse output. (Deadtime timer function)
- A non-overlapping waveform can be generated by using the 8-bit timer as a deadtime timer and adding a non-overlap time delay to the realtime outputs (RT1, RT3, RT5) . (Deadtime timer function)
- A GATE signal can be generated when a match occurs between the count from the 16-bit freerun timer and compare register in the output compare (OCCP0 to OCCP5) (rising edge on realtime output (RT) ) to control the PPG timer operation. (GATE function)
- Can control the RTO0 to RTO5 pin outputs using the DTTI pin input.

By making the DTTI pin input clockless, the pins can be controlled externally even when the oscillation clock is halted. (The level for each pin can be set by the program.) However, the I/O ports (P30 to P35) must have been set beforehand as outputs and the output values set in the port 3 data register (PDR3) .

# MB90560/565 Series

- Block diagram
- 16-bit freerun timer, input capture, and output compare

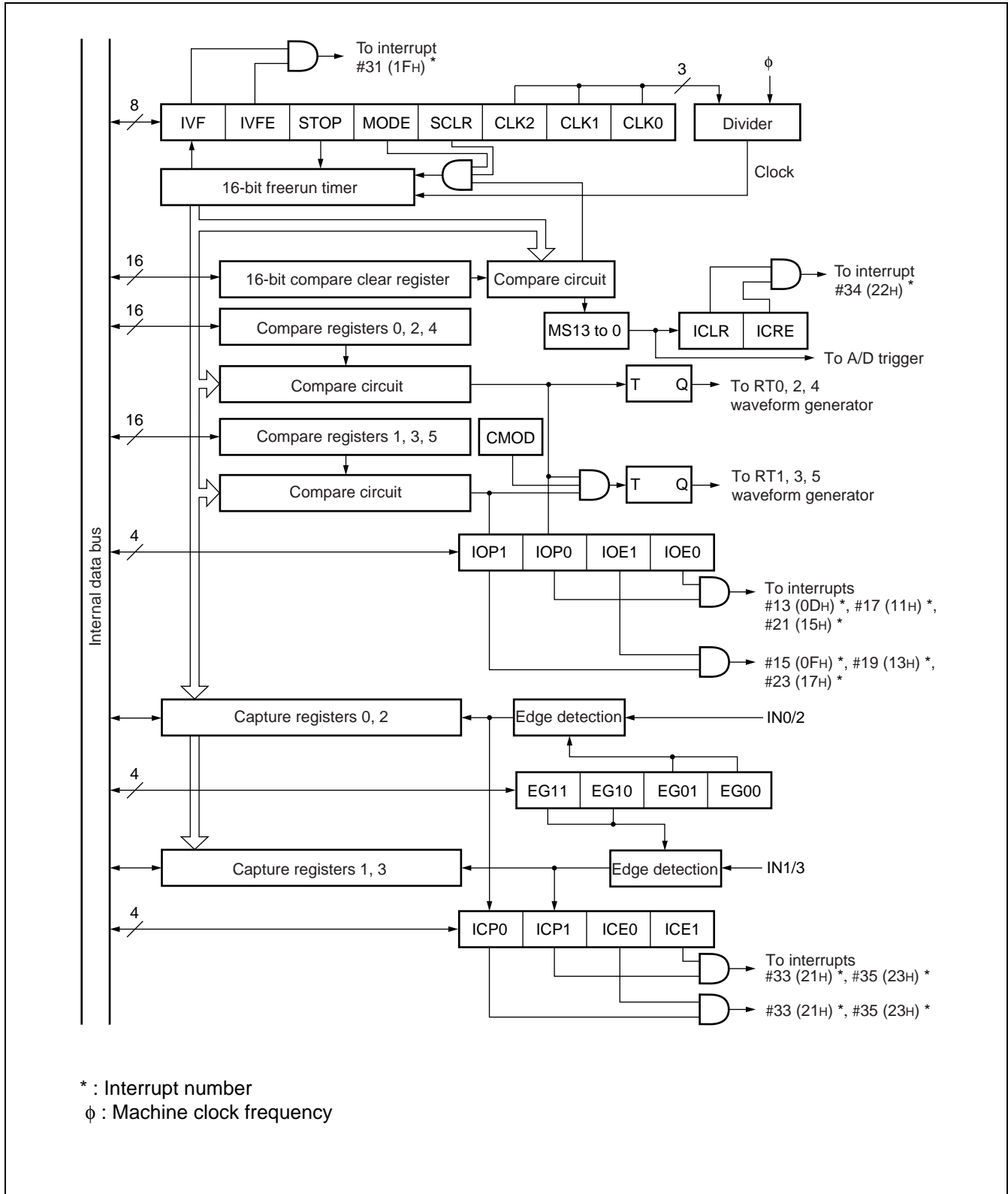

• Block diagram of 8/16-bit PPG timer

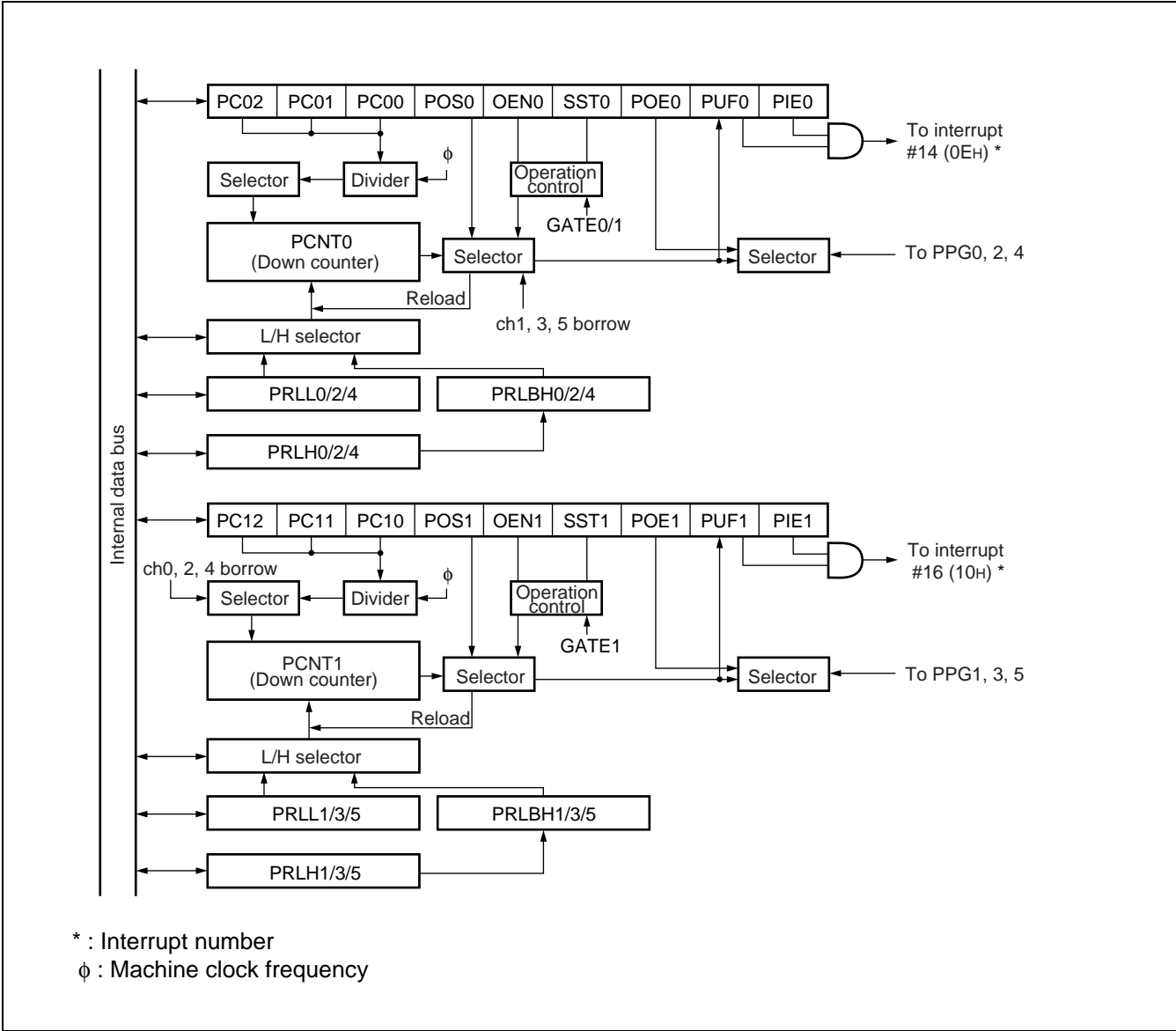

# MB90560/565 Series

## • Block diagram of waveform generator

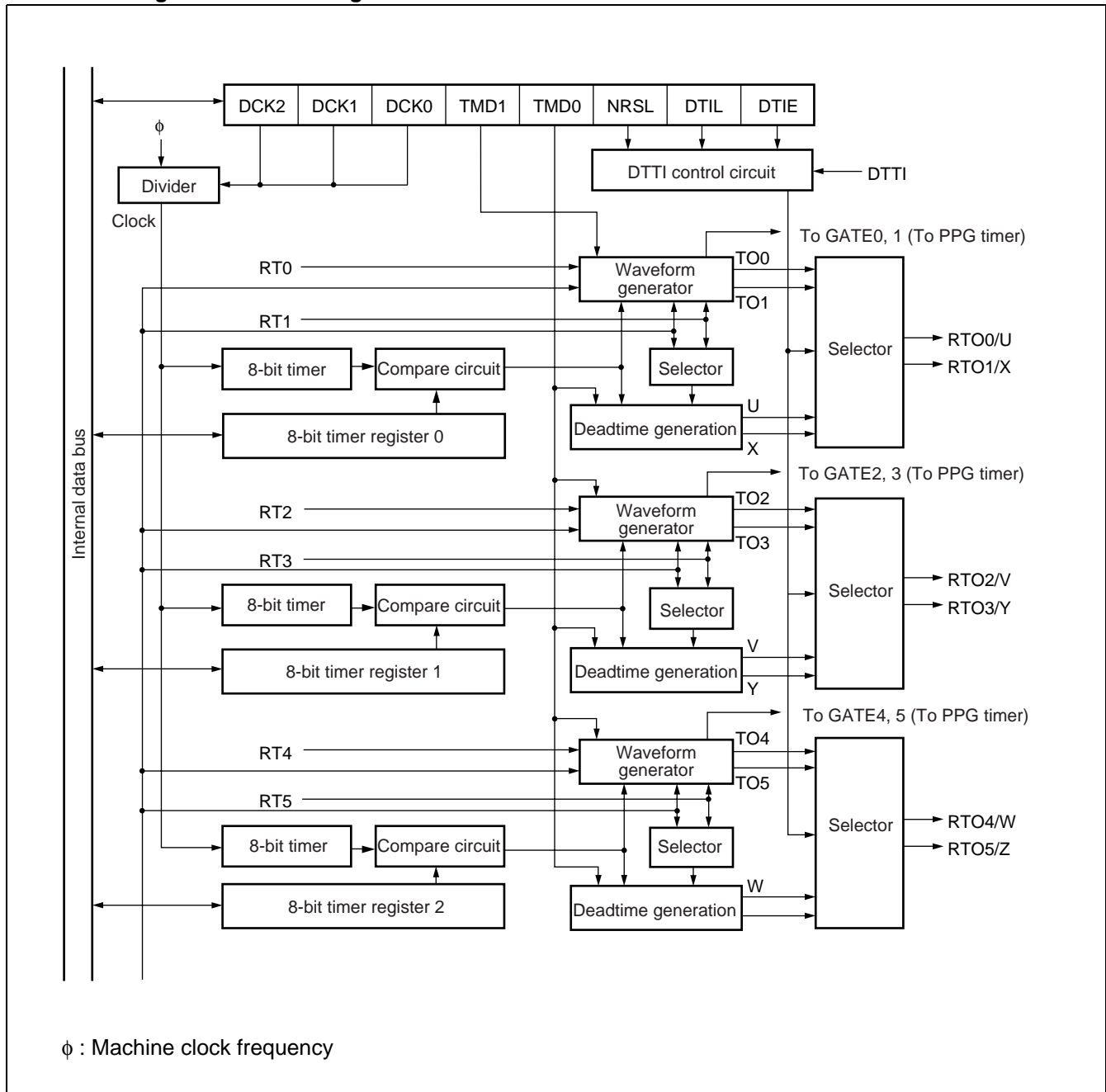

## 6. UART

### (1) Overview

- The UART is a general-purpose serial communications interface for performing synchronous or asynchronous (start-stop synchronization) communications with external devices.
- The interface provides both a bi-directional communication function (normal mode) and a master-slave communication function (multi-processor mode) .
- The UART can generate interrupt requests at receive complete, receive error detected, and transmit complete timings. Also the UART supports EI<sup>2</sup>OS.

### • UART functions

The UART is a general-purpose serial communications interface for sending serial data to and from other CPUs and peripheral devices.

	Function
Data buffer	Full-duplex double-buffered
Transmission modes	<ul style="list-style-type: none"> <li>• Clock synchronous (no start and stop bits)</li> <li>• Clock asynchronous (start-stop synchronization)</li> </ul>
Baud rate	<ul style="list-style-type: none"> <li>• Max. 2 MHz (for a 16 MHz machine clock)</li> <li>• Baud rate generated by dedicated baud rate generator</li> <li>• Baud rate generated by external clock (clock input from SCK0 and SCK1 pins)</li> <li>• Baud rate generated by internal clock (clock supplied from 16-bit reload timer)</li> <li>• Eight different baud rate settings are available.</li> </ul>
Number of data bits	<ul style="list-style-type: none"> <li>• 7 bits (asynchronous normal mode only)</li> <li>• 8 bits</li> </ul>
Signal format	Non return to zero (NRZ) format
Receive error detection	<ul style="list-style-type: none"> <li>• Framing errors</li> <li>• Overrun errors</li> <li>• Parity errors (not available in multi-processor mode)</li> </ul>
Interrupt requests	<ul style="list-style-type: none"> <li>• Receive interrupt (Receive complete or receive error detected)</li> <li>• Transmit interrupt (Transmission complete)</li> <li>• Both transmit and receive support the extended intelligent I/O service (EI<sup>2</sup>OS) .</li> </ul>
Master/slave communication function (multi-processor mode)	Used for 1 (master) to n (slave) communications. (Can only be used as master)

Note : The UART does not add the start and stop bits in clock synchronous mode. In this case, only data is transmitted.

# MB90560/565 Series

## • UART operation modes

Operation Mode		No. of Data Bits		Synchronization	No. of Stop Bits
		No Parity	With Parity		
0	Normal mode	7 or 8 bits		Asynchronous	1 or 2 bits*2
1	Multi-processor mode	8 + 1*1	—	Asynchronous	
2	Clock synchronous mode	8	—	Synchronous	None

— : Not available

\*1 : The “+1” represents the address/data (A/D) bit used for communication control.

\*2 : Only 1 stop bit supported for receiving.

## • UART interrupts and EI<sup>2</sup>OS

Interrupt	Interrupt No.	Interrupt Control Register		Vector Table Address			EI <sup>2</sup> OS
		Register Name	Address	Lower	Upper	Bank	
UART1 receive interrupt	#37 (25 <sub>H</sub> )	ICR13	0000BD <sub>H</sub>	FFFF68 <sub>H</sub>	FFFF69 <sub>H</sub>	FFFF6A <sub>H</sub>	◎
UART1 send interrupt	#38 (26 <sub>H</sub> )	ICR13	0000BD <sub>H</sub>	FFFF64 <sub>H</sub>	FFFF65 <sub>H</sub>	FFFF66 <sub>H</sub>	△
UART0 receive interrupt	#39 (27 <sub>H</sub> )	ICR14	0000BE <sub>H</sub>	FFFF60 <sub>H</sub>	FFFF61 <sub>H</sub>	FFFF62 <sub>H</sub>	◎
UART0 send interrupt	#40 (28 <sub>H</sub> )	ICR14	0000BE <sub>H</sub>	FFFF5C <sub>H</sub>	FFFF5D <sub>H</sub>	FFFF5E <sub>H</sub>	△

◎ : The UART has a function to halt EI<sup>2</sup>OS if a receive error is detected.

△ : Available when the interrupt shared with ICR13 or ICR14 is not used.

## (2) UART structure

The UART consists of the following 11 blocks:

- Clock selector
- Receive control circuit
- Transmission control circuit
- Receive status evaluation circuit
- Receive shift register
- Transmission shift register
- Mode registers (SMR0, SMR1)
- Control registers (SCR0, SCR1)
- Status registers (SSR0, SSR1)
- Input data registers (SIDR0, SIDR1)
- Output data registers (SODR0, SODR1)

• **Block diagram**

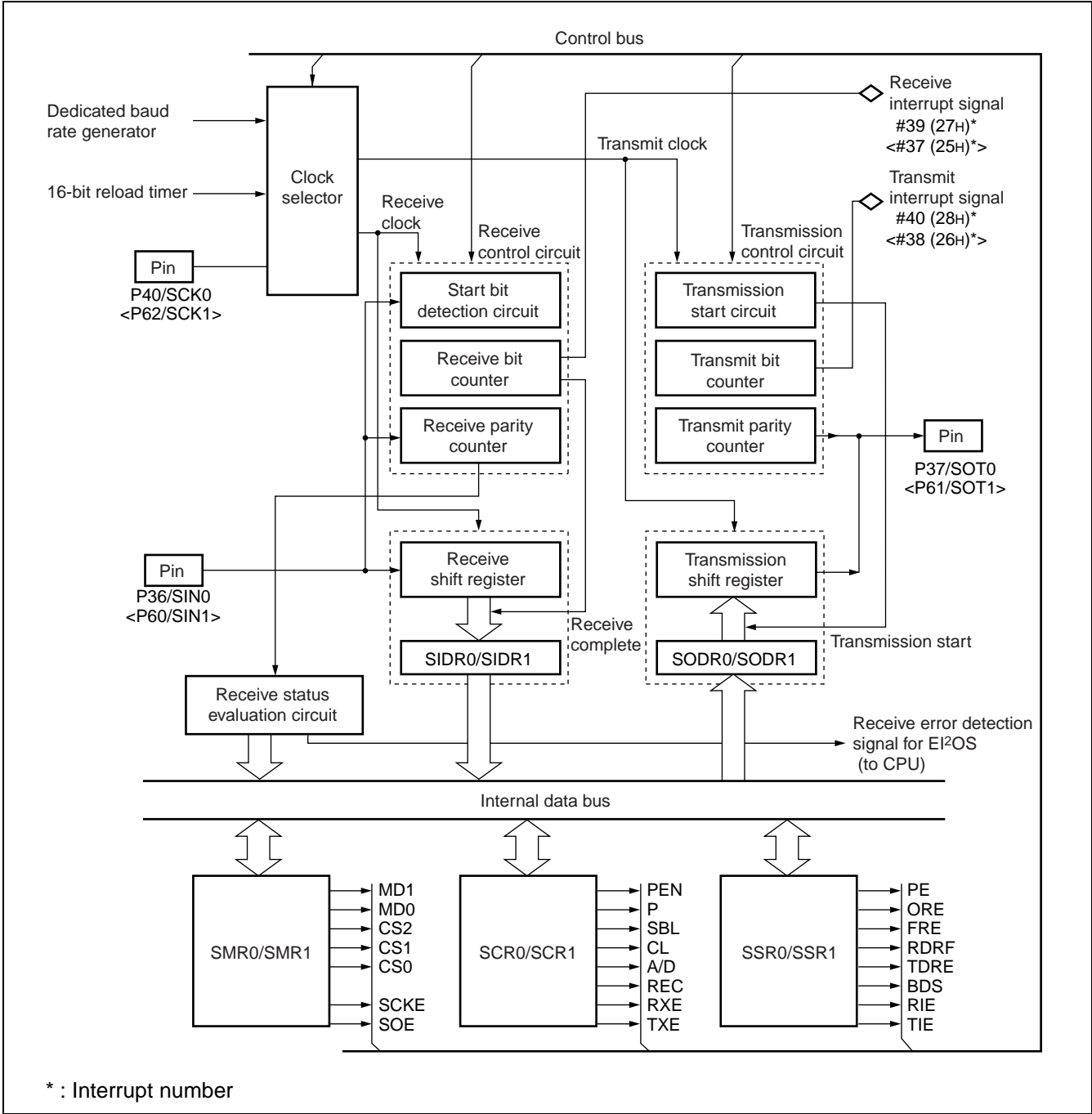

# MB90560/565 Series

- **Clock selector**

Selects the send/receive clock from either the dedicated baud rate generator, external input clock (clock input to SCK0 or SCK1 pin) , or internal clock (clock supplied by 16-bit reload timer) .

- **Receive control circuit**

The receive control circuit consists of a receive bit counter, start bit detection circuit, and receive parity counter. The receive bit counter counts the received data bits and outputs a receive interrupt request when the required number of data bits have been received. The start bit detection circuit detects the start bit on the serial input signal. On detecting a start bit, the receive data is shifted to the input data register (SIDR0 or SIDR1) in accordance with the specified transfer speed. The receive parity counter calculates the parity of the received data if parity is selected.

- **Transmission control circuit**

The transmission control circuit consists of a transmission bit counter, transmission start circuit, and transmission parity counter. The transmission bit counter counts the transmitted data bits and outputs a transmit interrupt request when the required number of data bits have been sent. The transmission start circuit starts transmission when data is written to the output data register (SODR0 or SODR1) . The transmission parity counter generates the parity bit for the transmitted data when parity is selected.

- **Receive shift register**

The receive shift register captures the data input from the SIN0 or SIN1 pin by shifting one bit at a time then transfers the received data to the input data register (SIDR0 or SIDR1) when reception completes.

- **Transmission shift register**

The transmission data is transferred from the output data register (SODR0 or SODR1) to the transmission shift register and output from the SOT0 or SOT1 pin by shifting one bit at a time.

- **Mode register (SMR0, SMR1)**

Set the operation mode, baud rate clock and serial clock input/output control, and enables output for the serial data pin.

- **Control register (SCR0, SCR1)**

Specifies whether to use parity, the type of parity, number of stop bits and data bits and the frame data format for operation mode 1, to clear the receive error flag bit, and to enable or disable send and receive operation.

- **Status register (SSR0, SSR1)**

Stores the send/receive and error status information, set the serial data transfer direction, and enables or disables the send and receive interrupt requests.

- **Input data register (SIDR0, SIDR1)**

Stores the received data.

- **Output data register (SODR0, SODR1)**

Set the transmission data. The data set in the output data register is converted to serial format and output.

## 7. DTP/External Interrupt Circuit

### (1) Overview of the DTP/external interrupt circuit

The DTP (Data Transfer Peripheral) /external interrupt circuit detects interrupt requests input to the external interrupt input pins (INT7 to INT0) and outputs interrupt requests.

- **DTP/external interrupt circuit functions**

The DTP/external interrupt function detects edge or level signals input to the external interrupt input pins (INT7 to INT0) and outputs interrupt requests.

The interrupt request is received by the CPU and, if the extended intelligent I/O service (EI<sup>2</sup>OS) is enabled, EI<sup>2</sup>OS performs automatic data transfer (DTP function) then passes control to the interrupt handler routine on completion. If EI<sup>2</sup>OS is disabled, control passes directly to the interrupt handler routine without performing automatic data transfer (DTP function) .

- **Overview of the DTP/external interrupt circuit**

	External Interrupt	DTP Function
Input pins	8 channels (P10/INT0 to P16/INT6, P63/INT7)	
Interrupt conditions	The level or edge to detect can be set independently for each pin in the detection level setup register (ELVR) .	
	"L" level, "H" level, rising edge, or falling edge input	
Interrupt number	#25 (19 <sub>H</sub> ) to #28 (1C <sub>H</sub> )	
Interrupt control	Interrupts can be enabled or disabled in the DTP/external interrupt enable register (ENIR) .	
Interrupt flag	The DTP/external interrupt request register (ENRR) stores interrupt requests.	
Processing selection	Set EI <sup>2</sup> OS to disabled (ICR : ISE = 0)	Set EI <sup>2</sup> OS to enabled (ICR : ISE = 1)
Operation	Jumps to interrupt handler routine	Jumps to interrupt handler routine after automatic data transfer by EI <sup>2</sup> OS completes.

ICR : Interrupt control register

- **DTP/external interrupt circuit interrupts and EI<sup>2</sup>OS**

Channel	Interrupt No.	Interrupt Control Register		Vector Table Address			EI <sup>2</sup> OS
		Register Name	Address	Lower	Upper	Bank	
INT0/INT1	#25 (19 <sub>H</sub> )	ICR07	0000B7 <sub>H</sub>	FFFF98 <sub>H</sub>	FFFF99 <sub>H</sub>	FFFF9A <sub>H</sub>	△
INT2/INT3	#26 (1A <sub>H</sub> )			FFFF94 <sub>H</sub>	FFFF95 <sub>H</sub>	FFFF96 <sub>H</sub>	
INT4/INT5	#27 (1B <sub>H</sub> )	ICR08	0000B8 <sub>H</sub>	FFFF90 <sub>H</sub>	FFFF91 <sub>H</sub>	FFFF92 <sub>H</sub>	
INT6/INT7	#28 (1C <sub>H</sub> )			FFFF8C <sub>H</sub>	FFFF8D <sub>H</sub>	FFFF8E <sub>H</sub>	

△ : Available when the interrupt shared with ICR07 or ICR08 is not used.

# MB90560/565 Series

## (2) Structure of the DTP/external interrupt circuit

The DTP/external interrupt circuit consists of the following four blocks :

- DTP/interrupt detection circuit
- DTP/interrupt request register (EIRR)
- DTP/interrupt enable register (ENIR)
- Request level setting register (ELVR)

### • Block diagram

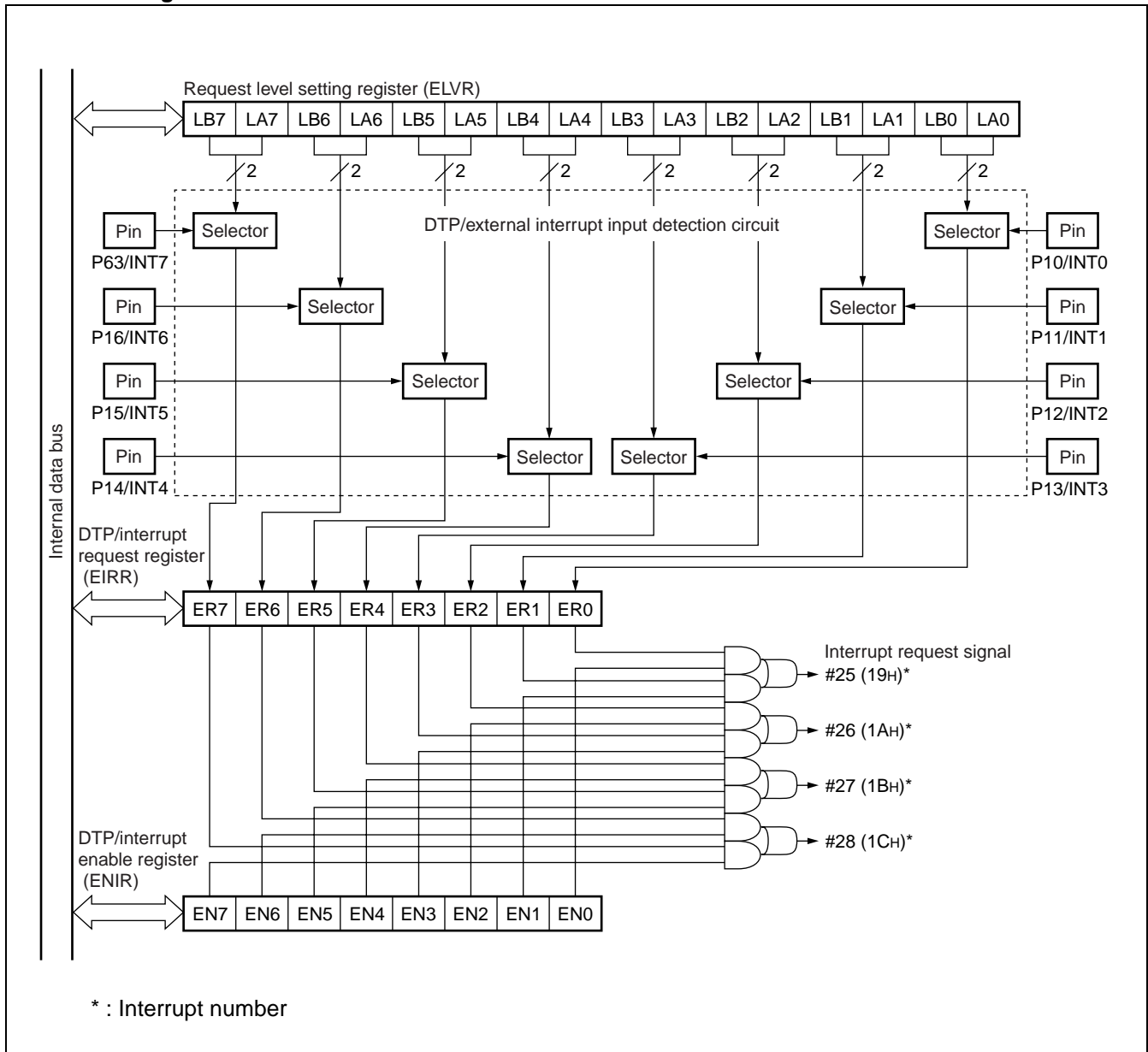

**8. Delayed Interrupt Generation Module**

- The delayed interrupt generation module is used to generate the task switching interrupt. Generation of this hardware interrupt can be specified by software.

• **Delayed interrupt generation module functions**

	Function and Control
Interrupt trigger	<ul style="list-style-type: none"> <li>• Writing "1" to bit R0 of the delayed interrupt request generation/clear register (DIRR : R0 = 1) generates an interrupt request.</li> <li>• Writing "0" to bit R0 of the delayed interrupt request generation/clear register (DIRR : R0 = 1) clears the interrupt request.</li> </ul>
Interrupt control	<ul style="list-style-type: none"> <li>• No enable/disable register is provided for this interrupt.</li> </ul>
Interrupt flag	<ul style="list-style-type: none"> <li>• Set in bit R0 of the delayed interrupt request generation/clear register (DIRR : R0) .</li> </ul>
EI <sup>2</sup> OS support	<ul style="list-style-type: none"> <li>• Not supported by the extended intelligent I/O service (EI<sup>2</sup>OS) .</li> </ul>

• **Block diagram**

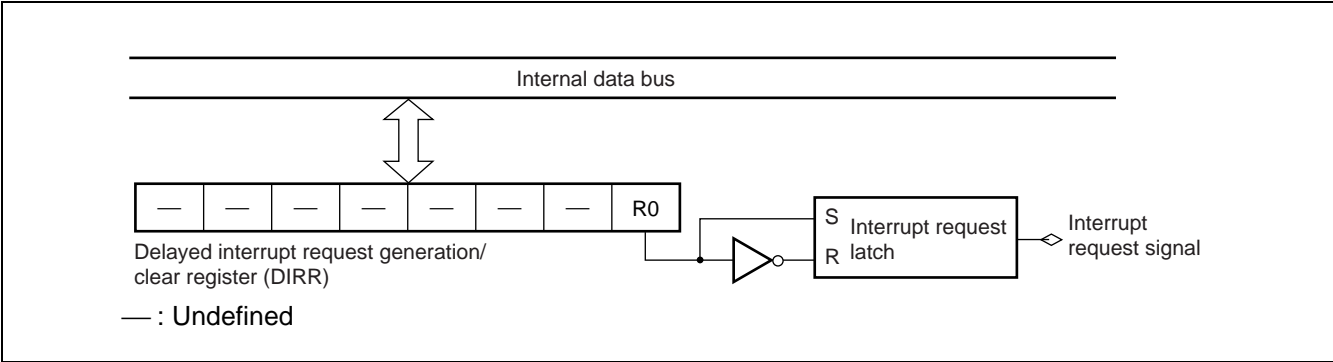

# MB90560/565 Series

## 9. 8/10-Bit A/D Converter

- **Overview of the 8/10-bit A/D converter**

- The 8/10-bit A/D converter uses RC successive approximation to convert analog input voltages to an 8-bit or 10-bit digital value.
- The input signals can be selected from the eight analog input pin channels.

- **8/10-bit A/D converter functions**

A/D conversion time	The minimum conversion time is 6.13 $\mu$ s (for a 16 MHz machine clock, including sampling time) . The minimum sampling time is 2.0 $\mu$ s (for a 16 MHz machine clock)
Conversion method	RC successive approximation with sample & hold circuit
Resolution	8-bit or 10-bit, selectable
Analog input pins	Eight analog input pin channels are available. The input pin can be selected by the program.
Interrupts	An interrupt request can be generated and EI <sup>2</sup> OS invoked when A/D conversion completes. The conversion data protection function operates when A/D conversion is performed with the interrupt enabled.
A/D conversion start trigger	The conversion start trigger can be set from the following options : software, output of 16-bit reload timer 1 (rising edge) , or zero detection edge from 16-bit freerun timer.
EI <sup>2</sup> OS support	Supported by the extended intelligent I/O service (EI <sup>2</sup> OS) .

- **8/10-bit A/D converter conversion modes**

Conversion Mode	Single Conversion Mode Operation	Scan Conversion Mode Operation
Single-shot conversion mode 1 Single-shot conversion mode 2	Performs one conversion for the specified channel (1 channel) then halts.	Sequentially performs one conversion for multiple channels (up to 8 channels can be set) , then halts.
Continuous conversion mode	Performs repeated conversions for the specified channel (1 channel) .	Performs repeated conversions for the specified channels (up to 8 channels can be set) .
Incremental conversion mode	Performs one conversion for the specified channel (1 channel) then halts and waits for the next activation.	Sequentially performs one conversion for multiple channels (up to 8 channels can be set) , then halts and waits for the next activation.

- **8/10-bit A/D converter interrupts and EI<sup>2</sup>OS**

Interrupt No.	Interrupt Control Register		Vector Table Address			EI <sup>2</sup> OS
	Register Name	Address	Lower	Upper	Bank	
#11 (0B <sub>H</sub> )	ICR00	0000B0 <sub>H</sub>	FFFFD0 <sub>H</sub>	FFFFD1 <sub>H</sub>	FFFFD2 <sub>H</sub>	○

○ : Available

• Block diagram

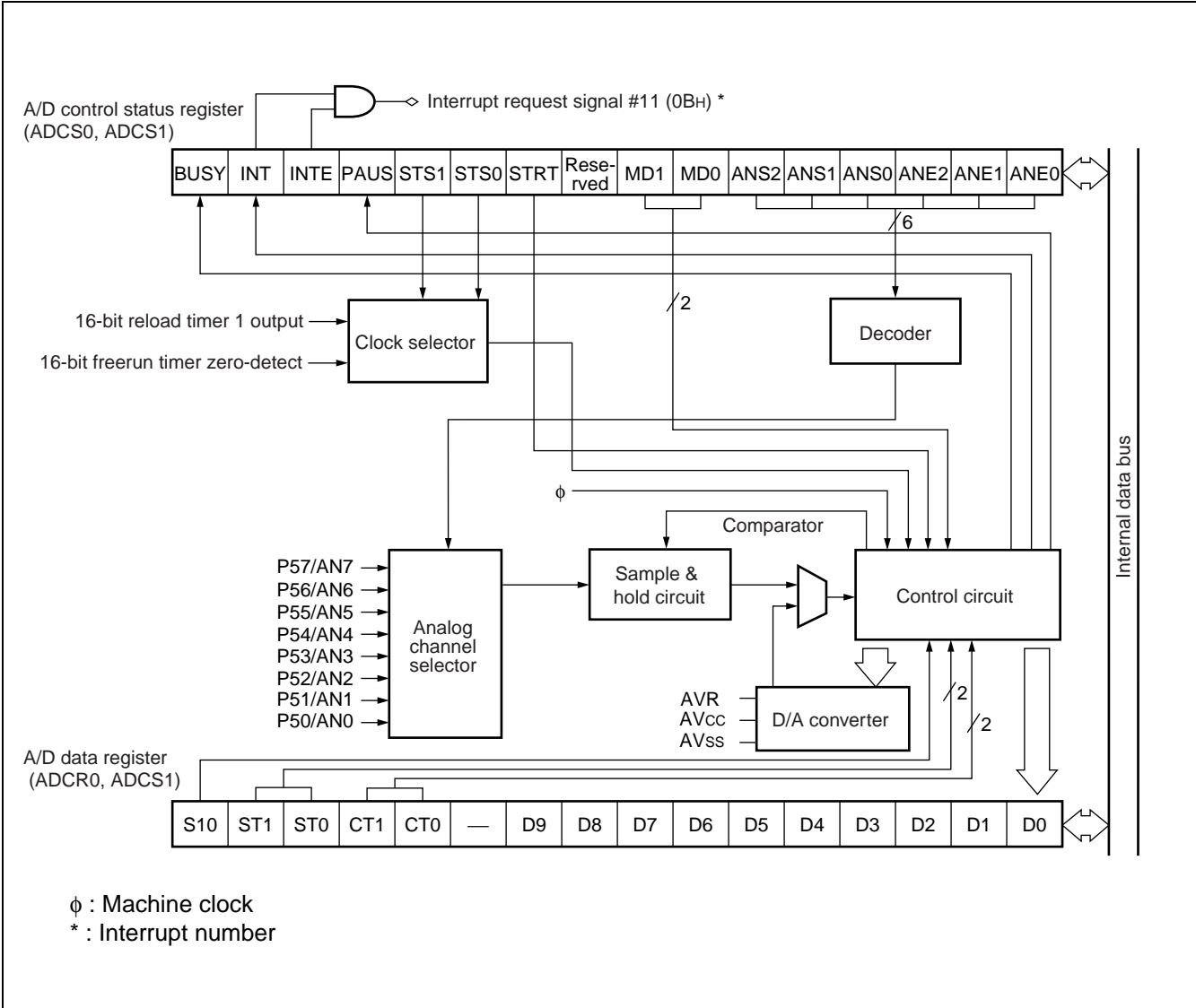

# MB90560/565 Series

## 10. ROM Mirror Function Selection Module

- The ROM mirror function selection module enables ROM data in FF bank to be read by accessing 00 bank.

### • ROM mirror function selection module functions

	Function
Mirror setting address	<ul style="list-style-type: none"> <li>Data in FFFFFFH to FF4000H in FF bank can be read from 00FFFFH to 004000H in 00 bank.</li> </ul>
Interrupts	<ul style="list-style-type: none"> <li>None</li> </ul>
EI <sup>2</sup> OS support	<ul style="list-style-type: none"> <li>Not supported by the extended intelligent I/O service (EI<sup>2</sup>OS) .</li> </ul>

### • Relationship between addresses in the ROM mirror function

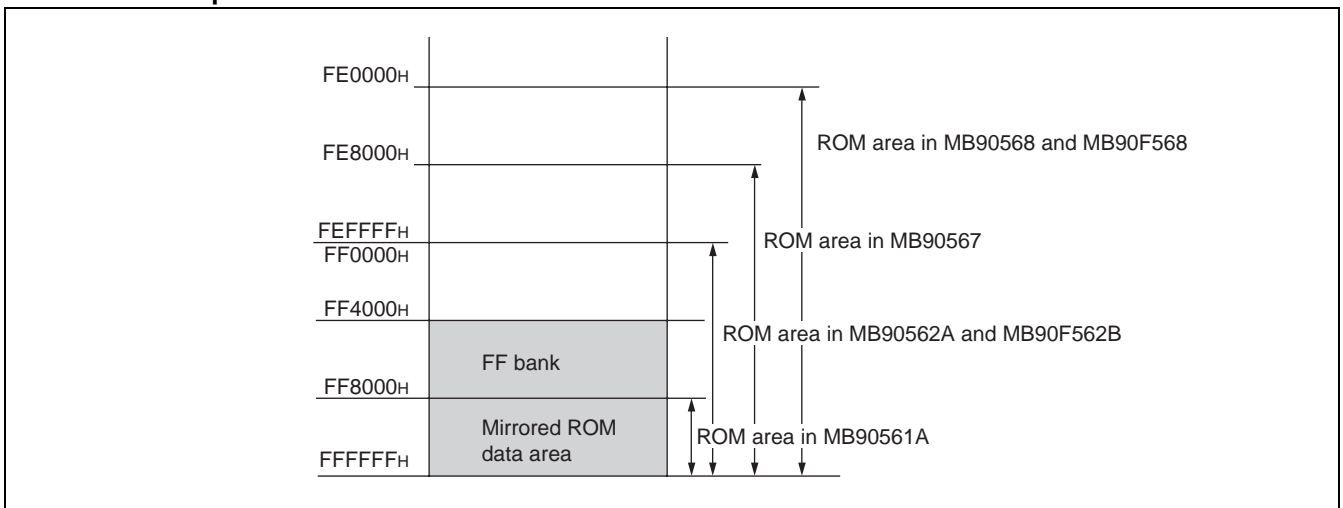

### • Block diagram

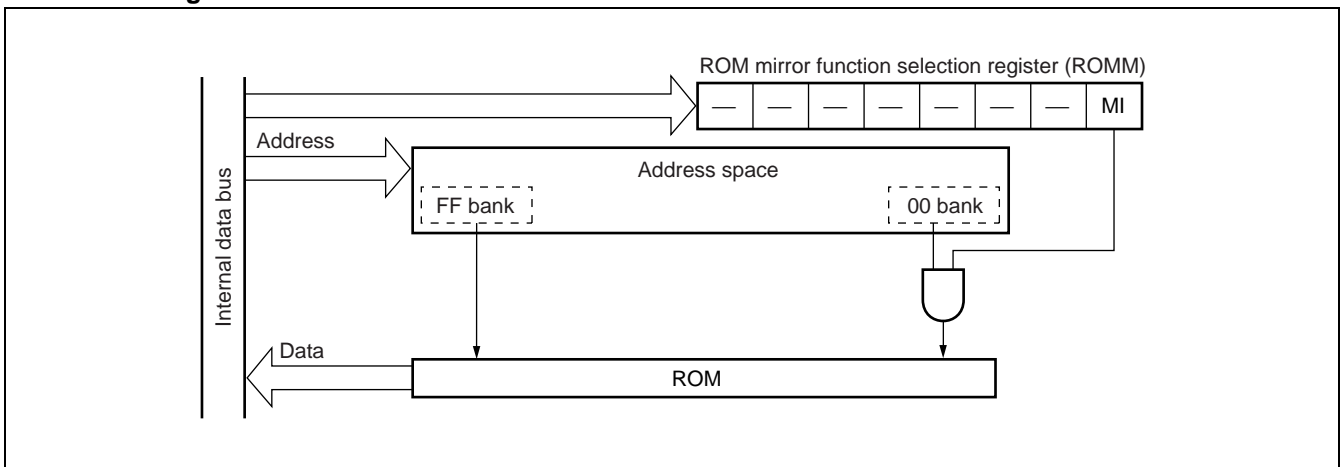

## 11. Low Power Consumption (Standby) Modes

- The power consumption of F<sup>2</sup>MC-16LX devices can be reduced by various settings that control the operating clock selection.

- Functions of each CPU operation mode

CPU Operation Clock	Operation Mode	Function
PLL clock	Normal Run	The CPU and peripheral functions operate using the oscillation clock (HCLK) multiplied by the PLL circuit.
	Sleep	The peripheral functions only operate using the oscillation clock (HCLK) multiplied by the PLL circuit.
	Pseudo-clock	The timebase timer only operates using the oscillation clock (HCLK) multiplied by the PLL circuit.
	Stop	The oscillation clock is stopped and the CPU and peripherals halt operation.
Main clock	Normal Run	The CPU and peripheral functions operate using the oscillation clock (HCLK) divided into 2.
	Sleep	The peripheral functions only operate using the oscillation clock (HCLK) divided into 2.
	Stop	The oscillation clock is stopped and the CPU and peripherals halt operation.
CPU intermittent operation	Normal Run	The oscillation clock (HCLK) divided into 2 operates intermittently for fixed time intervals.

# MB90560/565 Series

## 12. 512 Kbit Flash Memory

- This section describes the flash memory on the MB90F562B and does not apply to evaluation and mask ROM versions.
- The flash memory is located in bank FF in the CPU memory map.

### • Flash memory functions

	Function
Memory size	• 512 Kbit (64 KBytes)
Memory configuration	• 64 KWords × 8 bits or 32 KWords × 16 bits
Sector configuration	• 16 KBytes + 8 KBytes + 8 KBytes + 32 KBytes
Sector protect function	• Selectable for each sector
Programming algorithm	• Automatic programming algorithm (Embedded Algorithm : Equivalent to MBM29F400TA)
Operation commands	<ul style="list-style-type: none"> <li>• Compatible with JEDEC standard commands</li> <li>• Includes an erase pause and restart function</li> <li>• Write/erase completion detection by data polling or toggle bit</li> <li>• Erasing by sector available (sectors can be combined in any combination)</li> </ul>
No. of write/erase cycles	• Min. 10,000 guaranteed
Memory write/erase method	<ul style="list-style-type: none"> <li>• Can be written and erased using a parallel writer (Ando Denki AF9704, AF9705, AF9706, AF9708, and AF9709)</li> <li>• Can be written and erased using a dedicated serial writer (Yokogawa Digital Computer Corporation AF200, AF210, AF120, and AF110)</li> <li>• Can be written and erased by the program</li> </ul>
Interrupts	• Write and erase completion interrupts
EI <sup>2</sup> OS support	• Not supported by the extended intelligent I/O service (EI <sup>2</sup> OS) .

### • Sector configuration of flash memory

Flash memory	CPU address	Writer address*
SA1 (32 Kbyte)	FF0000H	70000H
	FF7FFFH	77FFFH
SA2 (8 Kbyte)	FF8000H	78000H
	FF9FFFH	79FFFH
SA3 (8 Kbyte)	FFA000H	7A000H
	FFBFFFH	7BFFFH
SA4 (16 Kbyte)	FFC000H	7C000H
	FEFFFFH	7FFFFH

\* : The writer address is the address to be used instead of the CPU address when writing data from a parallel flash memory writer. Use the writer address when programming or erasing with a general-purpose parallel writer.

## 13. 1 Mbit Flash Memory

- This section describes the flash memory on the MB90F568 and does not apply to evaluation and mask ROM versions.
- The flash memory is located in banks FE to FF in the CPU memory map.

### • Flash memory functions

	Function
Memory size	• 1 Mbit (128 KBytes)
Memory configuration	• 128 KWords × 8 bits or 64 KWords × 16 bits
Sector configuration	• 16 KBytes + 8 KBytes + 8 KBytes + 32 KBytes + 64 KBytes
Sector protect function	• Selectable for each sector
Programming algorithm	• Automatic programming algorithm (Embedded Algorithm : Equivalent to MBM29F400TA)
Operation commands	<ul style="list-style-type: none"> <li>• Compatible with JEDEC standard commands</li> <li>• Includes an erase pause and restart function</li> <li>• Write/erase completion detection by data polling or toggle bit</li> <li>• Erasing by sector available (sectors can be combined in any combination)</li> </ul>
No. of write/erase cycles	• Min. 10,000 guaranteed
Memory write/erase method	<ul style="list-style-type: none"> <li>• Can be written and erased using a parallel writer</li> <li>• Can be written and erased using a dedicated serial writer</li> <li>• Can be written and erased by the program</li> </ul>
Interrupts	• Write and erase completion interrupts
EI <sup>2</sup> OS support	• Not supported by the extended intelligent I/O service (EI <sup>2</sup> OS) .

### • Sector configuration of flash memory

Flash memory	CPU address	Writer address*
SA0 (64 Kbyte)	FE0000H	60000H
	FEFFFFH	6FFFFH
SA1 (32 Kbyte)	FF0000H	70000H
	FF7FFFH	77FFFH
SA2 (8 Kbyte)	FF8000H	78000H
	FF9FFFH	79FFFH
SA3 (8 Kbyte)	FFA000H	7A000H
	FFBFFFH	7BFFFH
SA4 (16 Kbyte)	FFC000H	7C000H
	FEFFFFH	7FFFFH

\* : The writer address is the address to be used instead of the CPU address when writing data from a parallel flash memory writer. Use the writer address when programming or erasing with a general-purpose parallel writer.

# MB90560/565 Series

## ■ ELECTRICAL CHARACTERISTICS (MB90560 SERIES)

### 1. Absolute Maximum Ratings

( $V_{SS} = AV_{SS} = 0.0\text{ V}$ )

Parameter	Symbol	Rating		Unit	Remarks
		Min.	Max.		
Power supply voltage	$V_{CC}$	$V_{SS} - 0.3$	$V_{SS} + 6.0$	V	
	$AV_{CC}$	$V_{SS} - 0.3$	$V_{SS} + 6.0$	V	$V_{CC} \geq AV_{CC}$ *1
	AVR	$V_{SS} - 0.3$	$V_{SS} + 6.0$	V	$AV_{CC} \geq AVR \geq 0\text{ V}$ *1
Input voltage	$V_I$	$V_{SS} - 0.3$	$V_{SS} + 6.0$	V	*2
Output voltage	$V_O$	$V_{SS} - 0.3$	$V_{SS} + 6.0$	V	*2
“L” level maximum output current	$I_{OL1}$	—	15	mA	*3, *4
	$I_{OL2}$	—	20	mA	*3, *5
“L” level average output current	$I_{OLAV1}$	—	4	mA	Average value (operating current $\times$ operating ratio)*4
	$I_{OLAV2}$	—	12	mA	Average value (operating current $\times$ operating ratio)*5
“L” level total maximum output current	$\Sigma I_{OL}$	—	100	mA	
“L” level total average output current	$\Sigma I_{OLAV}$	—	50	mA	Average value (operating current $\times$ operating ratio)
“H” level maximum output current	$I_{OH}$	—	-15	mA	*3
“H” level average output current	$I_{OHAV}$	—	-4	mA	Average value (operating current $\times$ operating ratio)
“H” level total maximum output current	$\Sigma I_{OH}$	—	-100	mA	
“H” level total average output current	$\Sigma I_{OHAV}$	—	-50	mA	Average value (operating current $\times$ operating ratio)
Power consumption	$P_d$	—	300	mW	
Operating temperature	$T_A$	-40	+85	°C	
Storage temperature	$T_{stg}$	-55	+150	°C	

\*1 :  $AV_{CC}$  and AVR must not exceed  $V_{CC}$ . Also, AVR must not exceed  $AV_{CC}$ .

\*2 :  $V_I$  and  $V_O$  must not exceed  $V_{CC} + 0.3\text{ V}$ .

\*3 : The maximum output current is the peak value for a single pin.

\*4 : Pins other than P30/RTO0 to P35/RTO5

\*5 : P30/RTO0 to P35/RTO5 pins

WARNING: Semiconductor devices can be permanently damaged by application of stress (voltage, current, temperature, etc.) in excess of absolute maximum ratings. Do not exceed these ratings.

## 2. Recommended Operating Conditions

( $V_{SS} = AV_{SS} = 0.0\text{ V}$ )

Parameter	Symbol	Value		Unit	Remarks
		Min.	Max.		
Power supply voltage	$V_{CC}$	3.0	5.5	V	Normal operation (MB90562A, MB90561A, and MB90V560)
		4.5	5.5	V	Normal operation (MB90F562B)
	$V_{CC}$	3.0	5.5	V	Maintaining state in stop mode
Input "H" voltage	$V_{IH}$	$0.7 V_{CC}$	$V_{CC} + 0.3$	V	CMOS input pin
	$V_{IHS}$	$0.8 V_{CC}$	$V_{CC} + 0.3$	V	CMOS hysteresis input pin
	$V_{IHM}$	$V_{CC} - 0.3$	$V_{CC} + 0.3$	V	MD input pin
Input "L" voltage	$V_{IL}$	$V_{SS} - 0.3$	$0.3 V_{CC}$	V	CMOS input pin
	$V_{ILS}$	$V_{SS} - 0.3$	$0.2 V_{CC}$	V	CMOS hysteresis input pin
	$V_{ILM}$	$V_{SS} - 0.3$	$V_{SS} + 0.3$	V	MD input pin
Smoothing capacitor	$C_S$	0.1	1.0	$\mu\text{F}$	Use a ceramic capacitor or other capacitor with equivalent frequency characteristics. The capacitance of the smoothing capacitor connected to the $V_{CC}$ pin must be greater than $C_S$ .
Operating temperature	$T_A$	-40	+85	$^{\circ}\text{C}$	

- C pin diagram

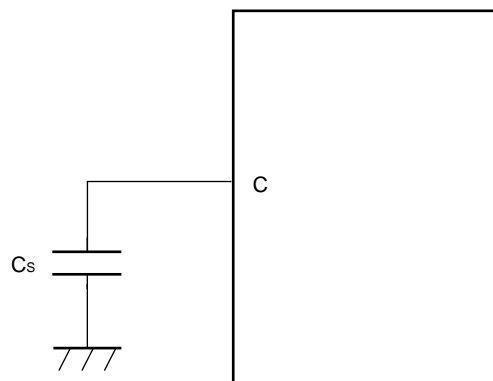

**WARNING:** The recommended operating conditions are required in order to ensure the normal operation of the semiconductor device. All of the device's electrical characteristics are warranted when the device is operated within these ranges.

Always use semiconductor devices within their recommended operating condition ranges. Operation outside these ranges may adversely affect reliability and could result in device failure.

No warranty is made with respect to uses, operating conditions, or combinations not represented on the data sheet. Users considering application outside the listed conditions are advised to contact their representatives beforehand.

# MB90560/565 Series

## 3. DC Characteristics

( $T_A = -40\text{ }^\circ\text{C}$  to  $+85\text{ }^\circ\text{C}$ ,  $V_{CC} = 5.0\text{ V} \pm 10\%$ ,  $V_{SS} = AV_{SS} = 0.0\text{ V}$ )

Parameter	Symbol	Pin Name	Condition	Value			Unit	Remarks
				Min.	Typ.	Max.		
Output "H" voltage	$V_{OH}$	All output pins	$V_{CC} = 4.5\text{ V}$ $I_{OH} = -2.0\text{ mA}$	$V_{CC} - 0.5$	—	—	V	
Output "L" voltage	$V_{OL1}$	Pins other than P30/RTO0 to P35/RTO5	$V_{CC} = 4.5\text{ V}$ $I_{OL1} = 2.0\text{ mA}$	—	—	0.4	V	
	$V_{OL2}$	P30/RTO0 to P35/RTO5	$V_{CC} = 4.5\text{ V}$ $I_{OL2} = 12.0\text{ mA}$	—	—	0.8	V	
Input leak current	$I_{IL}$	All output pins	$V_{CC} = 5.5\text{ V}$ $V_{SS} < V_I < V_{CC}$	-5	—	5	$\mu\text{A}$	
Power supply current*	$I_{CC}$	$V_{CC}$	For $V_{CC} = 5\text{ V}$ , internal frequency = 16 MHz, normal operation	—	50	80	mA	MB90562A, MB90561A
				—	40	50	mA	MB90F562B
			For $V_{CC} = 5\text{ V}$ , internal frequency = 16 MHz, A/D operation in progress	—	55	85	mA	MB90562A, MB90561A
			Flash write or erase	—	45	55	mA	MB90F562B
	$I_{CCS}$		For $V_{CC} = 5\text{ V}$ , internal frequency = 16 MHz, sleep mode	—	15	20	mA	MB90562A, MB90561A, MB90F562B*
	$I_{CCH}$		Stop mode, $T_A = 25\text{ }^\circ\text{C}$	—	5	20	$\mu\text{A}$	
Input capacitance	$C_{IN}$	Other than $AV_{CC}$ , $AV_{SS}$ , C, $V_{CC}$ , and $V_{SS}$	—	—	10	80	pF	
Pull-up resistor	$R_{UP}$	P00 to P07 P10 to P17 $\overline{RST}$	—	15	30	100	k $\Omega$	
Pull-down resistor	$R_{DOWN}$	MD2	—	15	30	100	k $\Omega$	Only for mask ROM products

\* : Value when low power mode bits (LPM0, 1) is set to "01" with an internal operating frequency of 4 MHz.

Note : Current values are provisional and are subject to change without notice to allow for improvements to the characteristics. The power supply current is measured with an external clock.

## 4. AC Characteristics

### (1) Clock Timings

( $T_A = -40\text{ }^\circ\text{C}$  to  $+85\text{ }^\circ\text{C}$ ,  $V_{CC} = 5.0\text{ V} \pm 10\%$ ,  $V_{SS} = AV_{SS} = 0.0\text{ V}$ )

Parameter	Symbol	Pin Name	Condition	Value			Unit	Remarks
				Min.	Typ.	Max.		
Clock frequency	$f_C$	X0, X1	—	3	—	16	MHz	With a PLL circuit
				1	—	16		Without a PLL circuit
Clock cycle time	$t_{HCYL}$	X0, X1	—	62.5	—	333	ns	With a PLL circuit
				62.5	—	1000		Without a PLL circuit
Input clock pulse width	$P_{WH}$ $P_{WL}$	X0	—	10	—	ns	Recommended duty ratio = 30% to 70%	
Input clock rise/fall time	$t_{cr}$ $t_{cf}$	X0	—	—	—	ns	When using an external clock	
Internal operating clock frequency	$f_{CP}$	—	—	1.5	—	16	MHz	When using a main clock
Internal operating clock cycle time	$t_{CP}$	—	—	62.5	—	333	ns	When using a main clock

#### • X0 and X1 clock timing

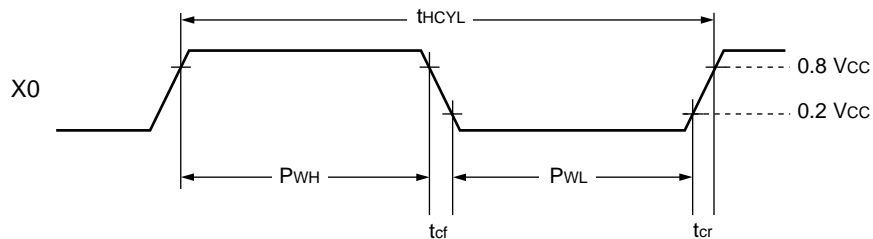

# MB90560/565 Series

## • PLL guaranteed operation range

Relationship between internal operating clock frequency and power supply voltage

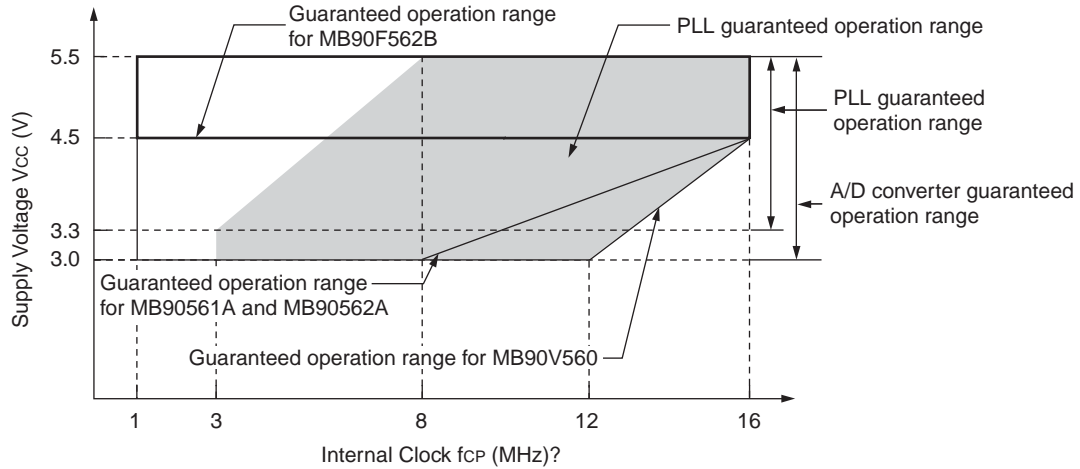

Relationship between oscillation frequency and internal operating clock frequency

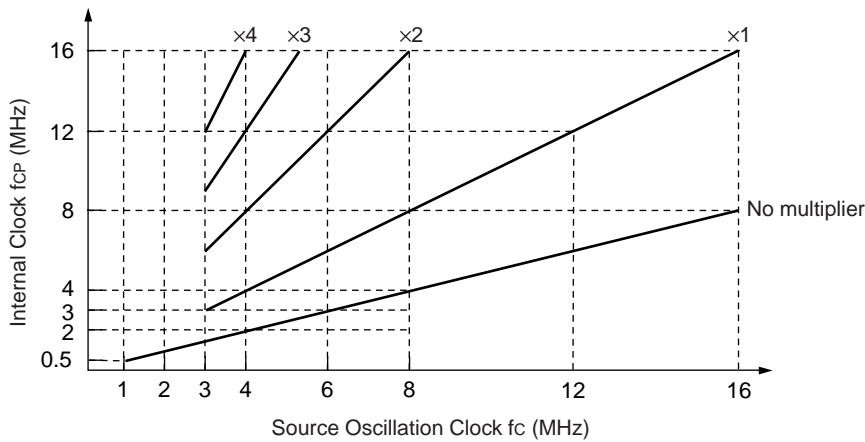

The AC ratings are specified for the following measurement reference voltages.

### • Input signal waveform

Hysteresis input pin

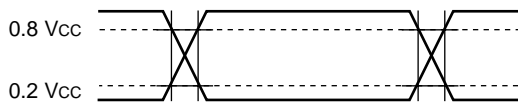

Pins other than hysteresis input or MD input pins

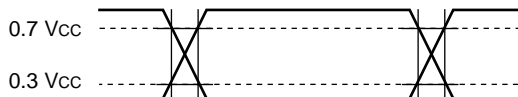

### • Output signal waveform

Output pin

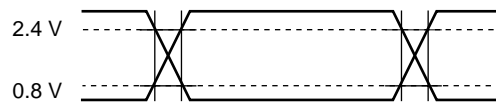

## (2)Reset

( $T_A = -40\text{ }^\circ\text{C}$  to  $+85\text{ }^\circ\text{C}$ ,  $V_{CC} = 5.0\text{ V} \pm 10\%$ ,  $V_{SS} = AV_{SS} = 0.0\text{ V}$ )

Parameter	Symbol	Pin Name	Condition	Value		Unit	Remarks
				Min.	Max.		
Reset input time	$t_{RSTH}$	$\overline{RST}$	—	16 $t_{CP}$	—	ns	In normal operation
				Oscillator oscillation time* + 16 $t_{CP}$	—	ms	In stop mode

\*: Oscillator oscillation time is the time to reach 90% amplitude. For a crystal oscillator, this is a few to several dozen ms; for a ceramic oscillator, this is several hundred  $\mu\text{s}$  to a few ms, and for an external clock this is 0 ms.

- In normal operation

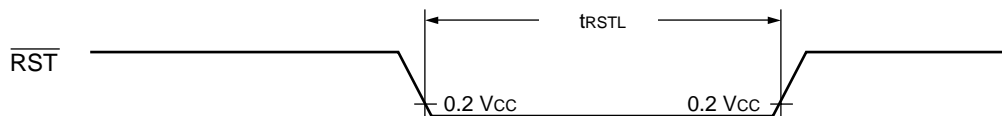

- In stop mode

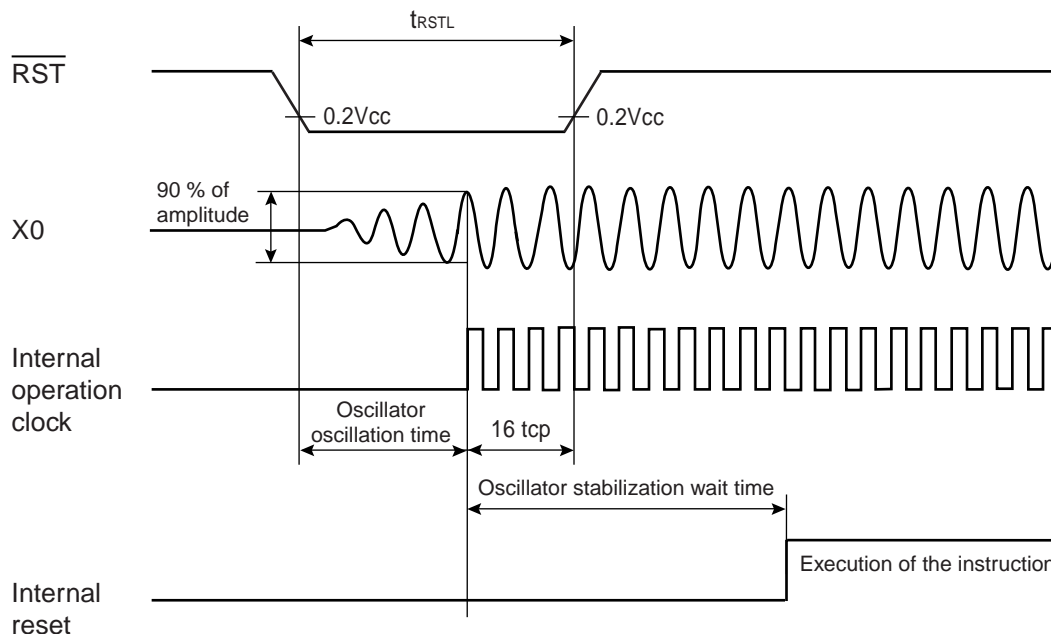

# MB90560/565 Series

## (3) Power-On Reset

( $T_A = -40\text{ }^\circ\text{C}$  to  $+85\text{ }^\circ\text{C}$ ,  $V_{CC} = 5.0\text{ V} \pm 10\%$ ,  $V_{SS} = AV_{SS} = 0.0\text{ V}$ )

Parameter	Symbol	Pin Name	Condi- tion	Value		Unit	Remarks
				Min.	Max.		
Power supply rise time	$t_R$	$V_{CC}$	—	0.05	30	ms	
Power supply cutoff time	$t_{OFF}$	$V_{CC}$	—	4	—	ms	For repeated operation

Note:  $V_{CC}$  must be less than 0.2 V before power-on.

- Notes :
- The above rating values are for generating a power-on reset.
  - Some internal registers are only initialized by a power-on reset. Always apply the power supply in accordance with the above ratings if you wish to initialize these registers.

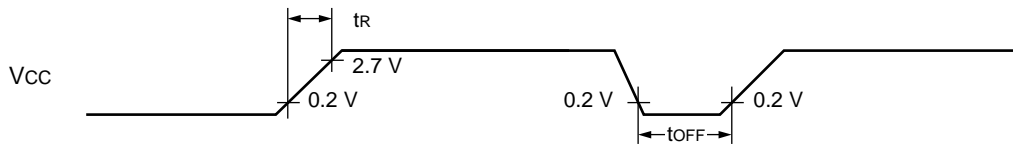

Sudden changes in the power supply voltage may cause a power-on reset. The recommended practice if you wish to change the power supply voltage while the device is operating is to raise the voltage smoothly as shown below. Also, changes to the supply voltage should be performed when the PLL clock is not in use. The PLL clock may be used, however, if the rate of voltage change is 1 V/s or less.

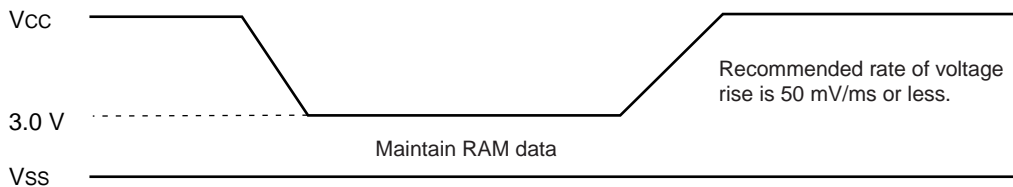

## (4) UART0, UART1, and I/O Expansion Serial Timings

( $T_A = -40\text{ }^\circ\text{C}$  to  $+85\text{ }^\circ\text{C}$ ,  $V_{CC} = 5.0\text{ V} \pm 10\%$ ,  $V_{SS} = AV_{SS} = 0.0\text{ V}$ )

Parameter	Symbol	Pin Name	Condition	Value		Unit	Remarks
				Min.	Max.		
Serial clock cycle time	$t_{SCYC}$	SCK0, SCK1	Internal shift clock mode, output pin load is $CL = 80\text{ pF} + 1\text{ TTL}$	$8 t_{CP}$	—	ns	
SCK $\downarrow \rightarrow$ SOT delay time	$t_{SLOV}$	SCK0, SCK1 SOT0, SOT1		-80	80	ns	
Valid SIN $\rightarrow$ SCK $\uparrow$	$t_{IVSH}$	SCK0, SCK1 SIN0, SIN1		100	—	ns	
SCK $\uparrow \rightarrow$ valid SIN hold time	$t_{SHIX}$	SCK0, SCK1 SIN0, SIN1		60	—	ns	
Serial clock "H" pulse width	$t_{SHSL}$	SCK0, SCK1	External shift clock mode, output pin load is $CL = 80\text{ pF} + 1\text{ TTL}$	$4 t_{CP}$	—	ns	
Serial clock "L" pulse width	$t_{SLSH}$	SCK0, SCK1		$4 t_{CP}$	—	ns	
SCK $\downarrow \rightarrow$ SOT delay time	$t_{SLOV}$	SCK0, SCK1 SOT0, SOT1		—	150	ns	
Valid SIN $\rightarrow$ SCK $\uparrow$	$t_{IVSH}$	SCK0, SCK1 SIN0, SIN1		60	—	ns	
SCK $\uparrow \rightarrow$ valid SIN hold time	$t_{SHIX}$	SCK0, SCK1 SIN0, SIN1		60	—	ns	

- Notes :
- These are the AC ratings for CLK synchronous mode.
  - $C_L$  is the load capacitor connected to the pin for testing.
  - $t_{CP}$  is the machine cycle period (unit = ns)

# MB90560/565 Series

## • Internal shift clock mode

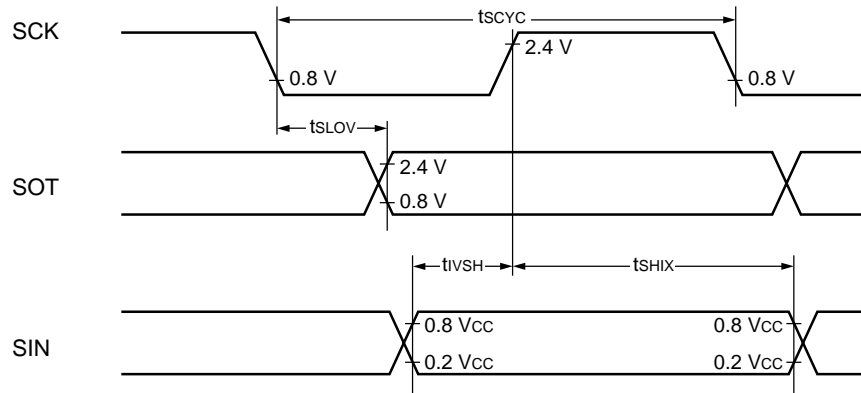

## • External shift clock mode

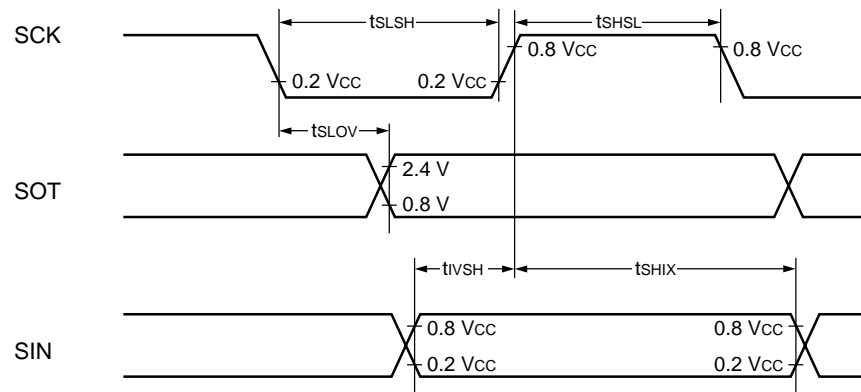

## (5) Timer Input Timings

( $T_A = -40\text{ }^\circ\text{C}$  to  $+85\text{ }^\circ\text{C}$ ,  $V_{CC} = 5.0\text{ V} \pm 10\%$ ,  $V_{SS} = AV_{SS} = 0.0\text{ V}$ )

Parameter	Symbol	Pin Name	Condition	Value		Unit	Remarks
				Min.	Max.		
Input pulse width	$t_{TIWH}$ , $t_{TIWL}$	FRCK, IN0, IN1, TIN0, TIN1	—	$4 t_{CP}$	—	ns	

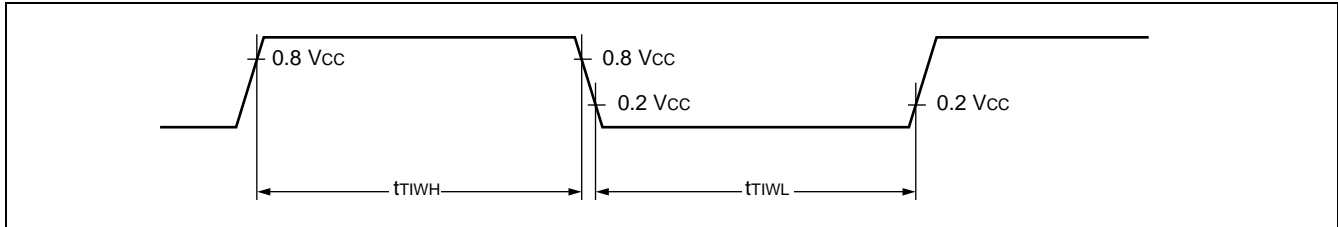

## (6) Timer Output Timings

( $T_A = -40\text{ }^\circ\text{C}$  to  $+85\text{ }^\circ\text{C}$ ,  $V_{CC} = 5.0\text{ V} \pm 10\%$ ,  $V_{SS} = AV_{SS} = 0.0\text{ V}$ )

Parameter	Symbol	Pin Name	Condition	Value		Unit	Remarks
				Min.	Max.		
CLK $\uparrow$ $\rightarrow$ TOUT change time	$t_{TO}$	RTO0 to RTO5, PPG0 to PPG5, TO0 to TO1	—	30	—	ns	

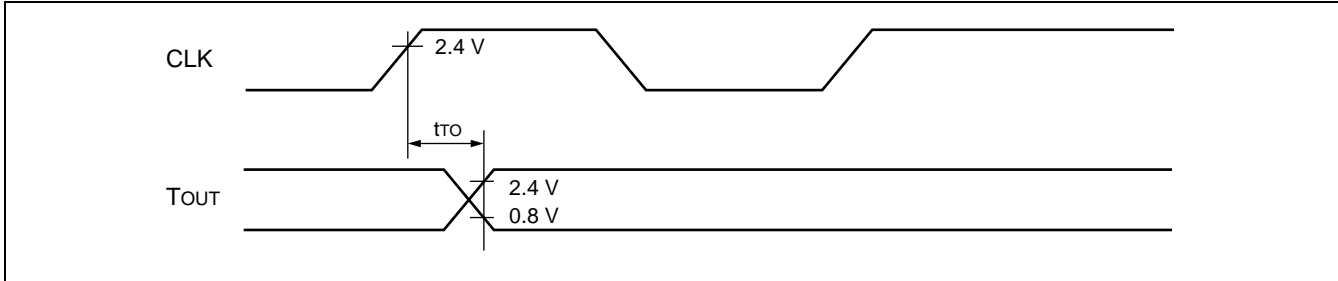

## (7) Trigger Input Timings

( $T_A = -40\text{ }^\circ\text{C}$  to  $+85\text{ }^\circ\text{C}$ ,  $V_{CC} = 5.0\text{ V} \pm 10\%$ ,  $V_{SS} = AV_{SS} = 0.0\text{ V}$ )

Parameter	Symbol	Pin Name	Condition	Value		Unit	Remarks
				Min.	Max.		
Input pulse width	$t_{TRGL}$	INT0 to INT7, IN0 to IN3	—	$5 t_{CP}$	—	ns	In normal operation
				1	—	$\mu\text{s}$	In stop mode

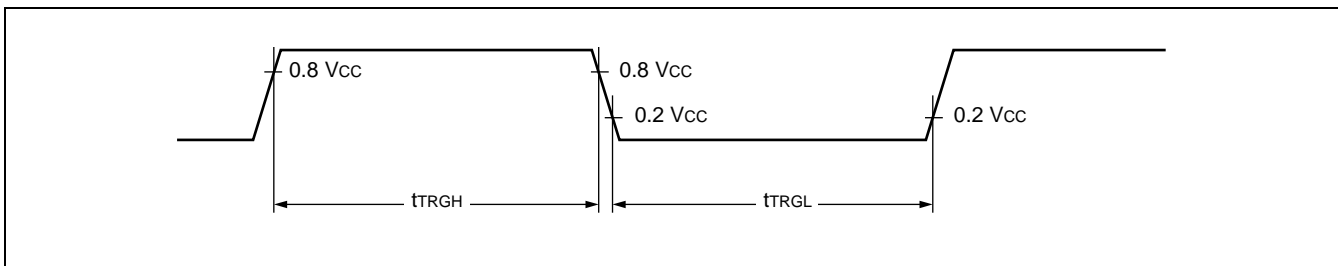

# MB90560/565 Series

## 5. Electrical Characteristics for the A/D Converter

( $T_A = -40\text{ }^\circ\text{C}$  to  $+85\text{ }^\circ\text{C}$ ,  $3.0\text{ V} \leq \text{AVR}$ ,  $V_{CC} = \text{AV}_{CC} = 5.0\text{ V} \pm 10\%$ ,  $V_{SS} = \text{AV}_{SS} = 0.0\text{ V}$ )

Parameter	Symbol	Pin Name	Value			Unit	Remarks
			Min.	Typ.	Max.		
Resolution	—	—	—	10	—	bit	
Total error	—	—	—	—	$\pm 5.0$	LSB	
Non-linearity error	—	—	—	—	$\pm 2.5$	LSB	
Differential linearity error	—	—	—	—	$\pm 1.9$	LSB	
Zero transition voltage	$V_{OT}$	AN0 to AN7	$\text{AV}_{SS}$ -3.5 LSB	$\text{AV}_{SS}$ +0.5 LSB	$\text{AV}_{SS}$ +4.5 LSB	V	1 LSB = $(\text{AVR} - \text{AV}_{SS}) / 1024$
Full-scale transition voltage	$V_{FST}$	AN0 to AN7	AVR -6.5 LSB	AVR -1.5 LSB	AVR +1.5 LSB	V	
Conversion time	—	—	—	176 $t_{CP}$	—	ns	
Sampling time	—	—	—	64 $t_{CP}$	—	ns	
Analog port input current	$I_{AIN}$	AN0 to AN7	—	—	10	$\mu\text{A}$	
Analog input voltage	$V_{AIN}$	AN0 to AN7	0	—	AVR	V	
Reference voltage	—	AVR	2.7	—	$\text{AV}_{CC}$	V	
Power supply current	$I_A$	$\text{AV}_{CC}$	—	5	—	mA	
	$I_{AH}$	$\text{AV}_{CC}$	—	—	5	$\mu\text{A}$	*
Reference voltage supply current	$I_R$	AVR	—	400	—	$\mu\text{A}$	
	$I_{RH}$	AVR	—	—	5	$\mu\text{A}$	*
Variation between channels	—	AN0 to AN7	—	—	4	LSB	

\* : Current when A/D converter is not used and CPU is in stop mode ( $V_{CC} = \text{AV}_{CC} = \text{AVR} = 5.0\text{ V}$ )

Notes : • The L reference voltage is fixed to  $\text{AV}_{SS}$ . The relative error increases as AVR becomes smaller.

- Ensure that the output impedance of the external circuit connected to the analog input meets the following condition :

Output impedance of external circuit  $\leq 10\text{ k}\Omega$  (Sampling Time =  $4.0\text{ }\mu\text{s}$ )

- If the output impedance of the external circuit is too high, the analog voltage sampling time may be too short.

### • Equivalent circuit of analog input circuit

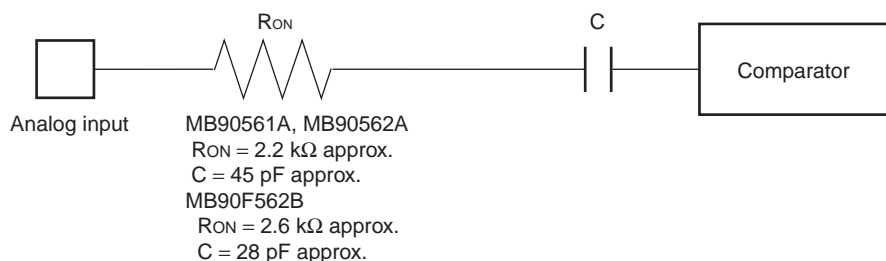

Note : The values listed are an indication only.

## 6. Flash Memory Erase and Programming Performance

Parameter	Condition	Value			Units	Remarks
		Min	Typ	Max		
Sector erase time	T <sub>A</sub> = + 25 °C V <sub>CC</sub> = 5.0 V	—	1	15	s	Excludes 00H programming prior erasure
Chip erase time		—	5	—	s	Excludes 00H programming prior erasure
Word (16 bit width) programming time		—	16	3,600	μs	Excludes system-level overhead
Erase/Program cycle	—	10,000	—	—	cycle	
Data holding time	—	100,000	—	—	h	

# MB90560/565 Series

## ■ ELECTRICAL CHARACTERISTICS (MB90565 SERIES)

### 1. Absolute Maximum Ratings

( $V_{SS} = AV_{SS} = 0.0\text{ V}$ )

Parameter	Symbol	Rating		Unit	Remarks
		Min.	Max.		
Power supply voltage	$V_{CC}$	$V_{SS} - 0.3$	$V_{SS} + 4.0$	V	
	$AV_{CC}$	$V_{SS} - 0.3$	$V_{SS} + 4.0$	V	$V_{CC} \geq AV_{CC}$ *1
	AVR	$V_{SS} - 0.3$	$V_{SS} + 4.0$	V	$AV_{CC} \geq AVR \geq 0\text{ V}$ *1
Input voltage	$V_I$	$V_{SS} - 0.3$	$V_{SS} + 4.0$	V	*2
Output voltage	$V_O$	$V_{SS} - 0.3$	$V_{SS} + 4.0$	V	*2
"L" level maximum output current	$I_{OL}$	—	15	mA	*3
"L" level average output current	$I_{OLAV}$	—	4	mA	Average value (operating current $\times$ operating ratio)
"L" level total maximum output current	$\Sigma I_{OL}$	—	100	mA	
"L" level total average output current	$\Sigma I_{OLAV}$	—	50	mA	Average value (operating current $\times$ operating ratio)
"H" level maximum output current	$I_{OH}$	—	-15	mA	*3
"H" level average output current	$I_{OHAV}$	—	-4	mA	Average value (operating current $\times$ operating ratio)
"H" level total maximum output current	$\Sigma I_{OH}$	—	-100	mA	
"H" level total average output current	$\Sigma I_{OHAV}$	—	-50	mA	Average value (operating current $\times$ operating ratio)
Power consumption	$P_d$	—	300	mW	
Operating temperature	$T_A$	-40	+85	°C	
Storage temperature	$T_{stg}$	-55	+150	°C	

\*1 :  $AV_{CC}$  and AVR must not exceed  $V_{CC}$ . Also, AVR must not exceed  $AV_{CC}$ .

\*2 :  $V_I$  and  $V_O$  must not exceed  $V_{CC} + 0.3\text{ V}$ .

\*3 : The maximum output current is the peak value for a single pin.

**WARNING:** Semiconductor devices can be permanently damaged by application of stress (voltage, current, temperature, etc.) in excess of absolute maximum ratings. Do not exceed these ratings.

## 2. Recommended Operating Conditions

( $V_{SS} = AV_{SS} = 0.0\text{ V}$ )

Parameter	Symbol	Value		Unit	Remarks
		Min.	Max.		
Power supply voltage	$V_{CC}$	3.0	3.6	V	Normal operation (MB90V560)
		2.7	3.6	V	Normal operation (MB90F568, MB90567 and MB90568)
		2.5	3.6	V	Maintaining state in stop mode
Input "H" voltage	$V_{IH}$	$0.7 V_{CC}$	$V_{CC} + 0.3$	V	CMOS input pin
	$V_{IHS}$	$0.8 V_{CC}$	$V_{CC} + 0.3$	V	CMOS hysteresis input pin
	$V_{IHM}$	$V_{CC} - 0.3$	$V_{CC} + 0.3$	V	MD input pin
Input "L" voltage	$V_{IL}$	$V_{SS} - 0.3$	$0.3 V_{CC}$	V	CMOS input pin
	$V_{ILS}$	$V_{SS} - 0.3$	$0.2 V_{CC}$	V	CMOS hysteresis input pin
	$V_{ILM}$	$V_{SS} - 0.3$	$V_{SS} + 0.3$	V	MD input pin
Operating temperature	$T_A$	-40	+85	°C	

**WARNING:** The recommended operating conditions are required in order to ensure the normal operation of the semiconductor device. All of the device's electrical characteristics are warranted when the device is operated within these ranges.

Always use semiconductor devices within their recommended operating condition ranges. Operation outside these ranges may adversely affect reliability and could result in device failure.

No warranty is made with respect to uses, operating conditions, or combinations not represented on the data sheet. Users considering application outside the listed conditions are advised to contact their representatives beforehand.

# MB90560/565 Series

## 3. DC Characteristics

( $T_A = -40\text{ }^{\circ}\text{C}$  to  $+85\text{ }^{\circ}\text{C}$ ,  $V_{CC} = 2.7\text{ V}$  to  $3.6\text{ V}$ ,  $V_{SS} = AV_{SS} = 0.0\text{ V}$ )

Parameter	Symbol	Pin Name	Condition	Value			Unit	Remarks
				Min.	Typ.	Max.		
Output "H" voltage	$V_{OH}$	All output pins	$V_{CC} = 3.0\text{ V}$ $I_{OH} = -2.0\text{ mA}$	$V_{CC} - 0.5$	$V_{CC} - 0.3$	—	V	
Output "L" voltage	$V_{OL}$	All output pins	$V_{CC} = 3.0\text{ V}$ $I_{OL} = 2.0\text{ mA}$	—	0.2	0.4	V	
Input leak current	$I_{IL}$	All output pins	$V_{CC} = 3.0\text{ V}$ $V_{SS} < V_i < V_{CC}$	-5	-1	5	$\mu\text{A}$	
Power supply current*	$I_{CC}$	$V_{CC}$	For $V_{CC} = 3.3\text{ V}$ , internal frequency = 8 MHz, normal operation	—	14	22	mA	MB90567/568
			For $V_{CC} = 3.3\text{ V}$ , internal frequency = 16 MHz, normal operation	—	27	40	mA	MB90567/568
			For $V_{CC} = 3.3\text{ V}$ , internal frequency = 8 MHz, A/D operation in progress	—	18	27	mA	MB90567/568
			For $V_{CC} = 3.3\text{ V}$ , internal frequency = 16 MHz, A/D operation in progress	—	32	45	mA	MB90567/568
			For $V_{CC} = 3.3\text{ V}$ , internal frequency = 8 MHz, normal operation	—	18	28	mA	MB90F568
			For $V_{CC} = 3.3\text{ V}$ , internal frequency = 16 MHz, normal operation	—	36	45	mA	MB90F568
			For $V_{CC} = 3.3\text{ V}$ , internal frequency = 8 MHz, A/D operation in progress	—	23	33	mA	MB90F568
			For $V_{CC} = 3.3\text{ V}$ , internal frequency = 16 MHz, A/D operation in progress	—	41	50	mA	MB90F568
			Flash write or erase	—	40	50	mA	MB90F568
	$I_{CCS}$	$V_{CC}$	For $V_{CC} = 3.3\text{ V}$ , internal frequency = 8 MHz, sleep mode	—	6	10	mA	MB90567/568 MB90F568*
			For $V_{CC} = 3.3\text{ V}$ , internal frequency = 16 MHz, sleep mode	—	14	20	mA	MB90567/568 MB90F568*
	$I_{CCH}$		Stop mode, $T_A = 25\text{ }^{\circ}\text{C}$	—	5	20	$\mu\text{A}$	

\* : Value when low power mode bits (LPM0, 1) are set to "01" with an internal operating frequency of 8 MHz.

(Continued)

# MB90560/565 Series

(Continued)

Parameter	Symbol	Pin Name	Condition	Value			Unit	Remarks
				Min.	Typ.	Max.		
Pull-up resistor	R <sub>UP</sub>	P00 to P07 P10 to P17 $\overline{\text{RST}}$	—	20	65	200	k $\Omega$	
Pull-down resistor	R <sub>DOWN</sub>	MD2	—	20	65	200	k $\Omega$	Only for mask ROM products

Note : Current values are provisional and are subject to change without notice to allow for improvements to the characteristics. The power supply current is measured with an external clock.

# MB90560/565 Series

## 4. AC Characteristics

### (1) Clock Timings

(MB90567/568/F568 :  $T_A = -40\text{ }^\circ\text{C}$  to  $+85\text{ }^\circ\text{C}$ ,  $V_{CC} = 2.7\text{ V}$  to  $3.6\text{ V}$ ,  $V_{SS} = AV_{SS} = 0.0\text{ V}$ )

(MB90V560 :  $T_A = +25\text{ }^\circ\text{C}$ ,  $V_{CC} = 2.7\text{ V}$  to  $3.6\text{ V}$ ,  $V_{SS} = AV_{SS} = 0.0\text{ V}$ )

Parameter	Symbol	Pin Name	Condition	Value			Unit	Remarks
				Min.	Typ.	Max.		
Clock frequency	$f_c$	X0, X1	—	3	—	12	MHz	MB90V560
				3	—	16	MHz	MB90567/568 MB90F568
Clock cycle time	$t_{HCYL}$	X0, X1	—	83.3	—	333	ns	MB90V560
				62.5	—	333	ns	MB90567/568 MB90F568
Input clock pulse width	$P_{WH}$ $P_{WL}$	X0	—	10	—	—	ns	Recommended duty ratio = 30% to 70%
Input clock rise/fall time	$t_{cr}$ $t_{cf}$	X0	—	—	—	5	ns	When using an external clock
Internal operating clock frequency	$f_{CP}$	—	—	1.5	—	12	MHz	MB90V560
				1.5	—	16	MHz	MB90567/568 MB90F568
Internal operating clock cycle time	$t_{CP}$	—	—	83.3	—	666	ns	MB90V560
				62.5	—	666	ns	MB90567/568 MB90F568

#### • X0 and X1 clock timing

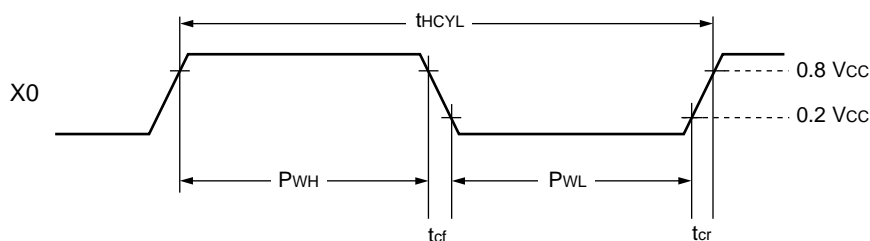

• **PLL guaranteed operation range**

Relationship between internal operating clock frequency and power supply voltage

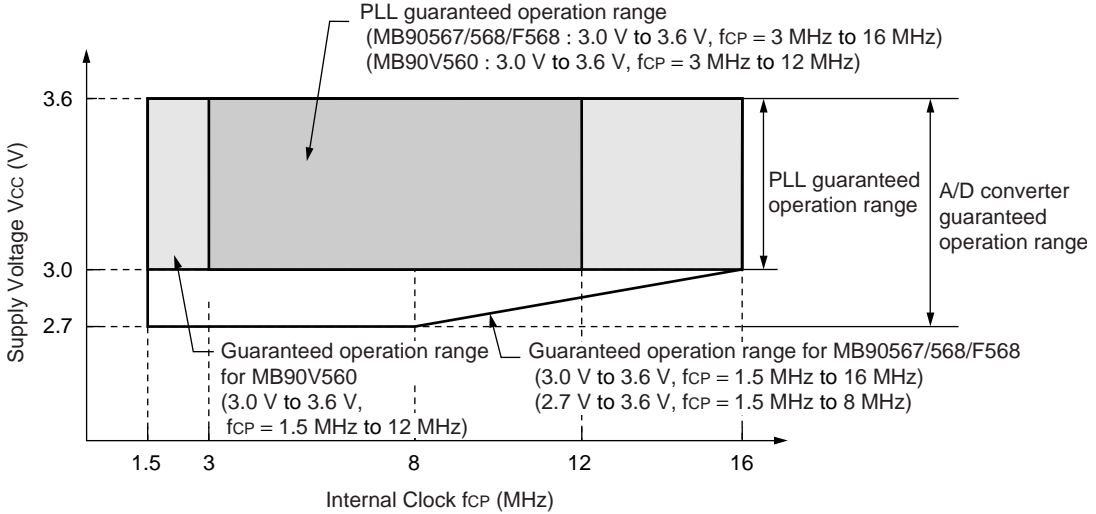

Relationship between oscillation frequency and internal operating clock frequency

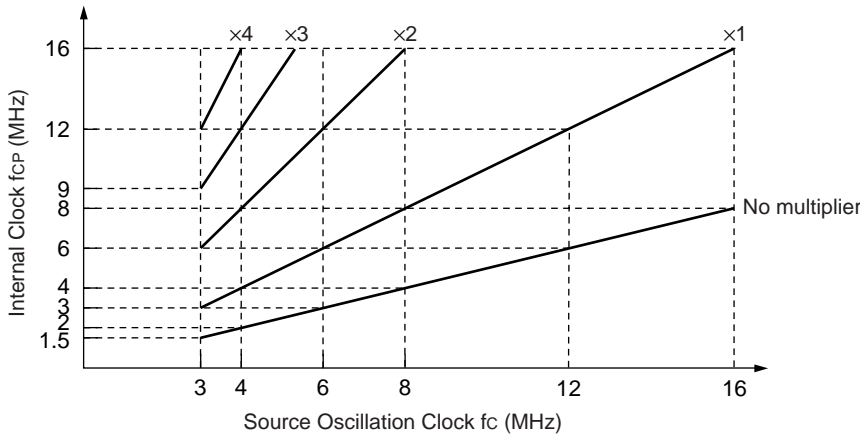

The AC ratings are specified for the following measurement reference voltages.

• **Input signal waveform**

• **Output signal waveform**

**Hysteresis input pin**



**Output pin**



**Pins other than hysteresis input or MD input pins**

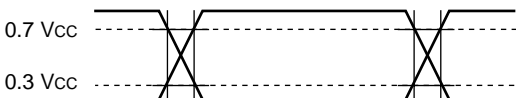

# MB90560/565 Series

## (2) Reset

( $T_A = -40\text{ }^\circ\text{C}$  to  $+85\text{ }^\circ\text{C}$ ,  $V_{CC} = 2.7\text{ V}$  to  $3.6\text{ V}$ ,  $V_{SS} = AV_{SS} = 0.0\text{ V}$ )

Parameter	Symbol	Pin Name	Condition	Value		Unit	Remarks
				Min.	Max.		
Reset input time	$t_{RSTL}$	$\overline{RST}$	—	16 $t_{CP}$	—	ns	In normal operation
				Oscillator oscillation time* + 16 $t_{CP}$	—	ms	In stop mode

\*: Oscillator oscillation time is the time to reach 90% amplitude. For a crystal oscillator, this is a few to several dozen ms; for a ceramic oscillator, this is several hundred  $\mu\text{s}$  to a few ms, and for an external clock this is 0 ms.

- In normal operation

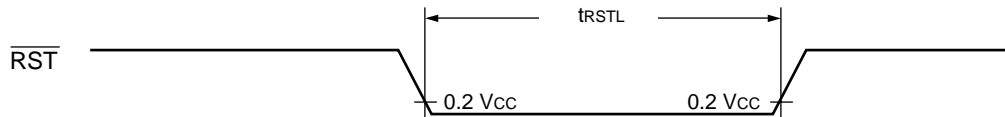

- In stop mode

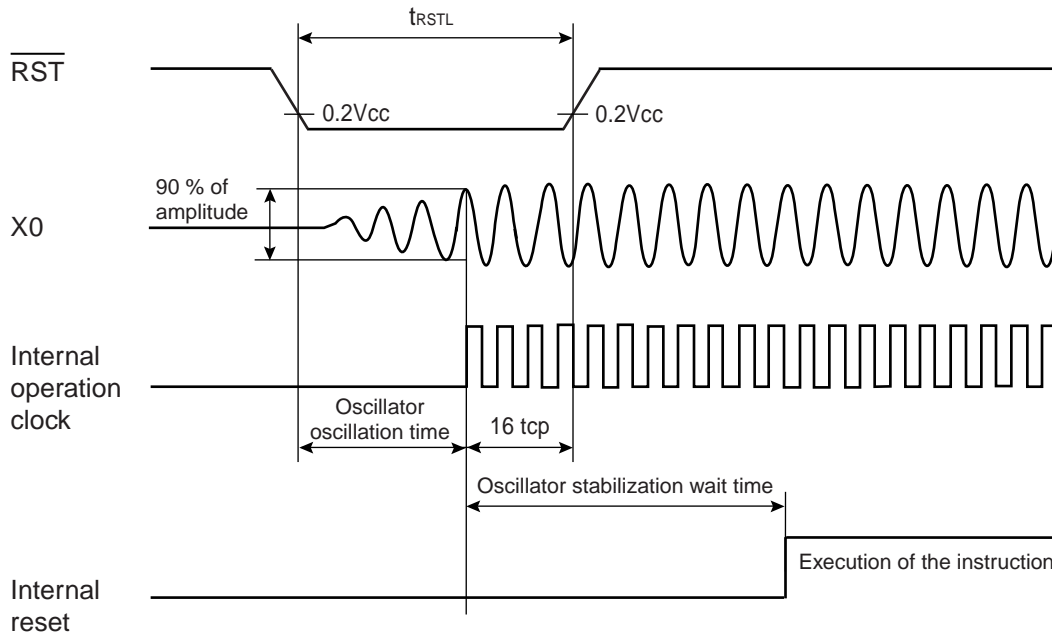

## (3) Power-On Reset

( $T_A = -40\text{ }^{\circ}\text{C}$  to  $+85\text{ }^{\circ}\text{C}$ ,  $V_{CC} = 2.7\text{ V}$  to  $3.6\text{ V}$ ,  $V_{SS} = AV_{SS} = 0.0\text{ V}$ )

Parameter	Symbol	Pin Name	Condition	Value		Unit	Remarks
				Min.	Max.		
Power supply rise time	$t_R$	$V_{CC}^*$	—	0.05	30	ms	
Power supply cutoff time	$t_{OFF}$	$V_{CC}$	—	4	—	ms	For repeated operation

\* :  $V_{CC}$  must be less than 0.2 V before power-on.

- Notes :
- The above rating values are for generating a power-on reset.
  - Some internal registers are only initialized by a power-on reset. Always apply the power supply in accordance with the above ratings if you wish to initialize these registers.

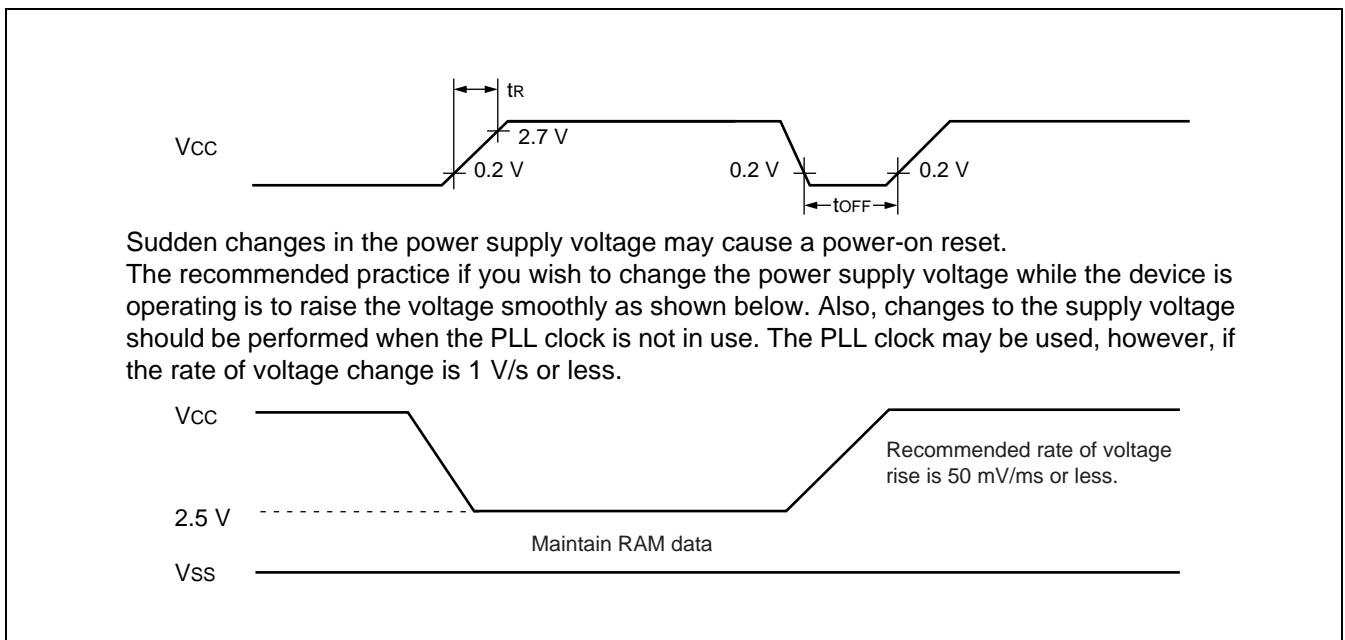

# MB90560/565 Series

## (4) UART0 and UART1

( $T_A = -40\text{ }^{\circ}\text{C}$  to  $+85\text{ }^{\circ}\text{C}$ ,  $V_{CC} = 2.7\text{ V}$  to  $3.6\text{ V}$ ,  $V_{SS} = AV_{SS} = 0.0\text{ V}$ )

Parameter	Symbol	Pin Name	Condition	Value		Unit	Remarks
				Min.	Max.		
Serial clock cycle time	$t_{SCYC}$	SCK0, SCK1	Internal shift clock mode, output pin load is $C_L = 80\text{ pF} + 1\text{ TTL}$	$8 t_{CP}$	—	ns	
SCK ↓ → SOT delay time	$t_{SLOV}$	SCK0, SCK1 SOT0, SOT1		-80	80	ns	
Valid SIN → SCK ↑	$t_{VSH}$	SCK0, SCK1 SIN0, SIN1		100	—	ns	
SCK ↑ → valid SIN hold time	$t_{SHIX}$	SCK0, SCK1 SIN0, SIN1		60	—	ns	
Serial clock "H" pulse width	$t_{SHSL}$	SCK0, SCK1	External shift clock mode, output pin load is $C_L = 80\text{ pF} + 1\text{ TTL}$	$4 t_{CP}$	—	ns	
Serial clock "L" pulse width	$t_{SLSH}$	SCK0, SCK1		$4 t_{CP}$	—	ns	
SCK ↓ → SOT delay time	$t_{SLOV}$	SCK0, SCK1 SOT0, SOT1		—	150	ns	
Valid SIN → SCK ↑	$t_{VSH}$	SCK0, SCK1 SIN0, SIN1		60	—	ns	
SCK ↑ → valid SIN hold time	$t_{SHIX}$	SCK0, SCK1 SIN0, SIN1		60	—	ns	

- Notes :
- These are the AC ratings for CLK synchronous mode.
  - CV is the load capacitor connected to the pin for testing.
  - $t_{CP}$  is the machine cycle period (unit = ns)

• Internal shift clock mode

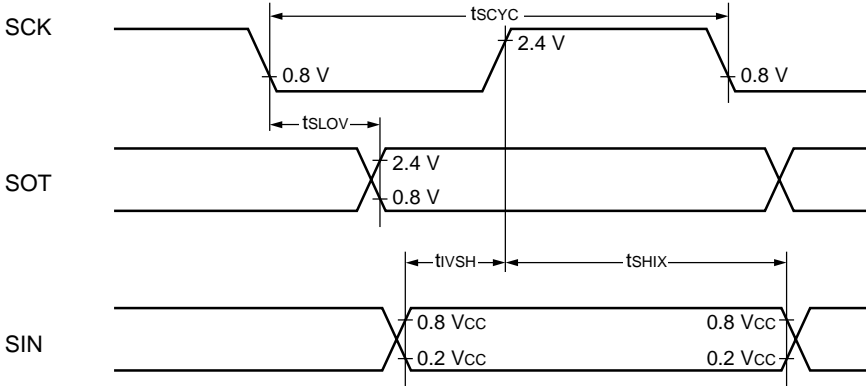

• External shift clock mode

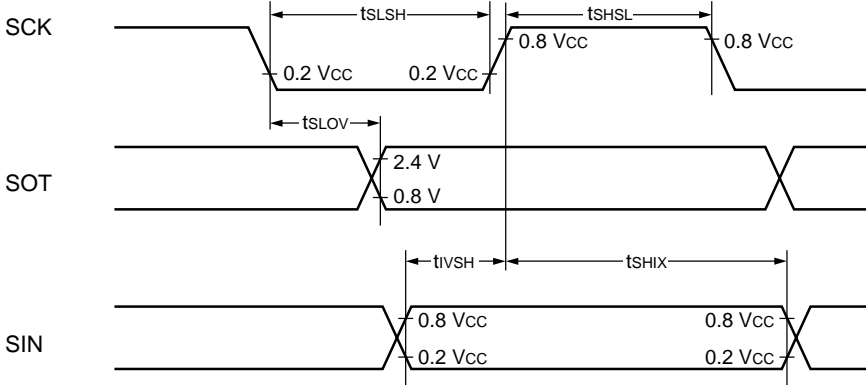

# MB90560/565 Series

## (5) Timer Input Timings

( $T_A = -40\text{ }^\circ\text{C}$  to  $+85\text{ }^\circ\text{C}$ ,  $V_{CC} = 2.7\text{ V}$  to  $3.6\text{ V}$ ,  $V_{SS} = AV_{SS} = 0.0\text{ V}$ )

Parameter	Symbol	Pin Name	Condition	Value		Unit	Remarks
				Min.	Max.		
Input pulse width	$t_{TIWH}$ , $t_{TIWL}$	FRCK, TIN0, TIN1	—	$4 t_{CP}$	—	ns	

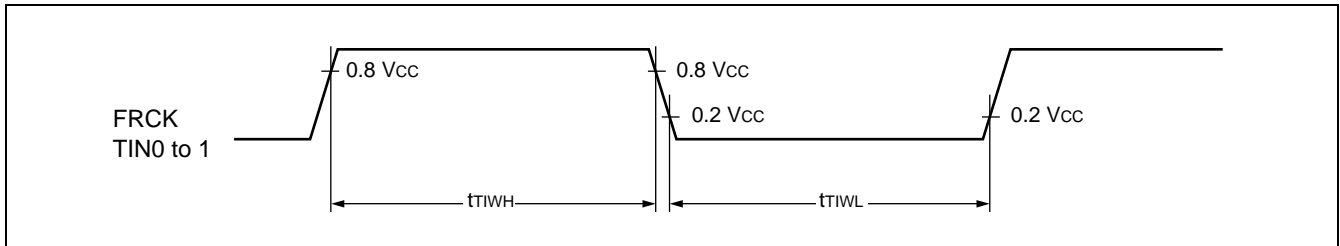

## (6) Timer Output Timings

( $T_A = -40\text{ }^\circ\text{C}$  to  $+85\text{ }^\circ\text{C}$ ,  $V_{CC} = 2.7\text{ V}$  to  $3.6\text{ V}$ ,  $V_{SS} = AV_{SS} = 0.0\text{ V}$ )

Parameter	Symbol	Pin Name	Condition	Value		Unit	Remarks
				Min.	Max.		
CLK $\uparrow$ $\rightarrow$ T <sub>OUT</sub> change time	$t_{TO}$	RTO0 to RTO5, PPG0 to PPG5 TO0, TO1	—	30	—	ns	

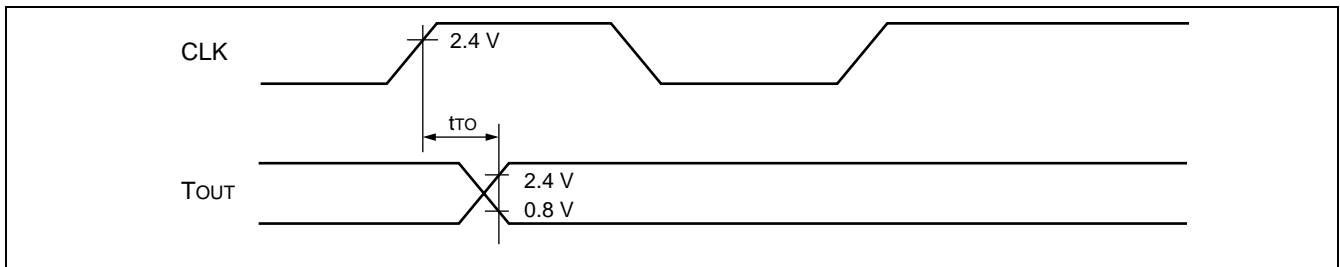

## (7) Trigger Input Timings

( $T_A = -40\text{ }^\circ\text{C}$  to  $+85\text{ }^\circ\text{C}$ ,  $V_{CC} = 2.7\text{ V}$  to  $3.6\text{ V}$ ,  $V_{SS} = AV_{SS} = 0.0\text{ V}$ )

Parameter	Symbol	Pin Name	Condition	Value		Unit	Remarks
				Min.	Max.		
Input pulse width	$t_{TRGL}$	INT0 to INT7, IN0 to IN3	—	$5 t_{CP}$	—	ns	In normal operation
				1	—	$\mu\text{s}$	In stop mode

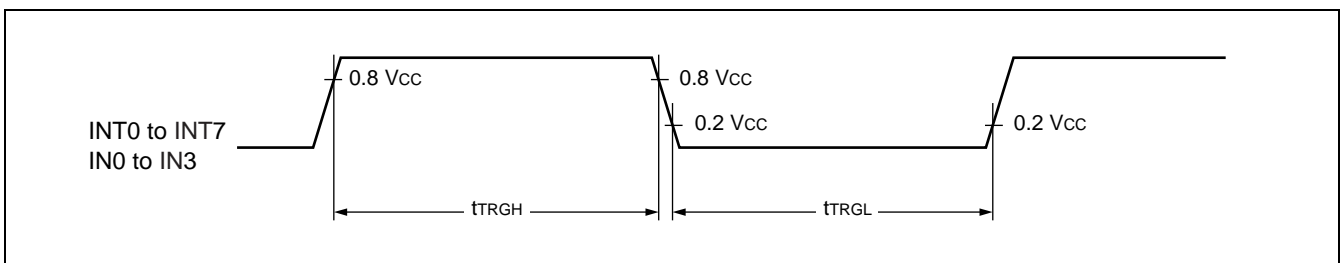

## 5. Electrical Characteristics for the A/D Converter

(MB90567/568/F568 :  $T_A = -40\text{ }^\circ\text{C}$  to  $+85\text{ }^\circ\text{C}$ ,  $2.7\text{ V} \leq \text{AVR}$ ,  $V_{CC} = \text{AV}_{CC} = 2.7\text{ V}$  to  $3.6\text{ V}$ ,  $V_{SS} = \text{AV}_{SS} = 0.0\text{ V}$ )

(MB90V560 :  $T_A = +25\text{ }^\circ\text{C}$ ,  $3.0\text{ V} \leq \text{AVR}$ ,  $V_{CC} = \text{AV}_{CC} = 3.0\text{ V}$  to  $3.6\text{ V}$ ,  $V_{SS} = \text{AV}_{SS} = 0.0\text{ V}$ )

Parameter	Symbol	Pin Name	Value			Unit	Remarks
			Min.	Typ.	Max.		
Resolution	—	—	—	—	10	bit	
Total error	—	—	—	—	$\pm 3.0$	LSB	
Non-linearity error	—	—	—	—	$\pm 2.5$	LSB	
Differential linearity error	—	—	—	—	$\pm 1.9$	LSB	
Zero transition voltage	$V_{OT}$	AN0 to AN7	$\text{AV}_{SS}$ -1.5 LSB	$\text{AV}_{SS}$ +0.5 LSB	$\text{AV}_{SS}$ +2.5 LSB	V	1 LSB = $(\text{AVR} - \text{AV}_{SS}) / 1024$
Full-scale transition voltage	$V_{FST}$	AN0 to AN7	$\text{AVR}$ -3.5 LSB	$\text{AVR}$ -1.5 LSB	$\text{AVR}$ +0.5 LSB	V	
Conversion time	—	—	—	66 $t_{CP}$	—	ns	
Sampling time	—	—	—	32 $t_{CP}$	—	ns	
Analog port input current	$I_{AIN}$	AN0 to AN7	—	—	10	$\mu\text{A}$	
Analog input voltage	$V_{AIN}$	AN0 to AN7	0	—	AVR	V	
Reference voltage	—	AVR	2.7	—	$\text{AV}_{CC}$	V	
Power supply current	$I_A$	$\text{AV}_{CC}$	—	1	5	mA	
	$I_{AH}$	$\text{AV}_{CC}$	—	—	5	$\mu\text{A}$	*
Reference voltage supply current	$I_R$	AVR	—	100	200	$\mu\text{A}$	
	$I_{RH}$	AVR	—	—	5	$\mu\text{A}$	*
Variation between channels	—	AN0 to AN7	—	—	4	LSB	

\* : Current when A/D converter is not used and CPU is in stop mode ( $V_{CC} = \text{AV}_{CC} = \text{AVR} = 3.3\text{ V}$ )

Notes : • The L reference voltage is fixed to  $\text{AV}_{SS}$ . The relative error increases as AVR becomes smaller.

- Ensure that the output impedance of the external circuit connected to the analog input meets the following condition :

Output impedance of MB90F568 external circuit  $\leq 14\text{ k}\Omega$  (Sampling Time =  $4\text{ }\mu\text{s}$ )

Output impedance of MB90567/568 external circuit  $\leq 7\text{ k}\Omega$  (Sampling Time =  $4\text{ }\mu\text{s}$ )

- If the output impedance of the external circuit is too high, the analog voltage sampling time may be too short.

# MB90560/565 Series

- Equivalent circuit of analog input circuit

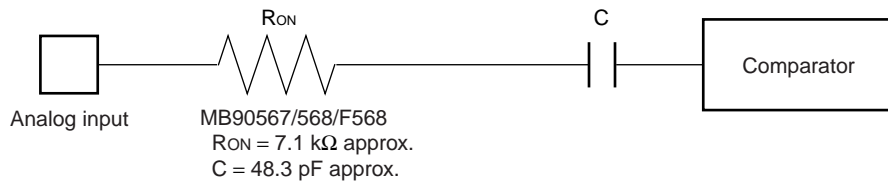

Note : The values listed are an indication only.

## 6. Flash Memory Erase and Programming Performance

Parameter	Condition	Value			Units	Remarks
		Min	Typ	Max		
Sector erase time	T <sub>A</sub> = + 25 °C V <sub>CC</sub> = 3.3 V	—	1	15	s	Excludes 00H programming prior erasure
Chip erase time		—	5	—	s	Excludes 00H programming prior erasure
Word (16 bit width) programming time		—	16	3,600	μs	Excludes system-level overhead
Erase/Program cycle	—	10,000	—	—	cycle	
Data holding time	—	100,000	—	—	h	

### • Points to note regarding the MB90F568, 567, and 568 specifications

This section describes the specification differences between the MB90F568/567/568 and the MB90F562B/562A/561A.

#### (1) Functional differences

- 1) The 5 V to 3 V regulator has been removed in the MB96565 series.  
The C pin has been changed to an N.C. pin.
- 2) The A/D converter unit in the MB96565 series has changed from a 5 V version to a 3 V version.  
However, the conversion time and sampling time remain the same.
- 3) The maximum voltage that can be applied to I/O pins has changed from 5 V to 3 V in the MB96565 series.
- 4) Added transfer counter clear function to UART in the MB96565 series.  
This function restores the UART to its initial state when “0” is written to the UART reset bit.

#### (2) Points to note when using the devices

The MB90F562B, and F568 use P60 (14) as SIN1, P61 (15) as SOT1, and P40 (60) as SCK0 when performing on-board programming.

Use the following pin settings when performing on-board programming.

Pin Name	Pin I/O Level*	Remarks
MD2	“H” level	Serial write mode settings
MD1	“H” level	
MD0	“L” level	
SIN1	Serial data input	Normally shared with P60
SOT1	Serial data output	Normally shared with P61
SCK0	Serial clock	Normally shared with P40
P00	“L” level	
P01	“H” level	Input “L” level for PC writing

\* : These settings are for using a Yokogawa Digital Computer Corporation writer for on-board programming. Alternatively, writing can be performed from a PC, but a special write program is required.

# MB90560/565 Series

## EXAMPLE CHARACTERISTICS

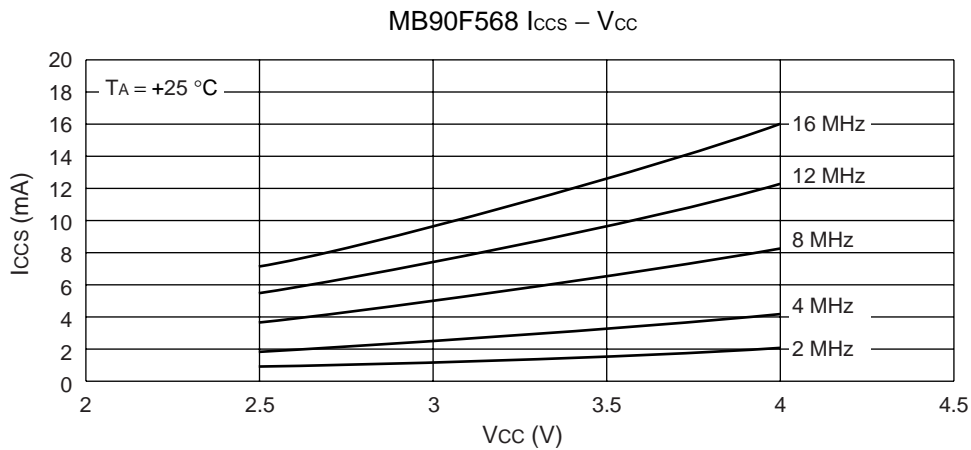
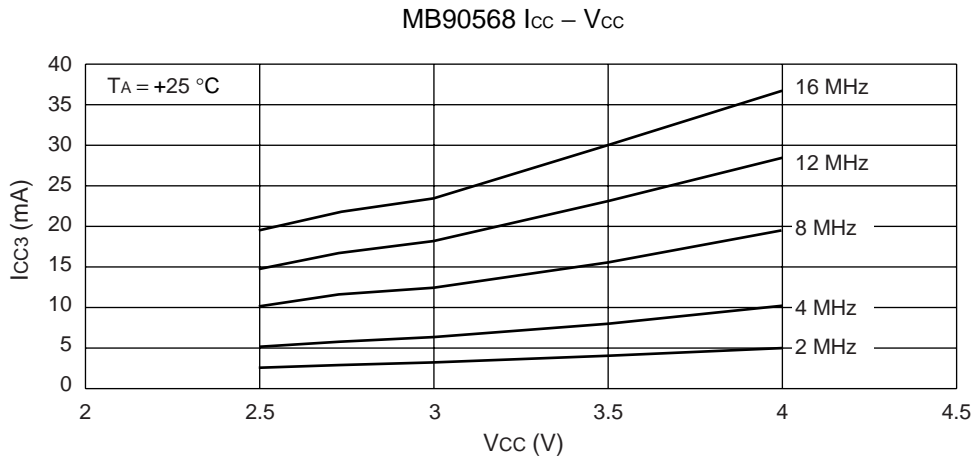
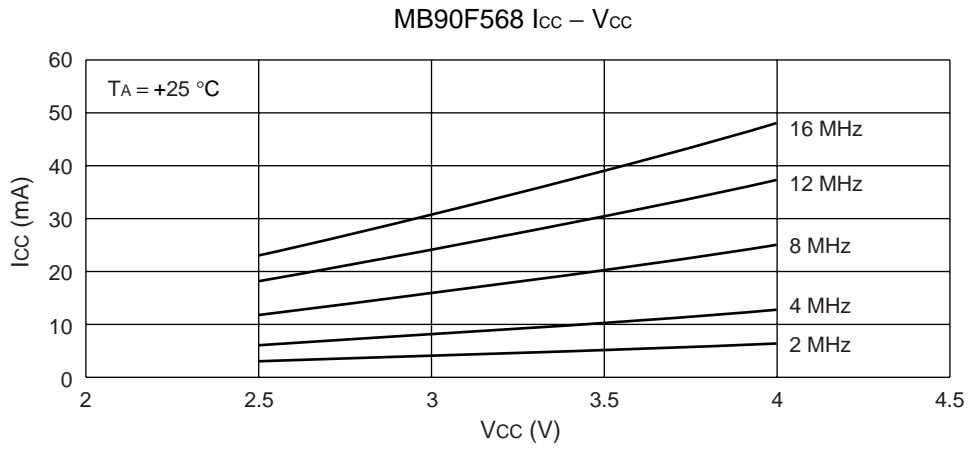

(Continued)

MB90568  $I_{CCS} - V_{CC}$

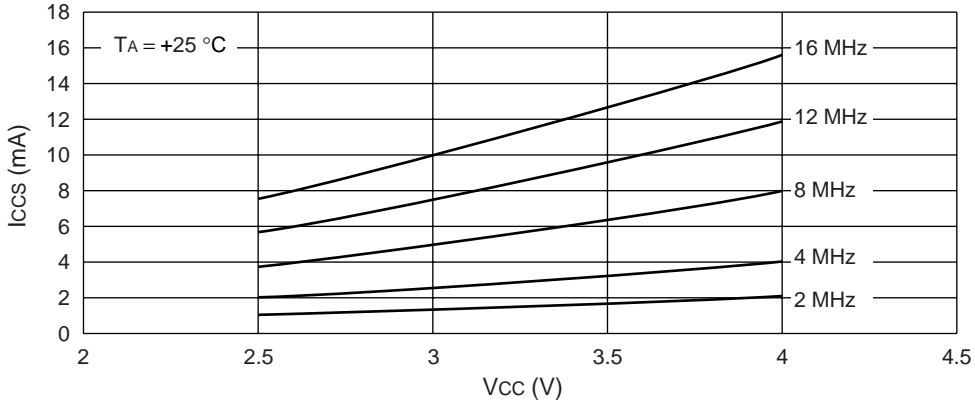

MB90F562  $I_{CC} - V_{CC}$

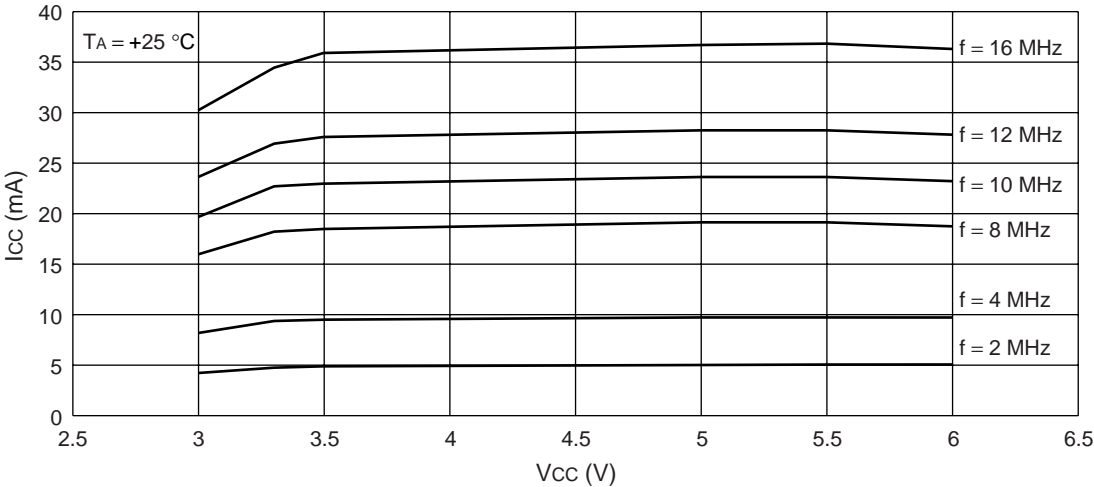

MB90562  $I_{CC} - V_{CC}$

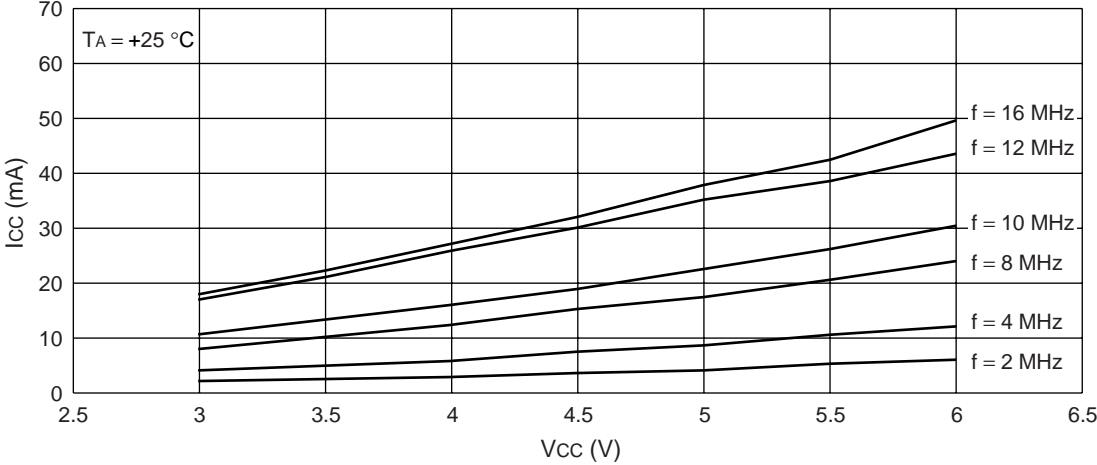

(Continued)

# MB90560/565 Series

(Continued)

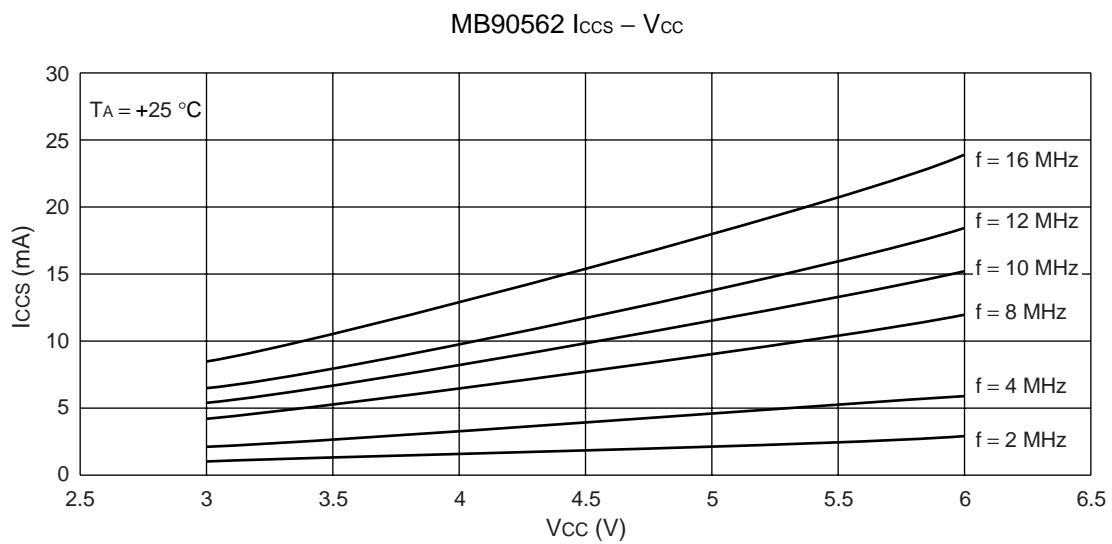
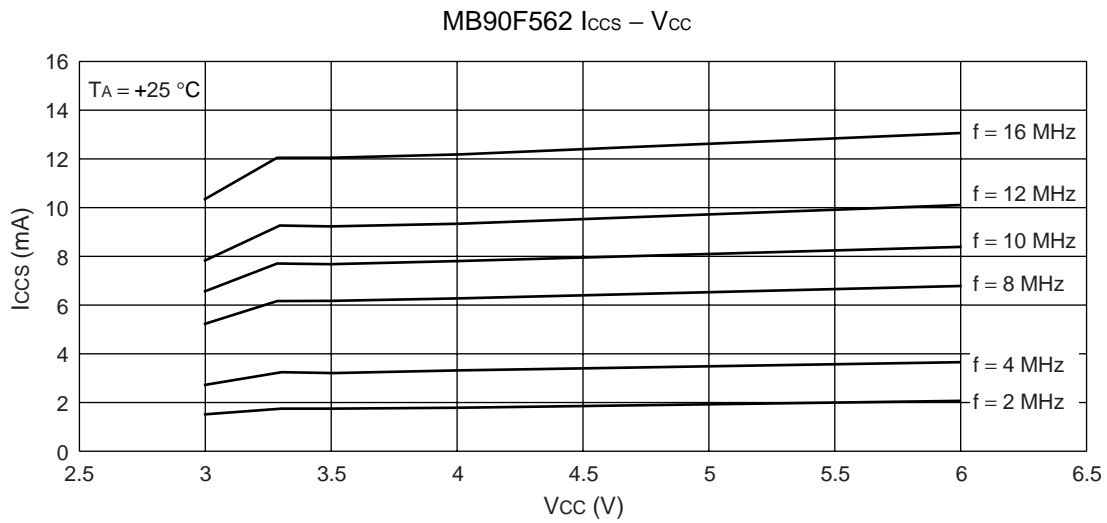

# MB90560/565 Series

## ■ ORDERING INFORMATION

### • MB90560 series

Part No.	Package	Remarks
MB90561AP MB90562AP MB90F562BP	64-pin plastic SH-DIP (DIP-64P-M01)	
MB90561APF MB90562APF MB90F562BPF	64-pin plastic QFP (FPT-64P-M06)	
MB90561APMC MB90562APMC MB90F562BPMC	64-pin plastic LQFP (FPT-64P-M23)	

### • MB90565 series

Part No.	Package	Remarks
MB90567PF MB90568PF MB90F568PF	64-pin plastic QFP (FPT-64P-M06)	
MB90567PMC MB90568PMC MB90F568PMC	64-pin plastic LQFP (FPT-64P-M23)	

# MB90560/565 Series

## PACKAGE DIMENSIONS

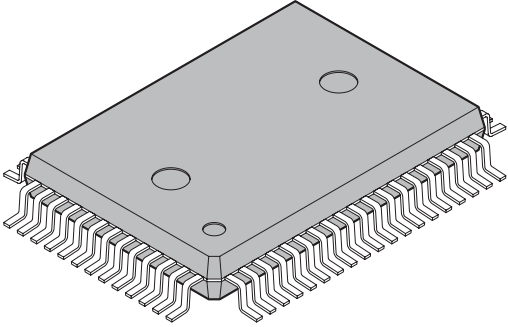
<p>64-pin plastic QFP</p>  <p>(FPT-64P-M06)</p>	Lead pitch	1.00 mm
	Package width × package length	14 × 20 mm
	Lead shape	Gullwing
	Sealing method	Plastic mold
	Mounting height	3.35 mm MAX
	Code (Reference)	P-QFP64-14×20-1.00

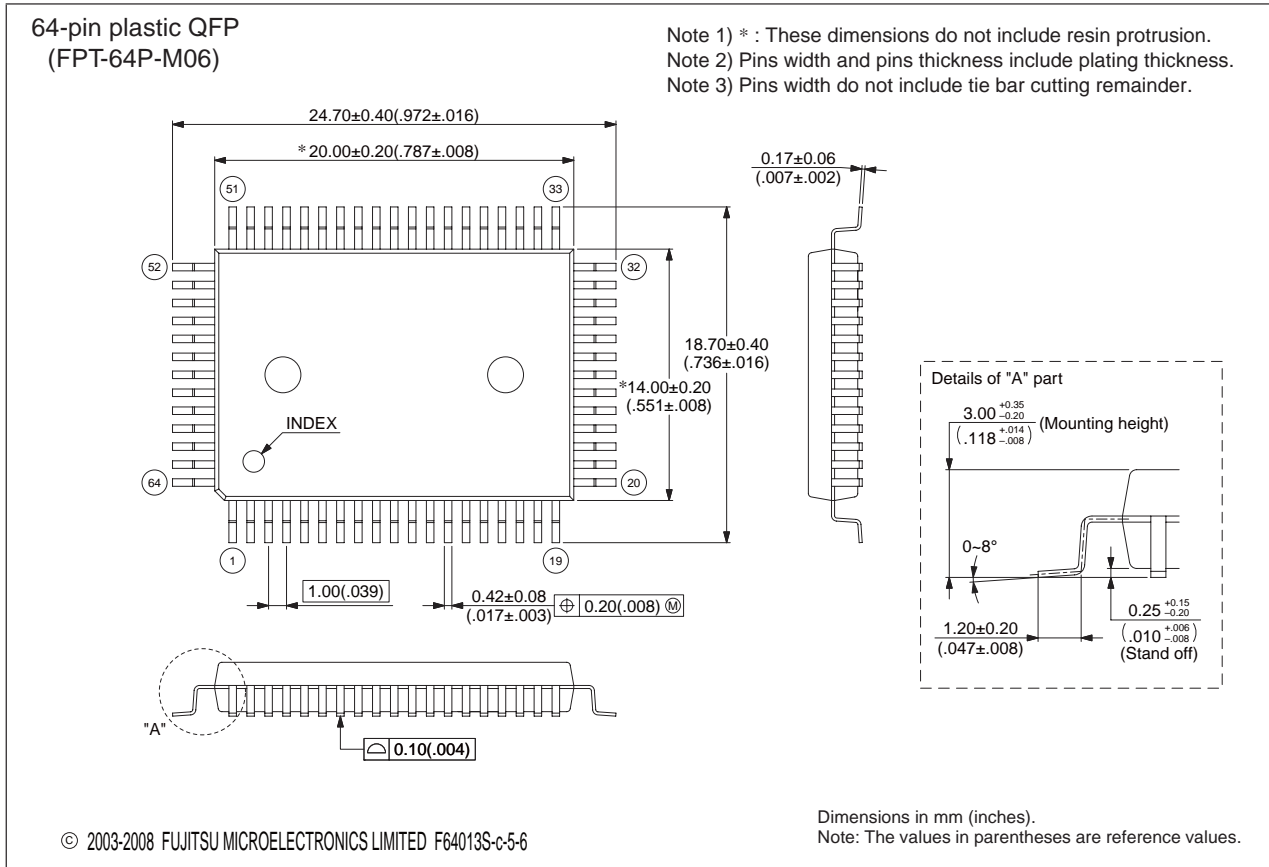

Please confirm the latest Package dimension by following URL.  
<http://edevic.fujitsu.com/package/en-search/>

(Continued)

# MB90560/565 Series

(Continued)

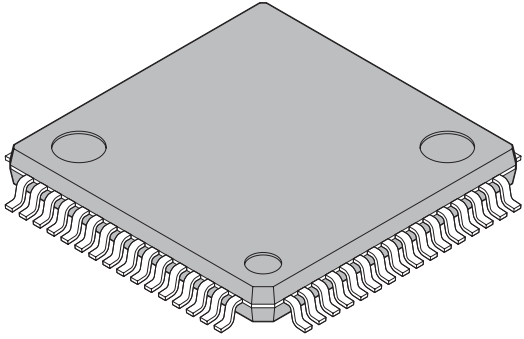
<p style="text-align: center;">64-pin plastic LQFP</p>  <p style="text-align: center;">(FPT-64P-M23)</p>	Lead pitch	0.65 mm
	Package width × package length	12.0 × 12.0 mm
	Lead shape	Gullwing
	Sealing method	Plastic mold
	Mounting height	1.70 mm MAX
	Code (Reference)	P-LFQFP64-12×12-0.65

64-pin plastic LQFP  
(FPT-64P-M23)

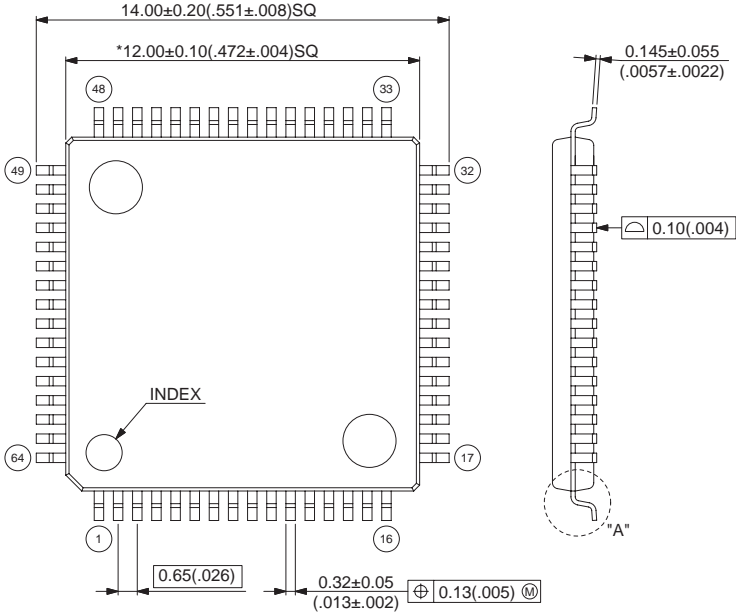

©2003-2008 FUJITSU MICROELECTRONICS LIMITED F64034S-c-1-2

Note 1) \* : These dimensions do not include resin protrusion.  
 Note 2) Pins width and pins thickness include plating thickness.  
 Note 3) Pins width do not include tie bar cutting remainder.

Details of "A" part

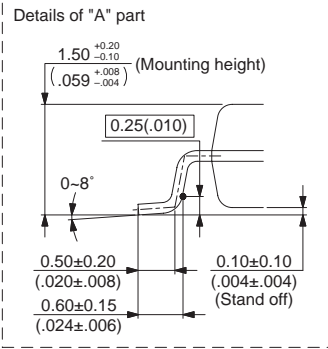

Dimensions in mm (inches).  
 Note: The values in parentheses are reference values

Please confirm the latest Package dimension by following URL.  
<http://edevice.fujitsu.com/package/en-search/>

# MB90560/565 Series

## ■ MAIN CHANGES IN THIS EDITION

Page	Section	Change Results
—	—	Deleted the description of old products MB90561, MB90562, and MB90F562.
—	—	The package code is changed. (FPT-64P-M09 → FPT-64P-M23)
34	■ PERIPHERAL FUNCTIONS 3. Watchdog Timer	The resource name of watch timer is collected. (clock timer → watch timer)
55	■ PERIPHERAL FUNCTIONS 13. 1 Mbit Flash Memory	Deleted “. Standard configuration for Fujitsu Microelectronics standard serial on-board programming”.
66	■ ELECTRICAL CHARACTERISTICS (MB90560 SERIES) 5. Electrical Characteristics for the A/D Converter	Changed the items of “Zero transition voltage” and “Full-scale transition voltage”.
79	■ ELECTRICAL CHARACTERISTICS (MB90565 SERIES) 5. Electrical Characteristics for the A/D Converter	Changed the items of “Zero transition voltage” and “Full-scale transition voltage”.
85	■ ORDERING INFORMATION	Order informations are changed. (MB90561APFM → MB90561APMC MB90562APFM → MB90562APMC MB90F562BPFM → MB90F562BPMC MB90567PFM → MB90567PMC MB90568PFM → MB90568PMC MB90F568PFM → MB90F568PMC)
87	■ PACKAGE DIMENSIONS	The package figure is changed. (FPT-64P-M09 → FPT-64P-M23)

The vertical lines marked in the left side of the page show the changes.

**MEMO**

**MEMO**

**MEMO**

# MB90560/565 Series

## FUJITSU MICROELECTRONICS LIMITED

7-1, Nishishinjuku 2-chome, Shinjuku Dai-Ichi Seimei Bldg.,

Shinjuku-ku, Tokyo 163-0722, JAPAN

Tel: +81-3-5322-3347 Fax: +81-3-5322-3387

<http://jp.fujitsu.com/fml/en/>

*For further information please contact:*

### North and South America

FUJITSU MICROELECTRONICS AMERICA, INC.

1250 E. Arques Avenue, M/S 333

Sunnyvale, CA 94085-5401, U.S.A.

Tel: +1-408-737-5600 Fax: +1-408-737-5999

<http://www.fma.fujitsu.com/>

### Asia Pacific

FUJITSU MICROELECTRONICS ASIA PTE LTD.

151 Lorong Chuan, #05-08 New Tech Park,

Singapore 556741, SINGAPORE

Tel: +65-6281-0770 Fax: +65-6281-0220

<http://www.fujitsu.com/sg/services/micro/semiconductor/>

### Europe

FUJITSU MICROELECTRONICS EUROPE GmbH

Pittlerstrasse 47, 63225 Langen, F. R. GERMANY

Tel: +49-6103-690-0 Fax: +49-6103-690-122

<http://emea.fujitsu.com/microelectronics/>

FUJITSU MICROELECTRONICS SHANGHAI CO., LTD.

No.222 Yan An Road(E), Rm.3102, Bund Center,

Shanghai 200002, P. R. CHINA

Tel: +86-21-6335-1560 Fax: +86-21-6335-1605

<http://cn.fujitsu.com/fmc/>

### Korea

FUJITSU MICROELECTRONICS KOREA LTD.

1002 Daechi-Dong, 206 KOSMO TOWER,

Kangnam-Gu, Seoul 135-280, KOREA

Tel: +82-2-3484-7100 Fax: +82-2-3484-7111

<http://www.fmk.fujitsu.com/>

FUJITSU MICROELECTRONICS PACIFIC ASIA LTD.

11 Canton Road, 10/F., World Commerce Centre,

Tsimshatsui, Kowloon, HONG KONG

Tel: +852-2377-0226 Fax: +852-2376-3269

<http://cn.fujitsu.com/fmc/tw>

All Rights Reserved.

The contents of this document are subject to change without notice.

Customers are advised to consult with sales representatives before ordering.

The information, such as descriptions of function and application circuit examples, in this document are presented solely for the purpose of reference to show examples of operations and uses of FUJITSU MICROELECTRONICS device; FUJITSU MICROELECTRONICS does not warrant proper operation of the device with respect to use based on such information. When you develop equipment incorporating the device based on such information, you must assume any responsibility arising out of such use of the information.

FUJITSU MICROELECTRONICS assumes no liability for any damages whatsoever arising out of the use of the information.

Any information in this document, including descriptions of function and schematic diagrams, shall not be construed as license of the use or exercise of any intellectual property right, such as patent right or copyright, or any other right of FUJITSU MICROELECTRONICS or any third party or does FUJITSU MICROELECTRONICS warrant non-infringement of any third-party's intellectual property right or other right by using such information. FUJITSU MICROELECTRONICS assumes no liability for any infringement of the intellectual property rights or other rights of third parties which would result from the use of information contained herein.

The products described in this document are designed, developed and manufactured as contemplated for general use, including without limitation, ordinary industrial use, general office use, personal use, and household use, but are not designed, developed and manufactured as contemplated (1) for use accompanying fatal risks or dangers that, unless extremely high safety is secured, could have a serious effect to the public, and could lead directly to death, personal injury, severe physical damage or other loss (i.e., nuclear reaction control in nuclear facility, aircraft flight control, air traffic control, mass transport control, medical life support system, missile launch control in weapon system), or (2) for use requiring extremely high reliability (i.e., submersible repeater and artificial satellite).

Please note that FUJITSU MICROELECTRONICS will not be liable against you and/or any third party for any claims or damages arising in connection with above-mentioned uses of the products.

Any semiconductor devices have an inherent chance of failure. You must protect against injury, damage or loss from such failures by incorporating safety design measures into your facility and equipment such as redundancy, fire protection, and prevention of over-current levels and other abnormal operating conditions.

Exportation/release of any products described in this document may require necessary procedures in accordance with the regulations of the Foreign Exchange and Foreign Trade Control Law of Japan and/or US export control laws.

The company names and brand names herein are the trademarks or registered trademarks of their respective owners.