

16-Bit Original Microcontroller

CMOS

F²MC-16LX MB90420G/425G Series

**MB90423GA/423GC/F423GA/F423GC/427GA/427GC/428GA/428GC/
MB90F428GA/F428GC/V420G**

■ DESCRIPTIONS

The FUJITSU MICROELECTRONICS MB90420G/425G Series is a 16-bit general purpose high-capacity microcontroller designed for vehicle meter control applications etc.

The instruction set retains the same AT architecture as the FUJITSU MICROELECTRONICS original F²MC-8L and F²MC-16L series, with further refinements including high-level language instructions, expanded addressing mode, enhanced (signed) multiplier-divider computation and bit processing.

In addition, a 32-bit accumulator is built in to enable long word processing.

■ FEATURES

- 16-bit input capture (4 channels)
Detects rising, falling, or both edges.
16-bit capture register × 4
Pin input edge detection latches the 16-bit free-run timer counter value, and generates an interrupt request.
- 16-bit reload timer (2 channels)
16-bit reload timer operation (select toggle output or one-shot output)
Event count function selection provided
- Watch timer (main clock)
Operates directly from oscillator clock.
Compensates for oscillator deviation
Read/write enabled second/minute/hour register
Signal interrupt

(Continued)

The information for microcontroller supports is shown in the following homepage.
Be sure to refer to the "Check Sheet" for the latest cautions on development.

"Check Sheet" is seen at the following support page

"Check Sheet" lists the minimal requirement items to be checked to prevent problems beforehand in system development.

<http://edevice.fujitsu.com/micom/en-support/>

MB90420G/425G Series

- 16-bit PPG (3 channels)
Output pins (3) , external trigger input pin (1)
Output clock frequencies : f_{CP} , $f_{CP}/2^2$, $f_{CP}/2^4$, $f_{CP}/2^6$
- Delay interrupt
Generates interrupt for task switching.
Interruptions to CPU can be generated/deleted by software setting.
- External interrupts (8 channels)
8-channel independent operation
Interrupt source setting available : “L” to “H” edge/ “H” to “L” edge/ “L” level/ “H” level.
- A/D converter
10-bit or 8-bit resolution \times 8 channels (input multiplexed)
Conversion time : 6.13 μ s or less (at $f_{CP} = 16$ MHz)
External trigger startup available (P50/INT0/ADTG)
Internal timer startup available (16-bit reload timer 1)
- UART (2 channels)
Full duplex double buffer type
Supports asynchronous/synchronous transfer (with start/stop bits)
Internal timer can be selected as clock (16-bit reload timer 0)
Asynchronous : 4808 bps, 5208 bps, 9615 bps, 10417 bps, 19230 bps, 38460 bps, 62500 bps, 500000 bps
Synchronous : 500 Kbps, 1Mbps, 2Mbps (at $f_{CP} = 16$ MHz)
- CAN interface *1
Conforms to CAN specifications version 2.0 Part A and B.
Automatic resend in case of error.
Automatic transfer in response to remote frame.
16 prioritized message buffers for data and messages for data and ID
Multiple message support
Receiving filter has flexible configuration : All bit compare/all bit mask/two partial bit masks
Supports up to 1 Mbps
CAN WAKEUP function (connects RX internally to INT0)
- LCD controller/driver (1 channel)
Segment driver and command driver with direct LCD panel (display) drive capability
- Low voltage/Program Looping detect reset *2
Automatic reset when low voltage is detected
Program Looping detection function
- Stepping motor controller (4 channels)
High current output for all channels \times 4
Synchronized 8/10-bit PWM for all channels \times 2
- Sound generator
8-bit PWM signal mixed with tone frequency from 8-bit reload counter.
PWM frequencies : 62.5 kHz, 31.2 kHz, 15.6 kHz, 7.8 kHz (at $f_{CP} = 16$ MHz)
Tone frequencies : 1/2 PWM frequency, divided by (reload frequency +1)
- Input/output ports
Push-pull output and Schmitt trigger input
Programmable in bit units for input/output or peripheral signals.

(Continued)

(Continued)

- Flash memory

Supports automatic programming, Embedded Algorithm™, write/erase/erase pause/erase resume instructions

Flag indicates algorithm completion

Minato Electronics flash writer

Boot block configuration

Erasable by blocks

Block protection by external programming voltage

*1 : MB90420G series has 2 channels built-in, MB90425G series has 1 channel built-in

*2 : Built-in to MB90420GA/425GA series only. Not built-in to MB90420GC/425GC series.
Embedded Algorithm is a registered trademark of Advanced Micro Devices Inc.

MB90420G/425G Series

■ PRODUCT LINEUP

• MB90420G Series

Part number	MB90F423GA	MB90F423GC	MB90423GA	MB90423GC	MB90V420G
Parameter					
Configuration	Flash ROM model		Mask ROM model		Evaluation model
CPU	F ² MC-16LX CPU				
Clock	1 system	2 systems	1 system	2 systems	2 systems
System clock	On-chip PLL clock multiplier type (× 1, × 2, × 3, × 4, 1/2 when PLL stopped) Minimum instruction execution time 62.5 ns (with 4 MHz oscillator × 4)				
ROM	Flash ROM 128 KB		Mask ROM 128 KB		External
RAM	6 KB		6 KB		6 KB
CAN interface	2 channels				
Low voltage/ CPU operation detection reset	Yes	No	Yes	No	No
Packages	QFP100, LQFP100				PGA-256
Emulator dedicated power supply*	—				No

* : When used with emulation pod MB2145-507, use DIP switch S2 setting. For details see the MB2145-50 Hardware Manual (2.7 "Emulator Dedicated Power Supply Pin").

• MB90425G Series

Part number	MB90F428GA	MB90F428GC	MB90427GA	MB90427GC	MB90428GA	MB90428GC
Parameter						
Configuration	Flash ROM model		Mask ROM model			
CPU	F ² MC-16LX CPU					
Clock	1 system	2 systems	1 system	2 systems	1 system	2 systems
System clock	On-chip PLL clock multiplier type (× 1, × 2, × 3, × 4, 1/2 when PLL stopped) Minimum instruction execution time 62.5 ns (with 4 MHz oscillator × 4)					
ROM	Flash ROM 128 KB		Mask ROM 64 KB		Mask ROM 128 KB	
RAM	6 KB		4 KB		6 KB	
CAN interface	1 channel					
Low voltage/CPU operation detection reset	Yes	No	Yes	No	Yes	No
Packages	QFP100, LQFP100					
Emulator dedicated power supply	—					

Note : MB90V420G can be used as evaluation model for MB90420G/425G series.

MB90420G/425G Series

■ PIN ASSIGNMENTS

• QFP 100

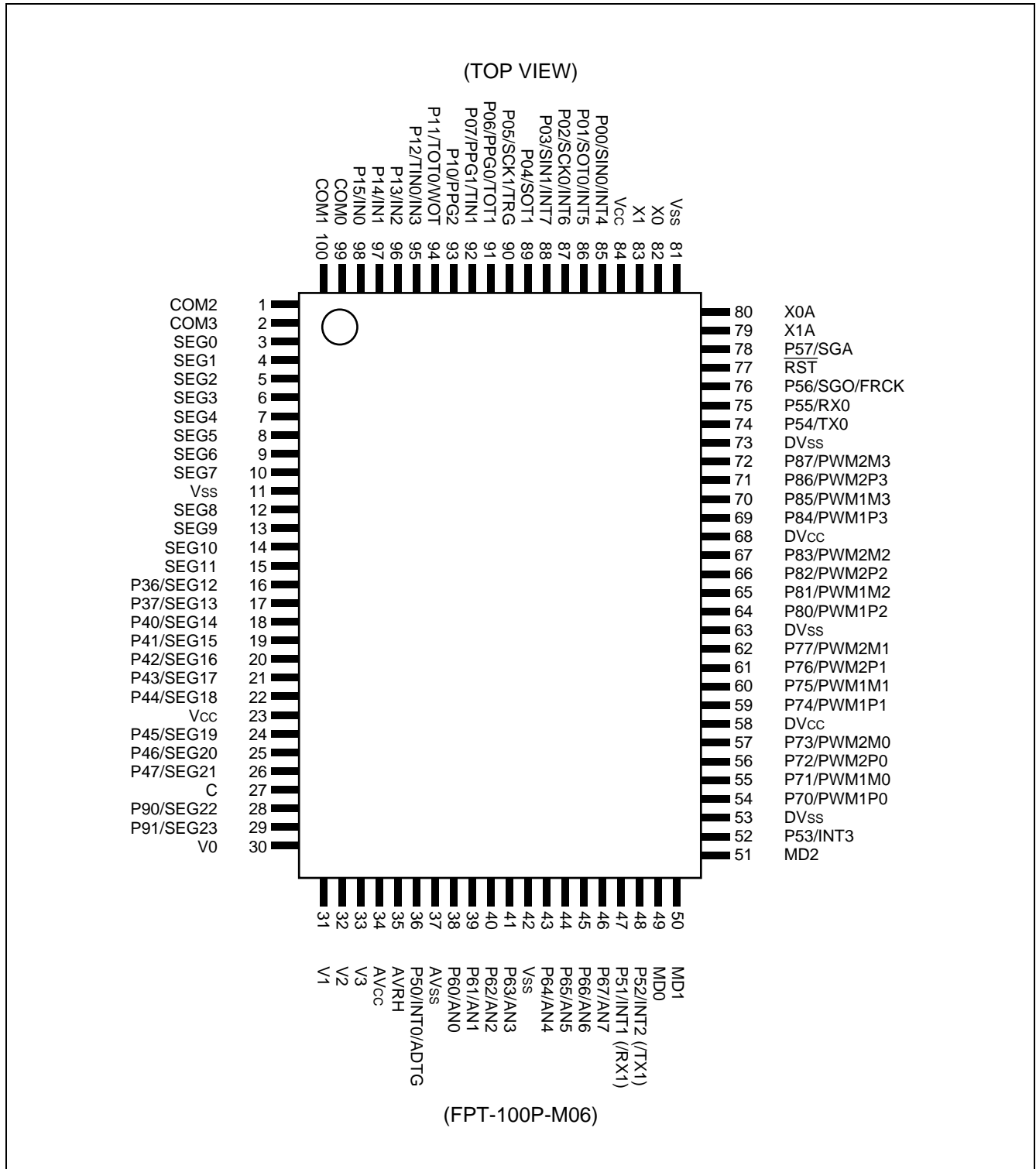

MB90420G/425G Series

• LQFP 100

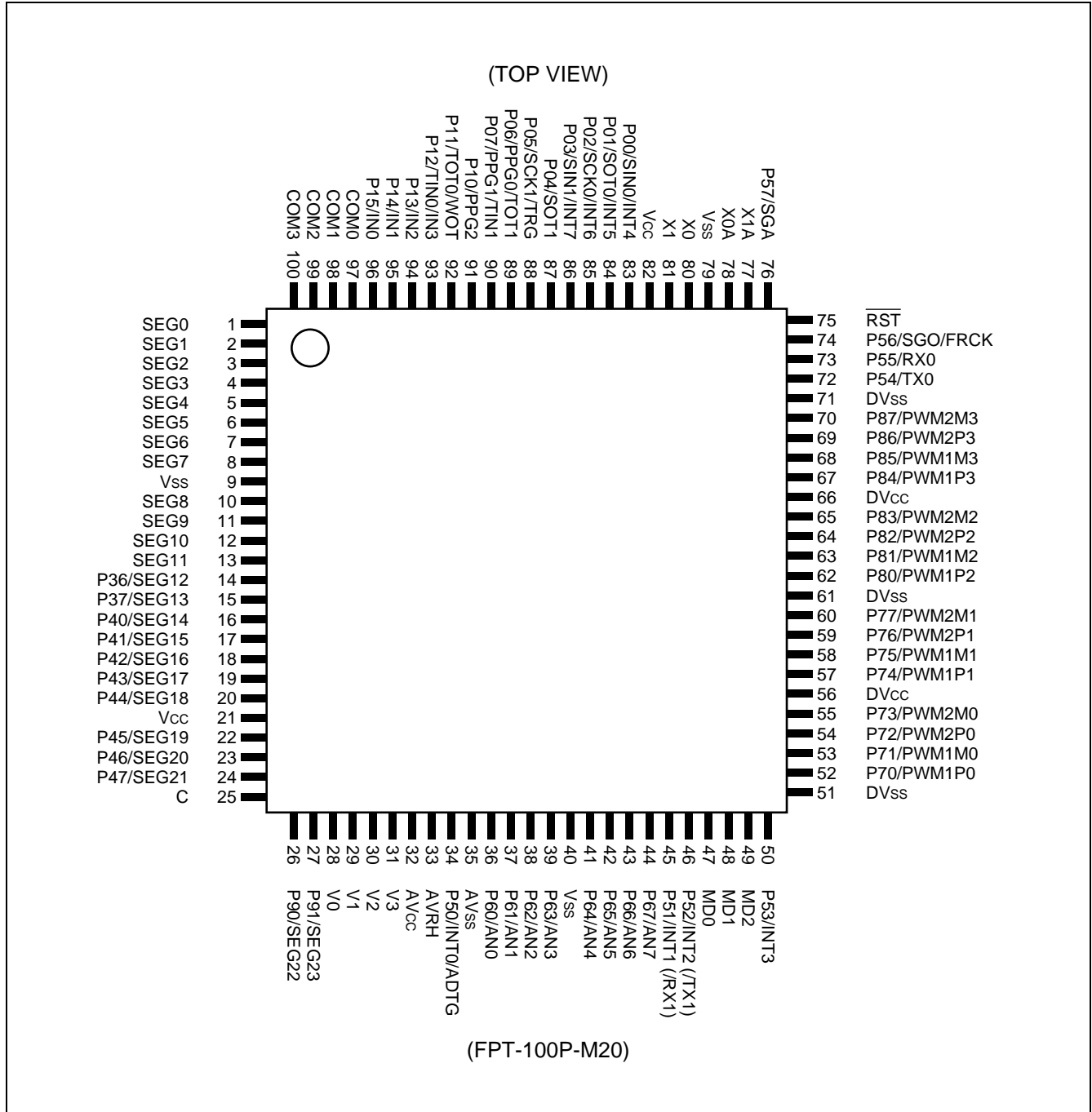

MB90420G/425G Series

■ PIN DESCRIPTIONS

Pin no.		Symbol	Circuit type	Description
LQFP	QFP			
80	82	X0	A	High speed oscillator input pin.
81	83	X1		High speed oscillator output pin.
78	80	X0A	A	Low speed oscillator input pin. If no oscillator is connected, apply pull-down processing.
77	79	X1A		Low speed oscillator output pin. If no oscillator is connected, leave open.
75	77	$\overline{\text{RST}}$	B	Reset input pin.
83	85	P00	G	General purpose input/output port.
		SIN0		UART ch.0 serial data input pin.
		INT4		INT4 external interrupt input pin.
84	86	P01	G	General purpose input/output port.
		SOT0		UART ch.0 serial data output pin.
		INT5		INT5 external interrupt input pin.
85	87	P02	G	General purpose input/output port.
		SCK0		UART ch.0 serial clock input/output pin.
		INT6		INT6 external interrupt input pin.
86	88	P03	G	General purpose input/output port.
		SIN1		UART ch.1 serial data input pin.
		INT7		INT7 external interrupt input pin.
87	89	P04	G	General purpose input/output port.
		SOT1		UART ch.1 serial data output pin.
88	90	P05	G	General purpose input/output port.
		SCK1		UART ch.1 serial clock input/output pin.
		TRG		16-bit PPG ch.0-2 external trigger input pin.
89	91	P06	G	General purpose input/output port.
		PPG0		16-bit PPG ch.0 output pin.
		TOT1		16-bit reload timer ch.1 TOT output pin.
90	92	P07	G	General purpose input/output port.
		PPG1		16-bit PPG ch.1 output pin.
		TIN1		16-bit reload timer ch.1 TIN output pin.
91	93	P10	G	General purpose input/output port.
		PPG2		16-bit PPG ch.2 output pin.

(Continued)

MB90420G/425G Series

Pin no.		Symbol	Circuit type	Description
LQFP	QFP			
92	94	P11	G	General purpose input/output port.
		TOT0		16-bit reload timer ch.0 TOT output pin.
		WOT		Real-time watch timer WOT output pin.
93	95	P12	G	General purpose input/output port.
		TIN0		16-bit reload timer ch.0 TIN output pin.
		IN3		Input capture ch.3 trigger input pin.
94 to 96	96 to 98	P13 to P15	G	General purpose input/output ports.
		IN2 to IN0		Input capture ch.0-2 trigger input pins.
97 to 100	99 to 100, 1 to 2	COM0 to COM3	I	LCD controller/driver common output pins.
1 to 8, 10 to 13	3 to 10, 12 to 15	SEG0 to SEG11	I	LCD controller/driver segment output pins.
14 to 15	16 to 17	P36 to P37	E	General purpose output ports.
		SEG12 to SEG13		LCD controller/driver segment output pins.
16 to 20, 22 to 24	18 to 22, 24 to 26	P40 to P47	E	General purpose input output ports.
		SEG14 to SEG21		LCD controller/driver segment output pins.
26, 27	28, 29	P90, P91	E	General purpose input output ports.
		SEG22, SEG23		LCD controller/driver segment output pins.
34	36	P50	G	General purpose input output ports.
		INT0		INT0 external interrupt input pin.
		ADTG		A/D converter external trigger input pin.
36 to 39, 41 to 44	38 to 41, 43 to 46	P60 to P67	F	General purpose input output ports.
		AN0 to AN7		A/D converter input pins.
45	47	P51	G	General purpose input output port.
		INT1		INT1 external interrupt input pin.
		(RX1 *1)		CAN interface 1 RX input pin.
46	48	P52	G	General purpose input output port.
		INT2		INT2 external interrupt input pin.
		(TX1 *1)		CAN interface 1 TX output pin.
50	52	P53	G	General purpose input output port.
		INT3		INT3 external interrupt input pin.

(Continued)

MB90420G/425G Series

Pin no.		Symbol	Circuit type	Description
LQFP	QFP			
52 to 55	54 to 57	P70 to P73	H	General purpose input output ports.
		PWM1P0 PWM1M0 PWM2P0 PWM2M0		Stepping motor controller ch.0 output pins.
57 to 60	59 to 62	P74 to P77	H	General purpose input output ports.
		PWM1P1 PWM1M1 PWM2P1 PWM2M1		Stepping motor controller ch.1 output pins.
62 to 65	64 to 67	P80 to P83	H	General purpose input output ports.
		PWM1P2 PWM1M2 PWM2P2 PWM2M2		Stepping motor controller ch.2 output pins.
67 to 70	69 to 72	P84 to P87	H	General purpose input output ports.
		PWM1P3 PWM1M3 PWM2P3 PWM2M3		Stepping motor controller ch.3 output pins.
72	74	P54	G	General purpose input output port.
		TX0		CAN interface 0 TX output pin.
73	75	P55	G	General purpose output port.
		RX0		CAN interface 0 RX input pin.
74	76	P56	G	General purpose input output port.
		SGO		Sound generator SGO output pin.
		FRCK		Free-run timer clock input pin.
76	78	P57	G	General purpose input output port.
		SGA		Sound generator SGA output pin.
28 to 31	30 to 33	V0 to V3	—	LCD controller /driver reference power supply pins.
56, 66	58, 68	DV _{CC}	—	High current output buffer with dedicated power supply input pins (pin numbers 54-57, 59-62, 64-67, 69-72) .
51, 61, 71	53, 63, 73	DV _{SS}	—	High current output buffer with dedicated power supply GND pins (pin numbers 54-57, 59-62, 64-67, 69-72) .
32	34	AV _{CC}	—	A/D converter dedicated power supply input pin.
35	37	AV _{SS}	—	A/D converter dedicated GND supply pin.
33	35	AVRH	—	A/D converter Vref + input pin. Vref – AV _{SS} .

(Continued)

MB90420G/425G Series

(Continued)

Pin no.		Symbol	Circuit type	Description
LQFP	QFP			
47, 48	49, 50	MD0, MD1	C	Test mode input pins. Connect to V _{CC} .
49	51	MD2	C/D *2	Text mode input pin. Connect to V _{SS} .
25	27	C	—	External capacitor pin. Connect an 0.1 μ F capacitor between this pin and V _{SS} .
21, 82	23, 84	V _{CC}	—	Power supply input pins.
9, 40, 79	11, 42, 81	V _{SS}	—	GND power supply pins.

*1 : MB90420G series only.

*2 : Type C in the flash ROM models, type D in the mask ROM models.

■ I/O CIRCUIT TYPE

Type	Circuit	Remarks
A		<ul style="list-style-type: none"> • Oscillation feedback resistance : approx. 1 MΩ (X0, X1 : MAIN) • Oscillation feedback resistance : approx. 10 MΩ (X0A, X1A : SUB)
B		<ul style="list-style-type: none"> • Pull-up resistance attached : approx. 50 kΩ, hysteresis input
C		<ul style="list-style-type: none"> • Hysteresis input
D		<ul style="list-style-type: none"> • Pull-down resistance attached : approx. 50 kΩ, hysteresis input
E		<ul style="list-style-type: none"> • CMOS output • LCDC output • Hysteresis input

(Continued)

MB90420G/425G Series

(Continued)

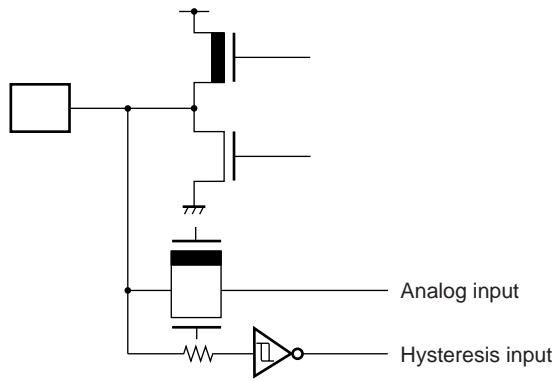
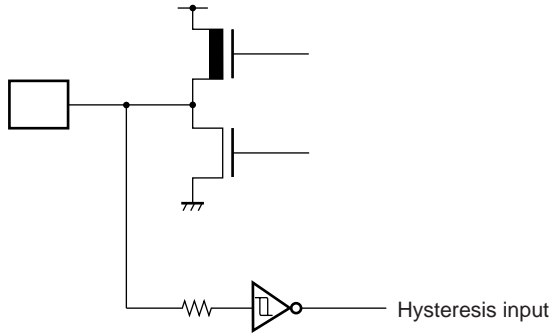
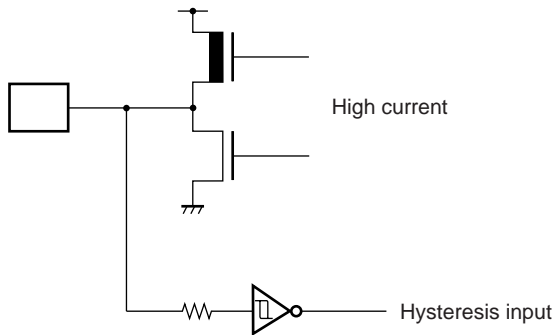
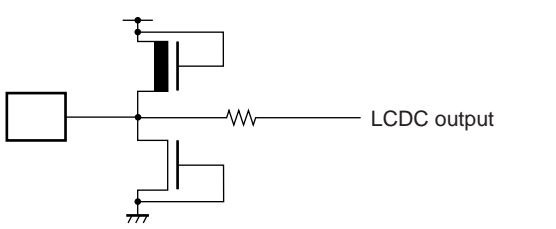
Type	Circuit	Remarks
F		<ul style="list-style-type: none"> • CMOS output • Hysteresis input • Analog input
G		<ul style="list-style-type: none"> • CMOS output • Hysteresis input
H		<ul style="list-style-type: none"> • CMOS high current output • Hysteresis input
I		<ul style="list-style-type: none"> • LCDC output

■ HANDLING DEVICES

Precautions for Handling Semiconductor Devices

- **Strictly observe maximum rated voltages (prevent latchup)**

When CMOS integrated circuit devices are subjected to applied voltages higher than V_{CC} at input and output pins other than medium- and high-withstand voltage pins, or to voltages lower than V_{SS} , or when voltages in excess of rated levels are applied between V_{CC} and V_{SS} , a phenomenon known as latchup can occur. In a latchup condition, supply current can increase dramatically and may destroy semiconductor elements. In using semiconductor devices, always take sufficient care to avoid exceeding maximum ratings.

Also care must be taken when power to analog systems is switched on or off, to ensure that the analog power supply (AV_{CC} , $AVRH$), analog input and dedicated power supply for the high current output buffer pins (DV_{CC}) do not exceed the digital power supply (V_{CC}).

Once the digital power supply (V_{CC}) is switched on, the analog power (AV_{CC} , $AVRH$) and dedicated power supply for the high current output buffer pins (DV_{CC}) may be turned on in any sequence.

- **Stable supply voltage**

Even within the warranted operating range of V_{CC} supply voltage, sudden fluctuations in supply voltage can cause abnormal operation. The recommended stability for ripple fluctuations (P-P values) at commercial frequencies (50 Hz to 60 Hz) should be within 10% of the standard V_{CC} value, and voltage fluctuations that occur during switching of power supplies etc. should be limited to transient fluctuation rates of 0.1 V/ms or less.

- **Power-on procedures**

In order to prevent abnormal operation of the internal built-in step-down circuits, voltage rise time during power-on should be attained within 50 μ s (0.2 V to 2.7 V).

- **Treatment of unused pins**

If unused input pins are left open, they may cause abnormal operation or latchup which may lead to permanent damage to the semiconductor. Any such pins should be pulled up or pulled down through resistance of at least 2 k Ω .

Any unused input/output pins should be left open in output status, or if found set to input status, they should be treated in the same way as input pins.

Any unused output pins should be left open.

- **Treatment of A/D converter power supply pins**

Even if the A/D converter is not used, pins should be connected so that $AV_{CC} = V_{CC}$, and $AV_{SS} = AVRH = V_{SS}$.

- **Use of external clock signals**

Even when an external clock is used, a stabilization period is required following a power-on reset or release from sub clock mode or stop mode. Also, when an external clock is used it should drive only the X0 pin and the X1 pin should be left open, as shown in the following figure.

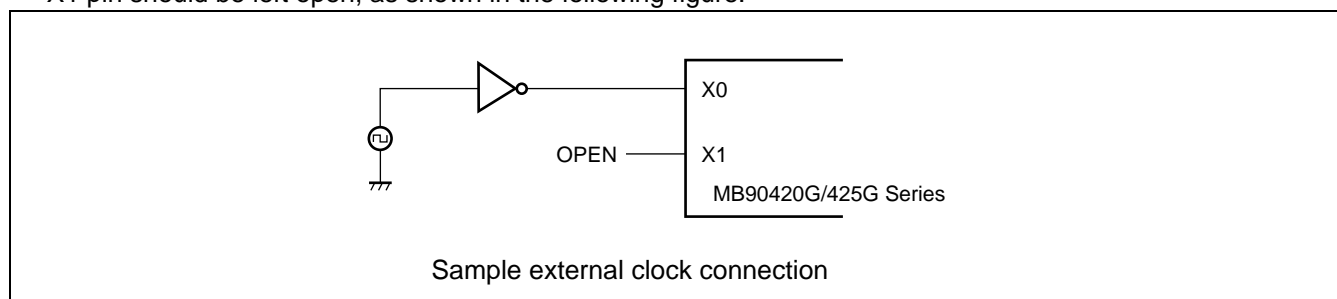

MB90420G/425G Series

• Power supply pins

Devices are designed to prevent problems such as latchup when multiple V_{CC} and V_{SS} supply pins are used, by providing internal connections between pins having the same potential. However, in order to reduce unwanted radiation, and to prevent abnormal operation of strobe signals due to rise in ground level, and to maintain total output current ratings, all such pins should always be connected externally to power supplies and ground.

As shown in figure below, all V_{CC} power supply pins must have the same potential. All V_{SS} power supply pins should be handled in the same way. If there are multiple V_{CC} or V_{SS} systems, the device will not operate properly even within the warranted operating range.

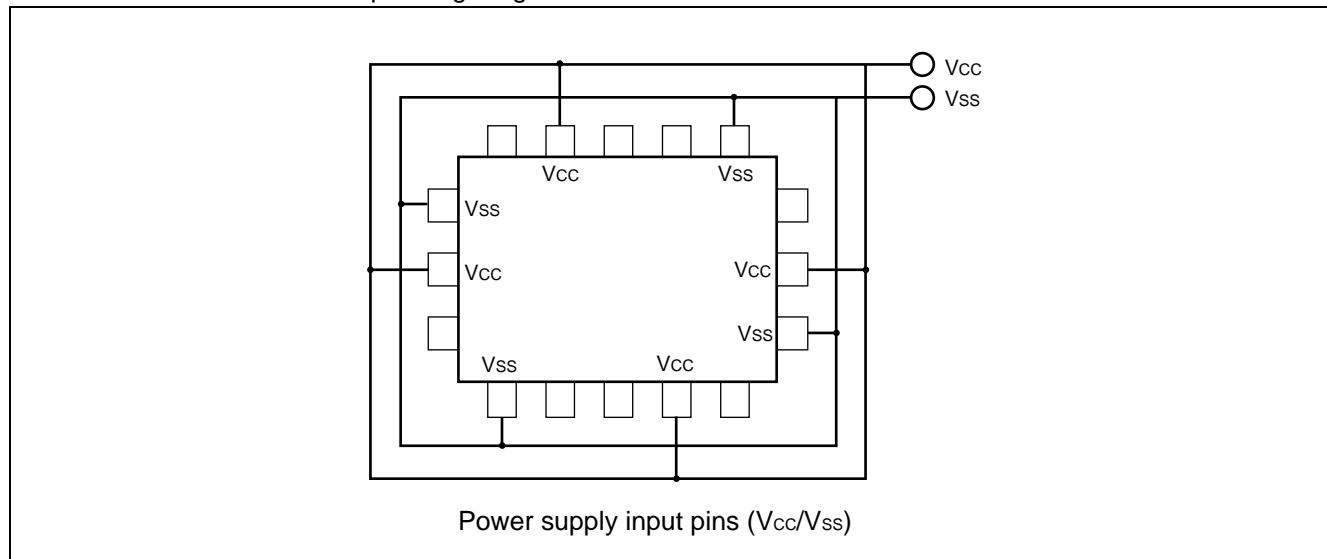

In addition, care must be given to connecting the V_{CC} and V_{SS} pins of this device to a current source with as little impedance as possible. It is recommended that a bypass capacitor of 1.0 μF be connected between V_{CC} and V_{SS} as close to the pins as possible.

• Proper sequence of A/D converter power supply analog input

A/D converter power (AV_{CC} , $AVRH$) and analog input ($AN0$ - $AN7$) must be applied after the digital power supply (V_{CC}) is switched on. When power is shut off, the A/D converter power supply and analog input must be cut off before the digital power supply is switched on (V_{CC}). In both power-on and shut-off, care should be taken that $AVRH$ does not exceed AV_{CC} . Even when pins which double as analog input pins are used as input ports, be sure that the input voltage does not exceed AV_{CC} . (There is no problem if analog power supplies and digital power supplies are turned off and on at the same time.)

• Handling the power supply for high-current output buffer pins (DV_{CC} , DV_{SS})

Always apply power to high-current output buffer pins (DV_{CC} , DV_{SS}) after the digital power supply (V_{CC}) is turned on. Also when switching power off, always shut off the power supply to the high-current output buffer pins (DV_{CC} , DV_{SS}) before switching off the digital power supply (V_{CC}). (There will be no problem if high-current output buffer pins and digital power supplies are turned off and on at the same time.)

Even when high-current output buffer pins are used as general purpose ports, the power for high current output buffer pins (DV_{CC} , DV_{SS}) should be applied to these pins.

• Pull-up/pull-down resistance

The MB90420G/425G series does not support internal pull-up/pull-down resistance. If necessary, use external components.

- **Precautions for when not using a sub clock signal.**

If the X0A and X1A pins are not connected to an oscillator, apply pull-down treatment to the X0A pin and leave the X1A pin open.

- **Notes on during operation of PLL clock mode**

If the PLL clock mode is selected, the microcontroller attempt to be working with the self-oscillating circuit even when there is no external oscillator or external clock input is stopped. Performance of this operation, however, cannot be guaranteed.

MB90420G/425G Series

■ BLOCK DIAGRAM

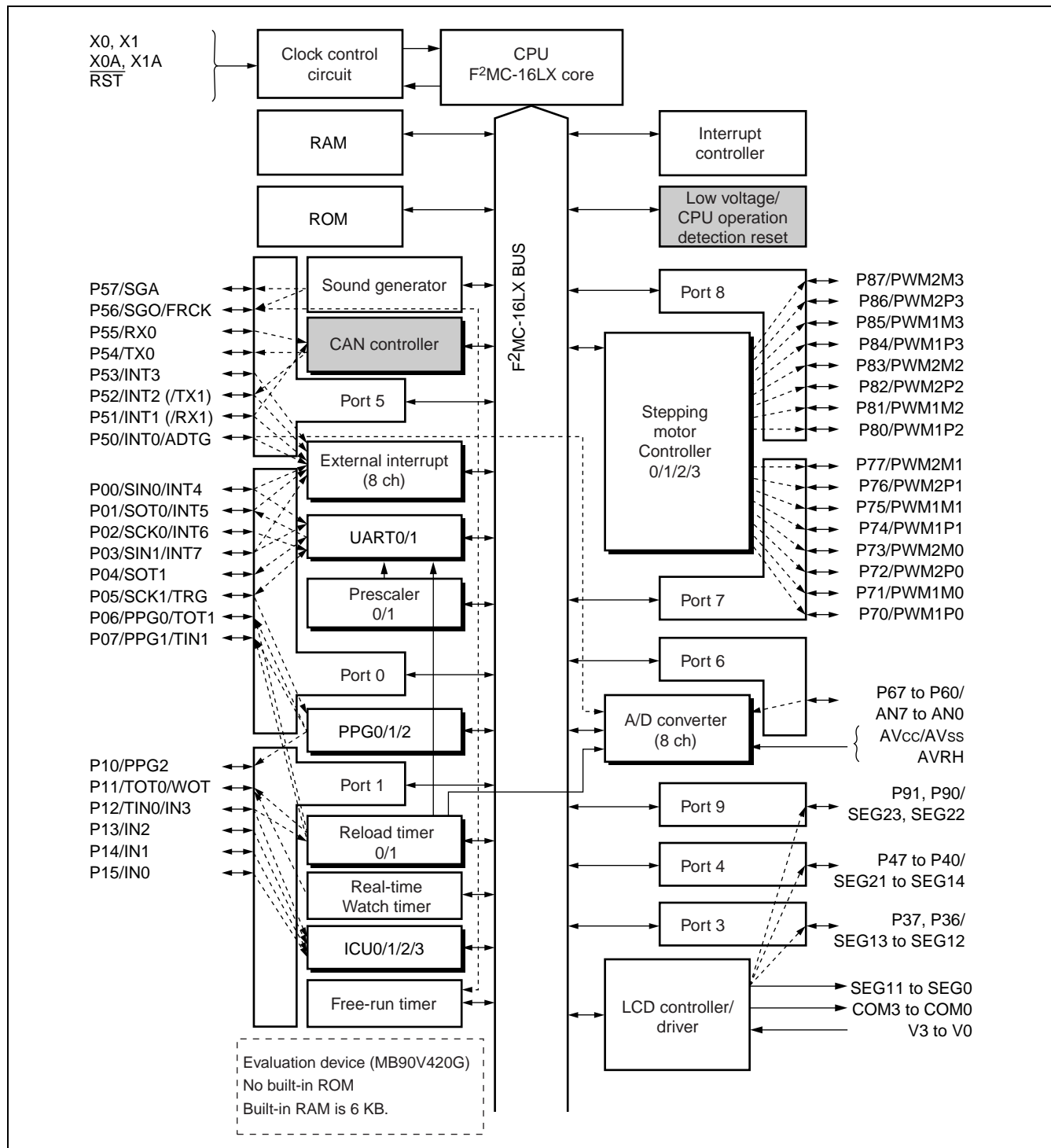

Note: MB90420G series is equipped with 2-channel CAN interface and MB90425G series is equipped with 1-channel CAN interface. MB90F423GA, MB90423GA, MB90F428GA, MB90427GA and MB90428GA have low voltage/CPU operation detection reset. MB90F423GC, MB90423GC, MB90F428GC, MB90427GC, MB90428GC and MB90V420G do not have low voltage/CPU operation detection reset. See "■ Product Lineup" for detail.

■ MEMORY MAP

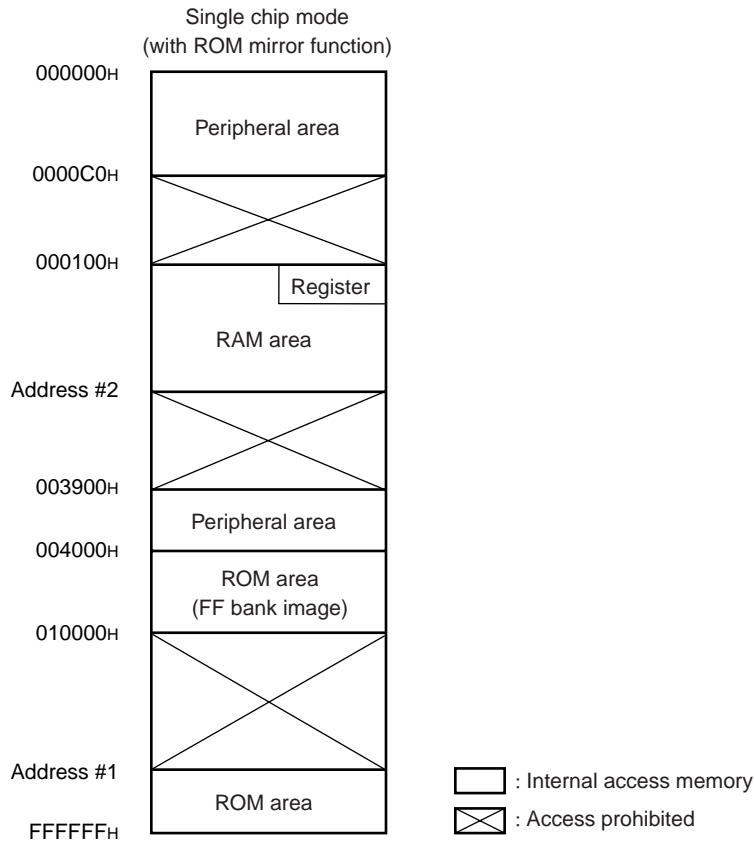

Parts No.	Address #1	Address #2
MB90423GA/GC	FE0000 _H	001900 _H
MB90427GA/GC	FF0000 _H	001100 _H
MB90428GA/GC	FE0000 _H	001900 _H
MB90F423GA/GC	FE0000 _H	001900 _H
MB90F428GA/GC	FE0000 _H	001900 _H
MB90V420G	FE0000 _H	001900 _H

Note : To select models without the ROM mirror function, see the “ROM Mirror Function Selection Module.” The image of the ROM data in the FF bank appears at the top of the 00 bank, in order to enable efficient use of small C compiler models. The lower 16-bit address for the FF bank will be assigned to the same address, so that tables in ROM can be referenced without declaring a “far” indication with the pointer. For example when accessing the address 00C000_H, the actual access is to address FFC000_H in ROM. Here the FF bank ROM area exceeds 48 KB, so that it is not possible to see the entire area in the 00 bank image. Therefore because the ROM data from FF4000_H to FFFFFFF_H will appear in the image from 004000_H to 00FFFF_H, it is recommended that the ROM data table be stored in the area from FF4000_H to FFFFFFF_H.

MB90420G/425G Series

■ I/O MAP

- Other than CAN Interface

Address	Register name	Symbol	Read/write	Peripheral function	Initial value
00H	Port 0 data register	PDR0	R/W	Port 0	XXXXXXXXXX
01H	Port 1 data register	PDR1	R/W	Port 1	- - XXXXXX
02H	(Disabled)				
03H	Port 3 data register	PDR3	R/W	Port 3	XX - - - - -
04H	Port 4 data register	PDR4	R/W	Port 4	XXXXXXXXXX
05H	Port 5 data register	PDR5	R/W	Port 5	XXXXXXXXXX
06H	Port 6 data register	PDR6	R/W	Port 6	XXXXXXXXXX
07H	Port 7 data register	PDR7	R/W	Port 7	XXXXXXXXXX
08H	Port 8 data register	PDR8	R/W	Port 8	XXXXXXXXXX
09H	Port 9 data register	PDR9	R/W	Port 9	- - - - - XX
0AH to 0FH	(Disabled)				
10H	Port 0 direction register	DDR0	R/W	Port 0	0 0 0 0 0 0 0
11H	Port 1 direction register	DDR1	R/W	Port 1	- - 0 0 0 0 0
12H	(Disabled)				
13H	Port 3 direction register	DDR3	R/W	Port 3	0 0 - - - - -
14H	Port 4 direction register	DDR4	R/W	Port 4	0 0 0 0 0 0 0
15H	Port 5 direction register	DDR5	R/W	Port 5	0 0 0 0 0 0 0
16H	Port 6 direction register	DDR6	R/W	Port 6	0 0 0 0 0 0 0
17H	Port 7 direction register	DDR7	R/W	Port 7	0 0 0 0 0 0 0
18H	Port 8 direction register	DDR8	R/W	Port 8	0 0 0 0 0 0 0
19H	Port 9 direction register	DDR9	R/W	Port 9	- - - - - 0 0
1AH	Analog input enable	ADER	R/W	Port 6, A/D	1 1 1 1 1 1 1
1BH to 1FH	(Disabled)				
20H	A/D control status register lower	ADCSL	R/W	A/D converter	0 0 0 0 0 0 0
21H	A/D control status register higher	ADCSH	R/W		0 0 0 0 0 0 0
22H	A/D data register lower	ADCRL	R		XXXXXXXXXX
23H	A/D data register higher	ADCRH	R/W		0 0 1 0 1 XXX
24H	Compare clear register	CPCLR	R/W	16-bit free-run timer	XXXXXXXXXX
25H			R/W		XXXXXXXXXX
26H	Timer data register	TCDT	R/W		0 0 0 0 0 0 0
27H			R/W		0 0 0 0 0 0 0
28H	Timer control status register lower	TCCSL	R/W		0 0 0 0 0 0 0
29H	Timer control status register higher	TCCSH	R/W		0 - - 0 0 0 0

(Continued)

MB90420G/425G Series

Address	Register name	Symbol	Read/write	Peripheral function	Initial value
2A _H	PPG0 control status register lower	PCNTL0	R/W	16-bit PPG0	0 0 0 0 0 0 0 0
2B _H	PPG0 control status register higher	PCNTH0	R/W		0 0 0 0 0 0 0 -
2C _H	PPG1 control status register lower	PCNTL1	R/W	16-bit PPG1	0 0 0 0 0 0 0 0
2D _H	PPG1 control status register higher	PCNTH1	R/W		0 0 0 0 0 0 0 -
2E _H	PPG2 control status register lower	PCNTL2	R/W	16-bit PPG2	0 0 0 0 0 0 0 0
2F _H	PPG2 control status register higher	PCNTH2	R/W		0 0 0 0 0 0 0 -
30 _H	External interrupt enable	ENIR	R/W	External interrupt	0 0 0 0 0 0 0 0
31 _H	External interrupt request	EIRR	R/W		0 0 0 0 0 0 0 0
32 _H	External interrupt level lower	ELVRL	R/W		0 0 0 0 0 0 0 0
33 _H	External interrupt level higher	ELVRH	R/W		0 0 0 0 0 0 0 0
34 _H	Serial mode register 0	SMR0	R/W	UART 0	0 0 0 0 0 - 0 0
35 _H	Serial control register 0	SCR0	R/W		0 0 0 0 0 1 0 0
36 _H	Input data register 0/ Output data register 0	SIDR0/ SODR0	R/W		XXXXXXXXXX
37 _H	Serial status register 0	SSR0	R/W		0 0 0 0 1 0 0 0
38 _H	Serial mode register 1	SMR1	R/W	UART 1	0 0 0 0 0 - 0 0
39 _H	Serial control register 1	SCR1	R/W		0 0 0 0 0 1 0 0
3A _H	Input data register 1/ Output data register 1	SIDR1/ SODR1	R/W		XXXXXXXXXX
3B _H	Serial status register 1	SSR1	R/W		0 0 0 0 1 0 0 0
3C _H	(Disabled)				
3D _H	Clock division control register 0	CDCR0	R/W	Prescaler	0 - - - 0 0 0 0
3E _H	CAN wake-up control register	CWUCR	R/W	CAN	- - - - - - 0
3F _H	Clock division control register 1	CDCR1	R/W	Prescaler	0 - - - 0 0 0 0
40 _H to 4F _H	Area reserved for CAN interface 0				
50 _H	Timer control status register 0 lower	TMCSR0L	R/W	16-bit reload timer 0	0 0 0 0 0 0 0 0
51 _H	Timer control status register 0 higher	TMCSR0H	R/W		- - - 0 0 0 0 0
52 _H	Timer register 0/ Reload register 0	TMR0/ TMRLR0	R/W		XXXXXXXXXX
53 _H		XXXXXXXXXX			
54 _H	Timer control status register 1 lower	TMCSR1L	R/W	16-bit reload timer 1	0 0 0 0 0 0 0 0
55 _H	Timer control status register 1 higher	TMCSR1H	R/W		- - - 0 0 0 0 0
56 _H	Timer register 1/ Reload register 1	TMR1/ TMRLR1	R/W		XXXXXXXXXX
57 _H		XXXXXXXXXX			
58 _H	Watch timer control register lower	WTCRL	R/W	Real-time watch timer	0 0 0 - - 0 0 0
59 _H	Watch timer control register higher	WTCRH	R/W		0 0 0 0 0 0 0 0

(Continued)

MB90420G/425G Series

Address	Register name	Symbol	Read/write	Peripheral function	Initial value
5A _H	Sound control register lower	SGCRL	R/W	Sound generator	0 0 0 0 0 0 0 0
5B _H	Sound control register higher	SGCRH	R/W		0 - - - - 0 0
5C _H	Frequency data register	SGFR	R/W		XXXXXXXXXX
5D _H	Amplitude data register	SGAR	R/W		0 0 0 0 0 0 0 0
5E _H	Decrement grade register	SGDR	R/W		XXXXXXXXXX
5F _H	Tone count register	SGTR	R/W		XXXXXXXXXX
60 _H	Input capture register 0	IPCP0	R	Input capture 0/1	XXXXXXXXXX
61 _H					XXXXXXXXXX
62 _H	Input capture register 1	IPCP1	R		XXXXXXXXXX
63 _H					XXXXXXXXXX
64 _H	Input capture register 2	IPCP2	R	Input capture 2/3	XXXXXXXXXX
65 _H					XXXXXXXXXX
66 _H	Input capture register 3	IPCP3	R		XXXXXXXXXX
67 _H					XXXXXXXXXX
68 _H	Input capture control status 0/1	ICS01	R/W	Input capture 0/1	0 0 0 0 0 0 0 0
69 _H	(Disabled)				
6A _H	Input capture control status 2/3	ICS23	R/W	Input capture 2/3	0 0 0 0 0 0 0 0
6B _H	(Disabled)				
6C _H	LCD control register lower	LCRL	R/W	LCD controller/ driver	0 0 0 1 0 0 0 0
6D _H	LCD control register higher	LCRH	R/W		0 0 0 0 0 0 0 0
6E _H	Low voltage/CPU operation detection reset control register	LVRC	R/W	Low voltage/CPU operation detection reset	1 0 1 1 1 0 0 0
6F _H	ROM mirror	ROMM	W	ROM mirror	XXXXXXXXX1
70 _H to 7F _H	Area reserved for CAN interface 1				
80 _H	PWM control register 0	PWC0	R/W	Stepping motor controller0	0 0 0 0 0 - - 0
81 _H	(Disabled)				
82 _H	PWM control register 1	PWC1	R/W	Stepping motor controller1	0 0 0 0 0 - - 0
83 _H	(Disabled)				
84 _H	PWM control register 2	PWC2	R/W	Stepping motor controller2	0 0 0 0 0 - - 0
85 _H	(Disabled)				
86 _H	PWM control register 3	PWC3	R/W	Stepping motor controller3	0 0 0 0 0 - - 0
87 _H to 9D _H	(Disabled)				

(Continued)

MB90420G/425G Series

Address	Register name	Symbol	Read/write	Peripheral function	Initial value
9E _H	ROM correction control register	PACSR	R/W	Address match detection function	-----0-0
9F _H	Delay interrupt/release	DIRR	R/W	Delayed interrupt	-----0
A0 _H	Power saving mode	LPMCR	R/W	Power saving control circuit	00011000
A1 _H	Clock select	CKSCR	R/W		11111100
A2 _H to A7 _H	(Disabled)				
A8 _H	Watchdog control	WDTC	R/W	Watchdog timer	XXXXX111
A9 _H	Time base timer control register	TBTC	R/W	Time base timer	1--00100
AA _H	Watch timer control register	WTC	R/W	Watch timer (sub-clock)	1X000000
AB _H to AD _H	(Disabled)				
AE _H	Flash control register	FMCS	R/W	Flash interface	000X0XX0
AF _H	(Disabled)				
B0 _H	Interrupt control register 00	ICR00	R/W	Interrupt controller	00000111
B1 _H	Interrupt control register 01	ICR01	R/W		00000111
B2 _H	Interrupt control register 02	ICR02	R/W		00000111
B3 _H	Interrupt control register 03	ICR03	R/W		00000111
B4 _H	Interrupt control register 04	ICR04	R/W		00000111
B5 _H	Interrupt control register 05	ICR05	R/W		00000111
B6 _H	Interrupt control register 06	ICR06	R/W		00000111
B7 _H	Interrupt control register 07	ICR07	R/W		00000111
B8 _H	Interrupt control register 08	ICR08	R/W		00000111
B9 _H	Interrupt control register 09	ICR09	R/W		00000111
BA _H	Interrupt control register 10	ICR10	R/W		00000111
BB _H	Interrupt control register 11	ICR11	R/W		00000111
BC _H	Interrupt control register 12	ICR12	R/W		00000111
BD _H	Interrupt control register 13	ICR13	R/W		00000111
BE _H	Interrupt control register 14	ICR14	R/W		00000111
BF _H	Interrupt control register 15	ICR15	R/W		00000111
C0 _H to FF _H	(Disabled)				

(Continued)

MB90420G/425G Series

Address	Register name	Symbol	Read/write	Peripheral function	Initial value
1FF0 _H	ROM correction address 0	PADR0	R/W	Address match detection function	XXXXXXXXXX
1FF1 _H	ROM correction address 1	PADR0	R/W		XXXXXXXXXX
1FF2 _H	ROM correction address 2	PADR0	R/W		XXXXXXXXXX
1FF3 _H	ROM correction address 3	PADR1	R/W		XXXXXXXXXX
1FF4 _H	ROM correction address 4	PADR1	R/W		XXXXXXXXXX
1FF5 _H	ROM correction address 5	PADR1	R/W		XXXXXXXXXX
3900 _H to 391F _H	(Disabled)				
3920 _H	PPG0 down counter register	PDCR0	R	16-bit PPG 0	1 1 1 1 1 1 1 1
3921 _H					1 1 1 1 1 1 1 1
3922 _H	PPG0 cycle setting register	PCSR0	W		XXXXXXXXXX
3923 _H					XXXXXXXXXX
3924 _H	PPG0 duty setting register	PDUT0	W		XXXXXXXXXX
3925 _H					XXXXXXXXXX
3926 _H to 3927 _H	(Disabled)				
3928 _H	PPG1 down counter register	PDCR1	R	16-bit PPG 1	1 1 1 1 1 1 1 1
3929 _H					1 1 1 1 1 1 1 1
392A _H	PPG1 cycle setting register	PCSR1	W		XXXXXXXXXX
392B _H					XXXXXXXXXX
392C _H	PPG1 duty setting register	PDUT1	W		XXXXXXXXXX
392D _H					XXXXXXXXXX
392E _H to 392F _H	(Disabled)				
3930 _H	PPG2 down counter register	PDCR2	R	16 bit PPG 2	1 1 1 1 1 1 1 1
3931 _H					1 1 1 1 1 1 1 1
3932 _H	PPG2 cycle setting register	PCSR2	W		XXXXXXXXXX
3933 _H					XXXXXXXXXX
3934 _H	PPG2 duty setting register	PDUT2	W		XXXXXXXXXX
3935 _H					XXXXXXXXXX
3936 _H to 3959 _H	(Disabled)				

(Continued)

MB90420G/425G Series

Address	Register name	Symbol	Read/write	Peripheral function	Initial value
395A _H	Sub second data register	WTBR	R/W	Real time watch timer	XXXXXXXX
395B _H					XXXXXXXX
395C _H					- - - XXXXX
395D _H	Second data register	WTSR	R/W		-- XXXXXX
395E _H	Minute data register	WTMR	R/W		-- XXXXXX
395F _H	Hour data register	WTHR	R/W		- - - XXXXX
3960 _H to 396B _H	LCD display RAM	VRAM	R/W	LCD controller/driver	XXXXXXXX
396C _H to 397F _H	(Disabled)				
3980 _H	PWM1 compare register 0	PWC10	R/W	Stepping motor controller 0	XXXXXXXX
3981 _H					- - - - - XX
3982 _H	PWM2 compare register 0	PWC20	R/W		XXXXXXXX
3983 _H					- - - - - XX
3984 _H	PWM1 select register 0	PWS10	R/W		- - 000000
3985 _H	PWM2 select register 0	PWS20	R/W		- 0000000
3986 _H to 3987 _H	(Disabled)				
3988 _H	PWM1 compare register 1	PWC11	R/W	Stepping motor controller 1	XXXXXXXX
3989 _H					- - - - - XX
398A _H	PWM2 compare register 1	PWC21	R/W		XXXXXXXX
398B _H					- - - - - XX
398C _H	PWM1 select register 1	PWS11	R/W		- - 000000
398D _H	PWM2 select register 1	PWS21	R/W		- 0000000
398E _H to 398F _H	(Disabled)				
3990 _H	PWM1 compare register 2	PWC12	R/W	Stepping motor controller 2	XXXXXXXX
3991 _H					- - - - - XX
3992 _H	PWM2 compare register 2	PWC22	R/W		XXXXXXXX
3993 _H					- - - - - XX
3994 _H	PWM1 select register 2	PWS12	R/W		- - 000000
3995 _H	PWM2 select register 2	PWS22	R/W		- 0000000
3996 _H to 3997 _H	(Disabled)				

(Continued)

MB90420G/425G Series

(Continued)

Address	Register name	Symbol	Read/write	Peripheral function	Initial value
3998 _H	PWM1 compare register 3	PWC13	R/W	Stepping motor controller 3	XXXXXXXXXX
3999 _H					-----XX
399A _H	PWM2 compare register 3	PWC23	R/W		XXXXXXXXXX
399B _H					-----XX
399C _H	PWM1 select register 3	PWS13	R/W		--000000
399D _H	PWM2 select register 3	PWS23	R/W		-0000000
399E _H to 39FF _H	(Disabled)				
3A00 _H to 3AFF _H	Area reserved for CAN interface 0				
3B00 _H to 3BFF _H	Area reserved for CAN interface 1				
3C00 _H to 3CFF _H	Area reserved for CAN interface 0				
3D00 _H to 3DFF _H	Area reserved for CAN interface 1				
3E00 _H to 3EFF _H	(Disabled)				

- Initial value symbols :
 - “0” initial value 0.
 - “1” initial value 1.
 - “X” initial value undetermined
 - “-” initial value undetermined (none)
- Write/read symbols :
 - “R/W” read/write enabled
 - “R” read only
 - “W” write only
- Addresses in the area 0000_H to 00FF_H are reserved for the principal functions of the MCU. Read access attempts to reserved areas will result in an “X” value. Also, write access to reserved areas is prohibited.

MB90420G/425G Series

• I/O Map for CAN Interface

Address		Register name	Symbol	Read/write	Initial value
CAN0	CAN1				
000040 _H	000070 _H	Message buffer valid area	BVALR	(R/W)	00000000 00000000
000041 _H	000071 _H				
000042 _H	000072 _H	Transmission request register	TREQR	(R/W)	00000000 00000000
000043 _H	000073 _H				
000044 _H	000074 _H	Transmission cancel register	TCANR	(W)	00000000 00000000
000045 _H	000075 _H				
000046 _H	000076 _H	Transmission completed register	TCR	(R/W)	00000000 00000000
000047 _H	000077 _H				
000048 _H	000078 _H	Receiving completed register	RCR	(R/W)	00000000 00000000
000049 _H	000079 _H				
00004A _H	00007A _H	Remote request receiving register	RRTRR	(R/W)	00000000 00000000
00004B _H	00007B _H				
00004C _H	00007C _H	Receiving overrun register	ROVRR	(R/W)	00000000 00000000
00004D _H	00007D _H				
00004E _H	00007E _H	Receiving interrupt enable register	RIER	(R/W)	00000000 00000000
00004F _H	00007F _H				
003C00 _H	003D00 _H	Control status register	CSR	(R/W, R)	00---000 0----0-1
003C01 _H	003D01 _H				
003C02 _H	003D02 _H	Last event indicator register	LEIR	(R/W)	----- 000-0000
003C03 _H	003D03 _H				
003C04 _H	003D04 _H	RX/TX error counter	RTEC	(R)	00000000 00000000
003C05 _H	003D05 _H				
003C06 _H	003D06 _H	Bit timing register	BTR	(R/W)	-1111111 11111111
003C07 _H	003D07 _H				
003C08 _H	003D08 _H	IDE register	IDER	(R/W)	XXXXXXXX XXXXXXXX
003C09 _H	003D09 _H				
003C0A _H	003D0A _H	Transmission RTR register	TRTRR	(R/W)	00000000 00000000
003C0B _H	003D0B _H				
003C0C _H	003D0C _H	Remote frame receiving wait register	RFWTR	(R/W)	XXXXXXXX XXXXXXXX
003C0D _H	003D0D _H				
003C0E _H	003D0E _H	Transmission interrupt enable register	TIER	(R/W)	00000000 00000000
003C0F _H	003D0F _H				

(Continued)

MB90420G/425G Series

Address		Register name	Symbol	Read/ write	Initial value
CAN0	CAN1				
003C10 _H	003D10 _H	Acceptance mask select register	AMSR	(R/W)	XXXXXXXX XXXXXXXX
003C11 _H	003D11 _H				
003C12 _H	003D12 _H				
003C13 _H	003D13 _H				
003C14 _H	003D14 _H	Acceptance mask register 0	AMR0	(R/W)	XXXXXXXX XXXXXXXX
003C15 _H	003D15 _H				
003C16 _H	003D16 _H				
003C17 _H	003D17 _H				
003C18 _H	003D18 _H	Acceptance mask register 1	AMR1	(R/W)	XXXXXXXX XXXXXXXX
003C19 _H	003D19 _H				
003C1A _H	003D1A _H				
003C1B _H	003D1B _H				
003A00 _H to 003A1F _H	003B00 _H to 003B1F _H	General purpose RAM	—	(R/W)	XXXXXXXX to XXXXXXXX
003A20 _H	003B20 _H	ID register 0	IDR0	(R/W)	XXXXXXXX XXXXXXXX
003A21 _H	003B21 _H				
003A22 _H	003B22 _H				
003A23 _H	003B23 _H				
003A24 _H	003B24 _H	ID register 1	IDR1	(R/W)	XXXXXXXX XXXXXXXX
003A25 _H	003B25 _H				
003A26 _H	003B26 _H				
003A27 _H	003B27 _H				
003A28 _H	003B28 _H	ID register 2	IDR2	(R/W)	XXXXXXXX XXXXXXXX
003A29 _H	003B29 _H				
003A2A _H	003B2A _H				
003A2B _H	003B2B _H				
003A2C _H	003B2C _H	ID register 3	IDR3	(R/W)	XXXXXXXX XXXXXXXX
003A2D _H	003B2D _H				
003A2E _H	003B2E _H				
003A2F _H	003B2F _H				
003A30 _H	003B30 _H	ID register 4	IDR4	(R/W)	XXXXXXXX XXXXXXXX
003A31 _H	003B31 _H				
003A32 _H	003B32 _H				
003A33 _H	003B33 _H				

(Continued)

MB90420G/425G Series

Address		Register name	Symbol	Read/ write	Initial value	
CAN0	CAN1					
003A34 _H	003B34 _H	ID register 5	IDR5	(R/W)	XXXXXXXX	XXXXXXXX
003A35 _H	003B35 _H				XXXXX- - -	XXXXXXXX
003A36 _H	003B36 _H					
003A37 _H	003B37 _H					
003A38 _H	003B38 _H	ID register 6	IDR6	(R/W)	XXXXXXXX	XXXXXXXX
003A39 _H	003B39 _H				XXXXX- - -	XXXXXXXX
003A3A _H	003B3A _H					
003A3B _H	003B3B _H					
003A3C _H	003B3C _H	ID register 7	IDR7	(R/W)	XXXXXXXX	XXXXXXXX
003A3D _H	003B3D _H				XXXXX- - -	XXXXXXXX
003A3E _H	003B3E _H					
003A3F _H	003B3F _H					
003A40 _H	003B40 _H	ID register 8	IDR8	(R/W)	XXXXXXXX	XXXXXXXX
003A41 _H	003B41 _H				XXXXX- - -	XXXXXXXX
003A42 _H	003B42 _H					
003A43 _H	003B43 _H					
003A44 _H	003B44 _H	ID register 9	IDR9	(R/W)	XXXXXXXX	XXXXXXXX
003A45 _H	003B45 _H				XXXXX- - -	XXXXXXXX
003A46 _H	003B46 _H					
003A47 _H	003B47 _H					
003A48 _H	003B48 _H	ID register 10	IDR10	(R/W)	XXXXXXXX	XXXXXXXX
003A49 _H	003B49 _H				XXXXX- - -	XXXXXXXX
003A4A _H	003B4A _H					
003A4B _H	003B4B _H					
003A4C _H	003B4C _H	ID register 11	IDR11	(R/W)	XXXXXXXX	XXXXXXXX
003A4D _H	003B4D _H				XXXXX- - -	XXXXXXXX
003A4E _H	003B4E _H					
003A4F _H	003B4F _H					
003A50 _H	003B50 _H	ID register 12	IDR12	(R/W)	XXXXXXXX	XXXXXXXX
003A51 _H	003B51 _H				XXXXX- - -	XXXXXXXX
003A52 _H	003B52 _H					
003A53 _H	003B53 _H					

(Continued)

MB90420G/425G Series

Address		Register name	Symbol	Read/write	Initial value	
CAN0	CAN1					
003A54 _H	003B54 _H	ID register 13	IDR13	(R/W)	XXXXXXXX	XXXXXXXX
003A55 _H	003B55 _H					
003A56 _H	003B56 _H				XXXXX- - -	XXXXXXXX
003A57 _H	003B57 _H					
003A58 _H	003B58 _H	ID register 14	IDR14	(R/W)	XXXXXXXX	XXXXXXXX
003A59 _H	003B59 _H					
003A5A _H	003B5A _H				XXXXX- - -	XXXXXXXX
003A5B _H	003B5B _H					
003A5C _H	003B5C _H	ID register 15	IDR15	(R/W)	XXXXXXXX	XXXXXXXX
003A5D _H	003B5D _H					
003A5E _H	003B5E _H				XXXXX- - -	XXXXXXXX
003A5F _H	003B5F _H					
003A60 _H	003B60 _H	DLC register 0	DLCR0	(R/W)	- - - -XXXX	- - - -XXXX
003A61 _H	003B61 _H					
003A62 _H	003B62 _H	DLC register 1	DLCR1	(R/W)	- - - -XXXX	- - - -XXXX
003A63 _H	003B63 _H					
003A64 _H	003B64 _H	DLC register 2	DLCR2	(R/W)	- - - -XXXX	- - - -XXXX
003A65 _H	003B65 _H					
003A66 _H	003B66 _H	DLC register 3	DLCR3	(R/W)	- - - -XXXX	- - - -XXXX
003A67 _H	003B67 _H					
003A68 _H	003B68 _H	DLC register 4	DLCR4	(R/W)	- - - -XXXX	- - - -XXXX
003A69 _H	003B69 _H					
003A6A _H	003B6A _H	DLC register 5	DLCR5	(R/W)	- - - -XXXX	- - - -XXXX
003A6B _H	003B6B _H					
003A6C _H	003B6C _H	DLC register 6	DLCR6	(R/W)	- - - -XXXX	- - - -XXXX
003A6D _H	003B6D _H					
003A6E _H	003B6E _H	DLC register 7	DLCR7	(R/W)	- - - -XXXX	- - - -XXXX
003A6F _H	003B6F _H					
003A70 _H	003B70 _H	DLC register 8	DLCR8	(R/W)	- - - -XXXX	- - - -XXXX
003A71 _H	003B71 _H					
003A72 _H	003B72 _H	DLC register 9	DLCR9	(R/W)	- - - -XXXX	- - - -XXXX
003A73 _H	003B73 _H					
003A74 _H	003B74 _H	DLC register 10	DLCR10	(R/W)	- - - -XXXX	- - - -XXXX
003A75 _H	003B75 _H					

(Continued)

MB90420G/425G Series

Address		Register name	Symbol	Read/ write	Initial value
CAN0	CAN1				
003A76H	003B76H	DLC register 11	DLCR11	(R/W)	----XXXX ----XXXX
003A77H	003B77H				
003A78H	003B78H	DLC register 12	DLCR12	(R/W)	----XXXX ----XXXX
003A79H	003B79H				
003A7AH	003B7AH	DLC register 13	DLCR13	(R/W)	----XXXX ----XXXX
003A7BH	003B7BH				
003A7CH	003B7CH	DLC register 14	DLCR14	(R/W)	----XXXX ----XXXX
003A7DH	003B7DH				
003A7EH	003B7EH	DLC register 15	DLCR15	(R/W)	----XXXX ----XXXX
003A7FH	003B7FH				
003A80H to 003A87H	003B80H to 003B87H	Data register 0 (8 bytes)	DTR0	(R/W)	XXXXXXXX to XXXXXXXX
003A88H to 003A8FH	003B88H to 003B8FH	Data register 1 (8 bytes)	DTR1	(R/W)	XXXXXXXX to XXXXXXXX
003A90H to 003A87H	003B90H to 003B97H	Data register 2 (8 bytes)	DTR2	(R/W)	XXXXXXXX to XXXXXXXX
003A98H to 003A9FH	003B98H to 003B9FH	Data register 3 (8 bytes)	DTR3	(R/W)	XXXXXXXX to XXXXXXXX
003AA0H to 003AA7H	003BA0H to 003BA7H	Data register 4 (8 bytes)	DTR4	(R/W)	XXXXXXXX to XXXXXXXX
003AA8H to 003AAFH	003BA8H to 003BAFH	Data register 5 (8 bytes)	DTR5	(R/W)	XXXXXXXX to XXXXXXXX
003AB0H to 003AB7H	003BB0H to 003BB7H	Data register 6 (8 bytes)	DTR6	(R/W)	XXXXXXXX to XXXXXXXX
003AB8H to 003ABFH	003BB8H to 003BBFH	Data register 7 (8 bytes)	DTR7	(R/W)	XXXXXXXX to XXXXXXXX
003AC0H to 003AC7H	003BC0H to 003BC7H	Data register 8 (8 bytes)	DTR8	(R/W)	XXXXXXXX to XXXXXXXX
003AC8H to 003ACFH	003BC8H to 003BCFH	Data register 9 (8 bytes)	DTR9	(R/W)	XXXXXXXX to XXXXXXXX

(Continued)

MB90420G/425G Series

(Continued)

Address		Register name	Symbol	Read/ write	Initial value
CAN0	CAN1				
003AD0 _H to 003AD7 _H	003BD0 _H to 003BD7 _H	Data register 10 (8 bytes)	DTR10	(R/W)	XXXXXXXX to XXXXXXXX
003AD8 _H to 003ADF _H	003BD8 _H to 003BDF _H	Data register 11 (8 bytes)	DTR11	(R/W)	XXXXXXXX to XXXXXXXX
003AE0 _H to 003AE7 _H	003BE0 _H to 003BE7 _H	Data register 12 (8 bytes)	DTR12	(R/W)	XXXXXXXX to XXXXXXXX
003AE8 _H to 003AEF _H	003BE8 _H to 003BEF _H	Data register 13 (8 bytes)	DTR13	(R/W)	XXXXXXXX to XXXXXXXX
003AF0 _H to 003AF7 _H	003BF0 _H to 003BF7 _H	Data register 14 (8 bytes)	DTR14	(R/W)	XXXXXXXX to XXXXXXXX
003AF8 _H to 003AFF _H	003BF8 _H to 003BFF _H	Data register 15 (8 bytes)	DTR15	(R/W)	XXXXXXXX to XXXXXXXX

MB90420G/425G Series

■ INTERRUPT SOURCES, INTERRUPT VECTORS, AND INTERRUPT CONTROL REGISTERS

Interrupt source	EPOS compatible	Interrupt vector		Interrupt control register		Priority *2	
		Number	Address	ICR	Address		
Reset	×	#08	08H	FFFFDC _H	—	—	↑ High ↓ Low
INT9 instruction	×	#09	09H	FFFFD8 _H	—	—	
Exception processing	×	#10	0AH	FFFFD4 _H	—	—	
CAN0 RX	×	#11	0BH	FFFFD0 _H	ICR00	0000B0 _H *1	
CAN0 TX/NS	×	#12	0CH	FFFFCC _H			
CAN1 RX	×	#13	0DH	FFFFC8 _H	ICR01	0000B1 _H *1	
CAN1 TX/NS	×	#14	0EH	FFFFC4 _H			
Input capture 0	△	#15	0FH	FFFFC0 _H	ICR02	0000B2 _H *1	
DTP/external interrupt - ch 0 detected	△	#16	10H	FFFFBC _H			
Reload timer 0	△	#17	11H	FFFFB8 _H	ICR03	0000B3 _H *1	
DTP/external interrupt - ch 1 detected	△	#18	12H	FFFFB4 _H			
Input capture 1	△	#19	13H	FFFFB0 _H	ICR04	0000B4 _H *1	
DTP/external interrupt - ch 2 detected	△	#20	14H	FFFFAC _H			
Input capture 2	△	#21	15H	FFFFA8 _H	ICR05	0000B5 _H *1	
DTP/external interrupt - ch 3 detected	△	#22	16H	FFFFA4 _H			
Input capture 3	△	#23	17H	FFFFA0 _H	ICR06	0000B6 _H *1	
DTP/external interrupt - ch 4/5 detected	△	#24	18H	FFFF9C _H			
PPG timer 0	△	#25	19H	FFFF98 _H	ICR07	0000B7 _H *1	
DTP/external interrupt - ch 6/7 detected	△	#26	1AH	FFFF94 _H			
PPG timer 1	△	#27	1BH	FFFF90 _H	ICR08	0000B8 _H *1	
Reload timer 1	△	#28	1CH	FFFF8C _H			
PPG timer 2	○	#29	1DH	FFFF88 _H	ICR09	0000B9 _H *1	
Real time watch timer	×	#30	1EH	FFFF84 _H			
Free-run timer over flow	×	#31	1FH	FFFF80 _H	ICR10	0000BA _H *1	
A/D converter conversion end	○	#32	20H	FFFF7C _H			
Free-run timer clear	×	#33	21H	FFFF78 _H	ICR11	0000BB _H *1	
Sound generator	×	#34	22H	FFFF74 _H			
Time base timer	×	#35	23H	FFFF70 _H	ICR12	0000BC _H *1	
Watch timer (sub-clock)	×	#36	24H	FFFF6C _H			
UART 1 RX	◎	#37	25H	FFFF68 _H	ICR13	0000BD _H *1	
UART 1 TX	△	#38	26H	FFFF64 _H			
UART 0 RX	◎	#39	27H	FFFF60 _H	ICR14	0000BE _H *1	
UART 0 TX	△	#40	28H	FFFF5C _H			
Flash memory status	×	#41	29H	FFFF58 _H	ICR15	0000BF _H *1	
Delayed interrupt generator module	×	#42	2AH	FFFF54 _H			

MB90420G/425G Series

◎ : Compatible, with EI²OS stop function

○ : Compatible

△ : Compatible when interrupt sources sharing ICR are not in use

× : Not compatible

*1 : • Peripheral functions sharing the ICR register have the same interrupt level.

• If peripheral functions sharing the ICR register are using expanded intelligent I/O services, one or the other cannot be used.

• When peripheral functions are sharing the ICR register and one specifies expanded intelligent I/O services, the interrupt from the other function cannot be used.

*2 : Priority applies when interrupts of the same level are generated.

■ PERIPHERAL FUNCTIONS

1. I/O Ports

The I/O ports function is to send data from the CPU to be output from I/O pins and load input signals at the I/O pins into the CPU, according to the port data register (PDR) . Port input/output at I/O pins can be controlled in bit units by the port direction register (DDR) as required. The following list shows each of the functions as well as the shared peripheral function for each port.

- Port 0 : General purpose I/O port, shared with peripheral functions (external interrupt/UART/PPG)
- Port 1 : General purpose I/O port, shared with peripheral functions (PPG/reload timer/watch timer/ICU)
- Port 3 : General purpose I/O port, shared with peripheral functions (LCD)
- Port 4 : General purpose I/O port, shared with peripheral functions (LCD)
- Port 5 : General purpose I/O port, shared with peripheral functions (External interrupt/CAN/SG)
- Port 6 : General purpose I/O port, shared with peripheral functions (A/D converter)
- Port 7 : General purpose I/O port, shared with peripheral functions (Stepping motor controller)
- Port 8 : General purpose I/O port, shared with peripheral functions (Stepping motor controller)
- Port 9 : General purpose I/O port, shared with peripheral functions (LCD)

(1) List of Functions

Port	Pin name	Input format	Output format	Function
Port 0	P00/SIN0/INT4 to P07/PPG1	CMOS (hysteresis) (Automotive level*)	CMOS	General purpose I/O port
				Peripheral function
Port 1	P10/PPG2 to P15/IN0			General purpose I/O port
				Peripheral function
Port 3	P36/SEG12, P37/SEG13			General purpose I/O port
		Peripheral function		
Port 4	P40/SEG14 to P47/SEG21	General purpose I/O port		
		Peripheral function		
Port 5	P50/INT0 to P57/SGA	General purpose I/O port		
		Peripheral function		
Port 6	P60/AN0 to P67/AN7	Analog CMOS (hysteresis) (Automotive level*)	General purpose I/O port	
		Peripheral function		
Port 7	P70/PWM1P0 to P77/PWM2M1	CMOS (hysteresis) (Automotive level*)	General purpose I/O port	
			Peripheral function	
Port 8	P80/PWM1P2 to P87/PWM2M3		General purpose I/O port	
			Peripheral function	
Port 9	P90/SEG22, P91/SEG23	General purpose I/O port		
		Peripheral function		

(Continued)

MB90420G/425G Series

(Continued)

Port	bit7	bit6	bit5	bit4	bit3	bit2	bit1	bit0
Port 0	P07	P06	P05	P04	P03	P02	P01	P00
	PPG1	PPG0	SCK1	SOT1	SIN1	SCK0	SOT0	SIN0
	TIN1	TOT1	—	—	INT7	INT6	INT5	INT4
Port 1	—	—	P15	P14	P13	P12	P11	P10
	—	—	IN0	IN1	IN2	IN3	WOT	PPG2
	—	—	—	—	—	TIN0	TOT0	—
Port 3	P37	P36	—	—	—	—	—	—
	SEG13	SEG12	—	—	—	—	—	—
Port 4	P47	P46	P45	P44	P43	P42	P41	P40
	SEG21	SEG20	SEG19	SEG18	SEG17	SEG16	SEG15	SEG14
Port 5	P57	P56	P55	P54	P53	P52	P51	P50
	SGA	SGO	RX0	TX0	INT3	INT2	INT1	INT0
	—	FRCK	—	—	—	TX1	RX1	—
Port 6	P67	P66	P65	P64	P63	P62	P61	P60
	AN7	AN6	AN5	AN4	AN3	AN2	AN1	AN0
Port 7	P77	P76	P75	P74	P73	P72	P71	P70
	PWM2M1	PWM2P1	PWM1M1	PWM1P1	PWM2M0	PWM2P0	PWM1M0	PWM1P0
Port 8	P87	P86	P85	P84	P83	P82	P81	P80
	PWM2M3	PWM2P3	PWM1M3	PWM1P3	PWM2M2	PWM2P2	PWM1M2	PWM1P2
Port 9	—	—	—	—	—	—	P91	P90
	—	—	—	—	—	—	SEG23	SEG22

*: Range of input voltage.

For ratings see “3. DC Characteristics” in “■ ELECTRICAL CHARACTERISTICS”.

Note : Port 6 also functions as an analog input pin. When using this port as a general purpose port, always write “0” to the corresponding analog input enable register (ADER) bit. The ADER bit is initialized to “1” at reset.

(2) Block Diagrams

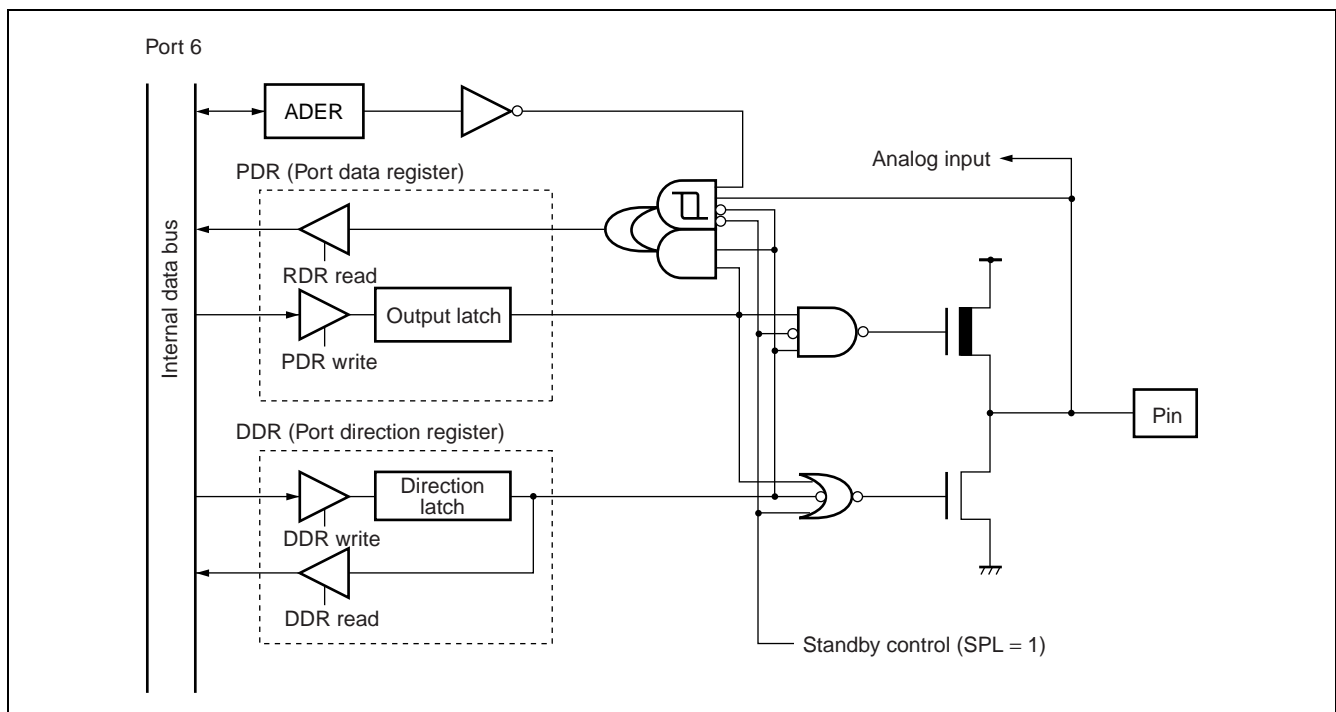
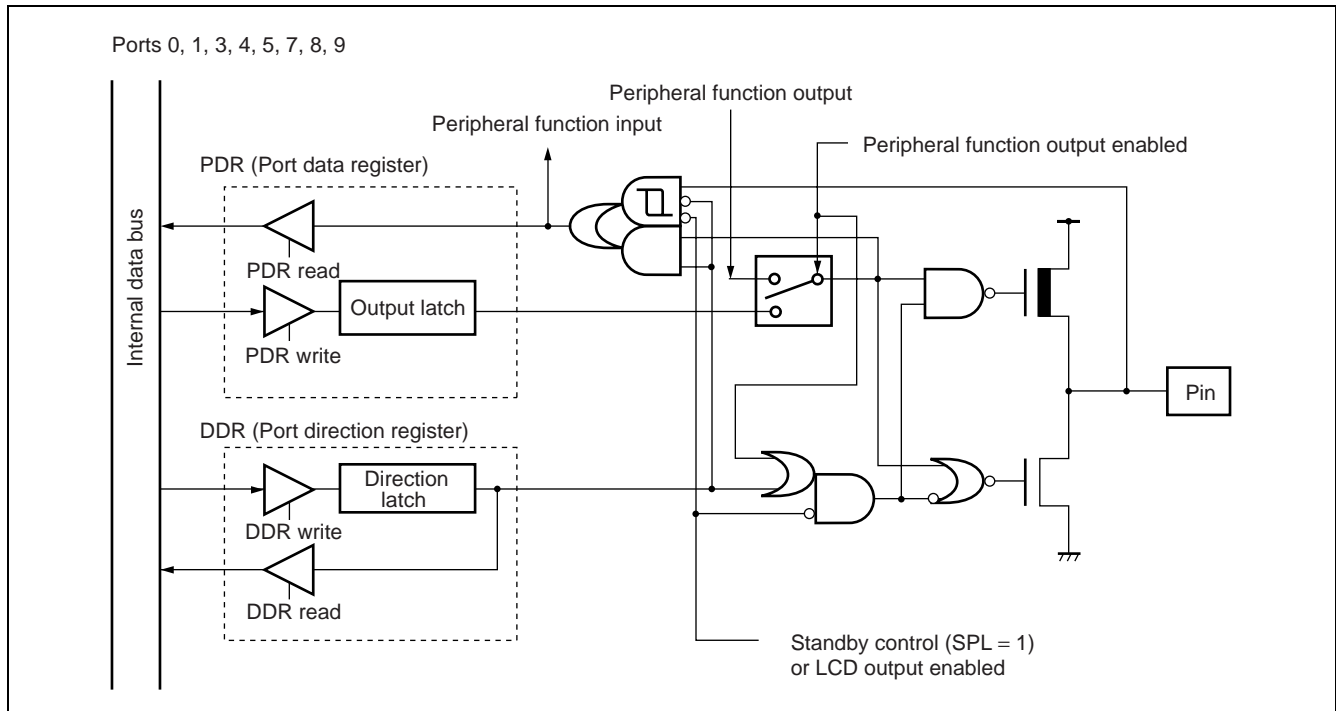

2. Watchdog Timer/Time Base Timer/Watch Timer

The watchdog timer, timer base timer, and watch timer have the following circuit configuration.

- Watchdog timer : Watchdog counter, control register, watchdog reset circuit
- Time base timer : 18-bit timer, interval interrupt control circuit
- Watch timer : 15-bit timer, interval interrupt control circuit

(1) Watchdog timer function

The watchdog timer is composed of a 2-bit watchdog counter that uses the carry signal from the 18-bit time base timer or 15-bit watch timer as a clock source, plus a control register and watchdog reset control circuit.

After startup, this function will reset the CPU if not cleared within a given time.

(2) Time base timer function

The time base timer is an 18-bit free-run counter (time base counter) synchronized with the internal count clock (base oscillator divided by 2) , with an interval timer function providing a selection of four interval times. Other functions include a timer output for an oscillator stabilization wait time and clock feed to the watchdog timer or other operating clocks. Note that the time base timer uses the main clock regardless of the setting of the MCS bit or SCS bit in the CKSCR register.

(3) Watch timer function

The watch timer provides functions including a clock source for the watchdog timer, a sub clock base oscillator stabilization wait timer, and an interval timer to generate an interrupt at fixed intervals. Note that the watch timer uses the sub clock regardless of the setting of the MCS bit or SCS bit in the CKSCR register.

• Block Diagram

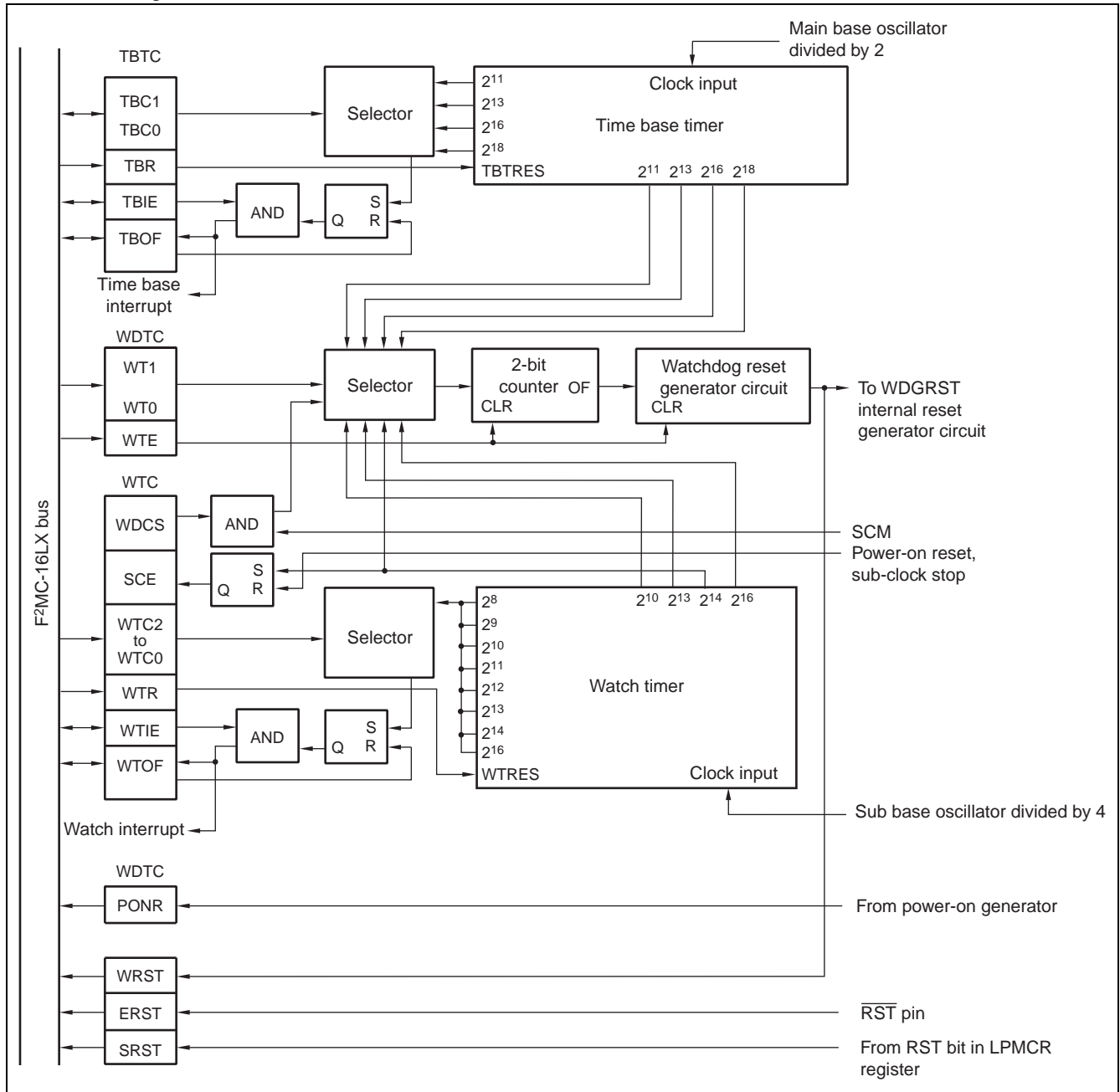

MB90420G/425G Series

3. Input Capture

This circuit is composed of a 16-bit free-run timer and four 16-bit input capture circuits.

(1) Input capture (× 4)

The input capture circuits consist of four independent external input pins and corresponding capture registers and control registers. When the specified edge of the external signal input (at the input pin) is detected, the value of the 16-bit free-run timer is saved in the capture register, and at the same time an interrupt can also be generated.

- The valid edge (rising edge, falling edge, both edges) of the external signal can be selected.
- The four input capture circuits can operate independently.
- The interrupt can be generated from the valid edge of the external input signal.

(2) 16-bit free-run timer (× 1)

The 16-bit free-run timer is composed of a 16-bit up-counter, control register, 16-bit compare register, and prescaler. The output values from this counter are used as the base time for the input capture circuits.

- The counter clock operation can be selected from 8 options. The eight internal clock settings are ϕ , $\phi/2$, $\phi/4$, $\phi/8$, $\phi/16$, $\phi/32$, $\phi/64$, $\phi/128$ where ϕ represents the machine clock cycle.
- Interrupts can be generated from overflow events, or from compare match events with the compare register. (Compare match operation requires a mode setting.)
- The counter value can be initialized to "0000H" by a reset, soft clear, or a compare match with the compare register.

(3) Block diagram

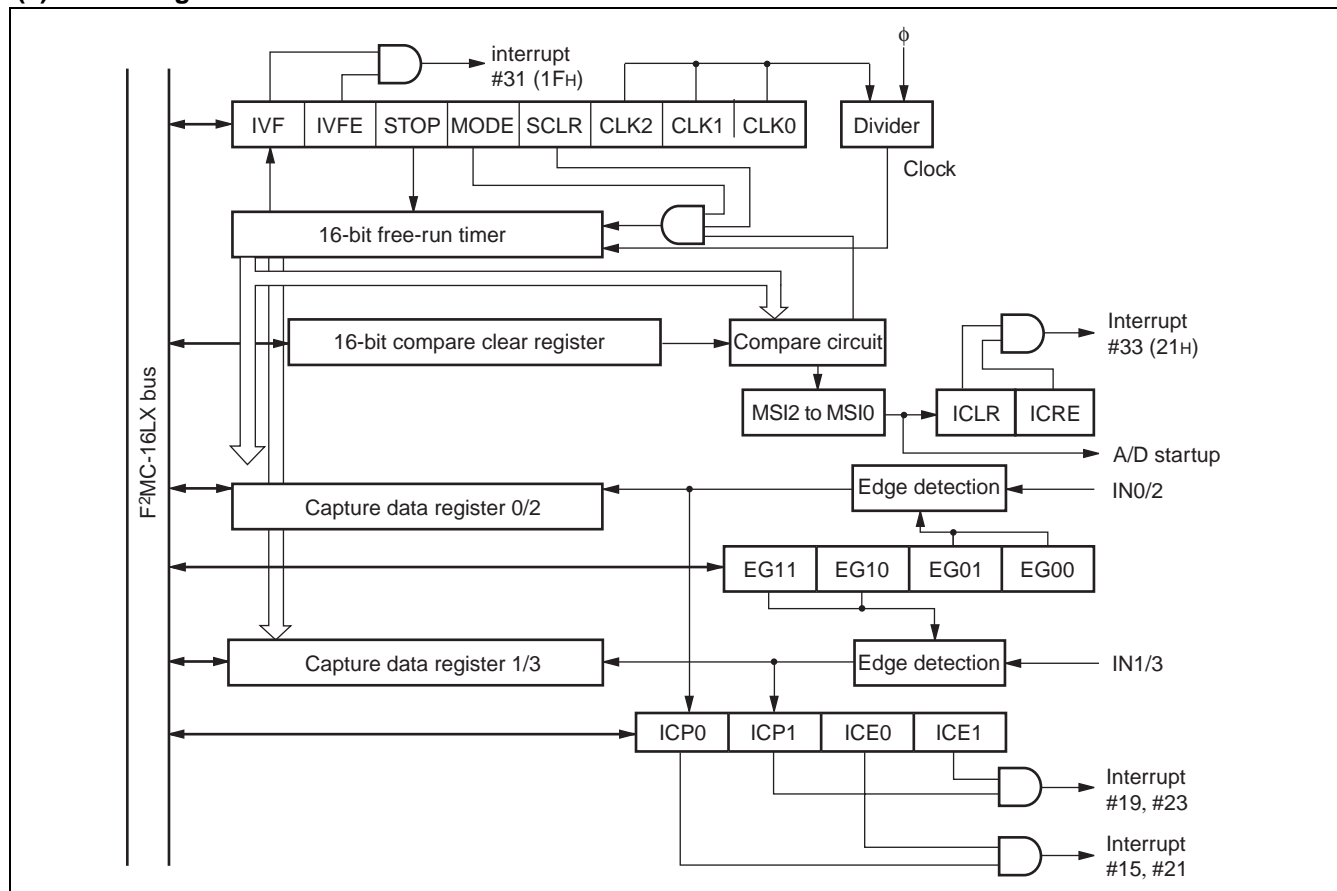

4. 16-bit Reload Timer

The 16-bit reload timer can either count down in synchronization with three types of internal clock signals in internal clock mode, or count down at the detection of the designated edge of an external signal. The user may select either function. This timer defines a transition from 0000_H to FFFF_H as an underflow event. Thus an underflow occurs when counting from the value [Reload register setting + 1].

A selection of two counter operating modes are available. In reload mode, the counter is reset to the count value and continues counting after an underflow, and in one-shot mode the count stops after an underflow. The counter can generate an interrupt when an underflow occurs, and is compatible with the expanded intelligent I/O services (EI²OS) .

(1) 16-bit Reload timer operating modes

Clock mode	Counter mode	16-bit reload timer operation
Internal clock mode	Reload mode	Soft trigger operation External trigger operation External gate input operation
	One-shot mode	
Event count mode (external clock mode)	Reload mode	Soft trigger operation
	One-shot mode	

(2) Internal clock mode

One of three input clocks is selected as the count clock, and can be used in one of the following operations.

- Soft trigger operation
When “1” is written to the TRG bit in the timer control status register (TMCSR0/1) , the count operation starts. Trigger input at the TRG bit is normally valid with an external trigger input, as well as an external gate input.
- External trigger operation
Count operation starts when a selected edge (rising, falling, both edges) is input at the TIN0/1 pin.
- External gate input operation
Counting continues as long as the selected signal level (“L” or “H”) is input at the TIN0/1 pin.

(3) Event count mode (External clock mode)

In this mode a down count event occurs when a selected valid edge (rising, falling, both edges) is input at the TIN0/1 pin. This function can also be used as an interval timer when an external clock with a fixed period is used.

(4) Counter operation

- Reload mode

In down count operation, when an underflow event (transition from “0000_H” to “FFFF_H”) occurs, the set count value is reloaded and count operation continues. The function can be used as an interval timer by generating an interrupt request at each underflow event. Also, a toggle waveform that inverts at each underflow can be output from the TOT0/1 pin.

Counter clock	Counter clock period	Interval time
Internal clock	$2^1/\phi$ (0.125 μ s)	0.125 μ s to 8.192 ms
	$2^3/\phi$ (0.5 μ s)	0.5 μ s to 32.768 ms
	$2^5/\phi$ (2.0 μ s)	2.0 μ s to 131.1 ms
External clock	$2^3/\phi$ or greater (0.5 μ s)	0.5 μ s or greater

ϕ : Machine clock cycle. Figures in () are values at machine clock frequency 16 MHz.

MB90420G/425G Series

(5) One-shot mode

In down count operation, the count stops when an underflow event (transition from "0000H" to "FFFFH") occurs. This function can generate an interrupt at each underflow. While the counter is operating, a rectangular wave form indicating that the count is in progress can be output from the TOT0 and TOT1 pins.

(6) Block diagram

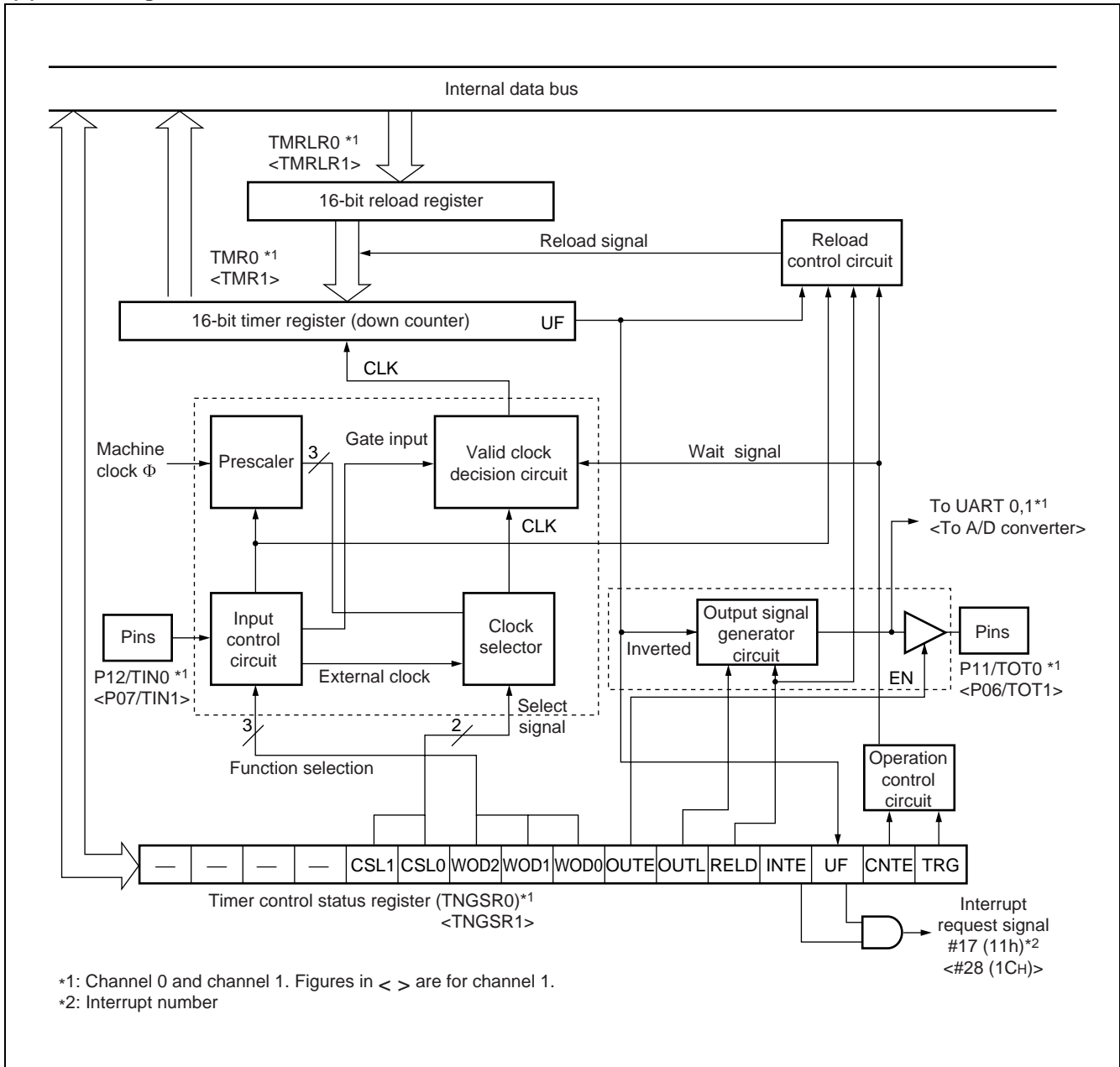

5. Real Time Watch Timer

The real time watch timer is composed of a real time watch timer control register, sub second data register, second/minute/hour data registers, 1/2 clock divider, 21-bit prescaler and second/minute/hour counters. Because the MCU oscillation frequency operates on a given real time watch timer operation, a 4 MHz frequency is assumed. The real time watch timer operates as a real world timer and provides real world time information.

- Block diagram

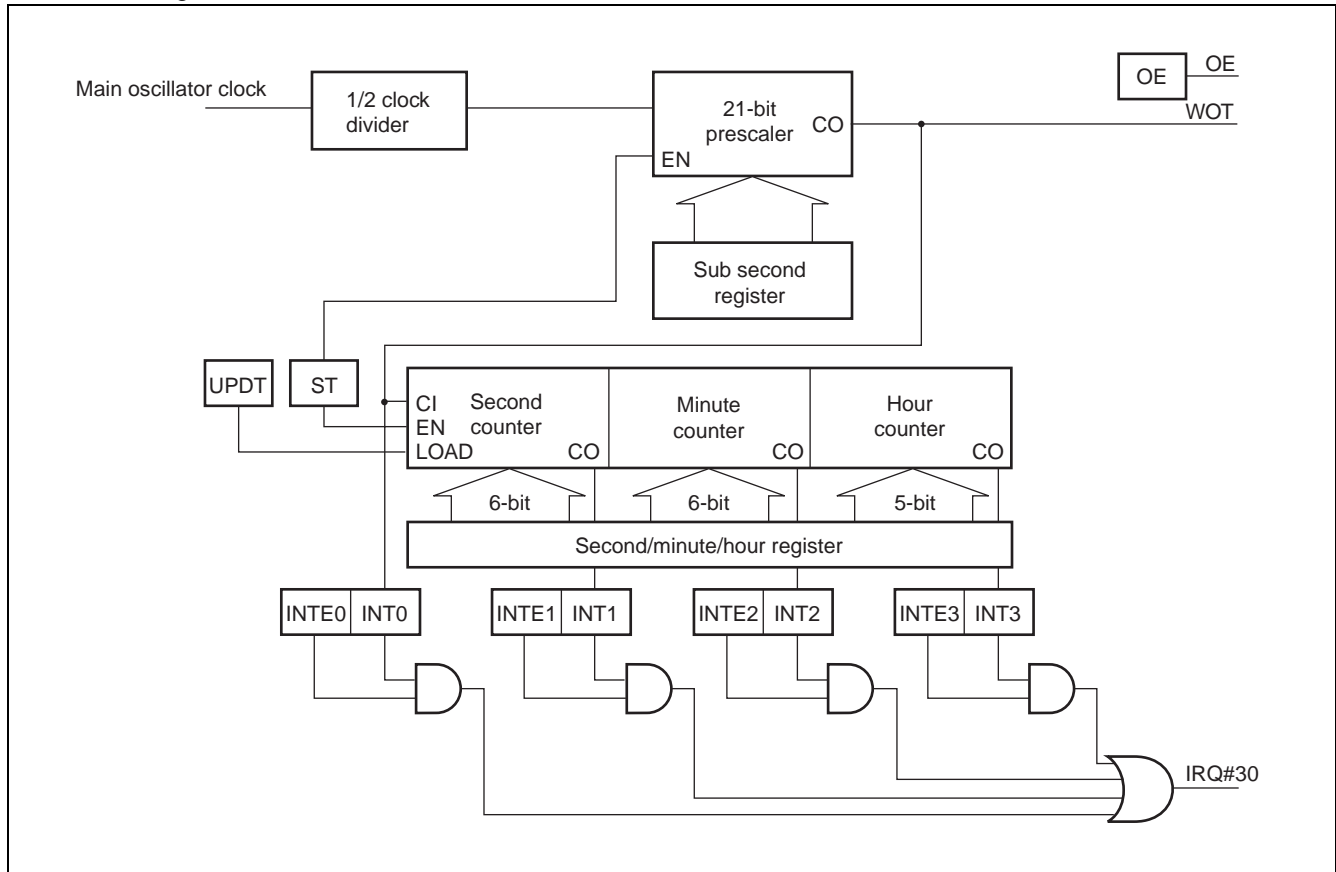

6. PPG Timer

The PPG timer consists of a prescaler, one 16-bit down-counter, 16-bit data register with buffer for period setting, and 16-bit compare register with buffer for duty setting, plus pin control circuits.

The timer can output pulses synchronized with an externally input soft trigger. The period and duty of the output pulse can be adjusted by rewriting the values in the two 16-bit registers.

(1) PWM function

Programmable to output a pulse, synchronized with a trigger.

Can also be used as a D/A converter with an external circuit.

(2) One-shot function

Detects the edge of a trigger input, and outputs a single pulse.

(3) Pin control

- Set to "1" at a duty match (priority) .
- Reset to "0" at a counter borrow event
- Has a fixed output mode to output a simple all "L" (or "H") signal.
- Polarity can be specified

(4) 16-bit down counter

- Select from four types of counter operation clocks. Four internal clocks (ϕ , $\phi/4$, $\phi/16$, $\phi/64$) ϕ : Machine clock cycles.
- The counter value can be initialized to "FFFF_H" at a reset or counter borrow event.

(5) Interrupt requests

- Timer startup
- Counter borrow event (period match)
- Duty match event
- Counter borrow event (period match) or duty match event

(6) Multiple channels can be set to start up at an external trigger, or to restart during operation.

(7) Block diagram

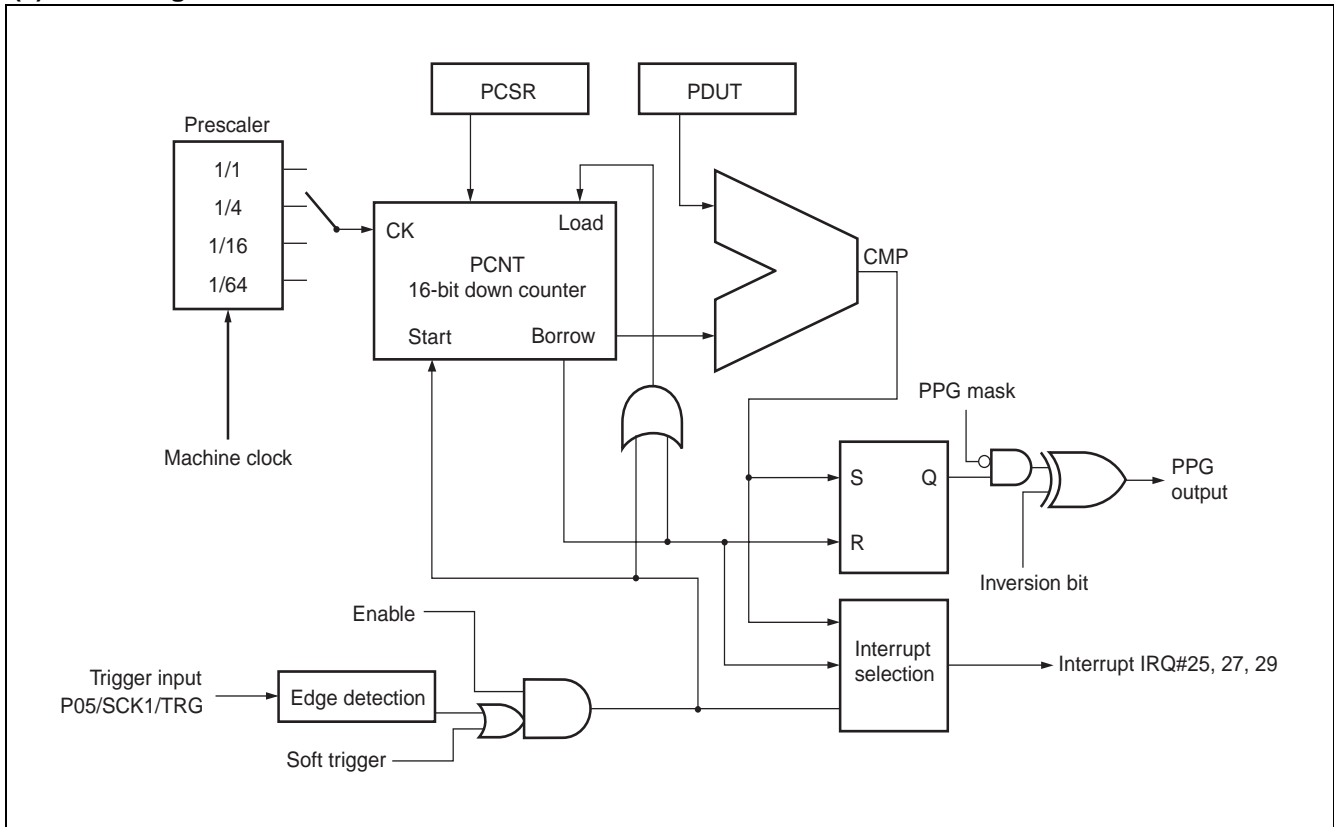

7. Delayed Interrupt Generator Module

The delayed interrupt generator module is a module that generates interrupts for task switching. This module makes it possible to use software to generate/cancel interrupt requests to the F²MC-16LX CPU.

- Block diagram

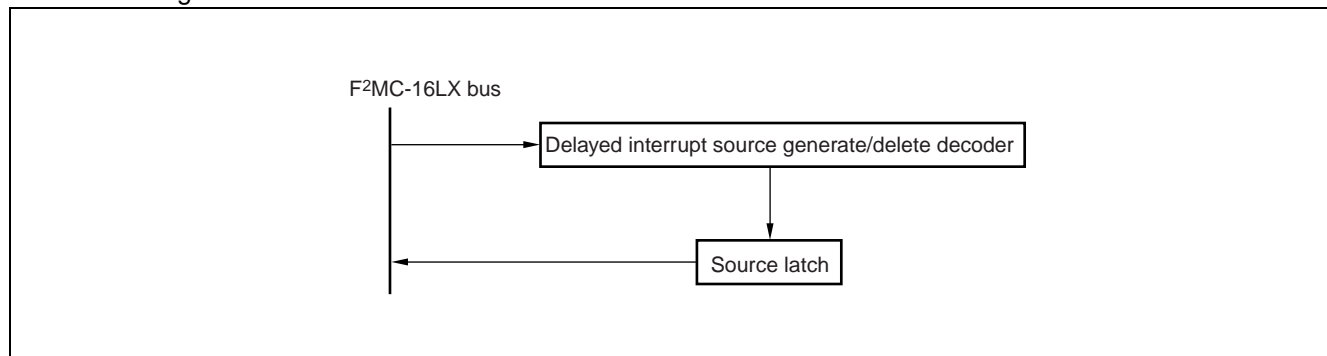

8. DTP/External Interrupt Circuit

The DTP (Data transfer peripheral) /external interrupt circuit is located between an externally connected peripheral device and the F²MC-16LX CPU and sends interrupt requests or data transfer requests generated from the peripheral device to the CPU, thereby generating external interrupt requests or starting the expanded intelligent I/O services (EI²OS) .

(1) DTP/external interrupt function

The DTP/external interrupt function uses a signal input from the DTP/external interrupt pin as a startup source. And it is accepted by the CPU by the same procedure as a normal hardware interrupt, and can generate an external interrupt or start the expanded intelligent I/O service (EI²OS) .

When the interrupt is accepted by the CPU, if the corresponding expanded intelligent I/O service (EI²OS) is prohibited the interrupt operates as an external interrupt function and branches to an interrupt routine. If the EI²OS is permitted the interrupt functions as a DTP function, using EI²OS for automatic data transfer, then branching to an interrupt routine after the completion of the specified number of data transfers.

	External interrupt	DTP function
Input pins	8 pins (P50/INT0/ADTG to P53/INT3, P00/SIN0/INT4 to P03/INT7)	
Interrupt sources	Request level setting register (ELVR) sets the detection level, or selected edge for each pin	
	"H" level/ "L" level/ rising edge/falling edge input	"H" level/ "L" level input
Interrupt numbers	#16 (10 _H) , #18 (12 _H) , #20 (14 _H) , #22 (16 _H) , #24 (18 _H) , #26 (1A _H)	
Interrupt control	DTP/interrupt enable register (ENIR) permits/prohibits interrupt request output	
Interrupt flags	DTP/interrupt enable register (EIRR) stores interrupt sources	
Process selection	When EI ² OS prohibited (ICR : ISE = 0)	When EI ² OS is enabled (ICR : ISE = 1)
Processing	Branch to external interrupt processing routine	EI ² OS performs automatic data transfer, then after a specified number of cycles, branches to an interrupt routine

ICR : Interrupt control register

MB90420G/425G Series

(2) Block diagram

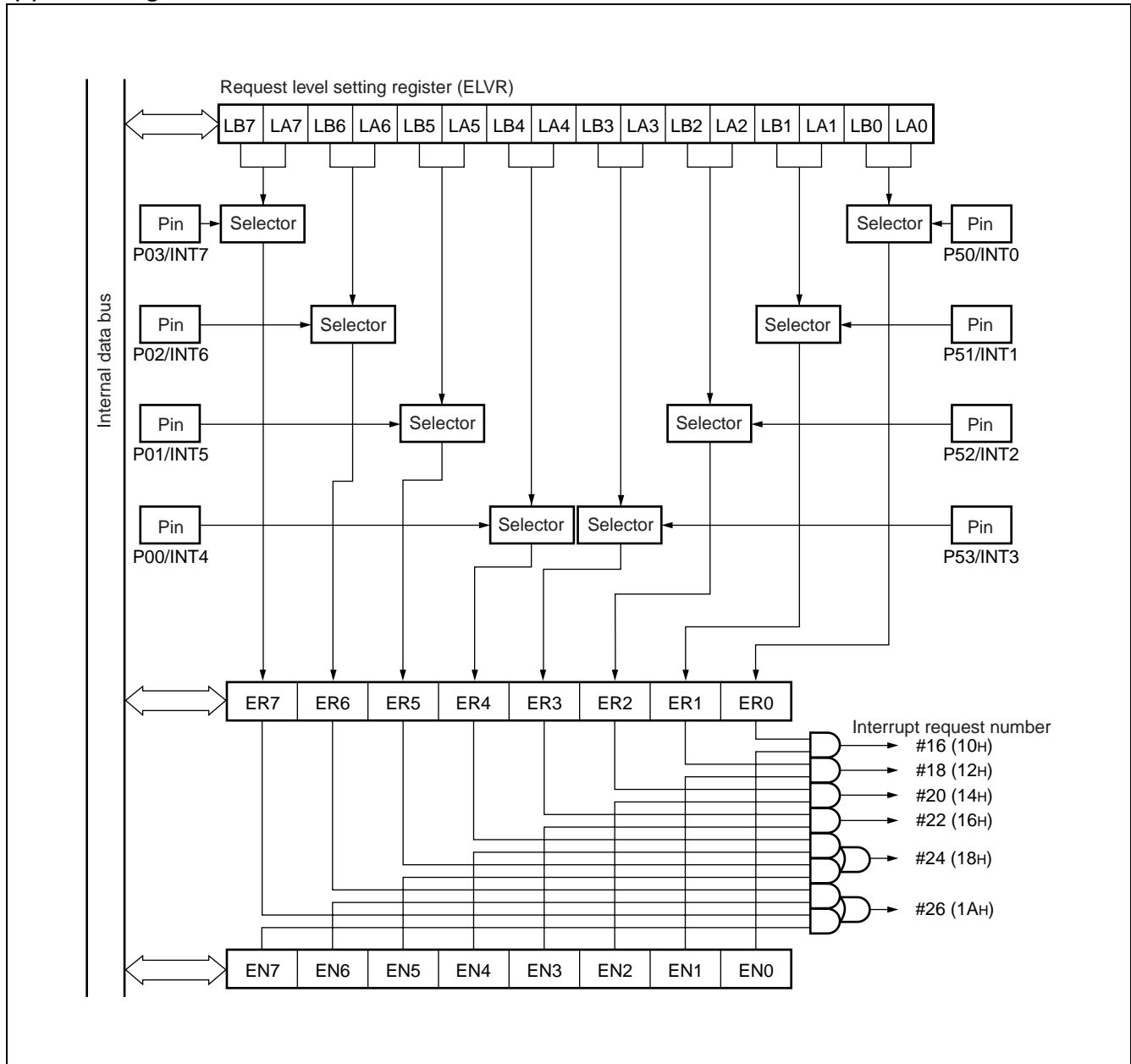

9. 8/10-bit A/D Converter

The 8/10-bit A/D converter has functions for using RC sequential comparator conversion format to convert analog input voltage into 10-bit or 8-bit digital values. The input signal is selected from 8-channel analog input pins, and the conversion start can be selected from three types : by software, 16-bit reload timer 1 or a trigger input from an external signal pin.

(1) 8/10-bit A/D converter functions

The A/D converter takes analog voltage signals (input voltage) input at analog input pins, and converts these to digital values, providing the following features.

- Minimum conversion time is 6.13 μ s (at machine clock frequency of 16 MHz, including sampling time) .
- Minimum sampling time is 3.75 μ s (at machine clock 16 MHz)
- The conversion method is an RC sequential conversion in comparison with a sample hold circuit.
- Either 10-bit or 8-bit resolution can be selected.
- The analog input pin can select from 8 channels by a program setting.
- At completion of A/D conversion, an interrupt request can be generated, or EI²OS can be started.
- Because the conversion data protection function operates in an interrupt enabled state, no data is lost even in continuous conversion.
- The conversion start source may be selected from : software, 16-bit reload timer 1 (rising edge) , or external trigger input (falling edge) .

Three conversion modes are available

Conversion mode	Single conversion operation	Scan conversion operation
Single conversion mode	Converts the specified channel (1 channel only) one time, then stops.	Converts multiple consecutive channels (up to 8 channels may be specified) one time, then stops.
Continuous conversion mode	Converts the specified channel (1 channel only) repeatedly.	Converts multiple consecutive channels (up to 8 channels may be specified) repeatedly.
Stop conversion mode	Converts the specified channel (1 channel only) one time, then pauses, waits until the next start is applied.	Converts multiple consecutive channels (up to 8 channels may be specified) , however pauses after conversion of each channel, waits until the next start is applied.

MB90420G/425G Series

(2) Block diagram

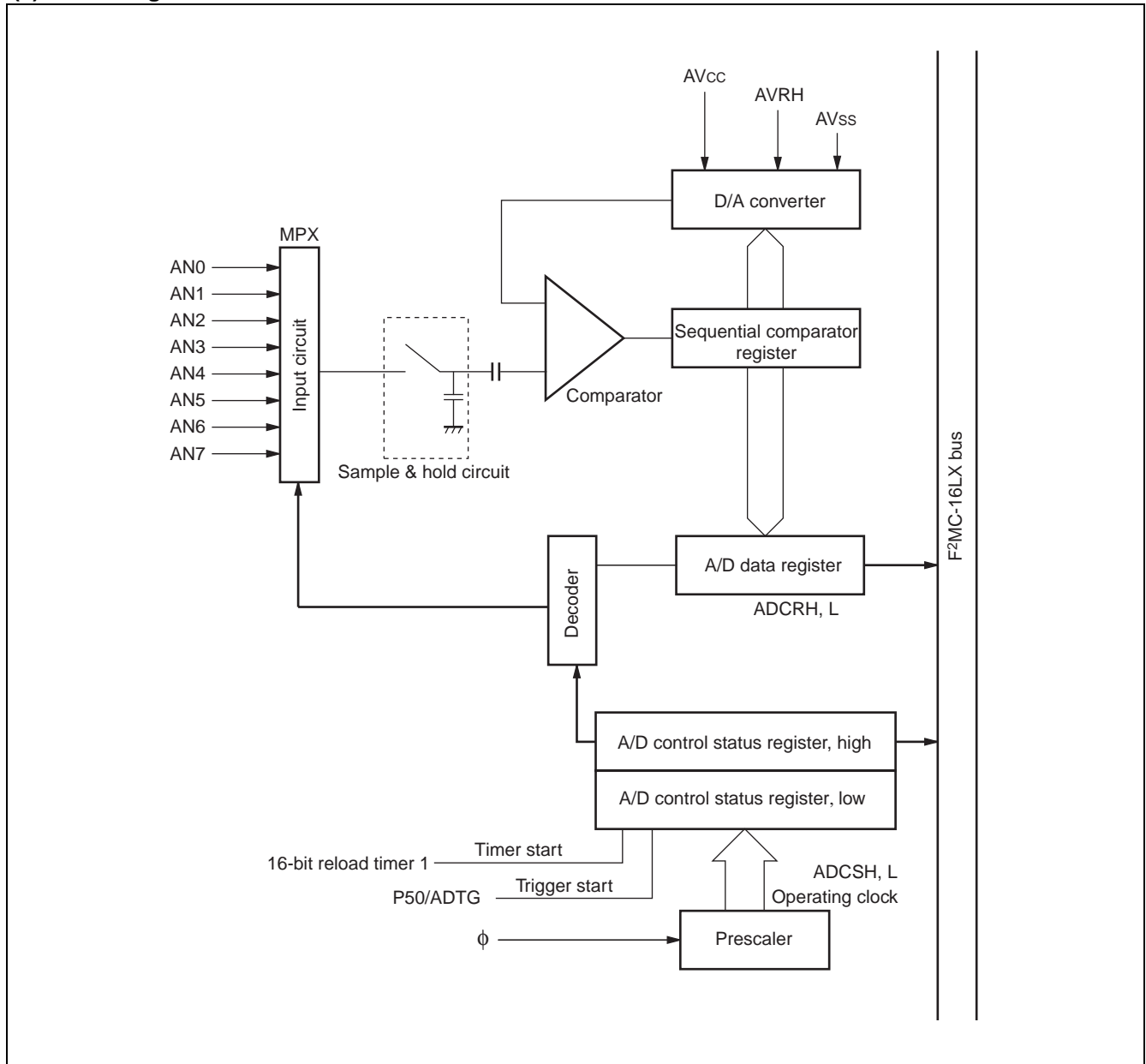

10. UART

The UART is a general purpose serial data communication interface for synchronous communication, or asynchronous (start-stop synchronized) communication with external devices. Functions include normal bi-directional functions, as well as master/slave type communication functions (multi-processor mode : master side only supported) .

(1) UART Functions

The UART is a general purpose serial data communication interface for sending and receiving of serial data with other CPU's or peripheral devices, and provides the following functions.

	Functions
Data buffer	Full duplex double buffer
Transfer modes	<ul style="list-style-type: none"> • Clock synchronous (no start/stop bits) • Clock asynchronous (start-stop synchronized)
Baud rate	<ul style="list-style-type: none"> • Exclusive baud rate generator provides a selection of 8 rates • External clock input enabled • Internal clock (can use internal clock feed from 16-bit reload timer)
Data length	<ul style="list-style-type: none"> • 7-bit (asynchronous normal mode only) • 8-bit
Signal type	NRZ (Non return to zero)
Receiving error detection	<ul style="list-style-type: none"> • Framing errors • Overrun errors • Parity errors (not enabled in multiprocessor mode)
Interrupt request	<ul style="list-style-type: none"> • Receiving interrupt (receiving completed, receiving error detection) • Sending interrupt (sending completed) • Sending/receiving both compatible with expanded intelligent I/O services (EI²OS)
Master/slave type communication function (multi-processor mode)	1 (master) -to-n (slave) communication enabled (only master side supported) .

Note : The UART in clock synchronous transfer does not add start bits or stop bits, but transfers data only.

Operating mode		Data length		Synchronization	Stop bit length
		No parity	Parity		
0	Normal mode	7-bit or 8-bit		Asynchronous	1-bit or 2-bit *2
1	Multi-processor mode	8 + 1 *1	—	Asynchronous	
2	Normal mode	8	—	Synchronous	None

— : Setting not available

*1 : “+” indicates an address/data selection bit (A/D) for communication control.

*2 : In receiving only one stop bit is detected.

MB90420G/425G Series

(2) Block diagram

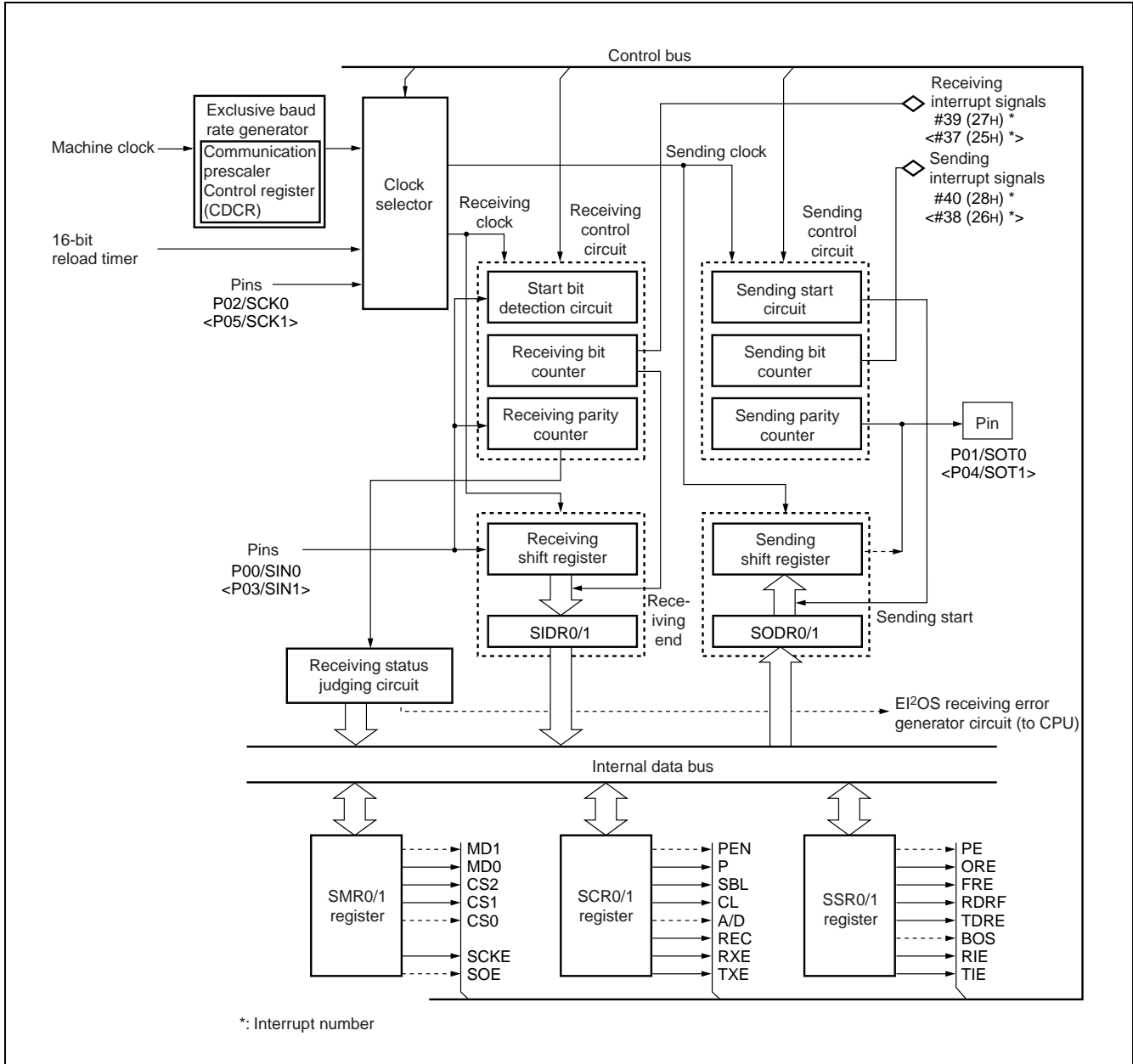

11. CAN Controller

The CAN controller is a self-contained module within a 16-bit microcomputer (F²MC-16LX) . The CAN (controller area network) controller is the standard protocol for serial transmissions among automotive controllers and is widely used in the industry.

(1) CAN controller features

The CAN controller has the following features.

- Conforms to CAN specifications version 2.0 A and B.
 - Supports sending and receiving in standard frame and expanded frame format.
- Supports data frame sending by means of remote frame receiving.
- 16 sending/receiving message buffers
 - 29-bit ID and 8-byte data
 - Multi-level message buffer configuration
- Supports full bit compare, full bit mask as well as partial bit mask filtering.
 - Provides two receiving mask registers for either standard frame or expanded frame format.
- Bit speed programmable from 10 KB/s to 1 MB/s (at machine clock 16 MHz)
- CAN WAKE UP function
- The MB90420G series has a two-channel built-in CAN controller. The MB90425G series has a 1-channel built-in CAN controller.

MB90420G/425G Series

(2) Block diagram

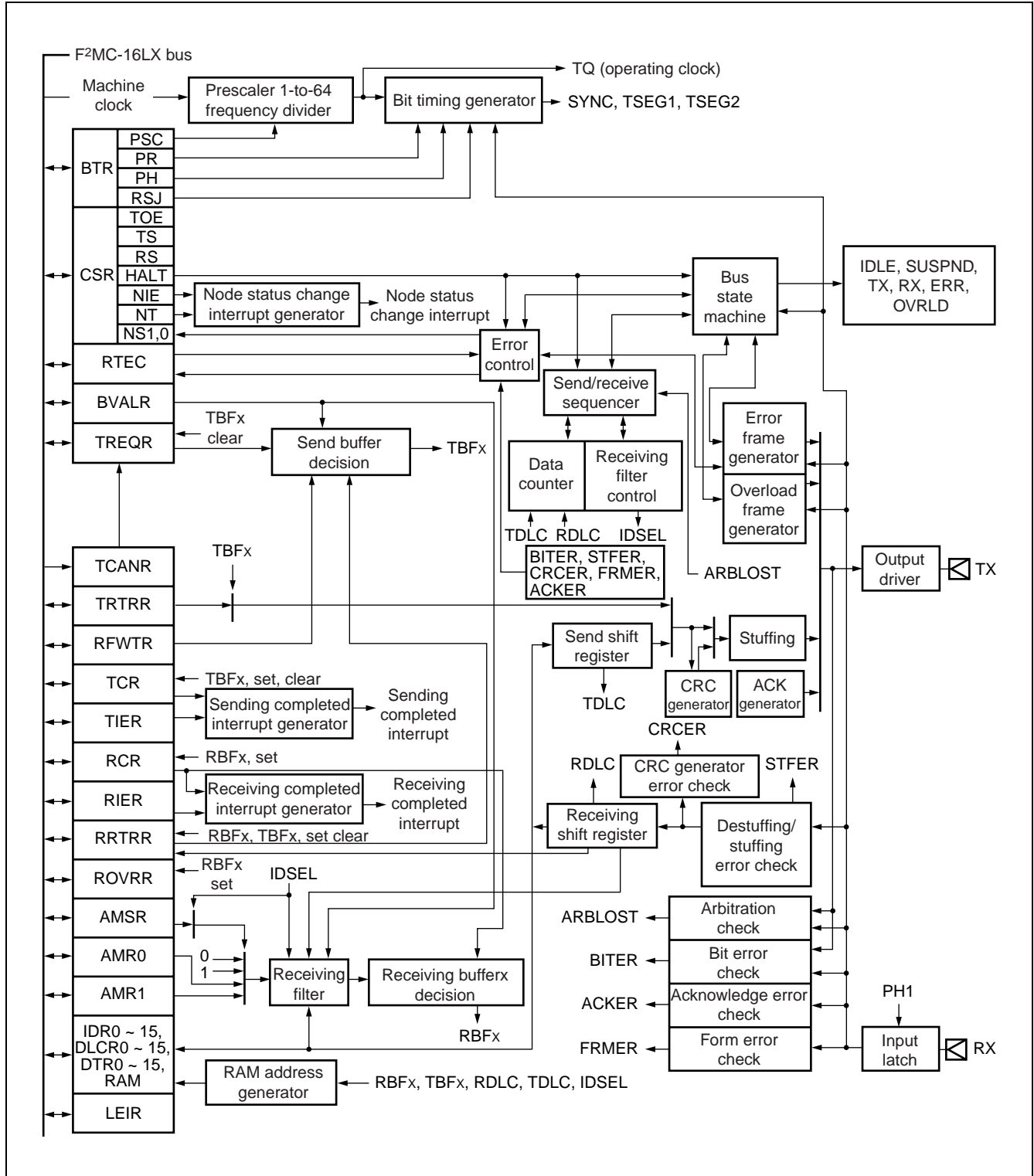

12. LCD Controller/Driver

The LCD controller/driver has a built-in 16×8 -bit display data memory, and controls the LCD display by means of four common outputs and 24 segment outputs. A selection of three duty outputs are available. This block can drive an LCD (liquid crystal display) panel directly.

(1) LCD controller/driver functions

The LCD controller/driver provides functions for directly displaying the contents of display data memory (display RAM) on the LCD panel by means of segment output and common output.

- LCD drive voltage divider resistance is built-in. External divider resistance can also be connected.
- Up to 4 common outputs (COM0 to COM3) and 24 segment outputs (SEG0 to SEG23) can be used.
- 16-byte display data memory (display RAM) is built-in.
- The duty can be selected at 1/2, 1/3, 1/4 (limited by bias setting) .
- Drives the LCD directly.

Bias	1/2 duty	1/3 duty	1/4 duty
1/2 bias	○	×	×
1/3 bias	×	○	○

○ : Recommended mode

× : Use prohibited

Note : When the SEG12 to SEG23 pins have been selected as general purpose ports by the LCRH setting, they cannot be used for segment output.

MB90420G/425G Series

(2) Block diagram

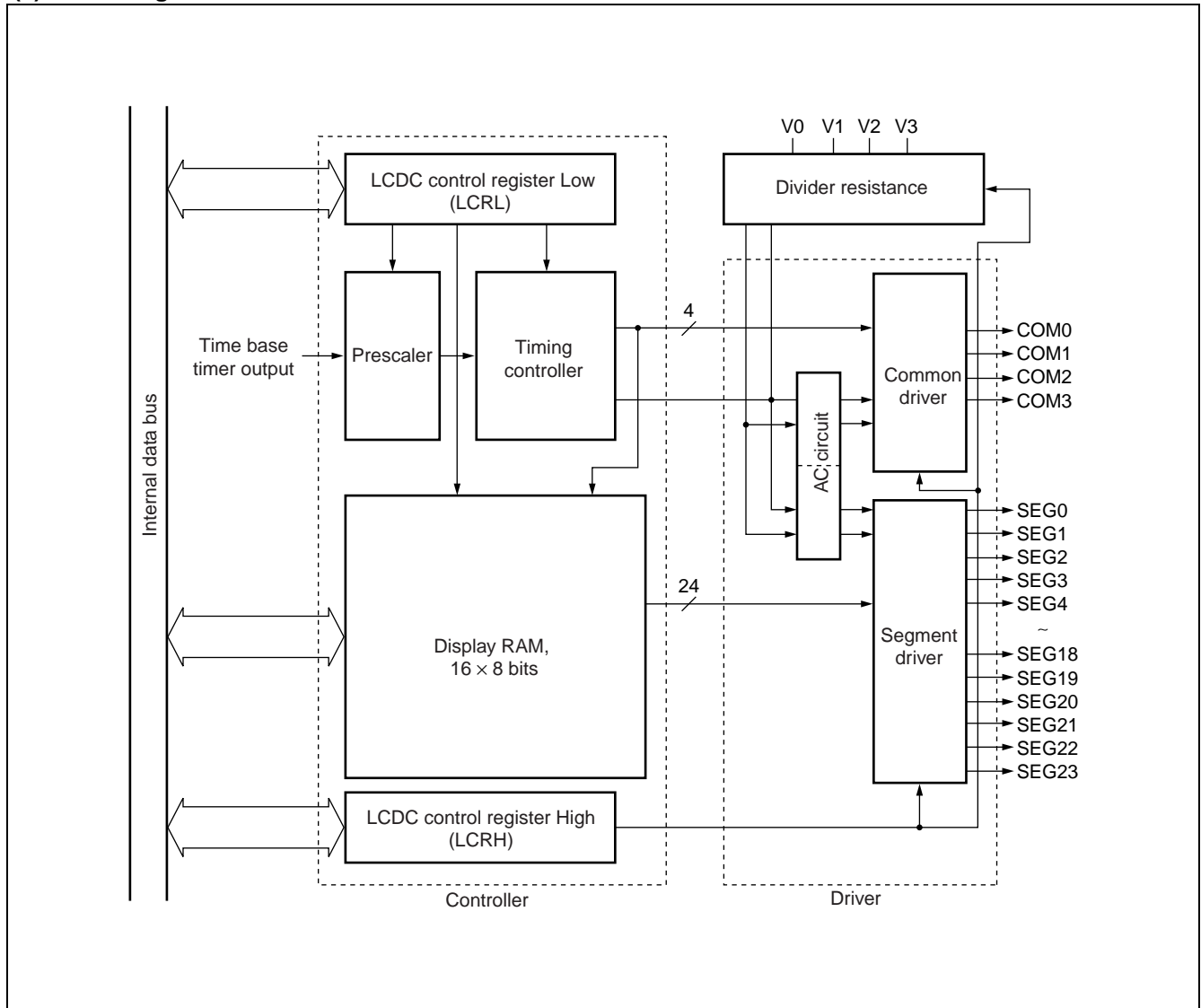

13. Low voltage/Program Looping Detection Reset Circuit

The Low voltage detection reset circuit is a function that monitors power supply voltage in order to detect when a voltage drops below a given voltage level. When a low voltage condition is detected, an internal reset signal is generated.

The Program Looping detection reset circuit is a count clock with a 20-bit counter that generates an internal reset signal if not cleared within a given time after startup.

(1) Low voltage detection reset circuit

Detection voltage
4.0 V \pm 0.3 V

When a low voltage condition is detected, the low voltage detection flag (LVRC : LVRF) is set to "1" and an internal reset signal is output.

Because the low voltage detection circuit continues to operate even in stop mode, detection of a low voltage condition generates an internal reset and releases stop mode.

During an internal RAM write cycle, an internal reset is generated after the completion of writing. During the output of this internal reset, the reset output from the low voltage detection circuit is suppressed.

(2) Program Looping detection reset circuit

The Program Looping detection reset circuit is a counter that prevents program looping. The counter starts automatically after a power-on reset, and must be continually cleared within a given time. If the given time interval elapses and the counter has not been cleared, a cause such as infinite program looping is assumed and an internal reset signal is generated. The internal reset generated from the Program Looping detection circuit has a width of 5 machine cycles.

Interval duration
$2^{20}/F_c$ (Approx. 262 ms *)

* : This value assumes an oscillation clock waveform of 4 MHz.

During recovery from standby mode the detection period is the maximum interval plus 20 μ s.

This circuit does not operate in modes where CPU operation is stopped.

The Program Looping detection reset circuit counter is cleared under any of the following conditions.

1. Writing "0" to the LVRC register CL bit
2. Internal reset
3. Main oscillation clock stop
4. Transition to sleep mode
5. Transition to time base timer mode or watch mode

MB90420G/425G Series

(3) Block diagram

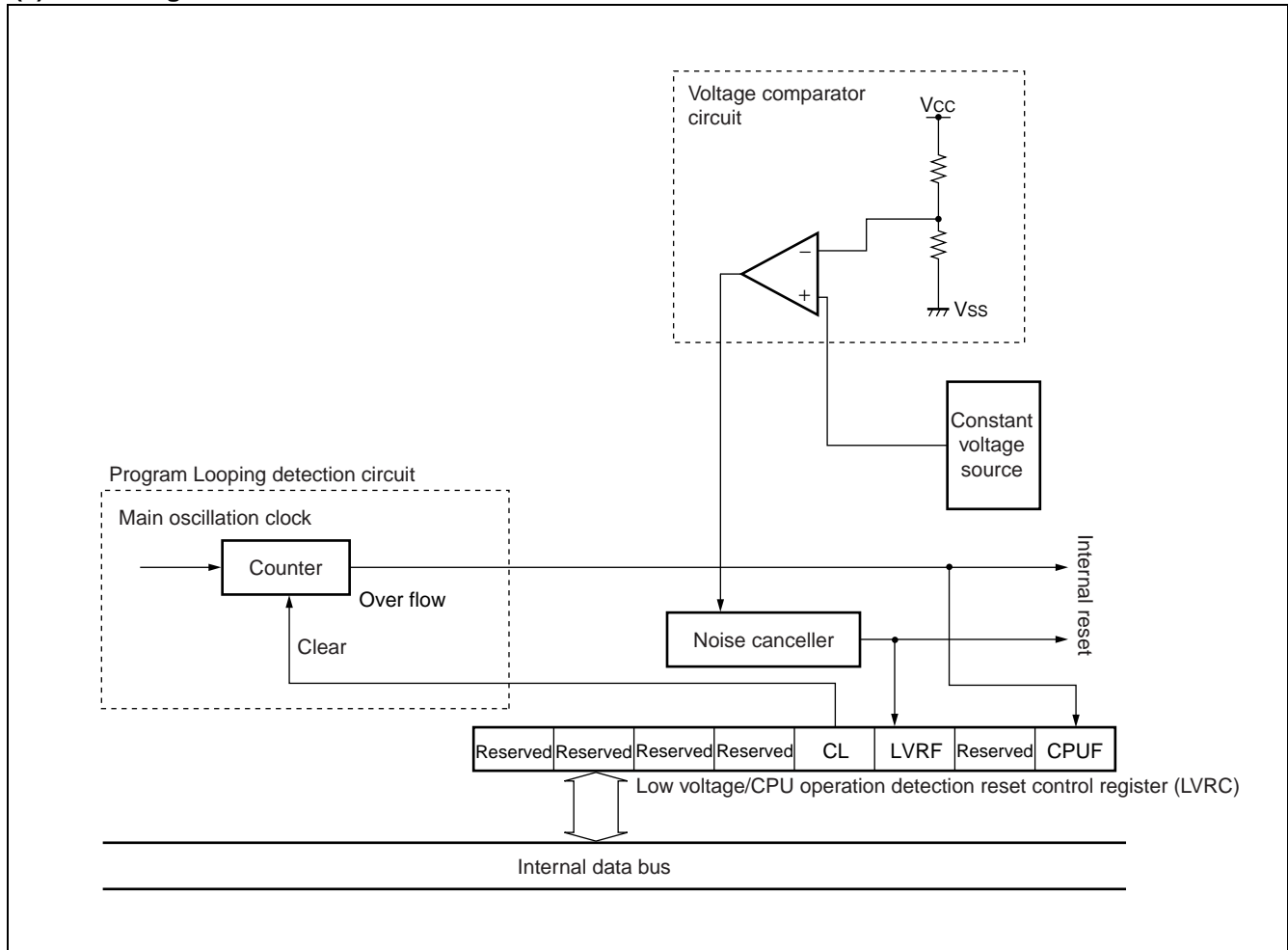

16. Address Match Detect Function

If the address setting is the same as the address detection register, an INT9 instruction is executed. The integrated address match detection function can be implemented by processing the INT9 interrupt service routine.

Two address registers are used, each with its own compare enable bit. When there is a match between the address register and program counter, and the compare enable bit is set to "1", the INT9 instruction is forcibly executed by the CPU.

- Block diagram

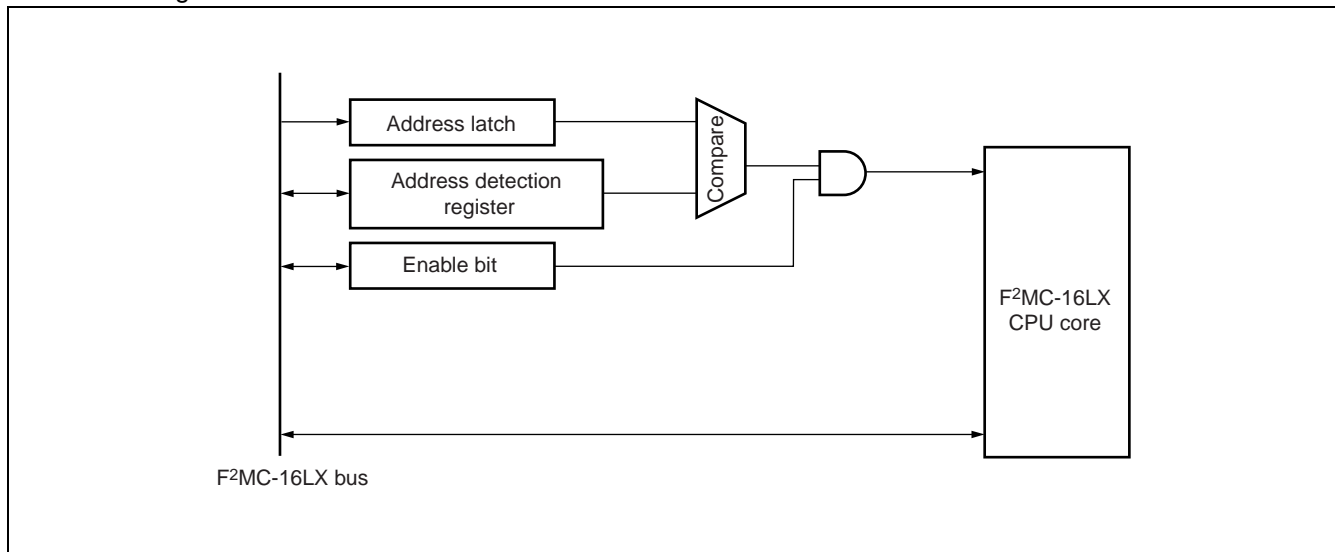

17. ROM Mirror Function Select Module

The ROM mirror function select module uses a select register setting to enable the contents of ROM allocated to the FF bank to be viewed in the 00 bank.

- Block diagram

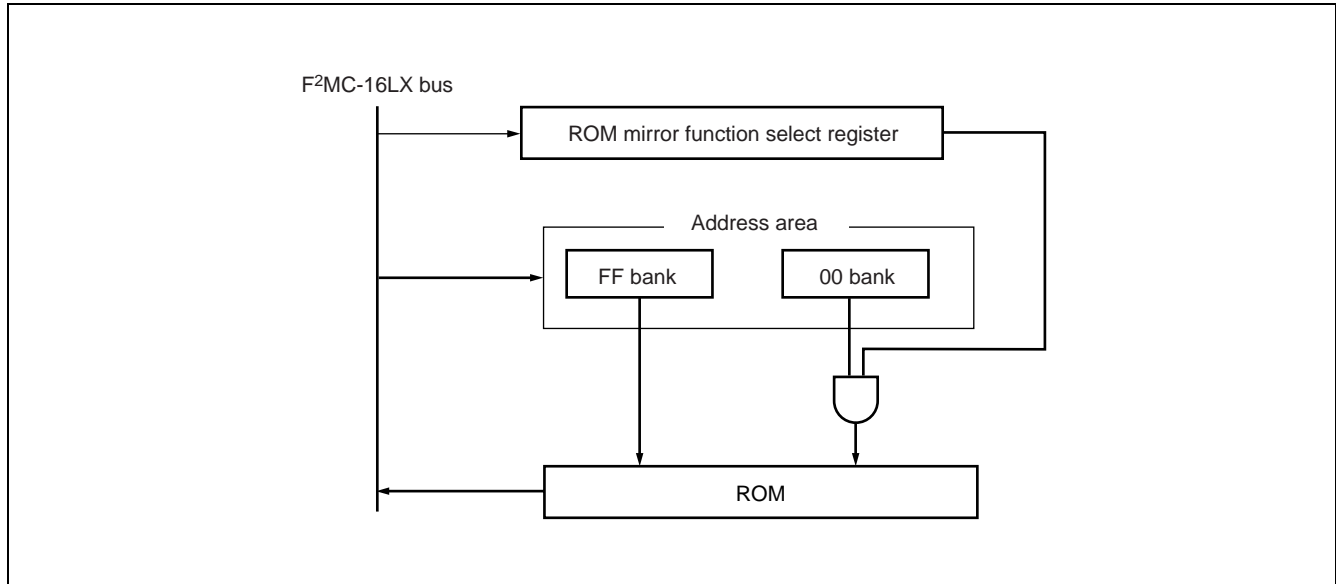

■ ELECTRICAL CHARACTERISTICS

1. Absolute Maximum Ratings

Parameter	Symbol	Rating		Unit	Remarks
		Min	Max		
Power supply voltage*1	V _{CC}	V _{SS} - 0.3	V _{SS} + 6.0	V	
	AV _{CC}	V _{SS} - 0.3	V _{SS} + 6.0	V	AV _{CC} = V _{CC} *2
	AV _{RH}	V _{SS} - 0.3	V _{SS} + 6.0	V	AV _{CC} ≥ AV _{RH} *2
	DV _{CC}	V _{SS} - 0.3	V _{SS} + 6.0	V	DV _{CC} = V _{CC} *2
Input voltage*1	V _I	V _{SS} - 0.3	V _{CC} + 0.3	V	*3
Output voltage*1	V _O	V _{SS} - 0.3	V _{CC} + 0.3	V	
Maximum clamp current	I _{CLAMP}	- 400	+ 400	μA	*7
Total maximum clamp current	Σ I _{CLAMP}	—	4	mA	*7
“L”level maximum output current*4	I _{OL1}	—	15	mA	Other than P70 to P77, and P80 to P87
	I _{OL2}	—	40	mA	P70 to P77, P80 to P87
“L”level average output current*5	I _{OLAV1}	—	4	mA	Other than P70 to P77, and P80 to P87
	I _{OLAV2}	—	30	mA	P70 to P77, P80 to P87
“L”level maximum total output current	Σ I _{OL1}	—	100	mA	Other than P70 to P77, and P80 to P87
	Σ I _{OL2}	—	330	mA	P70 to P77, P80 to P87
“L”level average total output current	Σ I _{OLAV1}	—	50	mA	Other than P70 to P77, and P80 to P87
	Σ I _{OLAV2}	—	250	mA	P70 to P77, P80 to P87
“H”level maximum output current	I _{OH1} *4	—	- 15	mA	Other than P70 to P77, and P80 to P87
	I _{OH2} *4	—	- 40	mA	P70 to P77, P80 to P87
“H”level average output current	I _{OHAV1} *5	—	- 4	mA	Other than P70 to P77, and P80 to P87
	I _{OHAV2} *5	—	- 30	mA	P70 to P77, P80 to P87
“H”level maximum total output current	Σ I _{OH1}	—	- 100	mA	Other than P70 to P77, and P80 to P87
	Σ I _{OH2}	—	- 330	mA	P70 to P77, and P80 to P87
“H”level average total output current	Σ I _{OHAV1} *6	—	- 50	mA	Other than P70 to P77, and P80 to P87
	Σ I _{OHAV2} *6	—	- 250	mA	P70 to P77, P80 to P87
Power consumption	P _D	—	500	mW	
Operating temperature	T _A	- 40	+ 105	°C	
Storage temperature	T _{STG}	- 55	+ 150	°C	

*1 : The parameter is based on V_{SS} = AV_{SS} = DV_{SS} = 0.0 V.

*2 : AV_{CC}, AV_{RH} and DV_{CC} shall never exceed V_{CC}.
Also, AV_{RH} shall never exceed AV_{CC}.

*3 : The maximum current to/from input is limited by some means with external components, the I_{CLAMP} rating supersedes the V_I rating.

*4 : Maximum output current is defined as the peak value of the current of any one of the corresponding pins.

*5 : Average output current is defined as the value of the average current flowing over 100 ms at any one of the corresponding pins. The “average value” can be calculated from the formula of “operating current” times “operating factor”.

(Continued)

MB90420G/425G Series

(Continued)

- *6 : Average total output current is defined as the value of the average current flowing over 100 ms at all of the corresponding pins. The “average value” can be calculated from the formula of “operating current” times “operating factor”.
- *7 :
 - Applicable to pins : P00 to P07, P10 to P15, P50 to P57, P70 to P77, P80 to P87
 - Use within recommended operating conditions.
 - Use at DC voltage (current) .
 - The + B signal should always be applied with a limiting resistance placed between the + B signal and the microcontroller.
 - The value of the limiting resistance should be set so that when the + B signal is applied the input current to the microcontroller pin does not exceed rated values, either instantaneously or for prolonged periods.
 - Note that when the microcontroller drive current is low, such as in the power saving modes, the + B input potential may pass through the protective diode and increase the potential at the V_{CC} pin, and this may affect other devices.
 - Note that if a + B signal is input when the microcontroller current is off (not fixed at 0 V) , the power supply is provided from the pins, so that incomplete operation may result.
 - Note that if the + B input is applied during power-on, the power supply is provided from the pins and the resulting supply voltage may not be sufficient to operate the power-on reset.
 - Care must be taken not to leave the + B input pin open.
 - Note that analog system input/output pins (LCD drive pins, comparator input pins, etc.) cannot accept + B signal input.
 - Sample recommended circuits :

- Input/Output equivalent circuits

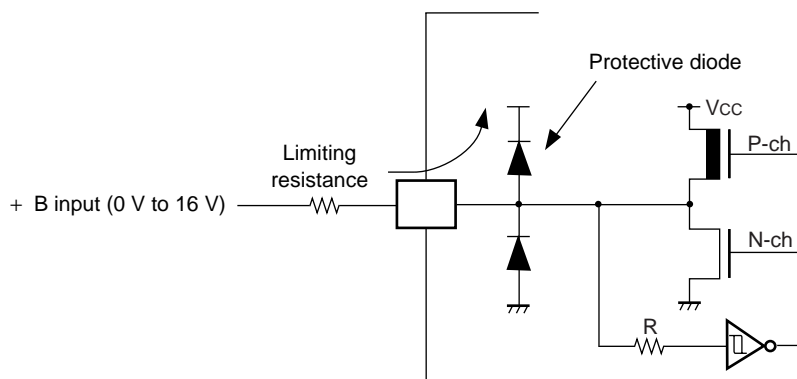

WARNING: Semiconductor devices can be permanently damaged by application of stress (voltage, current, temperature, etc.) in excess of absolute maximum ratings. Do not exceed these ratings.

MB90420G/425G Series

2. Recommended Operating Conditions

($V_{SS} = DV_{SS} = AV_{SS} = 0.0\text{ V}$)

Parameter	Symbol	Value		Unit	Remarks
		Min	Max		
Power supply voltage	V_{CC} AV_{CC} DV_{CC}	3.7	5.5	V	(MB90F428GA, MB90F423GA, MB90428GA, MB90427GA, MB90423GA) Low voltage detection reset starts to work when power supply voltage is $4.0\text{ V} \pm 0.3\text{ V}$.
		3.0	5.5	V	(MB90F428GC, MB90F423GC, MB90428GC, MB90427GC, MB90423GC)
		4.3	5.5	V	Holding stop operation status (MB90F428GA, MB90F423GA, MB90428GA, MB90427GA, MB90423GA)
		3.0	5.5	V	Holding stop operation status (MB90F428GC, MB90F423GC, MB90428GC, MB90427GC, MB90423GC)
Smoothing capacitor*	C_S	0.1	1.0	μF	Use a ceramic capacitor or other capacitor of equivalent frequency characteristics. A bypass capacitor on the V_{CC} pin should have a capacitance greater than C_S .
Operating temperature	T_A	- 40	+ 105	$^{\circ}\text{C}$	

* : For smoothing capacitor C_S connections, see the illustration below.

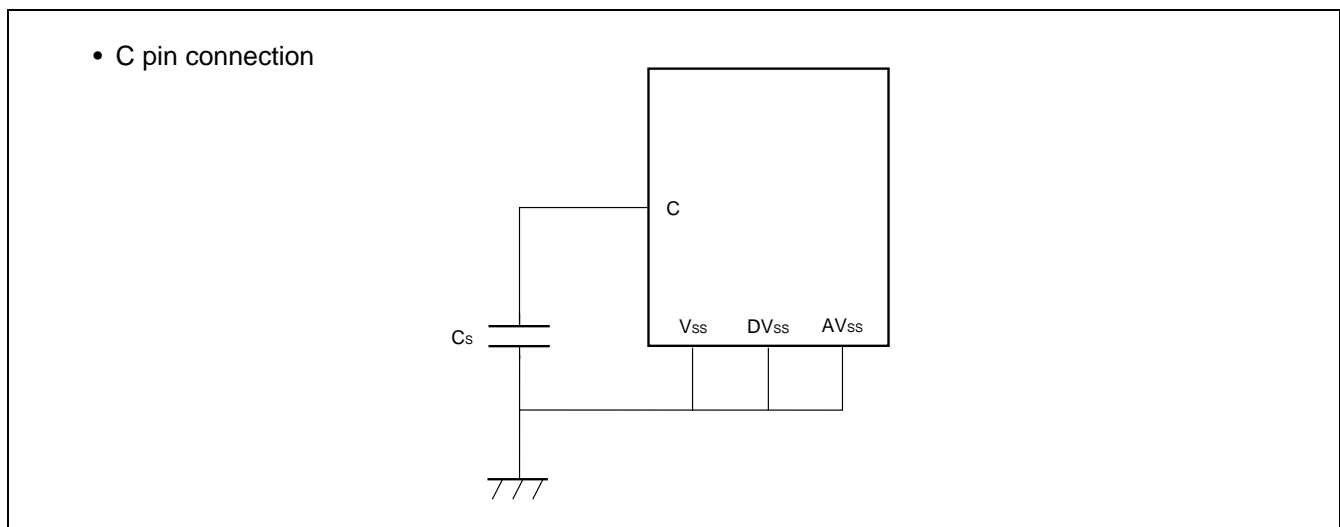

WARNING: The recommended operating conditions are required in order to ensure the normal operation of the semiconductor device. All of the device's electrical characteristics are warranted when the device is operated within these ranges.

Always use semiconductor devices within their recommended operating condition ranges. Operation outside these ranges may adversely affect reliability and could result in device failure.

No warranty is made with respect to uses, operating conditions, or combinations not represented on the data sheet. Users considering application outside the listed conditions are advised to contact their representatives beforehand.

MB90420G/425G Series

3. DC Characteristics

($V_{CC} = 5.0\text{ V} \pm 10\%$, $V_{SS} = DV_{SS} = AV_{SS} = 0.0\text{ V}$, $T_A = -40\text{ }^\circ\text{C}$ to $+105\text{ }^\circ\text{C}$)

Parameter	Symbol	Pin name	Conditions	Value			Unit	Remarks
				Min	Typ	Max		
“H”level input voltage	V_{IHS}	—	—	$0.8 V_{CC}$	—	$V_{CC} + 0.3$	V	CMOS hysteresis Automotive level input pin*1
	V_{IHM}	—	—	$V_{CC} - 0.3$	—	$V_{CC} + 0.3$	V	MD pin*2
“L”level input voltage	V_{ILS}	—	—	$V_{SS} - 0.3$	—	$0.5 V_{CC}$	V	CMOS hysteresis Automotive level input pin*1
	V_{ILM}	—	—	$V_{SS} - 0.3$	—	$V_{SS} + 0.3$	V	MD pin*2
Power supply current*3	I_{CC}	V_{CC}	Operating frequency $F_{CP} = 16\text{ MHz}$, normal operation	—	45	72	mA	MB90F428GA/GC MB90F423GA/GC
				—	38	61	mA	MB90428GA/GC MB90427GA/GC MB90423GA/GC
	I_{CCS}		Operating frequency $F_{CP} = 16\text{ MHz}$, sleep mode	—	15	24	mA	MB90F428GA/GC MB90F423GA/GC
				—	13	21	mA	MB90428GA/GC MB90427GA/GC MB90423GA/GC
	I_{CTS}		Operating frequency $F_{CP} = 2\text{ MHz}$, time base timer mode	—	0.75	1.0	mA	
	I_{CCL}		Operating frequency $F_{CP} = 8\text{ kHz}$, $T_A = +25\text{ }^\circ\text{C}$, subclock operation	—	0.35	0.7	mA	MB90F428GC MB90F423GC MB90428GC MB90427GC MB90423GC
	I_{CCLS}		Operating frequency $F_{CP} = 8\text{ kHz}$, $T_A = +25\text{ }^\circ\text{C}$, sub sleep operation	—	10	30	μA	MB90F428GC MB90F423GC MB90428GC MB90427GC MB90423GC
	I_{CCT}		Operating frequency $F_{CP} = 8\text{ kHz}$, $T_A = +25\text{ }^\circ\text{C}$, watch mode	—	40	100	μA	MB90F428GC MB90F423GC MB90428GC MB90427GC MB90423GC
I_{CCH}	$T_A = +25\text{ }^\circ\text{C}$, stop mode	—	5	20	μA	MB90F428GC MB90F423GC MB90428GC MB90427GC MB90423GC		
		—	40	100	μA	MB90F428GA MB90F423GA MB90428GA MB90427GA MB90423GA		

(Continued)

MB90420G/425G Series

($V_{CC} = 5.0\text{ V} \pm 10\%$, $V_{SS} = DV_{SS} = AV_{SS} = 0.0\text{ V}$, $T_A = -40\text{ }^\circ\text{C}$ to $+105\text{ }^\circ\text{C}$)

Parameter	Symbol	Pin name	Conditions	Value			Unit	Remarks
				Min	Typ	Max		
Input leakage current	I_{IL}	All input pins	$V_{CC} = DV_{CC} = AV_{CC} = 5.5\text{ V}$ $V_{SS} < V_I < V_{CC}$	- 5	—	5	μA	
Input capacitance 1	C_{IN1}	Other than V_{CC} , V_{SS} , DV_{CC} , DV_{SS} , AV_{CC} , AV_{SS} , C, P70 to P77, P80 to P87	—	—	5	15	pF	
Input capacitance 2	C_{IN2}	P70 to P77, P80 to P87	—	—	15	45	pF	
Pull-up resistance	R_{UP}	$\overline{\text{RST}}$, MD0, MD1	—	25	50	100	$\text{k}\Omega$	
Pull-down resistance	R_{DOWN}	MD2	—	25	50	100	$\text{k}\Omega$	
Output H voltage 1	V_{OH1}	Other than P70 to P77, P80 to P87	$V_{CC} = 4.5\text{ V}$ $I_{OH} = -4.0\text{ mA}$	$V_{CC} - 0.5$	—	—	V	
Output H voltage 2	V_{OH2}	P70 to P77, P80 to P87	$V_{CC} = 4.5\text{ V}$ $I_{OH} = -30.0\text{ mA}$	$V_{CC} - 0.5$	—	—	V	
Output L voltage 1	V_{OL1}	Other than P70 to P77, P80 to P87	$V_{CC} = 4.5\text{ V}$ $I_{OL} = 4.0\text{ mA}$	—	—	0.4	V	
Output L voltage 2	V_{OL2}	P70 to P77, P80 to P87	$V_{CC} = 4.5\text{ V}$ $I_{OL} = 30.0\text{ mA}$	—	—	0.55	V	
Large current output drive capacity variation 1	ΔV_{OH2}	PWM1Pn, PWM1Mn, PWM2Pn, PWM2Mn, n = 0 to 3	$V_{CC} = 4.5\text{ V}$ $I_{OH} = 30.0\text{ mA}$ V_{OH2} maximum variation	0	—	90	mV	*4
Large current output drive capacity variation 2	ΔV_{OL2}	PWM1Pn, PWM1Mn, PWM2Pn, PWM2Mn, n = 0 to 3	$V_{CC} = 4.5\text{ V}$ $I_{OH} = 30.0\text{ mA}$ V_{OL2} maximum variation	0	—	90	mV	*4
LCD internal divider resistance	R_{LCD}	V0 to V1, V1 to V2, V2 to V3	—	50	100	200	$\text{k}\Omega$	

(Continued)

MB90420G/425G Series

(Continued)

($V_{CC} = 5.0 V \pm 10\%$, $V_{SS} = DV_{SS} = AV_{SS} = 0.0 V$, $T_A = -40\text{ }^\circ\text{C}$ to $+105\text{ }^\circ\text{C}$)

Parameter	Symbol	Pin name	Conditions	Value			Unit	Remarks
				Min	Typ	Max		
COM0 to COM3 output impedance	R_{VCOM}	COMn (n = 0 to 3)	—	—	—	2.5	$k\Omega$	
SEG0 to SEG3 output impedance	R_{VSEG}	SEgn (n = 00 to 23)	—	—	—	15	$k\Omega$	
LCD leakage current	I_{LCDC}	V0 to V3 COMm (m = 0 to 3) SEgn (n = 00 to 23)	—	- 5.0	—	+ 5.0	μA	

*1 : All input pins except X0, X0A, MD0, MD1, MD2 pins.

*2 : MD0, MD1, MD2 pins.

*3 : Supply current values assume external clock feed from the X1 pin and X1A pin. Users must be aware that supply current levels differ depending on whether an external clock or oscillator is used.

*4 : Defined as maximum variation in V_{OH2}/V_{OL2} with all channel 0 PWM1P0/PWM1M0/PWM2P0/PWM2M0 simultaneously ON. Similarly for other channels.

4. AC Characteristics

(1) Clock timing

($V_{CC} = 5.0 V \pm 10\%$, $V_{SS} = DV_{SS} = AV_{SS} = 0.0 V$, $T_A = -40\text{ }^\circ\text{C}$ to $+105\text{ }^\circ\text{C}$)

Parameter	Symbol	Pin name	Condi-tions	Value			Unit	Remarks
				Min	Typ	Max		
Base oscillation clock frequency	F_C	X0, X1	—	—	4	—	MHz	
	F_{LC}	X0A, X1A		—	32.768	—	kHz	
Base oscillation clock cycle time	t_{CYL}	X0, X1		—	250	—	ns	
	t_{LCYL}	X0A, X1A		—	30.5	—	μs	
Input clock pulse width	P_{WH}, P_{WL}	X0		10	—	—	ns	Use duty ratio of 40 to 60% as a guideline
	P_{WLH}, P_{WLL}	X0A		—	15.2	—	μs	
Input clock rise, fall time	t_{cr}, t_{cf}	X0, X0A		—	—	5	ns	With external clock signal
Input operating clock frequency	F_{CP}	—		2	—	16	MHz	Using main clock, PLL clock
	F_{LCP}	—		—	8.192	—	kHz	Using sub clock
Input operating clock cycle time	t_{CP}	—		62.5	—	500	ns	Using main clock, PLL clock
	t_{LCP}	—	—	122.1	—	μs	Using sub clock	

• X0 clock timing

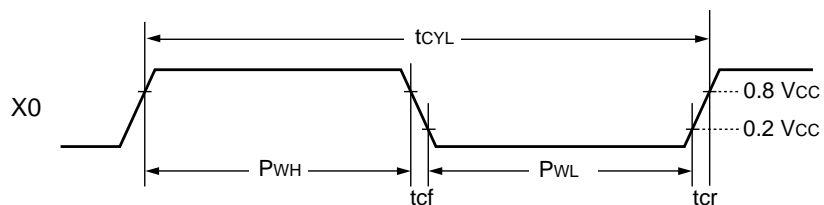

• X0A clock timing

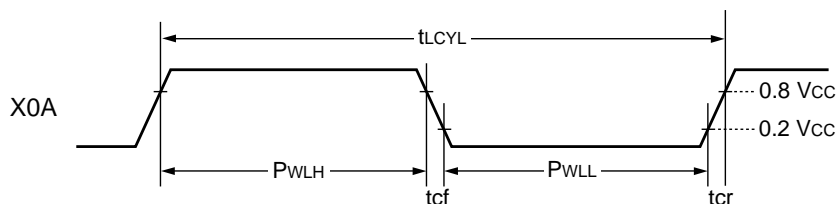

MB90420G/425G Series

- Range of warranted operation

Relation between internal operating clock frequency and supply voltage

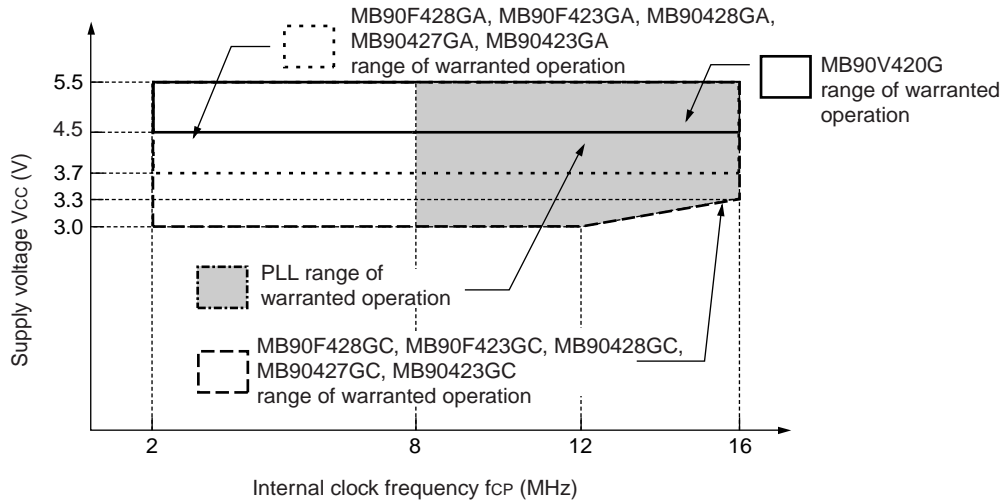

The MB90F428GA, MB90F423GA, MB90428GA, MB90427GA, and MB90423GA enter reset mode at supply voltage below $4\text{ V} \pm 0.3\text{ V}$.

Relation between oscillator clock frequency and internal operating clock frequency

		Internal operating clock frequency				
		Main clock	PLL clock			
			Multiplier $\times 1$	Multiplier $\times 2$	Multiplier $\times 3$	Multiplier $\times 4$
Oscillation clock frequency	4 MHz	2 MHz	—	8 MHz	12 MHz	16 MHz

- Sample oscillator circuit

Oscillator element manufacturer	Oscillator	Frequency	C1	C2
Murata Manufacturing Co., Ltd.	CSTCR4M00G15 () A-R0	4 MHz	39 [pF] (Typ)	39 [pF] (Typ)

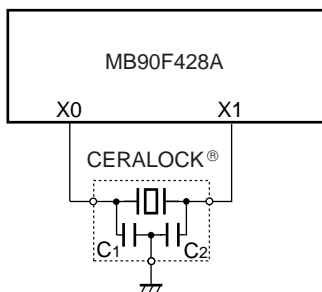

AC ratings are defined for the following measurement reference voltage values:

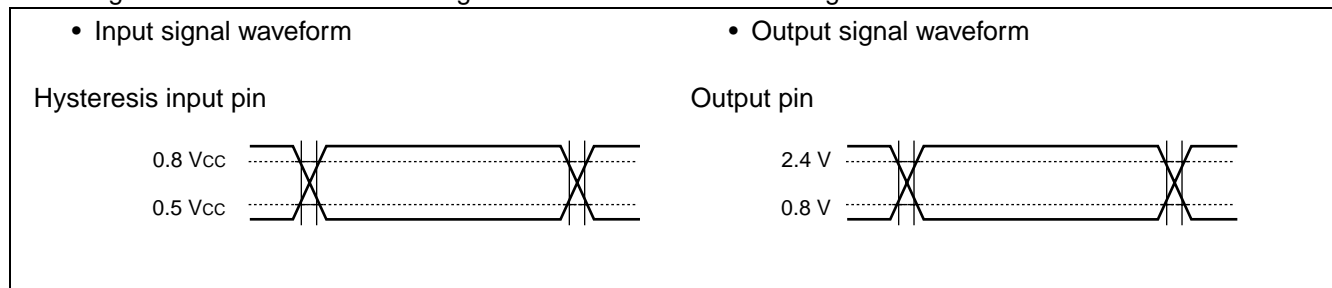

MB90420G/425G Series

(2) Reset input

($V_{CC} = 5.0 V \pm 10\%$, $V_{SS} = AV_{SS} = 0.0 V$, $T_A = -40\text{ }^\circ\text{C}$ to $+105\text{ }^\circ\text{C}$)

Parameter	Symbol	Pin name	Conditions	Value		Unit	Remarks
				Min	Max		
Reset input time	t_{RSTL}	\overline{RST}	—	16 t_{CP}	—	ns	In normal operation
				Oscillator oscillation time* + 16 t_{CP}	—	ms	In stop mode, sub clock mode, sub sleep mode, watch mode

*: Oscillator oscillation time is the time to reach 90% amplitude. For a crystal oscillator, this is a few to several hundred ms; for a FAR/ceramic oscillator, this is several hundred ms to a few ms, and for an external clock this is 100 μs .

Note : t_{CP} : See “ (1) Clock input timing”.

- Under normal operation

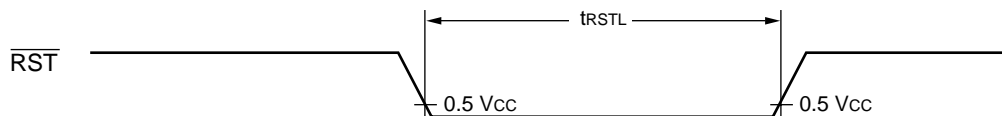

- In stop mode, sub clock mode, sub sleep mode, watch mode

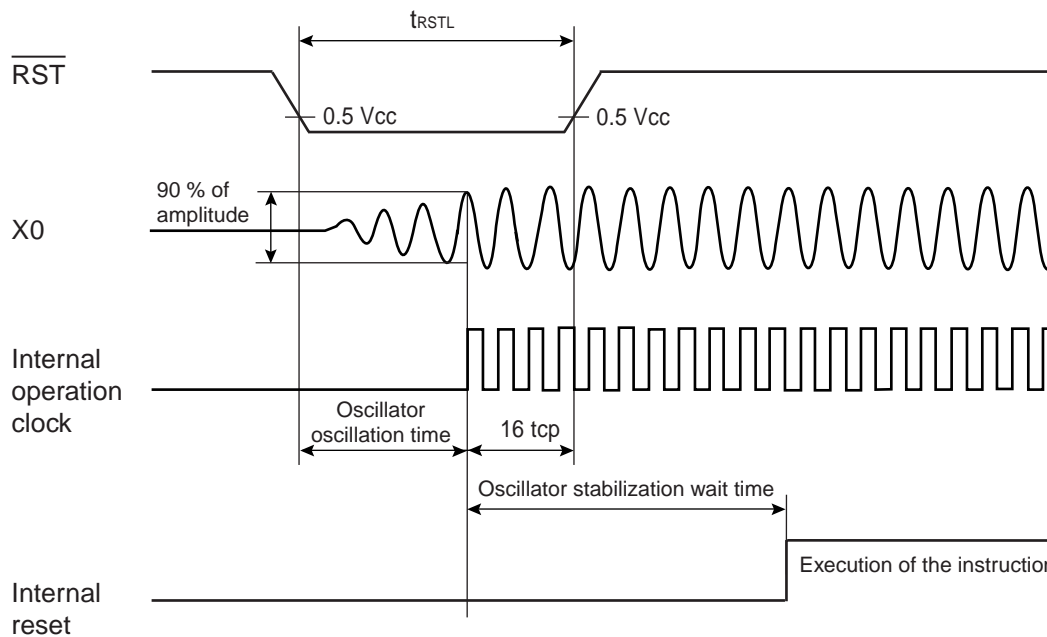

MB90420G/425G Series

(3) Power-on reset, power on conditions

($V_{SS} = 0.0\text{ V}$, $T_A = 40\text{ °C to } +105\text{ °C}$)

Parameter	Symbol	Pin name	Conditions	Value		Unit	Remarks
				Min	Max		
Power supply rise time	t_R	V _{CC}	—	0.05	30	ms	
Power supply start voltage	V_{OFF}			—	0.2	V	
Power supply attained voltage	V_{ON}			2.7	—	V	
Power supply cutoff time	t_{OFF}			50	—	ms	For repeat operation

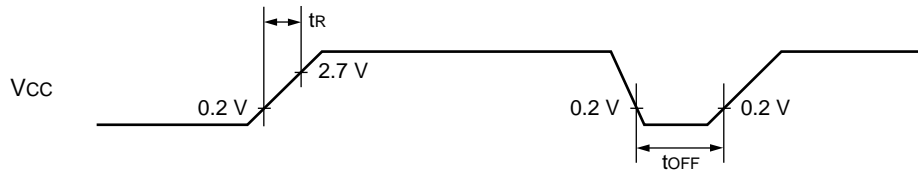

Extreme variations in voltage supply may activate a power-on reset.

As the illustration below shows, when varying supply voltage during operation the use of a smooth voltage rise with suppressed fluctuation is recommended. Also in this situation, the PLL clock on the device should not be used, however it is permissible to use the PLL clock during a voltage drop of 1V/s or less.

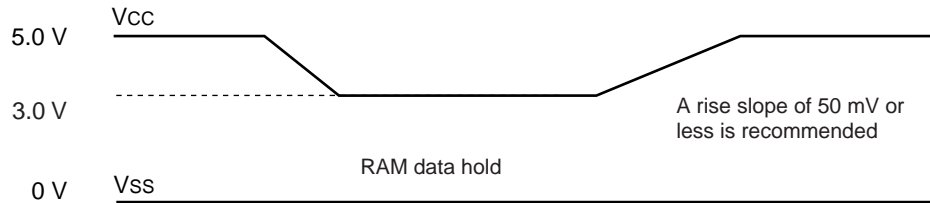

MB90420G/425G Series

(4) UART0, UART1 timing

($V_{CC} = 5.0 V \pm 10\%$, $V_{SS} = AV_{SS} = 0.0 V$, $T_A = -40\text{ }^\circ\text{C}$ to $+105\text{ }^\circ\text{C}$)

Parameter	Symbol	Pin name	Conditions	Value		Unit	Remarks
				Min	Max		
Serial clock cycle time	t_{SCYC}	SCK0, SCK1	—	$8 t_{CP}$	—	ns	Internal shift clock mode output pin $C_L = 80\text{ pF} + 1\bullet\text{TTL}$
SCK fall to SOT delay time	t_{SLOV}	SCK0, SCK1 SOT0, SOT1		- 80	80	ns	
Valid SIN to SCK rise	t_{IVSH}	SCK0, SCK1		100	—	ns	
SCK rise to valid SIN hold time	t_{SHIX}	SIN0, SIN1		60	—	ns	
Serial clock "H" pulse width	t_{SHSL}	SCK0, SCK1	—	$4 t_{CP}$	—	ns	External shift clock mode output pin $C_L = 80\text{ pF} + 1\bullet\text{TTL}$
Serial clock "L" pulse width	t_{SLSH}			$4 t_{CP}$	—	ns	
SCK fall to SOT delay time	t_{SLOV}	SCK0, SCK1 SOT0, SOT1		—	150	ns	
Valid SIN to SCK rise	t_{IVSH}	SCK0, SCK1		60	—	ns	
SCK rise to valid SIN hold time	t_{SHIX}	SIN0, SIN1		60	—	ns	

- Notes :
- AC ratings are for CLK synchronous mode.
 - C_L is load capacitance connected to pin during testing.
 - t_{CP} : See "(1) Clock timing".

• Internal shift clock mode

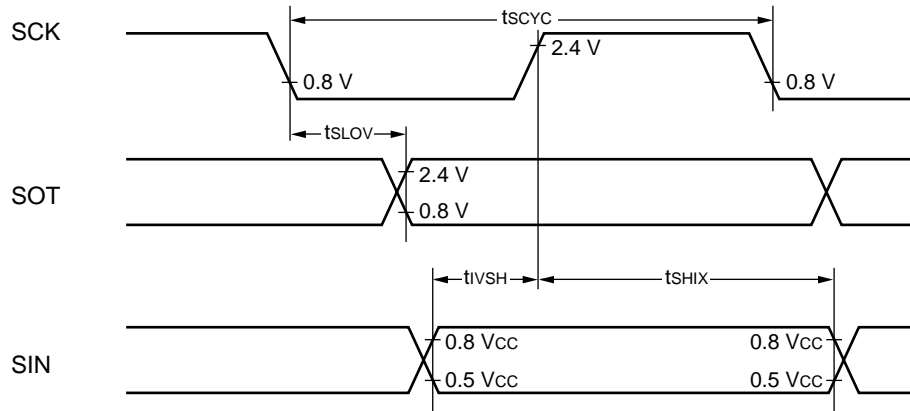

• External shift clock mode

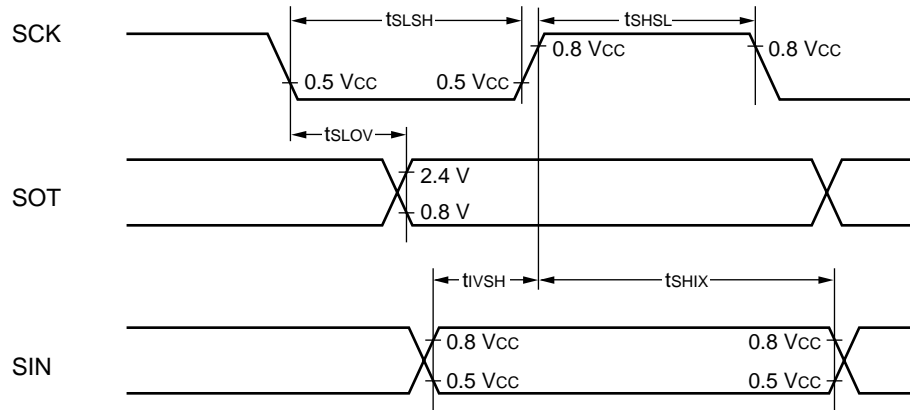

(5) Timer input timing

($V_{CC} = 5.0\text{ V} \pm 10\%$, $V_{SS} = AV_{SS} = 0.0\text{ V}$, $T_A = -40\text{ }^\circ\text{C}$ to $+105\text{ }^\circ\text{C}$)

Parameter	Symbol	Pin name	Conditions	Value		Unit	Remarks
				Min	Max		
Input pulse width	t_{TIWH} t_{TIWL}	TIN0, TIN1, INO, IN1, IN2, IN3,	—	4 t_{CP}	—	ns	

Note : t_{CP} : See “ (1) Clock timing”.

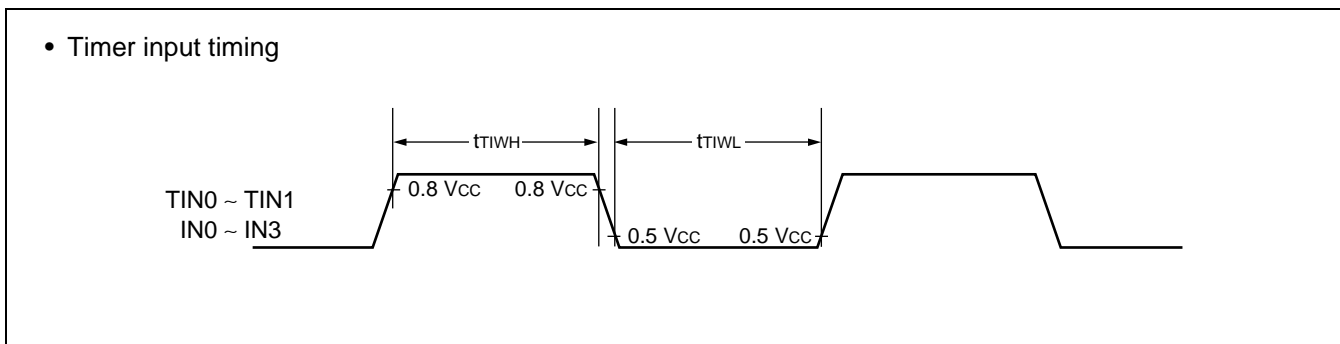

(6) Trigger input timing

($V_{CC} = 5.0\text{ V} \pm 10\%$, $V_{SS} = AV_{SS} = 0.0\text{ V}$, $T_A = -40\text{ }^\circ\text{C}$ to $+105\text{ }^\circ\text{C}$)

Parameter	Symbol	Pin name	Conditions	Value		Unit	Remarks
				Min	Max		
Input pulse width	t_{TRGH} , t_{TRGL}	INT0 to INT7	—	5 t_{CP}	—	ns	Under normal operation
				1	—	μs	In stop mode

Note : t_{CP} : See “ (1) Clock timing”.

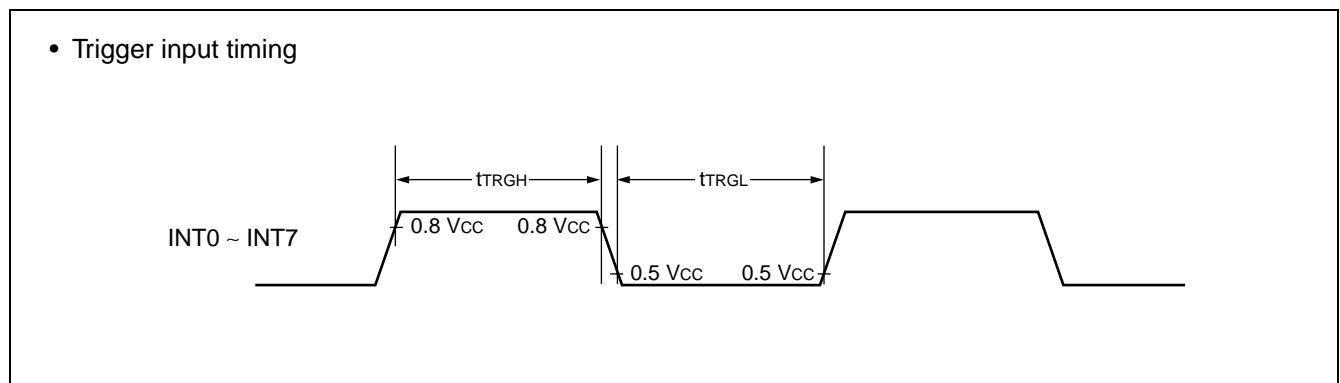

MB90420G/425G Series

(7) Low voltage detection

($V_{SS} = AV_{SS} = 0.0\text{ V}$, $T_A = -40\text{ }^\circ\text{C}$ to $+105\text{ }^\circ\text{C}$)

Parameter	Symbol	Pin name	Conditions	Value			Unit	Remarks
				Min	Typ	Max		
Detection voltage	V_{DL}	V_{CC}	—	3.7	4.0	4.3	V	During voltage drop
Hysteresis width	V_{HYS}	V_{CC}	—	0.1	—	—	V	During voltage rise
Power supply voltage fluctuation ratio	dV/dt	V_{CC}	—	- 0.1	—	0.02	V/ μs	
Detection delay time	t_d	—	—	—	—	35	μs	

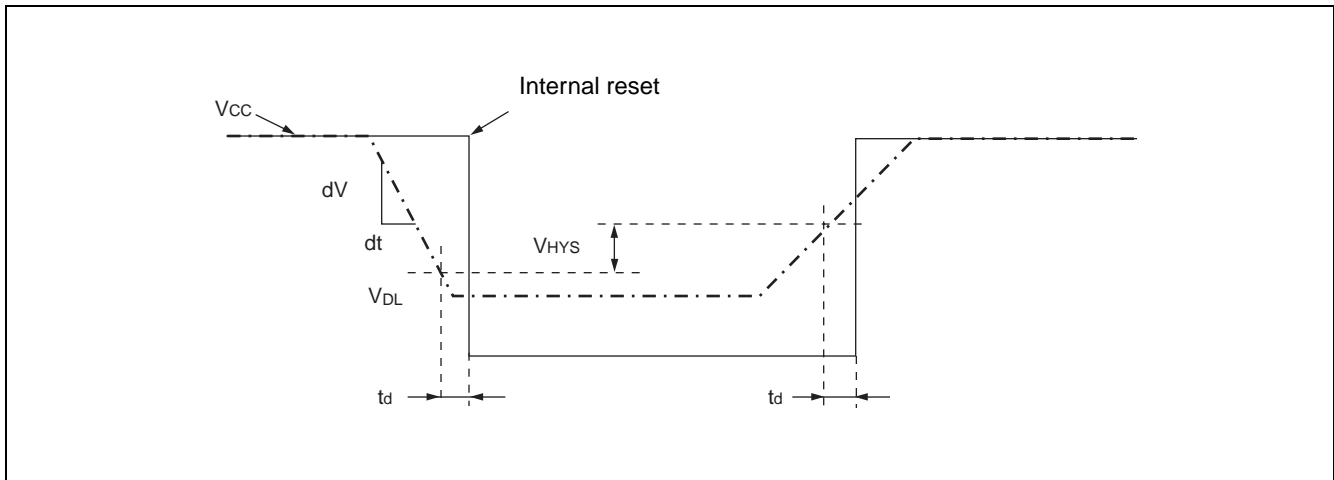

5. A/D Conversion Block

(1) Electrical Characteristics

($V_{CC} = AV_{CC} = 5.0 \text{ V} \pm 10\%$, $V_{SS} = AV_{SS} = 0.0 \text{ V}$, $T_A = -40 \text{ }^\circ\text{C}$ to $+105 \text{ }^\circ\text{C}$)

Parameter	Symbol	Pin name	Value			Unit	Remarks
			Min	Typ	Max		
Resolution	—	—	—	—	10	bit	
Total error	—	—	—	—	± 5.0	LSB	
Non-linear error	—	—	—	—	± 2.5	LSB	
Differential linear error	—	—	—	—	± 1.9	LSB	
Zero transition voltage	V_{OT}	AN0 to AN7	$AV_{SS} - 3.5 \text{ LSB}$	$AV_{SS} + 0.5 \text{ LSB}$	$AV_{SS} + 4.5 \text{ LSB}$	V	1 LSB = ($AV_{RH} - AV_{SS}$) / 1024
Full scale transition voltage	V_{FST}	AN0 to AN7	$AV_{RH} - 6.5 \text{ LSB}$	$AV_{RH} - 1.5 \text{ LSB}$	$AV_{RH} + 1.5 \text{ LSB}$	V	
Sampling time	t_{SMP}	—	2.000	—	—	μs	*1
Compare time	t_{CMP}	—	4.125	—	—	μs	*2
A/D conversion time	t_{CNV}	—	6.125	—	—	μs	*3
Analog port input current	I_{AIN}	AN0 to AN7	—	—	10	μA	$V_{AVSS} = V_{AIN} = V_{AVCC}$
Analog input current	V_{AIN}	AN0 to AN7	0	—	AV_{RH}	V	
Reference voltage	$AVR+$	AV_{RH}	3.0	—	AV_{CC}	V	
Power supply current	I_A	AV_{CC}	—	2.3	6.0	mA	
	I_{AH}		—	—	5	μA	*4
Reference voltage feed current	I_R	AV_{RH}	50	180	260	μA	$V_{AVRH} = 5.0 \text{ V}$
	I_{RH}	AV_{RH}	—	—	5	μA	*4
Inter-channel variation	—	AN0 to AN7	—	—	4	LSB	

*1 : At $F_{CP} = 16 \text{ MHz}$, $t_{SMP} = 32 \times t_{CP} = 2.000 \text{ }(\mu\text{s})$.

*2 : At $F_{CP} = 16 \text{ MHz}$, $t_{CMP} = 66 \times t_{CP} = 4.125 \text{ }(\mu\text{s})$.

*3 : Equivalent to conversion time per channel at $F_{CP} = 16 \text{ MHz}$, and selection of $t_{SMP} = 32 \times t_{CP}$ and $t_{CMP} = 66 \times t_{CP}$.

*4 : Defined as supply current (when $V_{CC} = AV_{CC} = AV_{RH} = 5.0 \text{ V}$) with A/D converter not operating, and CPU in stop mode.

MB90420G/425G Series

- **Notes of the external impedance of the analog input and its sampling time**

- A/D converter with sample and hold circuit. If the external impedance is too high to keep sufficient sampling time, the analog voltage charged to the internal sample and hold capacitor is insufficient, adversely affecting A/D conversion precision.

- Analog input circuit model

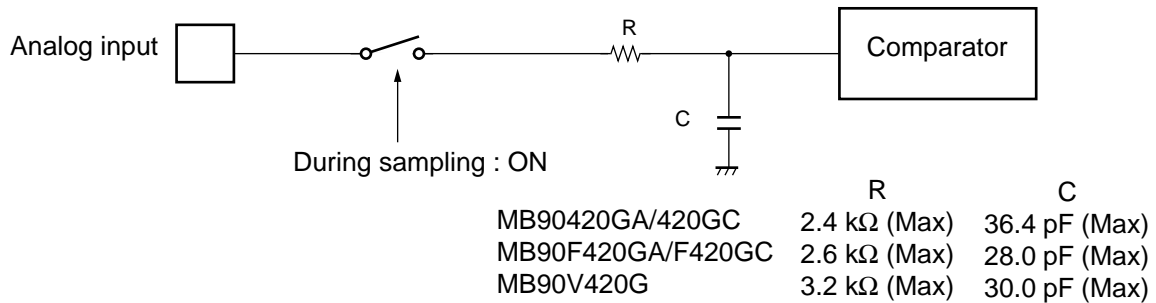

Note : The values are reference values.

- To satisfy the A/D conversion precision standard, consider the relationship between the external impedance and minimum sampling time and either adjust the resistor value and operating frequency or decrease the external impedance so that the sampling time is longer than the minimum value.

- The relationship between the external impedance and minimum sampling time

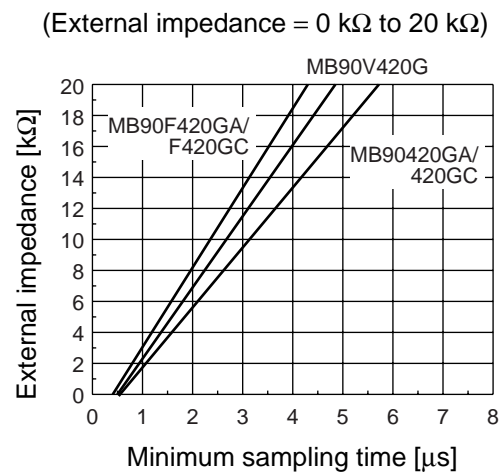
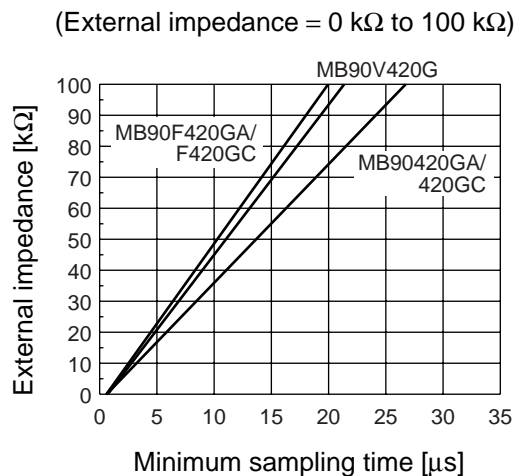

- If the sampling time cannot be sufficient, connect a capacitor of about 0.1 μF to the analog input pin.
- About errors
As $|AVRH|$ becomes smaller, values of relative errors grow larger.

(2) Definition of terms

- Resolution
Indicates the ability of the A/D converter to discriminate in analog conversion.
10-bit resolution indicates that analog voltage can be resolved into $2^{10} = 1024$ levels.
- Total error
Expresses the difference between actual and logical values. It is the total value of errors that can come from offset error, gain error, non-linearity error and noise.
- Linearity error
Expresses the deviation between actual conversion characteristics and a straight line connecting the device's zero transition point (00 0000 0000 \longleftrightarrow 00 0000 0001) and full scale transition point (11 1111 1110 \longleftrightarrow 11 1111 1111).
- Differential linearity error
Expresses the deviation of the logical value of input voltage required to create a variation of 1 LSB in output code.

• 10-bit A/D converter conversion characteristics

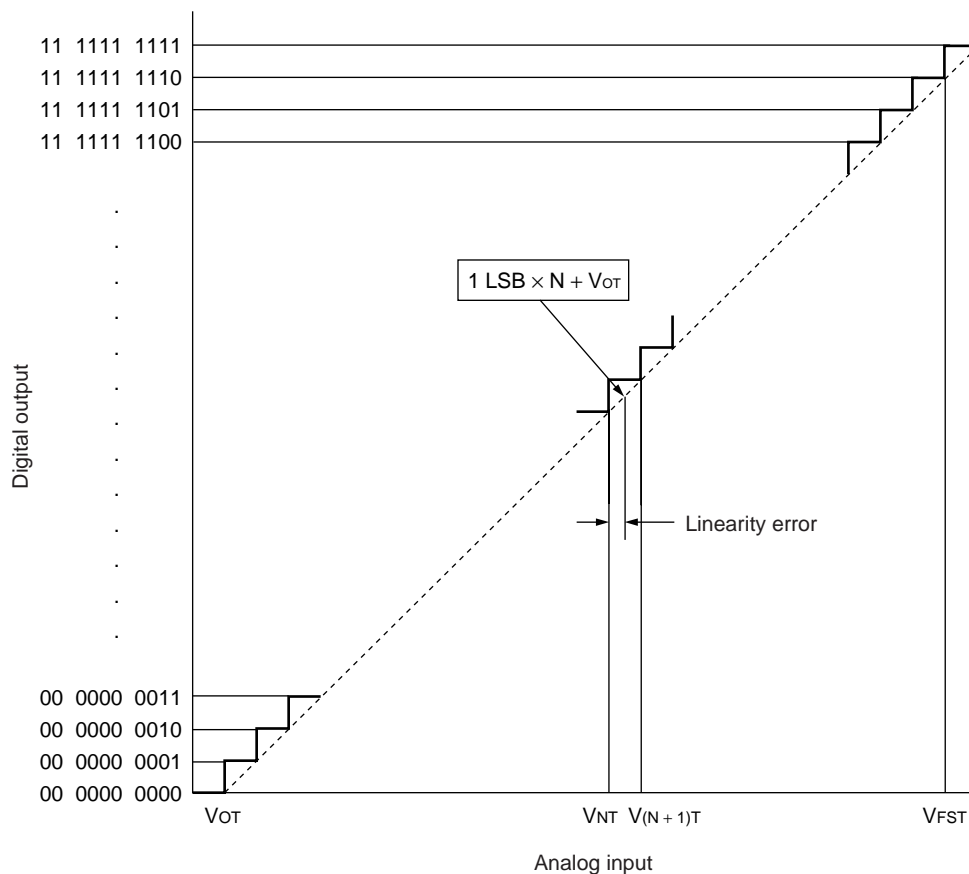

$$1 \text{ LSB} = \frac{V_{FST} - V_{OT}}{1022}$$

$$\text{Linearity error} = \frac{V_{NT} - (1 \text{ LSB} \times N + V_{OT})}{1 \text{ LSB}} \text{ [LSB]}$$

$$\text{Differential linearity error} = \frac{V_{(N+1)T} - V_{NT}}{1 \text{ LSB}} - 1 \text{ [LSB]}$$

MB90420G/425G Series

6. Flash Memory Program and Erase Performances

Parameter	Conditions	Value			Unit	Remarks
		Min	Typ	Max		
Sector erase time	T _A = + 25 °C V _{CC} = 5.0 V	—	1	15	s	Excludes 00 _H programming prior erasure
Chip erase time		—	5	—	s	Excludes 00 _H programming prior erasure
Word (16 bit width) programming time		—	16	3,600	μs	Excludes system-level overhead
Erase/Program cycle	—	10,000	—	—	cycle	
Flash data retention time	Average T _A = + 85 °C	10	—	—	year	*

* : This value comes from the technology qualification. (using Arrhenius equation to translate high temperature measurements into normalized value at + 85 °C)

EXAMPLE CHARACTERISTICS

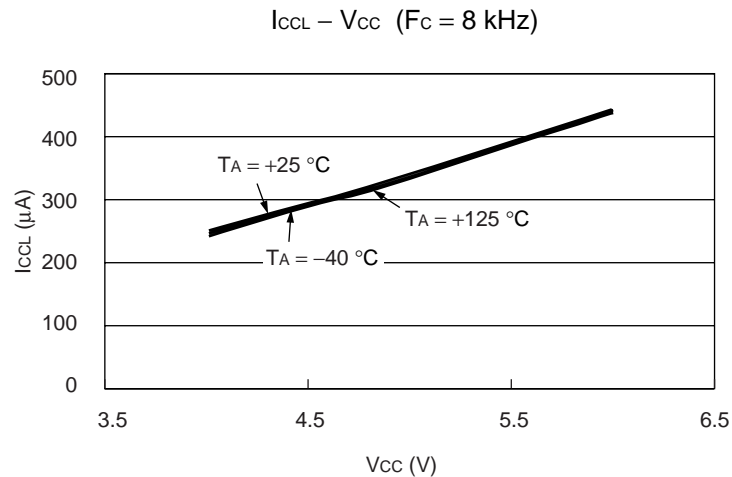
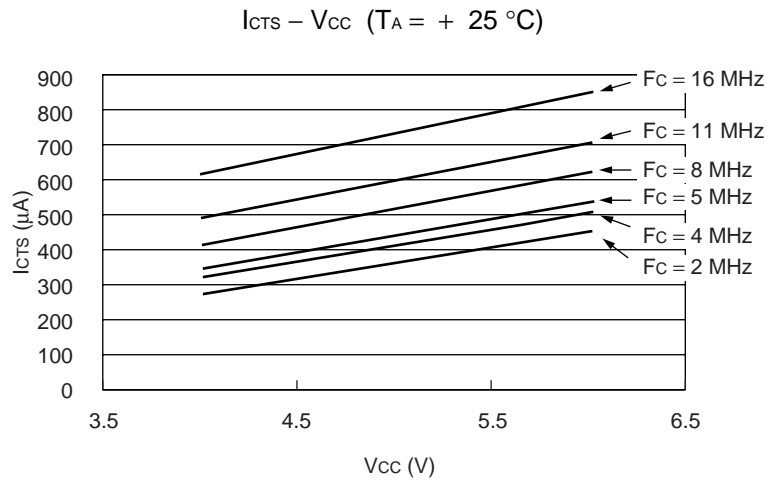
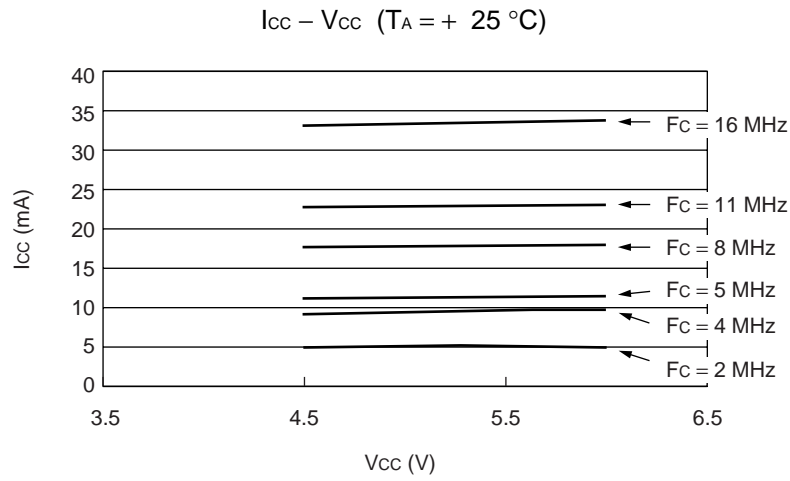

(Continued)

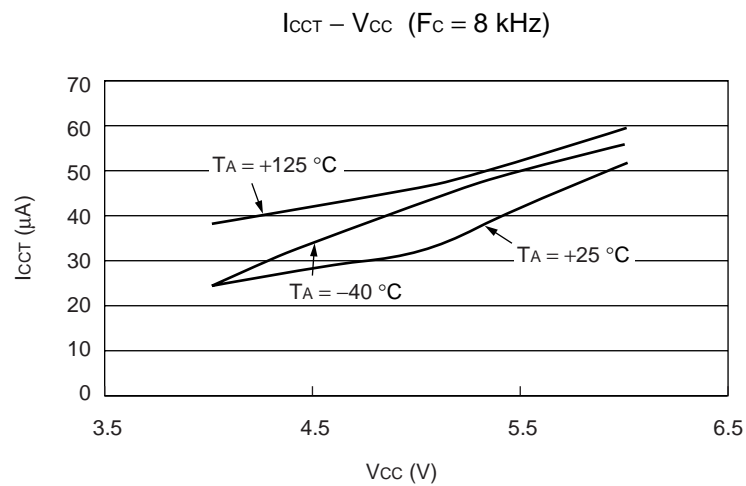
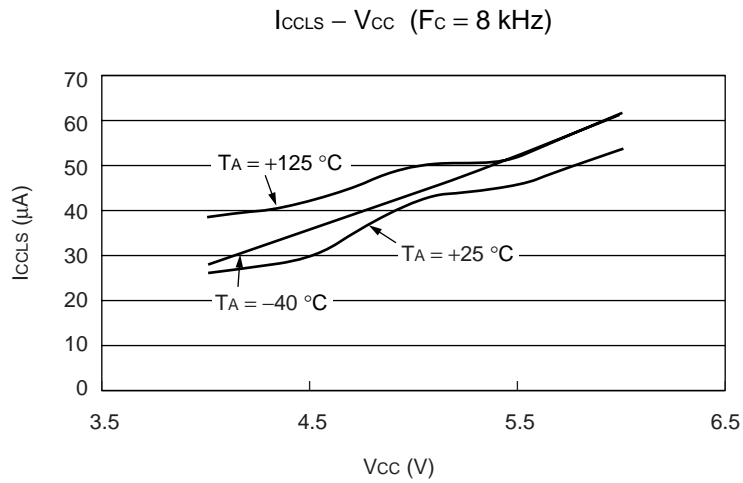

MB90420G/425G Series

■ ORDERING INFORMATION

Part number	Package	Remarks
MB90F423GAPF MB90F423GCPF MB90F428GAPF MB90F428GCPF MB90423GAPF MB90423GCPF MB90427GAPF MB90427GCPF MB90428GAPF MB90428GCPF	Plastic QFP, 100-pin (FPT-100P-M06)	
MB90F423GAPMC MB90F423GCPMC MB90F428GAPMC MB90F428GCPMC MB90423GAPMC MB90423GCPMC MB90427GAPMC MB90427GCPMC MB90428GAPMC MB90428GCPMC	Plastic LQFP, 100-pin (FPT-100P-M20)	

MB90420G/425G Series

PACKAGE DIMENSIONS

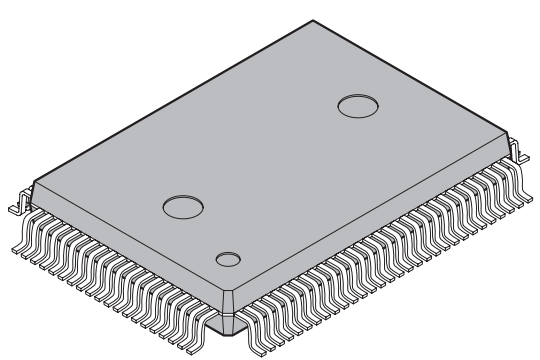
 <p>100-pin plastic QFP</p> <p>(FPT-100P-M06)</p>	Lead pitch	0.65 mm
	Package width × package length	14.00 × 20.00 mm
	Lead shape	Gullwing
	Sealing method	Plastic mold
	Mounting height	3.35 mm MAX
	Code (Reference)	P-QFP100-14×20-0.65

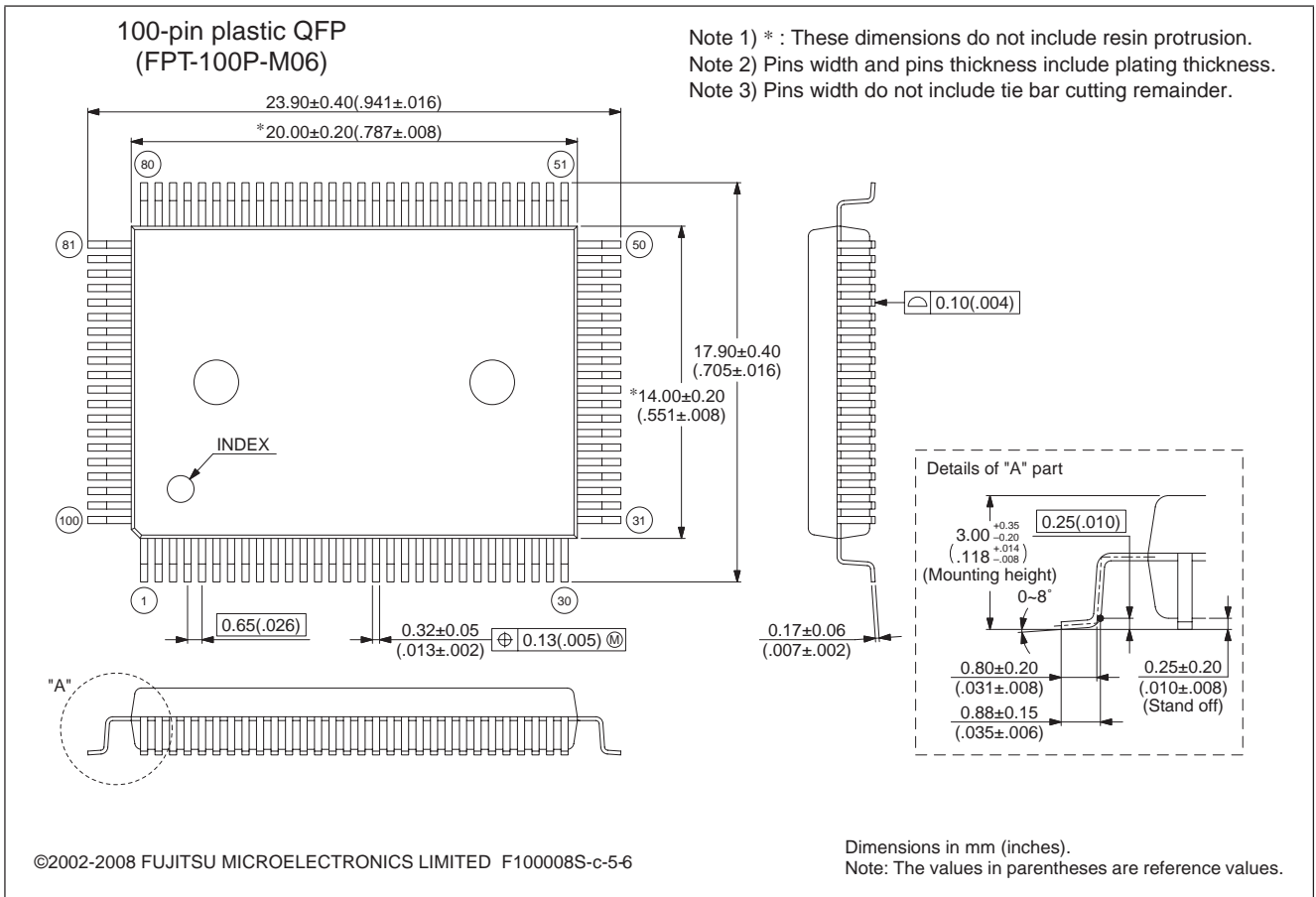

Please confirm the latest Package dimension by following URL.
<http://edevic.fujitsu.com/package/en-search/>

(Continued)

MB90420G/425G Series

(Continued)

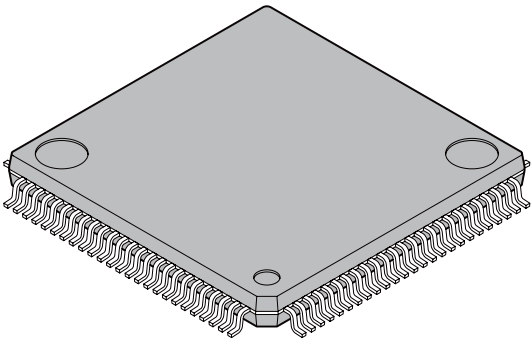
<p>100-pin plastic LQFP</p>  <p>(FPT-100P-M20)</p>	Lead pitch	0.50 mm
	Package width × package length	14.0 mm × 14.0 mm
	Lead shape	Gullwing
	Sealing method	Plastic mold
	Mounting height	1.70 mm Max
	Weight	0.65 g
	Code (Reference)	P-LFQFP100-14×14-0.50

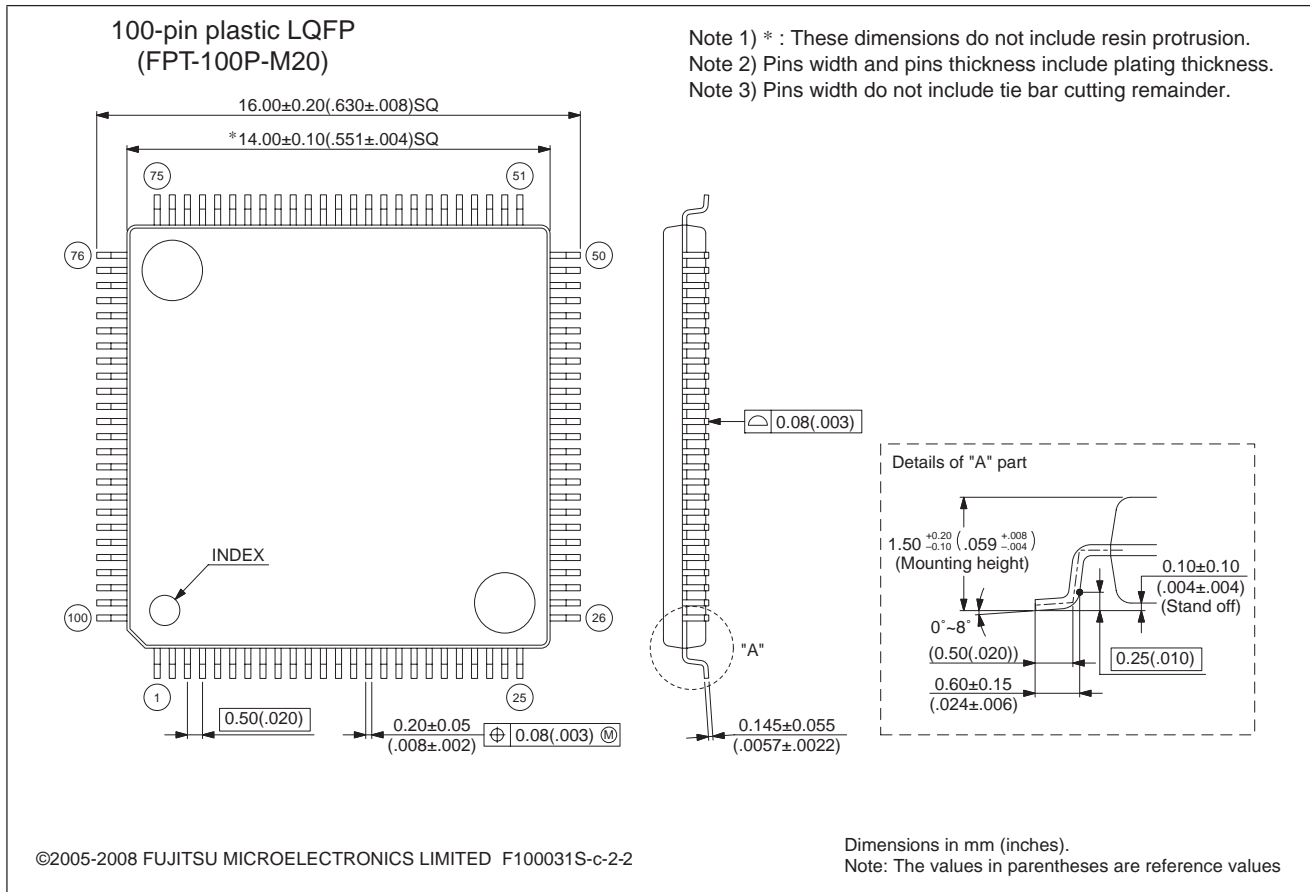

Please confirm the latest Package dimension by following URL.
<http://edevic.fujitsu.com/package/en-search/>

MB90420G/425G Series

■ MAIN CHANGES IN THIS EDITION

Page	Section	Change Results
-	-	The package code is changed. (FPT-100P-M05 → FPT-100P-M20)
5	■ PIN ASSIGNMENTS	Figure of QFP package pin assignment is changed.
81	■ ORDERING INFORMATION	Order informations are changed. (MB90423GAPFV → MB90423GAPMC, MB90423GCPFV → MB90423GCPMC, MB90427GAPFV → MB90427GAPMC, MB90427GCPFV → MB90427GCPMC, MB90428GAPFV → MB90428GAPMC, MB90428GCPFV → MB90428GCPMC, MB90F423GAPFV → MB90F423GAPMC, MB90F423GCPFV → MB90F423GCPMC, MB90F428GAPFV → MB90F428GAPMC, MB90F428GCPFV → MB90F428GCPMC)
83	■ PACKAGE DIMENSIONS	The package figure is changed. (FPT-100P-M05 → FPT-100P-M20)

The vertical lines marked in the left side of the page show the changes.

MEMO

MEMO

MEMO

MB90420G/425G Series

FUJITSU MICROELECTRONICS LIMITED

Shinjuku Dai-Ichi Seimei Bldg. 7-1, Nishishinjuku 2-chome, Shinjuku-ku,
Tokyo 163-0722, Japan Tel: +81-3-5322-3347 Fax: +81-3-5322-3387
<http://jp.fujitsu.com/fml/en/>

For further information please contact:

North and South America

FUJITSU MICROELECTRONICS AMERICA, INC.
1250 E. Arques Avenue, M/S 333
Sunnyvale, CA 94085-5401, U.S.A.
Tel: +1-408-737-5600 Fax: +1-408-737-5999
<http://www.fma.fujitsu.com/>

Europe

FUJITSU MICROELECTRONICS EUROPE GmbH
Pittlerstrasse 47, 63225 Langen,
Germany
Tel: +49-6103-690-0 Fax: +49-6103-690-122
<http://emea.fujitsu.com/microelectronics/>

Korea

FUJITSU MICROELECTRONICS KOREA LTD.
206 KOSMO TOWER, 1002 Daechi-Dong,
Kangnam-Gu, Seoul 135-280
Korea
Tel: +82-2-3484-7100 Fax: +82-2-3484-7111
<http://www.fmk.fujitsu.com/>

Asia Pacific

FUJITSU MICROELECTRONICS ASIA PTE LTD.
151 Lorong Chuan, #05-08 New Tech Park,
Singapore 556741
Tel: +65-6281-0770 Fax: +65-6281-0220
<http://www.fujitsu.com/sg/services/micro/semiconductor/>

FUJITSU MICROELECTRONICS SHANGHAI CO., LTD.
Rm.3102, Bund Center, No.222 Yan An Road(E),
Shanghai 200002, China
Tel: +86-21-6335-1560 Fax: +86-21-6335-1605
<http://cn.fujitsu.com/fmc/>

FUJITSU MICROELECTRONICS PACIFIC ASIA LTD.
10/F., World Commerce Centre, 11 Canton Road
Tsimshatsui, Kowloon
Hong Kong
Tel: +852-2377-0226 Fax: +852-2376-3269
<http://cn.fujitsu.com/fmc/tw>

All Rights Reserved.

The contents of this document are subject to change without notice.

Customers are advised to consult with sales representatives before ordering.

The information, such as descriptions of function and application circuit examples, in this document are presented solely for the purpose of reference to show examples of operations and uses of FUJITSU MICROELECTRONICS device; FUJITSU MICROELECTRONICS does not warrant proper operation of the device with respect to use based on such information. When you develop equipment incorporating the device based on such information, you must assume any responsibility arising out of such use of the information.

FUJITSU MICROELECTRONICS assumes no liability for any damages whatsoever arising out of the use of the information.

Any information in this document, including descriptions of function and schematic diagrams, shall not be construed as license of the use or exercise of any intellectual property right, such as patent right or copyright, or any other right of FUJITSU MICROELECTRONICS or any third party or does FUJITSU MICROELECTRONICS warrant non-infringement of any third-party's intellectual property right or other right by using such information. FUJITSU MICROELECTRONICS assumes no liability for any infringement of the intellectual property rights or other rights of third parties which would result from the use of information contained herein.

The products described in this document are designed, developed and manufactured as contemplated for general use, including without limitation, ordinary industrial use, general office use, personal use, and household use, but are not designed, developed and manufactured as contemplated (1) for use accompanying fatal risks or dangers that, unless extremely high safety is secured, could have a serious effect to the public, and could lead directly to death, personal injury, severe physical damage or other loss (i.e., nuclear reaction control in nuclear facility, aircraft flight control, air traffic control, mass transport control, medical life support system, missile launch control in weapon system), or (2) for use requiring extremely high reliability (i.e., submersible repeater and artificial satellite).

Please note that FUJITSU MICROELECTRONICS will not be liable against you and/or any third party for any claims or damages arising in connection with above-mentioned uses of the products.

Any semiconductor devices have an inherent chance of failure. You must protect against injury, damage or loss from such failures by incorporating safety design measures into your facility and equipment such as redundancy, fire protection, and prevention of over-current levels and other abnormal operating conditions.

Exportation/release of any products described in this document may require necessary procedures in accordance with the regulations of the Foreign Exchange and Foreign Trade Control Law of Japan and/or US export control laws.

The company names and brand names herein are the trademarks or registered trademarks of their respective owners.