

16-bit Proprietary Microcontroller

CMOS

F²MC-16LX MB90590G Series

MB90591G/F591G/594G/F594G/V590G

■ DESCRIPTION

The MB90590G series with two FULL-CAN interfaces and FLASH ROM is especially designed for automotive and industrial applications. Its main features are two on board CAN Interfaces, which conform to V2.0 Part A and Part B, while supporting a very flexible message buffer scheme and so offering more functions than a normal full CAN approach.

The instruction set of F²MC-16LX CPU core inherits an AT architecture of the F²MC* family with additional instruction sets for high-level languages, extended addressing mode, enhanced multiplication/division instructions, and enhanced bit manipulation instructions. The microcontroller has a 32-bit accumulator for processing long word data.

The MB90590/590G series has peripheral resources of 8/10-bit A/D converters, UART (SCI), extended I/O serial interface, 8/16-bit PPG timer, I/O timer (input capture (ICU), output compare (OCU)), stepping motor controller, and sound generator.

* : F²MC is the abbreviation of Fujitsu Flexible Microcontroller.

For the information for microcontroller supports, see the following web site.

<http://edevice.fujitsu.com/micom/en-support/>

■ FEATURES

- Clock
 - Embedded PLL clock multiplication circuit
 - Operating clock (PLL clock) can be selected from divided-by-2 of oscillation or one to four times the oscillation (at oscillation of 4 MHz, 4 MHz to 16 MHz).
 - Minimum instruction execution time : 62.5 ns (operation at oscillation of 4 MHz, four times the oscillation clock, V_{CC} of 5.0 V)
- Instruction set to optimize controller applications
 - Rich data types (bit, byte, word, long word)
 - Rich addressing mode (23 types)
 - Enhanced signed multiplication/division instruction and RETI instruction functions
 - Enhanced precision calculation realized by the 32-bit accumulator
- Instruction set designed for high level language (C language) and multi-task operations
 - Adoption of system stack pointer
 - Enhanced pointer indirect instructions
 - Barrel shift instructions
- Program patch function (for two address pointers)
- Enhanced execution speed : 4-byte instruction queue
- Enhanced interrupt function : 8 levels, 34 factors
- Automatic data transmission function independent of CPU operation
 - Extended intelligent I/O service function (EI²OS) : Up to 10 channels
- Embedded ROM size and types
 - Mask ROM : 256 Kbytes/384 Kbytes
 - Flash ROM : 256 Kbytes/384 Kbytes
 - Embedded RAM size : 6 Kbytes/8 Kbytes
- Flash ROM
 - Supports automatic programming, Embedded Algorithm
 - Write/Erase/Erase-Suspend/Resume commands
 - A flag indicating completion of the algorithm
 - Hard-wired reset vector available in order to point to a fixed boot sector in Flash Memory
 - Erase can be performed on each block
 - Block protection with external programming voltage
- Low-power consumption (stand-by) mode
 - Sleep mode (mode in which CPU operating clock is stopped)
 - Stop mode (mode in which oscillation is stopped)
 - CPU intermittent operation mode
 - Watch mode
 - Hardware stand-by mode
- Process
 - 0.5 μ m CMOS technology
- I/O port
 - General-purpose I/O ports : 78 ports
- Timer
 - Watchdog timer : 1 channel
 - 8/16-bit PPG timer : 8/16-bit \times 6 channels
 - 16-bit re-load timer : 2 channels

- 16-bit I/O timer
 - 16-bit free-run timer : 1 channel
 - Input capture : 6 channels
 - Output compare : 6 channels
- Extended I/O serial interface : 1 channel
- UART (3 channels)
 - With full-duplex double buffer (8-bit length)
 - Clock asynchronous or clock synchronized (with start/stop bit) transmission can be selectively used.
- Stepping motor controller (4 channels)
- External interrupt circuit (8 channels)
 - A module for starting an extended intelligent I/O service (EI²OS) and generating an external interrupt which is triggered by an external input.
- Delayed interrupt generation module
 - Generates an interrupt request for switching tasks.
- 8/10-bit A/D converter (8 channels)
 - 8/10-bit resolution can be selectively used.
 - Starting by an external trigger input.
- FULL-CAN interfaces : 2
 - Conforming to Version 2.0 Part A and Part B
 - Flexible message buffering (mailbox and FIFO buffering can be mixed)
- Sound generator
- 18-bit Time-base counter
- Watch timer : 1 channel
- External bus interface : Maximum address space 16 Mbytes

MB90590G Series

■ PRODUCT LINEUP

Features		MB90591G/594G	MB90F591G/F594G	MB90V590G
Classification		Mask ROM product	Flash ROM product	Evaluation product
ROM size		384/256 Kbytes	384/256 Kbytes Boot block Hard-wired reset vector	None
RAM size		8/6 Kbytes	8/6 Kbytes	8 Kbytes
Emulator-specific power supply *1		—		None
CPU functions		The number of instructions : 340 Instruction bit length : 8 bits, 16 bits Instruction length : 1 byte to 7 bytes Data bit length : 1 bit, 8 bits, 16 bits Minimum execution time : 62.5 ns (at machine clock frequency of 16 MHz) Interrupt processing time : 1.5 μ s (at machine clock frequency of 16 MHz, minimum value)		
UART (3 channels)		Clock synchronized transmission (500 Kbps / 1 Mbps / 2 Mbps) Clock asynchronized transmission (4808/5208/9615/10417/19230/38460/62500 /500000 bps at machine clock frequency of 16 MHz) Transmission can be performed by bi-directional serial transmission or by master/slave connection.		
8/10-bit A/D converter		Conversion precision : 8/10-bit can be selectively used. Number of inputs : 8 One-shot conversion mode (converts selected channel once only) Scan conversion mode (converts two or more successive channels and can program up to 8 channels) Continuous conversion mode (converts selected channel continuously) Stop conversion mode (converts selected channel and stop operation repeatedly)		
8/16-bit PPG timers (6 channels)		Number of channels : 6 (8/16-bit \times 6 channels) PPG operation of 8-bit or 16-bit A pulse wave of given intervals and given duty ratios can be output. Pulse interval : f_{sys} , $f_{sys}/2^1$, $f_{sys}/2^2$, $f_{sys}/2^3$, $f_{sys}/2^4$, 128 μ s (at oscillation of 4 MHz, f_{sys} = system clock frequency of 16 MHz, f_{osc} = oscillation clock frequency)		
16-bit Reload timer		Number of channels : 2 Operation clock frequency : $f_{sys}/2^1$, $f_{sys}/2^3$, $f_{sys}/2^5$ (f_{sys} = System clock frequency) Supports External Event Count function		
16-bit I/O timer	16-bit Output compares	Number of channels : 6 (8/16-bit \times 6 channels) Pin input factor : A match signal of compare register		
	Input captures	Number of channels : 6 Rewriting a register value upon a pin input (rising, falling, or both edges)		

(Continued)

MB90590G Series

(Continued)

Features	MB90591G/594G	MB90F591G/F594G	MB90V590G
CAN Interface	Number of channels : 2 Conforms to CAN Specification Version 2.0 Part A and B Automatic re-transmission in case of error Automatic transmission responding to Remote Frame Prioritized 16 message buffers for data and ID's Supports multiple messages Flexible configuration of acceptance filtering : Full bit compare / Full bit mask / Two partial bit masks Supports up to 1Mbps CAN bit timing setting : MB90(F)59xG : TSEG2 ≥ RSJW		
Stepping motor controller (4 channels)	Four high current outputs for each channel Synchronized two 8-bit PWM's for each channel		
External interrupt circuit	Number of inputs : 8 Started by a rising edge, a falling edge, an "H" level input, or an "L" level input.		
Sound generator	8-bit PWM signal is mixed with tone frequency from 8-bit reload counter PWM frequency : 62.5K, 31.2K, 15.6K, 7.8KHz (at System clock = 16MHz) Tone frequency : PWM frequency / 2 / (reload value + 1)		
Extended I/O serial interface	Clock synchronized transmission (31.25K/62.5K/125K/500K/1Mbps at machine clock frequency of 16 MHz) LSB first/MSB first		
Watch timer	Directly operates with the system clock Read/Write accessible Second/Minute/Hour registers		
Watchdog timer	Reset generation interval : 3.58 ms, 14.33 ms, 57.23 ms, 458.75 ms (at oscillation of 4 MHz, minimum value)		
Flash Memory	Supports automatic programming, Embedded Algorithm and Write/Erase/Erase-Suspend/Resume commands A flag indicating completion of the algorithm Hard-wired reset vector available in order to point to a fixed boot sector in Flash Memory Boot block configuration Erase can be performed on each block Block protection with external programming voltage Flash Writer from Minato Electronics Inc.		
Low-power consumption (stand-by) mode	Sleep/stop/CPU intermittent operation/watch timer/hardware stand-by		
Process	CMOS		
Power supply voltage for operation*2	5 V±10 % (MB90V590G, MB90F594G, MB90594G) 5 V±5 % (MB90F591G, MB90591G)		
Package	QFP-100		PGA-256

*1 : It is setting of DIP switch S2 when Emulation pod (MB2145-507) is used.

Please refer to the MB2145-507 hardware manual (2.7 Emulator-specific Power Pin) about details.

*2 : Varies with conditions such as the operating frequency. (See section "■ Electrical Characteristics.")

MB90590G Series

■ PIN ASSIGNMENT

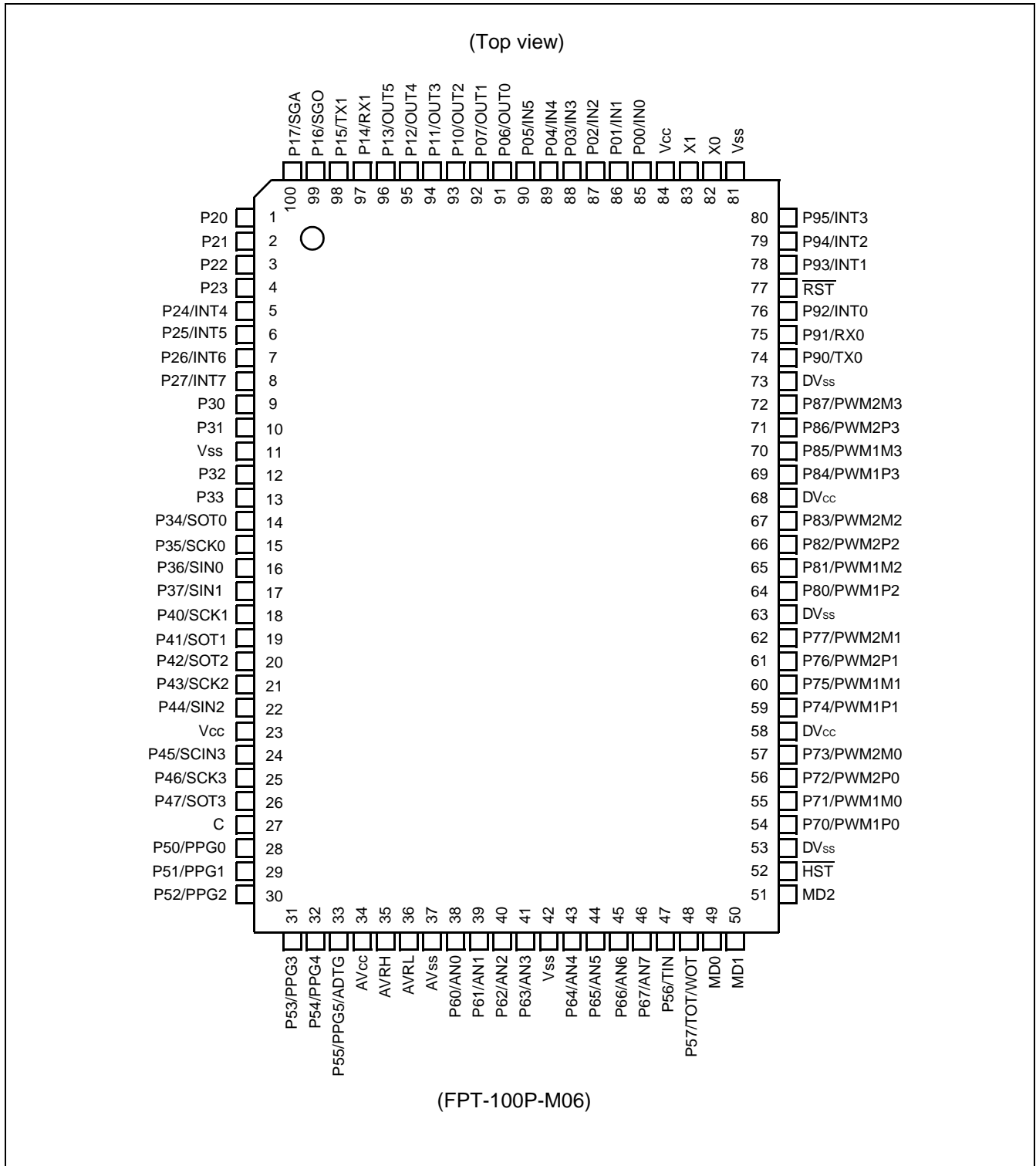

■ PIN DESCRIPTION

No.	Pin name	Circuit type	Function
82	X0	A	Oscillator pin
83	X1		
77	$\overline{\text{RST}}$	B	Reset input
52	$\overline{\text{HST}}$	C	Hardware standby input
85 to 90	P00 to P05	D	General purpose I/O
	IN0 to IN5		Inputs for the Input Captures
91 to 96	P06, P07, P10 to P13	D	General purpose I/O
	OUT0 to OUT5		Outputs for the Output Compares. To enable the signal outputs, the corresponding bits of the Port Direction registers should be set to "1".
97	P14	D	General purpose I/O
	RX1		RX input for CAN Interface 1
98	P15	D	General purpose I/O
	TX1		TX output for CAN Interface 1. To enable the signal output, the corresponding bit of the Port Direction register should be set to "1".
99	P16	D	General purpose I/O
	SGO		SGO output for the Sound Generator. To enable the signal output, the corresponding bit of the Port Direction register should be set to "1".
100	P17	D	General purpose I/O
	SGA		SGA output for the Sound Generator. To enable the signal output, the corresponding bit of the Port Direction register should be set to "1".
1 to 4	P20 to P23	D	General purpose I/O
5 to 8	P24 to P27	D	General purpose I/O
	INT4 to INT7		External interrupt input for INT4 to INT7
9, 10	P30, P31	D	General purpose I/O
12, 13	P32, P33	D	General purpose I/O
14	P34	D	General purpose I/O
	SOT0		SOT output for UART 0. To enable the signal output, the corresponding bit of the Port Direction register should be set to "1".
15	P35	D	General purpose I/O
	SCK0		SCK input/output for UART 0. To enable the signal output, the corresponding bit of the Port Direction register should be set to "1".

(Continued)

MB90590G Series

No.	Pin name	Circuit type	Function
16	P36	D	General purpose I/O
	SIN0		SIN input for UART 0
17	P37	D	General purpose I/O
	SIN1		SIN input for UART 1
18	P40	D	General purpose I/O
	SCK1		SCK input/output for UART 1
19	P41	D	General purpose I/O
	SOT1		SOT output for UART 1
20	P42	D	General purpose I/O
	SOT2		SOT output for UART 2
21	P43	D	General purpose I/O
	SCK2		SCK input/output for UART 2
22	P44	D	General purpose I/O
	SIN2		SIN input for UART 2
24	P45	D	General purpose I/O
	SIN3		SIN input for the Serial I/O
25	P46	D	General purpose I/O
	SCK3		SCK input/output for the Serial I/O
26	P47	D	General purpose I/O
	SOT3		SOT output for the Serial I/O
28 to 33	P50 to P55	D	General purpose I/O
	PPG0 to PPG5, ADTG		Outputs for the Programmable Pulse Generators. Pin number 33 is also shared with ADTG input for the external trigger of the A/D Converter.
38 to 41	P60 to P63	E	General purpose I/O
	AN0 to AN3		Inputs for the A/D Converter
43 to 46	P64 to P67	E	General purpose I/O
	AN4 to AN7		Inputs for the A/D Converter
47	P56	D	General purpose I/O
	TIN		TIN input for the 16-bit Reload Timers
48	P57	D	General purpose I/O
	TOT/WOT		TOT output for the 16-bit Reload Timers and WOT output for the Watch Timer. Only one of three output enable flags in these peripheral blocks can be set at a time. Otherwise the output signal has no meaning.

(Continued)

MB90590G Series

No.	Pin name	Circuit type	Function
54 to 57	P70 to P73	F	General purpose I/O
	PWM1P0, PWM1M0, PWM2P0, PWM2M0		Output for Stepping Motor Controller channel 0.
59 to 62	P74 to P77	F	General purpose I/O
	PWM1P1, PWM1M1, PWM2P1, PWM2M1		Output for Stepping Motor Controller channel 1.
64 to 67	P80 to P83	F	General purpose I/O
	PWM1P2, PWM1M2, PWM2P2, PWM2M2		Output for Stepping Motor Controller channel 2.
69 to 72	P84 to P87	F	General purpose I/O
	PWM1P3, PWM1M3, PWM2P3, PWM2M3		Output for Stepping Motor Controller channel 3.
74	P90	D	General purpose I/O
	TX0		TX output for CAN Interface 0
75	P91	D	General purpose I/O
	RX0		RX input for CAN Interface 0
76	P92	D	General purpose I/O
	INT0		External interrupt input for INT0
78	P93	D	General purpose I/O
	INT1		External interrupt input for INT1
79	P94	D	General purpose I/O
	INT2		External interrupt input for INT2
80	P95	D	General purpose I/O
	INT3		External interrupt input for INT3
58, 68	DV _{cc}	—	Dedicated power supply pins for the high current output buffers (Pin No. 54 to 72)
53, 63, 73	DV _{ss}	—	Dedicated ground pins for the high current output buffers (Pin No. 54 to 72)
34	AV _{cc}	Power supply	Power supply for analog circuit pin When turning this power supply on or off, always be sure to first apply electric potential equal to or greater than AV _{cc} to V _{cc} .
37	AV _{ss}	Power supply	Ground level for analog circuit

(Continued)

MB90590G Series

(Continued)

No.	Pin name	Circuit type	Function
35	AVRH	Power supply	Reference voltage input pin for analog circuit When turning this power supply on or off, always be sure to first apply electric potential equal to or greater than AVRH to AV _{CC} .
36	AVRL	Power supply	Reference voltage input pin for analog circuit
49, 50	MD0, MD1	C	Operating mode selection input pins Connect directly to V _{CC} or V _{SS} .
51	MD2	G	Operating mode selection input pin Connect directly to V _{CC} or V _{SS} .
27	C	—	This is the power supply stabilization capacitor pin. It should be connected externally to an 0.1 μF ceramic capacitor.
23, 84	V _{CC}	Power supply	Power supply (5.0 V) input pin for digital circuit
11,42,81	V _{SS}	Power supply	Power supply (GND) input pin for digital circuit

■ I/O CIRCUIT TYPE

Circuit Type	Circuit	Remarks
A		<ul style="list-style-type: none"> Oscillation feedback resistor : 1 MΩ approx.
B		<ul style="list-style-type: none"> Hysteresis input with pull-up resistor : 50 kΩ approx.
C		<ul style="list-style-type: none"> Hysteresis input
D		<ul style="list-style-type: none"> CMOS output Hysteresis input

(Continued)

MB90590G Series

(Continued)

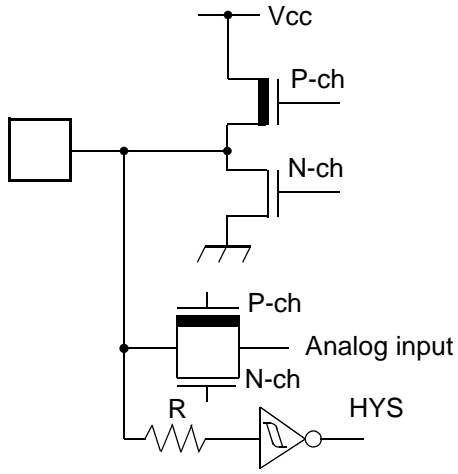
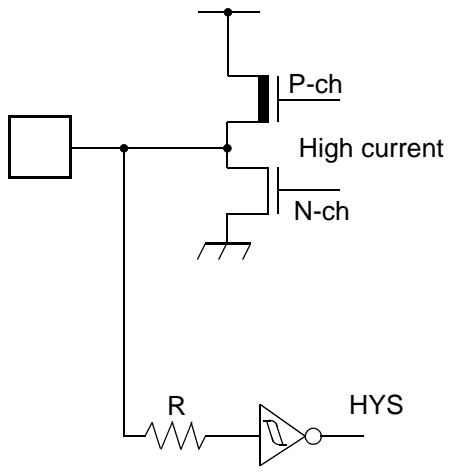
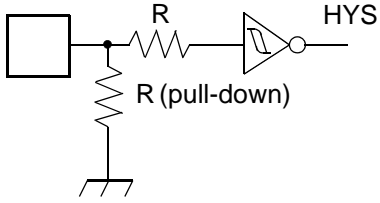
Circuit Type	Circuit	Remarks
E	 <p>The diagram shows a CMOS output stage with a P-channel MOSFET (P-ch) connected to Vcc and an N-channel MOSFET (N-ch) connected to ground. The gates of both are connected to a square wave input. Below this, there is an analog input stage with a P-channel MOSFET (P-ch) and an N-channel MOSFET (N-ch). The gates of both are connected to a square wave input. A resistor R is connected between the gates of the P-ch and N-ch MOSFETs. The output of the N-ch MOSFET is connected to a hysteresis input (HYS) of a comparator.</p>	<ul style="list-style-type: none"> • CMOS output • Hysteresis input • Analog input
F	 <p>The diagram shows a CMOS high current output stage with a P-channel MOSFET (P-ch) connected to Vcc and an N-channel MOSFET (N-ch) connected to ground. The gates of both are connected to a square wave input. Below this, there is a resistor R connected between the gates of the P-ch and N-ch MOSFETs. The output of the N-ch MOSFET is connected to a hysteresis input (HYS) of a comparator.</p>	<ul style="list-style-type: none"> • CMOS high current output • Hysteresis input
G	 <p>The diagram shows a hysteresis input (HYS) of a comparator. A resistor R is connected between the HYS input and a square wave input. A pull-down resistor R (pull-down) is connected between the HYS input and ground.</p>	<ul style="list-style-type: none"> • Hysteresis input with pull-down resistor : 50 kΩ approx. • Flash version does not have pull-down resistor.

■ HANDLING DEVICES

(1) Preventing latch-up

CMOS IC chips may suffer latch-up under the following conditions :

- A voltage higher than V_{cc} or lower than V_{ss} is applied to an input or output pin.
- A voltage higher than the rated voltage is applied between V_{cc} and V_{ss} .
- The AV_{cc} power supply is applied before the V_{cc} voltage.

Latch-up may increase the power supply current drastically, causing thermal damage to the device.

For the same reason, also be careful not to let the analog power-supply voltage (AV_{cc} , AV_{RH}) exceed the digital power-supply voltage.

(2) Treatment of unused pins

Leaving unused input pins open may result in misbehavior or latch up and possible permanent damage of the device. Therefore they must be pulled up or pulled down through resistors. In this case those resistors should be more than $2\text{ k}\Omega$.

Unused bidirectional pins should be set to the output state and can be left open, or the input state with the above described connection.

(3) Using external clock

To use external clock, drive X0 pin only and leave X1 pin unconnected.

Below is a diagram of how to use external clock.

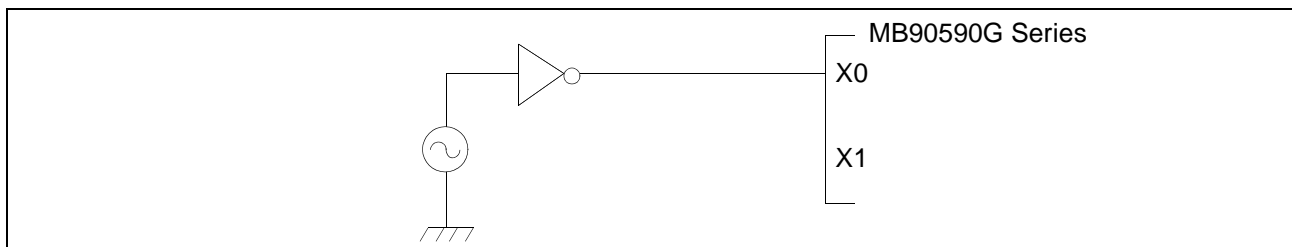

Using external clock

MB90590G Series

(4) Power supply pins (V_{CC}/V_{SS})

In products with multiple V_{CC} or V_{SS} pins, pins with the same potential are internally connected in the device to avoid abnormal operations including latch-up. However, you must connect the pins to an external power and a ground line to lower the electro-magnetic emission level to prevent abnormal operation of strobe signals caused by the rise in the ground level, and to conform to the total current rating.

Make sure to connect V_{CC} and V_{SS} pins via lowest impedance to power lines.

It is recommended to provide a bypass capacitor of around 0.1 μF between V_{CC} and V_{SS} pin near the device.

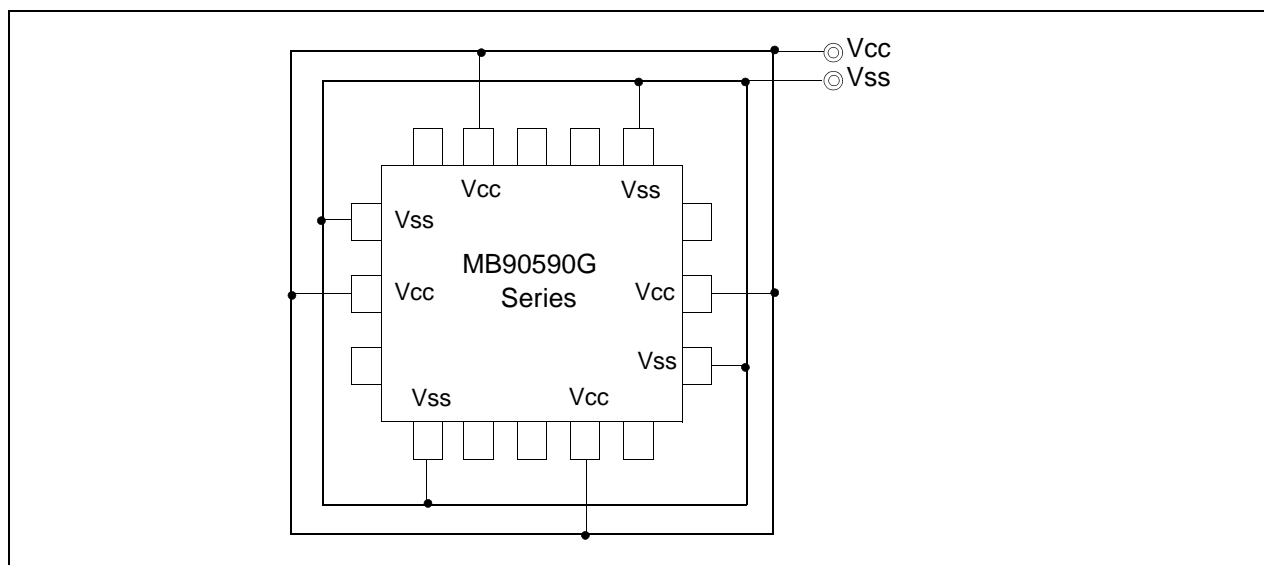

(5) Pull-up/down resistors

The MB90590G Series does not support internal pull-up/down resistors. Use external components where needed.

(6) Crystal Oscillator Circuit

Noises around X0 or X1 pins may cause abnormal operations. Make sure to provide bypass capacitors via the shortest distances from X0, X1 pins, crystal oscillator (or ceramic resonator) and ground lines, and make sure that lines of oscillation circuits do not cross the lines of other circuits.

A printed circuit board artwork surrounding the X0 and X1 pins with a ground area for stabilizing the operation is highly recommended.

(7) Turning-on Sequence of Power Supply to A/D Converter and Analog Inputs

Make sure to turn on the A/D converter power supply (AV_{CC}, AVR_H, AVR_L) and analog inputs (AN0 to AN7) after turning-on the digital power supply (V_{CC}).

Turn-off the digital power after turning off the A/D converter supply and analog inputs. In this case, make sure that the voltage does not exceed AVR_H or AV_{CC} (turning on/off the analog and digital power supplies simultaneously is acceptable).

(8) Connection of Unused Pins of A/D Converter

Connect unused pins of A/D converter to AV_{CC} = V_{CC}, AV_{SS} = AVR_H = V_{SS}.

(9) N.C. Pin

The N.C. (internally connected) pin must be opened for use.

(10) Notes on Energization

To prevent the internal regulator circuit from malfunctioning, set the voltage rise time during energization at 50 μ s or more (0.2 V to 2.7 V).

(11) Indeterminate outputs from ports 0 and 1 (without MB90F591G/591G, MB90F594G)

During oscillation setting time of step-down circuit (during a power-on reset) after the power is turned on, the outputs from ports 0 and 1 become following state.

- If RST pin is "H", the outputs become indeterminate.
- If RST pin is "L", the outputs become high-impedance.

Pay attention to the port output timing shown as follow.

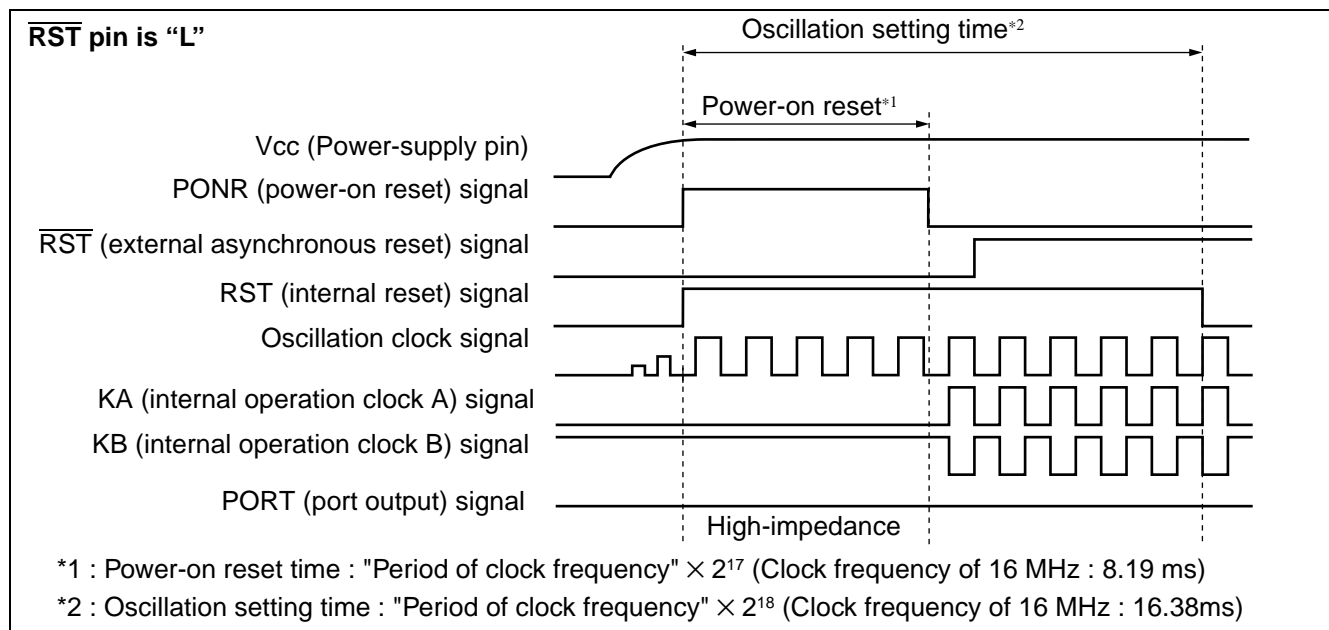
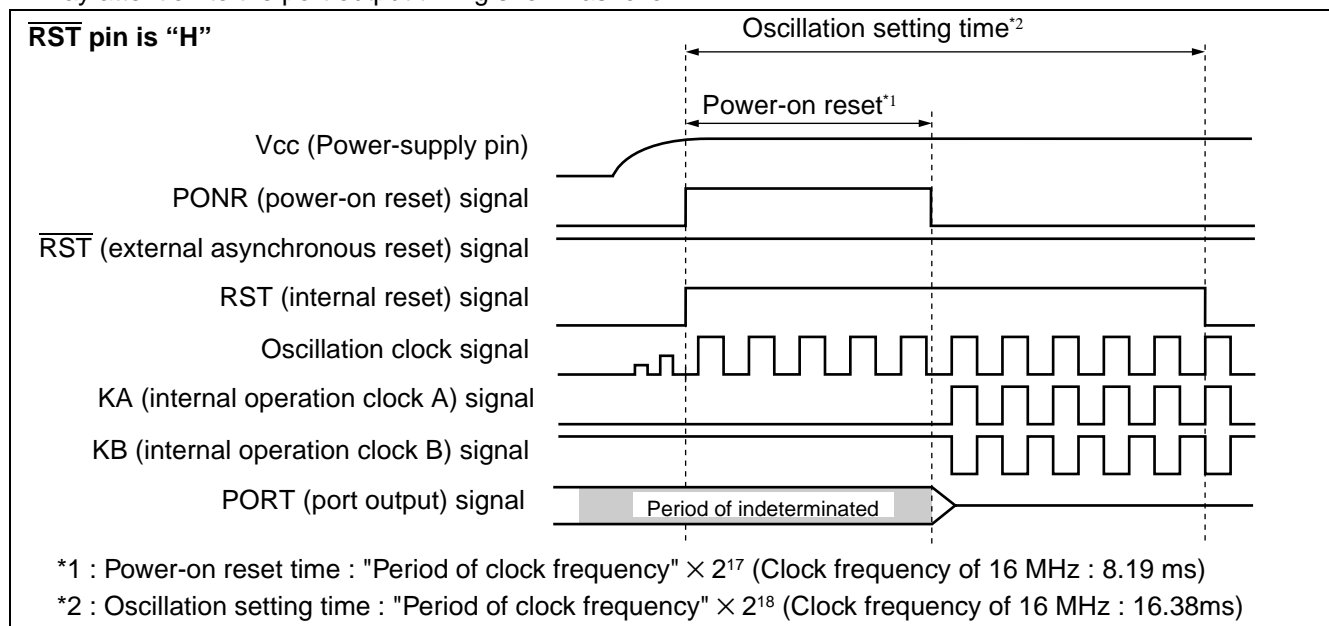

(12) Initialization

The device contains internal registers which are initialized only by a power-on reset. To initialize these registers, please turn on the power again.

(13) Directions of “DIV A, Ri” and “DIVW A, RWi” instructions

In the Signed multiplication and division instructions (“DIV A, Ri” and “DIVW A, RWi”), the value of the corresponding bank register (DTB, ADB, USB, SSB) is set in “00 H”.

If the values of the corresponding bank registers (DTB,ADB,USB,SSB) are set to other than “00 H”, the remainder by the execution result of the instruction is not stored in the register of the instruction operand.

(14) Using REALOS

The use of EI²OS is not possible with the REALOS real time operating system.

(15) Caution on Operations during PLL Clock Mode

If the PLL clock mode is selected in the microcontroller, it may attempt to continue the operation using the free-running frequency of the automatic oscillating circuit in the PLL circuitry even if the oscillator is out of place or the clock input is stopped. Performance of this operation, however, cannot be guaranteed.

■ BLOCK DIAGRAM

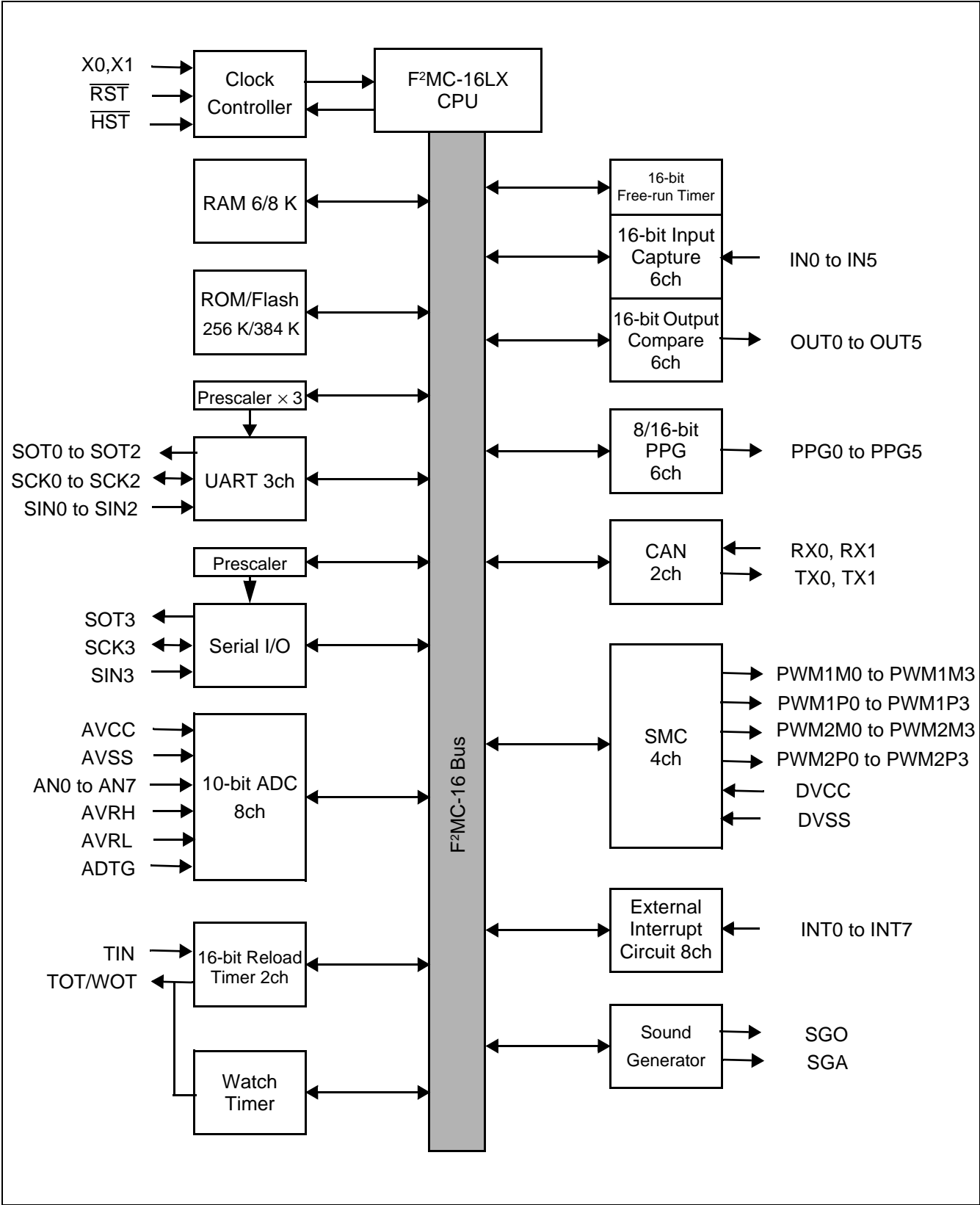

MB90590G Series

■ MEMORY SPACE

The memory space of the MB90590/590G Series is shown below

	MB90V590G		MB90594G/F594G		MB90591G/ F591G
FFFFFF _H FF0000 _H	ROM (FF bank)	FFFFFF _H FF0000 _H	ROM (FF bank)	FFFFFF _H FF0000 _H	ROM (FF bank)
FEFFFF _H FE0000 _H	ROM (FE bank)	FEFFFF _H FE0000 _H	ROM (FE bank)	FEFFFF _H FE0000 _H	ROM (FE bank)
FDFFFF _H FD0000 _H	ROM (FD bank)	FDFFFF _H FD0000 _H	ROM (FD bank)	FDFFFF _H FD0000 _H	ROM (FD bank)
FCFFFF _H FC0000 _H	ROM (FC bank)	FCFFFF _H FC0000 _H	ROM (FC bank)	FCFFFF _H FC0000 _H	
FBFFFF _H FB0000 _H	ROM (FB bank)			FBFFFF _H FB0000 _H	ROM (FB bank)
FAFFFF _H FA0000 _H	ROM (FA bank)			FAFFFF _H FA0000 _H	ROM (FA bank)
F9FFFF _H F90000 _H	ROM (F9 bank)			F9FFFF _H F90000 _H	ROM (F9 bank)
00FFFF _H 004000 _H	ROM (Image of FF bank)	00FFFF _H 004000 _H	ROM (Image of FF bank)	00FFFF _H 004000 _H	ROM (Image of FF bank)
0028FF _H 002100 _H 0020FF _H	RAM 2K			0028FF _H 002100 _H 0020FF _H	RAM 2K
001FFF _H 001900 _H 0018FF _H	Peripheral	001FFF _H 001900 _H 0018FF _H	Peripheral	001FFF _H 001900 _H 0018FF _H	Peripheral
	RAM 6K		RAM 6K		RAM 6K
000100 _H		000100 _H		000100 _H	
0000BF _H 000000 _H	Peripheral	0000BF _H 000000 _H	Peripheral	0000BF _H 000000 _H	Peripheral

Memory space map

Note : The ROM data of bank FF is reflected in the upper address of bank 00, realizing effective use of the C compiler small model. The lower 16-bit of bank FF and the lower 16-bit of bank 00 are assigned to the same address, enabling reference of the table on the ROM without stating "far".

For example, if an attempt has been made to access 00C000_H, the contents of the ROM at FFC000_H are accessed. Since the ROM area of the FF bank exceeds 48 Kbytes, the whole area cannot be reflected in the image for the 00 bank. The ROM data at FF4000_H to FFFFFFF_H looks, therefore, as if it were the image for 004000_H to 00FFFF_H. Thus, it is recommended that the ROM data table be stored in the area of FF4000_H to FFFFFFF_H.

■ I/O MAP

Address	Register	Abbreviation	Access	Peripheral	Initial value
00H	Port 0 Data Register	PDR0	R/W	Port 0	XXXXXXXX _B
01H	Port 1 Data Register	PDR1	R/W	Port 1	XXXXXXXX _B
02H	Port 2 Data Register	PDR2	R/W	Port 2	XXXXXXXX _B
03H	Port 3 Data Register	PDR3	R/W	Port 3	XXXXXXXX _B
04H	Port 4 Data Register	PDR4	R/W	Port 4	XXXXXXXX _B
05H	Port 5 Data Register	PDR5	R/W	Port 5	XXXXXXXX _B
06H	Port 6 Data Register	PDR6	R/W	Port 6	XXXXXXXX _B
07H	Port 7 Data Register	PDR7	R/W	Port 7	XXXXXXXX _B
08H	Port 8 Data Register	PDR8	R/W	Port 8	XXXXXXXX _B
09H	Port 9 Data Register	PDR9	R/W	Port 9	__ XXXXXX _B
0AH to 0FH	Reserved				
10H	Port 0 Direction Register	DDR0	R/W	Port 0	0 0 0 0 0 0 0 0 _B
11H	Port 1 Direction Register	DDR1	R/W	Port 1	0 0 0 0 0 0 0 0 _B
12H	Port 2 Direction Register	DDR2	R/W	Port 2	0 0 0 0 0 0 0 0 _B
13H	Port 3 Direction Register	DDR3	R/W	Port 3	0 0 0 0 0 0 0 0 _B
14H	Port 4 Direction Register	DDR4	R/W	Port 4	0 0 0 0 0 0 0 0 _B
15H	Port 5 Direction Register	DDR5	R/W	Port 5	0 0 0 0 0 0 0 0 _B
16H	Port 6 Direction Register	DDR6	R/W	Port 6	0 0 0 0 0 0 0 0 _B
17H	Port 7 Direction Register	DDR7	R/W	Port 7	0 0 0 0 0 0 0 0 _B
18H	Port 8 Direction Register	DDR8	R/W	Port 8	0 0 0 0 0 0 0 0 _B
19H	Port 9 Direction Register	DDR9	R/W	Port 9	__ 0 0 0 0 0 0 _B
1AH	Reserved				
1BH	Analog Input Enable Register	ADER	R/W	Port 6, A/D	1 1 1 1 1 1 1 1 _B
1CH to 1FH	Reserved				
20H	Serial Mode Control Register 0	UMC0	R/W	UART0	0 0 0 0 0 1 0 0 _B
21H	Serial Status Register 0	USR0	R/W		0 0 0 1 0 0 0 0 _B
22H	Serial Input/Output Data Register 0	UIDR0/ UODR0	R/W		XXXXXXXX _B
23H	Rate and Data Register 0	URD0	R/W		0 0 0 0 0 0 0 X _B
24H	Serial Mode Control Register 1	UMC1	R/W	UART1	0 0 0 0 0 1 0 0 _B
25H	Serial Status Register 1	USR1	R/W		0 0 0 1 0 0 0 0 _B
26H	Serial Input/Output Data Register 1	UIDR1/ UODR1	R/W		XXXXXXXX _B
27H	Rate and Data Register 1	URD1	R/W		0 0 0 0 0 0 0 X _B

(Continued)

MB90590G Series

Address	Register	Abbreviation	Access	Peripheral	Initial value
28H	Serial Mode Control Register 2	UMC2	R/W	UART2	0 0 0 0 0 1 0 0 _B
29H	Serial Status Register 2	USR2	R/W		0 0 0 1 0 0 0 0 _B
2AH	Serial Input/Output Data Register 2	UIDR2/ UODR2	R/W		XXXXXXXX _B
2BH	Rate and Data Register 2	URD2	R/W		0 0 0 0 0 0 0 X _B
2CH	Serial Mode Control Register (low-order)	SMCS	R/W	Serial I/O	____0 0 0 0 _B
2DH	Serial Mode Control Register (high-order)	SMCS	R/W		0 0 0 0 0 0 1 0 _B
2EH	Serial Data Register	SDR	R/W		XXXXXXXX _B
2FH	Edge Selector Register	SES	R/W		_____ _B
30H	External Interrupt Enable Register	ENIR	R/W	External Interrupt	0 0 0 0 0 0 0 0 _B
31H	External Interrupt Request Register	EIRR	R/W		XXXXXXXX _B
32H	External Interrupt Level Register	ELVR	R/W		0 0 0 0 0 0 0 0 _B
33H	External Interrupt Level Register	ELVR	R/W		0 0 0 0 0 0 0 0 _B
34H	A/D Control Status Register 0	ADCS0	R/W	A/D Converter	0 0 0 0 0 0 0 0 _B
35H	A/D Control Status Register 1	ADCS1	R/W		0 0 0 0 0 0 0 0 _B
36H	A/D Data Register 0	ADCR0	R		XXXXXXXX _B
37H	A/D Data Register 1	ADCR1	R/W		0 0 0 0 1 0 XX _B
38H	PPG0 Operation Mode Control Register	PPGC0	R/W	16-bit Programmable Pulse Generator 0/1	0 _ 0 0 0 _ _ 1 _B
39H	PPG1 Operation Mode Control Register	PPGC1	R/W		0 _ 0 0 0 0 0 1 _B
3AH	PPG0,1 Output Pin Control Register	PPG01	R/W		0 0 0 0 0 0 0 0 _B
3BH	Reserved				
3CH	PPG2 Operation Mode Control Register	PPGC2	R/W	16-bit Programmable Pulse Generator 2/3	0 _ 0 0 0 _ _ 1 _B
3DH	PPG3 Operation Mode Control Register	PPGC3	R/W		0 _ 0 0 0 0 0 1 _B
3EH	PPG2,3 Output Pin Control Register	PPG23	R/W		0 0 0 0 0 0 0 0 _B
3FH	Reserved				
40H	PPG4 Operation Mode Control Register	PPGC4	R/W	16-bit Programmable Pulse Generator 4/5	0 _ 0 0 0 _ _ 1 _B
41H	PPG5 Operation Mode Control Register	PPGC5	R/W		0 _ 0 0 0 0 0 1 _B
42H	PPG4,5 Output Pin Control Register	PPG45	R/W		0 0 0 0 0 0 0 0 _B
43H	Reserved				
44H	PPG6 Operation Mode Control Register	PPGC6	R/W	16-bit Programmable Pulse Generator 6/7	0 _ 0 0 0 _ _ 1 _B
45H	PPG7 Operation Mode Control Register	PPGC7	R/W		0 _ 0 0 0 0 0 1 _B
46H	PPG6,7 Output Pin Control Register	PPG67	R/W		0 0 0 0 0 0 0 0 _B
47H	Reserved				

(Continued)

MB90590G Series

Address	Register	Abbreviation	Access	Peripheral	Initial value
48H	PPG8 Operation Mode Control Register	PPGC8	R/W	16-bit Programmable Pulse Generator 8/9	0_000__1B
49H	PPG9 Operation Mode Control Register	PPGC9	R/W		0_000001B
4AH	PPG8,9 Output Pin Control Register	PPG89	R/W		00000000B
4BH	Reserved				
4CH	PPGA Operation Mode Control Register	PPGCA	R/W	16-bit Programmable Pulse Generator A/B	0_000__1B
4DH	PPGB Operation Mode Control Register	PPGCB	R/W		0_000001B
4EH	PPGA,B Output Pin Control Register	PPGAB	R/W		00000000B
4FH	Reserved				
50H	Timer Control Status Register 0 (low-order)	TMCSR0	R/W	16-bit Reload Timer 0	00000000B
51H	Timer Control Status Register 0 (high-order)	TMCSR0	R/W		____0000B
52H	Timer Control Status Register 1 (low-order)	TMCSR1	R/W	16-bit Reload Timer 1	00000000B
53H	Timer Control Status Register 1 (high-order)	TMCSR1	R/W		____0000B
54H	Input Capture Control Status Register 0/1	ICS01	R/W	Input Capture 0/1	00000000B
55H	Input Capture Control Status Register 2/3	ICS23	R/W	Input Capture 2/3	00000000B
56H	Input Capture Control Status Register 4/5	ICS45	R/W	Input Capture 4/5	00000000B
57H	Reserved				
58H	Output Compare Control Status Register 0	OCS0	R/W	Output Compare 0/1	0000__00B
59H	Output Compare Control Status Register 1	OCS1	R/W		___00000B
5AH	Output Compare Control Status Register 2	OCS2	R/W	Output Compare 2/3	0000__00B
5BH	Output Compare Control Status Register 3	OCS3	R/W		___00000B
5CH	Output Compare Control Status Register 4	OCS4	R/W	Output Compare 4/5	0000__00B
5DH	Output Compare Control Status Register 5	OCS5	R/W		___00000B
5EH	Sound Control Register (low-order)	SGCR	R/W	Sound Generator	00000000B
5FH	Sound Control Register (high-order)	SGCR	R/W		0_____0B

(Continued)

MB90590G Series

Address	Register	Abbreviation	Access	Peripheral	Initial value
60H	Watch Timer Control Register (low-order)	WTCR	R/W	Watch Timer	0 0 0 _ _ 0 0 0 _B
61H	Watch Timer Control Register (high-order)	WTCR	R/W		0 0 0 0 0 0 0 0 _B
62H	PWM Control Register 0	PWC0	R/W	Stepping Motor Controller 0	0 0 0 0 0 _ _ 0 _B
63H	Reserved				
64H	PWM Control Register 1	PWC1	R/W	Stepping Motor Controller 1	0 0 0 0 0 _ _ 0 _B
65H	Reserved				
66H	PWM Control Register 2	PWC2	R/W	Stepping Motor Controller 2	0 0 0 0 0 _ _ 0 _B
67H	Reserved				
68H	PWM Control Register 3	PWC3	R/W	Stepping Motor Controller 3	0 0 0 0 0 _ _ 0 _B
69H to 6CH	Reserved				
6DH	Serial I/O Prescaler Register	CDCR	R/W	Prescaler (Serial I/O)	0 XXX 1 1 1 1 _B
6EH	Timer Control Status Register	TCCS	R/W	16-bit Free-run Timer	0 0 0 0 0 0 0 0 _B
6FH	ROM Mirror Function Select Register	ROMM	W	ROM Mirror	XXXXXXXX _{1B}
70H to 8FH	Reserved for CAN Interface 0/1. Refer to section about CAN Controller				
90H to 9DH	Reserved				
9EH	Program Address Detection Control Status Register	PACSR	R/W	Address Match Detection Function	0 0 0 0 0 0 0 0 _B
9FH	Delayed Interrupt/Release Register	DIRR	R/W	Delayed Interrupt	_ _ _ _ _ 0 _B
A0H	Low Power Mode Control Register	LPMCR	R/W	Low Power Controller	0 0 0 1 1 0 0 0 _B
A1H	Clock Selection Register	CKSCR	R/W	Low Power Controller	1 1 1 1 1 1 0 0 _B
A2H to A7H	Reserved				
A8H	Watchdog Timer Control Register	WDTC	R/W	Watchdog Timer	XXXXX 1 1 1 _B
A9H	Time Base Timer Control Register	TBTC	R/W	Time Base Timer	1 - - 0 0 1 0 0 _B
AAH to ADH	Reserved				
AEH	Flash Memory Control Status Register (Flash product only. Otherwise reserved)	FMCS	R/W	Flash Memory	0 0 0 X 0 0 0 0 _B
AFH	Reserved				

(Continued)

MB90590G Series

Address	Register	Abbreviation	Access	Peripheral	Initial value
B0 _H	Interrupt Control Register 00	ICR00	R/W	Interrupt controller	0 0 0 0 0 1 1 1 _B
B1 _H	Interrupt Control Register 01	ICR01	R/W		0 0 0 0 0 1 1 1 _B
B2 _H	Interrupt Control Register 02	ICR02	R/W		0 0 0 0 0 1 1 1 _B
B3 _H	Interrupt Control Register 03	ICR03	R/W		0 0 0 0 0 1 1 1 _B
B4 _H	Interrupt Control Register 04	ICR04	R/W		0 0 0 0 0 1 1 1 _B
B5 _H	Interrupt Control Register 05	ICR05	R/W		0 0 0 0 0 1 1 1 _B
B6 _H	Interrupt Control Register 06	ICR06	R/W		0 0 0 0 0 1 1 1 _B
B7 _H	Interrupt Control Register 07	ICR07	R/W		0 0 0 0 0 1 1 1 _B
B8 _H	Interrupt Control Register 08	ICR08	R/W		0 0 0 0 0 1 1 1 _B
B9 _H	Interrupt Control Register 09	ICR09	R/W		0 0 0 0 0 1 1 1 _B
BA _H	Interrupt Control Register 10	ICR10	R/W		0 0 0 0 0 1 1 1 _B
BB _H	Interrupt Control Register 11	ICR11	R/W		0 0 0 0 0 1 1 1 _B
BC _H	Interrupt Control Register 12	ICR12	R/W		0 0 0 0 0 1 1 1 _B
BD _H	Interrupt Control Register 13	ICR13	R/W		0 0 0 0 0 1 1 1 _B
BE _H	Interrupt Control Register 14	ICR14	R/W		0 0 0 0 0 1 1 1 _B
BF _H	Interrupt Control Register 15	ICR15	R/W		0 0 0 0 0 1 1 1 _B
C0 _H to FF _H	Reserved				
1900 _H	Reload L Register	PRLLO	R/W	16-bit Programmable Pulse Generator 0/1	XXXXXXXX _B
1901 _H	Reload H Register	PRLH0	R/W		XXXXXXXX _B
1902 _H	Reload L Register	PRLLO1	R/W		XXXXXXXX _B
1903 _H	Reload H Register	PRLH1	R/W		XXXXXXXX _B
1904 _H	Reload L Register	PRLLO2	R/W	16-bit Programmable Pulse Generator 2/3	XXXXXXXX _B
1905 _H	Reload H Register	PRLH2	R/W		XXXXXXXX _B
1906 _H	Reload L Register	PRLLO3	R/W		XXXXXXXX _B
1907 _H	Reload H Register	PRLH3	R/W		XXXXXXXX _B
1908 _H	Reload L Register	PRLLO4	R/W	16-bit Programmable Pulse Generator 4/5	XXXXXXXX _B
1909 _H	Reload H Register	PRLH4	R/W		XXXXXXXX _B
190A _H	Reload L Register	PRLLO5	R/W		XXXXXXXX _B
190B _H	Reload H Register	PRLH5	R/W		XXXXXXXX _B
190C _H	Reload L Register	PRLLO6	R/W	16-bit Programmable Pulse Generator 6/7	XXXXXXXX _B
190D _H	Reload H Register	PRLH6	R/W		XXXXXXXX _B
190E _H	Reload L Register	PRLLO7	R/W		XXXXXXXX _B
190F _H	Reload H Register	PRLH7	R/W		XXXXXXXX _B

(Continued)

MB90590G Series

Address	Register	Abbreviation	Access	Peripheral	Initial value
1910 _H	Reload L Register	PRL8	R/W	16-bit Programmable Pulse Generator 8/9	XXXXXXXX _B
1911 _H	Reload H Register	PRLH8	R/W		XXXXXXXX _B
1912 _H	Reload L Register	PRL9	R/W		XXXXXXXX _B
1913 _H	Reload H Register	PRLH9	R/W		XXXXXXXX _B
1914 _H	Reload L Register	PRLA	R/W	16-bit Programmable Pulse Generator A/B	XXXXXXXX _B
1915 _H	Reload H Register	PRLHA	R/W		XXXXXXXX _B
1916 _H	Reload L Register	PRLB	R/W		XXXXXXXX _B
1917 _H	Reload H Register	PRLHB	R/W		XXXXXXXX _B
1918 _H to 191F _H	Reserved				
1920 _H	Input Capture Register 0 (low-order)	IPCP0	R	Input Capture 0/1	XXXXXXXX _B
1921 _H	Input Capture Register 0 (high-order)	IPCP0	R		XXXXXXXX _B
1922 _H	Input Capture Register 1 (low-order)	IPCP1	R		XXXXXXXX _B
1923 _H	Input Capture Register 1 (high-order)	IPCP1	R		XXXXXXXX _B
1924 _H	Input Capture Register 2 (low-order)	IPCP2	R	Input Capture 2/3	XXXXXXXX _B
1925 _H	Input Capture Register 2 (high-order)	IPCP2	R		XXXXXXXX _B
1926 _H	Input Capture Register 3 (low-order)	IPCP3	R		XXXXXXXX _B
1927 _H	Input Capture Register 3 (high-order)	IPCP3	R		XXXXXXXX _B
1928 _H	Input Capture Register 4 (low-order)	IPCP4	R	Input Capture 4/5	XXXXXXXX _B
1929 _H	Input Capture Register 4 (high-order)	IPCP4	R		XXXXXXXX _B
192A _H	Input Capture Register 5 (low-order)	IPCP5	R		XXXXXXXX _B
192B _H	Input Capture Register 5 (high-order)	IPCP5	R		XXXXXXXX _B
192C _H to 192F _H	Reserved				

(Continued)

MB90590G Series

Address	Register	Abbreviation	Access	Peripheral	Initial value
1930 _H	Output Compare Register 0 (low-order)	OCCP0	R/W	Output Compare 0/1	XXXXXXXX _B
1931 _H	Output Compare Register 0 (high-order)	OCCP0	R/W		XXXXXXXX _B
1932 _H	Output Compare Register 1 (low-order)	OCCP1	R/W		XXXXXXXX _B
1933 _H	Output Compare Register 1 (high-order)	OCCP1	R/W		XXXXXXXX _B
1934 _H	Output Compare Register 2 (low-order)	OCCP2	R/W	Output Compare 2/3	XXXXXXXX _B
1935 _H	Output Compare Register 2 (high-order)	OCCP2	R/W		XXXXXXXX _B
1936 _H	Output Compare Register 3 (low-order)	OCCP3	R/W		XXXXXXXX _B
1937 _H	Output Compare Register 3 (high-order)	OCCP3	R/W		XXXXXXXX _B
1938 _H	Output Compare Register 4 (low-order)	OCCP4	R/W	Output Compare 4/5	XXXXXXXX _B
1939 _H	Output Compare Register 4 (high-order)	OCCP4	R/W		XXXXXXXX _B
193A _H	Output Compare Register 5 (low-order)	OCCP5	R/W		XXXXXXXX _B
193B _H	Output Compare Register 5 (high-order)	OCCP5	R/W		XXXXXXXX _B
193C _H to 193F _H	Reserved				
1940 _H	Timer 0/Reload Register 0 (low-order)	TMR0/ TMRLR0	R/W	16-bit Reload Timer 0	XXXXXXXX _B
1941 _H	Timer 0/Reload Register 0 (high-order)	TMR0/ TMRLR0	R/W		XXXXXXXX _B
1942 _H	Timer 1/Reload Register 1 (low-order)	TMR1/ TMRLR1	R/W	16-bit Reload Timer 1	XXXXXXXX _B
1943 _H	Timer 1/Reload Register 1 (high-order)	TMR1/ TMRLR1	R/W		XXXXXXXX _B
1944 _H	Timer Data Register (low-order)	TCDT	R/W	16-bit Free-run Timer	00000000 _B
1945 _H	Timer Data Register (high-order)	TCDT	R/W		00000000 _B
1946 _H	Frequency Data Register	SGFR	R/W	Sound Generator	XXXXXXXX _B
1947 _H	Amplitude Data Register	SGAR	R/W		XXXXXXXX _B
1948 _H	Decrement Grade Register	SGDR	R/W		XXXXXXXX _B
1949 _H	Tone Count Register	SGTR	R/W		XXXXXXXX _B

(Continued)

MB90590G Series

Address	Register	Abbreviation	Access	Peripheral	Initial value
194A _H	Sub-second Data Register (low-order)	WTBR	R/W	Watch Timer	XXXXXXXX _B
194B _H	Sub-second Data Register (middle-order)	WTBR	R/W		XXXXXXXX _B
194C _H	Sub-second Data Register (high-order)	WTBR	R/W		___XXXX _B
194D _H	Second Data Register	WTSR	R/W		__00000 _B
194E _H	Minute Data Register	WTMR	R/W	Watch Timer	__00000 _B
194F _H	Hour Data Register	WTHR	R/W		___00000 _B
1950 _H	PWM1 Compare Register 0	PWC10	R/W	Stepping Motor Controller 0	XXXXXXXX _B
1951 _H	PWM2 Compare Register 0	PWC20	R/W		XXXXXXXX _B
1952 _H	PWM1 Select Register 0	PWS10	R/W		__00000 _B
1953 _H	PWM2 Select Register 0	PWS20	R/W		_000000 _B
1954 _H	PWM1 Compare Register 1	PWC11	R/W	Stepping Motor Controller 1	XXXXXXXX _B
1955 _H	PWM2 Compare Register 1	PWC21	R/W		XXXXXXXX _B
1956 _H	PWM1 Select Register 1	PWS11	R/W		__00000 _B
1957 _H	PWM2 Select Register 1	PWS21	R/W		_000000 _B
1958 _H	PWM1 Compare Register 2	PWC12	R/W	Stepping Motor Controller 2	XXXXXXXX _B
1959 _H	PWM2 Compare Register 2	PWC22	R/W		XXXXXXXX _B
195A _H	PWM1 Select Register 2	PWS12	R/W		__00000 _B
195B _H	PWM2 Select Register 2	PWS22	R/W		_000000 _B
195C _H	PWM1 Compare Register 3	PWC13	R/W	Stepping Motor Controller 3	XXXXXXXX _B
195D _H	PWM2 Compare Register 3	PWC23	R/W		XXXXXXXX _B
195E _H	PWM1 Select Register 3	PWS13	R/W		__00000 _B
195F _H	PWM2 Select Register 3	PWS23	R/W		_000000 _B
1960 _H to 19FF _H	Reserved				
1A00 _H to 1AFF _H	CAN Interface 0. Refer to section about CAN Controller				
1B00 _H to 1BFF _H	CAN Interface 1. Refer to section about CAN Controller				
1C00 _H to 1CFF _H	CAN Interface 0. Refer to section about CAN Controller				
1D00 _H to 1DFF _H	CAN Interface 1. Refer to section about CAN Controller				
1E00 _H to 1EFF _H	Reserved				

(Continued)

(Continued)

Address	Register	Abbreviation	Access	Peripheral	Initial value
1FF0 _H	Program Address Detection Register 0 (low-order)	PADR0	R/W	Address Match Detection Function	XXXXXXXX _B
1FF1 _H	Program Address Detection Register 0 (middle-order)	PADR0	R/W		XXXXXXXX _B
1FF2 _H	Program Address Detection Register 0 (high-order)	PADR0	R/W		XXXXXXXX _B
1FF3 _H	Program Address Detection Register 1 (low-order)	PADR1	R/W		XXXXXXXX _B
1FF4 _H	Program Address Detection Register 1 (middle-order)	PADR1	R/W		XXXXXXXX _B
1FF5 _H	Program Address Detection Register 1 (high-order)	PADR1	R/W		XXXXXXXX _B
1FF6 _H to 1FFF _H	Reserved				

Note : Initial value of “_” represents unused bit; “X” represents unknown value.

Addresses in the range 0000_H to 00FF_H, which are not listed in the table, are reserved for the primary functions of the MCU. A read access to these reserved addresses results in reading “X”, and any write access should not be performed.

MB90590G Series

■ CAN CONTROLLERS

The CAN controller has the following features : Conforms to CAN Specification Version 2.0 Part A and B

- Supports transmission/reception in standard frame and extended frame formats
- Supports transmission of data frames by receiving remote frames
- 16 transmitting/receiving message buffers
 - 29-bit ID and 8-byte data
 - Multi-level message buffer configuration
- Provides full-bit comparison, full-bit mask, acceptance register 0/acceptance register 1 for each message buffer as 1D acceptance mask
 - Two acceptance mask registers in either standard frame format or extended frame formats
- Bit rate programmable from 10 Kbit/s to 2 Mbit/s (when input clock is at 16 MHz)

List of Control Registers

Address		Register	Abbreviation	Access	Initial Value
CAN0	CAN1				
000070 _H	000080 _H	Message buffer valid register	BVALR	R/W	00000000 00000000 _B
000071 _H	000081 _H				
000072 _H	000082 _H	Transmit request register	TREQR	R/W	00000000 00000000 _B
000073 _H	000083 _H				
000074 _H	000084 _H	Transmit cancel register	TCANR	W	00000000 00000000 _B
000075 _H	000085 _H				
000076 _H	000086 _H	Transmit complete register	TCR	R/W	00000000 00000000 _B
000077 _H	000087 _H				
000078 _H	000088 _H	Receive complete register	RCR	R/W	00000000 00000000 _B
000079 _H	000089 _H				
00007A _H	00008A _H	Remote request receiving register	RRTRR	R/W	00000000 00000000 _B
00007B _H	00008B _H				
00007C _H	00008C _H	Receive overrun register	ROVRR	R/W	00000000 00000000 _B
00007D _H	00008D _H				
00007E _H	00008E _H	Receive interrupt enable register	RIER	R/W	00000000 00000000 _B
00007F _H	00008F _H				

(Continued)

(Continued)

List of Control Registers

Address		Register	Abbreviation	Access	Initial Value
CAN0	CAN1				
001C00H	001D00H	Control status register	CSR	R/W, R	00---000 0----0-1 _B
001C01H	001D01H				
001C02H	001D02H	Last event indicator register	LEIR	R/W	----- 000-0000 _B
001C03H	001D03H				
001C04H	001D04H	Receive/transmit error counter	RTEC	R	00000000 00000000 _B
001C05H	001D05H				
001C06H	001D06H	Bit timing register	BTR	R/W	-1111111 11111111 _B
001C07H	001D07H				
001C08H	001D08H	IDE register	IDER	R/W	XXXXXXXX XXXXXXXX _B
001C09H	001D09H				
001C0AH	001D0AH	Transmit RTR register	TRTRR	R/W	00000000 00000000 _B
001C0BH	001D0BH				
001C0CH	001D0CH	Remote frame receive waiting register	RFWTR	R/W	XXXXXXXX XXXXXXXX _B
001C0DH	001D0DH				
001C0EH	001D0EH	Transmit interrupt enable register	TIER	R/W	00000000 00000000 _B
001C0FH	001D0FH				
001C10H	001D10H	Acceptance mask select register	AMSR	R/W	XXXXXXXX XXXXXXXX _B
001C11H	001D11H				
001C12H	001D12H				XXXXXXXX XXXXXXXX _B
001C13H	001D13H				
001C14H	001D14H	Acceptance mask register 0	AMR0	R/W	XXXXXXXX XXXXXXXX _B
001C15H	001D15H				
001C16H	001D16H				XXXXX--- XXXXXXXX _B
001C17H	001D17H				
001C18H	001D18H	Acceptance mask register 1	AMR1	R/W	XXXXXXXX XXXXXXXX _B
001C19H	001D19H				
001C1AH	001D1AH				XXXXX--- XXXXXXXX _B
001C1BH	001D1BH				

MB90590G Series

List of Message Buffers (ID Registers)

Address		Register	Abbreviation	Access	Initial Value
CAN0	CAN1				
001A20H	001B20H	ID register 0	IDR0	R/W	XXXXXXXX XXXXXXXXB
001A21H	001B21H				XXXXX--- XXXXXXXXB
001A22H	001B22H				
001A23H	001B23H				
001A24H	001B24H	ID register 1	IDR1	R/W	XXXXXXXX XXXXXXXXB
001A25H	001B25H				XXXXX--- XXXXXXXXB
001A26H	001B26H				
001A27H	001B27H				
001A28H	001B28H	ID register 2	IDR2	R/W	XXXXXXXX XXXXXXXXB
001A29H	001B29H				XXXXX--- XXXXXXXXB
001A2AH	001B2AH				
001A2BH	001B2BH				
001A2CH	001B2CH	ID register 3	IDR3	R/W	XXXXXXXX XXXXXXXXB
001A2DH	001B2DH				XXXXX--- XXXXXXXXB
001A2EH	001B2EH				
001A2FH	001B2FH				
001A30H	001B30H	ID register 4	IDR4	R/W	XXXXXXXX XXXXXXXXB
001A31H	001B31H				XXXXX--- XXXXXXXXB
001A32H	001B32H				
001A33H	001B33H				
001A34H	001B34H	ID register 5	IDR5	R/W	XXXXXXXX XXXXXXXXB
001A35H	001B35H				XXXXX--- XXXXXXXXB
001A36H	001B36H				
001A37H	001B37H				
001A38H	001B38H	ID register 6	IDR6	R/W	XXXXXXXX XXXXXXXXB
001A39H	001B39H				XXXXX--- XXXXXXXXB
001A3AH	001B3AH				
001A3BH	001B3BH				
001A3CH	001B3CH	ID register 7	IDR7	R/W	XXXXXXXX XXXXXXXXB
001A3DH	001B3DH				XXXXX--- XXXXXXXXB
001A3EH	001B3EH				
001A3FH	001B3FH				

(Continued)

MB90590G Series

(Continued)

Address		Register	Abbreviation	Access	Initial Value
CAN0	CAN1				
001A40 _H	001B40 _H	ID register 8	IDR8	R/W	XXXXXXXX XXXXXXXX _B
001A41 _H	001B41 _H				XXXXX--- XXXXXXXX _B
001A42 _H	001B42 _H				
001A43 _F	001B43 _H				
001A44 _H	001B44 _H	ID register 9	IDR9	R/W	XXXXXXXX XXXXXXXX _B
001A45 _H	001B45 _H				XXXXX--- XXXXXXXX _B
001A46 _H	001B46 _H				
001A47 _H	001B47 _H				
001A48 _H	001B48 _H	ID register 10	IDR10	R/W	XXXXXXXX XXXXXXXX _B
001A49 _H	001B49 _H				XXXXX--- XXXXXXXX _B
001A4A _H	001B4A _H				
001A4B _H	001B4B _H				
001A4C _H	001B4C _H	ID register 11	IDR11	R/W	XXXXXXXX XXXXXXXX _B
001A4D _H	001B4D _H				XXXXX--- XXXXXXXX _B
001A4E _H	001B4E _H				
001A4F _H	001B4F _H				
001A50 _H	001B50 _H	ID register 12	IDR12	R/W	XXXXXXXX XXXXXXXX _B
001A51 _H	001B51 _H				XXXXX--- XXXXXXXX _B
001A52 _H	001B52 _H				
001A53 _H	001B53 _H				
001A54 _H	001B54 _H	ID register 13	IDR13	R/W	XXXXXXXX XXXXXXXX _B
001A55 _H	001B55 _H				XXXXX--- XXXXXXXX _B
001A56 _H	001B56 _H				
001A57 _H	001B57 _H				
001A58 _H	001B58 _H	ID register 14	IDR14	R/W	XXXXXXXX XXXXXXXX _B
001A59 _H	001B59 _H				XXXXX--- XXXXXXXX _B
001A5A _H	001B5A _H				
001A5B _H	001B5B _H				
001A5C _H	001B5C _H	ID register 15	IDR15	R/W	XXXXXXXX XXXXXXXX _B
001A5D _H	001B5D _H				XXXXX--- XXXXXXXX _B
001A5E _H	001B5E _H				
001A5F _H	001B5F _H				

MB90590G Series

List of Message Buffers (DLC Registers and Data Registers)

Address		Register	Abbreviation	Access	Initial Value
CAN0	CAN1				
001A60H	001B60H	DLC register 0	DLCR0	R/W	----XXXX _B
001A61H	001B61H				
001A62H	001B62H	DLC register 1	DLCR1	R/W	----XXXX _B
001A63H	001B63H				
001A64H	001B64H	DLC register 2	DLCR2	R/W	----XXXX _B
001A65H	001B65H				
001A66H	001B66H	DLC register 3	DLCR3	R/W	----XXXX _B
001A67H	001B67H				
001A68H	001B68H	DLC register 4	DLCR4	R/W	----XXXX _B
001A69H	001B69H				
001A6AH	001B6AH	DLC register 5	DLCR5	R/W	----XXXX _B
001A6BH	001B6BH				
001A6CH	001B6CH	DLC register 6	DLCR6	R/W	----XXXX _B
001A6DH	001B6DH				
001A6EH	001B6EH	DLC register 7	DLCR7	R/W	----XXXX _B
001A6FH	001B6FH				
001A70H	001B70H	DLC register 8	DLCR8	R/W	----XXXX
001A71H	001B71H				
001A72H	001B72H	DLC register 9	DLCR9	R/W	----XXXX _B
001A73H	001B73H				
001A74H	001B74H	DLC register 10	DLCR10	R/W	----XXXX _B
001A75H	001B75H				
001A76H	001B76H	DLC register 11	DLCR11	R/W	----XXXX _B
001A77H	001B77H				
001A78H	001B78H	DLC register 12	DLCR12	R/W	----XXXX _B
001A79H	001B79H				
001A7AH	001B7AH	DLC register 13	DLCR13	R/W	----XXXX _B
001A7BH	001B7BH				
001A7CH	001B7CH	DLC register 14	DLCR14	R/W	----XXXX _B
001A7DH	001B7DH				
001A7EH	001B7EH	DLC register 15	DLCR15	R/W	----XXXX _B
001A7FH	001B7FH				
001A80H to 001A87H	001B80H to 001B87H	Data register 0 (8 bytes)	DTR0	R/W	XXXXXXXX _B to XXXXXXXX _B

(Continued)

MB90590G Series

(Continued)

Address		Register	Abbreviation	Access	Initial Value
CAN0	CAN1				
001A88 _H to 001A8F _H	001B88 _H to 001B8F _H	Data register 1 (8 bytes)	DTR1	R/W	XXXXXXXX _B to XXXXXXXX _B
001A90 _H to 001A97 _H	001B90 _H to 001B97 _H	Data register 2 (8 bytes)	DTR2	R/W	XXXXXXXX _B to XXXXXXXX _B
001A98 _H to 001A9F _H	001B98 _H to 001B9F _H	Data register 3 (8 bytes)	DTR3	R/W	XXXXXXXX _B to XXXXXXXX _B
001AA0 _H to 001AA7 _H	001BA0 _H to 001BA7 _H	Data register 4 (8 bytes)	DTR4	R/W	XXXXXXXX _B to XXXXXXXX _B
001AA8 _H to 001AAF _H	001BA8 _H to 001BAF _H	Data register 5 (8 bytes)	DTR5	R/W	XXXXXXXX _B to XXXXXXXX _B
001AB0 _H to 001AB7 _H	001BB0 _H to 001BB7 _H	Data register 6 (8 bytes)	DTR6	R/W	XXXXXXXX _B to XXXXXXXX _B
001AB8 _H to 001ABF _H	001BB8 _H to 001BBF _H	Data register 7 (8 bytes)	DTR7	R/W	XXXXXXXX _B to XXXXXXXX _B
001AC0 _H to 001AC7 _H	001BC0 _H to 001BC7 _H	Data register 8 (8 bytes)	DTR8	R/W	XXXXXXXX _B to XXXXXXXX _B
001AC8 _H to 001ACF _H	001BC8 _H to 001BCF _H	Data register 9 (8 bytes)	DTR9	R/W	XXXXXXXX _B to XXXXXXXX _B
001AD0 _H to 001AD7 _H	001BD0 _H to 001BD7 _H	Data register 10 (8 bytes)	DTR10	R/W	XXXXXXXX _B to XXXXXXXX _B
001AD8 _H to 001ADF _H	001BD8 _H to 001BDF _H	Data register 11 (8 bytes)	DTR11	R/W	XXXXXXXX _B to XXXXXXXX _B
001AE0 _H to 001AE7 _H	001BE0 _H to 001BE7 _H	Data register 12 (8 bytes)	DTR12	R/W	XXXXXXXX _B to XXXXXXXX _B
001AE8 _H to 001AEF _H	001BE8 _H to 001BEF _H	Data register 13 (8 bytes)	DTR13	R/W	XXXXXXXX _B to XXXXXXXX _B
001AF0 _H to 001AF7 _H	001BF0 _H to 001BF7 _H	Data register 14 (8 bytes)	DTR14	R/W	XXXXXXXX _B to XXXXXXXX _B
001AF8 _H to 001AFF _H	001BF8 _H to 001BFF _H	Data register 15 (8 bytes)	DTR15	R/W	XXXXXXXX _B to XXXXXXXX _B

MB90590G Series

■ INTERRUPT MAP

Interrupt cause	EI ^{POS} clear	Interrupt vector		Interrupt control register	
		Number	Address	Number	Address
Reset	N/A	# 08	FFFFDC _H	—	—
INT9 instruction	N/A	# 09	FFFFD8 _H	—	—
Exception	N/A	# 10	FFFFD4 _H	—	—
Time Base Timer	N/A	# 11	FFFFD0 _H	ICR00	0000B0 _H
External Interrupt (INT0 to INT7)	*1	# 12	FFFFCC _H		
CAN 0 RX	N/A	# 13	FFFFC8 _H	ICR01	0000B1 _H
CAN 0 TX/NS	N/A	# 14	FFFFC4 _H		
CAN 1 RX	N/A	# 15	FFFFC0 _H	ICR02	0000B2 _H
CAN 1 TX/NS	N/A	# 16	FFFFBC _H		
8/16 bit PPG 0/1	N/A	# 17	FFFFB8 _H	ICR03	0000B3 _H
8/16 bit PPG 2/3	N/A	# 18	FFFFB4 _H		
8/16 bit PPG 4/5	N/A	# 19	FFFFB0 _H	ICR04	0000B4 _H
8/16 bit PPG 6/7	N/A	# 20	FFFFAC _H		
8/16 bit PPG 8/9	N/A	# 21	FFFFA8 _H	ICR05	0000B5 _H
8/16 bit PPG A/B	N/A	# 22	FFFFA4 _H		
16-bit Reload Timer 0	*1	# 23	FFFFA0 _H	ICR06	0000B6 _H
16-bit Reload Timer 1	*1	# 24	FFFF9C _H		
Input Capture 0/1	*1	# 25	FFFF98 _H	ICR07	0000B7 _H
Output compare 0/1	*1	# 26	FFFF94 _H		
Input Capture 2/3	*1	# 27	FFFF90 _H	ICR08	0000B8 _H
Output Compare 2/3	*1	# 28	FFFF8C _H		
Input Capture 4/5	*1	# 29	FFFF88 _H	ICR09	0000B9 _H
Output Compare 4/5	*1	# 30	FFFF84 _H		
8/10 bit A/D Converter	*1	# 31	FFFF80 _H	ICR10	0000BA _H
16-bit Free-run Timer/Watch Timer	N/A	# 32	FFFF7C _H		
Serial I/O	*1	# 33	FFFF78 _H	ICR11	0000BB _H
Sound Generator	N/A	# 34	FFFF74 _H		
UART 0 RX	*2	# 35	FFFF70 _H	ICR12	0000BC _H
UART 0 TX	*1	# 36	FFFF6C _H		
UART 1 RX	*2	# 37	FFFF68 _H	ICR13	0000BD _H
UART 1 TX	*1	# 38	FFFF64 _H		
UART 2 RX	*2	# 39	FFFF60 _H	ICR14	0000BE _H
UART 2 TX	*1	# 40	FFFF5C _H		
Flash Memory	N/A	# 41	FFFF58 _H	ICR15	0000BF _H
Delayed interrupt	N/A	# 42	FFFF54 _H		

*1 : The interrupt request flag is cleared by the EI²OS interrupt clear signal.

*2 : The interrupt request flag is cleared by the EI²OS interrupt clear signal. A stop request is available.

N/A : The interrupt request flag is not cleared by the EI²OS interrupt clear signal.

Notes : • For a peripheral module with two interrupt for a single interrupt number, both interrupt request flags are cleared by the EI²OS interrupt clear signal.

- At the end of EI²OS, the EI²OS clear signal will be asserted for all the interrupt flags assigned to the same interrupt number. If one interrupt flag starts the EI²OS and in the meantime another interrupt flag is set by a hardware event, the later event is lost because the flag is cleared by the EI²OS clear signal caused by the first event. So it is recommended not to use the EI²OS for this interrupt number.

- If EI²OS is enabled, EI²OS is initiated when one of the two interrupt signals in the same interrupt control register (ICR) is asserted. This means that different interrupt sources share the same EI²OS Descriptor which should be unique for each interrupt source. For this reason, when one interrupt source uses the EI²OS, the other interrupt should be disabled.

MB90590G Series

■ ELECTRICAL CHARACTERISTICS

1. Absolute Maximum Ratings

($V_{SS} = AV_{SS} = 0.0\text{ V}$)

Parameter	Symbol	Rating		Unit	Remarks
		Min	Max		
Power supply voltage	V_{CC}	$V_{SS} - 0.3$	$V_{SS} + 6.0$	V	
	AV_{CC}	$V_{SS} - 0.3$	$V_{SS} + 6.0$	V	$V_{CC} = AV_{CC}$ *1
	AVRH, AVRL	$V_{SS} - 0.3$	$V_{SS} + 6.0$	V	$AV_{CC} \geq AVRH/L$, $AVRH \geq AVRL$ *1
	DV_{CC}	$V_{SS} - 0.3$	$V_{SS} + 6.0$	V	$V_{CC} \geq DV_{CC}$
Input voltage	V_I	$V_{SS} - 0.3$	$V_{SS} + 6.0$	V	*2
Output voltage	V_O	$V_{SS} - 0.3$	$V_{SS} + 6.0$	V	*2
Max clamp current	I_{CLAMP}	-2.0	+2.0	mA	*6
Total Max clamp current	$\sum I_{CLAMP} $	—	20	mA	*6
"L" level Max output current	I_{OL1}	—	15	mA	Normal output *3
"L" level avg. output current	I_{OLAV1}	—	4	mA	Normal output, average value *4
"L" level Max output current	I_{OL2}	—	40	mA	High current output *3
"L" level avg. output current	I_{OLAV2}	—	30	mA	High current output, average value *4
"L" level Max overall output current	$\sum I_{OL1}$	—	100	mA	Total normal output
"L" level Max overall output current	$\sum I_{OL2}$	—	330	mA	Total high current output
"L" level avg. overall output current	$\sum I_{OLAV1}$	—	50	mA	Total normal output, average value *5
"L" level avg. overall output current	$\sum I_{OLAV2}$	—	250	mA	Total high current output, average value *5
"H" level Max output current	I_{OH1}	—	-15	mA	Normal output *3
"H" level avg. output current	I_{OHAV1}	—	-4	mA	Normal output, average value *4
"H" level Max output current	I_{OH2}	—	-40	mA	High current output *3
"H" level avg. output current	I_{OHAV2}	—	-30	mA	High current output, average value *4
"H" level Max overall output current	$\sum I_{OH1}$	—	-100	mA	Total normal output
"H" level Max overall output current	$\sum I_{OH2}$	—	-330	mA	Total high current output
"H" level avg. overall output current	$\sum I_{OHAV1}$	—	-50	mA	Total normal output, average value *5
"H" level avg. overall output current	$\sum I_{OHAV2}$	—	-250	mA	Total high current output, average value *5
Power consumption	P_D	—	500	mW	MB90F594G, MB90F591G
		—	400	mW	MB90594G, MB90591G
Operating temperature	T_A	-40	+85	°C	
Storage temperature	T_{STG}	-55	+150	°C	

*1 : AV_{CC} , AVRH, AVRL and DV_{CC} shall not exceed V_{CC} . AVRH and AVRL shall not exceed AV_{CC} . Also, AVRL shall not exceed AVRH.

*2 : V_I and V_O should not exceed $V_{CC} + 0.3\text{V}$. V_I should not exceed the specified ratings. However if the maximum current to/from an input is limited by some means with external components, the I_{CLAMP} rating supersedes the V_I rating.

*3 : The maximum output current is a peak value for a corresponding pin.

*4 : Average output current is an average current value observed for a 100 ms period for a corresponding pin.

*5 : Total average current is an average current value observed for a 100 ms period for all corresponding pins.

(Continued)

(Continued)

- *6 : • Applicable to pins : P00 to P07, P10 to P17, P20 to P27, P30 to P37, P40 to P47, P50 to P57, P60 to P67, P70 to P77, P80 to P87, P90 to P95
- Use within recommended operating conditions.
- Use at DC voltage (current)
- The +B signal should always be applied with a limiting resistance placed between the +B signal and the microcontroller.
- The value of the limiting resistance should be set so that when the +B signal is applied the input current to the microcontroller pins does not exceed rated values, either instantaneously or for prolonged periods.
- Note that when the microcontroller drive current is low, such as in the power saving modes, the +B input potential may pass through the protective diode and increase the potential at the V_{CC} pin, and this may affect other devices.
- Note that if a +B signal is input when the microcontroller power supply is off (not fixed at 0 V) , the power supply is provided from the pins, so that incomplete operation may result.
- Note that if the +B input is applied during power-on, the power supply is provided from the pins and the resulting supply voltage may not be sufficient to operate the power-on reset.
- Care must be taken not to leave the +B input pin open.
- Note that analog system input/output pins other than the A/D input pins (LCD drive pins, comparator input pins, etc.) cannot accept +B signal input.
- Sample recommended circuits

• Input/Output equivalent circuits

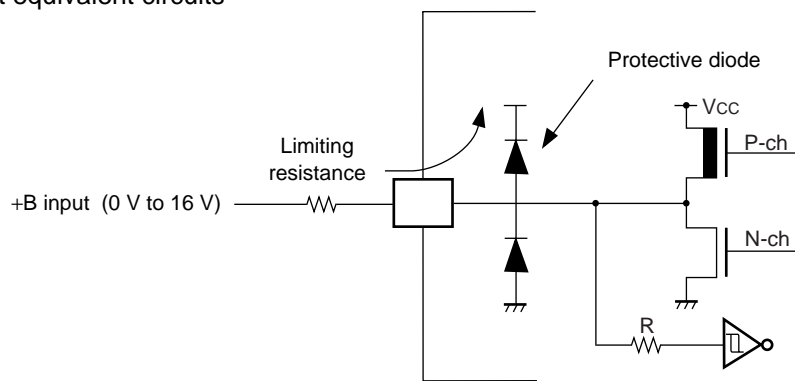

Note : Average output current = operating current × operating efficiency

WARNING: Semiconductor devices can be permanently damaged by application of stress (voltage, current, temperature, etc.) in excess of absolute maximum ratings. Do not exceed these ratings.

MB90590G Series

2. Recommended Conditions

($V_{SS} = AV_{SS} = 0.0\text{ V}$)

Parameter	Symbol	Value			Unit	Remarks	
		Min	Typ	Max			
Power supply voltage	V_{CC} AV_{CC}	4.5	5.0	5.5	V	Under normal operation	MB90V590G MB90F594G MB90594G
		3.0	—	5.5	V	Maintains RAM data in stop mode	
		4.75	5.0	5.25	V	Under normal operation	MB90F591G MB90591G
		3.0	—	5.25	V	Maintains RAM data in stop mode	
Smooth capacitor	C_S	0.022	0.1	1.0	μF	*	
Operating temperature	T_A	-40	—	+85	$^{\circ}\text{C}$		

* : Use a ceramic capacitor or a capacitor with equivalent frequency characteristics. The smoothing capacitor to be connected to the V_{CC} pin must have a capacitance value higher than C_S .

WARNING: The recommended operating conditions are required in order to ensure the normal operation of the semiconductor device. All of the device's electrical characteristics are warranted when the device is operated within these ranges.

Always use semiconductor devices within their recommended operating condition ranges.

Operation outside these ranges may adversely affect reliability and could result in device failure.

No warranty is made with respect to uses, operating conditions, or combinations not represented on the data sheet. Users considering application outside the listed conditions are advised to contact their representatives beforehand.

• C Pin Connection Diagram

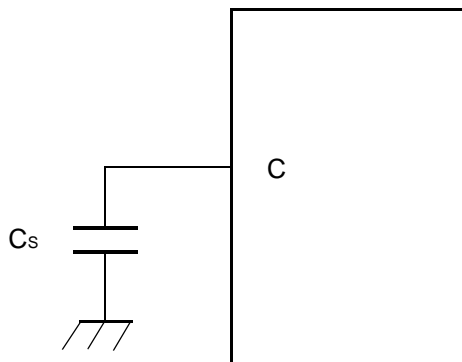

3. DC Characteristics

(MB90V590G, MB90F594G, MB90594G : $V_{CC} = 5.0 V \pm 10\%$, $V_{SS} = AV_{SS} = 0.0 V$, $T_A = -40\text{ }^\circ\text{C}$ to $+85\text{ }^\circ\text{C}$)
 (MB90F591G, MB90591G : $V_{CC} = 5.0 V \pm 5\%$, $V_{SS} = AV_{SS} = 0.0 V$, $T_A = -40\text{ }^\circ\text{C}$ to $+85\text{ }^\circ\text{C}$)

Parameter	Symbol	Pin name	Condition	Value			Unit	Remarks
				Min	Typ	Max		
Input H voltage	V_{IHS}	CMOS hysteresis input	—	$0.8 V_{CC}$	—	$V_{CC} + 0.3$	V	
	V_{IHM}	MD input	—	$V_{CC} - 0.3$	—	$V_{CC} + 0.3$	V	
Input L voltage	V_{ILS}	CMOS hysteresis input	—	$V_{SS} - 0.3$	—	$0.5V_{CC}$	V	
	V_{ILM}	MD input	—	$V_{SS} - 0.3$	—	$V_{SS} + 0.3$	V	
	V_{ILR}	\overline{RST} , \overline{HST}	—	$V_{SS} - 0.3$	—	$0.2V_{CC}$	V	
Output H voltage	V_{OH1}	Normal output	$V_{CC} = 4.5 V$, $I_{OH1} = -4.0\text{ mA}$	$V_{CC} - 0.5$	—	—	V	
	V_{OH2}	High current output	$V_{CC} = 4.5 V$, $I_{OH2} = -30.0\text{ mA}$	$V_{CC} - 0.5$	—	—	V	
Output L voltage	V_{OL1}	Normal output	$V_{CC} = 4.5 V$, $I_{OL1} = 4.0\text{ mA}$	—	—	0.4	V	
	V_{OL2}	High current output	$V_{CC} = 4.5 V$, $I_{OL2} = 30.0\text{ mA}$	—	—	0.5	V	
Input leak current	I_{IL}	—	$V_{CC} = 5.5 V$, $V_{SS} < V_I < V_{CC}$	-5	—	5	μA	
Analog input leak current	I_{IAL}	AN0 to AN7	$V_{CC} = 5.5 V$, $AV_{SS} < V_I < AV_{CC}$	-1	—	1	μA	
Power supply current *	I_{CC}	V_{CC}	$V_{CC} = 5.0 V \pm 10\%$, Internal frequency : 16 MHz, At normal operation.	—	37	60	mA	MB90594G
				—	50	80	mA	MB90F594G
				—	50	80	mA	MB90F591G
				—	45	60	mA	MB90591G
	I_{CCS}		$V_{CC} = 5.0 V \pm 10\%$, Internal frequency : 16 MHz, At Sleep mode.	—	13	20	mA	MB90594G
				—	15	23	mA	MB90F594G
				—	15	23	mA	MB90F591G
				—	15	23	mA	MB90591G
	I_{CTS}		$V_{CC} = 5.0 V \pm 10\%$, Internal frequency : 2 MHz, At Timer mode	—	0.3	0.6	mA	MB90594G
				—	0.35	0.6	mA	MB90F594G
				—	0.35	0.6	mA	MB90F591G
				—	0.35	0.6	mA	MB90591G
	I_{CCH}		$V_{CC} = 5.0 V \pm 10\%$, At Stop mode, $T_A = 25\text{ }^\circ\text{C}$	—	5	20	μA	MB90594G
				—	5	20	μA	MB90F594G
				—	5	20	μA	MB90F591G
				—	5	20	μA	MB90591G

* : The power supply current testing conditions are when using the external clock.

(Continued)

MB90590G Series

(Continued)

(MB90V590G, MB90F594G, MB90594G : $V_{CC} = 5.0 \text{ V} \pm 10 \%$, $V_{SS} = AV_{SS} = 0.0 \text{ V}$, $T_A = -40 \text{ }^\circ\text{C}$ to $+85 \text{ }^\circ\text{C}$)
 (MB90F591G, MB90591G : $V_{CC} = 5.0 \text{ V} \pm 5 \%$, $V_{SS} = AV_{SS} = 0.0 \text{ V}$, $T_A = -40 \text{ }^\circ\text{C}$ to $+85 \text{ }^\circ\text{C}$)

Parameter	Symbol	Pin name	Condition	Value			Unit	Remarks
				Min	Typ	Max		
Input capacity	C_{IN}	Other than C, AV _{CC} , AV _{SS} , AVRH, AVRL, V _{CC} , V _{SS} , DV _{CC} , DV _{SS} , P70 to P87	—	—	5	15	pF	
		P70 to P87	—	—	15	30	pF	
Pull-up resistance	R_{UP}	\overline{RST}	—	25	50	100	k Ω	
Pull-down resistance	R_{DOWN}	MD2	—	25	50	100	k Ω	

4. AC Characteristics

(1) Clock Timing

(MB90V590G, MB90F594G, MB90594G : $V_{CC} = 5.0 V \pm 10\%$, $V_{SS} = AV_{SS} = 0.0 V$, $T_A = -40\text{ }^\circ\text{C}$ to $+85\text{ }^\circ\text{C}$)
 (MB90F591G, MB90591G : $V_{CC} = 5.0 V \pm 5\%$, $V_{SS} = AV_{SS} = 0.0 V$, $T_A = -40\text{ }^\circ\text{C}$ to $+85\text{ }^\circ\text{C}$)

Parameter	Symbol	Pin name	Value			Unit	Remarks
			Min	Typ	Max		
Oscillation frequency	f_c	X0, X1	3	—	16	MHz	
Oscillation cycle time	t_{CYL}	X0, X1	62.5	—	333	ns	
Input clock pulse width	P_{WH}, P_{WL}	X0	10	—	—	ns	Duty ratio is about 30 to 70%.
Input clock rise and fall time	t_{CR}, t_{CF}	X0	—	—	5	ns	When using external clock
Machine clock frequency	f_{CP}	—	1.5	—	16	MHz	
Machine clock cycle time	t_{CP}	—	62.5	—	666	ns	
Flash read cycle time	t_{CYCFL}	—	—	$2 t_{CP}$	—	ns	When Flash is accessed by CPU

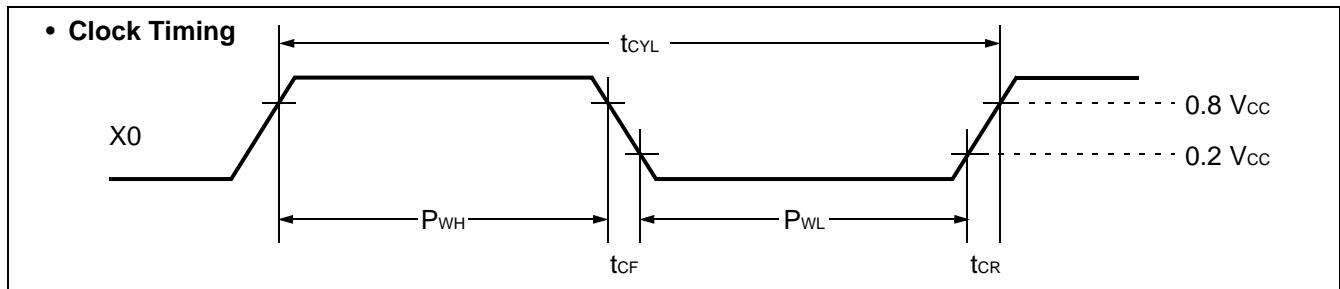

Example of Oscillation circuit

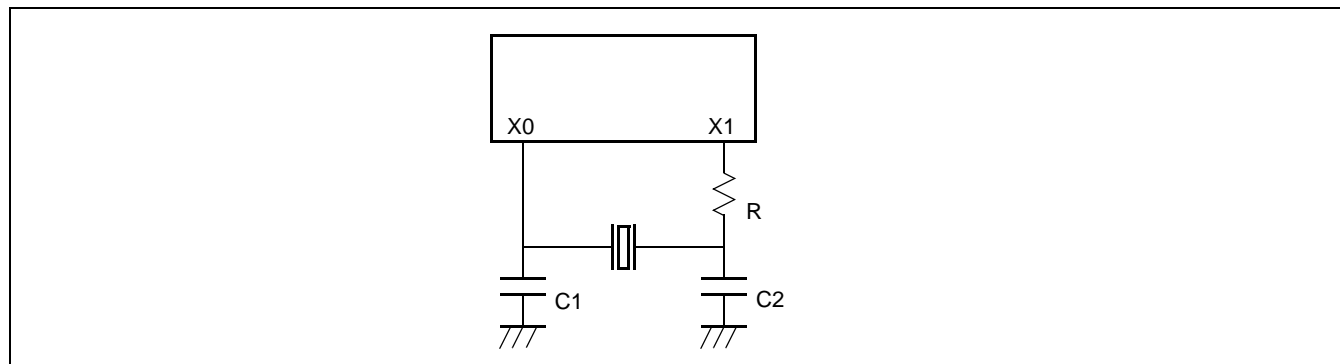

MB90590G Series

• Guaranteed operation range

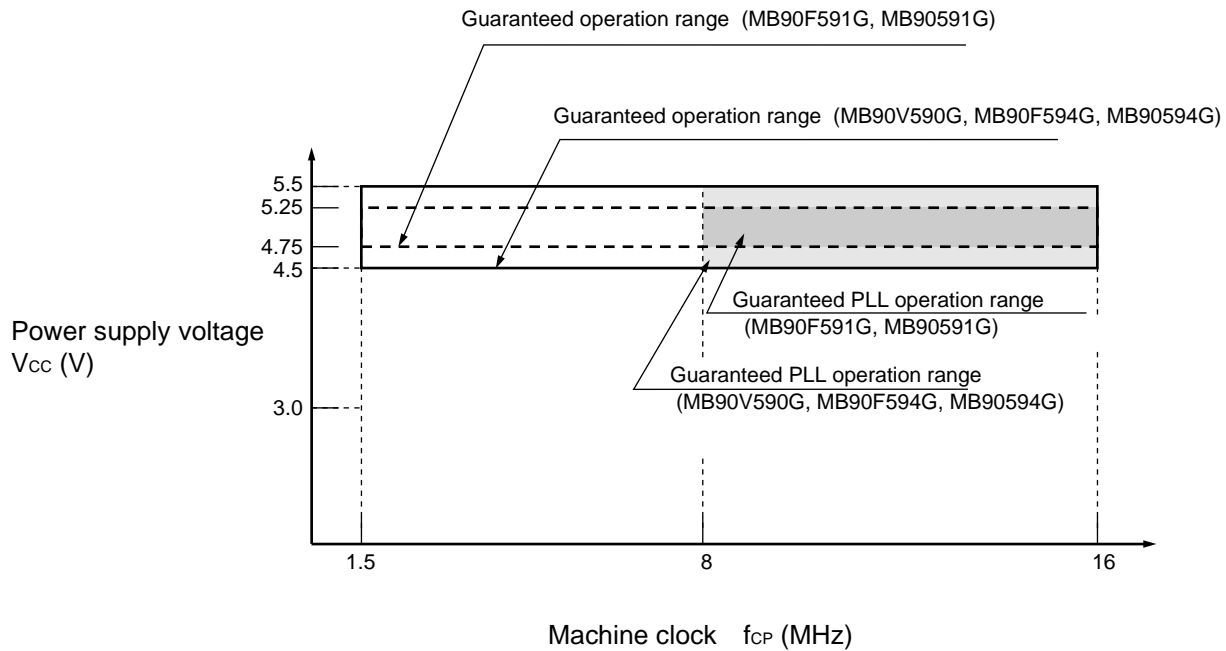

• Oscillation clock frequency and machine clock frequency

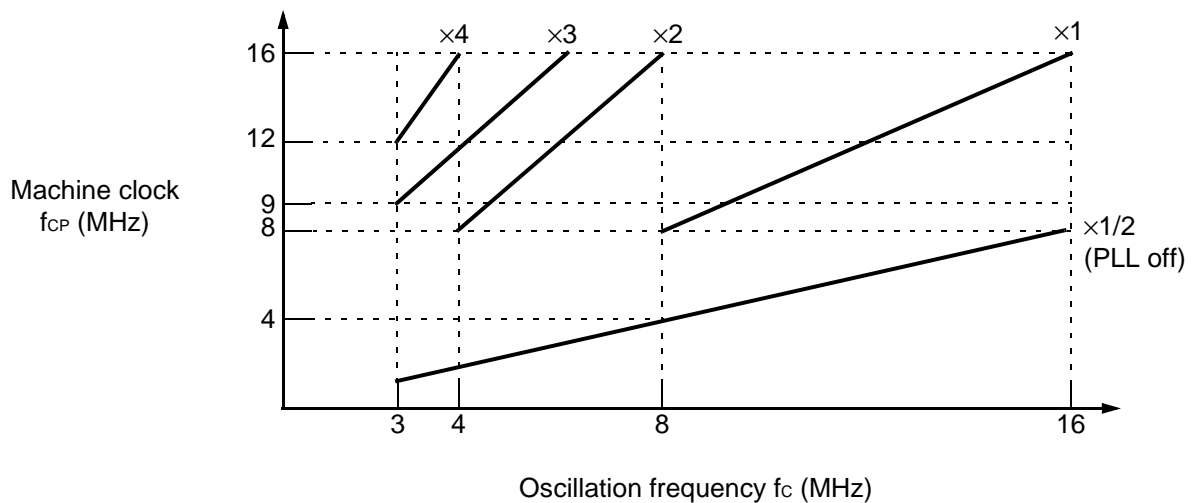

(2) Reset and Hardware Standby Input Timing

(MB90V590G, MB90F594G, MB90594G : $V_{CC} = 5.0 V \pm 10\%$, $V_{SS} = AV_{SS} = 0.0 V$, $T_A = -40\text{ }^\circ\text{C}$ to $+85\text{ }^\circ\text{C}$)
 (MB90F591G, MB90591G : $V_{CC} = 5.0 V \pm 5\%$, $V_{SS} = AV_{SS} = 0.0 V$, $T_A = -40\text{ }^\circ\text{C}$ to $+85\text{ }^\circ\text{C}$)

Parameter	Symbol	Pin name	Value		Unit	Remarks
			Min	Max		
Reset input time	t_{RSTL}	\overline{RST}	$16 t_{CP}^{*1}$	—	ns	Under normal operation
			Oscillation time of oscillator ^{*2} + $16 t_{CP}^{*1}$	—	ms	In stop mode
Hardware standby input time	t_{HSTL}	\overline{HST}	$16 t_{CP}^{*1}$	—	ns	Under normal operation

*1 : “ t_{cp} ” represents one cycle time of the machine clock.

No reset can fully initialize the Flash Memory if it is performing the automatic algorithm.

*2 : Oscillation time of oscillator is time that the amplitude reached the 90%.

In the crystal oscillator, the oscillation time is between several ms to tens of ms. In ceramic oscillator, the oscillation time is between hundreds of μs to several ms. In the external clock, the oscillation time is 0 ms.

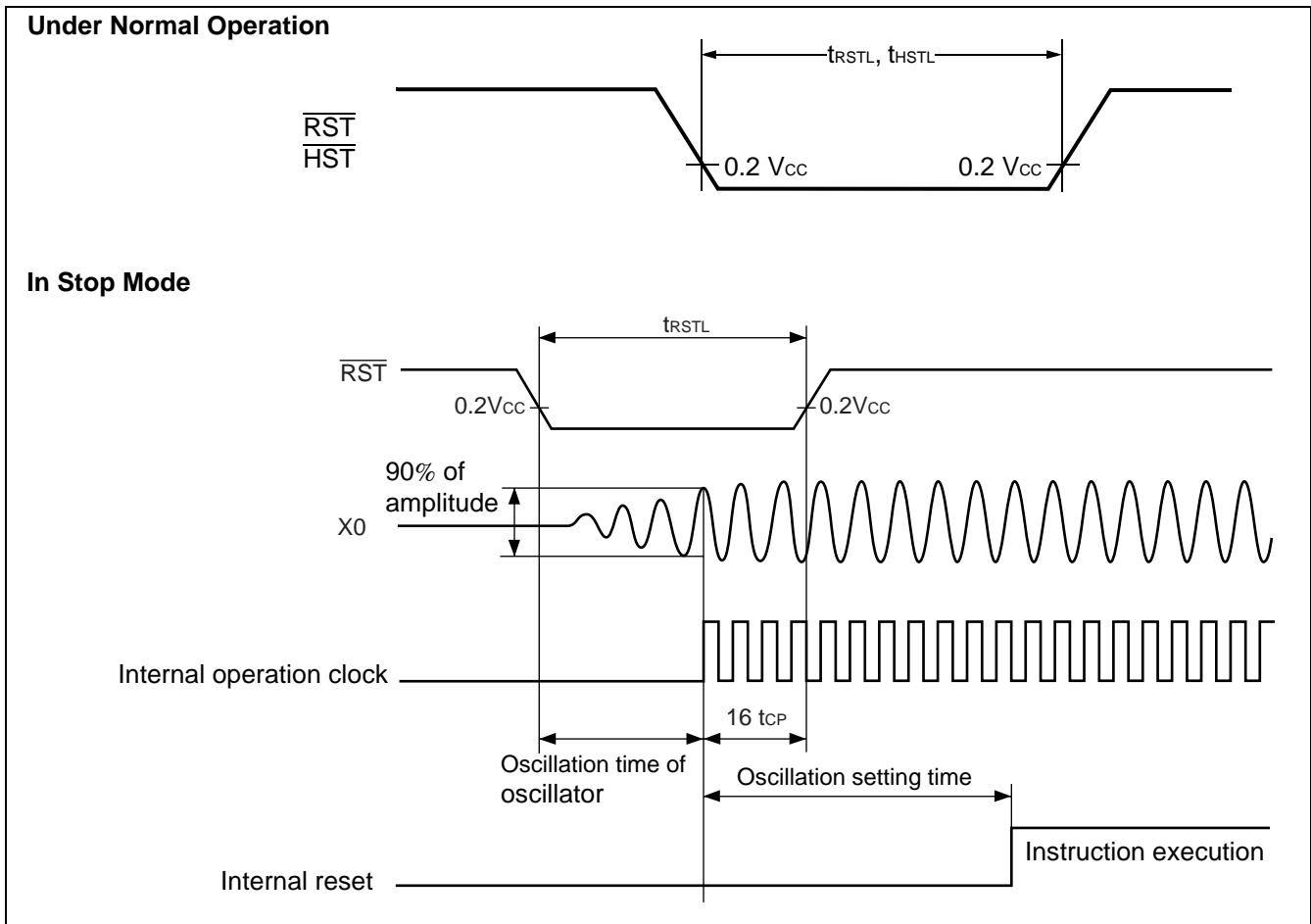

MB90590G Series

(3) Power On Reset

(MB90V590G, MB90F594G, MB90594G : $V_{CC} = 5.0 \text{ V} \pm 10 \%$, $V_{SS} = AV_{SS} = 0.0 \text{ V}$, $T_A = -40 \text{ }^\circ\text{C}$ to $+85 \text{ }^\circ\text{C}$)

(MB90F591G, MB90591G : $V_{CC} = 5.0 \text{ V} \pm 5 \%$, $V_{SS} = AV_{SS} = 0.0 \text{ V}$, $T_A = -40 \text{ }^\circ\text{C}$ to $+85 \text{ }^\circ\text{C}$)

Parameter	Symbol	Pin name	Condition	Value		Unit	Remarks
				Min	Max		
Power on rise time	t_r	V_{CC}	—	0.05	30	ms	
Power off time	t_{OFF}	V_{CC}		50	—	ms	Due to repetitive operation

Notes : • V_{CC} must be kept lower than 0.2 V before power-on.

• The above values are used for creating a power-on reset.

• Some registers in the device are initialized only upon a power-on reset. To initialize these register, turn on the power supply using the above values.

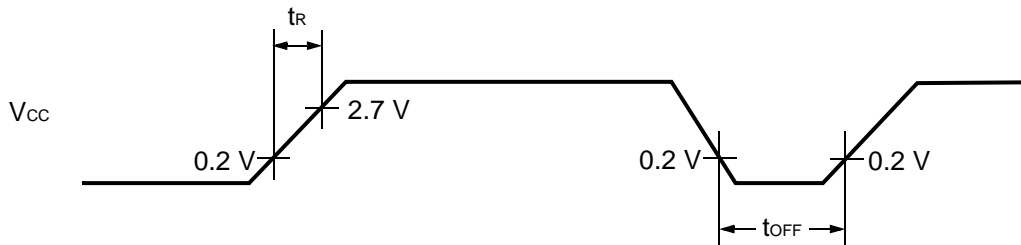

Sudden changes in the power supply voltage may cause a power-on reset.

To change the power supply voltage while the device is in operation, it is recommended to raise the voltage smoothly to suppress fluctuations as shown below.

In this case, change the supply voltage with the PLL clock not used. If the voltage drop is 1 V or fewer per second, however, you can use the PLL clock.

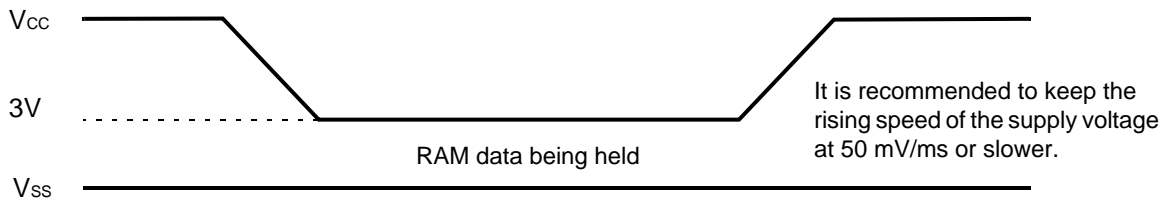

(4) UART0/1/2, Serial I/O Timing

(MB90V590G, MB90F594G, MB90594G : $V_{CC} = 5.0 V \pm 10\%$, $V_{SS} = AV_{SS} = 0.0 V$, $T_A = -40\text{ }^\circ\text{C}$ to $+85\text{ }^\circ\text{C}$)

(MB90F591G, MB90591G : $V_{CC} = 5.0 V \pm 5\%$, $V_{SS} = AV_{SS} = 0.0 V$, $T_A = -40\text{ }^\circ\text{C}$ to $+85\text{ }^\circ\text{C}$)

Parameter	Symbol	Pin name	Condition	Value		Unit	Remarks
				Min	Max		
Serial clock cycle time	t_{SCYC}	SCK0 to SCK3	Internal clock operation output pins are $C_L = 80\text{ pF} + 1\text{ TTL}$.	$8 t_{CP}^*$	—	ns	
SCK $\downarrow \Rightarrow$ SOT delay time	t_{SLOV}	SCK0 to SCK3, SOT0 to SOT3		-80	80	ns	
Valid SIN \Rightarrow SCK \uparrow	t_{VSH}	SCK0 to SCK3, SIN0 to SIN3		100	—	ns	
SCK $\uparrow \Rightarrow$ Valid SIN hold time	t_{SHIX}	SCK0 to SCK3, SIN0 to SIN3		60	—	ns	
Serial clock "H" pulse width	t_{SHSL}	SCK0 to SCK3	External clock operation output pins are $C_L = 80\text{ pF} + 1\text{ TTL}$.	$4 t_{CP}$	—	ns	
Serial clock "L" pulse width	t_{LSLH}	SCK0 to SCK3		$4 t_{CP}$	—	ns	
SCK $\downarrow \Rightarrow$ SOT delay time	t_{SLOV}	SCK0 to SCK3, SOT0 to SOT3		—	150	ns	
Valid SIN \Rightarrow SCK \uparrow	t_{VSH}	SCK0 to SCK3, SIN0 to SIN3		60	—	ns	
SCK $\uparrow \Rightarrow$ Valid SIN hold time	t_{SHIX}	SCK0 to SCK3, SIN0 to SIN3		60	—	ns	

* : t_{CP} is the machine cycle (Unit : ns)

Notes : • AC characteristic in CLK synchronized mode.

• C_L is load capacity value of pins when testing.

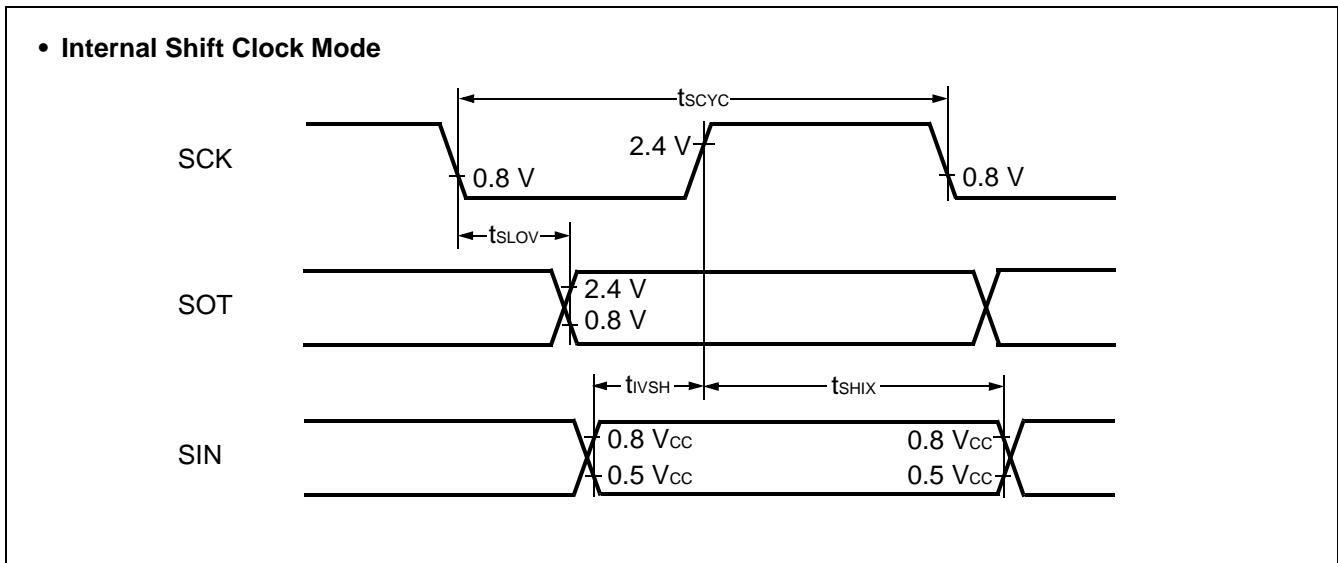

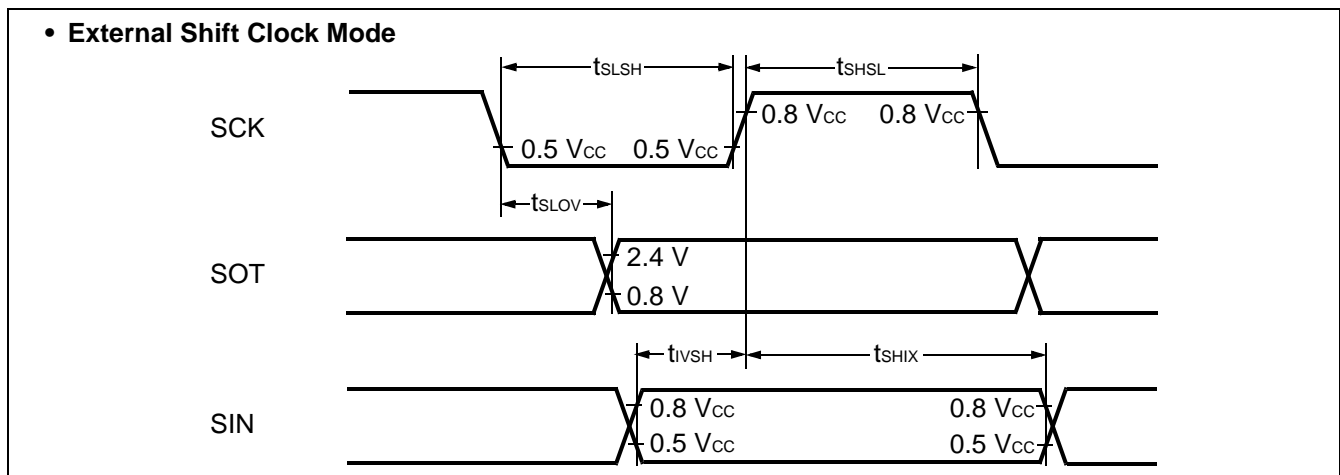

(5) Timer Input Timing

(MB90V590G, MB90F594G, MB90594G : $V_{CC} = 5.0 V \pm 10\%$, $V_{SS} = AV_{SS} = 0.0 V$, $T_A = -40^\circ C$ to $+85^\circ C$)
 (MB90F591G, MB90591G : $V_{CC} = 5.0 V \pm 5\%$, $V_{SS} = AV_{SS} = 0.0 V$, $T_A = -40^\circ C$ to $+85^\circ C$)

Parameter	Symbol	Pin name	Condition	Value		Unit	Remarks
				Min	Max		
Input pulse width	t_{TIWH}	TIN0	—	$4 t_{CP}$	—	ns	Under normal operation
	t_{TIWL}	IN0 to IN5		1	—	μs	In stop mode

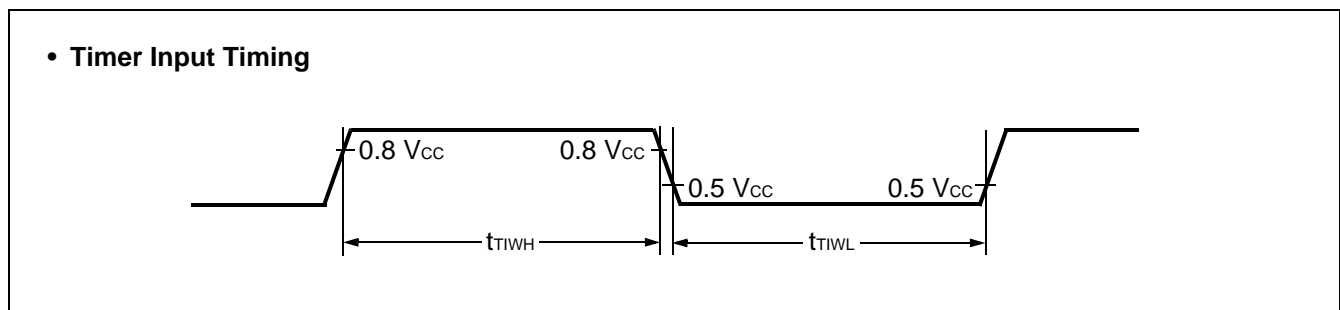

(6) Trigger Input Timing

(MB90V590G, MB90F594G, MB90594G : $V_{CC} = 5.0 V \pm 10\%$, $V_{SS} = AV_{SS} = 0.0 V$, $T_A = -40\text{ }^\circ\text{C}$ to $+85\text{ }^\circ\text{C}$)
 (MB90F591G, MB90591G : $V_{CC} = 5.0 V \pm 5\%$, $V_{SS} = AV_{SS} = 0.0 V$, $T_A = -40\text{ }^\circ\text{C}$ to $+85\text{ }^\circ\text{C}$)

Parameter	Symbol	Pin name	Condition	Value		Unit	Remarks
				Min	Max		
Input pulse width	t_{TRGH} t_{TRGL}	INT0 to INT7, ADTG	—	5 t_{CP}	—	ns	

• Trigger Input Timing

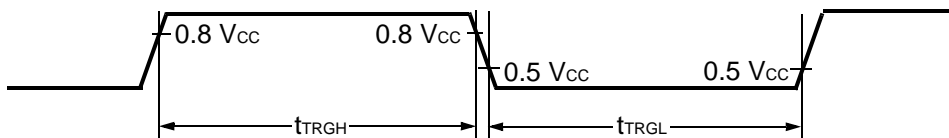

(7) Slew Rate High Current Outputs (MB90F591G, MB90591G, MB90594G and MB90F594G only)

(MB90F594G, MB90594G : $V_{CC} = 5.0 V \pm 10\%$, $V_{SS} = AV_{SS} = 0.0 V$, $T_A = -40\text{ }^\circ\text{C}$ to $+85\text{ }^\circ\text{C}$)
 (MB90F591G, MB90591G : $V_{CC} = 5.0 V \pm 5\%$, $V_{SS} = AV_{SS} = 0.0 V$, $T_A = -40\text{ }^\circ\text{C}$ to $+85\text{ }^\circ\text{C}$)

Parameter	Symbol	Pin name	Condition	Value		Unit	Remarks
				Min	Max		
Output Rise/Fall time	t_{R2} t_{F2}	Port P70 to P77, Port P80 to P87	—	15	40	ns	

• Slew Rate Output Timing

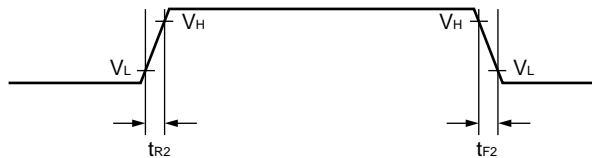

$$V_H = V_{OL2} + 0.1 \times (V_{OH2} - V_{OL2})$$

$$V_L = V_{OL2} + 0.9 \times (V_{OH2} - V_{OL2})$$

MB90590G Series

5. A/D Converter

(MB90V590G, MB90F594G, MB90594G :

$V_{CC} = AV_{CC} = 5.0 V \pm 10\%$, $V_{SS} = AV_{SS} = 0.0 V$, $3.0 V \leq AVR+ - AVR-$, $T_A = -40\text{ }^\circ\text{C to } +85\text{ }^\circ\text{C}$)

(MB90F591G, MB90591G :

$V_{CC} = AV_{CC} = 5.0 V \pm 5\%$, $V_{SS} = AV_{SS} = 0.0 V$, $3.0 V \leq AVR+ - AVR-$, $T_A = -40\text{ }^\circ\text{C to } +85\text{ }^\circ\text{C}$)

Parameter	Symbol	Pin name	Value			Unit	Remarks
			Min	Typ	Max		
Resolution	—	—	—	—	10	bit	
Conversion error	—	—	—	—	± 5.0	LSB	
Nonlinearity error	—	—	—	—	± 2.5	LSB	
Differential linearity error	—	—	—	—	± 1.9	LSB	
Zero transition voltage	V_{OT}	AN0 to AN7	AVRL - 3.5 LSB	AVRL + 0.5 LSB	AVRL + 4.5 LSB	V	
Full scale transition voltage	V_{FST}	AN0 to AN7	AVRH - 6.5 LSB	AVRH - 1.5 LSB	AVRH + 1.5 LSB	V	
Compare time	—	—	$352t_{CP}$	—	—	ns	Internal frequency : 16 MHz
Sampling time	—	—	$64t_{CP}$	—	—	ns	Internal frequency : 16 MHz
Analog port input current	I_{AIN}	AN0 to AN7	-1	—	+1	μA	
Analog input voltage range	V_{AIN}	AN0 to AN7	AVRL	—	AVRH	V	
Reference voltage range	—	AVRH	AVRL + 2.7	—	AV_{CC}	V	
	—	AVRL	0	—	$AVRH - 2.7$	V	
Power supply current	I_A	AV_{CC}	—	5	—	mA	
	I_{AH}	AV_{CC}	—	—	5	μA	*
Reference voltage current	I_R	AVRH	—	400	600	μA	MB90V590G MB90F594G MB90F591G
			—	140	600	μA	MB90594G MB90591G
	I_{RH}	AVRH	—	—	5	μA	*
Offset between input channels	—	AN0 to AN7	—	—	4	LSB	

* : When not operating A/D converter, this is the current ($V_{CC} = AV_{CC} = AVRH = 5.0 V$) when the CPU is stopped.

6. A/D Converter Glossary

Resolution : Analog changes that are identifiable with the A/D converter

Linearity error : The deviation of the straight line connecting the zero transition point (“00 0000 0000” ↔ “00 0000 0001”) with the full-scale transition point (“11 1111 1110” ↔ “11 1111 1111”) from actual conversion characteristics

Differential linearity error : The deviation of input voltage needed to change the output code by 1 LSB from the theoretical value

Total error : The total error is defined as a difference between the actual value and the theoretical value, which includes zero-transition error/full-scale transition error and linearity error.

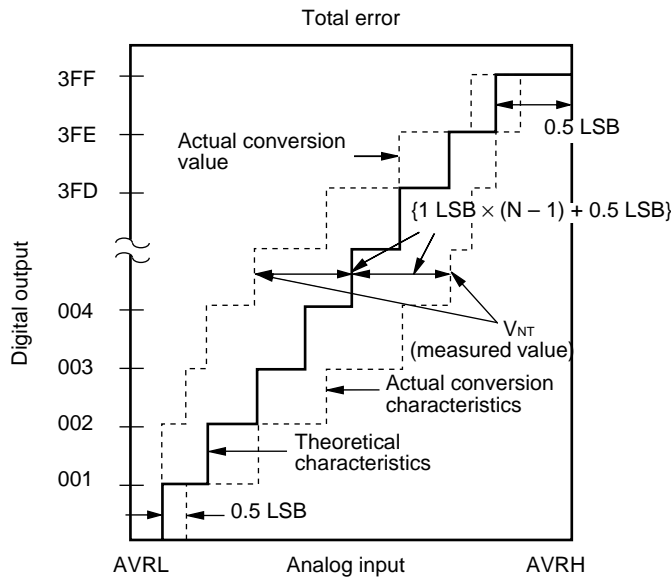

$$1 \text{ LSB} = (\text{Theoretical value}) \frac{\text{AVRH} - \text{AVRL}}{1024} \text{ [V]}$$

$$\text{Total error for digital output } N = \frac{V_{NT} - \{1 \text{ LSB} \times (N - 1) + 0.5 \text{ LSB}\}}{1 \text{ LSB}} \text{ [LSB]}$$

$$V_{0T} (\text{Theoretical value}) = \text{AVRL} + 0.5 \text{ LSB [V]}$$

V_{NT} : Voltage at a transition of digital output from $(N - 1)$ to N

$$V_{FST} (\text{Theoretical value}) = \text{AVRH} - 1.5 \text{ LSB [V]}$$

(Continued)

(Continued)

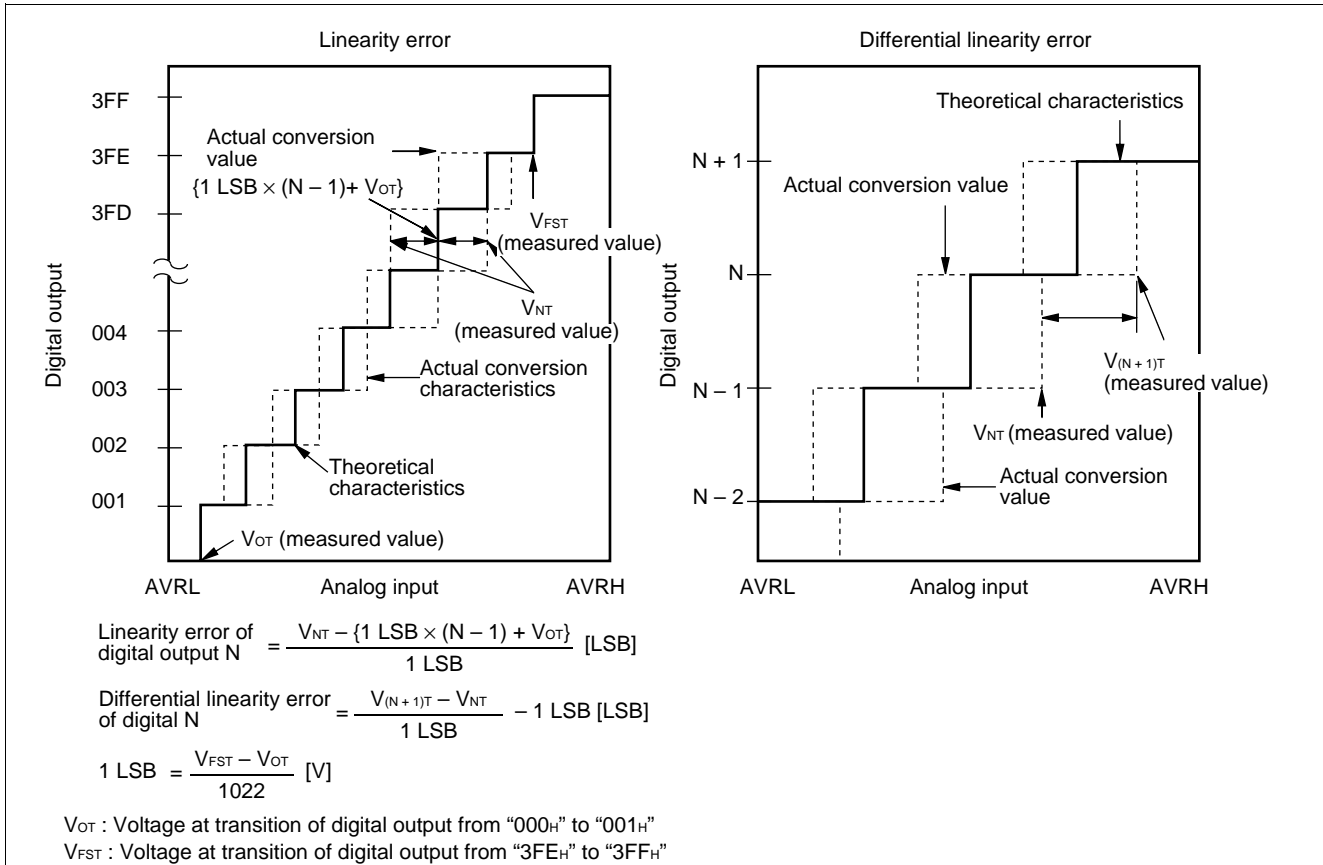

7. Notes on Using A/D Converter

Select the output impedance value for the external circuit of analog input according to the following conditions :

- Output impedance values of the external circuit of 15 kΩ or lower are recommended.
- When capacitors are connected to external pins, the capacitance of several thousand times the internal capacitor value is recommended to minimized the effect of voltage distribution between the external capacitor and internal capacitor.

When the output impedance of the external circuit is too high, the sampling period for analog voltages may not be sufficient (sampling period = 4.00 μs @ machine clock of 16 MHz).

• Equipment of analog input circuit model

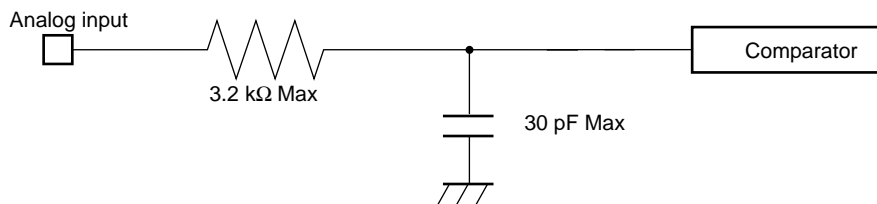

Note : Listed values must be considered as standards.

• Error

The smaller the | AVRH – AVRL |, the greater the error would become relatively.

8. Flash Memory

- Erase and Programming Performance

Parameter	Condition	Value			Unit	Remarks	
		Min	Typ	Max			
Sector erase time	T _A = + 25 °C V _{CC} = 5.0 V	—	1	15	s	Excludes 00H programming prior erasure	
Chip erase time		—	7	—	s	MB90F594G	Excludes 00H programming prior erasure
		—	12	—	s	MB90F591G	
Word (16-bit) programming time		—	16	3,600	ns	Excludes system-level overhead	
Erase/Program cycle	—	10,000	—	—	cycle		

EXAMPLE CHARACTERISTICS

• “H” Level Output Voltage

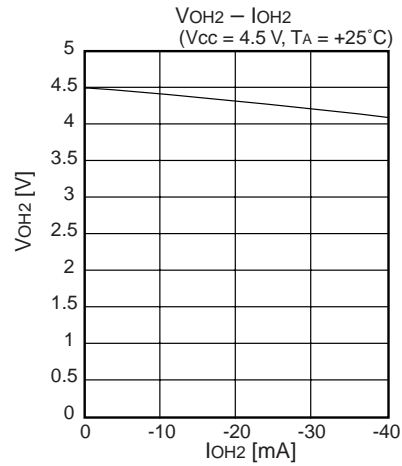
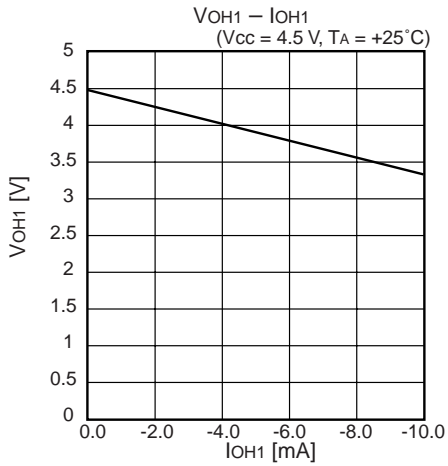

• “L” Level Output Voltage

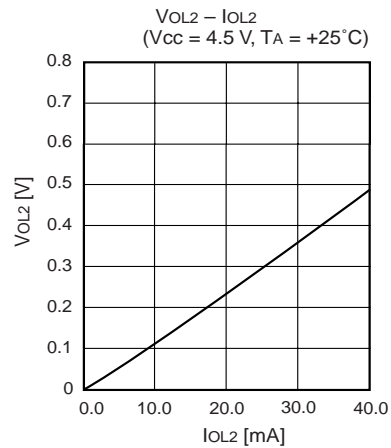
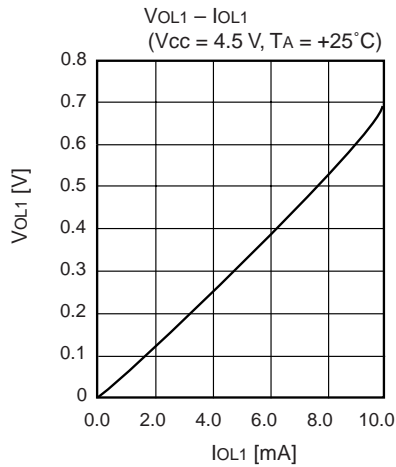

• “H” Level Input Voltage/“L” Level Input Voltage (Hysteresis Input)

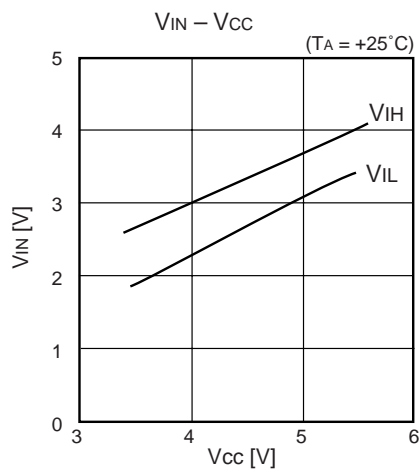

(Continued)

(Continued)

• Power Supply Voltage

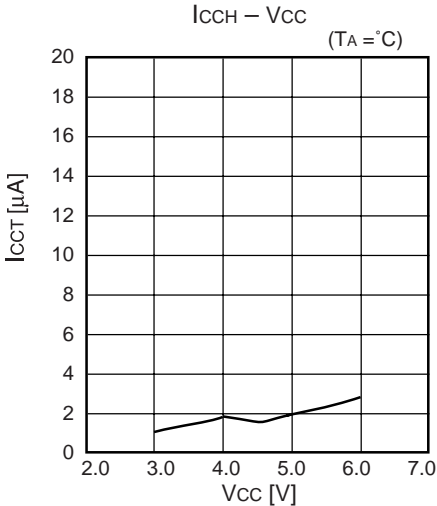
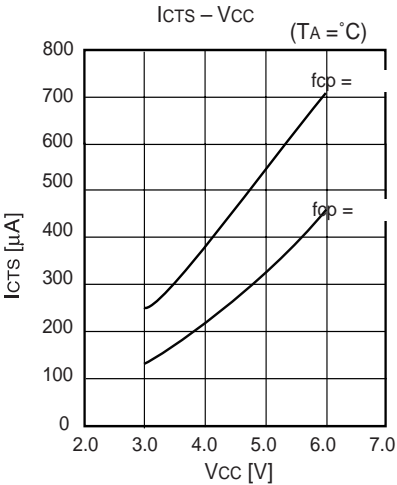
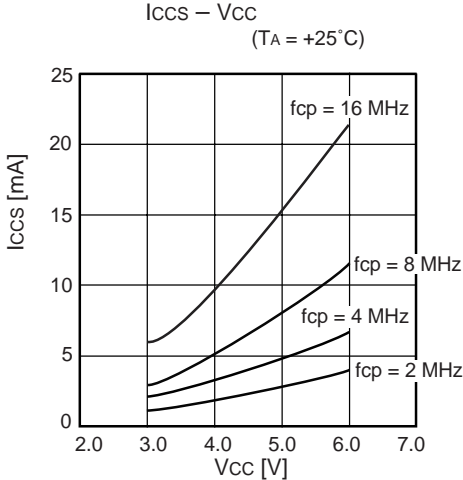
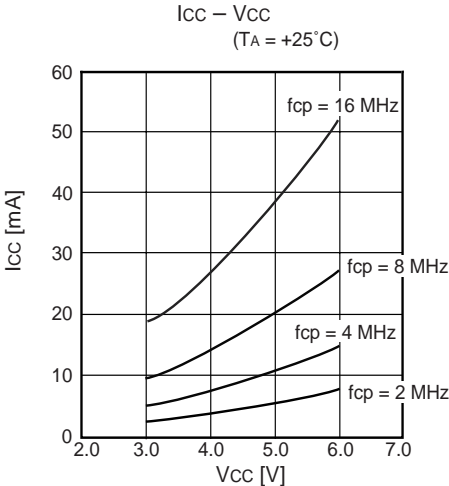

MB90590G Series

■ ORDERING INFORMATION

Part number	Package	Remarks
MB90594GPF MB90F594GPF MB90F591GPF MB90591GPF	100-pin Plastic QFP (FPT-100P-M06)	
MB90V590GCR	256-pin Ceramic PGA (PGA-256C-A01)	For evaluation

PACKAGE DIMENSION

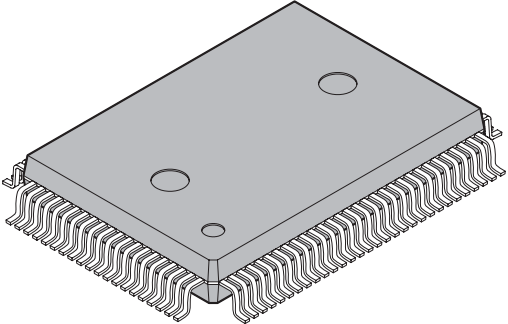
<p>100-pin plastic QFP</p>  <p>(FPT-100P-M06)</p>	Lead pitch	0.65 mm
	Package width × package length	14.00 × 20.00 mm
	Lead shape	Gullwing
	Sealing method	Plastic mold
	Mounting height	3.35 mm MAX
	Code (Reference)	P-QFP100-14×20-0.65

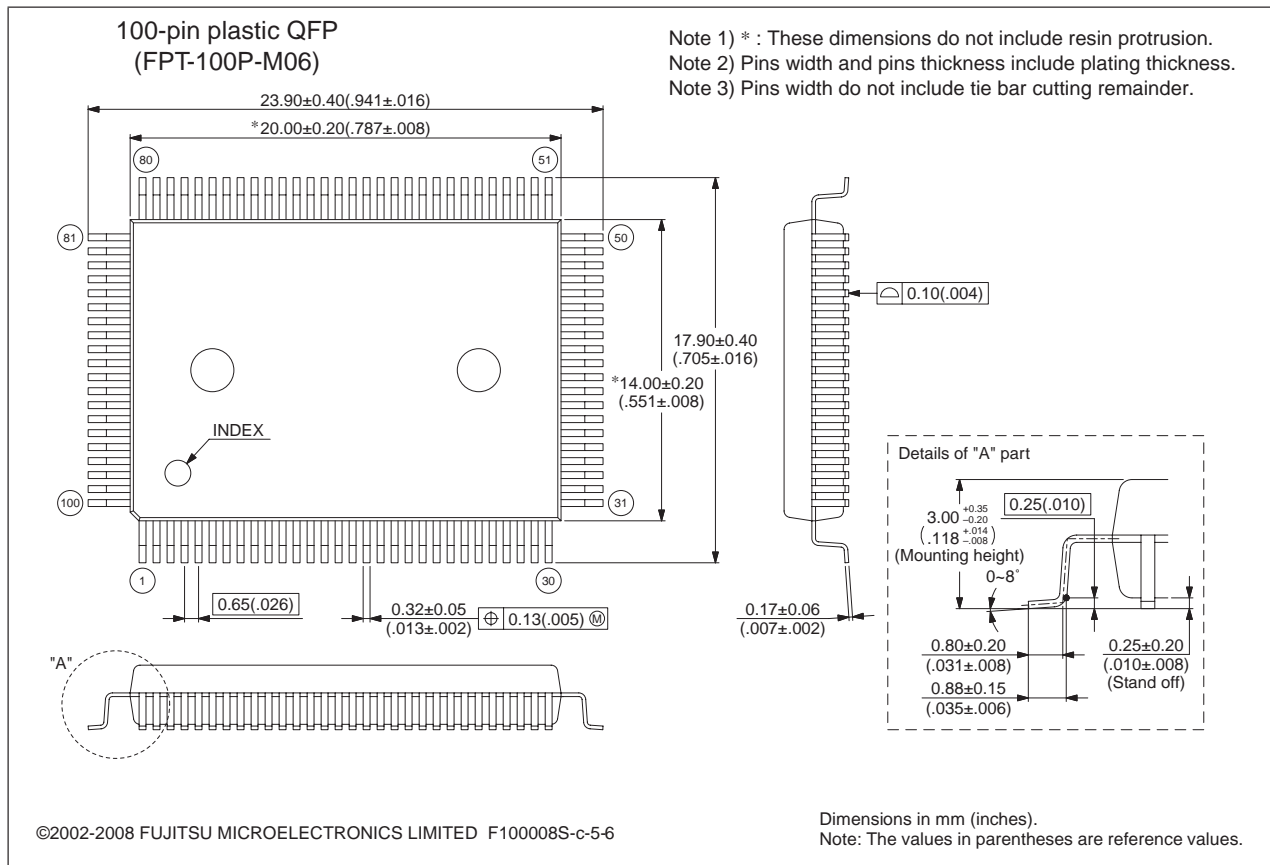

Please confirm the latest Package dimension by following URL.
<http://edevic.fujitsu.com/package/en-search/>

MB90590G Series

■ MAIN CHANGES IN THIS EDITION

Page	Section	Change Results
—	—	Deleted the part numbers. MB90591, MB90F591A, MB90594, MB90F594A, MB90V590A
—	—	Changed the series name. MB90590/590G series → MB90590G series
—	—	Changed the following name. I/O Timer → 16-bit Free-run Timer
—	—	Peripheral Resource name is changed. Clock Timer → Watch Timer
—	—	one of Standby mode name is changed. Clock mode → Watch mode
17	■ BLOCK DIAGRAM	Changed the number of channels of 16-bit output compare. 4 ch → 6 ch
35	■ INTERRUPT MAP	Changed the abbreviation of Extended Intelligent I/O Service. I ² OS → EI ² OS
48	■ ELECTRICAL CHARACTERISTICS 5. A/D Converter	Changed the items of “Zero transition voltage” and “Full scale transition voltage”. mV → V

The vertical lines marked in the left side of the page show the changes.

MEMO

MEMO

MEMO

MB90590G Series

FUJITSU MICROELECTRONICS LIMITED

Shinjuku Dai-Ichi Seimei Bldg., 7-1, Nishishinjuku 2-chome,
Shinjuku-ku, Tokyo 163-0722, Japan
Tel: +81-3-5322-3347 Fax: +81-3-5322-3387
<http://jp.fujitsu.com/fml/en/>

For further information please contact:

North and South America

FUJITSU MICROELECTRONICS AMERICA, INC.
1250 E. Arques Avenue, M/S 333
Sunnyvale, CA 94085-5401, U.S.A.
Tel: +1-408-737-5600 Fax: +1-408-737-5999
<http://www.fma.fujitsu.com/>

Asia Pacific

FUJITSU MICROELECTRONICS ASIA PTE. LTD.
151 Lorong Chuan,
#05-08 New Tech Park 556741 Singapore
Tel : +65-6281-0770 Fax : +65-6281-0220
<http://www.fmal.fujitsu.com/>

Europe

FUJITSU MICROELECTRONICS EUROPE GmbH
Pittlerstrasse 47, 63225 Langen, Germany
Tel: +49-6103-690-0 Fax: +49-6103-690-122
<http://emea.fujitsu.com/microelectronics/>

FUJITSU MICROELECTRONICS SHANGHAI CO., LTD.

Rm. 3102, Bund Center, No.222 Yan An Road (E),
Shanghai 200002, China
Tel : +86-21-6146-3688 Fax : +86-21-6335-1605
<http://cn.fujitsu.com/fmc/>

Korea

FUJITSU MICROELECTRONICS KOREA LTD.
206 Kosmo Tower Building, 1002 Daechi-Dong,
Gangnam-Gu, Seoul 135-280, Republic of Korea
Tel: +82-2-3484-7100 Fax: +82-2-3484-7111
<http://kr.fujitsu.com/fmk/>

FUJITSU MICROELECTRONICS PACIFIC ASIA LTD.

10/F., World Commerce Centre, 11 Canton Road,
Tsimshatsui, Kowloon, Hong Kong
Tel : +852-2377-0226 Fax : +852-2376-3269
<http://cn.fujitsu.com/fmc/en/>

Specifications are subject to change without notice. For further information please contact each office.

All Rights Reserved.

The contents of this document are subject to change without notice.

Customers are advised to consult with sales representatives before ordering.

The information, such as descriptions of function and application circuit examples, in this document are presented solely for the purpose of reference to show examples of operations and uses of FUJITSU MICROELECTRONICS device; FUJITSU MICROELECTRONICS does not warrant proper operation of the device with respect to use based on such information. When you develop equipment incorporating the device based on such information, you must assume any responsibility arising out of such use of the information.

FUJITSU MICROELECTRONICS assumes no liability for any damages whatsoever arising out of the use of the information.

Any information in this document, including descriptions of function and schematic diagrams, shall not be construed as license of the use or exercise of any intellectual property right, such as patent right or copyright, or any other right of FUJITSU MICROELECTRONICS or any third party or does FUJITSU MICROELECTRONICS warrant non-infringement of any third-party's intellectual property right or other right by using such information. FUJITSU MICROELECTRONICS assumes no liability for any infringement of the intellectual property rights or other rights of third parties which would result from the use of information contained herein.

The products described in this document are designed, developed and manufactured as contemplated for general use, including without limitation, ordinary industrial use, general office use, personal use, and household use, but are not designed, developed and manufactured as contemplated (1) for use accompanying fatal risks or dangers that, unless extremely high safety is secured, could have a serious effect to the public, and could lead directly to death, personal injury, severe physical damage or other loss (i.e., nuclear reaction control in nuclear facility, aircraft flight control, air traffic control, mass transport control, medical life support system, missile launch control in weapon system), or (2) for use requiring extremely high reliability (i.e., submersible repeater and artificial satellite).

Please note that FUJITSU MICROELECTRONICS will not be liable against you and/or any third party for any claims or damages arising in connection with above-mentioned uses of the products.

Any semiconductor devices have an inherent chance of failure. You must protect against injury, damage or loss from such failures by incorporating safety design measures into your facility and equipment such as redundancy, fire protection, and prevention of over-current levels and other abnormal operating conditions.

Exportation/release of any products described in this document may require necessary procedures in accordance with the regulations of the Foreign Exchange and Foreign Trade Control Law of Japan and/or US export control laws.

The company names and brand names herein are the trademarks or registered trademarks of their respective owners.

Edited: Business & Media Promotion Dept.