

# 8-bit Proprietary Microcontroller

CMOS

## F<sup>2</sup>MC-8L MB89470 Series

### MB89475/P475/PV470

#### ■ DESCRIPTION

The MB89470 series has been developed as a general-purpose version of the F<sup>2</sup>MC\*-8L family consisting of proprietary 8-bit, single-chip microcontrollers.

In addition to a compact instruction set, the microcontroller contains a variety of peripheral functions such as 21-bit time-base timer, watch prescaler, PWC timer, PWM timer, 8/16-bit timer/counter, external interrupt 1 (edge), external interrupt 2 (level), 10-bit A/D converter, UART/SIO, buzzer, watchdog timer reset.

The MB89470 series is designed suitable for home appliance as well as in a wide range of applications for consumer product.

\* : F<sup>2</sup>MC is the abbreviation of FUJITSU Flexible Microcontroller.

#### ■ FEATURES

- Package used  
QFP package, LQFP package and SH-DIP package for MB89P475, MB89475  
MQFP package for MB89PV470

(Continued)

For the information for microcontroller supports, see the following web site.

<http://edevice.fujitsu.com/micom/en-support/>

# MB89470 Series

(Continued)

- High-speed operating capability at low voltage
  - Minimum execution time : 0.32  $\mu$ s/12.5 MHz
  - F<sup>2</sup>MC-8L family CPU core
- Instruction set optimized for controllers
- Multiplication and division instructions
  - 16-bit arithmetic operations
  - Bit test and branch instructions
  - Bit manipulation instructions, etc.
- Six timers
    - PWC timer (also usable as an interval timer)
    - PWM timer
    - 8/16-bit timer/counter  $\times$  2
    - 21-bit timebase timer
    - Watch prescaler
  - Buzzer
    - 7 frequency types are selectable by software
  - External interrupts
    - Edge detection (Selectable edge) : 4 channels
    - Low-level interrupt (Wake-up function) : 5 channels
  - A/D converter (8 channels)
    - 10-bit successive approximation type
  - UART/SIO
    - Synchronous/asynchronous data transfer capable
  - Low-power consumption modes
    - Stop mode (Oscillation stops to minimize the current consumption.)
    - Sleep mode (The CPU stops to reduce the current consumption to approx. 1/3 of normal.)
    - Subclock mode (for dual clock product)
    - Watch mode (for dual clock product)
  - Watchdog timer reset
  - I/O ports : Max 39 channels

# MB89470 Series

## ■ PRODUCT LINEUP

Part number Parameter	MB89475	MB89P475	MB89PV470
Classification	Mass production products (mask ROM product)	OTP	Piggy-back
ROM size	16 K × 8-bit (internal ROM)	16 K × 8-bit (internal PROM, can be written to by ROM programmer)	32 K × 8-bit (external ROM)
RAM size	512 × 8 bits		1 K × 8 bits
CPU functions	Number of instructions : 136 Instruction bit length : 8 bits Instruction length : 1 to 3 bytes Data bit length : 1, 8, 16 bits Minimum execution time : 0.32 μs/12.5 MHz Minimum interrupt processing time : 2.88 μs/12.5 MHz		
Ports	Output-only ports (N-channel open drain) : 7 pins Input-only ports : 3 pins (1 pin in product with dual clock) I/O ports (CMOS) : 29 pins Total : 39 pins		
21-bit Time-base timer	Interrupt period (0.82 ms, 3.3 ms, 26.2 ms, 419.4 ms) at 10 MHz Interrupt period (0.66 ms, 2.6 ms, 21.0 ms, 335.5 ms) at 12.5 MHz		
Watchdog timer	Reset period (209.7 ms to 419.4 ms) at 10 MHz Reset period (167.8 ms to 335.5 ms) at 12.5 MHz		
Watch prescaler	17 bits Interrupt cycle : 31.25 ms, 0.25 ms, 0.5 s, 1.00 s, 2.00 s, 4.00 s/32.768 kHz for subclock		
Pulse width count timer	2 channels 8-bit one-shot timer operation (supports underflow output, operating clock period : 1, 4, 32 $t_{inst}^*$ , external) 8-bit reload timer operation (supports square wave output, operating clock period : 1, 4, 32 $t_{inst}^*$ , external) 8-bit pulse width measurement operation (supports continuous measurement, H width, L width, rising edge to rising edge, falling edge to falling edge measurement and both edge measurement)		
PWM timer	8-bit reload timer operation (supports square wave output, operating clock period : 1, 4, 32 $t_{inst}^*$ , external) 8-bit resolution PWM operation		
8/16-bit timer/counter 1, 2	Can be operated either as a 2-channel 8-bit timer/counter (Timer 1 and Timer 2, each with its own independent operating clock cycle) , or as one 16-bit timer/counter In Timer 1 or 16-bit timer/counter operation, event counter operation (external clock-triggered) and square wave output capable		
8/16-bit timer/counter 3, 4	Can be operated either as a 2-channel 8-bit timer/counter (Timer 3 and Timer 4, each with its own independent operating clock cycle) , or as one 16-bit timer/counter In Timer 3 or 16-bit timer/counter operation, event counter operation (external clock-triggered) and square wave output capable		
External interrupt	4 independent channels (selectable edge, interrupt vector, request flag) 5 channels (low level interrupt)		

(Continued)

# MB89470 Series

(Continued)

Part number Parameter	MB89475	MB89P475	MB89PV470
A/D converter	10-bit resolution × 8 channels A/D conversion function (conversion time : 60 t <sub>inst</sub> *) Supports repeated activation by internal clock.		
UART/SIO	Synchronous/asynchronous data transfer capable (Max baud rate : 78.125 Kbps at 10 MHz) (7 and 8 bits with parity bit ; 8 and 9 bits without parity bit)		
Buzzer output	7 frequency types (F <sub>CH</sub> /2 <sup>12</sup> , F <sub>CH</sub> /2 <sup>11</sup> , F <sub>CH</sub> /2 <sup>10</sup> , F <sub>CH</sub> /2 <sup>9</sup> , F <sub>CL</sub> /2 <sup>5</sup> , F <sub>CL</sub> /2 <sup>4</sup> , F <sub>CL</sub> /2 <sup>3</sup> ) are selectable by software.		
Standby mode	Sleep mode, stop mode, subclock mode (dual clock product) and watch mode (dual clock product)		
Process	CMOS		
Operating Voltage	2.2 V to 5.5 V	3.5 V to 5.5 V	2.7 V to 5.5 V

\* : t<sub>inst</sub> is one instruction cycle (execution time) , which can be selected as 1/4, 1/8, 1/16, or 1/64 of main clock.

## ■ PACKAGE AND CORRESPONDING PRODUCTS

Part number Package	MB89475	MB89P475	MB89PV470
DIP-48P-M01	O	O	X
FPT-48P-M26	O	O	X
FPT-48P-M13	O	O	X
MQP-48C-P01	X	X	O

O : Available

X : Not available

## ■ DIFFERENCES AMONG PRODUCTS

### 1. Memory Size

Before evaluating using the piggyback product, verify its differences from the product that will actually be used. Take particular care on the following point :

- The stack area, etc., is set at the upper limit of the RAM.

### 2. Current Consumption

- For the MB89PV470, add the current consumed by the EPROM mounted in the piggy-back socket.
- When operating at low speed, the current consumed by the one-time PROM product is greater than that for the mask ROM product. However, the current consumption are roughly the same in sleep or stop mode.
- For more information, see “■ ELECTRICAL CHARACTERISTICS”.

### 3. Oscillation stabilization time after power-on reset

- For MB89PV470, there is no power-on stabilization time after power-on reset.
- For MB89P475, there is power-on stabilization time after power-on reset.
- For MB89475, the power-on stabilization time can be select.
- For more information, refer to “■ MASK OPTIONS”.

## ■ PIN ASSIGNMENTS

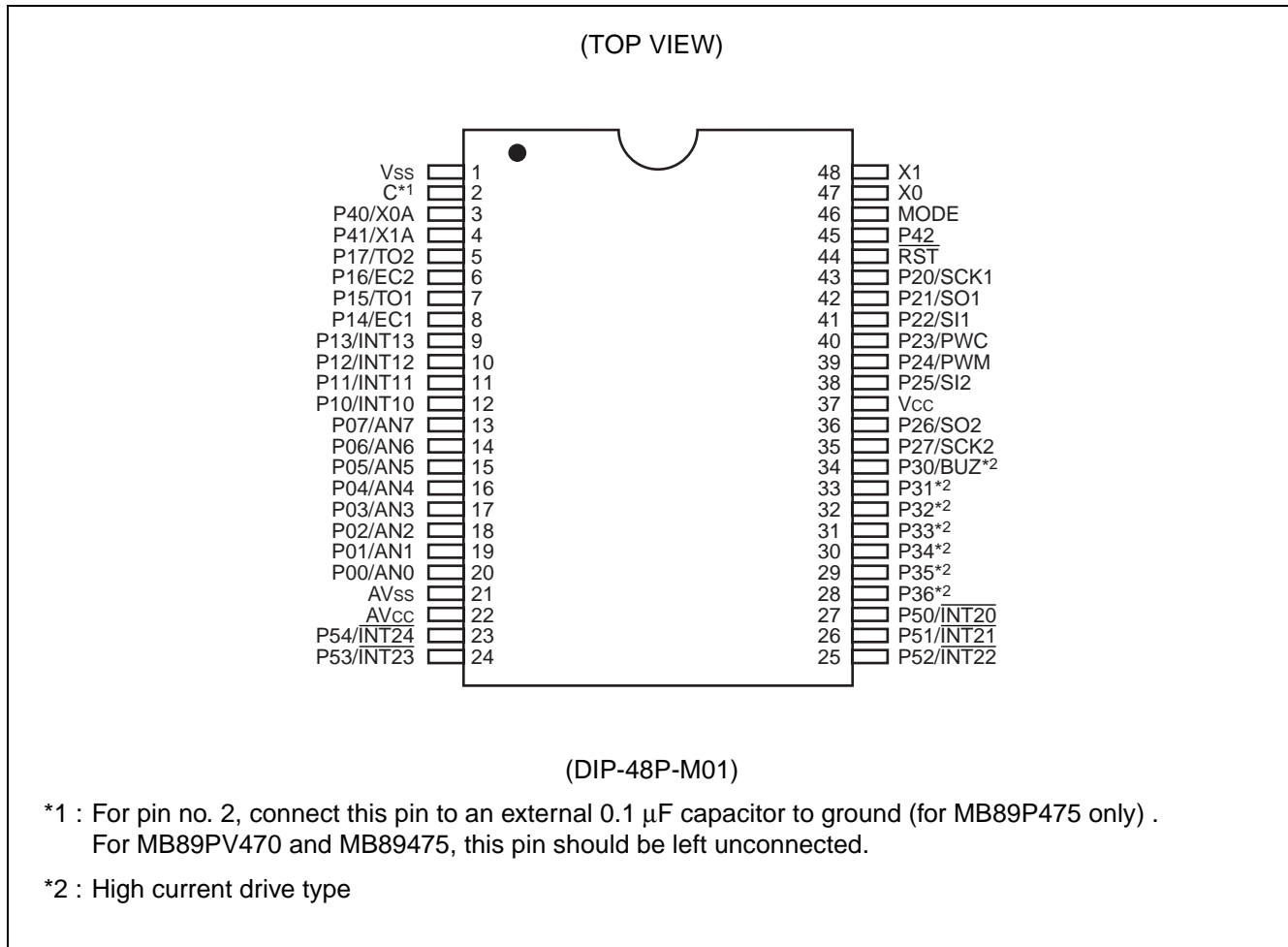

(Continued)

# MB89470 Series

(TOP VIEW)

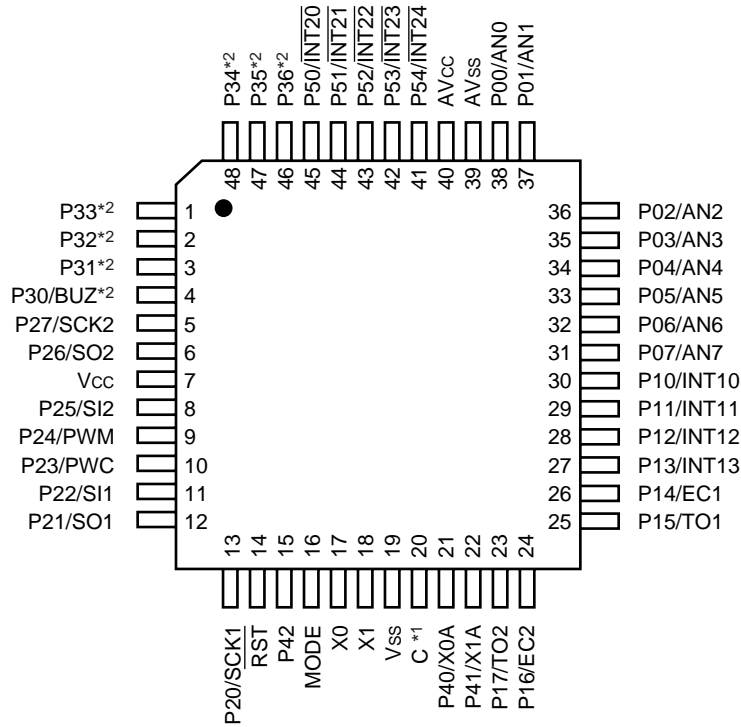

(FPT-48P-M26)

(FPT-48P-M13)

\*1 : For pin no. 20, connect this pin to an external 0.1  $\mu$ F capacitor to ground (for MB89P475 only) .  
For MB89PV470 and MB89475, this pin should be left unconnected.

\*2 : High current drive type

(Continued)

(Continued)

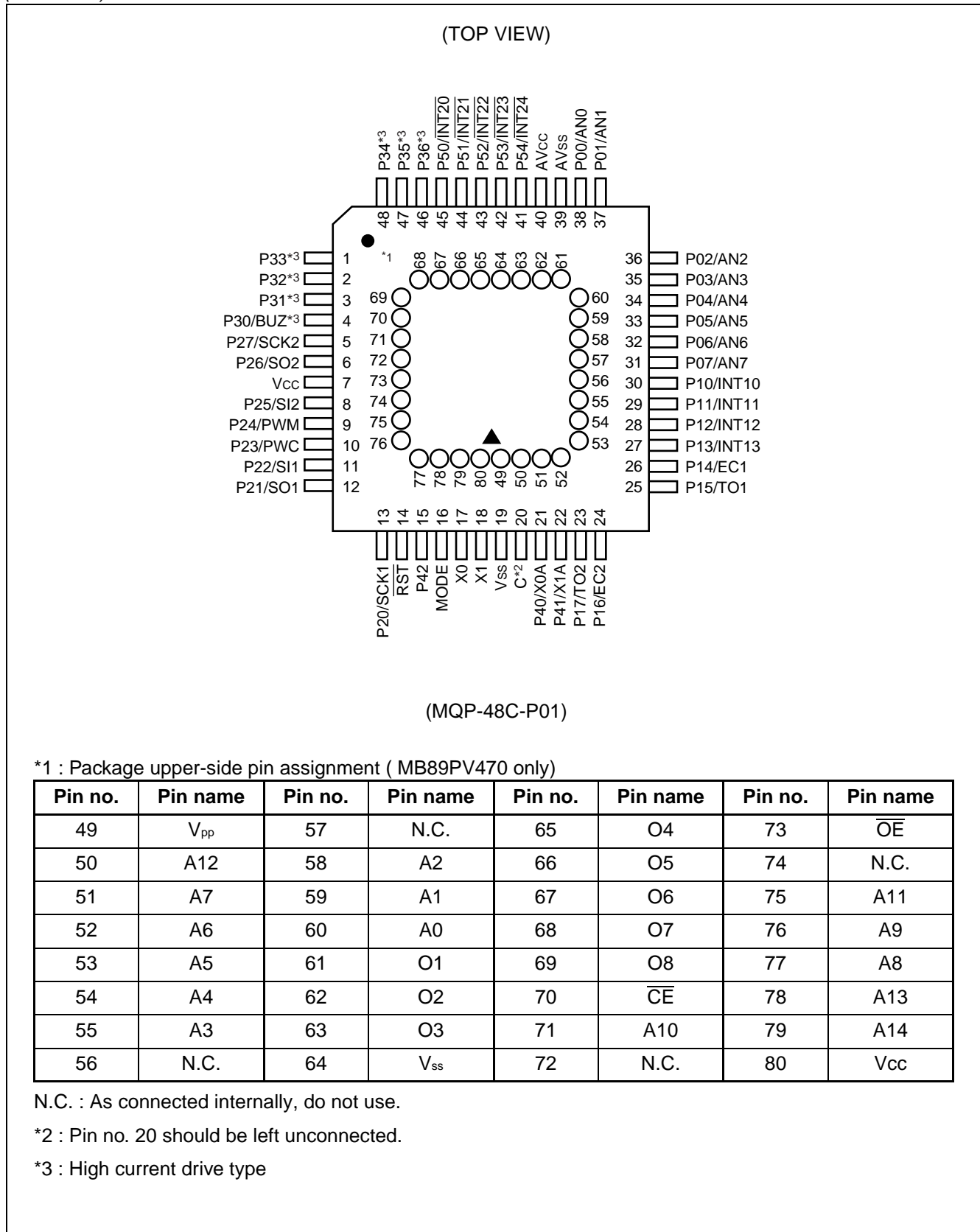

# MB89470 Series

## ■ PIN DESCRIPTION

Pin no.		Pin name	I/O circuit	Function
LQFP/QFP/MQFP*2	SDIP*1			
17	47	X0	A	Connection pins for a crystal or other oscillator. An external clock can be connected to X0. In this case, leave X1 open.
18	48	X1		
16	46	MODE	B	Input pins for setting the memory access mode. Connect directly to V <sub>SS</sub> .
14	44	$\overline{\text{RST}}$	C	Reset I/O pin. The pin is a N-ch open-drain type with pull-up resistor and a hysteresis input. The pin outputs an "L" level when an internal reset request is present. Inputting an "L" level initializes internal circuits.
38 to 31	20 to 13	P00/AN0 to P07/AN7	D	General-purpose I/O port. The pins are shared with the analog inputs for the A/D converter.
30 to 27	12 to 9	P10/INT10 to P13/INT13	E	General-purpose I/O port. A hysteresis input for INT10 to INT13. The pin is shared with an external interrupt 1 input.
26	8	P14/EC1	E	General-purpose I/O port. A hysteresis input for EC1. The pin is shared with the 8/16 bit timer 1 input.
25	7	P15/TO1	F	General-purpose I/O port. The pin is shared with the output of 8/16-bit timer 1.
24	6	P16/EC2	E	General-purpose I/O port. A hysteresis input for EC2. The pin is shared with the 8/16 bit timer 2 input.
23	5	P17/TO2	F	General-purpose I/O port. The pin is shared with the output of 8/16-bit timer 2.
13	43	P20/SCK1	E	General-purpose I/O port. A hysteresis input for SCK1. The pin is shared with the clock I/O of UART/SIO 1.
12	42	P21/SO1	F	General-purpose I/O port. The pin is shared with the serial data output of UART/SIO 1.
11	41	P22/SI1	E	General-purpose I/O port. A hysteresis input for SI1. The pin is shared with the serial data input of UART/SIO 1.
10	40	P23/PWC	E	General-purpose I/O port. A hysteresis input for PWC. This pin is shared with PWC input.
9	39	P24/PWM	F	General-purpose input port. This pin is shared with PWM output.
8	38	P25/SI2	E	General-purpose I/O port. A hysteresis input for SI2. The pin is shared with the serial data input of UART/SIO 2.

(Continued)

# MB89470 Series

(Continued)

Pin no.		Pin name	I/O circuit	Function
LQFP/QFP/MQFP*2	SDIP*1			
6	36	P26/SO2	F	General-purpose I/O port. The pin is shared with the serial data output of UART/SIO 2.
5	35	P27/SCK2	E	General-purpose I/O port. A hysteresis input for SCK2. The pin is shared with the clock I/O of UART/SIO 2.
4	34	P30/BUZ	G	N-channel open-drain output. The pin is shared with buzzer output.
3 to 1, 48 to 46	33 to 28	P31 to P36	G	N-channel open-drain output.
21	3	P40/X0A	H	General-purpose input port. (single clock system)
			A	Connection pins for a crystal or other oscillator. (dual clock system) An external clock can be connected to X0A. In this case, leave X1A open.
22	4	P41/X1A	H	General-purpose input port. (single clock system)
			A	Connection pins for a crystal or other oscillator. (dual clock system) An external clock can be connected to X0A. In this case, leave X1A open.
15	45	P42	H	General-purpose input port.
45 to 41	27 to 23	P50/ $\overline{\text{INT20}}$ to P54/ $\overline{\text{INT24}}$	E	General-purpose I/O port. A hysteresis input for $\overline{\text{INT20}}$ to $\overline{\text{INT24}}$ . The pin is shared with an external interrupt 2 input.
20	2	C	—	Capacitor connection pin *3
7	37	V <sub>CC</sub>	—	Power supply pin (+5 V) .
19	1	V <sub>SS</sub>	—	Power supply pin (GND) .
40	22	AV <sub>CC</sub>	—	A/D converter power supply pin.
39	21	AV <sub>SS</sub>	—	A/D converter power supply pin. Use at the same voltage level as V <sub>SS</sub> .

\*1 : DIP-48P-M01

\*2 : FPT-48P-M26/FPT-48P-M13/MQP-48C-P01

\*3 : When MB89475 or MB89PV470 is used, this pin will become a N.C. pin without internal connection.  
When MB89P475 is used, connect this pin to an external 0.1  $\mu\text{F}$  capacitor to ground.

# MB89470 Series

• External EPROM Socket (MB89PV470 only)

Pin no. MQFP*	Pin name	I/O	Function
49	V <sub>pp</sub>	O	"H" level output pin
50 51 52 53 54 55 58 59 60	A12 A7 A6 A5 A4 A3 A2 A1 A0	O	Address output pins.
61 62 63	O1 O2 O3	I	Data input pins.
64	V <sub>ss</sub>	O	Power supply pin (GND) .
65 66 67 68 69	O4 O5 O6 O7 O8	I	Data input pins.
70	$\overline{CE}$	O	Chip enable pin for the ROM. Outputs "H" in standby mode.
71	A10	O	Address output pin.
73	$\overline{OE}$	O	Output enable pin for the ROM. Always outputs "L".
75 76 77 78 79	A11 A9 A8 A13 A14	O	Address output pins.
80	V <sub>cc</sub>	O	Power supply pin for the EPROM.
56 57 72 74	N.C.	—	Internally connected pins. Always leave open.

\* : MQP-48C-P01

## ■ I/O CIRCUIT TYPE

Type	Circuit	Remarks
A	<p>X1 (X1A) X0 (X0A) Nch Pch Pch Nch Stop mode control signal</p>	<ul style="list-style-type: none"> <li>• Main and sub-clock circuits</li> <li>• Oscillation feedback resistance is approx. 500 kΩ for main clock circuit and 5 MΩ for sub-clock circuit.</li> </ul>
B		<ul style="list-style-type: none"> <li>• Hysteresis input</li> <li>• The pull-down resistor is approx. 50 kΩ. (No pull-down resistor in MB89P475)</li> </ul>
C		<ul style="list-style-type: none"> <li>• The pull-up resistance (P-channel) is approx. 50 kΩ.</li> <li>• Hysteresis input</li> </ul>
D	<p>pull-up resistor register ADIN</p>	<ul style="list-style-type: none"> <li>• CMOS output</li> <li>• CMOS input</li> <li>• Selectable pull-up resistor Approx. 50 kΩ</li> </ul>
E	<p>pull-up resistor register port resource</p>	<ul style="list-style-type: none"> <li>• CMOS output</li> <li>• CMOS input</li> <li>• Selectable pull-up resistor Approx. 50 kΩ</li> </ul>

(Continued)

# MB89470 Series

(Continued)

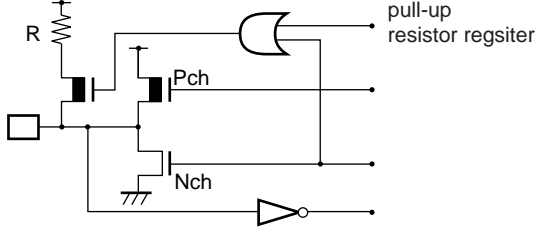
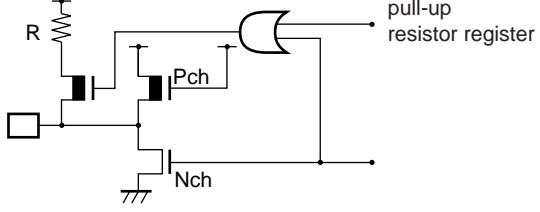
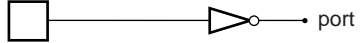
Type	Circuit	Remarks
F		<ul style="list-style-type: none"> <li>• CMOS output</li> <li>• CMOS input</li> <li>• Selectable pull-up resistor Approx. 50 kΩ</li> </ul>
G		<ul style="list-style-type: none"> <li>• N-channel open-drain output</li> <li>• Selectable pull-up resistor Approx. 50 kΩ</li> </ul>
H		<ul style="list-style-type: none"> <li>• CMOS input</li> </ul>

## ■ HANDLING DEVICES

### 1. Preventing Latchup

Latchup may occur on CMOS ICs if voltage higher than  $V_{CC}$  or lower than  $V_{SS}$  is applied to input and output pins other than medium- to high-voltage pins or if higher than the voltage which shows on “1. Absolute Maximum Ratings” in “■ ELECTRICAL CHARACTERISTICS” is applied between  $V_{CC}$  and  $V_{SS}$ .

When latchup occurs, power supply current increases rapidly and might thermally damage elements. When using, take great care not to exceed the absolute maximum ratings.

Also, take care to prevent the analog power supply ( $AV_{CC}$ ) and analog input from exceeding the digital power supply ( $V_{CC}$ ) when the analog system power supply is turned on and off.

### 2. Treatment of Unused Input Pins

Leaving unused input pins open could cause malfunctions. They should be connected to a pull-up or pull-down resistor.

### 3. Treatment of Power Supply Pins on Microcontrollers with A/D Converter

Connect to be  $AV_{CC} = V_{CC}$  and  $AV_{SS} = V_{SS}$  even if the A/D converter is not in use.

### 4. Treatment of N.C. Pins

Be sure to leave (internally connected) N.C. pins open.

### 5. Power Supply Voltage Fluctuations

Although  $V_{CC}$  power supply voltage is assured to operate within the rated range, a rapid fluctuation of the voltage could cause malfunctions, even if it occurs within the rated range. Stabilizing voltage supplied to the IC is therefore important. As stabilization guidelines, it is recommended to control power so that  $V_{CC}$  ripple fluctuations (P-P value) will be less than 10% of the standard  $V_{CC}$  value at the commercial frequency (50 Hz to 60 Hz) and the transient fluctuation rate will be less than 0.1 V/ms at the time of a momentary fluctuation such as when power is switched.

### 6. Precautions when Using an External Clock

Even when an external clock is used, oscillation stabilization time is required for power-on reset (optional) and wake-up from stop mode.

### 7. Note to noise in the External Reset Pin ( $\overline{RST}$ )

If the reset pulse applied to the external reset pin ( $\overline{RST}$ ) does not meet the specifications, it may cause malfunctions. Use caution so that the reset pulse less than the specifications will not be fed to the external reset pin ( $\overline{RST}$ ).

# MB89470 Series

## ■ PROGRAMMING OTPROM IN MB89P475 WITH SERIAL PROGRAMMER

### 1. Programming the OTPROM with serial programmer

- All OTP products can be programmed with serial programmer.

### 2. Programming the OTPROM

- To program the OTPROM using FUJITSU MCU programmer MB91919-001.

Inquiry : Fujitsu Microelectronics Asia Pte Ltd. : TEL (65) -2810770

FAX (65) -2810220

### 3. Programming Adapter for OTPROM

- To program the OTPROM using FUJITSU MCU programmer MB91919-001, use the programming adapter listed below.

Package	Compatible socket adapter
DIP-48P-M01	MB91919-805+MB91919-800
FPT-48P-M26	MB91919-806+MB91919-800
FPT-48P-M13	MB91919-807+MB91919-800

Inquiry : Fujitsu Microelectronics Asia Pte Ltd. : TEL (65) -2810770

FAX (65) -2810220

### 4. OTPROM Content Protection

For product with OTPROM content protection feature (MB89P475-102, MB89P475-202), OTPROM content can be read using serial programmer if the OTPROM content protection mechanism is not activated.

One predefined area of the OTPROM (FFFC<sub>H</sub>) is assigned to be used for preventing the read access of OTPROM content. If the protection code "00<sub>H</sub>" is written in this address (FFFC<sub>H</sub>), the OTPROM content cannot be read by any serial programmer.

Note : The program written into the OTPROM cannot be verified once the OTPROM protection code is written ("00<sub>H</sub>" in FFFC<sub>H</sub>). It is advised to write the OTPROM protection code at last.

### 5. Programming Yield

All bits cannot be programmed at Fujitsu shipping test to a blanked OTPROM microcomputer, due to its nature. For this reason, a programming yield of 100% cannot be assured at all times.

## ■ PROGRAMMING OTPROM IN MB89P475 WITH PROGRAMMER

### 1. Programming OTPROM with parallel programmer

- Only products without protection feature (i.e. MB89P475-101 and MB89P475-201) can be programmed with parallel programmer. Product with protection feature (i.e. MB89P475-102 and MB89P475-202) cannot be programmed with parallel programmer.

### 2. ROM Writer Adapters and Recommended ROM Writers

- The following shows ROM writer adapters and recommended ROM writers.

Fujitsu Microelectronics Asia Pte Ltd. (Serial programmer)

Package	Applicable adapter model	Recommended writer
DIP-48P-M01	MB91919-601	MB91919-001
FPT-48P-M26	MB91919-602	
FPT-48P-M13	MB91919-603	

Inquiries : Fujitsu Microelectronics Asia Pte Ltd. : TEL (65) -2810770

Writing data to the OTPROM

- (1) Set the OTPROM writer for the CU50-OTP (device code : cdB6DC) .
- (2) Load the program data to the OTPROM writer.
- (3) Write data using the OTPROM writer.

### 3. Programming Yield

All bits cannot be programmed at Fujitsu shipping test to a blanked OTPROM microcomputer, due to its nature. For this reason, a programming yield of 100% cannot be assured at all times.

# MB89470 Series

## ■ PROGRAMMING TO THE EPROM WITH PIGGYBACK/EVALUATION DEVICE

### 1. EPROM for Use

MBM27C256A-20TVM

### 2. Memory Space

Memory space in each mode is diagrammed below.

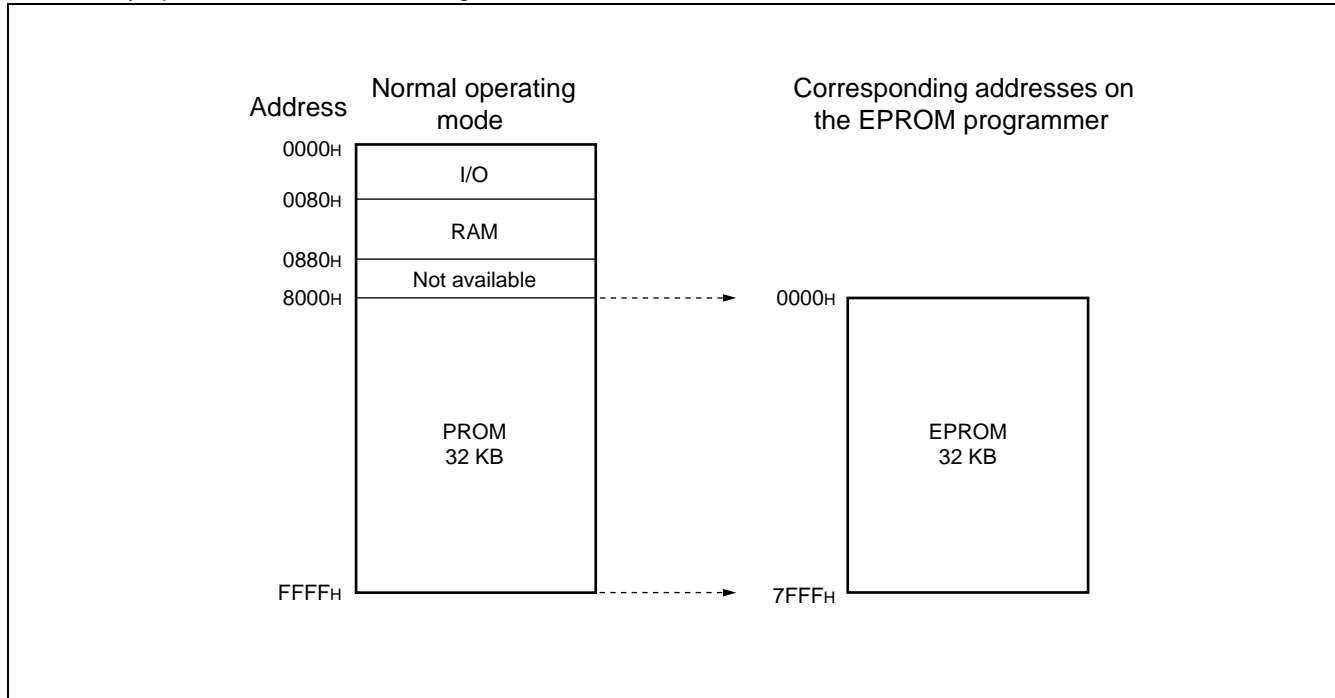

### 3. Programming to the EPROM

- (1) Set the EPROM programmer to the MBM27C256.
- (2) Load program data into the EPROM programmer at 0000H to 7FFFH.
- (3) Program to 0000H to 7FFFH with the EPROM programmer.

## ■ BLOCK DIAGRAM

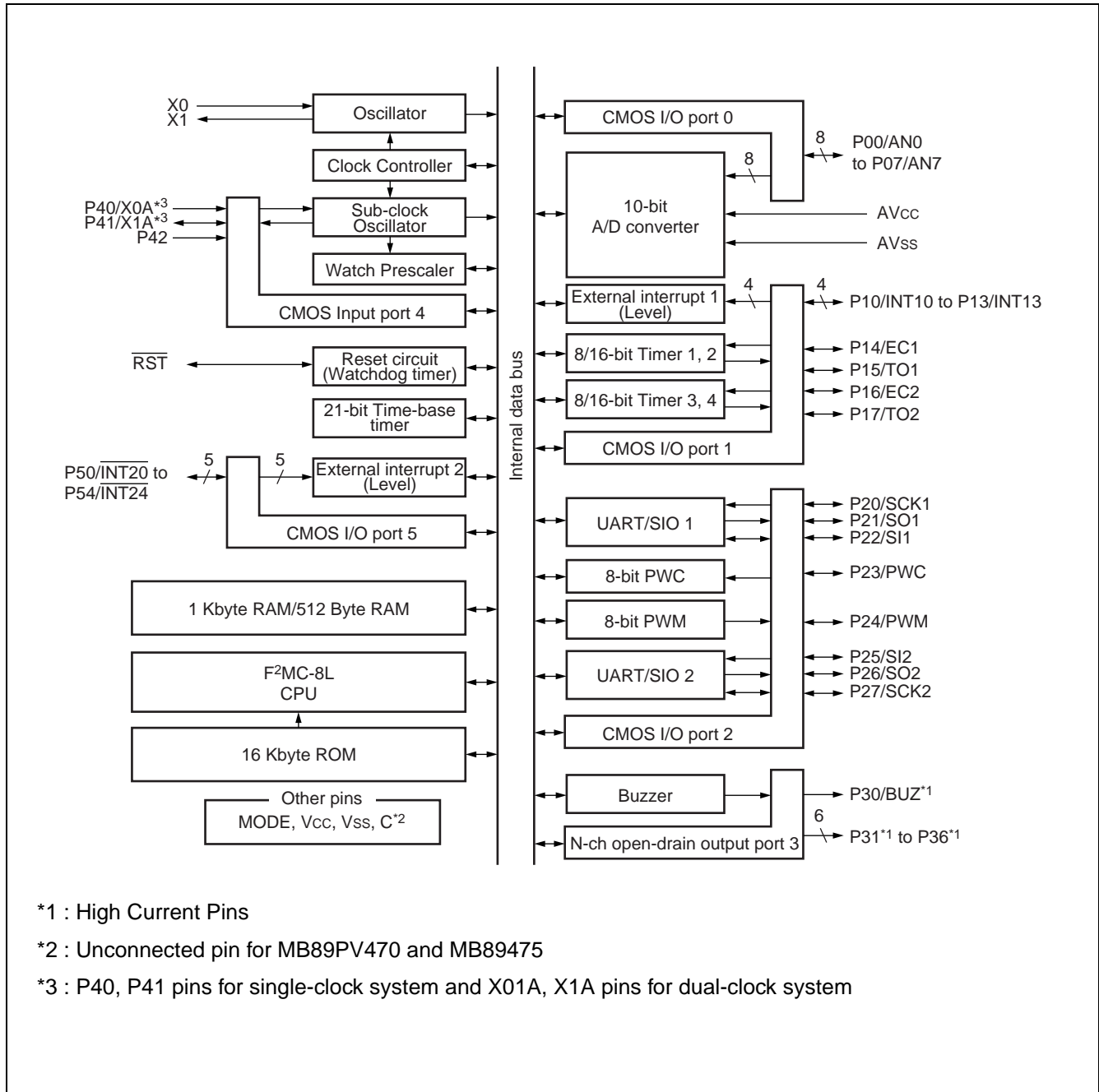

# MB89470 Series

## ■ CPU CORE

### 1. Memory Space

The microcontrollers of the MB89470 series offer a memory space of 64 Kbytes for storing all of I/O, data, and program areas. The I/O area is located at the lowest address. The data area is provided immediately above the I/O area. The data area can be divided into register, stack, and direct areas according to the application. The program area is located at exactly the opposite end, that is, near the highest address. Provide the tables of interrupt reset vectors and vector call instructions toward the highest address within the program area. The memory space of the MB89470 series is structured as illustrated below.

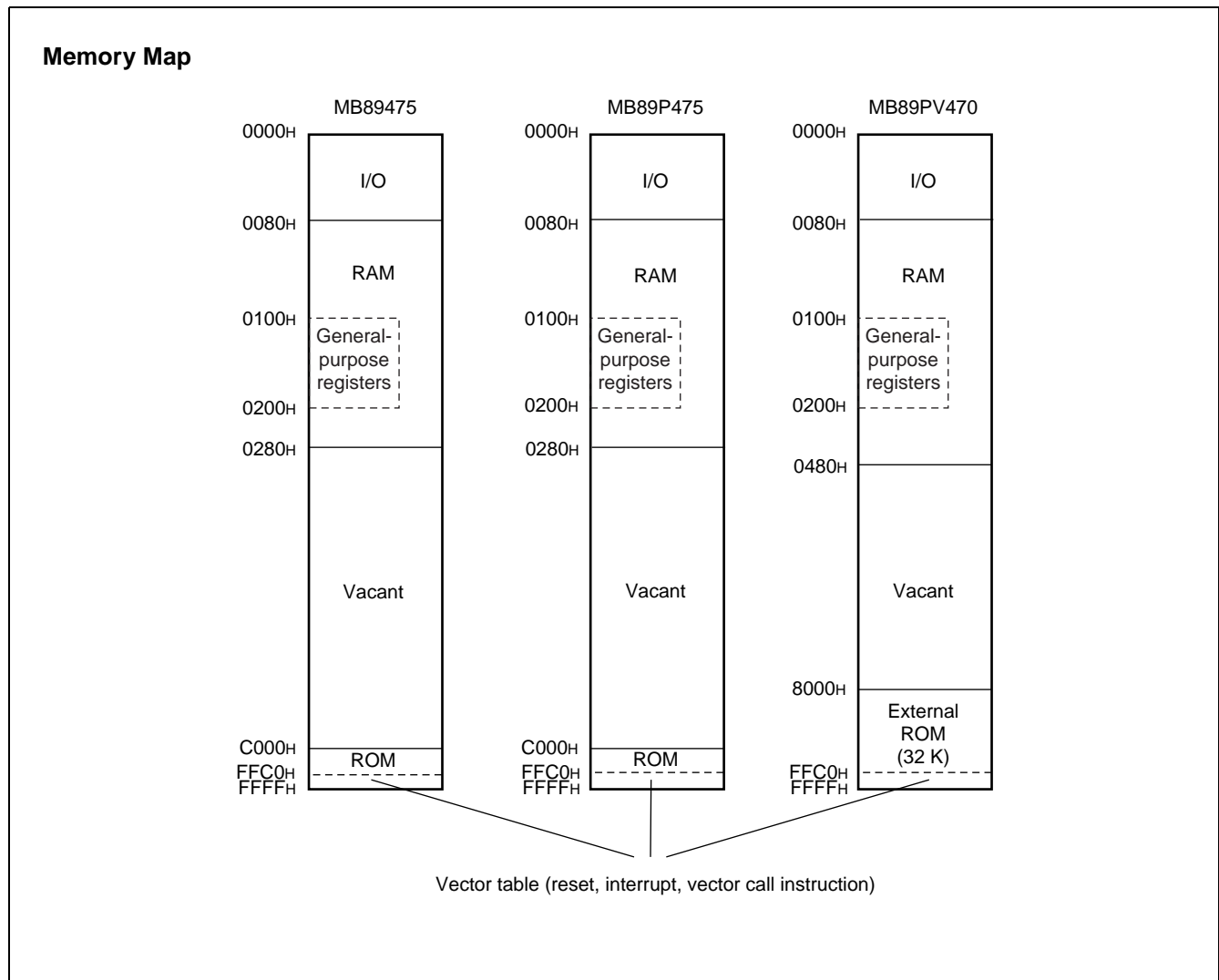

## 2. Registers

The F<sup>2</sup>MC-8L family has two types of registers; dedicated registers in the CPU and general-purpose registers in the memory. The following registers are provided :

- Program counter (PC) : A 16-bit register for indicating instruction storage positions
- Accumulator (A) : A 16-bit temporary register for storing arithmetic operations, etc. When the instruction is an 8-bit data processing instruction, the lower byte is used.
- Temporary accumulator (T) : A 16-bit register which performs arithmetic operations with the accumulator. When the instruction is an 8-bit data processing instruction, the lower byte is used.
- Index register (IX) : A 16-bit register for index modification
- Extra pointer (EP) : A 16-bit pointer for indicating a memory address
- Stack pointer (SP) : A 16-bit register for indicating a stack area
- Program status (PS) : A 16-bit register for storing a register pointer, a condition code

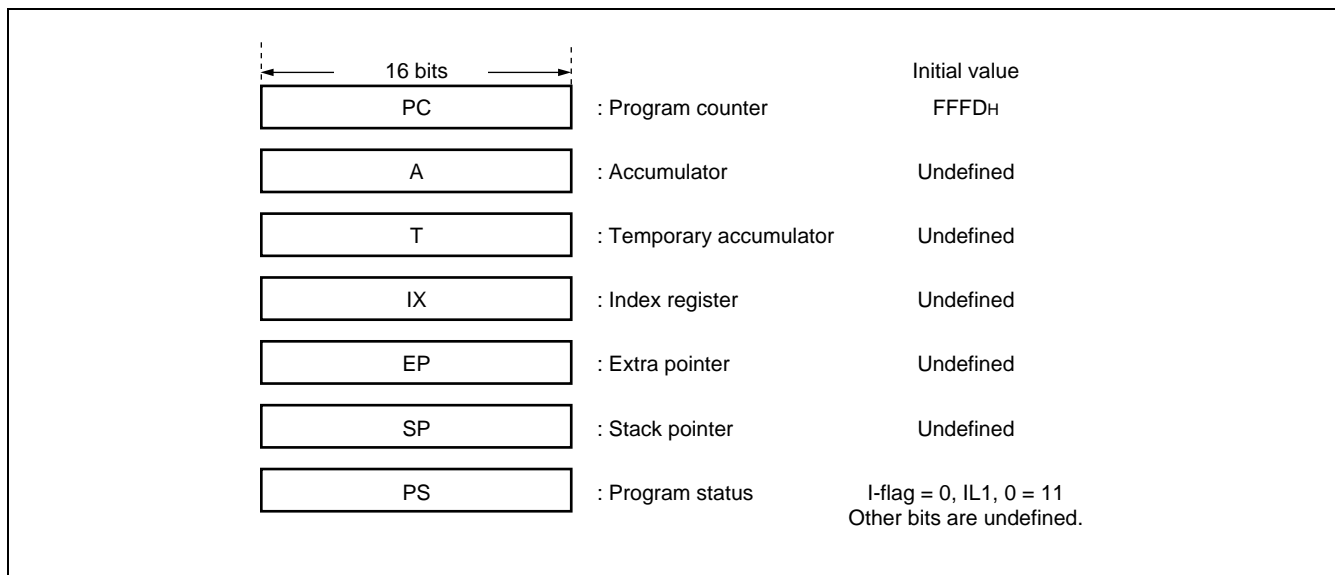

The PS can further be divided into higher 8 bits for use as a register bank pointer (RP) and the lower 8 bits for use as a condition code register (CCR) . (See the diagram below.)

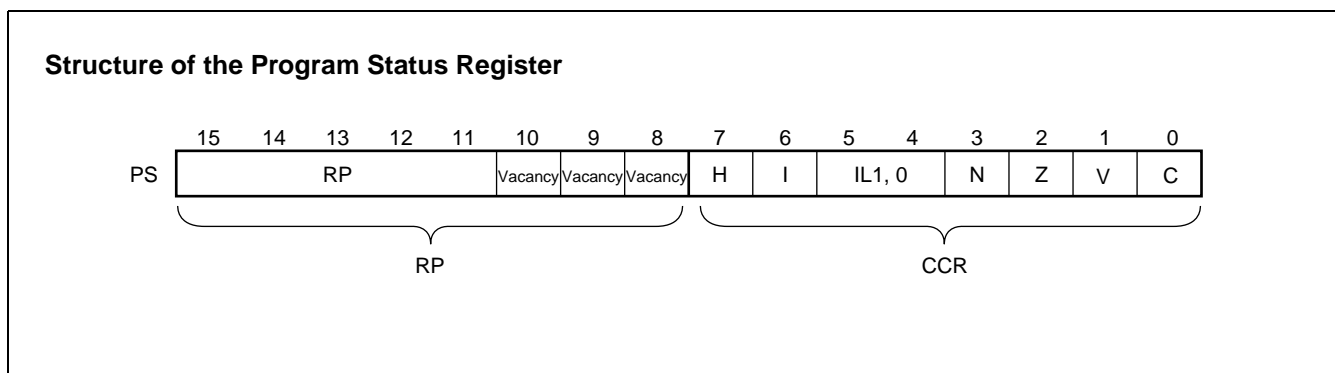

# MB89470 Series

The RP indicates the address of the register bank currently in use. The relationship between the pointer contents and the actual address is based on the conversion rule illustrated below.

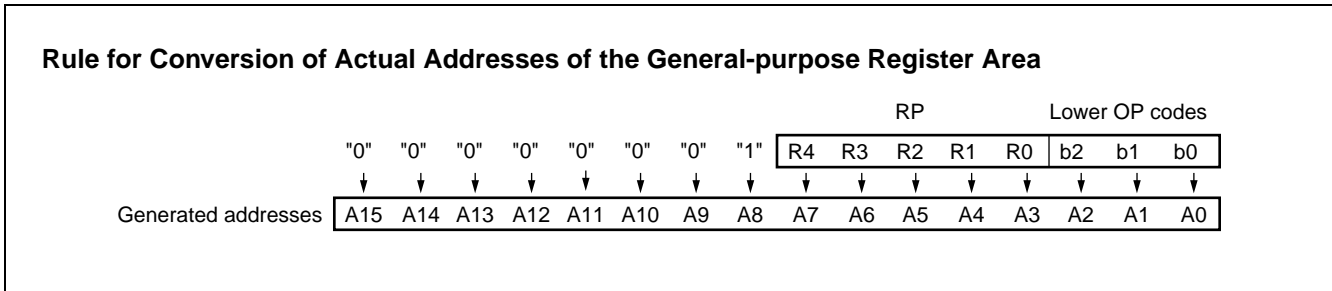

The CCR consists of bits indicating the results of arithmetic operations and the contents of transfer data and bits for control of CPU operations at the time of an interrupt.

- H-flag : Set when a carry or a borrow from bit 3 to bit 4 occurs as a result of an arithmetic operation. Cleared otherwise. This flag is for decimal adjustment instructions.
- I-flag : Interrupt is allowed when this flag is set to 1. Interrupt is prohibited when the flag is set to 0. Set to 0 when reset.
- IL1, 0 : Indicates the level of the interrupt currently allowed. Processes an interrupt only if its request level is higher than the value indicated by this bit.

IL1	IL0	Interrupt level	High-low
0	0	1	High ↑ ↓ Low = no interrupt
0	1		
1	0	2	
1	1	3	

- N-flag : Set if the MSB is set to 1 as the result of an arithmetic operation. Cleared when the bit is set to 0.
- Z-flag : Set when an arithmetic operation results in 0. Cleared otherwise.
- V-flag : Set if the complement on 2 overflows as a result of an arithmetic operation. Reset if the overflow does not occur.
- C-flag : Set when a carry or a borrow from bit 7 occurs as a result of an arithmetic operation. Cleared otherwise. Set to the shift-out value in the case of a shift instruction.

The following general-purpose registers are provided :

General-purpose registers : An 8-bit register for storing data

The general-purpose registers are 8 bits and located in the register banks of the memory. One bank contains eight registers. Up to a total of 32 banks can be used on the MB89470 series. The bank currently in use is indicated by the register bank pointer (RP) .

## Register Bank Configuration

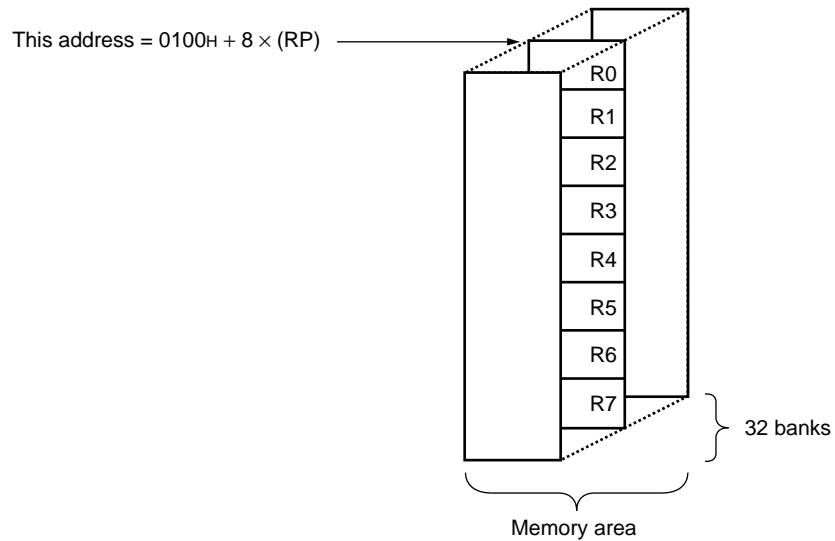

# MB89470 Series

## ■ I/O MAP

Address	Register name	Register Description	Read/Write	Initial value
00H	PDR0	Port 0 data register	R/W	XXXXXXXX <sub>B</sub>
01H	DDR0	Port 0 data direction register	W*	00000000 <sub>B</sub>
02H	PDR1	Port 1 data register	R/W	XXXXXXXX <sub>B</sub>
03H	DDR1	Port 1 data direction register	W*	00000000 <sub>B</sub>
04H	PDR2	Port 2 data register	R/W	00000000 <sub>B</sub>
05H	(Reserved)			
06H	DDR2	Port 2 data direction register	R/W	00000000 <sub>B</sub>
07H	SYCC	System clock control register	R/W	-XXMM-00 <sub>B</sub>
08H	STBC	Standby control register	R/W	0001XXXX <sub>B</sub>
09H	WDTC	Watchdog timer control register	W*	0---XXXX <sub>B</sub>
0AH	TBTC	Timebase timer control register	R/W	00---000 <sub>B</sub>
0BH	WPCR	Watch prescaler control register	R/W	00--0000 <sub>B</sub>
0CH	PDR3	Port 3 data register	R/W	-1111111 <sub>B</sub>
0DH	PDR4	Port 4 data register	R	----XX <sub>B</sub>
0EH	RSFR	Reset flag register	R	XXXX---- <sub>B</sub>
0FH	BUZR	Buzzer register	R/W	----000 <sub>B</sub>
10H	PDR5	Port 5 data register	R/W	---XXXX <sub>B</sub>
11H	DDR5	Port 5 data direction register	R/W	---0000 <sub>B</sub>
12H, 13H	(Reserved)			
14H	T4CR	Timer 4 control register	R/W	000000X0 <sub>B</sub>
15H	T3CR	Timer 3 control register	R/W	000000X0 <sub>B</sub>
16H	T4DR	Timer 4 data register	R/W	XXXXXXXX <sub>B</sub>
17H	T3DR	Timer 3 data register	R/W	XXXXXXXX <sub>B</sub>
18H	T2CR	Timer 2 control register	R/W	000000X0 <sub>B</sub>
19H	T1CR	Timer 1 control register	R/W	000000X0 <sub>B</sub>
1AH	T2DR	Timer 2 data register	R/W	XXXXXXXX <sub>B</sub>
1BH	T1DR	Timer 1 data register	R/W	XXXXXXXX <sub>B</sub>
1CH to 1FH	(Reserved)			
20H	ADC1	A/D control register 1	R/W	-00000X0 <sub>B</sub>
21H	ADC2	A/D control register 2	R/W	-0000001 <sub>B</sub>
22H	ADDH	A/D data register (Upper byte)	R	-----XX <sub>B</sub>
23H	ADDL	A/D data register (Lower byte)	R	XXXXXXXX <sub>B</sub>
24H	ADER	A/D input enable register	R/W	11111111 <sub>B</sub>
25H	(Reserved)			
26H	SMC11	UART/SIO serial mode control register 11	R/W	00000000 <sub>B</sub>

(Continued)

(Continued)

Address	Register name	Register Description	Read/Write	Initial value
27 <sub>H</sub>	SMC12	UART/SIO serial mode control register 12	R/W	00000000 <sub>B</sub>
28 <sub>H</sub>	SSD1	UART/SIO serial status and data register 1	R	00001--- <sub>B</sub>
29 <sub>H</sub>	SIDR1/SODR1	UART/SIO serial data register 1	R/W *	XXXXXXXX <sub>B</sub>
2A <sub>H</sub>	SRC1	UART/SIO serial rate control register 1	R/W	XXXXXXXX <sub>B</sub>
2B <sub>H</sub>	SMC21	UART serial mode control register 21	R/W	00000000 <sub>B</sub>
2C <sub>H</sub>	SMC22	UART serial mode control register 22	R/W	00000000 <sub>B</sub>
2D <sub>H</sub>	SSD2	UART serial status and data register 2	R	00001--- <sub>B</sub>
2E <sub>H</sub>	SIDR2/SODR2	UART serial data register 2	R/W *	XXXXXXXX <sub>B</sub>
2F <sub>H</sub>	SRC2	UART serial rate control register 2	R/W	XXXXXXXX <sub>B</sub>
30 <sub>H</sub>	EIC1	External interrupt 1 control register 1	R/W	00000000 <sub>B</sub>
31 <sub>H</sub>	EIC2	External interrupt 1 control register 2	R/W	00000000 <sub>B</sub>
32 <sub>H</sub>	EIE2	External interrupt 2 enable register	R/W	---00000 <sub>B</sub>
33 <sub>H</sub>	EIF2	External interrupt 2 flag register	R/W	-----0 <sub>B</sub>
34 <sub>H</sub>	PCR1	PWC control register 1	R/W	0-0--000 <sub>B</sub>
35 <sub>H</sub>	PCR2	PWC control register 2	R/W	00000000 <sub>B</sub>
36 <sub>H</sub>	PLBR	PWC reload buffer register	R/W	XXXXXXXX <sub>B</sub>
37 <sub>H</sub>	(Reserved)			
38 <sub>H</sub>	CNTR	PWM timer control register	R/W	0-00000000 <sub>B</sub>
39 <sub>H</sub>	COMR	PWM timer compare register	W*	XXXXXXXX <sub>B</sub>
3A <sub>H</sub> to 6F <sub>H</sub>	(Reserved)			
70 <sub>H</sub>	PURC0	Port 0 pull up resistor control register	R/W	11111111 <sub>B</sub>
71 <sub>H</sub>	PURC1	Port 1 pull up resistor control register	R/W	11111111 <sub>B</sub>
72 <sub>H</sub>	PURC2	Port 2 pull up resistor control register	R/W	11111111 <sub>B</sub>
73 <sub>H</sub>	PURC3	Port 3 pull up resistor control register	R/W	-11111111 <sub>B</sub>
74 <sub>H</sub>	(Reserved)			
75 <sub>H</sub>	PURC5	Port 5 pull up resistor control register	R/W	---1111 <sub>B</sub>
76 <sub>H</sub> to 7A <sub>H</sub>	(Reserved)			
7B <sub>H</sub>	ILR1	Interrupt level setting register 1	W*	11111111 <sub>B</sub>
7C <sub>H</sub>	ILR2	Interrupt level setting register 2	W*	11111111 <sub>B</sub>
7D <sub>H</sub>	ILR3	Interrupt level setting register 3	W*	11111111 <sub>B</sub>
7E <sub>H</sub>	ILR4	Interrupt level setting register 4	W*	11111111 <sub>B</sub>
7F <sub>H</sub>	(Reserved)			

\* : Bit manipulation instruction cannot be used.

# MB89470 Series

- **Read/write access symbols**

R/W : Readable and writable

R : Read-only

W : Write-only

- **Initial value symbols**

0 : The initial value of this bit is "0".

1 : The initial value of this bit is "1".

X : The initial value of this bit is undefined.

- : Unused bit.

M : The initial value of this bit is determined by mask option.

## ■ ELECTRICAL CHARACTERISTICS

### 1. Absolute Maximum Ratings

( $V_{SS} = V_{SS} = 0.0\text{ V}$ )

Parameter	Symbol	Value		Unit	Remarks
		Min	Max		
Power supply voltage	$V_{CC}$ $AV_{CC}$	$V_{SS} - 0.3$	$V_{SS} + 6.0$	V	$AV_{CC}$ must not exceed $V_{CC}$
Input voltage	$V_I$	$V_{SS} - 0.3$	$V_{CC} + 0.3$	V	
Output voltage	$V_O$	$V_{SS} - 0.3$	$V_{CC} + 0.3$	V	
“L” level maximum output current	$I_{OL}$	—	15	mA	
“L” level average output current	$I_{OLAV1}$	—	4	mA	Average value (operating current × operating rate) P00 to P07, P10 to P17, P20 to P27, P50 to P54, $\overline{RST}$
	$I_{OLAV2}$	—	12	mA	Average value (operating current × operating rate) P30 to P36
“L” level total maximum output current	$\Sigma I_{OL}$	—	100	mA	
“L” level total average output current	$\Sigma I_{OLAV}$	—	40	mA	Average value (operating current × operating rate)
“H” level maximum output current	$I_{OH}$	—	-15	mA	
“H” level average output current	$I_{OHAV}$	—	-2	mA	Average value (operating current × operating rate)
“H” level total maximum output current	$\Sigma I_{OH}$	—	-50	mA	
“H” level total average output current	$\Sigma I_{OHAV}$	—	-20	mA	Average value (operating current × operating rate)
Power consumption	$P_D$	—	300	mW	
Operating temperature	$T_A$	-40	+85	°C	
Storage temperature	$T_{stg}$	-55	+150	°C	

WARNING: Semiconductor devices can be permanently damaged by application of stress (voltage, current, temperature, etc.) in excess of absolute maximum ratings. Do not exceed these ratings.

# MB89470 Series

## 2. Recommended Operating Conditions

( $AV_{SS} = V_{SS} = 0.0\text{ V}$ )

Parameter	Symbol	Value		Unit	Remarks	
		Min	Max			
Power supply voltage	$V_{CC}$ $AV_{CC}$	2.2*	5.5	V	Operation assurance range	MB89475
		3.5*	5.5	V	Operation assurance range	MB89P475
		2.7*	5.5	V	Operation assurance range	MB89PV470
		1.5	5.5	V	Retains the RAM state in stop mode	
Operating temperature	$T_A$	-40	+85	°C		

\* : These values depend on the operating conditions and the analog assurance range. See “Operating Voltage vs. Main Clock Operating Frequency” and “5. A/D Converter Electrical Characteristics.”

• Operating Voltage vs. Main Clock Operating Frequency

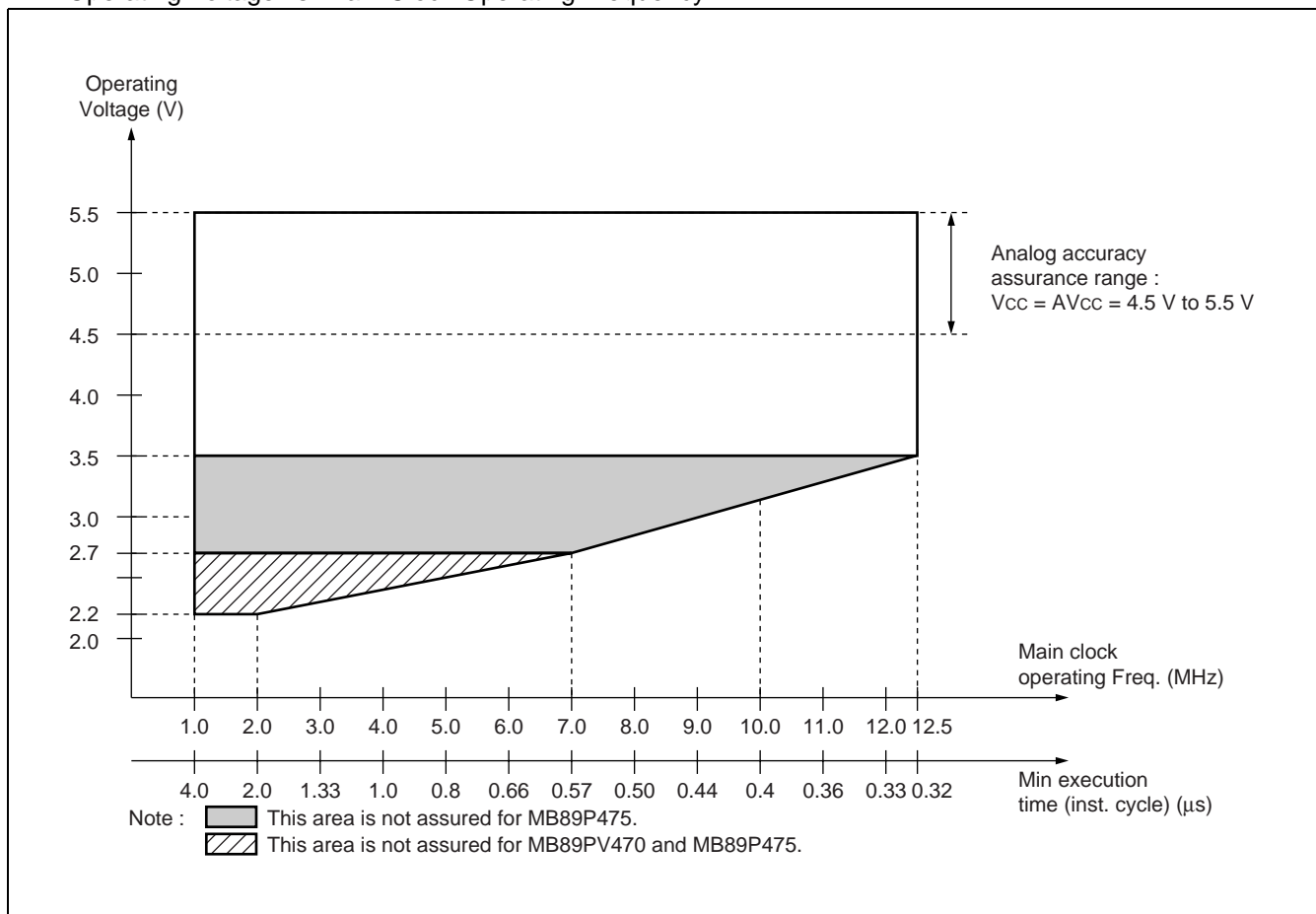

“Operating Voltage vs. Main Clock Operating Frequency” indicates the operating frequency of the external oscillator at an instruction cycle of  $4/F_{CH}$ .

Since the operating voltage range is dependent on the instruction cycle, see minimum execution time if the operating speed is switched using a gear.

**WARNING:** The recommended operating conditions are required in order to ensure the normal operation of the semiconductor device. All of the device's electrical characteristics are warranted when the device is operated within these ranges.

Always use semiconductor devices within their recommended operating condition ranges. Operation outside these ranges may adversely affect reliability and could result in device failure.

No warranty is made with respect to uses, operating conditions, or combinations not represented on the data sheet. Users considering application outside the listed conditions are advised to contact their representatives beforehand.

# MB89470 Series

## 3. DC Characteristics

( $V_{CC} = V_{CC} = 5.0\text{ V}$ ,  $V_{SS} = V_{SS} = 0.0\text{ V}$ ,  $T_A = -40\text{ }^\circ\text{C}$  to  $+85\text{ }^\circ\text{C}$ )

Parameter	Symbol	Pin	Condition	Value			Unit	Remarks
				Min	Typ	Max		
"H" level input voltage	$V_{IH}$	P00 to P07, P10 to P17, P20 to P27, P40 to P42, P50 to P54	—	$0.7 V_{CC}$	—	$V_{CC} + 0.3$	V	
	$V_{IHS}$	$\overline{RST}$ , MODE, EC1, EC2, SCK1, SI1, SCK2, SI2, PWC, INT10 to INT13, $\overline{INT20}$ to $\overline{INT24}$	—	$0.8 V_{CC}$	—	$V_{CC} + 0.3$	V	
"L" level input voltage	$V_{IL}$	P00 to P07, P10 to P17, P20 to P27, P40 to P42, P50 to P54	—	$V_{SS} - 0.3$	—	$0.3 V_{CC}$	V	
	$V_{ILS}$	$\overline{RST}$ , MODE, EC1, EC2, SCK1, SI1, SCK2, SI2, PWC, INT10 to INT13, $\overline{INT20}$ to $\overline{INT24}$	—	$V_{SS} - 0.3$	—	$0.2 V_{CC}$	V	
Open-drain output pin application voltage	$V_D$	P30 to P36	—	$V_{SS} - 0.3$	—	$V_{CC} + 0.3$	V	
"H" level output voltage	$V_{OH}$	P00 to P07, P10 to P17, P20 to P27, P50 to P54	$I_{OH} = -2.0\text{ mA}$	4.0	—	—	V	
"L" level output voltage	$V_{OL1}$	P00 to P07, P10 to P17, P20 to P27, P50 to P54, $\overline{RST}$	$I_{OL} = 4.0\text{ mA}$	—	—	0.4	V	
	$V_{OL2}$	P30 to P36	$I_{OL} = 12.0\text{ mA}$	—	—	0.4	V	
Input leakage current	$I_{LI}$	P00 to P07, P10 to P17, P20 to P27, P50 to P54	$0.45\text{ V} < V_I < V_{CC}$	-5	—	+5	$\mu\text{A}$	Without pull-up resistor
Open drain output leakage current	$I_{LOD}$	P30 to P36	$0.45\text{ V} < V_I < V_{CC}$	-5	—	+5	$\mu\text{A}$	

(Continued)

# MB89470 Series

(Continued)

( $AV_{CC} = V_{CC} = 5.0\text{ V}$ ,  $AV_{SS} = V_{SS} = 0.0\text{ V}$ ,  $T_A = -40\text{ }^\circ\text{C}$  to  $+85\text{ }^\circ\text{C}$ )

Parameter	Symbol	Pin	Condition	Value			Unit	Remarks
				Min	Typ	Max		
Pull-down resistance	$R_{DOWN}$	MODE	$V_I = V_{CC}$	25	50	100	$k\Omega$	Except MB89P475
Pull-up resistance	$R_{PULL}$	P00 to P07, P10 to P17, P20 to P27, P30 to P36, P50 to P54, $\overline{RST}$	$V_I = 0.0\text{ V}$	25	50	100	$k\Omega$	When pull-up resistor is selected (except $\overline{RST}$ )
Power supply current	$I_{CC1}$	$V_{CC}$	$F_{CH} = 12.5\text{ MHz}$ $t_{inst} = 0.32\text{ }\mu\text{s}$ Main clock run mode	—	7	13	mA	
	$I_{CC2}$		$F_{CH} = 12.5\text{ MHz}$ $t_{inst} = 5.12\text{ }\mu\text{s}$ Main clock run mode	—	1	3	mA	
	$I_{CCS1}$		$F_{CH} = 12.5\text{ MHz}$ $t_{inst} = 0.32\text{ }\mu\text{s}$ Main clock sleep mode	—	2.5	5	mA	
	$I_{CCS2}$		$F_{CH} = 12.5\text{ MHz}$ $t_{inst} = 5.12\text{ }\mu\text{s}$ Main clock sleep mode	—	0.7	2	mA	
	$I_{CCL}$		$F_{CL} =$ 32.768 kHz Subclock mode	—	37	85	$\mu\text{A}$	MB89PV470 MB89475
			—	—	350	785	$\mu\text{A}$	MB89P475
	$I_{CCLS}$		$F_{CL} =$ 32.768 kHz Subclock sleep mode	—	11	30	$\mu\text{A}$	
	$I_{CCT}$		$F_{CL} =$ 32.768 kHz Watch mode	—	1.4	15	$\mu\text{A}$	MB89PV470 MB89475
			Main clock stop mode	—	5.6	21	$\mu\text{A}$	MB89P475
	$I_{CCH}$	$T_A = +25\text{ }^\circ\text{C}$ Subclock stop mode	—	1	10	$\mu\text{A}$		
$I_A$	$AV_{CC}$	$F_{CH} = 12.5\text{ MHz}$	—	2.8	6	mA	A/D converting	
		$T_A = +25\text{ }^\circ\text{C}$	—	1	5	$\mu\text{A}$	A/D stop	
Input capacitance	$C_{IN}$	Other than $V_{CC}$ , $V_{SS}$ , $AV_{CC}$ , $AV_{SS}$	$f = 1\text{ MHz}$	—	5	15	pF	

# MB89470 Series

## 4. AC Characteristics

### (1) Reset Timing

( $V_{CC} = 5.0\text{ V}$ ,  $AV_{SS} = V_{SS} = 0.0\text{ V}$ ,  $T_A = -40\text{ }^\circ\text{C}$  to  $+85\text{ }^\circ\text{C}$ )

Parameter	Symbol	Condition	Value		Unit	Remarks
			Min	Max		
$\overline{\text{RST}}$ "L" pulse width	$t_{\text{ZLZH}}$	—	48 $t_{\text{HCYL}}$	—	ns	

- Notes :
- $t_{\text{HCYL}}$  is the oscillation cycle ( $1/F_c$ ) to input to the X0 pin.
  - If the reset pulse applied to the external reset pin ( $\overline{\text{RST}}$ ) does not meet the specifications, it may cause malfunctions. Use caution so that the reset pulse less than the specifications will not be fed to the external reset pin ( $\overline{\text{RST}}$ ).

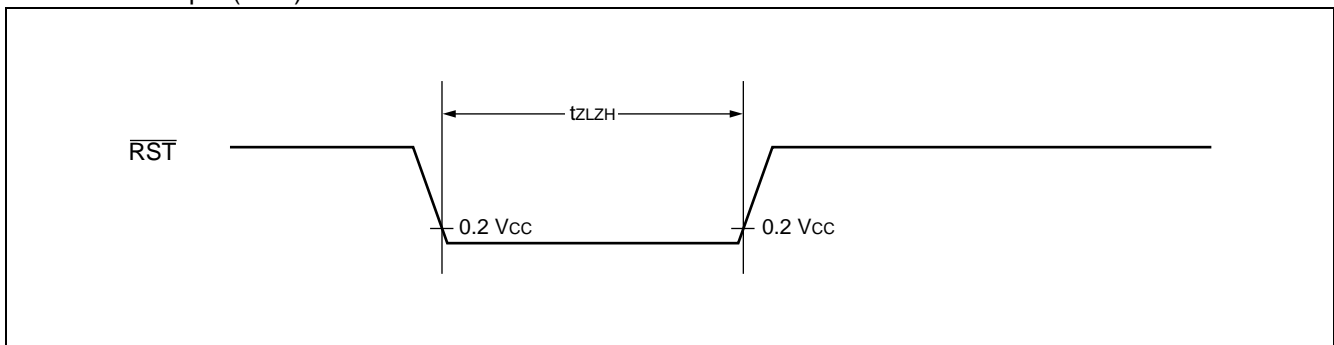

### (2) Power-on Reset

( $AV_{SS} = V_{SS} = 0.0\text{ V}$ ,  $T_A = -40\text{ }^\circ\text{C}$  to  $+85\text{ }^\circ\text{C}$ )

Parameter	Symbol	Condition	Value		Unit	Remarks
			Min	Max		
Power supply rising time	$t_r$	—	—	50	ms	
Power supply cut-off time	$t_{\text{OFF}}$	—	1	—	ms	Due to repeated operations

- Note :
- Make sure that power supply rises within the selected oscillation stabilization time.
  - Rapid changes in power supply voltage may cause a power-on reset. If power supply voltage needs to be varied in the course of operation, a smooth voltage rise is recommended.

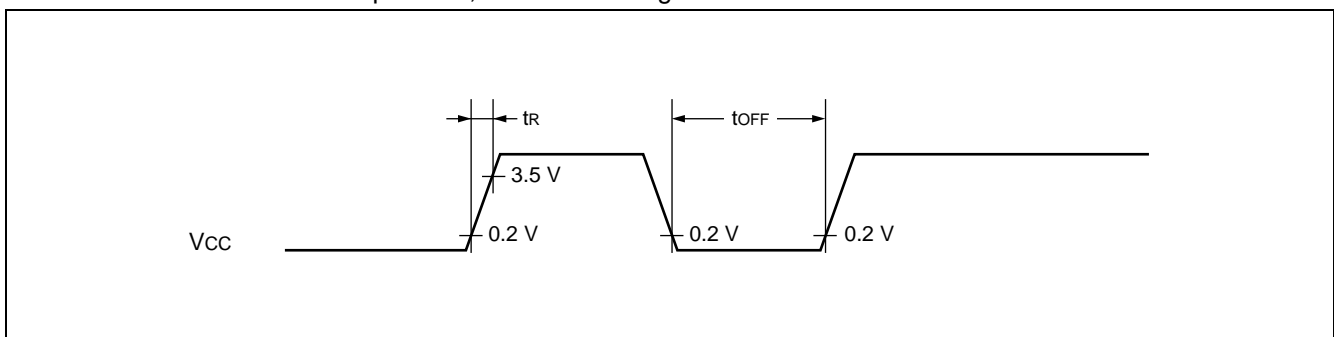

## (3) Clock Timing

( $V_{SS} = V_{SS} = 0.0\text{ V}$ ,  $T_A = -40\text{ }^\circ\text{C}$  to  $+85\text{ }^\circ\text{C}$ )

Parameter	Symbol	Pin	Value			Unit	Remarks
			Min	Typ	Max		
Clock frequency	$F_{CH}$	X0, X1	1	—	12.5	MHz	
	$F_{CL}$	X0A, X1A	—	32.768	—	kHz	
Clock cycle time	$t_{HCYL}$	X0, X1	80	—	1000	ns	
	$t_{LCYL}$	X0A, X1A	—	30.5	—	$\mu\text{s}$	
Input clock pulse width	$P_{WH}$ $P_{WL}$	X0	20	—	—	ns	External clock
	$P_{WHL}$ $P_{WLL}$	X0A	—	15.2	—	$\mu\text{s}$	
Input clock rising/falling time	$t_{CR}$ $t_{CF}$	X0, X0A	—	—	10	ns	

### X0 and X1 Timing and Conditions

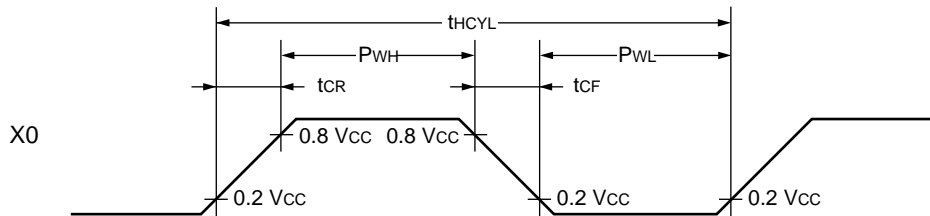

### Main Clock Conditions

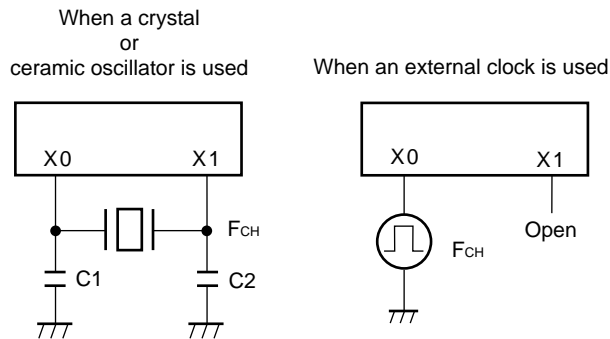

## Subclock Timing and Conditions

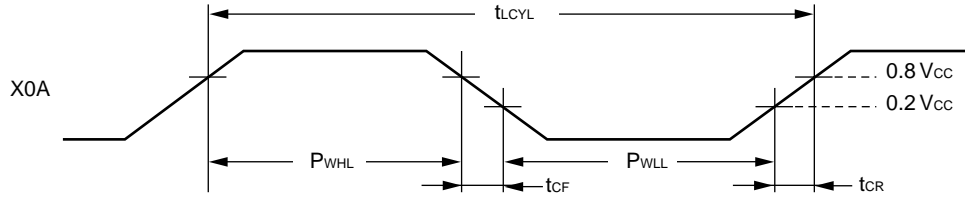

## Subclock Conditions

When a crystal or ceramic oscillator is used

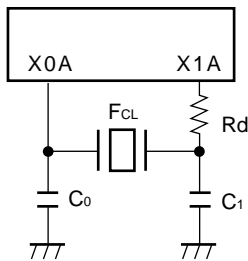

When an external clock is used

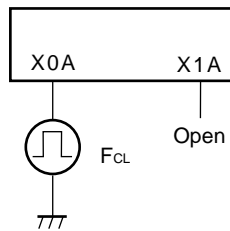

When sub-clock is not used in dual clock product

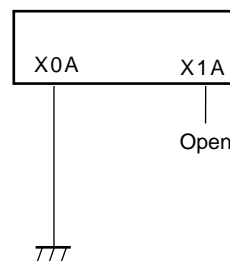

## (4) Instruction Cycle

Parameter	Symbol	Value	Unit	Remarks
Instruction cycle (minimum execution time)	t <sub>inst</sub>	4/F <sub>CH</sub> , 8/F <sub>CH</sub> , 16/F <sub>CH</sub> , 64/F <sub>CH</sub>	μs	(4/F <sub>CH</sub> ) t <sub>inst</sub> = 0.32 μs when operating at F <sub>CH</sub> = 12.5 MHz
		2/F <sub>CL</sub>	μs	t <sub>inst</sub> = 61.036 μs when operating at F <sub>CL</sub> = 32.768 kHz

## (5) Serial I/O Timing

( $V_{CC} = 5.0\text{ V}$ ,  $AV_{SS} = V_{SS} = 0.0\text{ V}$ ,  $T_A = -40\text{ }^\circ\text{C}$  to  $+85\text{ }^\circ\text{C}$ )

Parameter	Symbol	Pin	Condition	Value		Unit
				Min	Max	
Serial clock cycle time	$t_{SCYC}$	SCK1, SCK2	Internal shift clock mode	$2 t_{inst}^*$	—	$\mu\text{s}$
SCK $\downarrow$ $\rightarrow$ SO time	$t_{SLOV}$	SCK1, SO1, SCK2, SO2		-200	+200	ns
Valid SI $\rightarrow$ SCK $\uparrow$	$t_{IVSH}$	SI1, SCK1, SI2, SCK2		$1/2 t_{inst}^*$	—	ns
SCK $\uparrow$ $\rightarrow$ valid SI hold time	$t_{SHIX}$	SCK1, SI1, SCK2, SI2		$1/2 t_{inst}^*$	—	ns
Serial clock "H" pulse width	$t_{SHSL}$	SCK1, SCK2	External shift clock mode	$1 t_{inst}^*$	—	$\mu\text{s}$
Serial clock "L" pulse width	$t_{LSLH}$			$1 t_{inst}^*$	—	$\mu\text{s}$
SCK $\downarrow$ $\rightarrow$ SO time	$t_{SLOV}$	SCK1, SO1, SCK2, SO2		0	200	ns
Valid SI $\rightarrow$ SCK $\uparrow$	$t_{IVSH}$	SI1, SCK1, SI2, SCK2		$1/2 t_{inst}^*$	—	ns
SCK $\uparrow$ $\rightarrow$ valid SI hold time	$t_{SHIX}$	SCK1, SI1, SCK2, SI2		$1/2 t_{inst}^*$	—	ns

\* : For information on  $t_{inst}$ , see "(4) Instruction Cycle."

### Internal Clock Operation

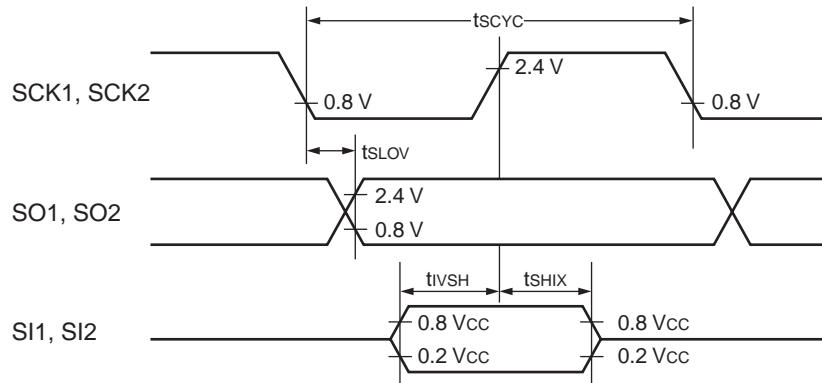

### External Clock Operation

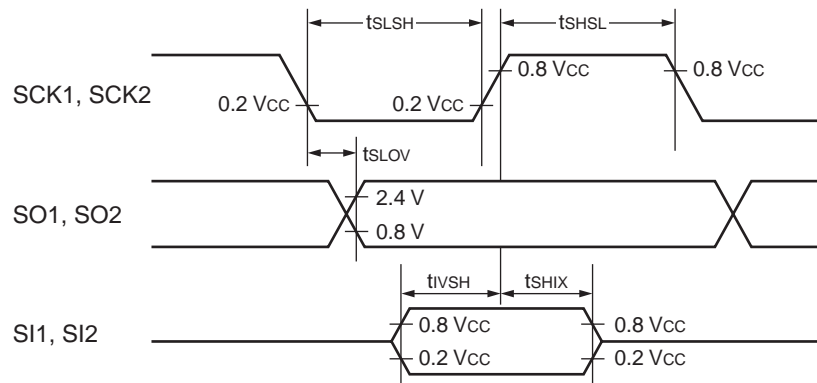

# MB89470 Series

## (6) Peripheral Input Timing

( $A_{V_{CC}} = V_{CC} = 5.0\text{ V}$ ,  $A_{V_{SS}} = V_{SS} = 0.0\text{ V}$ ,  $T_A = -40\text{ }^{\circ}\text{C}$  to  $+85\text{ }^{\circ}\text{C}$ )

Parameter	Symbol	Pin	Value		Unit	Remarks
			Min	Max		
Peripheral input "H" pulse width 1	$t_{ILIH1}$	INT10 to INT13, INT20 to INT24, EC1, EC2, PWC	$2 t_{inst}^*$	—	$\mu\text{s}$	
Peripheral input "L" pulse width 1	$t_{IHIL1}$		$2 t_{inst}^*$	—	$\mu\text{s}$	

\* : For information on  $t_{inst}$ , see "(4) Instruction Cycle."

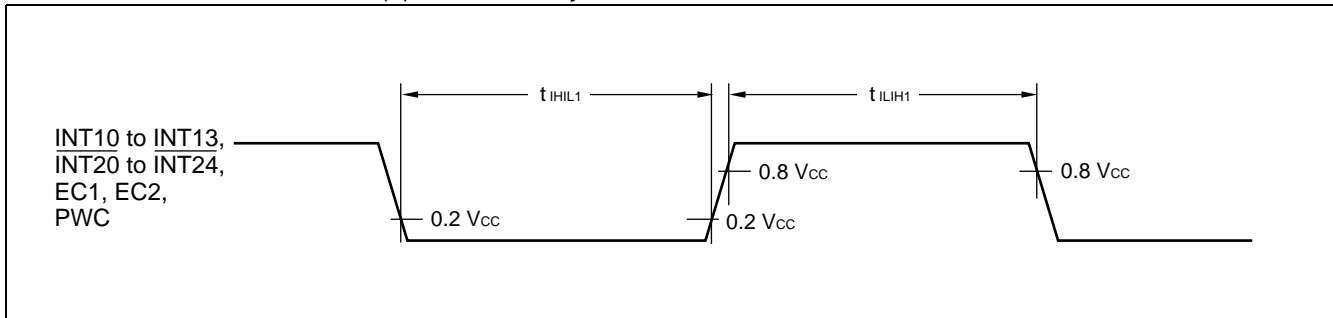

## 5. A/D Converter Electrical Characteristics

### (1) A/D Converter Electrical Characteristics

( $V_{CC} = V_{CC} = 4.5 \text{ V to } 5.5 \text{ V}$ ,  $V_{SS} = V_{SS} = 0.0 \text{ V}$ ,  $T_A = -40 \text{ }^\circ\text{C to } +85 \text{ }^\circ\text{C}$ )

Parameter	Symbol	Pin	Value			Unit	Remarks
			Min	Typ	Max		
Resolution	—	—	—	10	—	bit	
Total error			—	—	$\pm 4.0$	LSB	
Linearity error			—	—	$\pm 2.5$	LSB	
Differential linearity error			—	—	$\pm 1.9$	LSB	
Zero transition voltage	$V_{OT}$	—	$AV_{SS} - 1.5 \text{ LSB}$	$AV_{SS} + 0.5 \text{ LSB}$	$AV_{SS} + 2.5 \text{ LSB}$	V	
Full-scale transition voltage	$V_{FST}$		$AV_{CC} - 4.5 \text{ LSB}$	$AV_{CC} - 2.5 \text{ LSB}$	$AV_{CC} - 0.5 \text{ LSB}$	V	
A/D mode conversion time	—		—	—	$60 t_{inst}^*$	$\mu\text{s}$	
Analog port input current	$I_{AIN}$	AN0 to	—	—	10	$\mu\text{A}$	
Analog input voltage	$V_{AIN}$	AN7	$AV_{SS}$	—	$AV_{CC}$	V	

\* : For information on  $t_{inst}$ , see “(4) Instruction Cycle” in “4. AC Characteristics”.

### (2) A/D Converter Glossary

- Resolution  
Analog changes that are identifiable with the A/D converter  
When the number of bits is 10, analog voltage can be divided into  $2^{10} = 1024$ .
- Linearity error (unit : LSB)  
The deviation of the straight line connecting the zero transition point (“00 0000 0000”  $\leftrightarrow$  “00 0000 0001”) with the full-scale transition point (“11 1111 1111”  $\leftrightarrow$  “11 1111 1110”) from actual conversion characteristics.
- Differential linearity error (unit : LSB)  
The deviation of input voltage needed to change the output code by 1 LSB from the theoretical value.
- Total error (unit : LSB)  
The difference between theoretical and actual conversion values.

Theoretical I/O characteristics

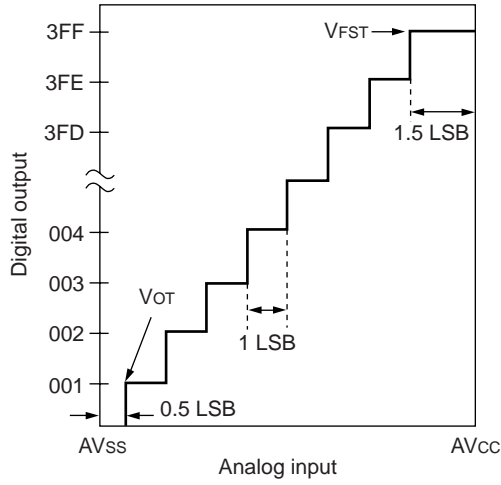

$$1 \text{ LSB} = \frac{V_{FST} - V_{OT}}{1022} \text{ (V)}$$

Total error

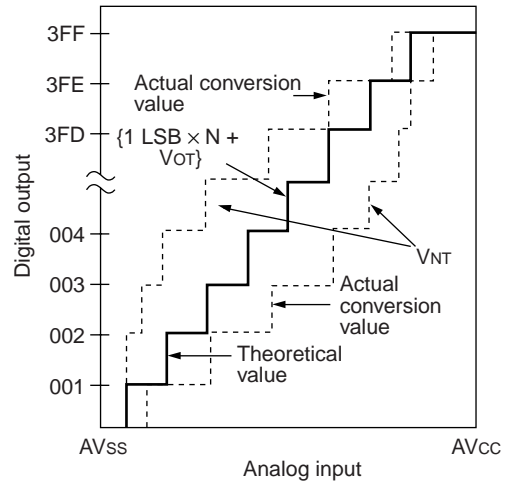

$$\text{Total error} = \frac{V_{NT} - \{1 \text{ LSB} \times N + 0.5 \text{ LSB}\}}{1 \text{ LSB}}$$

Zero transition error

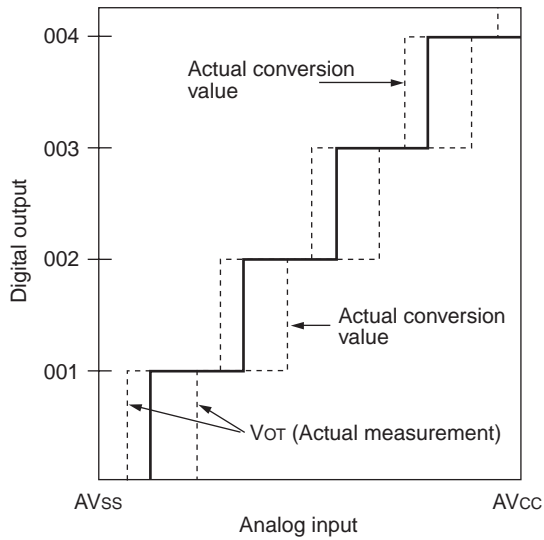

Full-scale transition error

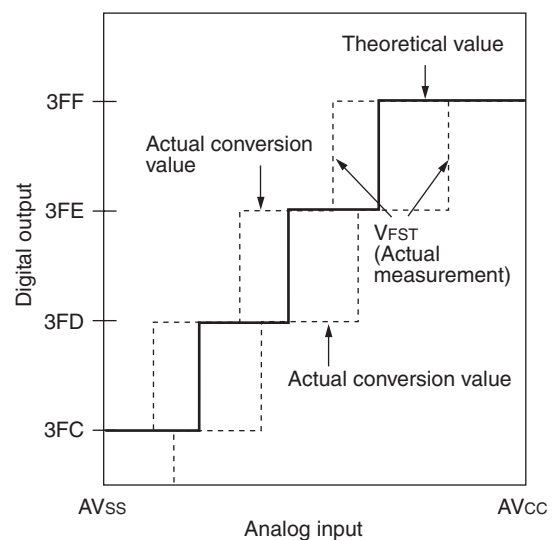

(Continued)

(Continued)

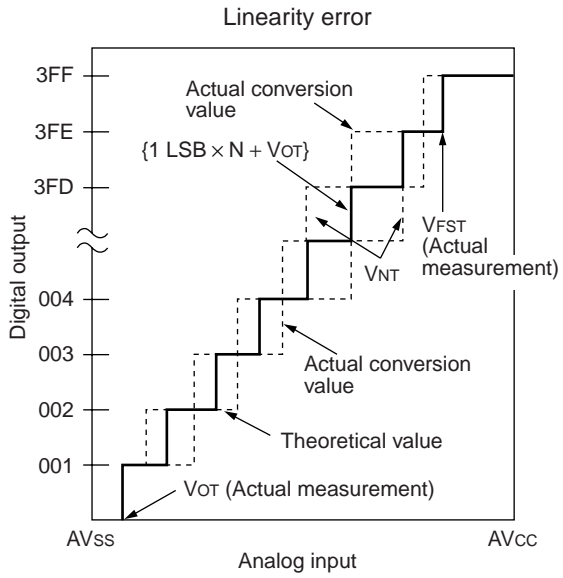

$$\text{Linearity error} = \frac{V_{NT} - \{1 \text{ LSB} \times N + V_{OT}\}}{1 \text{ LSB}}$$

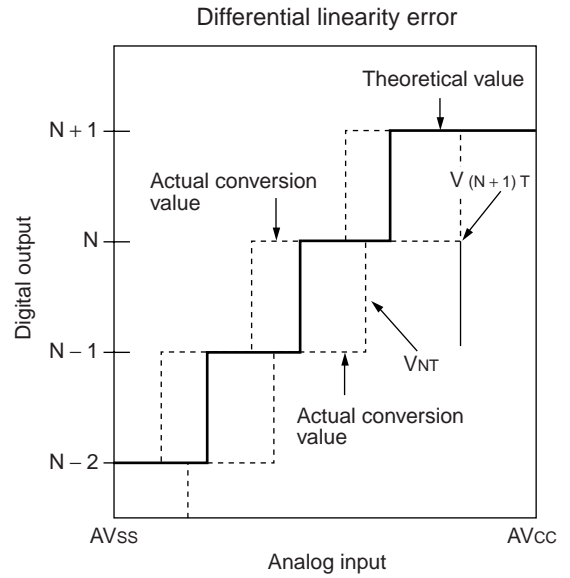

$$\text{Differential linearity error} = \frac{V_{(N+1)T} - V_{NT}}{1 \text{ LSB}} - 1$$

# MB89470 Series

### (3) Notes on Using A/D Converter

- Input impedance of the analog input pins

The A/D converter used for the MB89470 series contains a sample & hold circuit as illustrated below to fetch analog input voltage into the sample & hold capacitor for 16 instruction cycles after activation A/D conversion.

For this reason, if the output impedance of the external circuit for the analog input is high, analog input voltage might not stabilize within the analog input sampling period. Therefore, it is recommended to keep the output impedance of the external circuit low.

Note that if the impedance cannot be kept low, it is recommended to connect an external capacitor of about 0.1  $\mu\text{F}$  for the analog input pin.

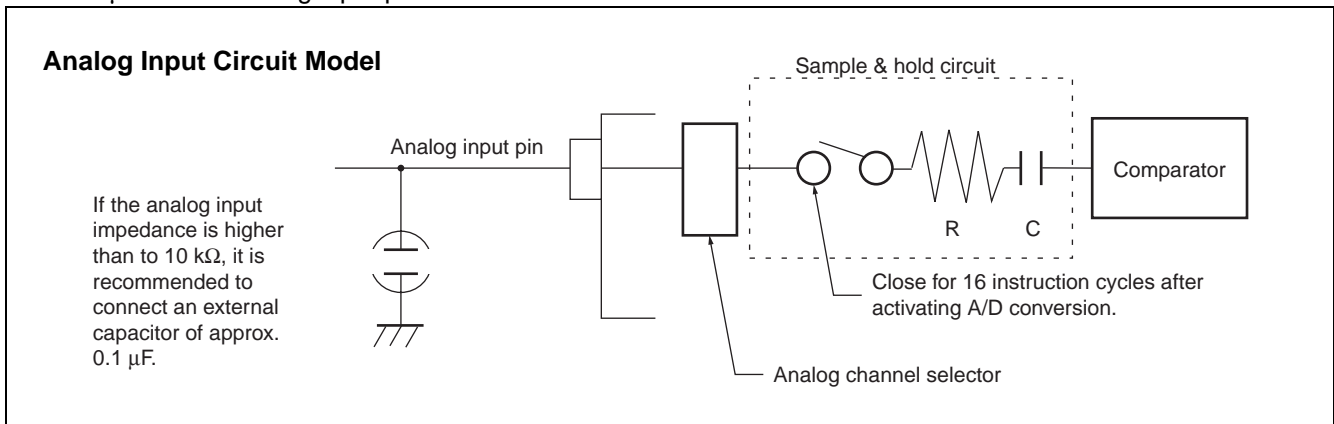

Sample & hold circuit	MB89475 MB89PV470	MB89P475
R : analog input equivalent resistance	2.2 k $\Omega$	2.6 k $\Omega$
C : analog input equivalent capacitance	45 pF	28 pF

## EXAMPLE CHARACTERISTICS

- “L” level output voltage

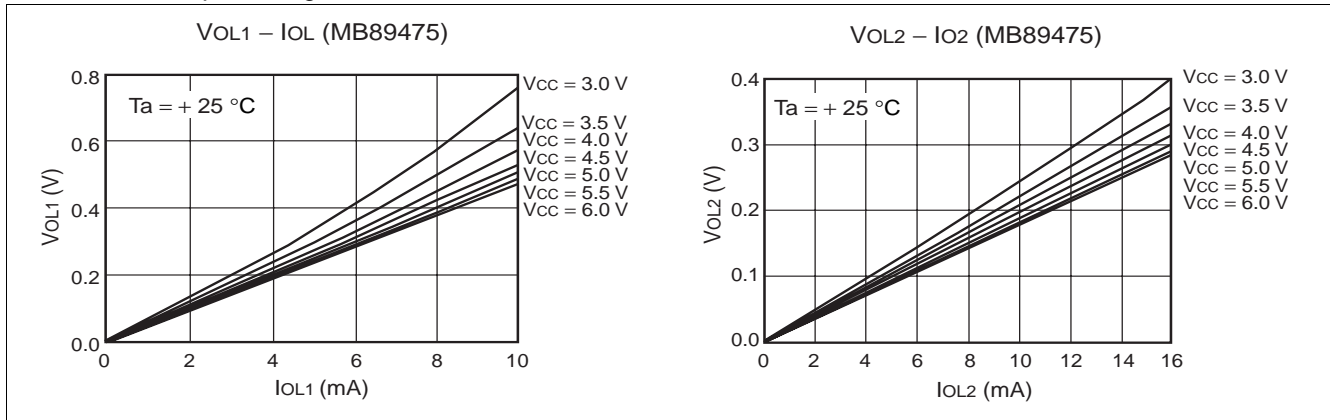

- “H” level output voltage

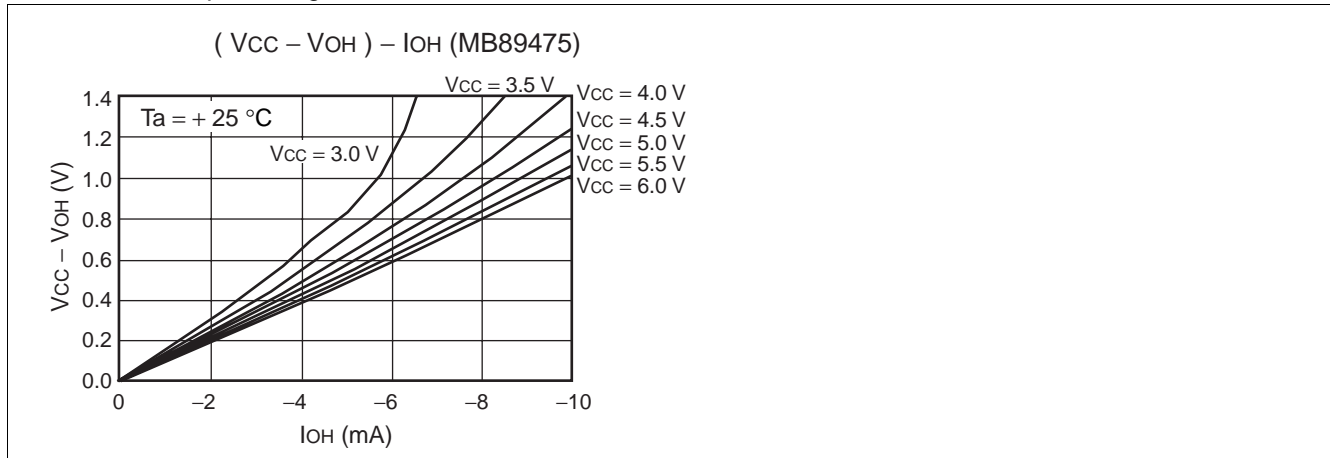

- “H” level input voltage/“L” level input voltage

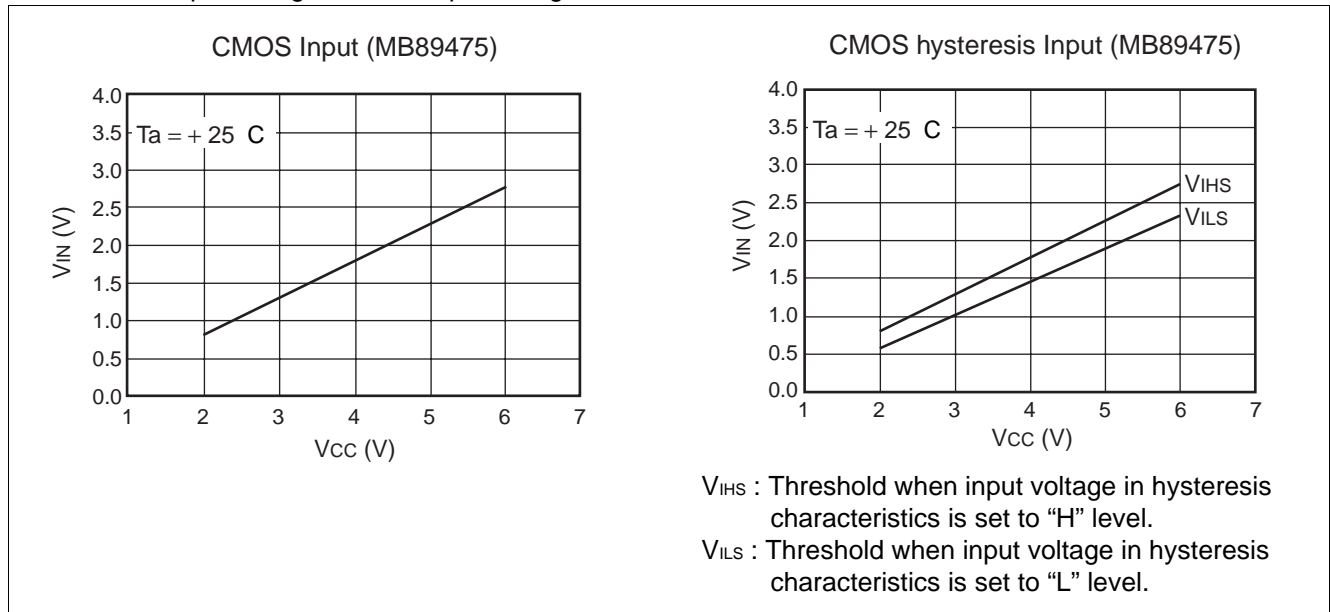

# MB89470 Series

- Power supply current (External clock)

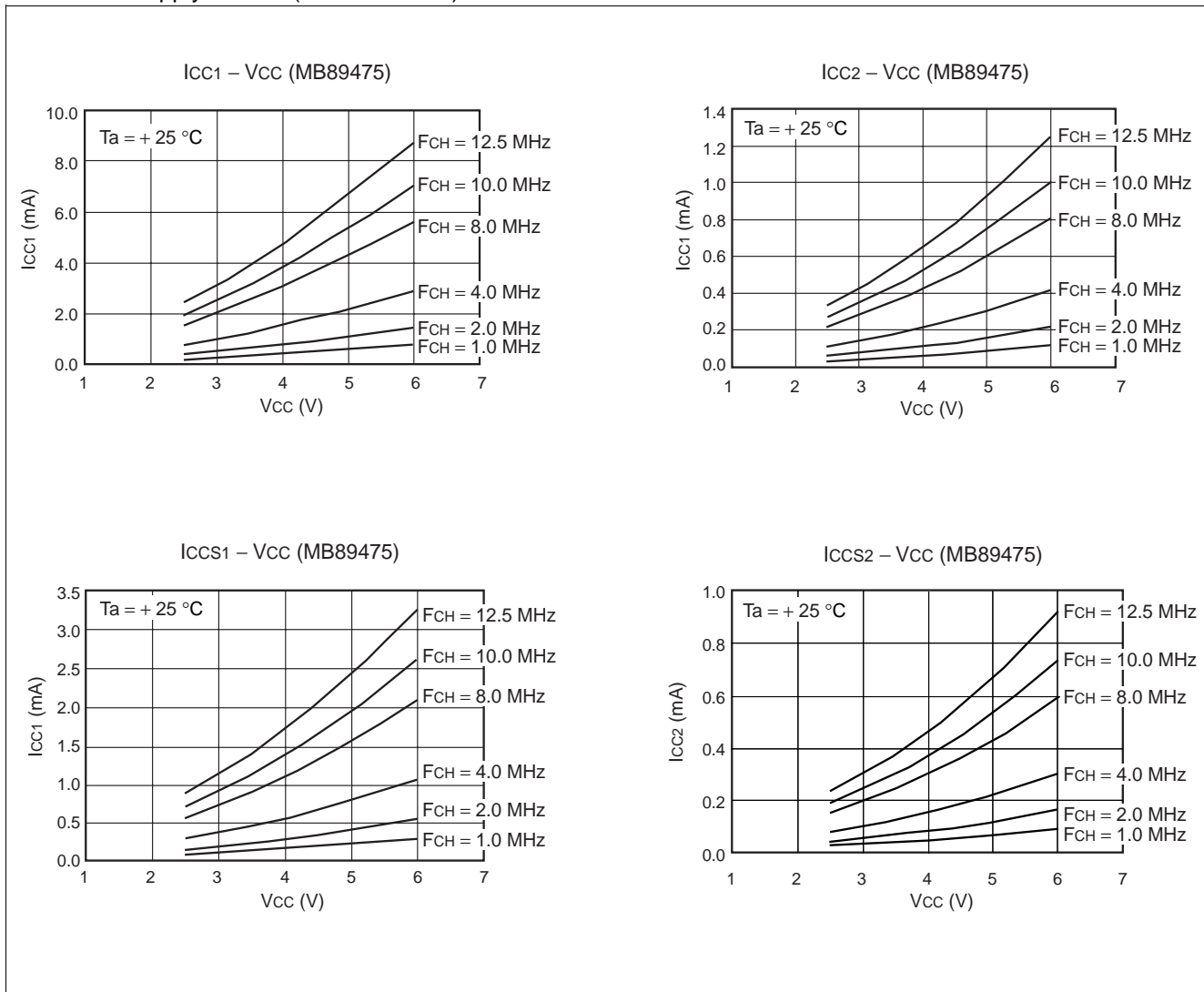

(Continued)

(Continued)

I<sub>CCL</sub> – V<sub>CC</sub> (MB89475)

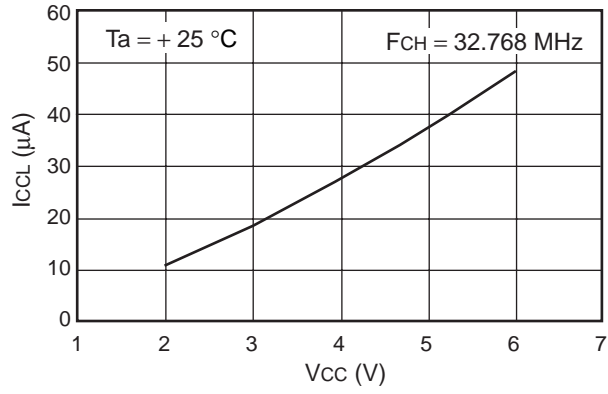

I<sub>CCLS</sub> – V<sub>CC</sub> (MB89475)

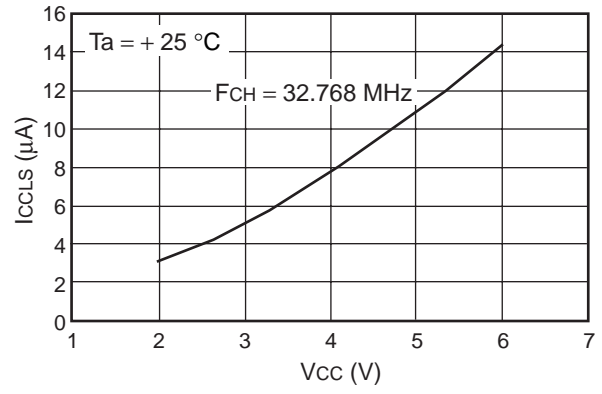

I<sub>CCT</sub> – V<sub>CC</sub> (MB89475)

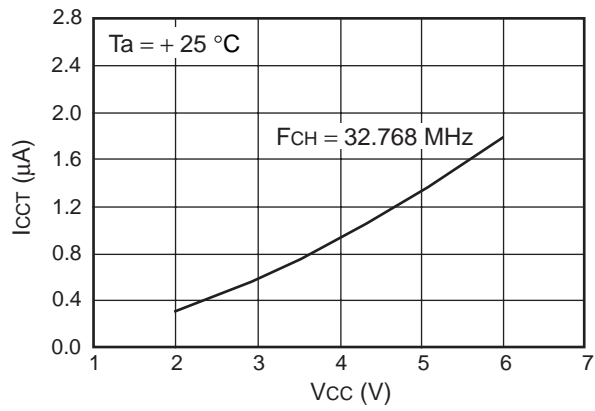

# MB89470 Series

- Pull-up resistance

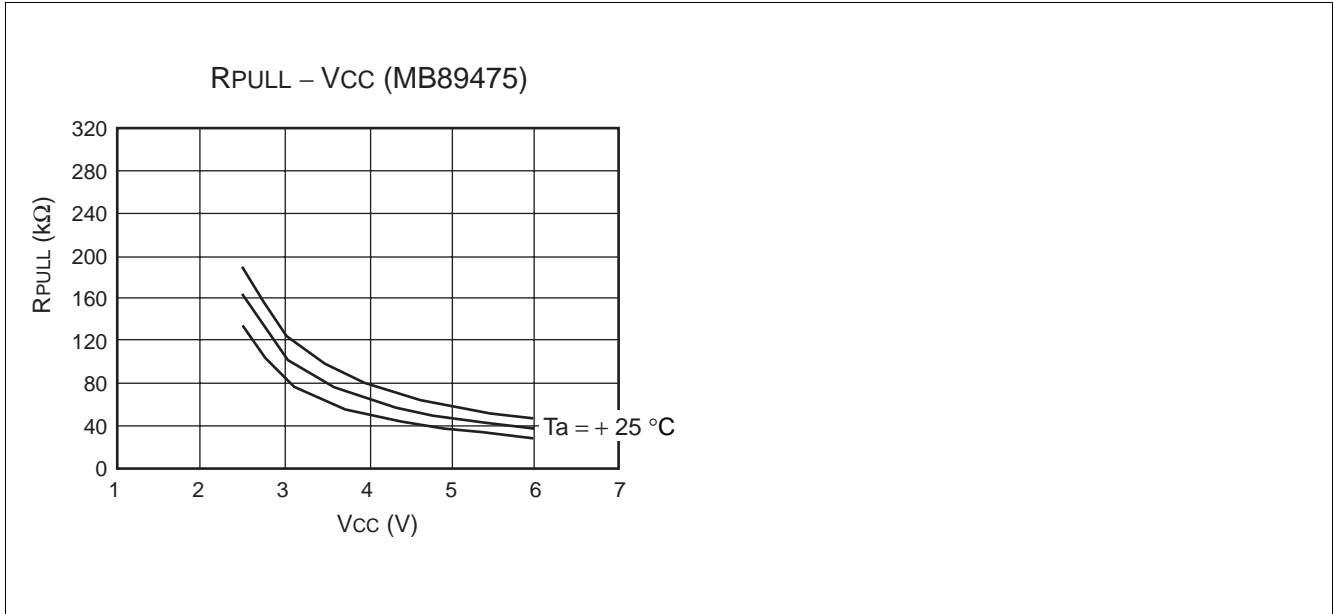

## ■ MASK OPTIONS

No.	Part number	MB89475	MB89P475	MB89PV470
	Specifying procedure	Specify when ordering mask	Setting not possible	Setting not possible
1	Selection of clock mode <ul style="list-style-type: none"> <li>• Single clock mode</li> <li>• Dual clock mode</li> </ul>	Selectable	101/102 : Single clock 201/202 : Dual clock	101 : Single clock 201 : Dual clock
2	Selection of oscillation stabilization time (OSC) <ul style="list-style-type: none"> <li>• The initial value of the oscillation stabilization time for the main clock can be set by selecting the values of the WTM1 and WTM0 bits on the right.</li> </ul>	Selectable OSC 1 : $2^{14}/F_{CH}$ 2 : $2^{17}/F_{CH}$ 3 : $2^{18}/F_{CH}$	Fixed to oscillation stabilization time of $2^{18}/F_{CH}$	Fixed to oscillation stabilization time of $2^{18}/F_{CH}$
3	Selection of power-on stabilization time <ul style="list-style-type: none"> <li>• Nil</li> <li>• <math>2^{17}/F_{CH}</math></li> </ul>	Selectable	Fixed to power-on stabilization time of $2^{17}/F_{CH}$	Fixed to nil

## ■ ORDERING INFORMATION

Part number	Package	Remarks
MB89475PFM MB89P475-101PFM MB89P475-102PFM MB89P475-201PFM MB89P475-202PFM	48-pin Plastic QFP (FPT-48P-M13)	101 : Single clock, without content protection 102 : Single clock, with content protection 201 : Dual clock, without content protection 202 : Dual clock, with content protection
MB89475PMC MB89P475-101PMC MB89P475-102PMC MB89P475-201PMC MB89P475-202PMC	48-pin Plastic LQFP (FPT-48P-M26)	
MB89475P-SH MB89P475-101P-SH MB89P475-102P-SH MB89P475-201P-SH MB89P475-202P-SH	48-pin Plastic SH-DIP (DIP-48P-M01)	
MB89PV470-101CF MB89PV470-201CF	48-pin Ceramic MQFP (MQP-48C-P01)	

# MB89470 Series

## ■ PACKAGE DIMENSIONS

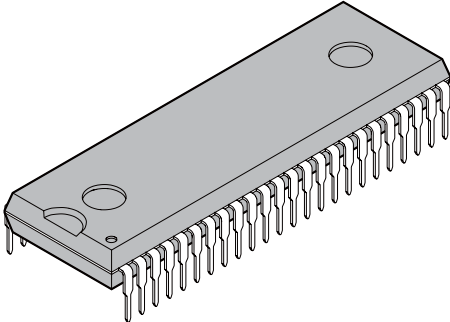
<p>48-pin plastic SH-DIP</p>  <p>(DIP-48P-M01)</p>	Lead pitch	1.778mm(70mil)
	Row spacing	15.24mm(600mil)
	Sealing method	Plastic mold

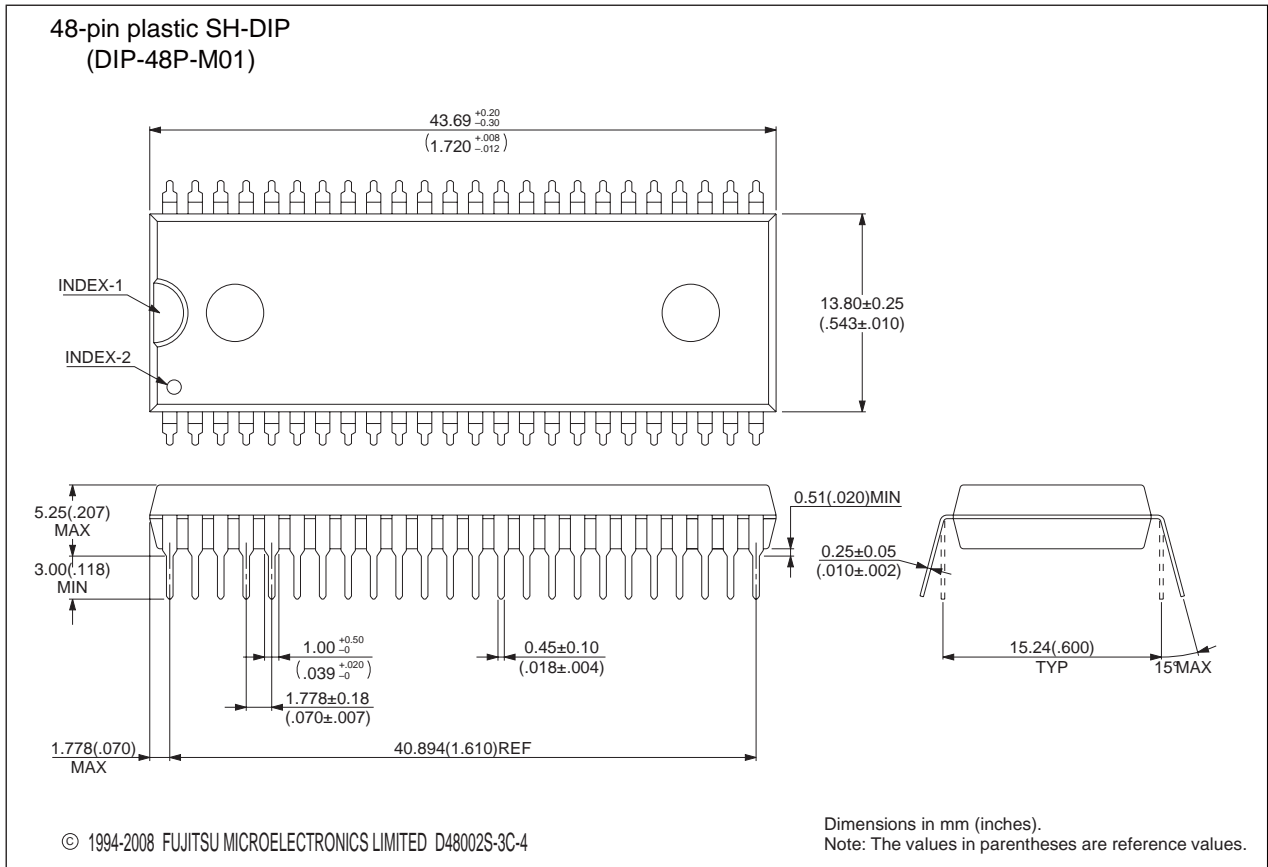

Please confirm the latest Package dimension by following URL.  
<http://edevic.fujitsu.com/package/en-search/>

(Continued)

# MB89470 Series

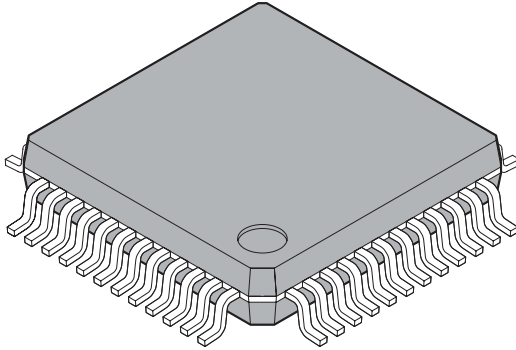
<p>48-pin plastic LQFP</p>  <p>(FPT-48P-M26)</p>	Lead pitch	0.50 mm
	Package width × package length	7 × 7 mm
	Lead shape	Gullwing
	Sealing method	Plastic mold
	Mounting height	1.70 mm MAX
	Weight	0.17 g
	Code (Reference)	P-LFQFP48-7×7-0.50

48-pin plastic LQFP (FPT-48P-M26)

Note 1) \* : These dimensions include resin protrusion.  
 Note 2) Pins width and pins thickness include plating thickness.  
 Note 3) Pins width do not include tie bar cutting remainder.

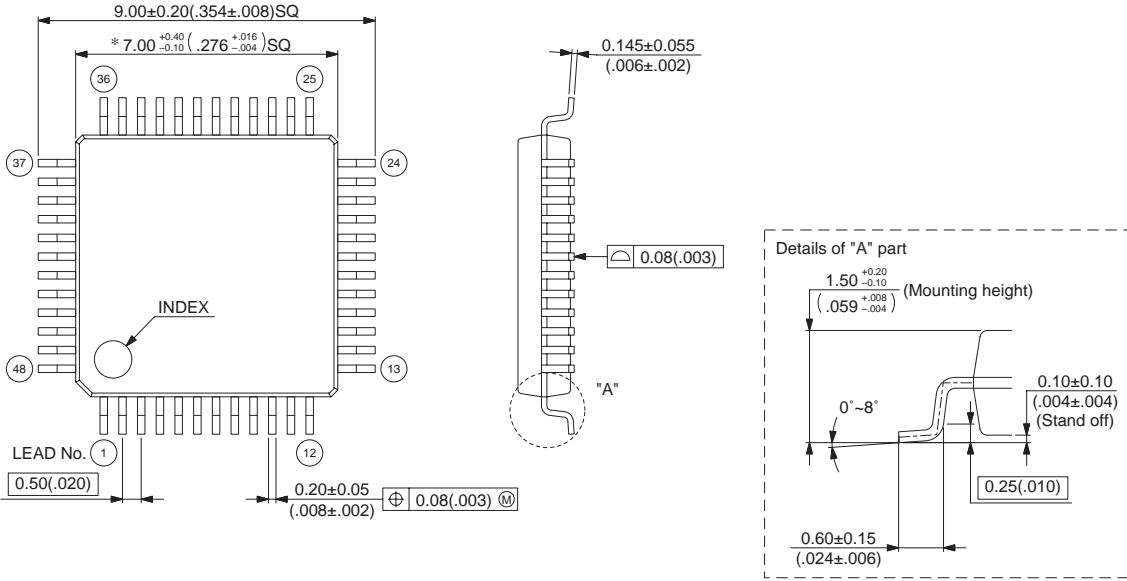

©2003-2008 FUJITSU MICROELECTRONICS LIMITED F48040S-c-2-3

Dimensions in mm (inches).  
 Note: The values in parentheses are reference values.

Please confirm the latest Package dimension by following URL.  
<http://edevice.fujitsu.com/package/en-search/>

(Continued)

# MB89470 Series

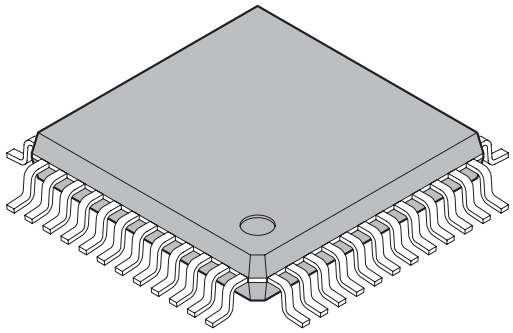
<p style="text-align: center;">48-pin plastic QFP</p>  <p style="text-align: center;">(FPT-48P-M13)</p>	Lead pitch	0.80 mm
	Package width × package length	10 × 10 mm
	Lead shape	Gullwing
	Sealing method	Plastic mold
	Mounting height	2.35 mm MAX
	Code (Reference)	P-QFP44-10×10-0.80

48-pin plastic QFP (FPT-48P-M13)

Note 1) \* : These dimensions do not include resin protrusion.  
 Note 2) Pins width and pins thickness include plating thickness.  
 Note 3) Pins width do not include tie bar cutting remainder.

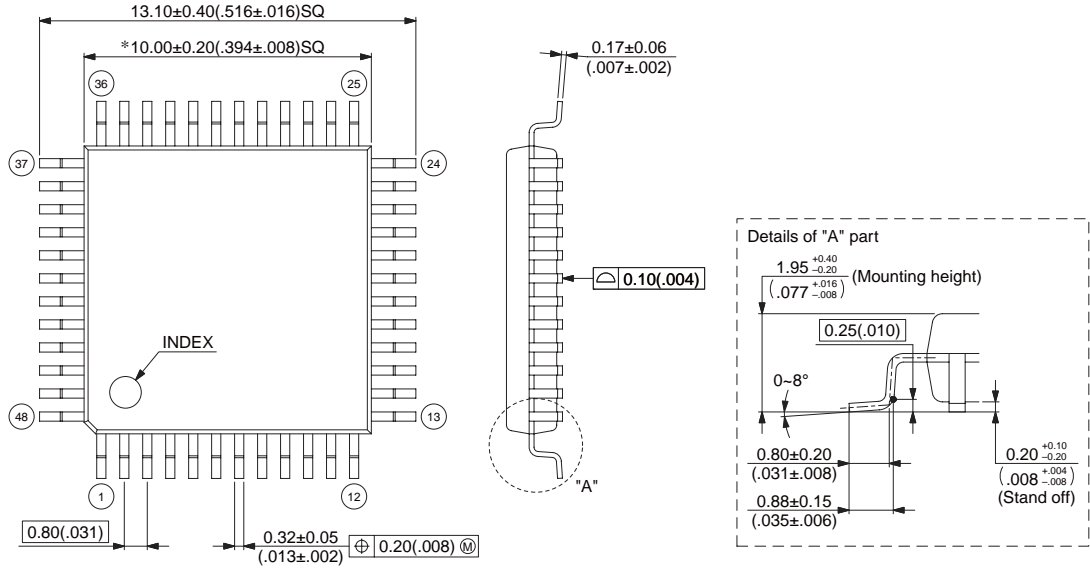

Top view dimensions:  
 Overall width:  $13.10 \pm 0.40$  (.516 ± .016) SQ  
 Pin pitch:  $0.80$  (.031)  
 Pin width:  $0.32 \pm 0.05$  (.013 ± .002)  $\oplus 0.20$  (.008)  $\text{M}$   
 Pin thickness:  $0.17 \pm 0.06$  (.007 ± .002)  
 Stand off:  $0.20$   $\begin{smallmatrix} +0.10 \\ -0.20 \\ (.008 \text{ } -0.008) \end{smallmatrix}$

Side view dimensions:  
 Mounting height:  $1.95$   $\begin{smallmatrix} +0.40 \\ -0.20 \\ (.077 \text{ } -0.008) \end{smallmatrix}$   
 Lead thickness:  $0.10$  (.004)  
 Lead width:  $0.25$  (.010)  
 Lead angle: 0~8°  
 Pin width:  $0.80 \pm 0.20$  (.031 ± .008)  
 Pin thickness:  $0.88 \pm 0.15$  (.035 ± .006)

Details of "A" part:  
 Mounting height:  $1.95$   $\begin{smallmatrix} +0.40 \\ -0.20 \\ (.077 \text{ } -0.008) \end{smallmatrix}$   
 Lead thickness:  $0.10$  (.004)  
 Lead width:  $0.25$  (.010)  
 Lead angle: 0~8°  
 Pin width:  $0.80 \pm 0.20$  (.031 ± .008)  
 Pin thickness:  $0.88 \pm 0.15$  (.035 ± .006)  
 Stand off:  $0.20$   $\begin{smallmatrix} +0.10 \\ -0.20 \\ (.008 \text{ } -0.008) \end{smallmatrix}$

© 2003-2008 FUJITSU MICROELECTRONICS LIMITED F48023S-c-3-5

Dimensions in mm (inches).  
 Note: The values in parentheses are reference values.

Please confirm the latest Package dimension by following URL.  
<http://edevice.fujitsu.com/package/en-search/>

(Continued)

# MB89470 Series

(Continued)

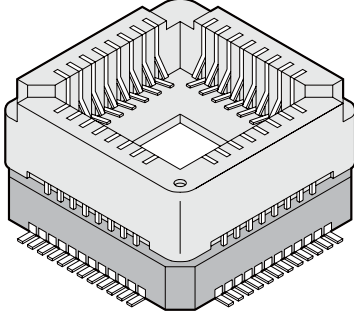
<p style="text-align: center;">48-pin ceramic MQFP</p>  <p style="text-align: center;">(MQP-48C-P01)</p>	Lead pitch	0.8 mm	
	Lead shape	Straight	
	Motherboard material	Ceramic	
	Mounted package material	Plastic	

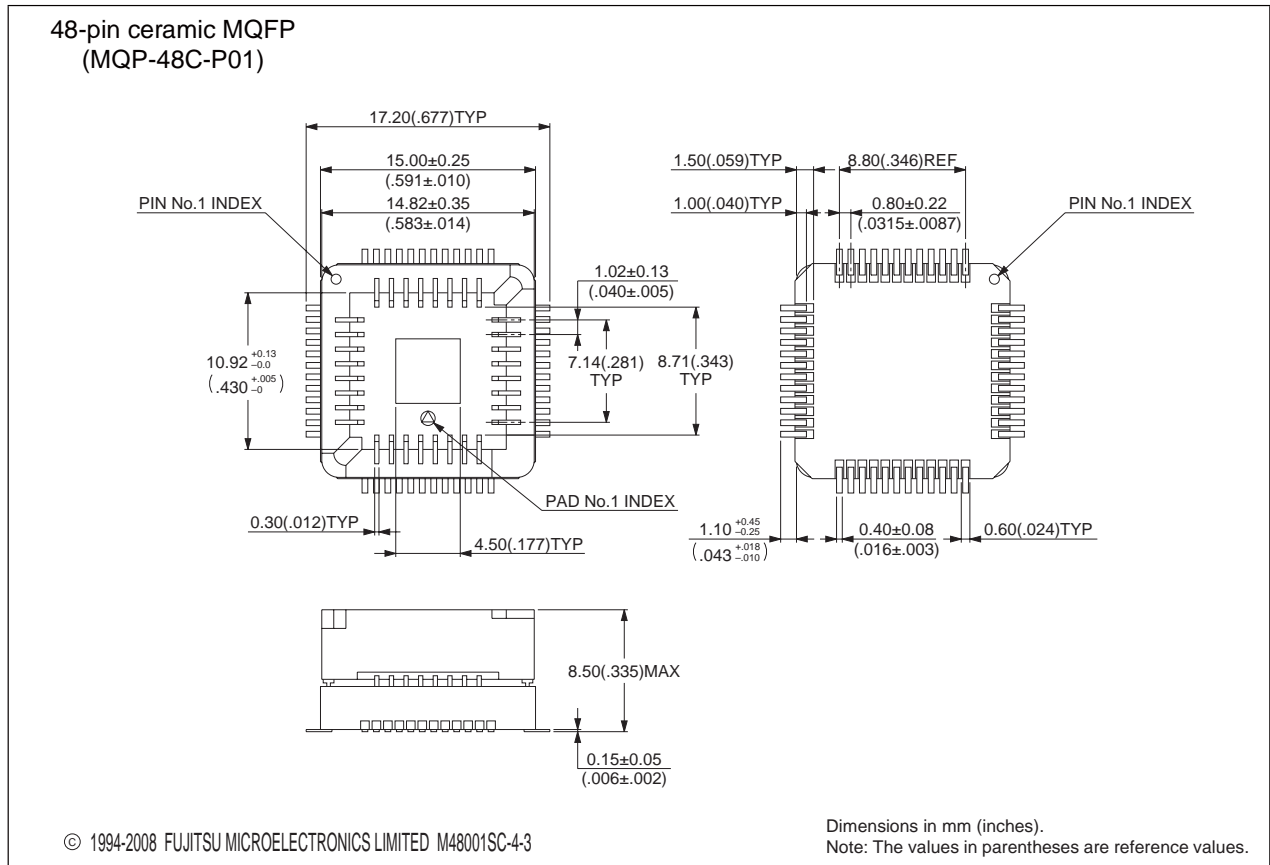

Please confirm the latest Package dimension by following URL.  
<http://edevice.fujitsu.com/package/en-search/>

# MB89470 Series

## ■ MAIN CHANGES IN THIS EDITION

Page	Section	Change Results
—	—	Changed the package code. FPT-48P-M05 → FPT-48P-M26
15	■ PROGRAMMING OTPROM IN MB89P475 WITH PROGRAMMER	Changed the "2. ROM Writer Adapters and Recommended ROM Writers".
16	■ PROGRAMMING TO THE EPROM WITH PIGGYBACK/EVALUATION DEVICE	Deleted the "2. Programming Socket Adapter"
43	■ ORDERING INFORMATION	Order informations are changed. MB89475PFV → MB89475PMC MB89P475-101PFV → MB89P475-101PMC MB89P475-102PFV → MB89P475-102PMC MB89P475-201PFV → MB89P475-201PMC MB89P475-202PFV → MB89P475-202PMC
45	■ PACKAGE DIMENSIONS	Changed the package figure. FPT-48P-M05 → FPT-48P-M26

The vertical lines marked in the left side of the page show the changes.

**MEMO**

**MEMO**

**MEMO**

# MB89470 Series

## FUJITSU MICROELECTRONICS LIMITED

Shinjuku Dai-Ichi Seimei Bldg., 7-1, Nishishinjuku 2-chome,  
Shinjuku-ku, Tokyo 163-0722, Japan  
Tel: +81-3-5322-3347 Fax: +81-3-5322-3387  
<http://jp.fujitsu.com/fml/en/>

*For further information please contact:*

### North and South America

FUJITSU MICROELECTRONICS AMERICA, INC.  
1250 E. Arques Avenue, M/S 333  
Sunnyvale, CA 94085-5401, U.S.A.  
Tel: +1-408-737-5600 Fax: +1-408-737-5999  
<http://www.fma.fujitsu.com/>

### Asia Pacific

FUJITSU MICROELECTRONICS ASIA PTE. LTD.  
151 Lorong Chuan,  
#05-08 New Tech Park 556741 Singapore  
Tel : +65-6281-0770 Fax : +65-6281-0220  
<http://www.fmal.fujitsu.com/>

### Europe

FUJITSU MICROELECTRONICS EUROPE GmbH  
Pittlerstrasse 47, 63225 Langen, Germany  
Tel: +49-6103-690-0 Fax: +49-6103-690-122  
<http://emea.fujitsu.com/microelectronics/>

### FUJITSU MICROELECTRONICS SHANGHAI CO., LTD.

Rm. 3102, Bund Center, No.222 Yan An Road (E),  
Shanghai 200002, China  
Tel : +86-21-6146-3688 Fax : +86-21-6335-1605  
<http://cn.fujitsu.com/fmc/>

### Korea

FUJITSU MICROELECTRONICS KOREA LTD.  
206 Kosmo Tower Building, 1002 Daechi-Dong,  
Gangnam-Gu, Seoul 135-280, Republic of Korea  
Tel: +82-2-3484-7100 Fax: +82-2-3484-7111  
<http://kr.fujitsu.com/fmk/>

### FUJITSU MICROELECTRONICS PACIFIC ASIA LTD.

10/F., World Commerce Centre, 11 Canton Road,  
Tsimshatsui, Kowloon, Hong Kong  
Tel : +852-2377-0226 Fax : +852-2376-3269  
<http://cn.fujitsu.com/fmc/en/>

Specifications are subject to change without notice. For further information please contact each office.

### All Rights Reserved.

The contents of this document are subject to change without notice.

Customers are advised to consult with sales representatives before ordering.

The information, such as descriptions of function and application circuit examples, in this document are presented solely for the purpose of reference to show examples of operations and uses of FUJITSU MICROELECTRONICS device; FUJITSU MICROELECTRONICS does not warrant proper operation of the device with respect to use based on such information. When you develop equipment incorporating the device based on such information, you must assume any responsibility arising out of such use of the information.

FUJITSU MICROELECTRONICS assumes no liability for any damages whatsoever arising out of the use of the information.

Any information in this document, including descriptions of function and schematic diagrams, shall not be construed as license of the use or exercise of any intellectual property right, such as patent right or copyright, or any other right of FUJITSU MICROELECTRONICS or any third party or does FUJITSU MICROELECTRONICS warrant non-infringement of any third-party's intellectual property right or other right by using such information. FUJITSU MICROELECTRONICS assumes no liability for any infringement of the intellectual property rights or other rights of third parties which would result from the use of information contained herein.

The products described in this document are designed, developed and manufactured as contemplated for general use, including without limitation, ordinary industrial use, general office use, personal use, and household use, but are not designed, developed and manufactured as contemplated (1) for use accompanying fatal risks or dangers that, unless extremely high safety is secured, could have a serious effect to the public, and could lead directly to death, personal injury, severe physical damage or other loss (i.e., nuclear reaction control in nuclear facility, aircraft flight control, air traffic control, mass transport control, medical life support system, missile launch control in weapon system), or (2) for use requiring extremely high reliability (i.e., submersible repeater and artificial satellite).

Please note that FUJITSU MICROELECTRONICS will not be liable against you and/or any third party for any claims or damages arising in connection with above-mentioned uses of the products.

Any semiconductor devices have an inherent chance of failure. You must protect against injury, damage or loss from such failures by incorporating safety design measures into your facility and equipment such as redundancy, fire protection, and prevention of over-current levels and other abnormal operating conditions.

Exportation/release of any products described in this document may require necessary procedures in accordance with the regulations of the Foreign Exchange and Foreign Trade Control Law of Japan and/or US export control laws.

The company names and brand names herein are the trademarks or registered trademarks of their respective owners.

Edited: Business & Media Promotion Dept.