

## *8-bit Proprietary Microcontroller*

CMOS

# F<sup>2</sup>MC-8L MB89940 Series

## MB89943/945/P945/PV940

### ■ DESCRIPTION

The MB89940 series is specially designed for automotive instrumentation applications. It features a combination of two PWM pulse generators and four high-drive-current outputs for controlling a stepping motor. It also contains two analog inputs, two PWM pulse generators and 10-digit LCD controller/driver for various sensor/indicator devices. The MB89940 series is manufactured with high performance CMOS technologies and packaged in a 48-pin QFP.

### ■ FEATURES

- 8-bit core CPU: 4 MHz system clock (8 MHz external, 500 ns instruction cycle)
- 21-bit timebase timer
- Watchdog timer
- Clock generator/controller
- 16-bit interval timer
- Two PWM pulse generators with four high-drive-current outputs
- Two-channel 8-bit A/D converter
- Three external interrupt
- Low supply voltage reset
- External voltage monitor interrupt
- Two more PWM pulse generators for controlling indicator devices
- 4-common 17-segment LCD driver/controller
- Package: 48-pin plastic QFP, 48-pin ceramic MQFP
- 5.0 V single power supply ( $V_{PP}$  required for MB89P945)
- On-chip voltage regulator for internal 3.0 V power supply (MB89943, MB89945)

For the information for microcontroller supports, see the following web site.

<http://edevice.fujitsu.com/micom/en-support/>

# MB89940 Series

## ■ PRODUCT LINEUP

Part number Item	MB89943	MB89945	MB89P945	MB89PV940
Classification	Mass-produced products (mask ROM products)		One-time PROM	Piggyback
ROM size	8 K × 8 bits (internal mask ROM)	16 K × 8 bits (internal mask ROM)	16 K × 8 bits (internal ROM)	32 K × 8 bits (external on piggyback)
RAM size	512 × 8 bits			1 K × 8 bits
CPU functions	The number of instructions: 136 Instruction cycle: 0.5 μs*1 @ 8 MHz Interrupt response time: 4.0 μs*1 @ 8 MHz Multiply instruction time: 19 instruction cycles Divide instruction time: 21 instruction cycles Direct addressing memory-to/from-register data transfer: 7 instruction cycles			
Ports	Output: 5-bit N-ch open-drain Input/Output: Two 8-bit CMOS schmitt I/Os and 8-bit CMOS I/Os			
Timebase timer	21 bits Interrupt interval: 1 ms, 4.1 ms, 32.8 ms or 524.3 ms			
8-bit/16-bit interval timer	Can be used as two 8-bit timers or one 16-bit timer Operation clock: 1 μs, 16 μs, 256 μs or external input *1			
Watchdog timer	Reset interval: Approx. 524 ms to 1049 ms			
Stepping motor controller	Two 8-bit PWM pulse generators Synchronized 4-channel high current output Operation clock: 250 ns, 500 ns, 1 μs or 4 μs*1			
8-bit PWM timers	Two 8-bit PWM timers			
External interrupt	3 channels, selective positive edge or negative edge trigger			
A/D converter	8-bit resolution, two-channel input A/D conversion time : (MB89943/945 : 26 μs*1/8 MHz oscillation, MB89P945/MB89PV940 : 22 μs*1/8MHz oscillation)			
LCD controller & driver	4-common and 17-segment outputs Number of outputs programmable			
Low supply voltage reset	Autonomous reset when low supply voltage Reset voltage: 3.3 V, 3.6 V, 4.0 V			
External voltage monitor interrupt	Interrupts when voltage at external pin is lower than the reference voltage			
Standby modes	Stop mode and sleep mode			
Operating voltage*2	3.5 V to 5.5 V			
Process	CMOS			
External EPROM				MBM27C256A-20TVM

\*1: Execution times and clock cycle times are dependent on the use of MCU.

\*2: Varies with conditions such as the operating frequency. (See section "■ Electrical Characteristics".) In the case of the MB89PV940, the voltage varies with the restrictions of the EPROM for use.

## ■ PACKAGE AND CORRESPONDING PRODUCTS

Package	MB89943 MB89945 MB89P945	MB89PV940
FPT-48P-M16	○	×
MQP-48C-P01	×	○

○ : Available    ×: Not available

Note: For more information about each package, see section “■ Package Dimensions”.

## ■ DIFFERENCES AMONG PRODUCTS

### 1. Memory Size

Prior to evaluating/developing the software for the MB89940 series, please check the differences between the product types.

- RAM/ROM configurations are dependent on the product type.
- If the bottom address of the stack is set to the upper limit of the RAM address, it should be relocated when changing the product type.

### 2. Power Dissipation

- For the piggyback product, add the power dissipation of the EPROM on the piggyback.
- The power dissipation differs between the product types.

### 3. Technology

The mask ROM product is fabricated with a 0.5 μm CMOS technology whereas the other products with 0.8 μm CMOS technology.

Also the mask ROM product contains the on-chip voltage regulator for the internal 3.0 power supply. For details, refer.

### 4. Mask Option

Functions that can be selected as options and how to designate these options vary by the product.

Before using options check section “■ Mask Options”.

- No options are available for the piggyback product.
- The power-on reset and reset output options are always activated with the mask ROM product.
- Pull-up option must not be specified with the pins used as LCD outputs.

# MB89940 Series

## ■ PIN ASSIGNMENT

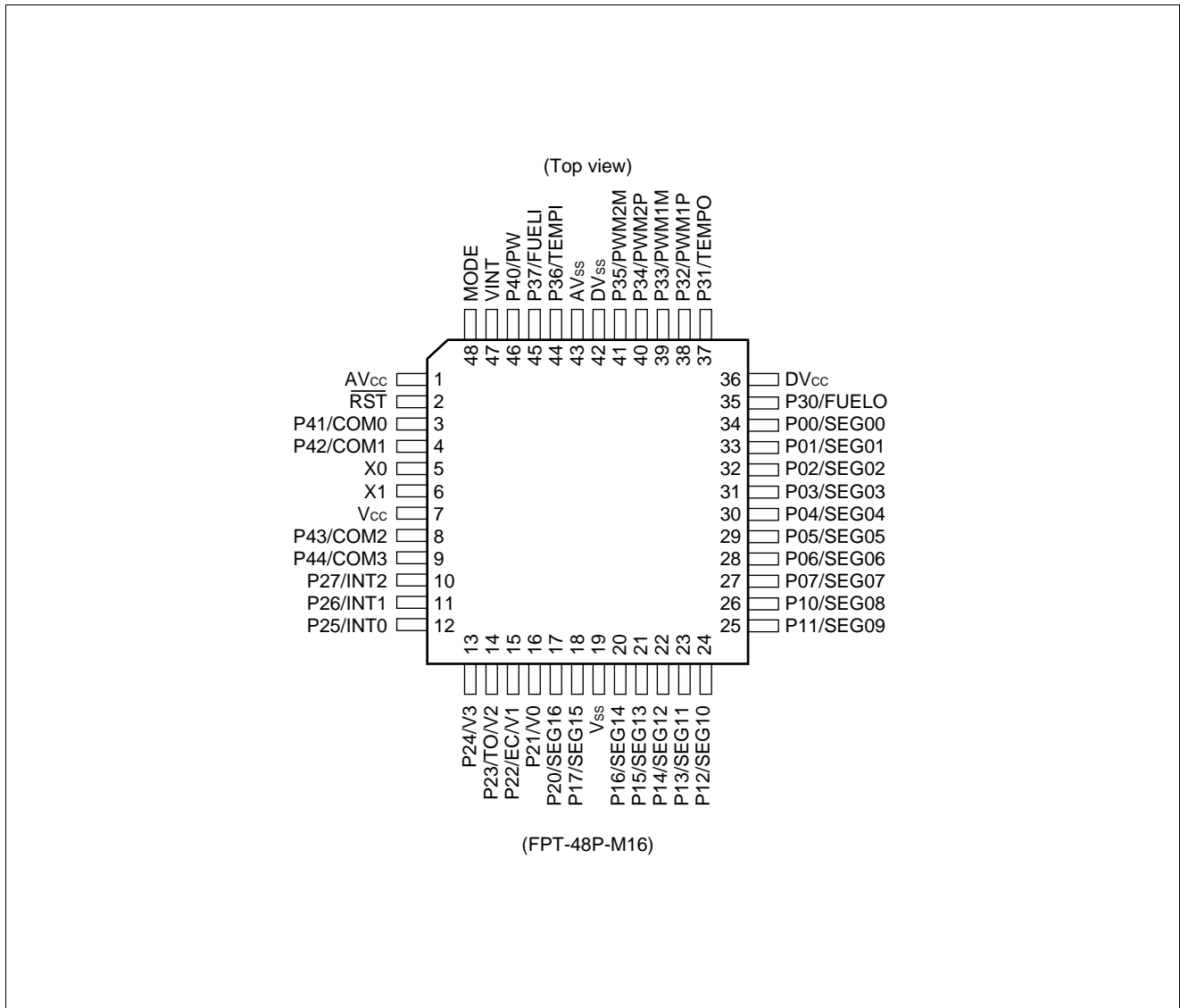

(Continued)

(Continued)

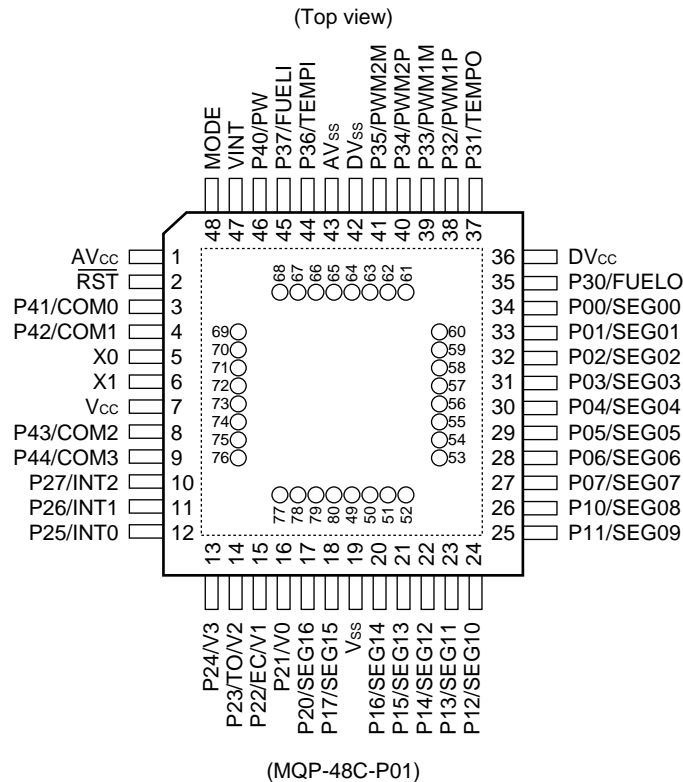

• Pin assignment on package top (MB89PV940 only)

Pin no.	Pin name	Pin no.	Pin name	Pin no.	Pin name	Pin no.	Pin name
49	A15	57	N.C.	65	O4	73	OE
50	A12	58	A2	66	O5	74	N.C.
51	A7	59	A1	67	O6	75	A11
52	A6	60	A0	68	O7	76	A9
53	A5	61	O1	69	O8	77	A8
54	A4	62	O2	70	CE	78	A13
55	A3	63	O3	71	A10	79	A14
56	N.C.	64	V <sub>ss</sub>	72	N.C.	80	V <sub>cc</sub>

N.C.: Internally connected. Do not use.

# MB89940 Series

## ■ PIN DESCRIPTION

Pin no.		Pin name	Circuit type	Function
QFP*1	MQFP*2			
5	5	X0	A	Pin for connecting the crystal resonator. X0 and X1 can be directly connected to a crystal oscillator. When the oscillation clock is provided to X0 externally, X1 should be left open.
6	6	X1		
48	48	MODE	B	The mode input is used for entering the MCU into the test mode. In user applications, MODE is connected to V <sub>ss</sub> .
2	2	$\overline{\text{RST}}$	C	Applying a reset pulse to this pin forces the MCU to enter the initial state. RST is active low and drives low state when an internal reset occurs. Reset pulses of the duration less than the minimum pulse width may cause the MCU to enter undefined states.
34 to 27	34 to 27	P00/SEG00 to P07/SEG07	H	These pins have two functions. Their functions can be switched between Port 0 and LCD segment signal outputs by setting the internal registers of the LCD controller.
26 to 20, 18	26 to 20, 18	P10/SEG08 to P17/SEG15	J	These pins have two functions. Their functions can be switched between Port 1 and LCD segment signal outputs by setting the internal registers of the LCD controller.
17	17	P20/SEG16	I	This pin can be used as the bit 0 of Port 2 or an LCD segment signal output by setting the internal register of the LCD controller.
16	16	P21/V0	F	This pin is the bit 1 of Port 2. This pin can also be used for an external LCD bias voltage input.
15	15	P22/EC/V1	F	This pin can be used as the bit 2 of Port 2 or the external clock input for the interval timer. This pin can also be used for an external LCD bias voltage input.
14	14	P23/TO/V2	F	This pin can be used as the bit 3 of Port 2 or the output for the interval timer. Its function can be switched by setting the internal register of the interval timer. This pin can also be used for an external LCD bias voltage input.
13	13	P24/V3	F	This pin can be used as the bit 4 of Port 2 or an external LCD bias voltage input.
12, 11, 10	12, 11, 10	P25/INT0 to P27/INT2	E	These pins are used for Port 2. They can also be used for external interrupt inputs.
35	35	P30/FUELO	D	This pin can be used for the bit 0 of Port 3 or the output from PWM3. The function of this pin can be switched by setting the internal register of PWM3.

\*1: FPT-48P-M16

\*2: MQP-48C-P01

(Continued)

# MB89940 Series

(Continued)

Pin no.		Pin name	Circuit type	Function
QFP*1	MQFP*2			
37	37	P31/TEMPO	G	This pin can be used for the bit 1 of Port 3 or the output from PWM4. The function of this pin can be switched by setting the internal register of PWM4. This output has a high drive-current capability.
38, 39	38, 39	P32/PWM1P, P33/PWM1M	G	These pins are the pair of high-current driver outputs for one of two motor coils. They can be also used for the bits 2 and 3 of Port 3 by setting the internal register of the stepper motor controller.
40, 41	40, 41	P34/PWM2P, P35/PWM2M	G	These pins are the pair of high-current driver outputs for one of two motor coils. They can be also used for the bits 4 and 5 of Port 3 by setting the internal register of the stepper motor controller.
44	44	P36/TEMPI	M	This analog input is connected to channel 1 of the A/D converter. It can also be used for the bit 6 of Port 3 when this A/D input enable register bit is set to '0'.
45	45	P37/FUELI	M	This analog input is connected to channel 0 of the A/D converter. It can also be used for the bit 7 of Port 3 when this A/D input enable register bit is set to '0'.
46	46	P40/PW	L	This pin has two functions. When this pin is used as an open-drain output of Port 4, the external voltage monitor reset should be in the power down mode. When it is used as the PW input of external voltage monitor reset, the corresponding bit of the port data register should be set to '1'.
3, 4, 8, 9	3, 4, 8, 9	P41/COM0 to P44/COM3	K	These pins are the LCD common signal outputs. When LCD is not used, these pins can be also used for Port 4.
47	47	VINT	—	An external capacitor should be connected to this pin for stabilizing the internal 3.0 V power supply. For MB89PV940 and MB89P945, this pin should be left open.
7	7	V <sub>CC</sub>	—	V <sub>CC</sub>
19	19	V <sub>SS</sub>	—	V <sub>SS</sub>
1	1	AV <sub>CC</sub>	—	The power supply pin for the analog circuit The same voltage should be applied as V <sub>CC</sub> .
43	43	AV <sub>SS</sub>	—	The power supply pin for the analog circuit The same voltage should be applied as V <sub>SS</sub> .
36	36	DV <sub>CC</sub>	—	The dedicated power supply pin for the high-current driver output The same voltage should be applied as V <sub>CC</sub> .
42	42	DV <sub>SS</sub>	—	The dedicated power supply pin for the high-current driver output The same voltage should be applied as V <sub>SS</sub> .

\*1: FPT-48P-M16

\*2: MQP-48C-P01

# MB89940 Series

- External EPROM pins (MB89PV940 only)

Pin no.	Pin name	I/O	Function
49 50 51 52 53 54 55 58 59 60	A15 A12 A7 A6 A5 A4 A3 A2 A1 A0	O	Address output pins
61 62 63 65 66 67 68 69	O1 O2 O3 O4 O5 O6 O7 O8	I	Data input pins
70	CE	O	ROM chip enable pin Outputs "H" during standby.
71	A10	O	Address output pin
73	OE	O	ROM output enable pin Outputs "L" at all times.
75 76 77 78 79	A11 A9 A8 A13 A14	O	Address output pin
80	V <sub>cc</sub>	O	EPROM power supply pin
64	V <sub>ss</sub>	O	Power supply (GND) pin
56 57 72 74	N.C.	—	Internally connected pins Be sure to leave them open.

## ■ I/O CIRCUIT TYPE

Type	Circuit	Remarks
A	<p>Standby control signal</p>	<ul style="list-style-type: none"> <li>Oscillator I/O</li> <li>With feedback resistor of approx. 1 MΩ.</li> </ul>
B		<ul style="list-style-type: none"> <li>Schmitt-trigger input</li> <li>(Pull-down resistance only for MB89943, MB89945)</li> </ul>
C		<ul style="list-style-type: none"> <li>Open-drain output with pull-up resistor</li> <li>(Approx. 50 kΩ).</li> <li>Schmitt-trigger input</li> <li>Hysteresis input</li> </ul>
D		<ul style="list-style-type: none"> <li>CMOS I/O</li> </ul>
E		<ul style="list-style-type: none"> <li>CMOS I/O (Schmitt trigger)</li> <li>Pull-up resistor optional</li> </ul>

(Continued)

# MB89940 Series

Type	Circuit	Remarks
F		<ul style="list-style-type: none"> <li>• CMOS I/O (Schmitt trigger)</li> <li>• External bias input</li> <li>• Pull-up resistor optional</li> </ul>
G		<ul style="list-style-type: none"> <li>• CMOS I/O (High output current)</li> </ul>
H		<ul style="list-style-type: none"> <li>• CMOS I/O</li> <li>• LCD controller/driver output</li> </ul>
I		<ul style="list-style-type: none"> <li>• CMOS I/O</li> <li>• LCD controller/driver output</li> <li>• Pull-up resistor optional</li> <li>• Hysteresis input</li> </ul>

(Continued)

(Continued)

Type	Circuit	Remarks
J		<ul style="list-style-type: none"> <li>• CMOS I/O</li> <li>• LCD controller/driver output</li> <li>• Pull-up resistor optional (Except P11/SEG09, P10/SEG08)</li> </ul>
K		<ul style="list-style-type: none"> <li>• N-ch open-drain output</li> <li>• LCD controller/driver output</li> </ul>
L		<ul style="list-style-type: none"> <li>• N-ch open-drain output</li> <li>• Analog input</li> </ul>
M		<ul style="list-style-type: none"> <li>• CMOS I/O</li> <li>• Analog input</li> </ul>

## ■ HANDLING DEVICES

### 1. Preventing Latchup

Latchup may occur on CMOS ICs if voltage higher than  $V_{CC}$  or lower than  $V_{SS}$  is applied to input and output pins other than medium- and high-voltage pins or if higher than the voltage which shows on “1. Absolute Maximum Ratings” in section “■ Electrical Characteristics” is applied between  $V_{CC}$  and  $V_{SS}$ .

When latchup occurs, power supply current increases rapidly and might thermally damage elements. When using, take great care not to exceed the absolute maximum ratings.

Also, take care to prevent the analog power supply ( $AV_{CC}$  and  $AVR$ ) and analog input from exceeding the digital power supply ( $V_{CC}$ ) when the analog system power supply is turned on and off.

### 2. Treatment of Unused Input Pins

Leaving unused input pins open could cause malfunctions. They should be connected to a pull-up or pull-down resistor.

The VINT pin of MB89PV940 and MB89P945 is the only exception.

### 3. Treatment of Power Supply Pins on Microcontrollers with A/D Converter

Connect to be  $AV_{CC} = V_{CC}$  and  $AV_{SS} = V_{SS}$  even if the A/D converter are not in use.

### 4. Treatment of N.C. Pins

Be sure to leave (internally connected) N.C. pins open.

### 5. Power Supply Voltage Fluctuations

Although  $V_{CC}$  power supply voltage is assured to operate within the rated range, a rapid fluctuation of the voltage could cause malfunctions, even if it occurs within the rated range. Stabilizing voltage supplied to the IC is therefore important. As stabilization guidelines, it is recommended to control power so that  $V_{CC}$  ripple fluctuations (P-P value) will be less than 10% of the standard  $V_{CC}$  value at the commercial frequency (50 to 60 Hz) and the transient fluctuation rate will be less than 0.1 V/ms at the time of a momentary fluctuation such as when power is switched.

### 6. Note to Noise in the External Reset Pin ( $\overline{RST}$ )

If the reset pulse applied to the external reset pin ( $\overline{RST}$ ) does not meet the specifications, it may cause malfunctions. Use caution so that the reset pulse less than the specifications will not be fed to the external reset pin ( $\overline{RST}$ ).

## PROGRAMMING TO THE EPROM ON THE MB89P945

### 1. Programming MB89P945

Using the EPROM adapter (provided by Sun Hayato Co., Ltd.) and a standard EPROM programmer, user-defined data can be written into the OTPROM and option PROM. The EPROM programmer should be set to MB27C256A-20TVM and electro-signature mode should not be used. When programming the data, the internal addresses are mapped as follows.

### 2. Memory Space

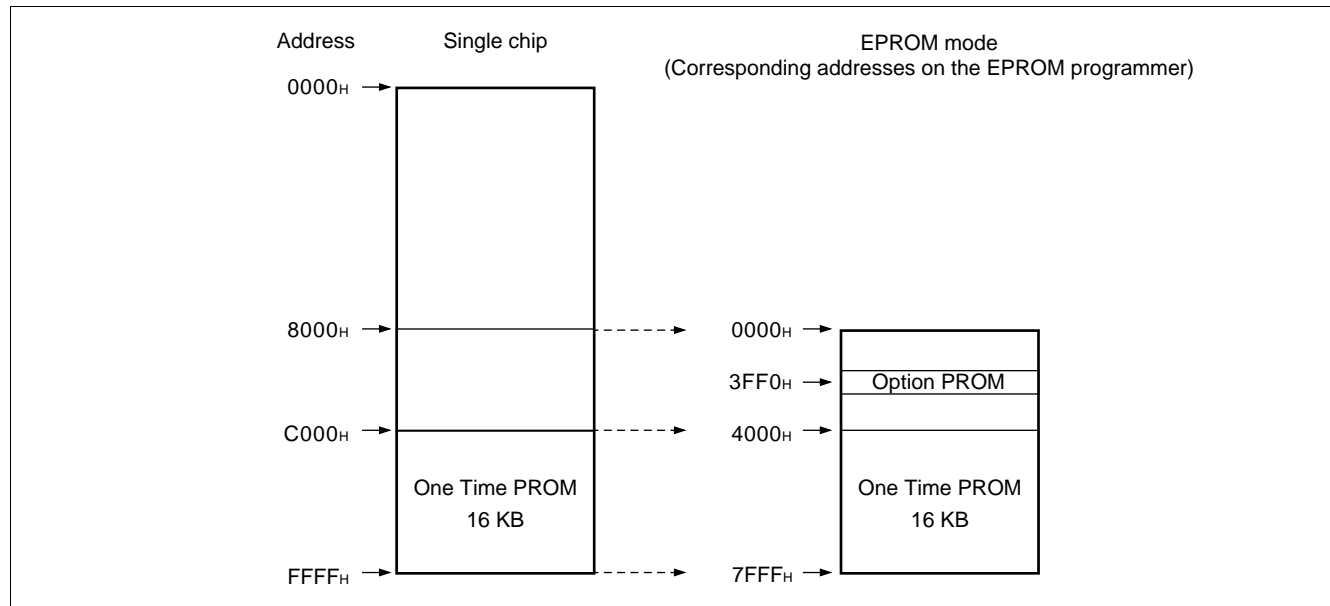

### 3. Screening MB89P945

It is recommended that high-temperature aging is performed on the MB89P945 prior to the assembly.

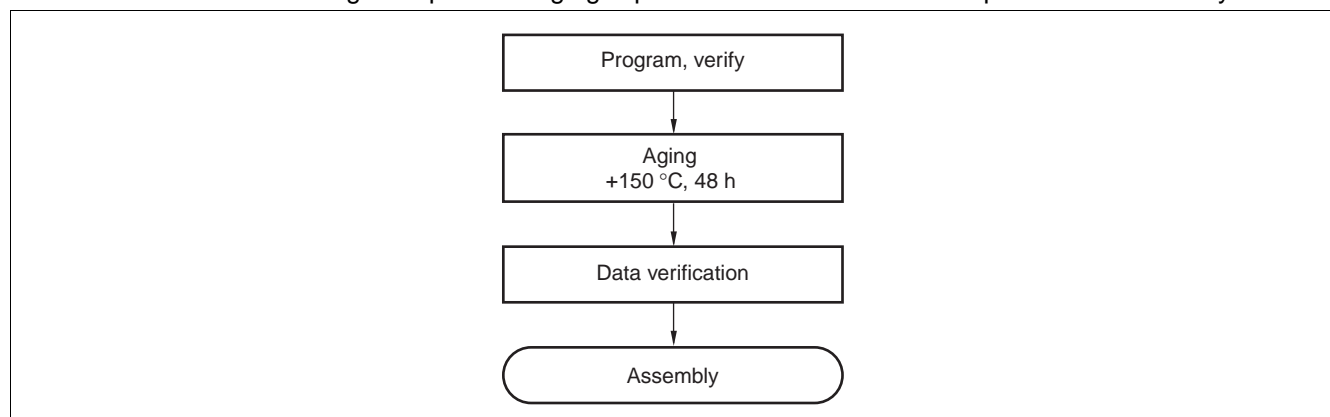

# MB89940 Series

## 4. Setting PROM Options

For MB89P945, mask options are described in the internal option PROM area. The table below shows the bit map of the option PROM. The option data can be written by a standard EPROM programmer.

- PROM option bit map

PROM Address	Bit 7	Bit 6	Bit 5	Bit 4	Bit 3	Bit 2	Bit 1	Bit 0
3FF0 <sub>H</sub>	Unused	Unused	Unused	Reserved	Reset output 1: Active 0: Inactive	Power-on reset 1: Active 0: Inactive	Oscillation stabilization time 11: 2 <sup>18</sup> T <sub>osc</sub> 10: 2 <sup>17</sup> T <sub>osc</sub> 01: 2 <sup>14</sup> T <sub>osc</sub>	
3FF1 <sub>H</sub>	P17 Pull-up 1: Inactive 0: Active	P16 Pull-up 1: Inactive 0: Active	P15 Pull-up 1: Inactive 0: Active	P14 Pull-up 1: Inactive 0: Active	P13 Pull-up 1: Inactive 0: Active	P12 Pull-up 1: Inactive 0: Active	Unused	Unused
3FF2 <sub>H</sub>	P27 Pull-up 1: Inactive 0: Active	P26 Pull-up 1: Inactive 0: Active	P25 Pull-up 1: Inactive 0: Active	P24 Pull-up 1: Inactive 0: Active	P23 Pull-up 1: Inactive 0: Active	P22 Pull-up 1: Inactive 0: Active	P21 Pull-up 1: Inactive 0: Active	P20 Pull-up 1: Inactive 0: Active
3FF3 <sub>H</sub>	Unused	Unused	Unused	Low volt. PDX bit	Low volt. S1 bit	Low volt. S0 bit	Low volt. LVE bit	Low volt. 1: Register active 0: Option active
3FF4 <sub>H</sub>	Unused	Unused	Unused	Unused	Unused	Unused	Unused	Unused
3FF5 <sub>H</sub>	Unused	Unused	Unused	Unused	Unused	Unused	Unused	Unused
3FF6 <sub>H</sub>	Unused	Unused	Unused	Unused	Unused	Unused	Unused	Unused

- Notes:
- Default values are all '1'.
  - T<sub>osc</sub>: One oscillation clock cycle time
  - When the bit0 of "3FF3<sub>H</sub>" is "0", it activates the option setting for the Low Voltage Reset Control register.
  - When this option is activated, software setting in the register has no effect.

## 5. Programming Yield

All bits cannot be programmed at Fujitsu shipping test to a blanked OTPROM microcomputer, due to its nature. For this reason, a programming yield of 100% cannot be assured at all times.

## ■ PROGRAMMING TO THE EPROM WITH PIGGYBACK/EVALUATION DEVICE

### 1. EPROM for Use

MBM27C256A-20TVM

### 2. Memory Space

The memory space of the piggyback EPROM is mapped onto the internal memory space as shown in the figure below.

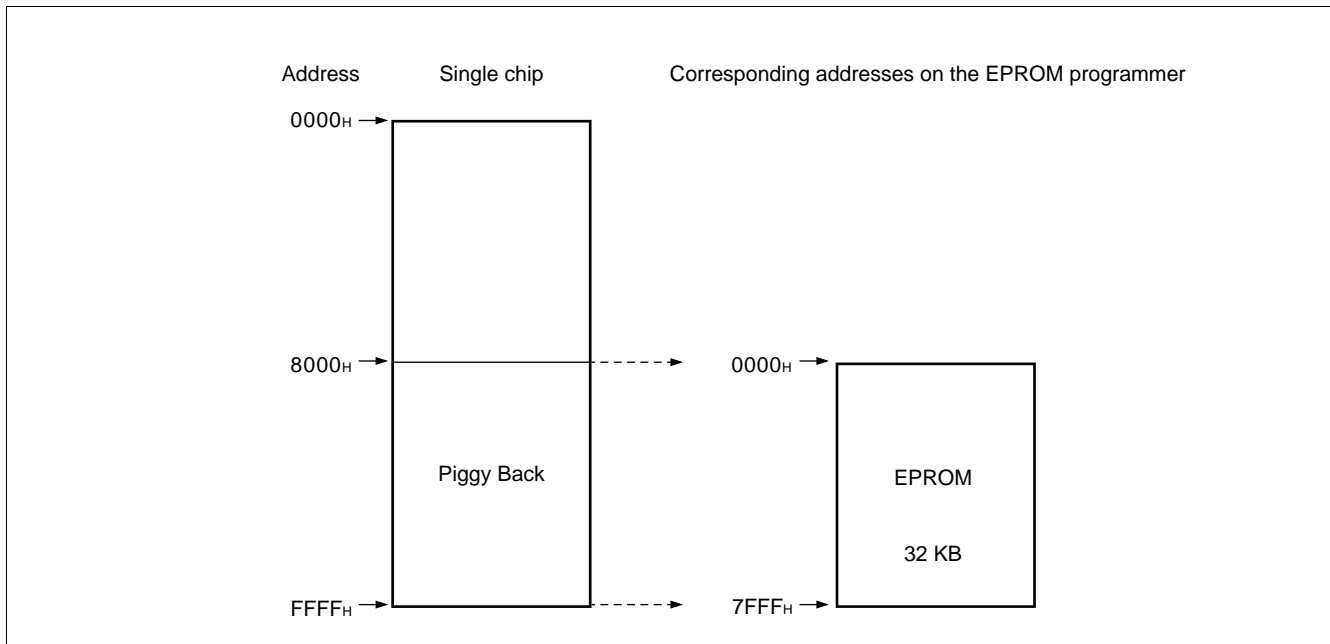

For EPROM devices suitable for MB89PV940, please contact sales representatives.

### 3. Programming to the EPROM

- (1) Set the EPROM programmer to the MBM27C256A-20TVM.
- (2) Load program data into the EPROM programmer at 0000<sub>H</sub> to 7FFF<sub>H</sub>.
- (3) Program to 0000<sub>H</sub> to 7FFF<sub>H</sub> with the EPROM programmer.

# MB89940 Series

## ■ BLOCK DIAGRAM

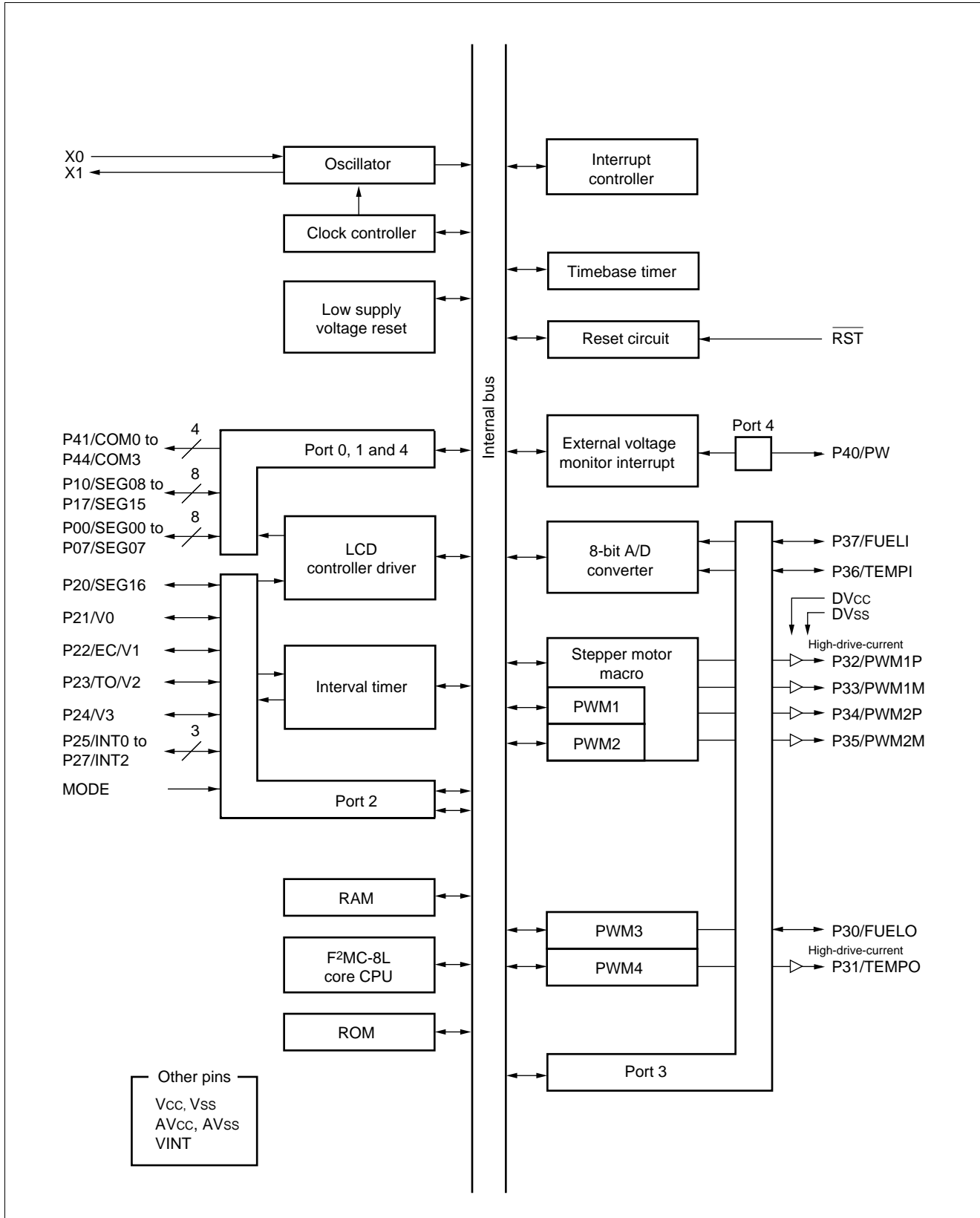

## ■ CPU CORE

### 1. Memory Space

The MB89940 Series has a memory space of 64 Kbytes. All peripheral registers, RAM and ROM areas are mapped onto the 0000<sub>H</sub> to FFFF<sub>H</sub> range. The peripheral registers address below 007F<sub>H</sub> and the RAM addresses the range 0080<sub>H</sub> to 027F<sub>H</sub> (0080<sub>H</sub> to 047F<sub>H</sub> for MB89PV940). A part of this RAM area is also assigned as the general-purpose registers. The ROM addresses above E000<sub>H</sub> for MB89943, or C000<sub>H</sub> for MB89945. The One-Time PROM addresses the range above C000<sub>H</sub>. The external ROM for the piggy sample addresses the range above 8000<sub>H</sub>. The reset vector, interrupt vectors and vectors for vector-call instructions are stored in the highest addresses of the memory space.

#### Memory Space

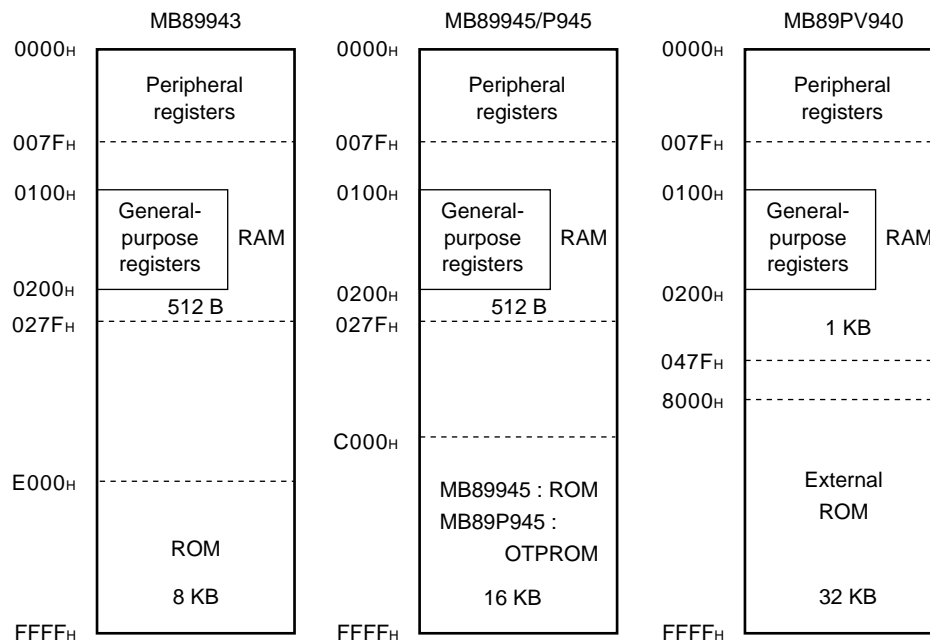

# MB89940 Series

## 2. Registers

The F<sup>2</sup>MC-8L family has two types of registers; dedicated registers in the CPU and general-purpose registers in the memory. The following dedicated registers are provided:

- Program counter (PC):           A 16-bit register for indicating instruction storage positions
- Accumulator (A):                A 16-bit temporary register for storing arithmetic operations, etc. When the instruction is an 8-bit data processing instruction, the lower byte is used.
- Temporary accumulator (T):    A 16-bit register which performs arithmetic operations with the accumulator  
When the instruction is an 8-bit data processing instruction, the lower byte is used.
- Index register (IX):            A 16-bit register for index modification
- Extra pointer (EP):            A 16-bit pointer for indicating a memory address
- Stack pointer (SP):            A 16-bit register for indicating a stack area
- Program status (PS):            A 16-bit register for storing a register pointer, a condition code

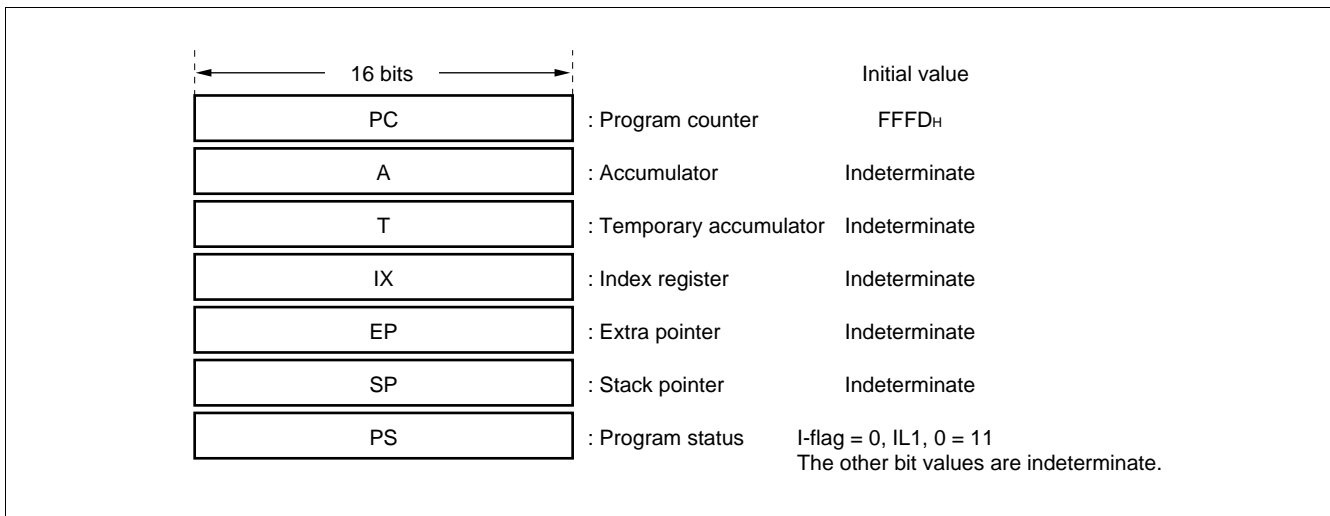

The PS can further be divided into higher 8 bits for use as a register bank pointer (RP) and the lower 8 bits for use as a condition code register (CCR). (See the diagram below.)

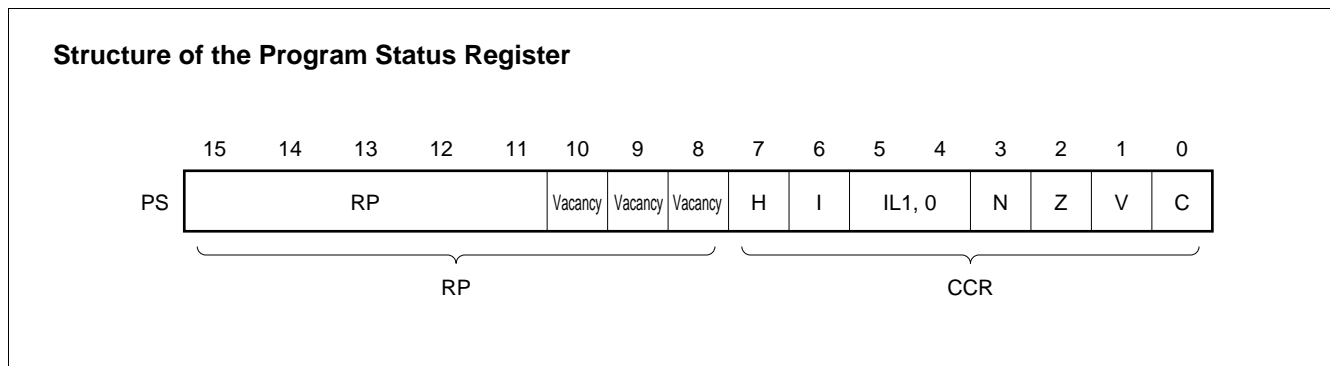

The RP indicates the address of the register bank currently in use. The relationship between the pointer contents and the actual address is based on the conversion rule illustrated below.

### Rule for Conversion of Actual Addresses of the General-purpose Register Area

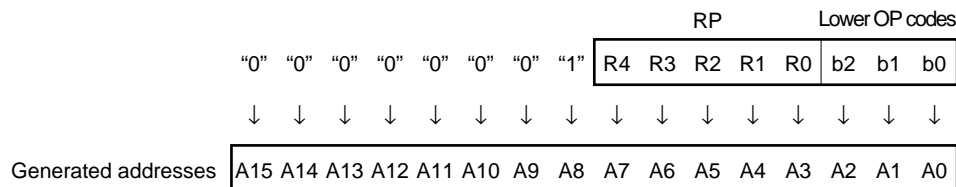

The CCR consists of bits indicating the results of arithmetic operations and the contents of transfer data and bits for control of CPU operations at the time of an interrupt.

H-flag: Set to '1' when a carry or a borrow from bit3 to bit4 occurs as a result of an arithmetic operation. Cleared otherwise. This flag is for decimal adjustment instructions.

I-flag: Interrupt is enabled when this flag is set to '1'. Interrupt is disabled when the flag is cleared to '0'. Cleared to '0' at the reset.

IL1, 0: Indicates the level of the interrupt currently allowed. Processes an interrupt only if its request level is higher than the value indicated by this bit.

IL1	ILO	Interrupt level	High-low
0	0	1	High
0	1		<div style="text-align: center;"> ↑  ↓ </div>
1	0	2	
1	1	3	

N-flag: Set to '1' if the MSB becomes '1' as the result of an arithmetic operation. Cleared to '0' otherwise.

Z-flag: Set to '1' when an arithmetic operation results in 0. Cleared to '0' otherwise.

V-flag: Set to '1' if the complement on '2' overflows as a result of an arithmetic operation. Cleared to '0' if the overflow does not occur.

C-flag: Set to '1' when a carry or a borrow from bit7 occurs as a result of an arithmetic operation. Cleared to '0' otherwise. Set to '1' to the shift-out value in the case of a shift instruction.

# MB89940 Series

The following general-purpose registers are provided:

General-purpose registers: An 8-bit register for storing data

The general-purpose registers are 8 bits and located in the register banks of the memory. One bank contains eight registers and up to a total of 32 banks can be used on the MB89940 series. The bank currently in use is indicated by the register bank pointer (RP).

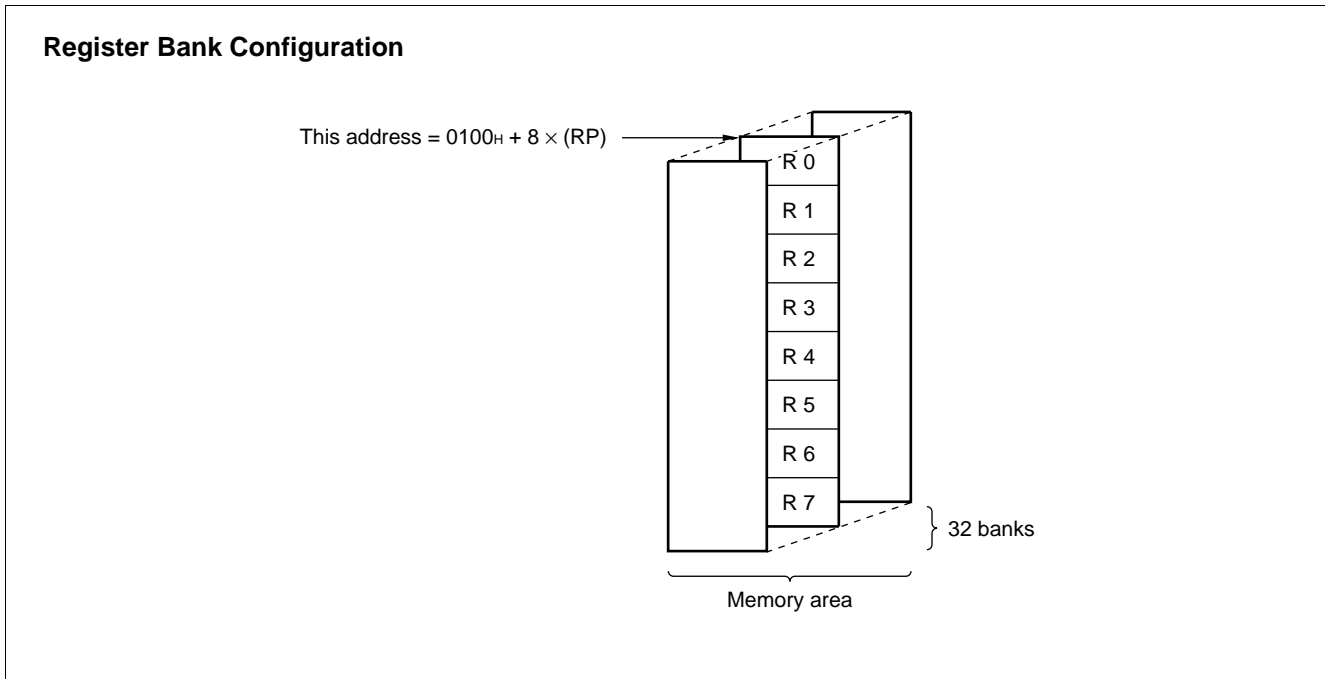

## ■ I/O MAP

Address	Read/write	Register name	Register description
00H	(R/W)	PDR0	Port 0 data register
01H	(W)	PDD0	Port 0 data direction register
02H	(R/W)	PDR1	Port 1 data register
03H	(W)	PDD1	Port 1 data direction register
04H to 06H			Vacancy
07H	(R/W)	SCC	System clock control register
08H	(R/W)	SMC	Standby mode control register
09H	(R/W)	WDTC	Watchdog timer control register
0AH	(R/W)	TBTC	Timebase timer control register
0BH	(R/W)	LVRC	Low voltage reset control
0CH	(R/W)	PDR2	Port 2 data register
0DH	(W)	PDD2	Port 2 data direction register
0EH	(R/W)	PDR3	Port 3 data register
0FH	(W)	PDD3	Port 3 data direction register
10H	(R/W)	PDR4	Port 4 data register
11H	(R/W)	ADE	Port 3 A/D input enable register
12H to 17H			Vacancy
18H	(R/W)	T2CR	Timer 2 control register
19H	(R/W)	T1CR	Timer 1 control register
1AH	(R/W)	T2DR	Timer 2 data register
1BH	(R/W)	T1DR	Timer 1 data register
1CH to 1FH			Vacancy
20H	(R/W)	ADC1	A/D converter control register 1
21H	(R/W)	ADC2	A/D converter control register 2
22H	(R/W)	ADCD	A/D converter data register
23H	(R/W)	CNTR	PWM control register
24H	(W)	COMP1	PWM1 compare register
25H			Vacancy
26H	(W)	COMP2	PWM2 compare register
27H	(R/W)	SELR1	PWM1 select register
28H	(R/W)	SELR2	PWM2 select register
29H	(R/W)	CNTR3	PWM3 control register
2AH	(W)	COMP3	PWM3 compare register
2BH	(R/W)	CNTR4	PWM4 control register

(Continued)

# MB89940 Series

(Continued)

Address	Read/write	Register name	Register description
2C <sub>H</sub>	(W)	COMP4	PWM4 compare register
2D <sub>H</sub>	(R/W)	SELT	Selector test register
2E <sub>H</sub>	(R/W)	PFC	Power fail control register
2F <sub>H</sub>	(R/W)	EIR1	External interrupt control 1 register
30 <sub>H</sub>	(R/W)	EIR2	External interrupt control 2 register
31 <sub>H</sub> to 5F <sub>H</sub>			Vacancy
60 <sub>H</sub> to 68 <sub>H</sub>	(R/W)	VRAM	Display data RAM
69 <sub>H</sub> to 71 <sub>H</sub>			Vacancy
72 <sub>H</sub>	(R/W)	LCR1	LCD controller/driver 1 register
73 <sub>H</sub>	(R/W)	LCR2	LCD controller/driver 2 register
74 <sub>H</sub> to 7B <sub>H</sub>			Vacancy
7C <sub>H</sub>	(W)	ILR1	Interrupt level setting register 1
7D <sub>H</sub>	(W)	ILR2	Interrupt level setting register 2
7E <sub>H</sub>	(W)	ILR3	Interrupt level setting register 3
7F <sub>H</sub>			Vacancy

## ■ ELECTRICAL CHARACTERISTICS

### 1. Absolute Maximum Ratings

( $V_{SS} = 0.0\text{ V}$ )

Parameter	Symbol	Rating		Unit	Remarks
		Min	Max		
Power supply voltage	$V_{CC}$	$V_{SS} - 0.3$	$V_{SS} + 6.5$	V	
	$AV_{CC}$	$V_{SS} - 0.3$	$V_{SS} + 6.5$	V	Should not exceed $V_{CC}$
	$DV_{CC}$	$V_{SS} - 0.3$	$V_{SS} + 6.5$	V	Should not exceed $V_{CC}$
Input voltage	$V_{I1}$	$V_{SS} - 0.3$	$V_{CC} + 0.3$	V	Except P31 to P35 and P41 to P44
	$V_{I2}$	$V_{SS} - 0.3$	$DV_{CC} + 0.3$	V	P31 to P35
	$V_{I3}$	$V_{SS} - 0.3$	$V_{SS} + 6.5$	V	P41 to P44 MB89PV940/P945
	$V_{I4}$	$V_{SS} - 0.3$	$V_{CC} + 0.3$	V	P41 to P44 MB89943/945
Output voltage	$V_{O1}$	$V_{SS} - 0.3$	$V_{CC} + 0.3$	V	Except P31 to P35 and P41 to P44
	$V_{O2}$	$V_{SS} - 0.3$	$DV_{CC} + 0.3$	V	P31 to P35
	$V_{O3}$	$V_{SS} - 0.3$	$V_{SS} + 6.5$	V	P41 to P44 MB89PV940/P945
	$V_{O4}$	$V_{SS} - 0.3$	$V_{CC} + 0.3$	V	P41 to P44 MB89943/945
“L” level maximum output current	$I_{OL}$	—	20	mA	Except P31 to P35
		—	50	mA	P31 to P35
“L” level average output current	$I_{OLAV}$	—	4	mA	Except P31 to P35
		—	40	mA	P31 to P35
“L” level total maximum output current	$\Sigma I_{OL}$	—	100	mA	Except P31 to P35
		—	200	mA	P31 to P35
“L” level total average output current	$\Sigma I_{OLAV}$	—	40	mA	Except P31 to P35
		—	100	mA	P31 to P35
“H” level maximum output current	$I_{OH}$	—	-20	mA	Except P31 to P35
		—	-50	mA	P31 to P35
“H” level average output current	$I_{OHAV}$	—	-4	mA	Except P31 to P35
		—	-40	mA	P31 to P35
“H” level total maximum output current	$\Sigma I_{OH}$	—	-50	mA	Except P31 to P35
		—	-200	mA	P31 to P35
“H” level total average output current	$\Sigma I_{OHAV}$	—	-20	mA	Except P31 to P35
		—	-100	mA	P31 to P35
Power consumption	$P_D$	—	300	mW	
Operating temperature	$T_A$	-40	+85	°C	
Storage temperature	$T_{stg}$	-55	+150	°C	

WARNING: Semiconductor devices can be permanently damaged by application of stress (voltage, current, temperature, etc.) in excess of absolute maximum ratings. Do not exceed these ratings.

# MB89940 Series

## 2. Recommended Operating Conditions

(AV<sub>CC</sub> = V<sub>CC</sub> = DV<sub>CC</sub> = 5.0 V, V<sub>SS</sub> = AV<sub>SS</sub> = DV<sub>SS</sub> = 0.0 V)

Parameter	Symbol	Value			Unit	Remarks
		Min	Typ	Max		
Operating supply voltage range	V <sub>CC</sub> AV <sub>CC</sub> DV <sub>CC</sub>	3.5	—	5.5	V	
RAM data retention supply voltage range	V <sub>CC</sub> AV <sub>CC</sub> DV <sub>CC</sub>	3.0	—	5.5	V	
Smoothing capacitor	C <sub>VINT</sub>	0.1	—	1.0	μF	MB89943/MB89945 only*
Operating temperature range	T <sub>A</sub>	-40	—	+85	°C	

\*: Use either a ceramic capacitor or a capacitor with similar frequency characteristics. The bypass capacitor of V<sub>CC</sub> pin should be greater than C<sub>VINT</sub>.

**WARNING:** The recommended operating conditions are required in order to ensure the normal operation of the semiconductor device. All of the device's electrical characteristics are warranted when the device is operated within these ranges.

Always use semiconductor devices within their recommended operating condition ranges. Operation outside these ranges may adversely affect reliability and could result in device failure.

No warranty is made with respect to uses, operating conditions, or combinations not represented on the data sheet. Users considering application outside the listed conditions are advised to contact their representatives beforehand.

Figure1 VINT Pin Connection Diagram

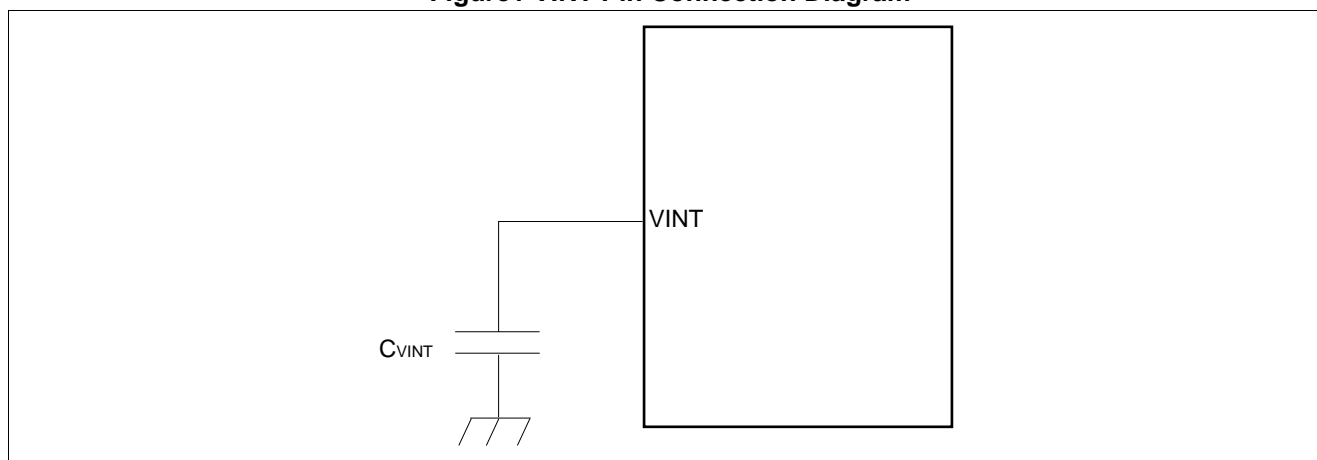
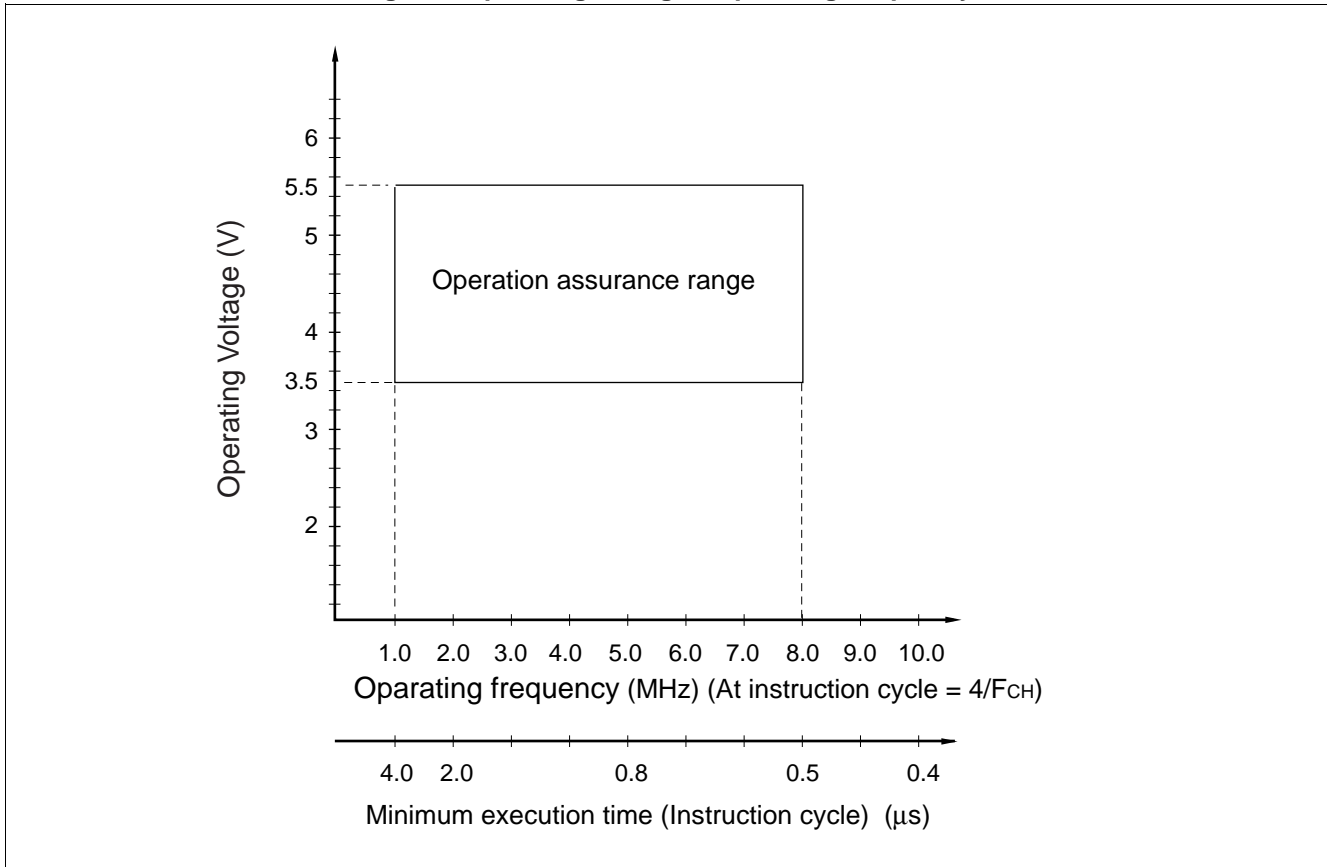

Figure2 Operating voltage - Operating frequency



# MB89940 Series

## 3. DC Characteristics

( $A_{V_{CC}} = V_{CC} = DV_{CC} = 5.0\text{ V}$ ,  $V_{SS} = AV_{SS} = DV_{SS} = 0.0\text{ V}$ )

Parameter	Symbol	Pin name	Condition	Value			Unit	Remarks
				Min	Typ	Max		
“H” level input voltage	$V_{IH}$	P00 to P07, P10 to P17, P30 to P37, P40 to P47	—	$0.7 V_{CC}$	—	$V_{CC} + 0.3$	V	
	$V_{IHS}$	$\overline{RST}$ , MODE, P20 to P27	—	$0.8 V_{CC}$	—	$V_{CC} + 0.3$	V	
“L” level input voltage	$V_{IL}$	P00 to P07, P10 to P17, P30 to P37, P40 to P47	—	$V_{SS} - 0.3$	—	$0.3 V_{CC}$	V	
	$V_{ILS}$	$\overline{RST}$ , MODE, P20 to P27	—	$V_{SS} - 0.3$	—	$0.2 V_{CC}$	V	
Open-drain output pin application voltage	$V_D$	P40	—	$V_{SS} - 0.3$	—	$V_{CC} + 0.3$	V	
	$V_{D2}$	P41 to P44	—	$V_{SS} - 0.3$	—	$V_{SS} + 5.5$	V	MB89PV940/P945
	$V_{D3}$	P41 to P44	—	$V_{SS} - 0.3$	—	$V_{CC} + 0.3$	V	MB89943/945
“H” level output voltage	$V_{OH}$	P10 to P17, P20 to P27, P30, P36, P37	$I_{OH} = -2.0\text{ mA}$	4.0	—	—	V	
	$V_{OH2}$	P31 to P35	$I_{OH} = -30$ , $V_{CC} = DV_{CC}$	$V_{CC} - 0.5$	—	—	V	
“L” level output voltage	$V_{OL}$	P10 to P17, P20 to P27, P30, P36, P37, P40 to P44	$I_{OL} = 4.0\text{ mA}$	—	—	0.4	V	
	$V_{OL2}$	P31 to P35	$I_{OL} = 30\text{ mA}$ , $V_{SS} = DV_{SS}$	—	—	0.5	V	
Input leakage current	$I_{IL1}$	MODE, P10 to P17, P20 to P27, P30 to P37, P40 to P44	$0.0\text{ V} < V_i < V_{CC}$ , $V_{CC} = DV_{CC}$	-5	—	+5	$\mu\text{A}$	Without pull-up option
Pull-up resistance	$R_{PULL}$	$\overline{RST}$ , P12 to P17, P20 to P27	—	25	50	100	k $\Omega$	With pull-up option
LCD internal bias voltage resistor	$R_{LCD}$	V0-V1, V1-V2, V2-V3	—	50	100	200	k $\Omega$	

(Continued)

# MB89940 Series

(Continued)

( $AV_{CC} = V_{CC} = DV_{CC} = 5.0\text{ V}$ ,  $V_{SS} = AV_{SS} = DV_{SS} = 0.0\text{ V}$ )

Parameter	Symbol	Pin name	Condition	Value			Unit	Remarks
				Min	Typ	Max		
Power supply current	$I_{CC}$	$V_{CC}$	$F_C = 8\text{ MHz}$ , $t_{inst}^* = 0.5\text{ }\mu\text{s}$ , $I_{CC} = I(V_{CC})$ $+ I(DV_{CC})$	—	12	20	mA	MB89PV940
				—	12	20	mA	MB89943, MB89945, MB89P945
	$I_{CCS}$		$F_C = 8\text{ MHz}$ , $t_{inst}^* = 0.5\text{ }\mu\text{s}$ , $I_{CCS} = I(V_{CC})$ $+ I(DV_{CC})$ in Sleep mode	—	3	7	mA	
	$I_{CCH}$		In Stop mode, $T_A = 25^\circ\text{C}$ , $I_{CCH} = I(V_{CC})$ $+ I(DV_{CC})$	—	5	10	$\mu\text{A}$	
Input capacitance	$C_{IN}$	—	$f = 1\text{ MHz}$	—	10	—	pF	

\*: For information on  $t_{inst}$ , see "(4) Instruction Cycle" in "4. AC Characteristics".

# MB89940 Series

## 4. AC Characteristics

### (1) Reset Timing

( $A_{V_{SS}} = V_{SS} = DV_{SS}$ ,  $T_A = -40^{\circ}\text{C}$  to  $+85^{\circ}\text{C}$ )

Parameter	Symbol	Condition	Value		Unit	Remarks
			Min	Max		
$\overline{\text{RST}}$ "L" pulse width	$t_{\text{LZH}}$	—	48 $t_{\text{HCYL}}$	—	ns	

$t_{\text{HCYL}}$ : One oscillation clock cycle time

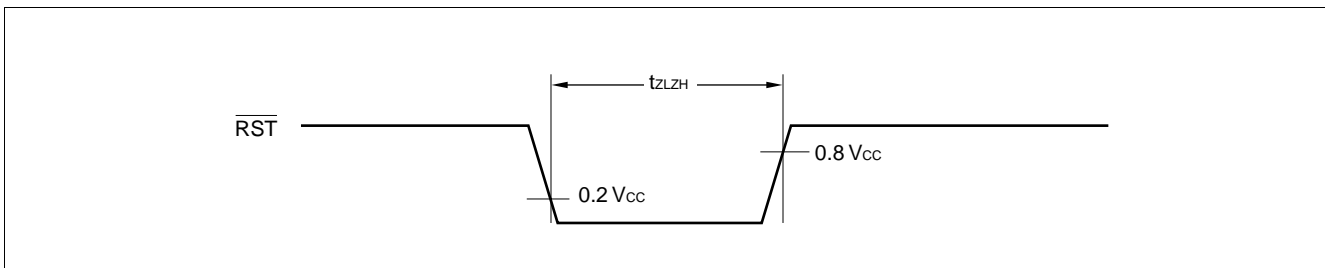

Notes: • If power-on reset option is not activated, the external reset signal must be kept asserted until the oscillation is stabilized.

- If the reset pulse applied to the external reset pin ( $\overline{\text{RST}}$ ) does not meet the specifications, it may cause malfunctions. Use caution so that the reset pulse less than the specifications will not be fed to the external reset pin ( $\overline{\text{RST}}$ ).

### (2) Power-on Profile

( $A_{V_{SS}} = V_{SS} = DV_{SS}$ ,  $T_A = -40^{\circ}\text{C}$  to  $+85^{\circ}\text{C}$ )

Parameter	Symbol	Condition	Value		Unit	Remarks
			Min	Max		
Power supply voltage rising time	$t_r$	—	—	50	ms	MB89PV940, MB89P945
			—	$2^{19} t_{\text{HCYL}}$	ns	MB89943, MB89945
Power-off minimum period	$t_{\text{OFF}}$	—	1	—	ms	

$t_{\text{HCYL}}$ : One oscillation clock cycle time

Note: Power supply voltage should reach the minimum operation voltage within the specified default duration of the oscillation stabilization time.

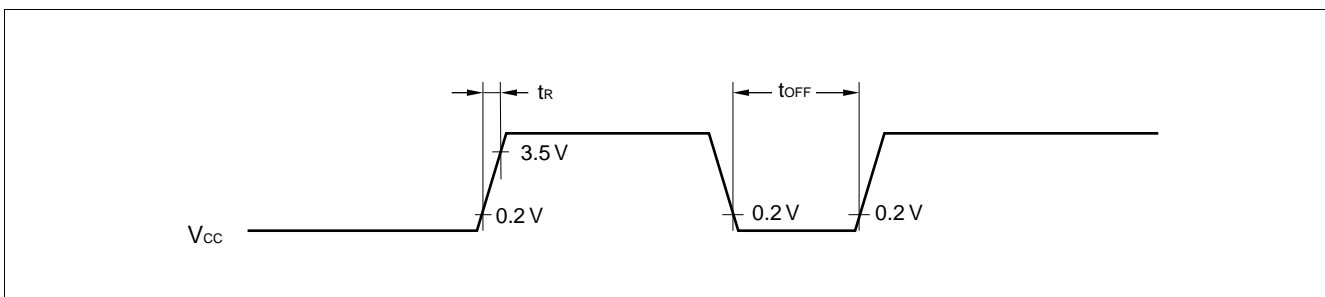

## (3) Clock Timing

( $V_{SS} = V_{SS} = DV_{SS}$ ,  $T_A = -40^{\circ}\text{C}$  to  $+85^{\circ}\text{C}$ )

Parameter	Symbol	Condition	Value		Unit	Remarks
			Min	Max		
Clock frequency	$F_C$	—	1	8	MHz	
Clock cycle time	$t_{CYC}$		125	1000	ns	
Input clock pulse width	$t_{WH}$ $t_{WL}$		20	—	ns	
Input clock rising/falling time	$t_{CR}$ $t_{CF}$		—	10	ns	

### X0 and X1 Timing and Conditions

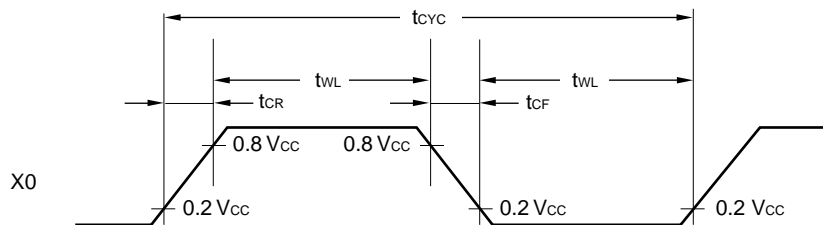

### Clock Conditions

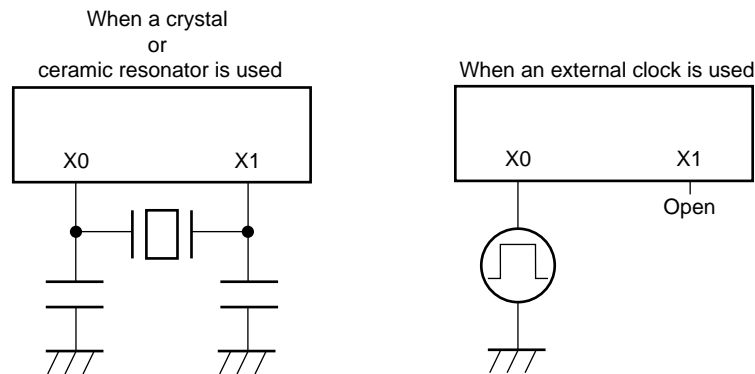

## (4) Instruction Cycle

Parameter	Symbol	Value (typical)	Unit	Remarks
Instruction cycle (minimum execution time)	$t_{inst}$	$4/F_C$ , $8/F_C$ , $16/F_C$ , $64/F_C$	$\mu\text{s}$	$(4/F_C) t_{inst} = 0.5 \mu\text{s}$ when operating at $F_C = 8 \text{ MHz}$

Note : When operating at 8 MHz, the cycle varies with the set execution time.

# MB89940 Series

## (5) Peripheral Input Timing

( $V_{SS} = V_{SS} = DV_{SS}$ ,  $T_A = -40^{\circ}\text{C}$  to  $+85^{\circ}\text{C}$ )

Parameter	Symbol	Pin name	Value		Unit	Remarks
			Min	Max		
Peripheral input "H" pulse width	$t_{WH}$	INT0, INT1, INT2, EC	$2 t_{inst}^*$	—	$\mu\text{s}$	
Peripheral input "L" pulse width	$t_{WL}$	INT0, INT1, INT2, EC	$2 t_{inst}^*$	—	$\mu\text{s}$	

\*: For information on  $t_{inst}$ , see "(4) Instruction Cycle".

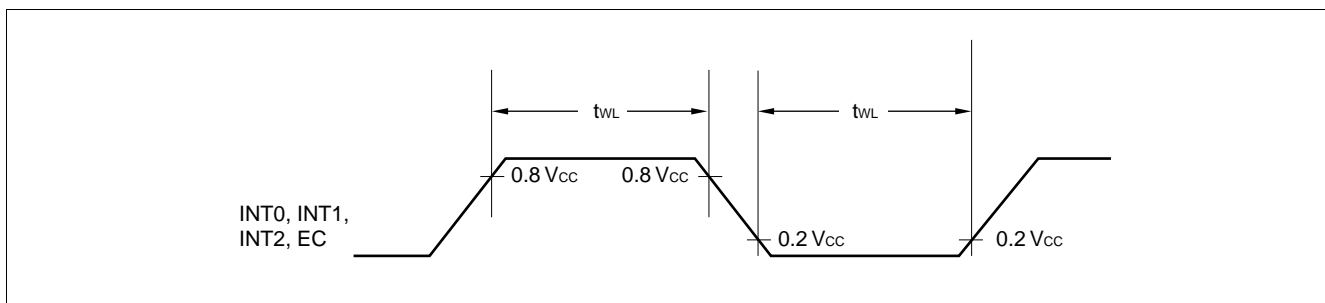

## 5. A/D Converter Electrical Characteristics

( $AV_{SS} = V_{SS} = DV_{SS}$ ,  $T_A = -40^{\circ}\text{C}$  to  $+85^{\circ}\text{C}$ )

Parameter	Symbol	Pin name	Condition	Value			Unit	Remarks
				Min	Typ	Max		
Resolution	—	—	—	—	—	8	bit	
Total error				—	—	$\pm 1.5$	LSB	
Nonlinearity error				—	—	$\pm 1.0$	LSB	
Differential linearity error				—	—	$\pm 0.9$	LSB	
Zero transition voltage	$V_{OT}$	—	—	$AV_{SS} - 1.0$ LSB	$AV_{SS} + 0.5$ LSB	$AV_{SS} + 2.0$ LSB	V	MB89PV940/ MB89P945
				$AV_{SS} - 1.0$ LSB	$AV_{SS} + 1.0$ LSB	$AV_{SS} + 2.0$ LSB	V	MB89943/ MB89945
Full-scale transition voltage	$V_{FST}$	—	—	$AV_{CC} - 3.0$ LSB	$AV_{CC} - 1.5$ LSB	$AV_{CC}$	V	MB89943/ MB89945/ MB89PV940/ MB89P945
Interchannel disparity	—	—	—	—	—	0.5	LSB	
A/D mode conversion time				—	—	$44 t_{inst}^*$	$\mu\text{s}$	MB89PV940/ MB89P945
				—	—	$52 t_{inst}^*$	$\mu\text{s}$	MB89943/ MB89945
Power supply current	$I_A$	$AV_{CC}$	$F_C = 8 \text{ MHz}$ , $I_A = I(AV_{CC})$ A/D in operation	—	6	8	mA	
	$I_{AH}$	—	$F_C = 8 \text{ MHz}$ , $I_{AH} = I(AV_{CC})$ A/D stopped	—	5	10	$\mu\text{A}$	
Analog input current	$I_{AIN}$	—	—	—	—	10	$\mu\text{A}$	
Analog input voltage range	—	—	—	0	—	$AV_{CC}$	V	

\*: For information on  $t_{inst}$ , see "(4) Instruction Cycle" in "4. AC Characteristics".

## 6. A/D Converter Glossary

- Resolution  
Analog changes that are identifiable with the A/D converter  
When the number of bits is 8, analog voltage can be divided into  $2^8 = 256$ .
- Linearity error (unit: LSB)  
The deviation of the straight line connecting the zero transition point (“0000 0000” ↔ “0000 0001”) with the full-scale transition point (“1111 1111” ↔ “1111 1110”) from actual conversion characteristics
- Differential linearity error (unit: LSB)  
The deviation of input voltage needed to change the output code by 1 LSB from the theoretical value
- Total error (unit: LSB)  
The difference between theoretical and actual conversion values

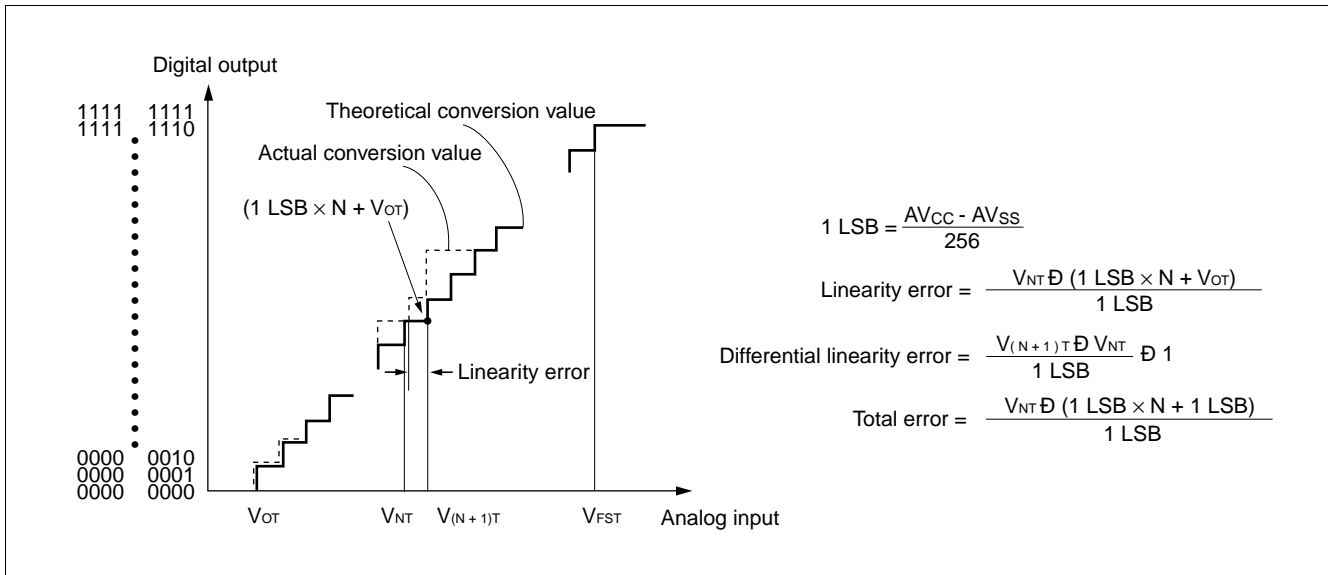

## 7. Notes on Using A/D Converter

### • Input impedance of the analog input pins

The A/D converter used for the MB89940 series contains a sample & hold circuit as illustrated below to fetch analog input voltage into the sample hold capacitor for eight instruction cycles after activating A/D conversion.

For this reason, if the output impedance of the external circuit for the analog input is high, analog input voltage might not stabilize within the analog input sampling period. Therefore, it is recommended to keep the output impedance of the external circuit low (below 10 k $\Omega$ ).

Note that if the impedance cannot be kept low, it is recommended to connect an external capacitor of about 0.1  $\mu$ F for the analog input pin.

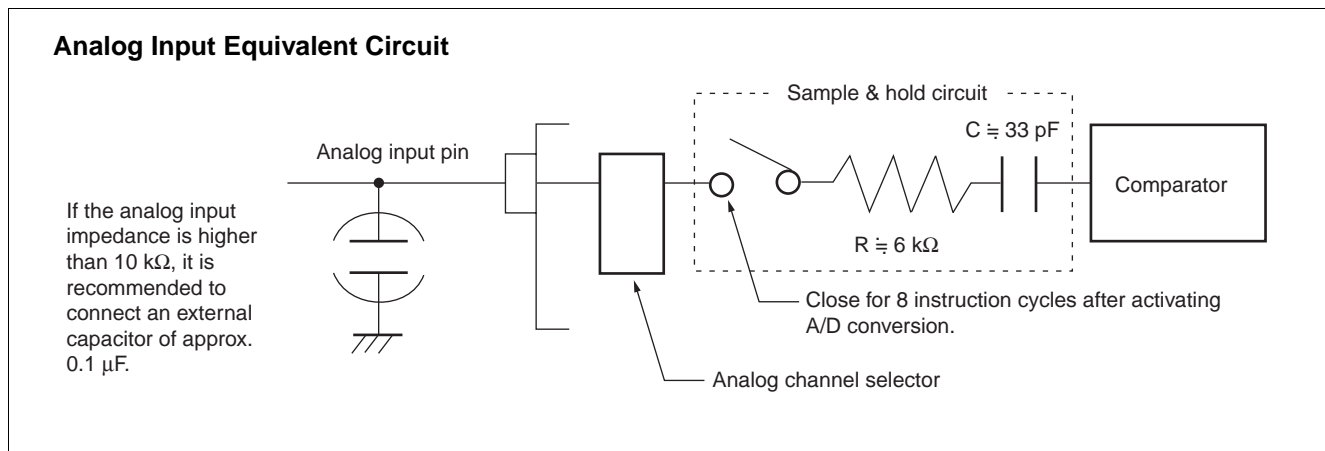

### • Error

The smaller the  $|AV_{CC} - AV_{SS}|$ , the greater the error would become relatively.

# MB89940 Series

## 8. Low Supply Voltage Reset Electrical Characteristics

Parameter	Symbol	Value		Unit	Remarks
		Min	Max		
Reset voltage	$V_{DL1}$	3.0	3.6	V	When the voltage is dropping.
	$V_{DL2}$	3.3	3.9	V	
	$V_{DL3}$	3.7	4.3	V	
Hysteresis of reset voltage	$V_{HYS}$	0.1	—	V	When the voltage is recovering.
Delay time to reset	$t_D$	—	2.0	$\mu\text{s}$	
Supply voltage slew rate	$dV/dt$	—	0.1	$V/\mu\text{s}$	

## 9. External Voltage Monitor Interrupt Electrical Characteristics

Parameter	Symbol	Value		Unit	Remarks
		Min	Max		
Reference voltage	$V_{REF}$	1.18	1.38	V	
Delay time to interrupt	$T_D$	—	2.0	$\mu\text{s}$	
Input slew rate	$dV/dt$	—	0.1	$V/\mu\text{s}$	

## ■ MASK OPTIONS

No.	Part number	MB89943/MB89945	MB89P945	MB89PV940
	Specifying procedure	Specify when ordering masking	Set with EPROM Programmer	Setting not possible
1	Pull-up resistors <ul style="list-style-type: none"> <li>┌ P12 to P17,</li> <li>└ P20 to P27</li> </ul>	Selectable per pin (P20 and P12 to P17 must be set to without pull-up resistor when they are used as LCD outputs.)	Can be set per pin	Fixed to without pull-up resistor
2	Power-on reset <ul style="list-style-type: none"> <li>┌ With power-on reset</li> <li>└ Without power-on reset</li> </ul>	Fixed to with power-on reset	Setting possible	Fixed to with power-on reset
3	Main clock oscillation stabilization time selection (when operating at 8 MHz) <ul style="list-style-type: none"> <li>┌ Approx. <math>2^{18}/F_c</math> (Approx. 32.8 ms)</li> <li>┌ Approx. <math>2^{17}/F_c</math> (Approx. 16.4 ms)</li> <li>└ Approx. <math>2^{14}/F_c</math> (Approx. 2.0 ms)</li> </ul>	Selectable	Setting possible	Fixed to approx. $2^{18}/F_c$ (Approx. 32.8 ms)
4	Reset pin output <ul style="list-style-type: none"> <li>┌ With reset output</li> <li>└ Without reset output</li> </ul>	Fixed to with reset output	Setting possible	Fixed to with reset output

## ■ ORDERING INFORMATION

Part number	Package	Remarks
MB89943PF MB89945PF MB89P945PF	48-pin Plastic QFP (FPT-48P-M16)	
MB89PV940CF	48-pin Ceramic MQFP (MQP-48C-P01)	

# MB89940 Series

## PACKAGE DIMENSION

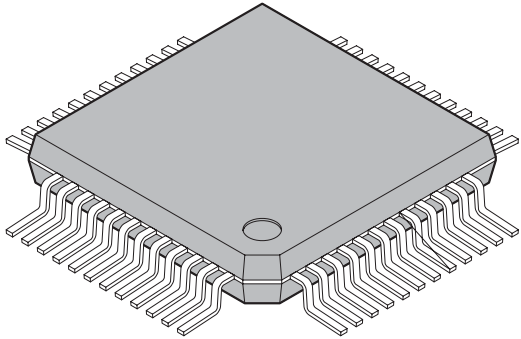
 <p>48-pin plastic QFP</p> <p>(FPT-48P-M16)</p>	Lead pitch	0.80 mm
	Package width × package length	12 × 12 mm
	Lead shape	Gullwing
	Sealing method	Plastic mold
	Mounting height	2.70 mm MAX
	Code (Reference)	P-QFP48-12×12-0.80

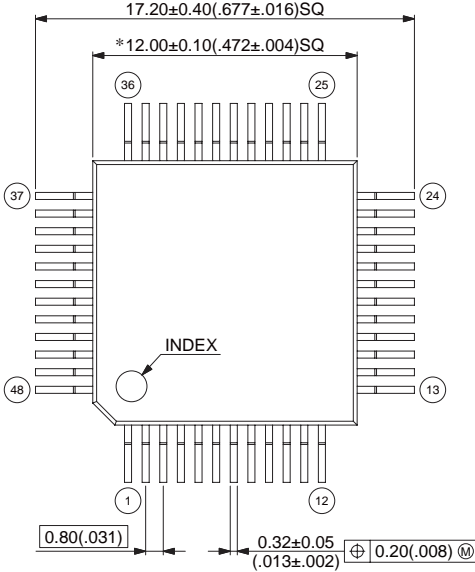
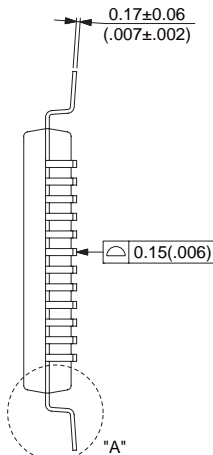
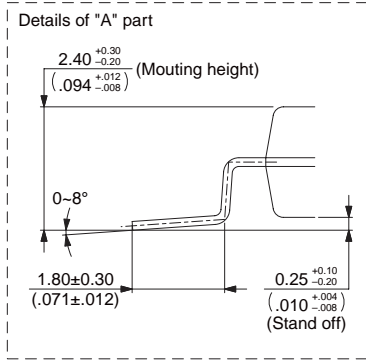
<p>48-pin plastic QFP (FPT-48P-M16)</p>	<p>Note 1) * : These dimensions do not include resin protrusion.          Note 2) Pins width and pins thickness include plating thickness.          Note 3) Pins width do not include tie bar cutting remainder.</p>
	
	
<p>© 2003-2008 FUJITSU MICROELECTRONICS LIMITED F48026S-c-3-5</p>	<p>Dimensions in mm (inches).          Note: The values in parentheses are reference values.</p>

Please confirm the latest Package dimension by following URL.  
<http://edevice.fujitsu.com/package/en-search/>

(Continued)

# MB89940 Series

(Continued)

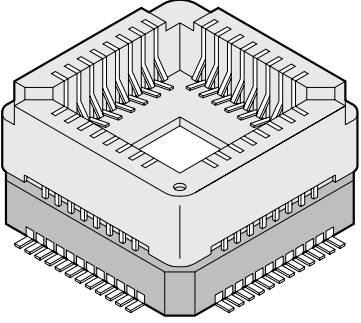
<p style="text-align: center;">48-pin ceramic MQFP</p>  <p style="text-align: center;">(MQP-48C-P01)</p>	Lead pitch	0.8 mm	
	Lead shape	Straight	
	Motherboard material	Ceramic	
	Mounted package material	Plastic	

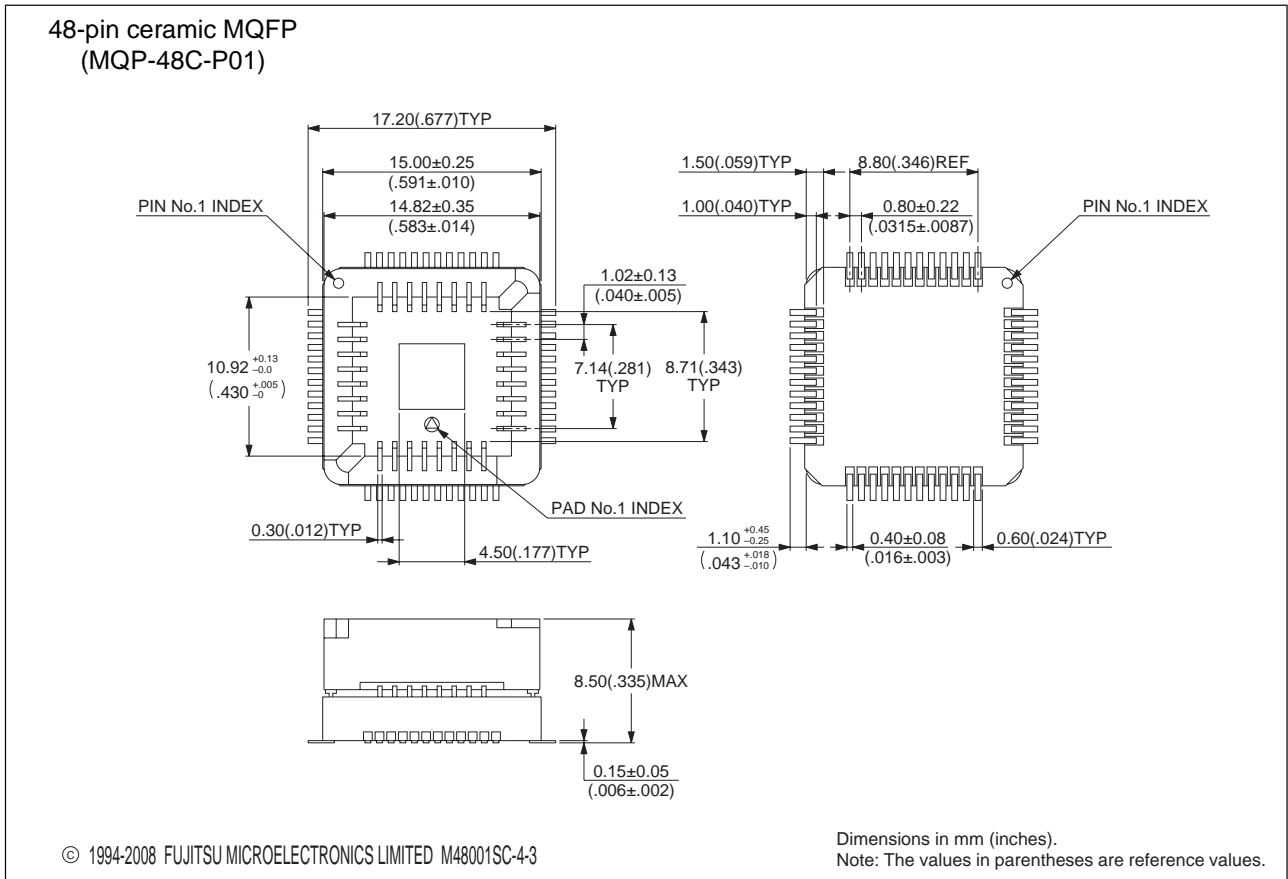

Please confirm the latest Package dimension by following URL.  
<http://edevice.fujitsu.com/package/en-search/>

# MB89940 Series

## ■ MAIN CHANGES IN THIS EDITION

Page	Section	Change Results
13	■ PROGRAMMING TO THE EPROM ON THE MB89P945	Deleted the “3. EPROM Programmer Socket Adapter”
15	■ PROGRAMMING TO THE EPROM WITH PIGGYBACK/EVALUATION DEVICE	Deleted the “2. Programming Socket Adapter”

The vertical lines marked in the left side of the page show the changes.

**MEMO**

# MB89940 Series

## FUJITSU MICROELECTRONICS LIMITED

Shinjuku Dai-Ichi Seimei Bldg., 7-1, Nishishinjuku 2-chome,  
Shinjuku-ku, Tokyo 163-0722, Japan  
Tel: +81-3-5322-3347 Fax: +81-3-5322-3387  
<http://jp.fujitsu.com/fml/en/>

*For further information please contact:*

### North and South America

FUJITSU MICROELECTRONICS AMERICA, INC.  
1250 E. Arques Avenue, M/S 333  
Sunnyvale, CA 94085-5401, U.S.A.  
Tel: +1-408-737-5600 Fax: +1-408-737-5999  
<http://www.fma.fujitsu.com/>

### Asia Pacific

FUJITSU MICROELECTRONICS ASIA PTE. LTD.  
151 Lorong Chuan,  
#05-08 New Tech Park 556741 Singapore  
Tel : +65-6281-0770 Fax : +65-6281-0220  
<http://www.fmal.fujitsu.com/>

### Europe

FUJITSU MICROELECTRONICS EUROPE GmbH  
Pittlerstrasse 47, 63225 Langen, Germany  
Tel: +49-6103-690-0 Fax: +49-6103-690-122  
<http://emea.fujitsu.com/microelectronics/>

### FUJITSU MICROELECTRONICS SHANGHAI CO., LTD.

Rm. 3102, Bund Center, No.222 Yan An Road (E),  
Shanghai 200002, China  
Tel : +86-21-6146-3688 Fax : +86-21-6335-1605  
<http://cn.fujitsu.com/fmc/>

### Korea

FUJITSU MICROELECTRONICS KOREA LTD.  
206 Kosmo Tower Building, 1002 Daechi-Dong,  
Gangnam-Gu, Seoul 135-280, Republic of Korea  
Tel: +82-2-3484-7100 Fax: +82-2-3484-7111  
<http://kr.fujitsu.com/fmk/>

### FUJITSU MICROELECTRONICS PACIFIC ASIA LTD.

10/F., World Commerce Centre, 11 Canton Road,  
Tsimshatsui, Kowloon, Hong Kong  
Tel : +852-2377-0226 Fax : +852-2376-3269  
<http://cn.fujitsu.com/fmc/en/>

Specifications are subject to change without notice. For further information please contact each office.

### All Rights Reserved.

The contents of this document are subject to change without notice.

Customers are advised to consult with sales representatives before ordering.

The information, such as descriptions of function and application circuit examples, in this document are presented solely for the purpose of reference to show examples of operations and uses of FUJITSU MICROELECTRONICS device; FUJITSU MICROELECTRONICS does not warrant proper operation of the device with respect to use based on such information. When you develop equipment incorporating the device based on such information, you must assume any responsibility arising out of such use of the information.

FUJITSU MICROELECTRONICS assumes no liability for any damages whatsoever arising out of the use of the information.

Any information in this document, including descriptions of function and schematic diagrams, shall not be construed as license of the use or exercise of any intellectual property right, such as patent right or copyright, or any other right of FUJITSU MICROELECTRONICS or any third party or does FUJITSU MICROELECTRONICS warrant non-infringement of any third-party's intellectual property right or other right by using such information. FUJITSU MICROELECTRONICS assumes no liability for any infringement of the intellectual property rights or other rights of third parties which would result from the use of information contained herein.

The products described in this document are designed, developed and manufactured as contemplated for general use, including without limitation, ordinary industrial use, general office use, personal use, and household use, but are not designed, developed and manufactured as contemplated (1) for use accompanying fatal risks or dangers that, unless extremely high safety is secured, could have a serious effect to the public, and could lead directly to death, personal injury, severe physical damage or other loss (i.e., nuclear reaction control in nuclear facility, aircraft flight control, air traffic control, mass transport control, medical life support system, missile launch control in weapon system), or (2) for use requiring extremely high reliability (i.e., submersible repeater and artificial satellite).

Please note that FUJITSU MICROELECTRONICS will not be liable against you and/or any third party for any claims or damages arising in connection with above-mentioned uses of the products.

Any semiconductor devices have an inherent chance of failure. You must protect against injury, damage or loss from such failures by incorporating safety design measures into your facility and equipment such as redundancy, fire protection, and prevention of over-current levels and other abnormal operating conditions.

Exportation/release of any products described in this document may require necessary procedures in accordance with the regulations of the Foreign Exchange and Foreign Trade Control Law of Japan and/or US export control laws.

The company names and brand names herein are the trademarks or registered trademarks of their respective owners.

Edited: Business & Media Promotion Dept.