

## *8-bit Proprietary Microcontroller*

CMOS

# F<sup>2</sup>MC-8L MB89860 Series

## MB89865/867/P867/W867

### ■ DESCRIPTION

The MB89860 series has been developed as a general-purpose version of the F<sup>2</sup>MC\*-8L family consisting of proprietary 8-bit, single-chip, microcontrollers.

In addition to the F<sup>2</sup>MC-8L CPU core which can operate at low voltage but at high speed, the microcontrollers contain a variety of peripheral functions such as a timer unit, PWM timers, a UART, a serial interface, a 10-bit A/D converter, and an external interrupt.

The MB89860 series is applicable to a wide range of applications from welfare products to industrial equipment, including portable devices.

\*: F<sup>2</sup>MC is the abbreviation of FUJITSU Flexible Microcontroller.

### ■ FEATURES

- Various package options  
QFP package (80 pins): MB89860
- High-speed processing at low voltage  
Minimum execution time: 0.4 μs/3.5 V, 0.8 μs/2.7 V

*(Continued)*

For the information for microcontroller supports, see the following web site.

<http://edevic.fujitsu.com/micom/en-support/>

# MB89860 Series

(Continued)

- F<sup>2</sup>MC-8L family CPU core

Instruction set optimized for controllers

Multiplication and division instructions  
16-bit arithmetic operations  
Test and branch instructions  
Bit manipulation instructions, etc.

- 8-bit PWM timers: 2 channels  
Also usable as a reload timer
- UART  
Full-duplex double buffer  
Synchronous and asynchronous data transfer
- 8-bit serial I/O  
Switchable transfer direction allows communication with various equipment.
- 10-bit A/D converter  
Conversion time: 13.2  $\mu$ s  
Activation by an external input or a timer unit capable
- External interrupt: 4 channels  
Four channels are independent and capable of wake-up from low-power consumption modes (with an edge detection function).
- Low-power consumption modes  
Stop mode (Oscillation stops to minimize the current consumption.)  
Sleep mode (The CPU stops to reduce the current consumption to approx. 1/3 of normal.)
- Bus interface functions  
Including hold and ready functions
- Timer unit  
Outputs non-overlap three-phase waveforms to control an AC inverter motor.  
Also usable as a PWM timer (4 channels)

# MB89860 Series

## ■ PRODUCT LINEUP

Part number Parameter	MB89865	MB89867	MB89P867 MB89W867
Classification	Mass production products (mask ROM products)		One-time PROM products/ EPROM products, also used for evaluation
ROM size	16 K × 8 bits (internal mask ROM)	32 K × 8 bits (internal mask ROM)	32 K × 8 bits (internal PROM, programming with general-purpose EPROM programmer)
RAM size	512 × 8 bits	1 K × 8 bits	
CPU functions	Number of instructions: 136 Instruction bit length: 8 bits Instruction length: 1 to 3 bytes Data bit length: 1, 8, 16 bits Minimum execution time: 0.4 μs/10 MHz Interrupt processing time: 3.6 μs/10 MHz		
Ports	Input ports: 5 (All also serve as peripherals) Output ports (N-ch open drain): 8 (All also serve as peripherals) I/O ports (N-ch open drain): 15 Output ports (CMOS): 8 (All also serve as bus control pins) I/O ports (CMOS): 32 (All also serve as bus pins or peripherals) Total: 68		
Timer unit	10-bit up/down count timer × 1 Compare registers with buffer × 4 Compare timer unit clear register with buffer × 1 Zero detection pin control 4 output channels Non-overlap three-phase waveform output Independent three-phase dead-time timer		
8-bit PWM timer 1, 8-bit PWM timer 2	8-bit reload timer operation (toggled output capable, operating clock cycle: 0.4 μs to 25.6 μs) 8-bit resolution PWM operation (conversion cycle: 102 μs to 6.528 ms)		
UART	8 bits Clock synchronous/asynchronous data transfer capable		
8-bit serial I/O	8 bits LSB first/MSB first selectability One clock selectable from four transfer clocks (one external shift clock, three internal shift clocks: 0.8 μs, 3.2 μs, 12.8 μs)		
10-bit A/D converter	10-bit resolution × 8 channels A/D conversion time: 13.2 μs Continuous activation by a compare channel 0 in timer unit or an external activation capable		
External interrupt	4 independent channels (edge selection, interrupt vector, source flag) Rising edge/falling edge selectability. Used also for wake-up from stop/sleep mode. (Edge detection is also permitted in stop mode.)		
Standby modes	Sleep mode, stop mode		
Process	CMOS		
Operating voltage*	2.7 V to 6.0 V		2.7 V to 5.5 V

\* : Varies with conditions such as the operating frequency. (See section “■ Electrical Characteristics”.)

# MB89860 Series

## ■ PACKAGE AND CORRESPONDING PRODUCTS

Package	MB89865	MB89867	MB89P867	MB89W867
FPT-80P-M06	○	○	○	×
FPT-80C-A02	×	×	×	○

○ : Available    × : Not available

Note: For more information about each package, see section “■ Package Dimensions”.

## ■ DIFFERENCES AMONG PRODUCTS

### 1. Memory Size

Before evaluating using the OTPROM (one-time PROM) products (also used for evaluation), verify its differences from the product that will actually be used.

Take particular care on the following point:

- The stack area, etc., is set at the upper limit of the RAM.

### 2. Current Consumption

When operated at low speed, the product with an OTPROM or an EPROM will consume more current than the product with a mask ROM.

However, the current consumption in sleep/stop modes is the same.

### 3. Mask Options

In the MB89P867/W867, no option can be set.

Before using options check section “■ Mask Options”.

Take particular care on the following point:

- A pull-up resistor can be set for P00 to P07, P10 to P17 and P20 to P27 only at single-chip mode.

## ■ PIN ASSIGNMENT

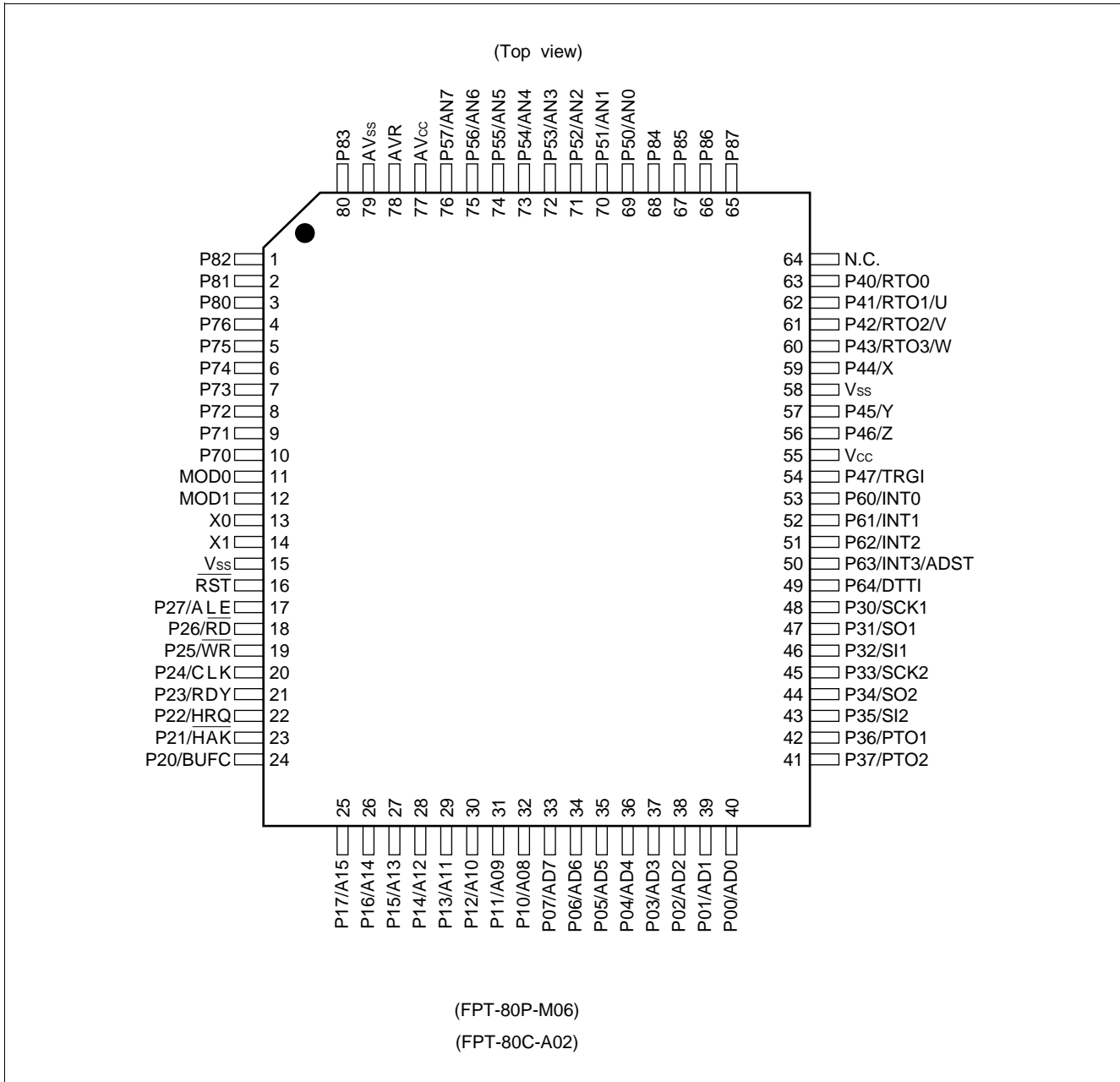

# MB89860 Series

## ■ PIN DESCRIPTION

Pin no.	Pin name	Circuit type	Function
QFP*			
13	X0	A	Crystal oscillator pins (10 MHz)
14	X1		
11	MOD0	B	Operating mode selection pins Connect directly to V <sub>CC</sub> or V <sub>SS</sub> .
12	MOD1		
16	$\overline{\text{RST}}$	C	Reset I/O pin This pin is an N-ch open-drain output type with a pull-up resistor, and a hysteresis input type. "L" is output from this pin by an internal reset source. The internal circuit is initialized by the input of "L".
40 to 33	P00 /AD0 to P07/AD7	D	General-purpose I/O ports When an external bus is used, these ports function as multiplex pins of lower address output and data I/O.
32 to 25	P10 /A08 to P17/A15	D	General-purpose I/O ports When an external bus is used, these ports function as upper address output.
24	P20/BUFC	F	General-purpose output port When an external bus is used, this port can also be used as a buffer control output.
23	P21/ $\overline{\text{HAK}}$	F	General-purpose output port When an external bus is used, this port can also be used as a hold acknowledge output.
22	P22/HRQ	D	General-purpose output port When an external bus is used, this port can also be used as a hold request input.
21	P23/RDY	D	General-purpose output port When an external bus is used, this port functions as a ready input.
20	P24/CLK	F	General-purpose output port When an external bus is used, this port functions as a clock output.
19	P25/ $\overline{\text{WR}}$	F	General-purpose output port When an external bus is used, this port functions as a write signal output.
18	P26/ $\overline{\text{RD}}$	F	General-purpose output port When an external bus is used, this port functions as a read signal output.
17	P27/ALE	F	General-purpose output port When an external bus is used, this port functions as an address latch signal output.
48	P30/SCK1	E	General-purpose I/O port Also serves as the clock I/O for the UART. This port is a hysteresis input type.

\* : FPT-80P-M06, FPT-80C-A02

(Continued)

# MB89860 Series

Pin no. QFP*	Pin name	Circuit type	Function
47	P31/SO1	E	General-purpose I/O port Also serves as the data output for the UART. This port is a hysteresis input type.
46	P32/SI1	E	General-purpose I/O port Also serves as the data input for the UART. This port is a hysteresis input type.
45	P33/SCK2	E	General-purpose I/O port Also serves as the clock I/O for the 8-bit serial I/O. This port is a hysteresis input type.
44	P34/SO2	E	General-purpose I/O port Also serves as the data output for the 8-bit serial I/O. This port is a hysteresis input type.
43	P35/SI2	E	General-purpose I/O port Also serves as the data input for the 8-bit serial I/O. This port is a hysteresis input type.
42	P36/PTO1	E	General-purpose I/O port Also serves as the pulse output for the 8-bit PWM timer 1. This port is a hysteresis input type.
41	P37/PTO2	E	General-purpose I/O port Also serves as the pulse output for the 8-bit PWM timer 2. This port is a hysteresis input type.
63	P40/RTO0	E	General-purpose I/O port Also serves as the pulse output for the timer unit. This port is a hysteresis input type.
62, 61, 60	P41/RTO1/U, P42/RTO2/V, P43/RTO3/W	E	General-purpose I/O ports Also serve as the pulse output for the timer unit or a non-overlap three-phase waveform output. These ports are a hysteresis input type.
59, 57, 56	P44/X, P45/Y, P46/Z	E	General-purpose I/O ports Also serve as a non-overlap three-phase output. These ports are a hysteresis input type.
54	P47/TRGI	E	General-purpose I/O port Also serves as the trigger input for the timer unit. This port is a hysteresis input type.
69 to 76	P50/AN0 to P57/AN7	H	N-ch open-drain output ports Also serve as the analog input for the A/D converter.
53 to 51	P60/INT0 to P62/INT2	I	General-purpose input ports Also serve as an external interrupt input. These ports are a hysteresis input type.
50	P63/INT3/ ADST	I	General-purpose input port Also serves as an external interrupt input and as the activation trigger input for the A/D converter. This port is a hysteresis input type.

\* : FPT-80P-M06, FPT-80C-A02

(Continued)

# MB89860 Series

(Continued)

Pin no. QFP*	Pin name	Circuit type	Function
49	P64/DTTI	I	General-purpose input port Also serves as a dead-time timer disable input. This port is a hysteresis input type. DTTI input is with a noise canceller.
10 to 4	P70 to P76	G	N-ch open-drain I/O ports These ports are a hysteresis input type.
3 to 1, 80, 68 to 65	P80 to P87	G	N-ch open-drain I/O ports These ports are a hysteresis input type.
55	V <sub>cc</sub>	—	Power supply pin
15, 58	V <sub>ss</sub>	—	Power supply (GND) pins
77	AV <sub>cc</sub>	—	A/D converter power supply pin
78	AVR	—	A/D converter reference voltage input pin
79	AV <sub>ss</sub>	—	A/D converter power supply (GND) pin Use this pin at the same voltage as V <sub>ss</sub> .
64	N.C.	—	Internally connected pin Be sure to leave it open.

\* : FPT-80P-M06, FPT-80C-A02

## ■ I/O CIRCUIT TYPE

Type	Circuit	Remarks
A	<p>Standby control signal</p>	<ul style="list-style-type: none"> <li>At an oscillation feedback resistor of approximately 1 MΩ/5.0 V</li> </ul>
B		
C		<ul style="list-style-type: none"> <li>At an output pull-up resistor (P-ch) of approximately 50 kΩ/5.0 V</li> <li>Hysteresis input</li> </ul>
D		<ul style="list-style-type: none"> <li>CMOS output</li> <li>CMOS input</li> <li>Pull-up resistor optional (Mask ROM products)</li> <li>At a pull-up resistor of approximately 50 kΩ/5.0 V</li> </ul>
E		<ul style="list-style-type: none"> <li>CMOS output</li> <li>Hysteresis input</li> <li>Pull-up resistor optional (Mask ROM products)</li> <li>At a pull-up resistor of approximately 50 kΩ/5.0 V</li> </ul>

(Continued)

# MB89860 Series

(Continued)

Type	Circuit	Remarks
F		<ul style="list-style-type: none"> <li>• CMOS output</li> <li>• Pull-up resistor optional (Mask ROM products)</li> <li>• At a pull-up resistor of approximately 50 kΩ/5.0 V</li> </ul>
G		<ul style="list-style-type: none"> <li>• N-ch open-drain output</li> <li>• Hysteresis input</li> <li>• Pull-up resistor optional (Mask ROM products)</li> <li>• At a pull-up resistor of approximately 50 kΩ/5.0 V</li> </ul>
H		<ul style="list-style-type: none"> <li>• N-ch open-drain output</li> <li>• Analog input</li> </ul>
I		<ul style="list-style-type: none"> <li>• Hysteresis input</li> <li>• Pull-up resistor optional (Mask ROM products)</li> <li>• At a pull-up resistor of approximately 50 kΩ/5.0 V</li> </ul>

## ■ HANDLING DEVICES

### 1. Preventing Latchup

Latchup may occur on CMOS ICs if voltage higher than  $V_{CC}$  or lower than  $V_{SS}$  is applied to input and output pins other than medium- to high-voltage pins or if higher than the voltage which shows on “1. Absolute Maximum Ratings” in section “■ Electrical Characteristics” is applied between  $V_{CC}$  and  $V_{SS}$ .

When latchup occurs, power supply current increases rapidly and might thermally damage elements. When using, take great care not to exceed the absolute maximum ratings.

Also, take care to prevent the analog power supply ( $AV_{CC}$  and  $AVR$ ) and analog input from exceeding the digital power supply ( $V_{CC}$ ) when the analog system power supply is turned on and off.

### 2. Treatment of Unused Input Pins

Leaving unused input pins open could cause malfunctions. They should be connected to a pull-up or pull-down resistor.

### 3. Treatment of Power Supply Pins on Microcontrollers with A/D and D/A Converters

Connect to be  $AV_{CC} = DAVC = V_{CC}$  and  $AV_{SS} = AVR = V_{SS}$  even if the A/D and D/A converters are not in use.

### 4. Treatment of N.C. Pin

Be sure to leave (internally connected) N.C. pin open.

### 5. Power Supply Voltage Fluctuations

Although  $V_{CC}$  power supply voltage is assured to operate within the rated range, a rapid fluctuation of the voltage could cause malfunctions, even if it occurs within the rated range. Stabilizing voltage supplied to the IC is therefore important. As stabilization guidelines, it is recommended to control power so that  $V_{CC}$  ripple fluctuations (P-P value) will be less than 10% of the standard  $V_{CC}$  value at the commercial frequency (50 to 60 Hz) and the transient fluctuation rate will be less than 0.1 V/ms at the time of a momentary fluctuation such as when power is switched.

### 6. Precautions when Using an External Clock

Even when an external clock is used, oscillation stabilization time is required for power-on reset (optional) and wake-up from stop mode.

# MB89860 Series

## ■ PROGRAMMING TO THE EPROM ON THE MB89P867/W867

The MB89P867/W867 are an OTPROM version of the MB89860 series.

### 1. Features

- 32-Kbyte PROM on chip
- Equivalency to the MBM27C256A in EPROM mode (when programmed with the EPROM programmer)

### 2. Memory Space

Memory space in EPROM mode is diagrammed below.

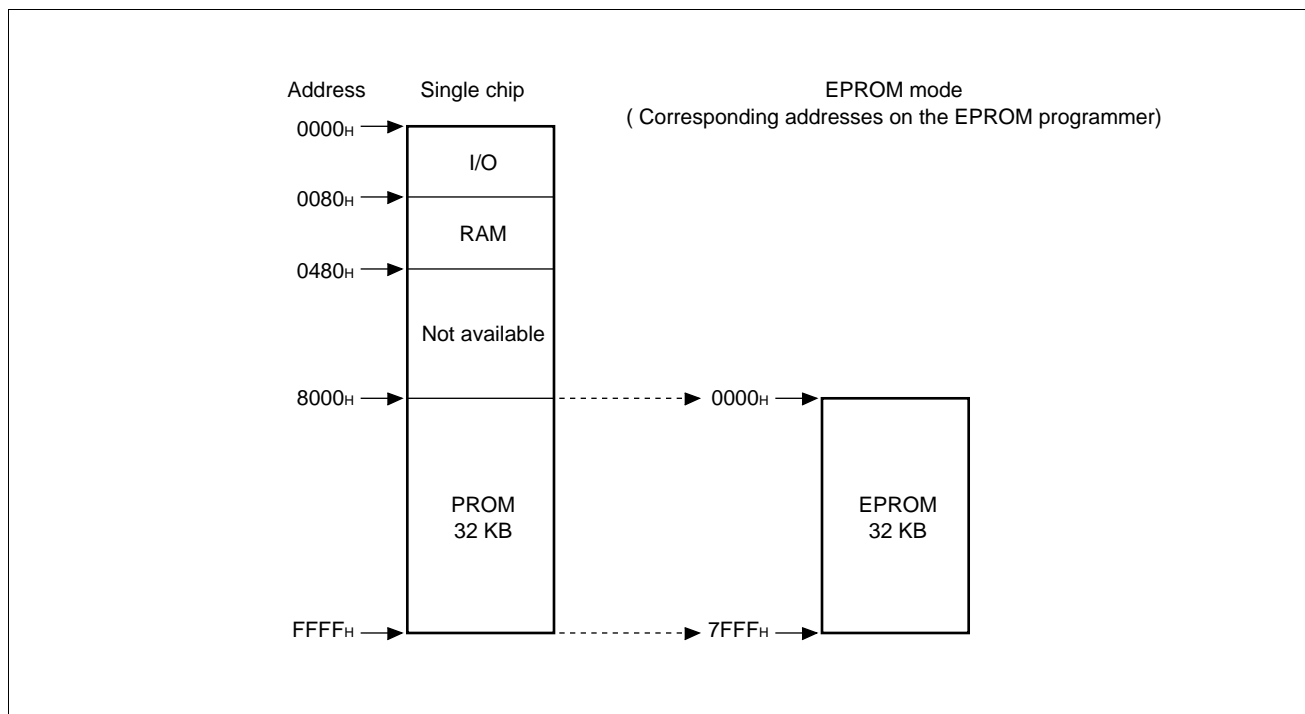

### 3. Programming to the EPROM

In EPROM mode, the MB89P867/W867 functions equivalent to the MBM27C256A. This allows the PROM to be programmed with a general-purpose EPROM programmer (the electronic signature mode cannot be used) by using the dedicated socket adapter.

#### • Programming procedure

- (1) Set the EPROM programmer to the MBM27C256A.
- (2) Load program data into the EPROM programmer at 0000H to 7FFFH (note that addresses 8000H to FFFFH while operating as a single chip assign to addresses 0000H to 7FFFH in EPROM mode.)
- (3) Program to 0000H to 7FFFH with the EPROM programmer.

## 4. Recommended Screening Conditions

High-temperature aging is recommended as the pre-assembly screening procedure for a product with a blanked OTPROM microcomputer program.

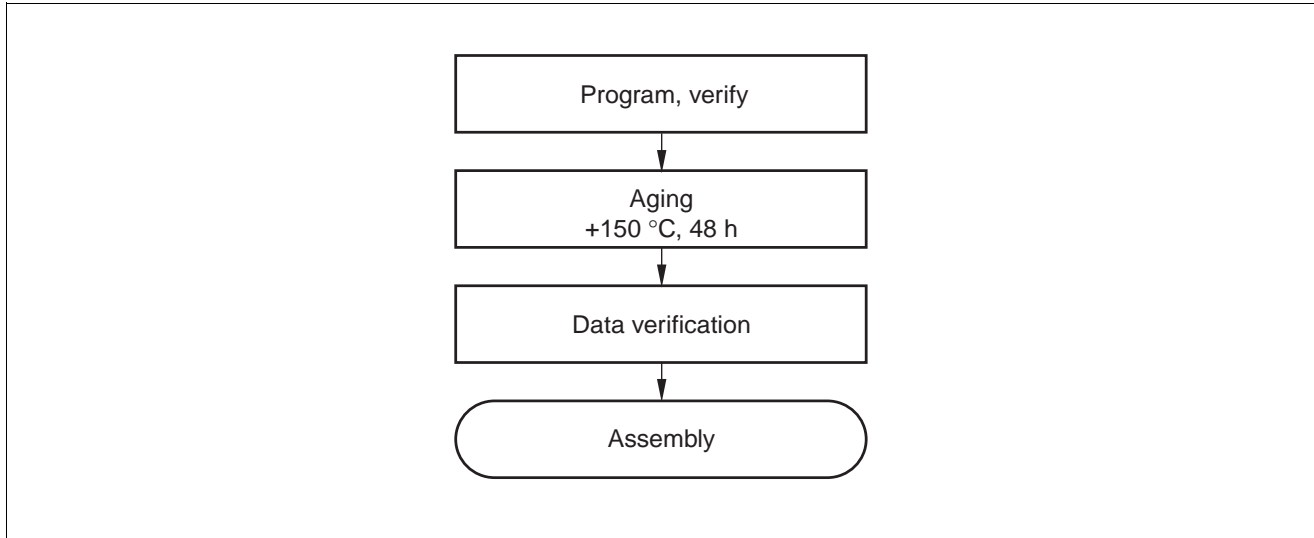

## 5. Programming Yield

All bits cannot be programmed at Fujitsu shipping test to a blanked OTPROM microcomputer, due to its nature. For this reason, a programming yield of 100% cannot be assured at all times.

## 6. Erasure

In order to clear all locations of their programmed contents, it is necessary to expose the internal EPROM to an ultraviolet light source. A dosage of 10 W-seconds/cm<sup>2</sup> is required to completely erase an internal EPROM. This dosage can be obtained by exposure to an ultraviolet lamp (wavelength of 2537 Angstroms (Å)) with intensity of 12000 μW/cm<sup>2</sup> for 15 to 21 minutes. The internal EPROM should be about one inch from the source and all filters should be removed from the UV light source prior to erasure.

It is important to note that the internal EPROM and similar devices, will erase with light sources having wavelengths shorter than 4000 Å. Although erasure time will be much longer than with UV source at 2537 Å, nevertheless the exposure to fluorescent light and sunlight will eventually erase the internal EPROM, and exposure to them should be prevented to realize maximum system reliability. If used in such an environment, the package windows should be covered by an opaque label or substance.

# MB89860 Series

## ■ BLOCK DIAGRAM

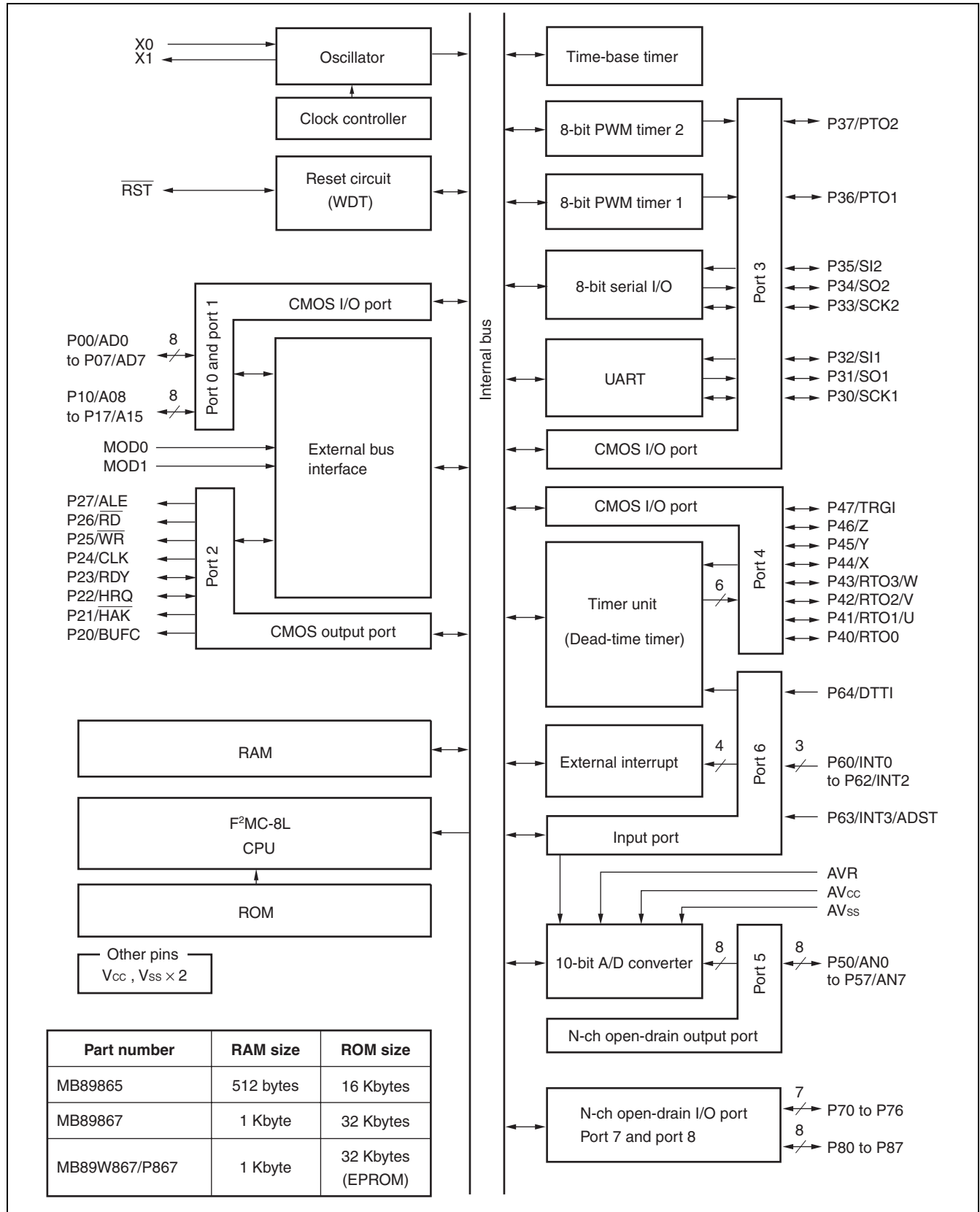

## ■ CPU CORE

### 1. Memory Space

The microcontrollers of the MB89860 series offer a memory space of 64 Kbytes for storing all of I/O, data, and program areas. The I/O area is located at the lowest address. The data area is provided immediately above the I/O area. The data area can be divided into register, stack, and direct areas according to the application. The program area is located at exactly the opposite end, that is, near the highest address. Provide the tables of interrupt reset vectors and vector call instructions toward the highest address within the program area. The memory space of the MB89860 series is structured as illustrated below.

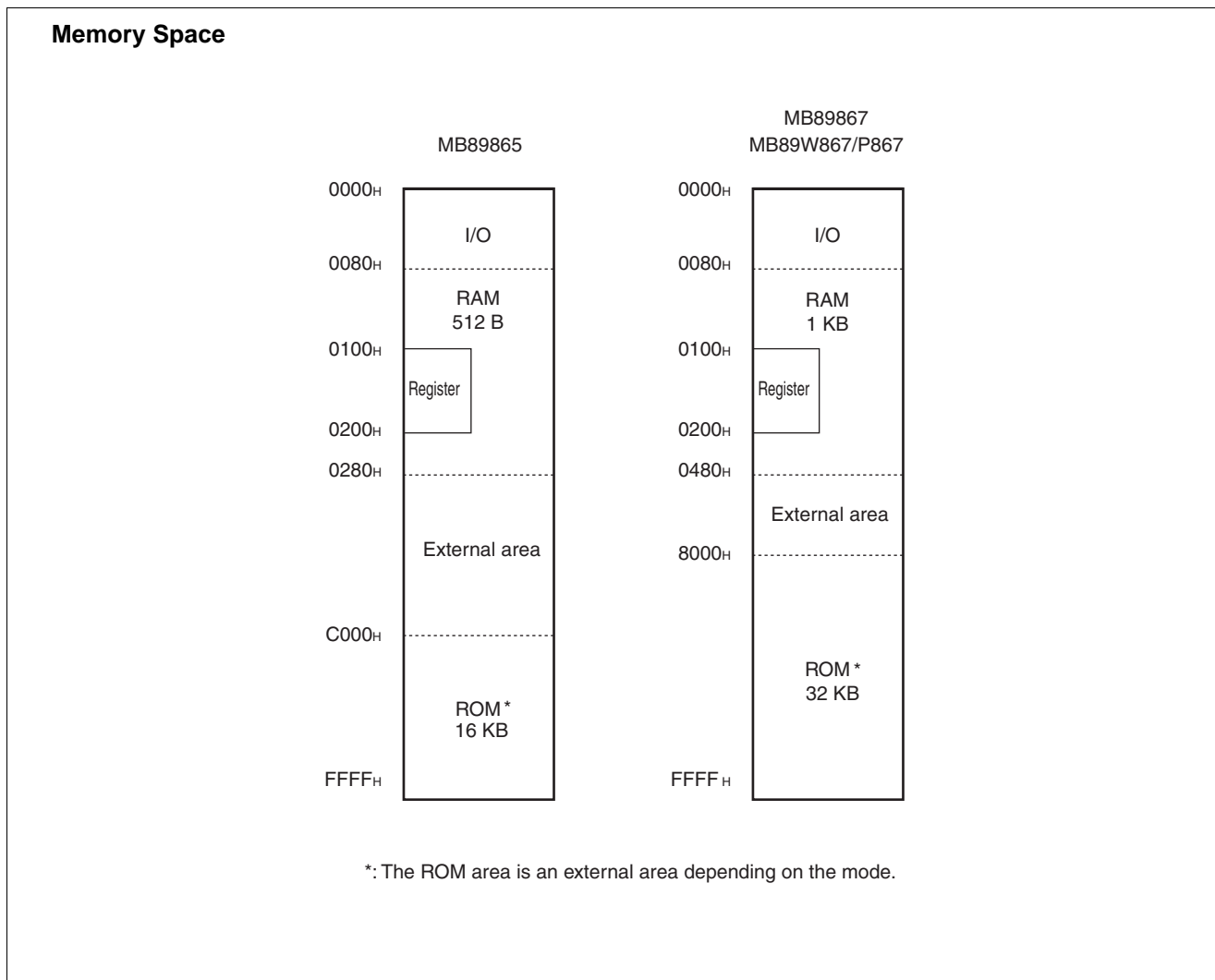

# MB89860 Series

## 2. Registers

The F<sup>2</sup>MC-8L family has two types of registers; dedicated registers in the CPU and general-purpose registers in the memory. The following dedicated registers are provided:

- Program counter (PC):           A 16-bit register for indicating instruction storage positions
- Accumulator (A):                A 16-bit temporary register for storing arithmetic operations, etc. When the instruction is an 8-bit data processing instruction, the lower byte is used.
- Temporary accumulator (T):    A 16-bit register which performs arithmetic operations with the accumulator  
When the instruction is an 8-bit data processing instruction, the lower byte is used.
- Index register (IX):            A 16-bit register for index modification
- Extra pointer (EP):             A 16-bit pointer for indicating a memory address
- Stack pointer (SP):             A 16-bit register for indicating a stack area
- Program status (PS):            A 16-bit register for storing a register pointer, a condition code

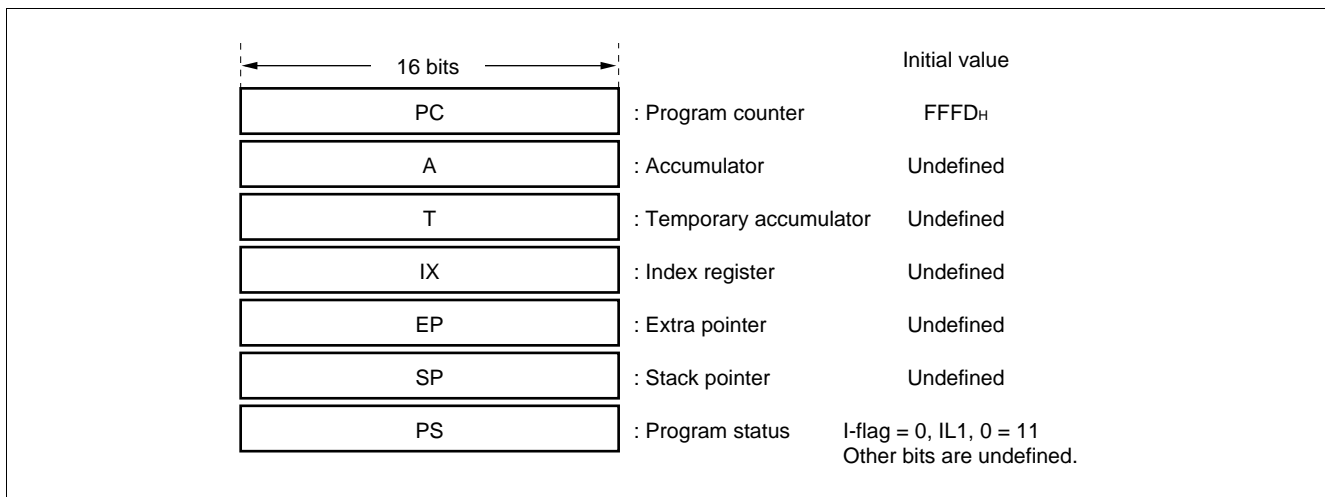

The PS can further be divided into higher 8 bits for use as a register bank pointer (RP) and the lower 8 bits for use as a condition code register (CCR). (See the diagram below.)

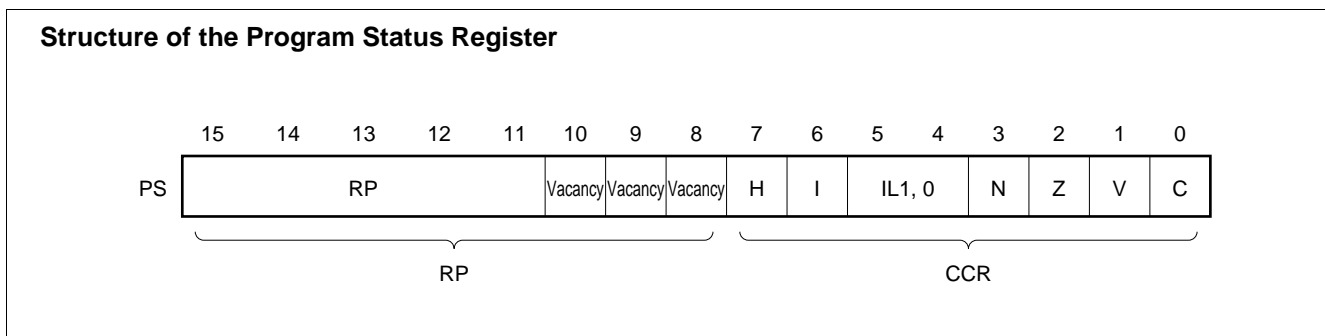

The RP indicates the address of the register bank currently in use. The relationship between the pointer contents and the actual address is based on the conversion rule illustrated below.

## Rule for Conversion of Actual Addresses of the General-purpose Register Area

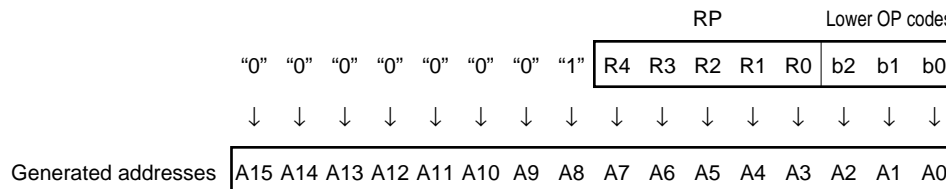

The CCR consists of bits indicating the results of arithmetic operations and the contents of transfer data and bits for control of CPU operations at the time of an interrupt.

**H-flag:** Set when a carry or a borrow from bit 3 to bit 4 occurs as a result of an arithmetic operation. Cleared otherwise. This flag is for decimal adjustment instructions.

**I-flag:** Interrupt is allowed when this flag is set to 1. Interrupt is prohibited when the flag is set to 0. Set to 0 when reset.

**IL1, 0:** Indicates the level of the interrupt currently allowed. Processes an interrupt only if its request level is higher than the value indicated by this bit.

IL1	ILO	Interrupt level	High-low
0	0	1	High ↑ ↓ Low = no interrupt
0	1		
1	0	2	
1	1	3	

**N-flag:** Set if the MSB is set to 1 as the result of an arithmetic operation. Cleared when the bit is set to 0.

**Z-flag:** Set when an arithmetic operation results in 0. Cleared otherwise.

**V-flag:** Set if the complement on 2 overflows as a result of an arithmetic operation. Reset if the overflow does not occur.

**C-flag:** Set when a carry or a borrow from bit 7 occurs as a result of an arithmetic operation. Cleared otherwise. Set to the shift-out value in the case of a shift instruction.

# MB89860 Series

The following general-purpose registers are provided:

General-purpose registers: An 8-bit register for storing data

The general-purpose registers are 8 bits and located in the register banks of the memory. One bank contains eight registers and up to a total of 32 banks can be used on the MB89860 series. The bank currently in use is indicated by the register bank pointer (RP).

Note: The number of register banks that can be used varies with the RAM size.

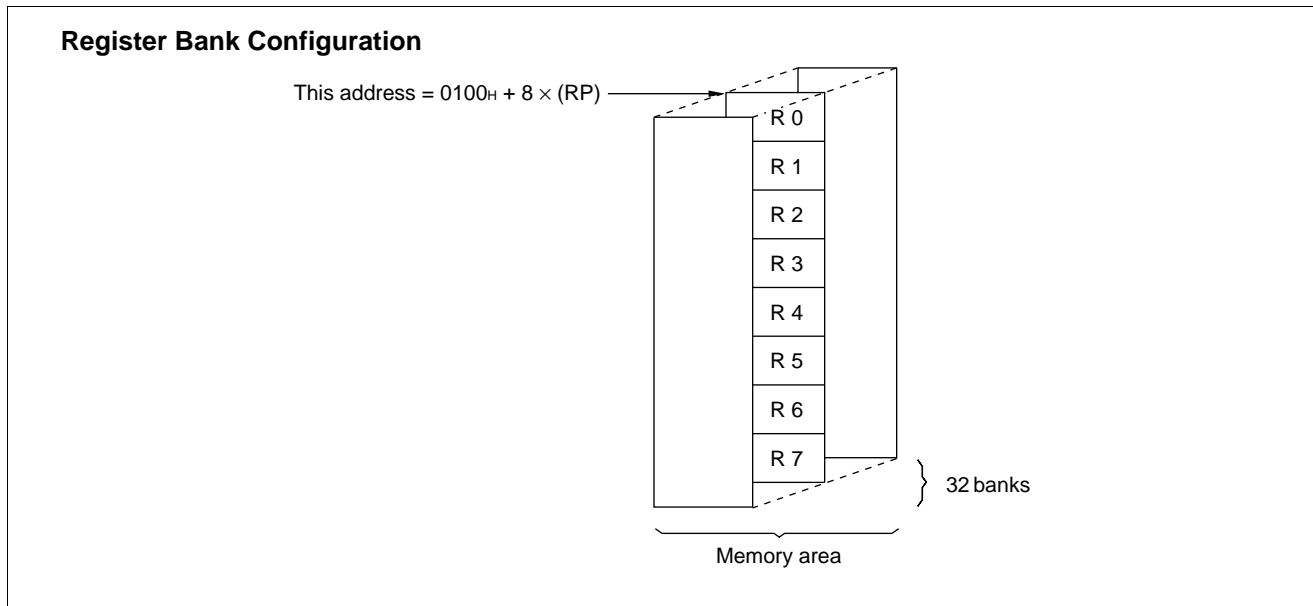

## ■ I/O MAP

Address	Read/write	Register name	Register description
00 <sub>H</sub>	(R/W)	PDR0	Port 0 data register
01 <sub>H</sub>	(W)	DDR0	Port 0 data direction register
02 <sub>H</sub>	(R/W)	PDR1	Port 1 data register
03 <sub>H</sub>	(W)	DDR1	Port 1 data direction register
04 <sub>H</sub>	(R/W)	PDR2	Port 2 data register
05 <sub>H</sub>	(W)	BCTR	External bus pin control register
06 <sub>H</sub>			Vacancy
07 <sub>H</sub>			Vacancy
08 <sub>H</sub>	(R/W)	STBC	Standby control register
09 <sub>H</sub>	(W)	WDTC	Watchdog timer control register
0A <sub>H</sub>	(R/W)	TBTC	Time-base timer control register
0B <sub>H</sub>			Vacancy
0C <sub>H</sub>	(R/W)	PDR3	Port 3 data register
0D <sub>H</sub>	(W)	DDR3	Port 3 data direction register
0E <sub>H</sub>	(R/W)	PDR4	Port 4 data register
0F <sub>H</sub>	(W)	DDR4	Port 4 data direction register
10 <sub>H</sub>	(R/W)	PDR5	Port 5 data register
11 <sub>H</sub>			Vacancy
12 <sub>H</sub>	(R)	PDR6	Port 6 data register
13 <sub>H</sub>			Vacancy
14 <sub>H</sub>	(R/W)	PDR7	Port 7 data register
15 <sub>H</sub>			Vacancy
16 <sub>H</sub>	(R/W)	PDR8	Port 8 data register
17 <sub>H</sub> to 1B <sub>H</sub>			Vacancy
1C <sub>H</sub>	(R/W)	CTR1	PWM control register 1
1D <sub>H</sub>	(W)	CMR1	PWM compare register 1
1E <sub>H</sub>	(R/W)	CTR2	PWM control register 2
1F <sub>H</sub>	(W)	CMR2	PWM compare register 2
20 <sub>H</sub>	(R/W)	SMC	UART serial mode control register
21 <sub>H</sub>	(R/W)	SRC	UART serial rate control register
22 <sub>H</sub>	(R/W)	SSD	UART serial status/data register
23 <sub>H</sub>	(R/W)	SIDR/SODR	UART serial data register
24 <sub>H</sub>	(R/W)	SMR	Serial mode register
25 <sub>H</sub>	(R/W)	SDR	Serial data register

(Continued)

# MB89860 Series

(Continued)

Address	Read/write	Register name	Register description
26 <sub>H</sub>	(R/W)	EIC1	External interrupt control register 1
27 <sub>H</sub>	(R/W)	EIC2	External interrupt control register 2
28 <sub>H</sub>	(R/W)	ADC1	A/D converter control register 1
29 <sub>H</sub>	(R/W)	ADC2	A/D converter control register 2
2A <sub>H</sub>	(R)	ADDH	A/D converter data register (H)
2B <sub>H</sub>	(R)	ADDL	A/D converter data register (L)
2C <sub>H</sub>			Vacancy
2D <sub>H</sub>	(W)	ZOCTR	Zero detection output control register
2E <sub>H</sub>	(W)	CLRBRH	Compare clear buffer register (H)
2F <sub>H</sub>	(W)	CLRBRL	Compare clear buffer register (L)
30 <sub>H</sub>	(R/W)	TCSR	Timer control status register
31 <sub>H</sub>	(R/W)	CICR	Compare interrupt control register
32 <sub>H</sub>	(R/W)	TMCR	Timer mode control register
33 <sub>H</sub>	(R/W)	COER	Compare/port selection register
34 <sub>H</sub>	(R/W)	CMCR	Compare buffer mode control register
35 <sub>H</sub>	(R/W)	DTCR	Dead-time timer control register
36 <sub>H</sub>	(W)	DTSR	Dead-time setting register
37 <sub>H</sub>	(R/W)	OCTBR	Output control buffer register
38 <sub>H</sub>	(W)	OCPBR0H	Output compare buffer register 0 (H)
39 <sub>H</sub>	(W)	OCPBR0L	Output compare buffer register 0 (L)
3A <sub>H</sub>	(W)	OCPBR1H	Output compare buffer register 1 (H)
3B <sub>H</sub>	(W)	OCPBR1L	Output compare buffer register 1 (L)
3C <sub>H</sub>	(W)	OCPBR2H	Output compare buffer register 2 (H)
3D <sub>H</sub>	(W)	OCPBR2L	Output compare buffer register 2 (L)
3E <sub>H</sub>	(W)	OCPBR3H	Output compare buffer register 3 (H)
3F <sub>H</sub>	(W)	OCPBR3L	Output compare buffer register 3 (L)
40 <sub>H</sub> to 7B <sub>H</sub>			Vacancy
7C <sub>H</sub>	(W)	ILR1	Interrupt level setting register 1
7D <sub>H</sub>	(W)	ILR2	Interrupt level setting register 2
7E <sub>H</sub>	(W)	ILR3	Interrupt level setting register 3
7F <sub>H</sub>			Vacancy

Notes: • Do not use vacancies.

- When a read-modify-write instruction (such as bit set) is used to access a write-only register or a register containing a write-only bit, a bit designated by the instruction will have a predetermined value. However, a write-only bit included, if any, in bits not defined by the instruction will cause a malfunction. So no access to the register should be tried with any read-modify-write instruction.

## ■ ELECTRICAL CHARACTERISTICS

### 1. Absolute Maximum Ratings

( $AV_{SS} = V_{SS} = 0.0\text{ V}$ )

Parameter	Symbol	Value		Unit	Remarks
		Min.	Max.		
Power supply voltage	$V_{CC}$ $AV_{CC}$	$V_{SS} - 0.3$	$V_{SS} + 7.0$	V	*
A/D converter reference input voltage	AVR	$V_{SS} - 0.3$	$V_{SS} + 7.0$	V	AVR must not exceed $AV_{CC} + 0.3\text{ V}$ .
Program voltage	$V_{PP}$	$V_{SS} - 0.3$	13.0	V	MOD1 pins of MB89P867/ W867
Input voltage	$V_I$	$V_{SS} - 0.3$	$V_{CC} + 0.3$	V	
Output voltage	$V_O$	$V_{SS} - 0.3$	$V_{SS} + 0.3$	V	
“L” level maximum output current	$I_{OL}$	—	20	mA	
“L” level average output current	$I_{OLAV1}$	—	4	mA	P00 to P07, P10 to P17, P20 to P27, P30 to P37, P50 to P57, P70 to P76, P80 to P87
	$I_{OLAV2}$	—	15	mA	P40 to P47
“L” level total average output current	$\Sigma I_{OLAV1}$	—	30	mA	P00 to P07, P10 to P17, P20 to P27, P30 to P37, P50 to P57, P70 to P76, P80 to P87
	$\Sigma I_{OLAV2}$	—	50	mA	P40 to P47
“H” level maximum output current	$I_{OH}$	—	-20	mA	
“H” level average output current	$I_{OHAV}$	—	-4	mA	
“H” level total maximum output current	$\Sigma I_{OH}$	—	-20	mA	
Power consumption	$P_D$	—	300	mW	
Operating temperature	$T_A$	-40	+85	°C	
Storage temperature	$T_{stg}$	-55	+150	°C	

\*: Use  $AV_{CC}$  and  $V_{CC}$  set at the same voltage.

Take care so that  $AV_{CC}$  does not exceed  $V_{CC}$ , such as when power is turned on.

**WARNING:** Semiconductor devices can be permanently damaged by application of stress (voltage, current, temperature, etc.) in excess of absolute maximum ratings. Do not exceed these ratings.

# MB89860 Series

## 2. Recommended Operating Conditions

( $V_{SS} = V_{SS} = 0.0\text{ V}$ )

Parameter	Symbol	Value		Unit	Remarks
		Min.	Max.		
Power supply voltage	$V_{CC}$ $AV_{CC}$	2.7*	6.0*	V	Normal operation assurance range* MB89867/865
		2.7*	5.5*	V	Normal operation assurance range* MB89P867/W867
		1.5	6.0	V	Retains the RAM state in stop mode
A/D converter reference input voltage	AVR	0.0	$AV_{CC}$	V	
Operating temperature	$T_A$	-40	+85	°C	

\*: These values vary with the operating frequency, instruction cycle, and analog assurance range. See Figure 1 and "5. A/D Converter Electrical Characteristics".

Note: Connect the MOD0 and MOD1 pins to  $V_{CC}$  or  $V_{SS}$ .

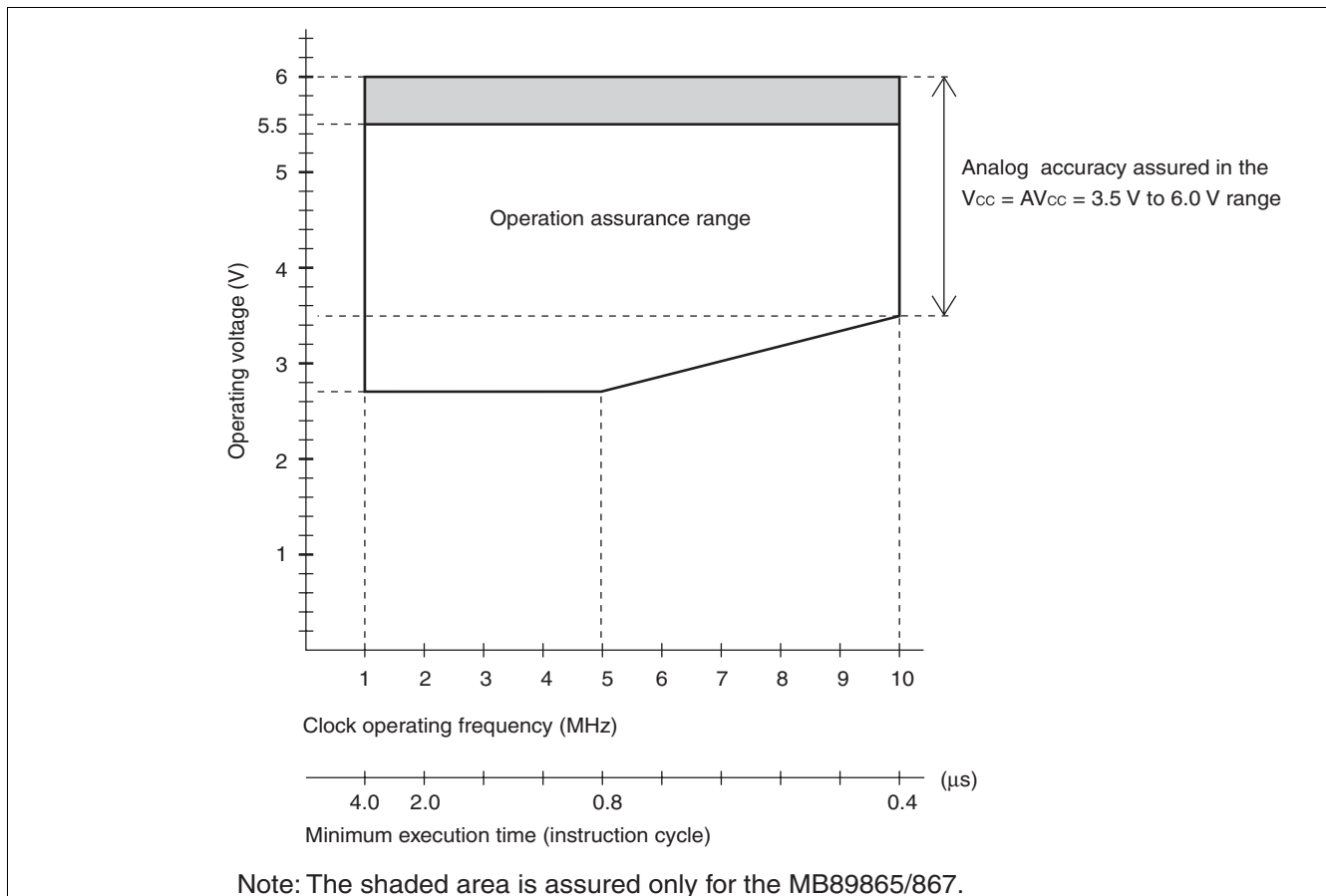

Note: The shaded area is assured only for the MB89865/867.

Figure 1 Operating Voltage vs. Clock Operating Frequency

## 3. DC Characteristics

( $AV_{CC} = V_{CC} = +5.0\text{ V}$ ,  $AV_{SS} = V_{SS} = 0.0\text{ V}$ ,  $T_A = -40^\circ\text{C}$  to  $+85^\circ\text{C}$ )

Parameter	Symbol	Pin	Condition	Value			Unit	Remarks
				Min.	Typ.	Max.		
“H” level input voltage	$V_{IH}$	P00 to P07, P10 to P17, P22, P23	—	$0.7 V_{CC}$	—	$V_{CC} + 0.3$	V	
	$V_{IHS}$	$\overline{RST}$ , P30 to P37, P40 to P47, P60 to P64, P70 to P76, P80 to P87	—	$0.8 V_{CC}$	—	$V_{CC} + 0.3$	V	
“L” level input voltage	$V_{IL}$	P00 to P07, P10 to P17, P22, P23	—	$V_{SS} - 0.3$	—	$0.3 V_{CC}$	V	
	$V_{ILS}$	$\overline{RST}$ , P30 to P37, P40 to P47, P60 to P64, P70 to P76, P80 to P87	—	$V_{SS} - 0.3$	—	$0.2 V_{CC}$	V	
“H” level output voltage	$V_{OH}$	P00 to P07, P10 to P17, P20 to P27, P30 to P37, P40 to P47	$I_{OH} = -2.0\text{ mA}$	2.4	—	—	V	
“L” level output voltage	$V_{OL1}$	P00 to P07, P10 to P17, P20 to P27, P30 to P37, P50 to P57, P70 to P76, P80 to P87	$I_{OL} = 1.8\text{ mA}$	—	—	0.4	V	
	$V_{OL2}$	P40 to P47	$I_{OL} = 15\text{ mA}$	—	—	1.5	V	
Input leakage current	$I_{LI1}$	P00 to P07, P10 to P17, P20 to P27, P30 to P37, P40 to P47, P60 to P64, P70 to P76, P80 to P87, MOD0, MOD1	$0.0\text{ V} < V_i < V_{CC}$	—	—	$\pm 5$	$\mu\text{A}$	
Pull-up resistance	$R_{PULL}$	$\overline{RST}$	$V_i = 0.0\text{ V}$	25	50	100	k $\Omega$	With pull-up resistor
Power supply current	$I_{CC}$	$V_{CC}$	$F_C = 10\text{ MHz}$	—	15	18	mA	Normal operation mode (External clock)
	$I_{CCS}$		$F_C = 10\text{ MHz}$	—	6	8	mA	Sleep mode (External clock)
	$I_{CCH}$		$T_A = +25^\circ\text{C}$	—	—	10	$\mu\text{A}$	Stop mode
	$I_A$	$AV_{CC}$	$F_C = 10\text{ MHz}$ ,	—	6	—	mA	when A/D conversion is activated
Input capacitance	$C_{IN}$	Other than $AV_{CC}$ , $AV_{SS}$ , $V_{CC}$ , and $V_{SS}$	$f = 1\text{ MHz}$	—	10	—	pF	

# MB89860 Series

## 4. AC Characteristics

### (1) Reset Timing

( $V_{CC} = +5.0\text{ V} \pm 10\%$ ,  $AV_{SS} = V_{SS} = 0.0\text{ V}$ ,  $T_A = -40^\circ\text{C}$  to  $+85^\circ\text{C}$ )

Parameter	Symbol	Condition	Value		Unit	Remarks
			Min.	Max.		
$\overline{\text{RST}}$ "L" pulse width	$t_{\text{ZLZH}}$	—	16 $t_{\text{CYL}}^*$	—	ns	

\* :  $t_{\text{CYL}}$  is the oscillation cycle ( $1/F_c$ ) to input to the X0 pin.

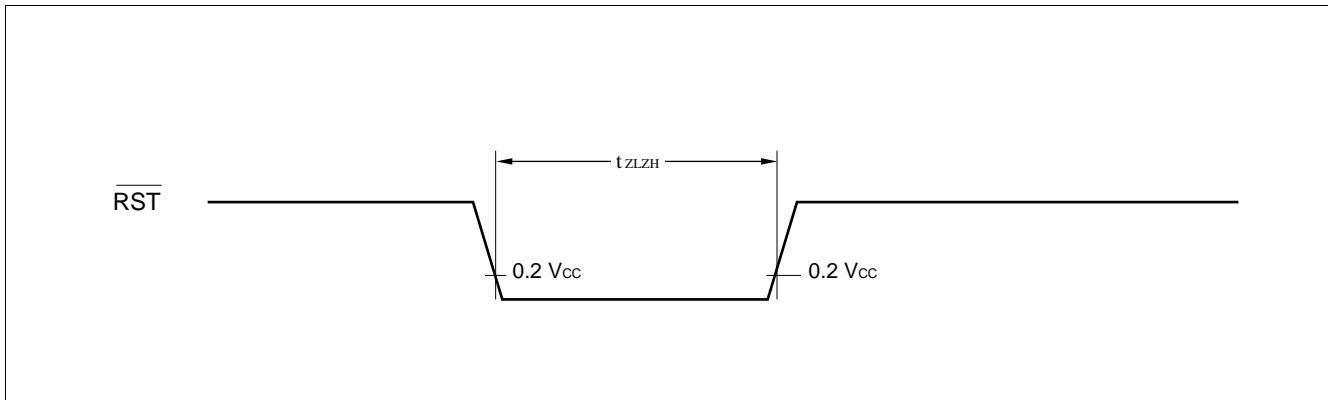

### (2) Power-on Reset

( $AV_{SS} = V_{SS} = 0.0\text{ V}$ ,  $T_A = -40^\circ\text{C}$  to  $+85^\circ\text{C}$ )

Parameter	Symbol	Condition	Value		Unit	Remarks
			Min.	Max.		
Power supply rising time	$t_{\text{R}}$	—	—	50	ms	Power-on reset function only
Power supply cut-off time	$t_{\text{OFF}}$		1	—	ms	Due to repeated operations

Note: Make sure that power supply rises within the selected oscillation stabilization time.

If power supply voltage needs to be varied in the course of operation, a smooth voltage rise is recommended.

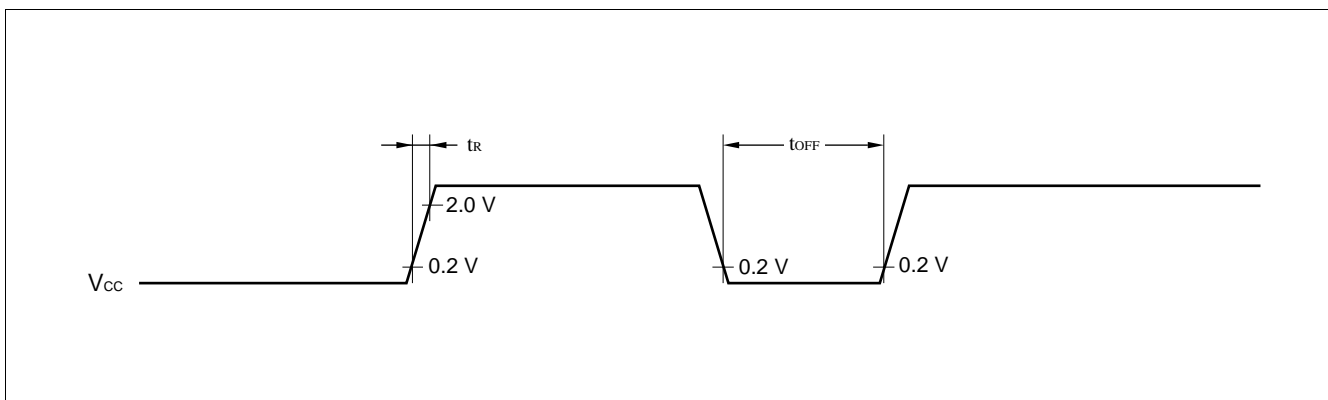

## (3) Clock Timing

( $A_{V_{SS}} = V_{SS} = 0.0 \text{ V}$ ,  $T_A = -40^\circ\text{C}$  to  $+85^\circ\text{C}$ )

Parameter	Symbol	Pin	Condition	Value		Unit	Remarks
				Min.	Max.		
Clock frequency	$F_C$	X0, X1	—	1	10	MHz	
Clock cycle time	$t_{XCYL}$			100	1000	ns	
Input clock pulse width	$P_{WH}$ $P_{WL}$	X0	—	20	—	ns	External clock
Input clock rising/falling time	$t_{CR}$ $t_{CF}$			—	10	ns	External clock

### X0 and X1 Timing Conditions

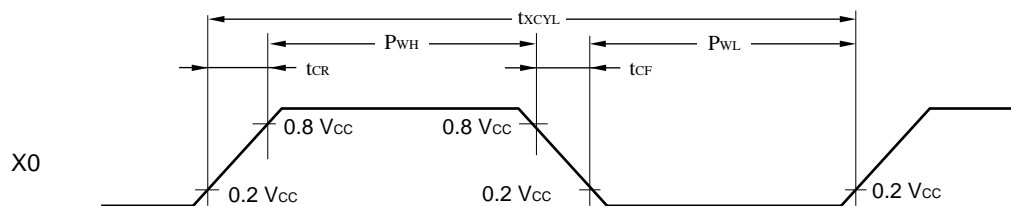

### Clock Conditions

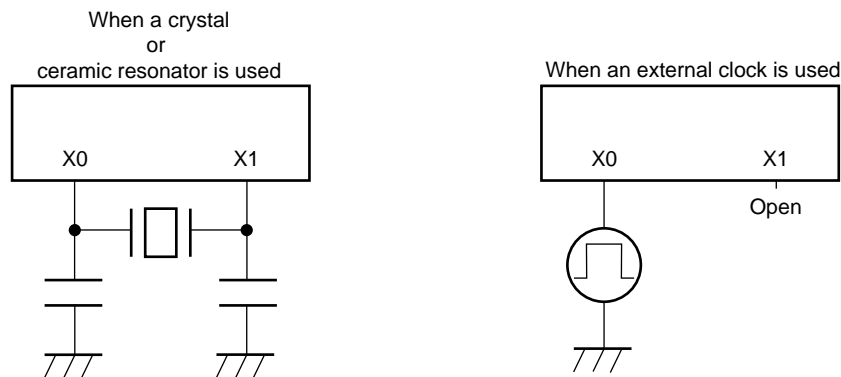

## (4) Instruction Cycle

Parameter	Symbol	Value			Unit	Remarks
		Min.	Typ.	Max.		
Instruction cycle (minimum execution time)	$t_{inst}$		$4/F_C$		$\mu\text{s}$	$t_{inst} = 0.4 \mu\text{s}$ when operating at $F_C = 10 \text{ MHz}$

# MB89860 Series

## (5) Clock Output Timing

( $V_{CC} = +5.0\text{ V} \pm 10\%$ ,  $AV_{SS} = V_{SS} = 0.0\text{ V}$ ,  $T_A = -40^\circ\text{C}$  to  $+85^\circ\text{C}$ )

Parameter	Symbol	Pin	Condition	Value		Unit	Remarks
				Min.	Max.		
Cycle time	$t_{CYC}$	CLK	Load condition: 50 pF	200	—	ns	$t_{CYCL} \times 2$ at 10 MHz oscillation
CLK $\uparrow \rightarrow$ CLK $\downarrow$	$t_{CHCL}$			30	100	ns	Approx. $t_{CYC}/2$ at 10 MHz oscillation

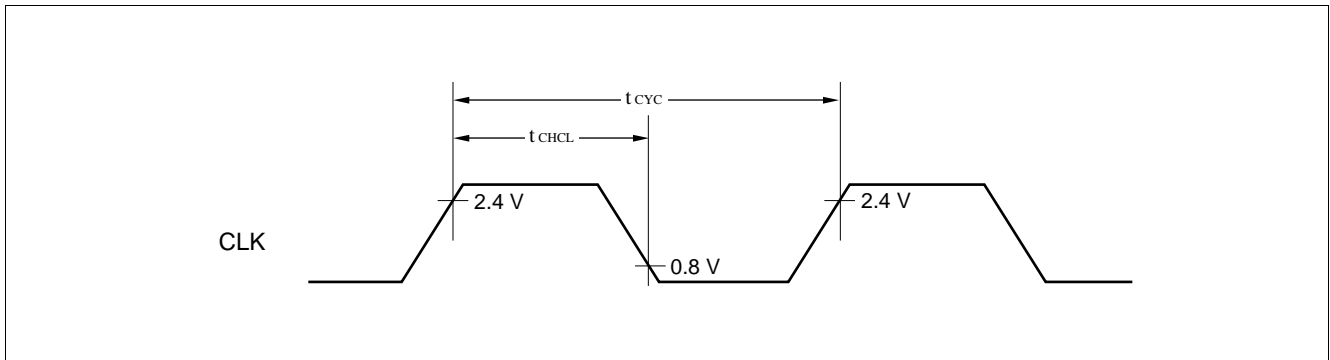

## (6) Bus Read Timing

( $V_{CC} = +5.0 V \pm 10\%$ ,  $F_C = 10 \text{ MHz}$ ,  $A_{VSS} = V_{SS} = 0.0 \text{ V}$ ,  $T_A = -40^\circ\text{C}$  to  $+85^\circ\text{C}$ )

Parameter	Symbol	Pin	Condition	Value (10 MHz)		Unit	Remarks
				Min.	Max.		
Valid address $\rightarrow \overline{\text{RD}} \downarrow$ time	$t_{AVRL}$	$\overline{\text{RD}}$ , A15 to A08, AD7 to AD0	Load condition: 50 pF	$1/4 t_{inst}^* - 64 \text{ ns}$	—	ns	
$\overline{\text{RD}}$ pulse width	$t_{RLRH}$	$\overline{\text{RD}}$		$1/2 t_{inst}^* - 20 \text{ ns}$	—	ns	
Valid address $\rightarrow$ data read time	$t_{AVDV}$	AD7 to AD0, A15 to A08		—	$1/2 t_{inst}^*$	ns	No wait
$\overline{\text{RD}} \downarrow \rightarrow$ data read time	$t_{RLDV}$	$\overline{\text{RD}}$ , AD7 to AD0		—	$1/2 t_{inst}^* - 80 \text{ ns}$	ns	No wait
$\overline{\text{RD}} \uparrow \rightarrow$ data hold time	$t_{RHDX}$	AD7 to AD0, $\overline{\text{RD}}$		0	—	ns	
$\overline{\text{RD}} \uparrow \rightarrow$ ALE $\uparrow$ time	$t_{RHLH}$	$\overline{\text{RD}}$ , ALE		$1/4 t_{inst}^* - 40 \text{ ns}$	—	ns	
$\overline{\text{RD}} \uparrow \rightarrow$ address invalid time	$t_{RHAX}$	$\overline{\text{RD}}$ , A15 to A08		$1/4 t_{inst}^* - 40 \text{ ns}$	—	ns	
$\overline{\text{RD}} \downarrow \rightarrow$ CLK $\uparrow$ time	$t_{RLCH}$	$\overline{\text{RD}}$ , CLK		$1/4 t_{inst}^* - 60 \text{ ns}$	—	ns	
CLK $\downarrow \rightarrow \overline{\text{RD}} \uparrow$ time	$t_{CLRHL}$			0	—	ns	
$\overline{\text{RD}} \downarrow \rightarrow$ BUFC $\downarrow$ time	$t_{RLBL}$	$\overline{\text{RD}}$ , BUFC		-5	—	ns	
BUFC $\uparrow \rightarrow$ valid address time	$t_{BHAV}$	A15 to A08, AD7 to AD0, BUFC	5	—	ns		

\* : For information on  $t_{inst}$ , see "(4) Instruction Cycle".

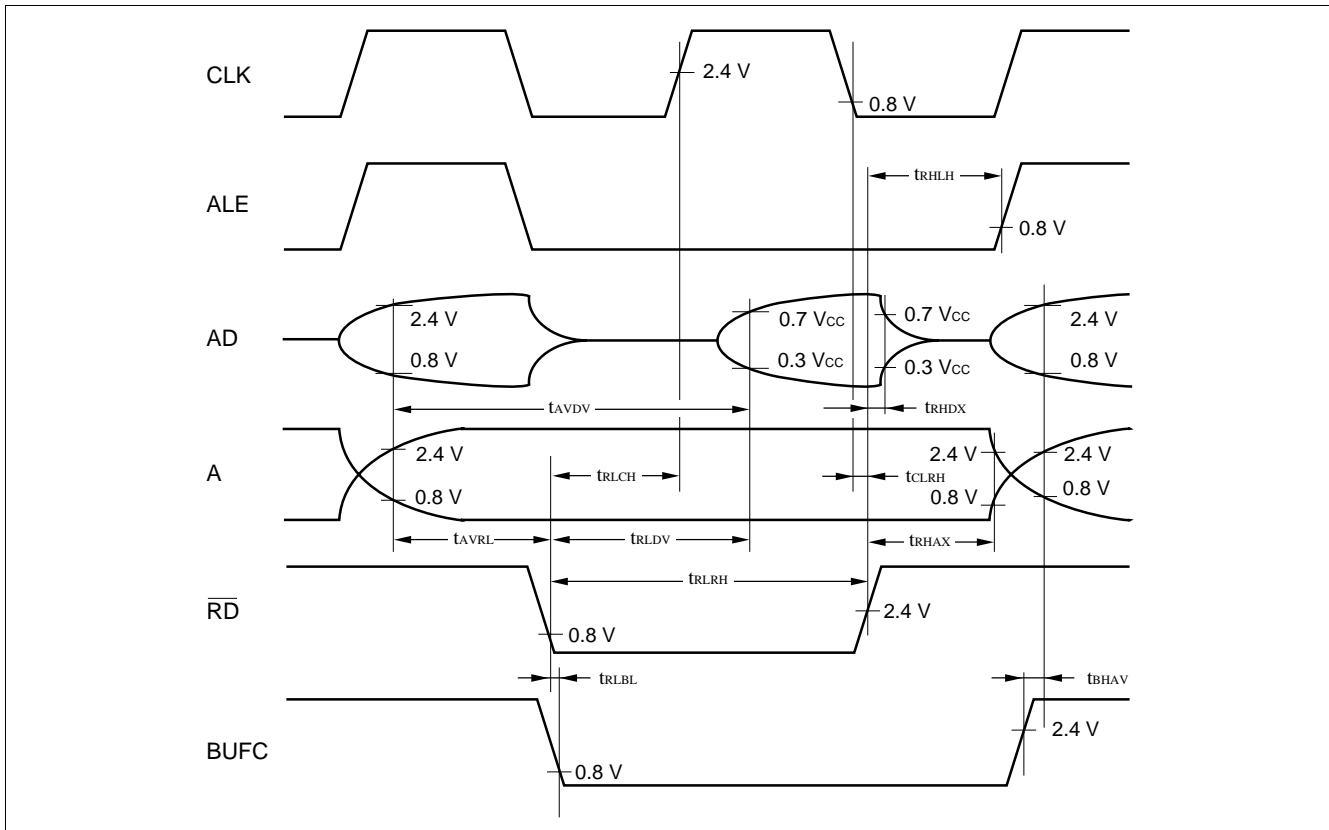

# MB89860 Series

## (7) Bus Write Timing

( $V_{CC} = +5.0 V \pm 10\%$ ,  $F_C = 10 \text{ MHz}$ ,  $A_{VSS} = V_{SS} = 0.0 \text{ V}$ ,  $T_A = -40^\circ\text{C}$  to  $+85^\circ\text{C}$ )

Parameter	Symbol	Pin	Condition	Value (10 MHz)		Unit	Remarks	
				Min.	Max.			
Valid address $\rightarrow$ ALE $\downarrow$ time	$t_{AVLL}$	AD7 to AD0, ALE, A15 to A08	Load condition: 50 pF	$1/4 t_{inst}^{*1} - 64 \text{ ns}$	—	ns		
ALE $\downarrow$ time $\rightarrow$ address invalid time	$t_{LLAX}$			5	—	ns		
Valid address $\rightarrow$ $\overline{WR}$ $\downarrow$ time	$t_{AVWL}$			$\overline{WR}$ , ALE	$1/4 t_{inst}^{*1} - 60 \text{ ns}$	—	ns	
$\overline{WR}$ pulse width	$t_{WLWH}$			$\overline{WR}$	$1/2 t_{inst}^{*1} - 20 \text{ ns}$	—	ns	
Write data $\rightarrow$ $\overline{WR}$ $\uparrow$ time	$t_{DVWH}$			AD7 to AD0, $\overline{WR}$	$1/2 t_{inst}^{*1} - 60 \text{ ns}$	—	ns	
$\overline{WR}$ $\uparrow$ $\rightarrow$ address invalid time	$t_{WHAX}$			$\overline{WR}$ , A15 to A08	$1/4 t_{inst}^{*1} - 40 \text{ ns}$	—	ns	
$\overline{WR}$ $\uparrow$ $\rightarrow$ data hold time	$t_{WHDX}$			AD7 to AD0, $\overline{WR}$	$1/4 t_{inst}^{*1} - 40 \text{ ns}$	—	ns	
$\overline{WR}$ $\uparrow$ $\rightarrow$ ALE $\uparrow$ time	$t_{WHLH}$			$\overline{WR}$ , ALE	$1/4 t_{inst}^{*1} - 40 \text{ ns}$	—	ns	
$\overline{WR}$ $\downarrow$ $\rightarrow$ CLK $\uparrow$ time	$t_{WLCH}$			$\overline{WR}$ , CLK	$1/4 t_{inst}^{*1} - 60 \text{ ns}$	—	ns	
CLK $\downarrow$ $\rightarrow$ $\overline{WR}$ $\uparrow$ time	$t_{CLWH}$				0	—	ns	
ALE pulse width	$t_{LHLL}$	ALE	$t_{XCYL} - 35 \text{ ns}^2$	—	ns			
ALE $\downarrow$ $\rightarrow$ CLK $\uparrow$ time	$t_{LLCH}$	ALE, CLK	$t_{XCYL} - 35 \text{ ns}^2$	—	ns			

\*1: For information on  $t_{inst}$ , see "(4) Instruction Cycle".

\*2: These characteristics are also applicable to the bus read timing.

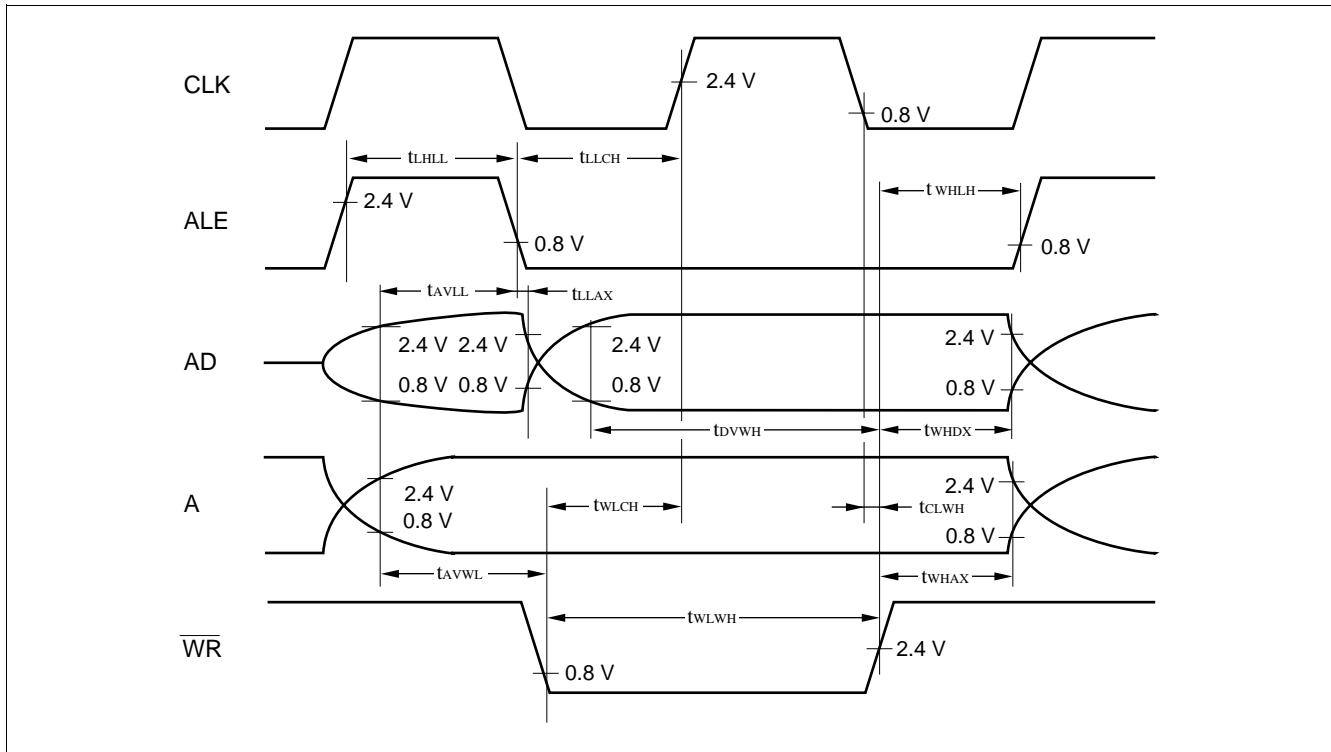

## (8) Ready Input Timing

( $V_{CC} = +5.0 V \pm 10\%$ ,  $F_c = 10 \text{ MHz}$ ,  $A_{V_{SS}} = V_{SS} = 0.0 \text{ V}$ ,  $T_A = -40^\circ\text{C}$  to  $+85^\circ\text{C}$ )

Parameter	Symbol	Pin	Condition	Value		Unit	Remarks
				Min.	Max.		
RDY valid $\rightarrow$ CLK $\uparrow$ time	$t_{YVCH}$	RDY, CLK	Load condition: 50 pF	60	—	ns	*
CLK $\uparrow$ $\rightarrow$ RDY invalid time	$t_{CHYX}$			0	—	ns	*

\* : These characteristics are also applicable to the read cycle.

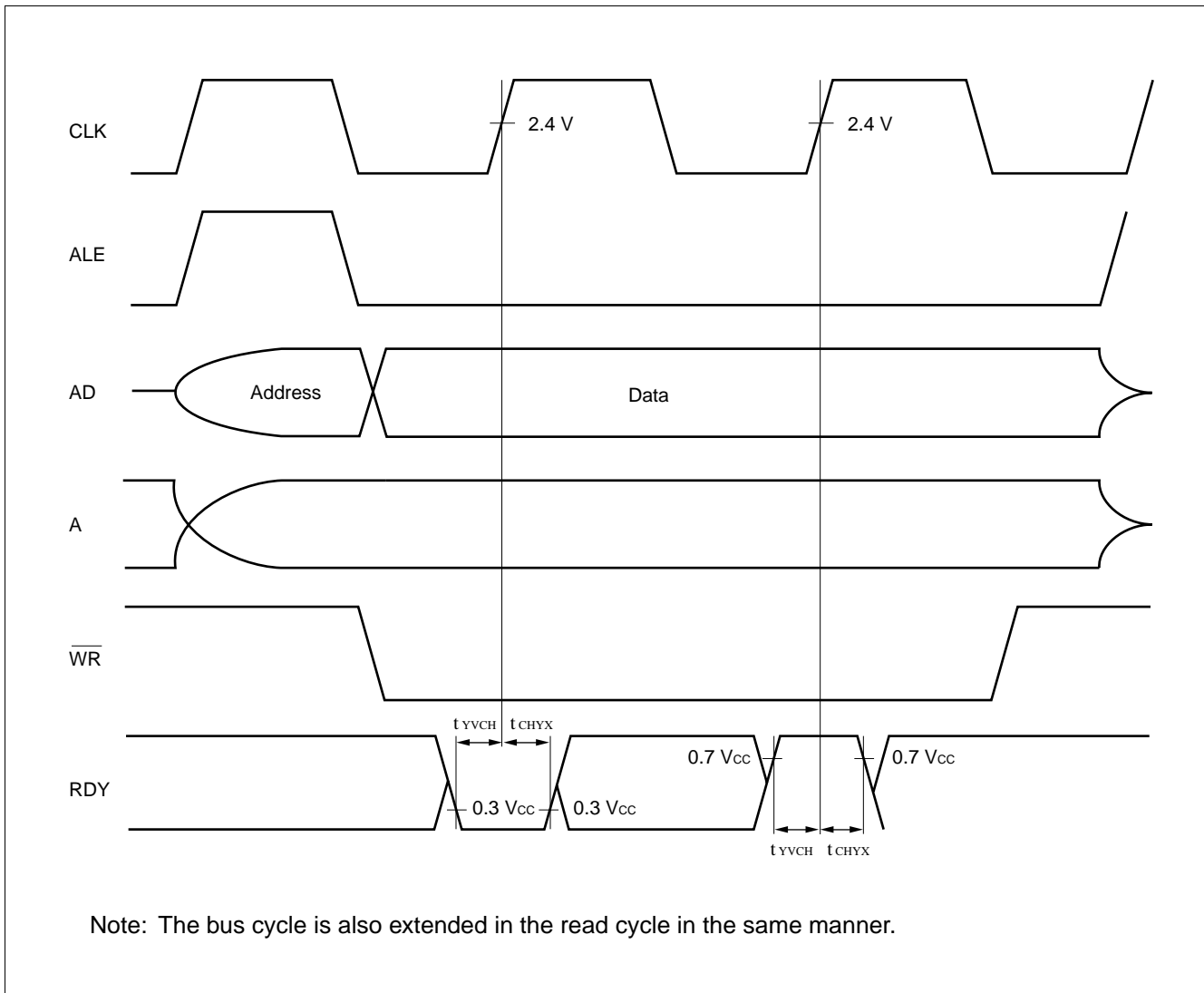

# MB89860 Series

## (9) UART and Serial I/O Timing

( $V_{CC} = +5.0 V \pm 10\%$ ,  $AV_{SS} = V_{SS} = 0.0 V$ ,  $T_A = -40^\circ C$  to  $+85^\circ C$ )

Parameter	Symbol	Pin	Condition	Value		Unit	Remarks
				Min.	Max.		
Serial clock cycle time	$t_{SCYC}$	SCK1, SCK2	Internal shift clock mode Load condition: 50 pF	$2 t_{inst}^*$	—	$\mu s$	
SCK1 $\downarrow \rightarrow$ SO1 time SCK2 $\downarrow \rightarrow$ SO2 time	$t_{SLOV}$	SCK1, SO1 SCK2, SO2		-200	200	ns	
Valid SI1 $\rightarrow$ SCK1 $\uparrow$ Valid SI2 $\rightarrow$ SCK2 $\uparrow$	$t_{IVSH}$	SI1, SCK1 SI2, SCK2		$1/2 t_{inst}^*$	—	$\mu s$	
SCK1 $\uparrow \rightarrow$ valid SI1 hold time SCK2 $\uparrow \rightarrow$ valid SI2 hold time	$t_{SHIX}$	SCK1, SI1 SCK2, SI2		$1/2 t_{inst}^*$	—	$\mu s$	
Serial clock "H" pulse width	$t_{SHSL}$	SCK1, SCK2	External shift clock mode Load condition: 50 pF	$1 t_{inst}^*$	—	$\mu s$	
Serial clock "L" pulse width	$t_{LSLH}$			$1 t_{inst}^*$	—	$\mu s$	
SCK1 $\downarrow \rightarrow$ SO1 time SCK2 $\downarrow \rightarrow$ SO2 time	$t_{SLOV}$	SCK1, SO1 SCK2, SO2		0	200	ns	
Valid SI1 $\rightarrow$ SCK1 $\uparrow$ Valid SI2 $\rightarrow$ SCK2 $\uparrow$	$t_{IVSH}$	SI1, SCK1 SI2, SCK2		$1/2 t_{inst}^*$	—	$\mu s$	
SCK1 $\uparrow \rightarrow$ valid SI1 hold time SCK2 $\uparrow \rightarrow$ valid SI2 hold time	$t_{SHIX}$	SCK1, SI1 SCK2, SI2		$1/2 t_{inst}^*$	—	$\mu s$	

\* : For information on  $t_{inst}$ , see "(4) Instruction Cycle".

## Internal Shift Clock Mode

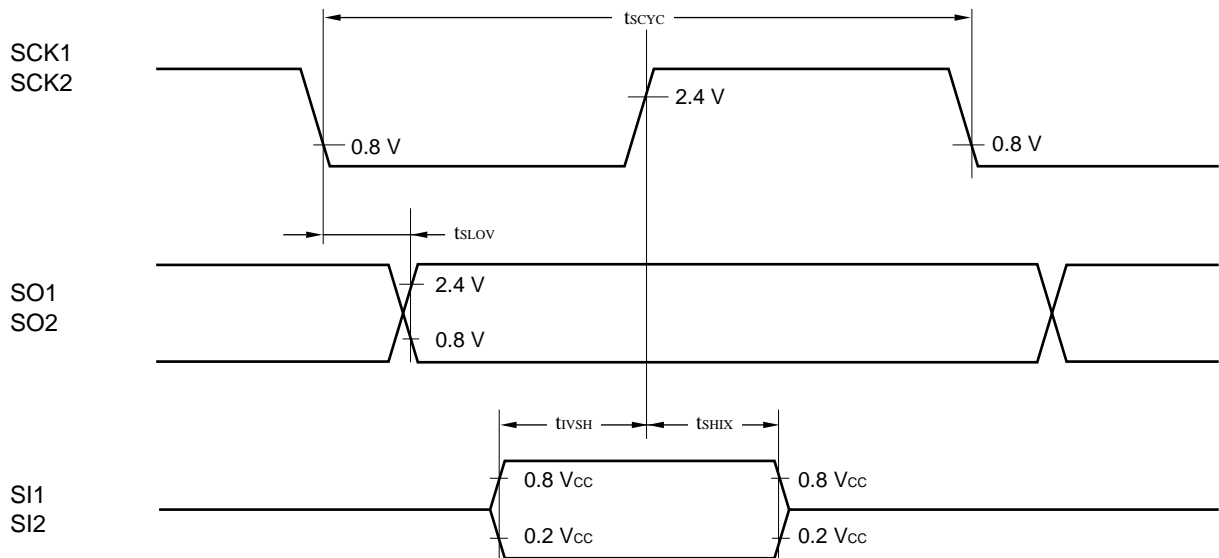

## External Shift Clock Mode

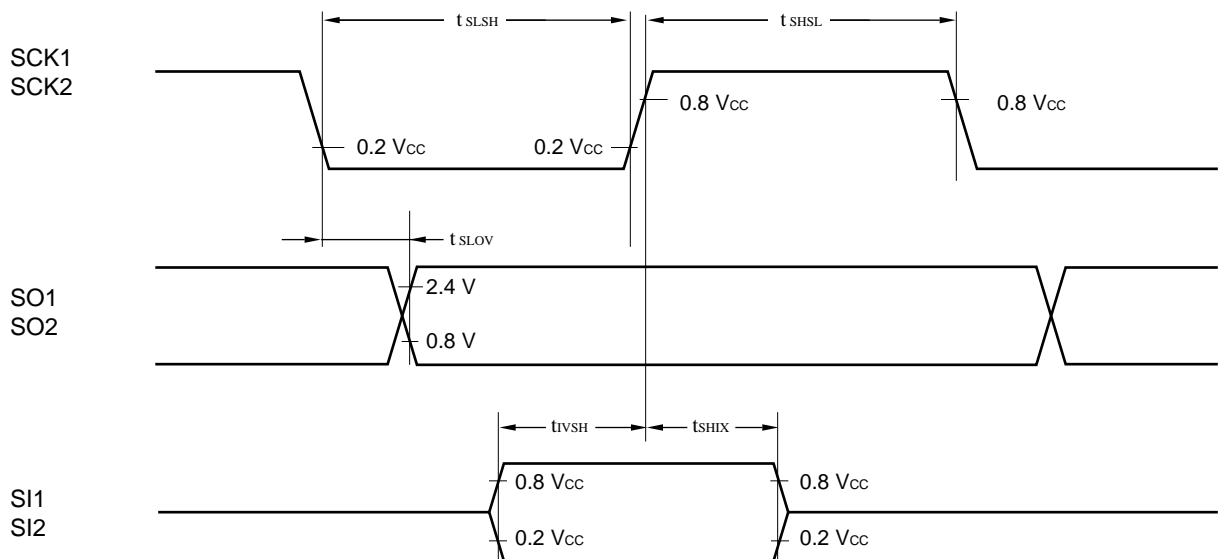

# MB89860 Series

## (10) Peripheral Input Timing

( $V_{CC} = +5.0 V \pm 10\%$ ,  $AV_{SS} = V_{SS} = 0.0 V$ ,  $T_A = -40^\circ C$  to  $+85^\circ C$ )

Parameter	Symbol	Pin	Condition	Value		Unit	Remarks
				Min.	Max.		
Peripheral input "H" pulse width 1	$t_{LH1}$	TRGI, DTTI, ADST, INT0 to INT3	Load condition: 50 pF	$2 t_{inst}^*$	—	$\mu s$	
Peripheral input "L" pulse width 1	$t_{HL1}$			$2 t_{inst}^*$	—	$\mu s$	

\* : For information on  $t_{inst}$ , see "(4) Instruction Cycle".

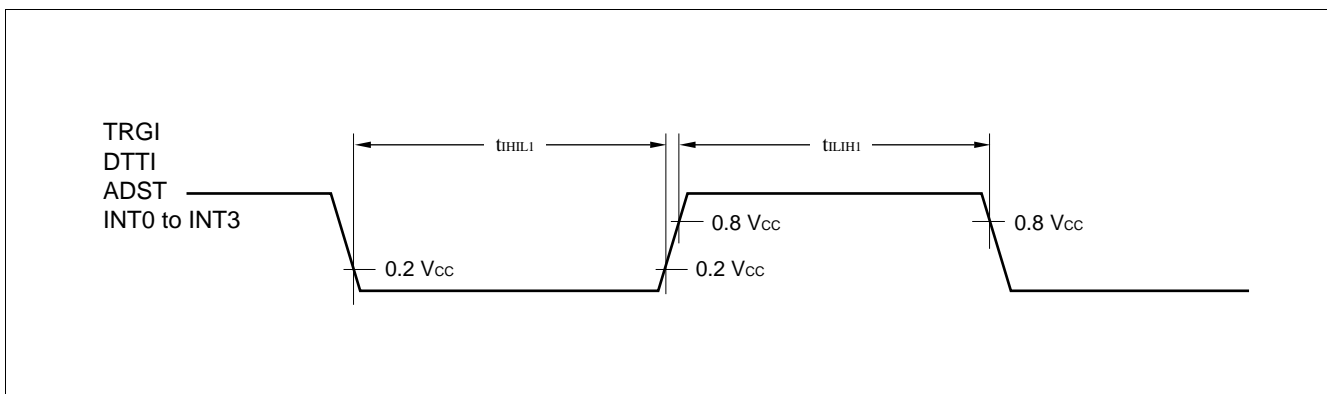

## 5. A/D Converter Electrical Characteristics

( $AV_{CC} = V_{CC} = +3.5 V$  to  $+6.0 V$ ,  $F_C = 10 MHz$ ,  $AV_{SS} = V_{SS} = 0.0 V$ ,  $T_A = -40^\circ C$  to  $+85^\circ C$ )

Parameter	Symbol	Pin	Condition	Value			Unit	Remarks
				Min.	Typ.	Max.		
Resolution	—	—	$AV_{CC} = V_{CC}$	—	—	10	bit	
Linearity error	—	—		—	—	$\pm 2.0$	LSB	
Differential linearity error	—	—		—	—	$\pm 1.5$	LSB	
Total error	—	—		—	—	$\pm 3.0$	LSB	
Zero transition voltage	$V_{OT}$	AN0 to AN7	$AV_{CC} = V_{CC}$	$AV_{SS} - 1.5 \text{ LSB}$	$AV_{SS} + 0.5 \text{ LSB}$	$AV_{SS} + 2.5 \text{ LSB}$	V	
Full-scale transition voltage	$V_{FST}$			$AVR - 3.5 \text{ LSB}$	$AVR - 1.5 \text{ LSB}$	$AVR + 0.5 \text{ LSB}$	V	
Interchannel disparity	—	—	—	—	4	LSB		
A/D mode conversion time	—	—	—	—	$33 t_{inst}^*$	$\mu s$		
Analog port input current	$I_{AIN}$	AN0 to AN7	—	—	10	$\mu A$		
Analog input voltage	—		—	0	—	AVR	V	
Reference voltage	—	AVR	—	0	$AV_{CC}$	V		
Reference voltage supply current	$I_R$		$AVR = 5.0 V$	—	200	—	$\mu A$	

\* : For information on  $t_{inst}$ , see "(4) Instruction Cycle" in "4. AC Characteristics".

## (1) A/D Glossary

- Resolution  
Analog changes that are identifiable with the A/D converter
- Linearity error  
The deviation of the straight line connecting the zero transition point (“00 0000 0000” ↔ “00 0000 0001”) with the full-scale transition point (“11 1111 1111” ↔ “11 1111 1110”) from actual conversion characteristics
- Differential linearity error  
The deviation of input voltage needed to change the output code by 1 LSB from the theoretical value
- Total error  
The total error indicates the difference between the actual value and theoretical value. This error is caused by the zero transition error, full-scale transition error, linearity error, quantization, and noise.

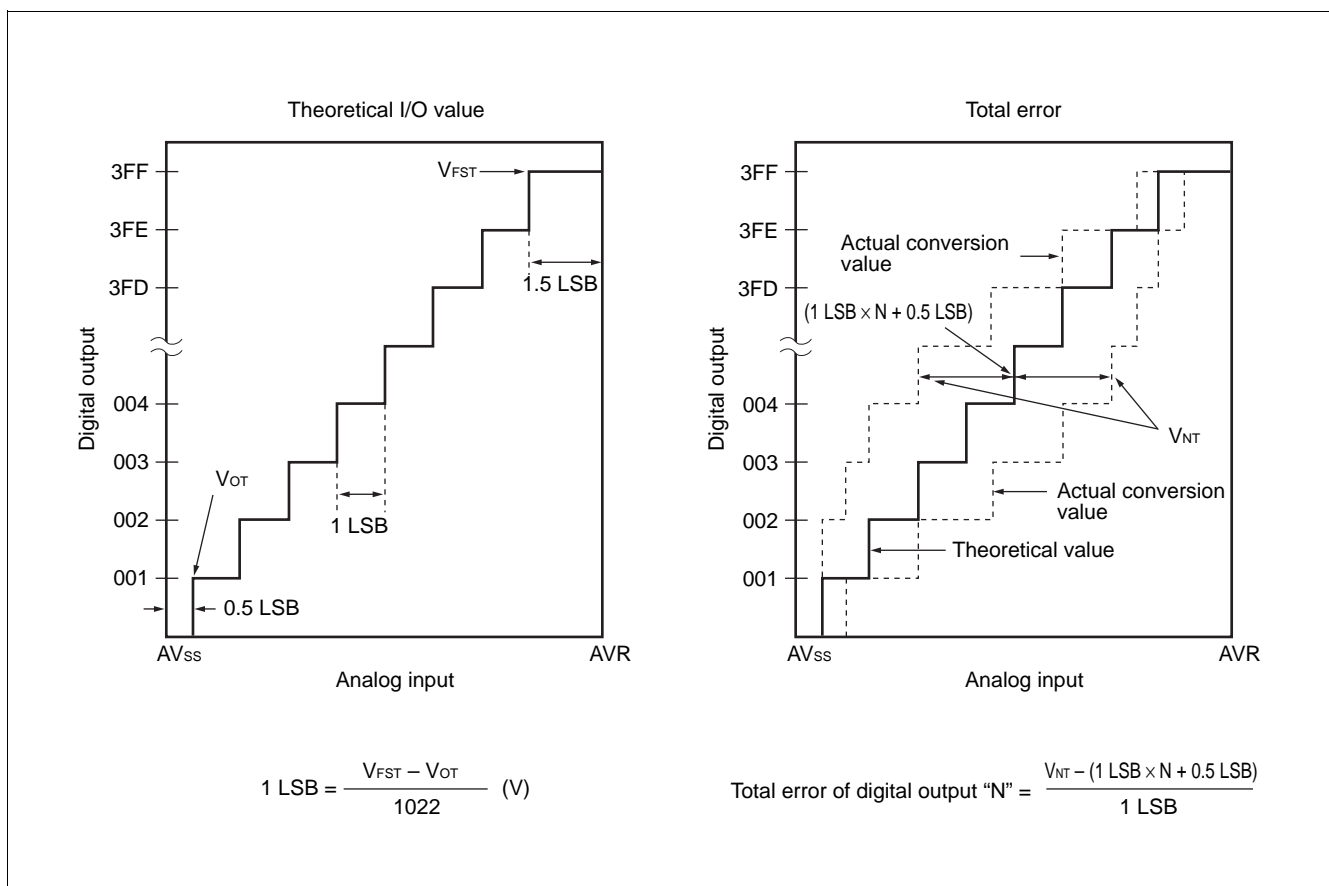

(Continued)

(Continued)

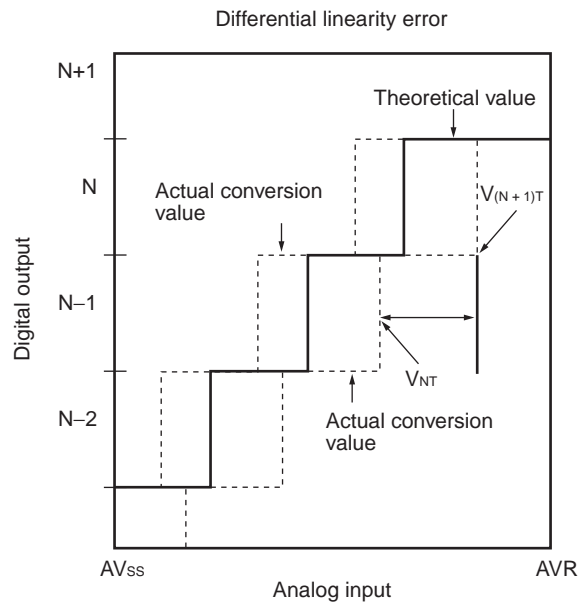
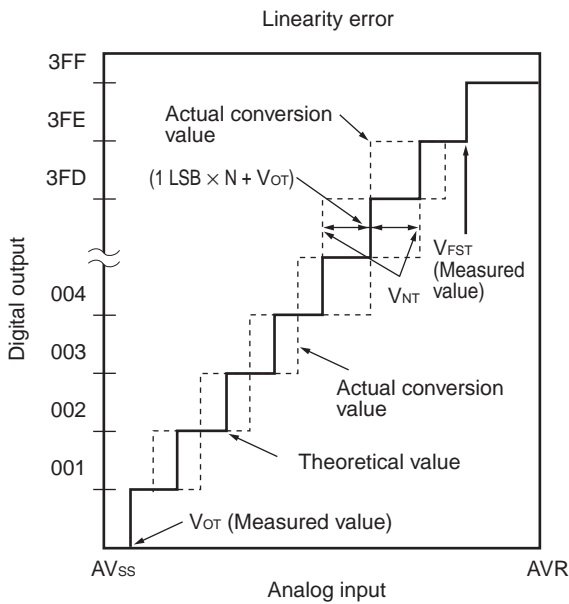
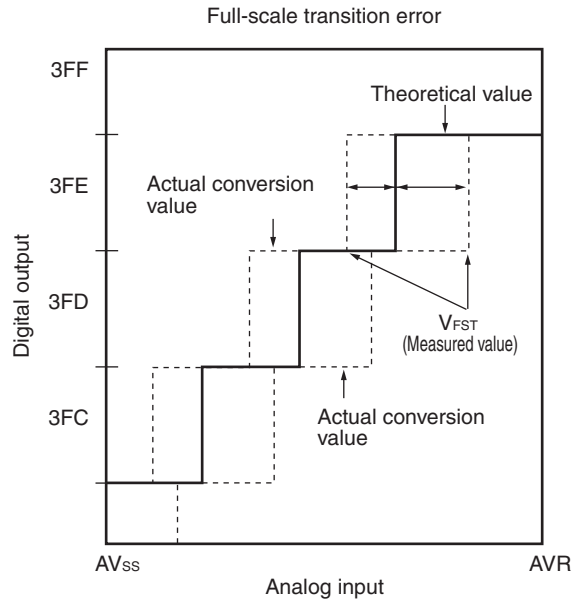
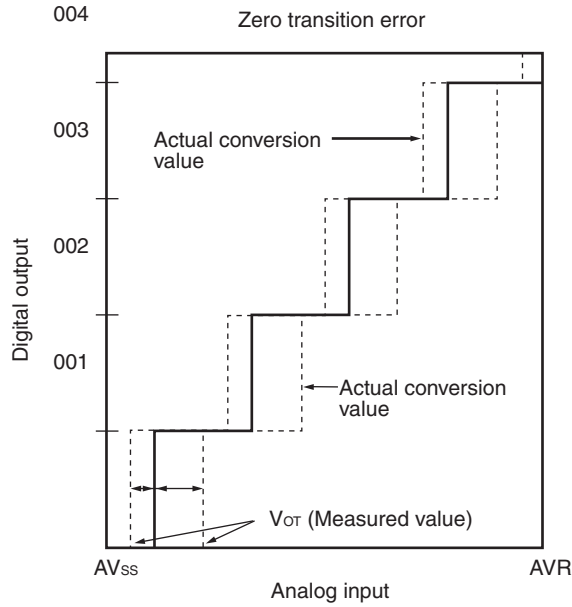

$$\text{Linearity error of digital output "N"} = \frac{V_{NT} - (1 \text{ LSB} \times N + V_{OT})}{1 \text{ LSB}}$$

$$\text{Differential linearity error of digital output "N"} = \frac{V_{(N+1)T} - V_{NT}}{1 \text{ LSB}} - 1$$

## (2) Precautions

- **Input impedance of the analog input pins**

The A/D converter used for the MB89860 series contains a sample & hold circuit as illustrated below to fetch analog input voltage into the sample & hold capacitor for fifteen instruction cycles after activation A/D conversion.

For this reason, if the output impedance of the external circuit for the analog input is high, analog input voltage might not stabilize within the analog input sampling period. Therefore, it is recommended to keep the output impedance of the external circuit low (below 10 k $\Omega$ ).

Note that if the impedance cannot be kept low, it is recommended to connect an external capacitor of about 0.1  $\mu$ F for the analog input pin.

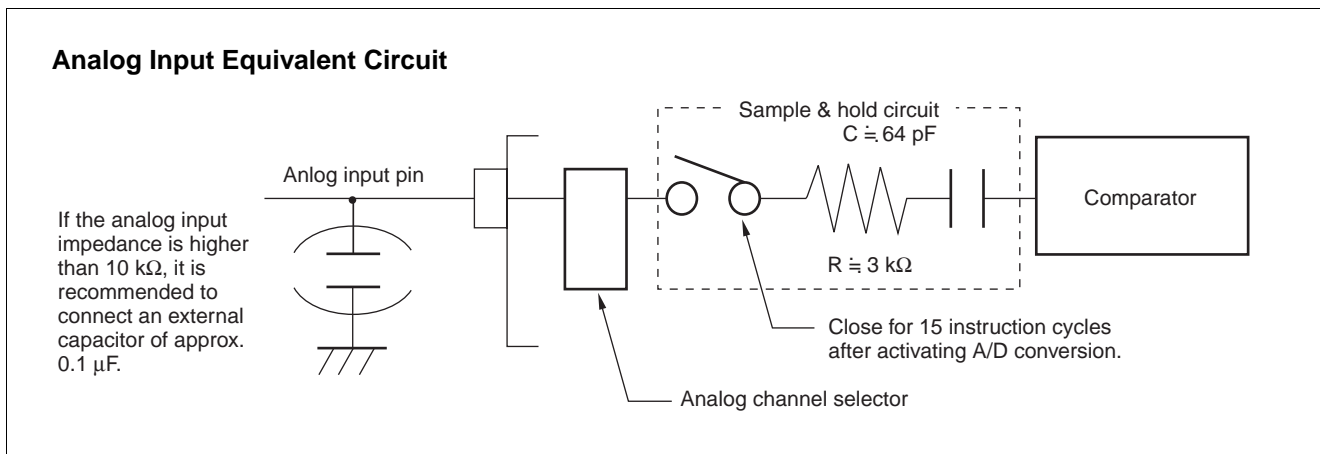

- **Error**

The smaller the  $|AVR - AV_{SS}|$ , the greater the error would become relatively.

# MB89860 Series

## EXAMPLE CHARACTERISTICS

(1) "L" Level Output Voltage (P00 to P07, P10 to P17, P20 to P27, P30 to P37, P50 to P57, P70 to P76, and P80 to P87)

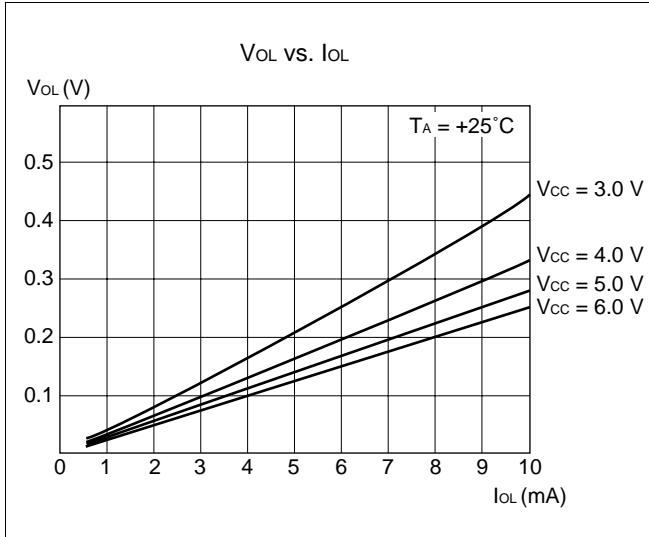

(2) "L" Level Output Voltage (P40 to P47)

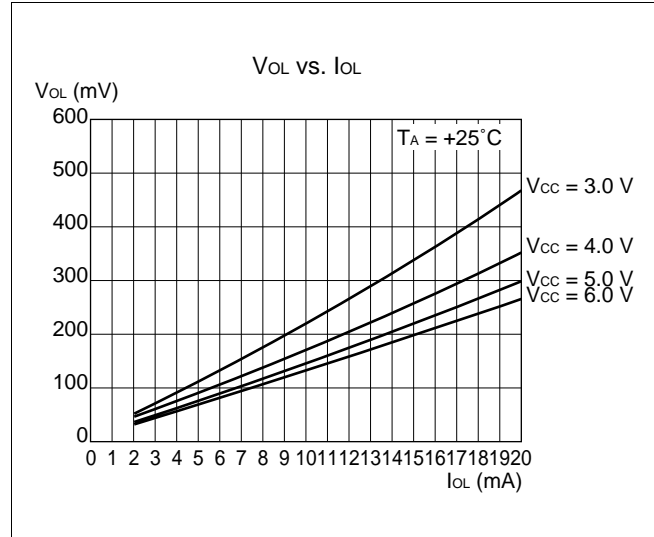

(3) "H" Level Output Voltage (P00 to P07, P10 to P17, P20 to P27, P30 to P37, and P40 to P47)

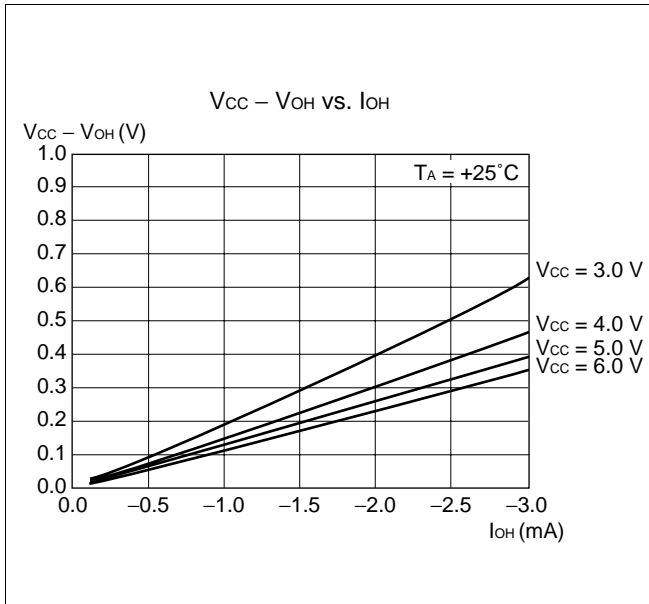

(4) Pull-up Resistance

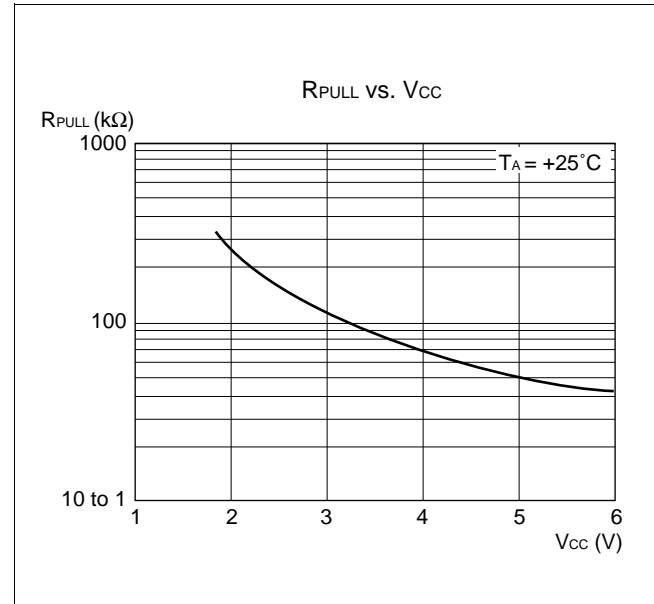

(5) "H" Level Input Voltage/"L" Level Input Voltage (CMOS Input)

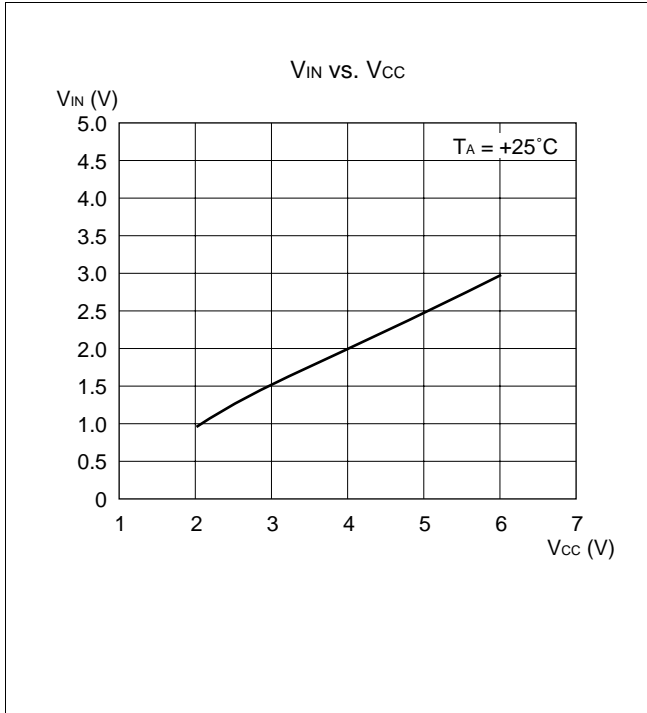

(6) "H" Level Input Voltage/"L" level Input Voltage (Hysteresis Input)

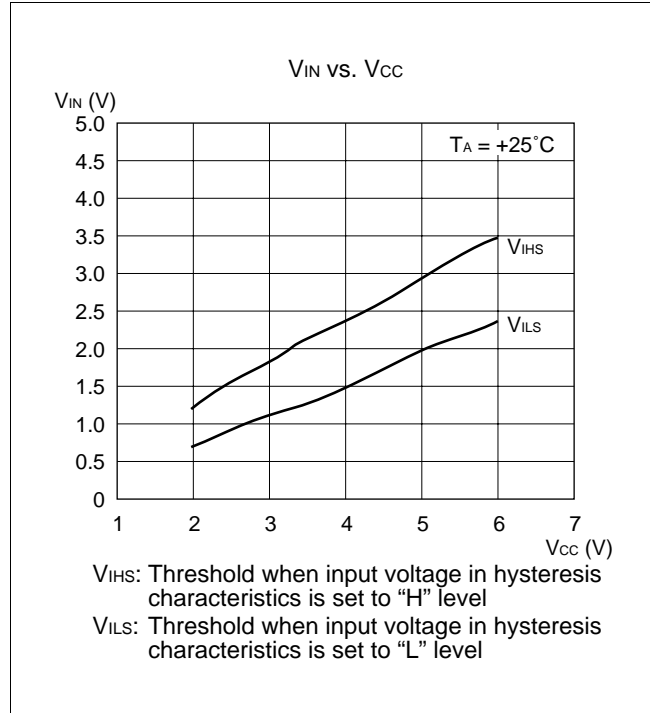

(7) Operating Supply Current vs. Frequency

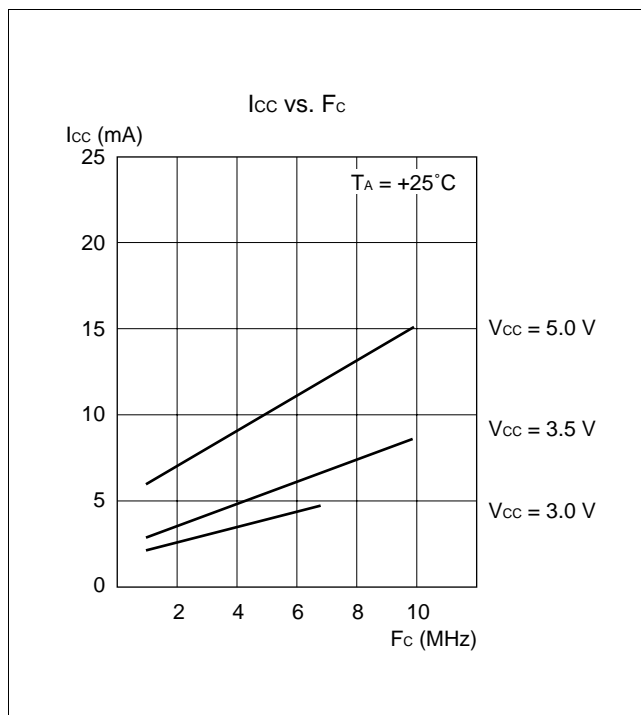

(8) Operating Supply Current vs. VCC

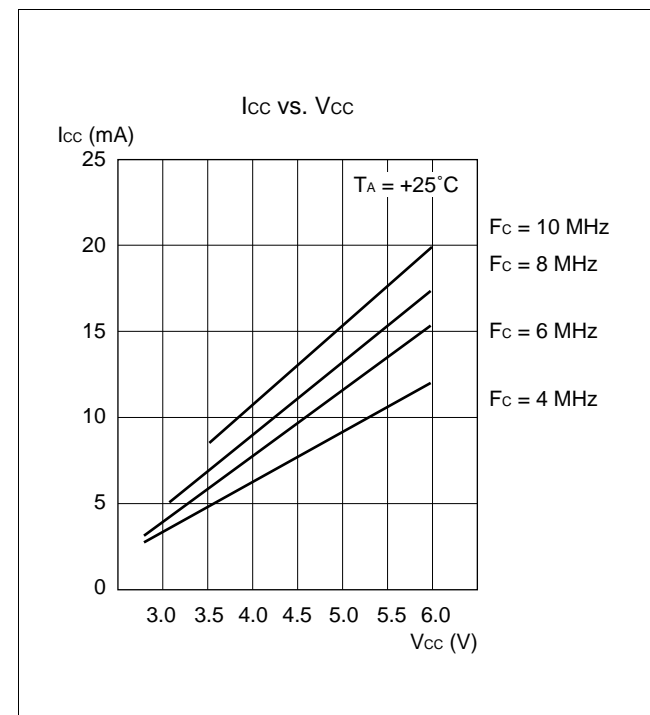

# MB89860 Series

(9) Sleep Power Supply Current vs. Frequency

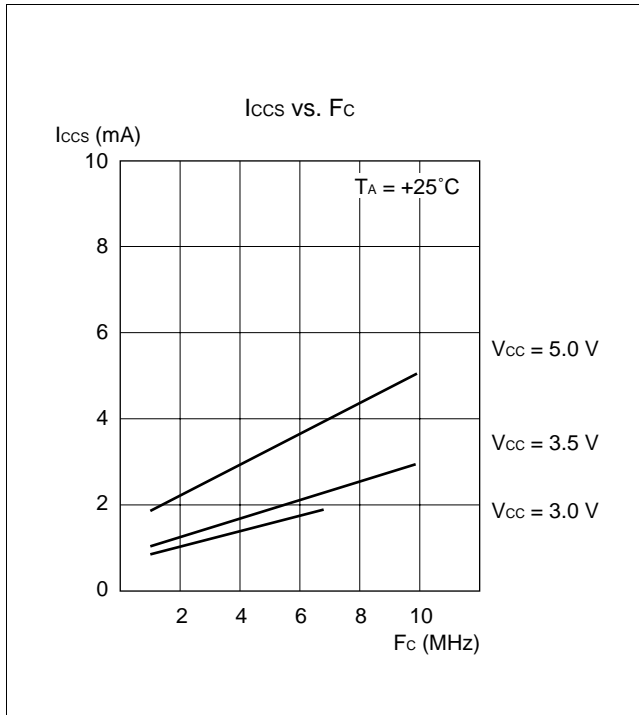

(10) Sleep Power Supply Current vs.  $V_{CC}$

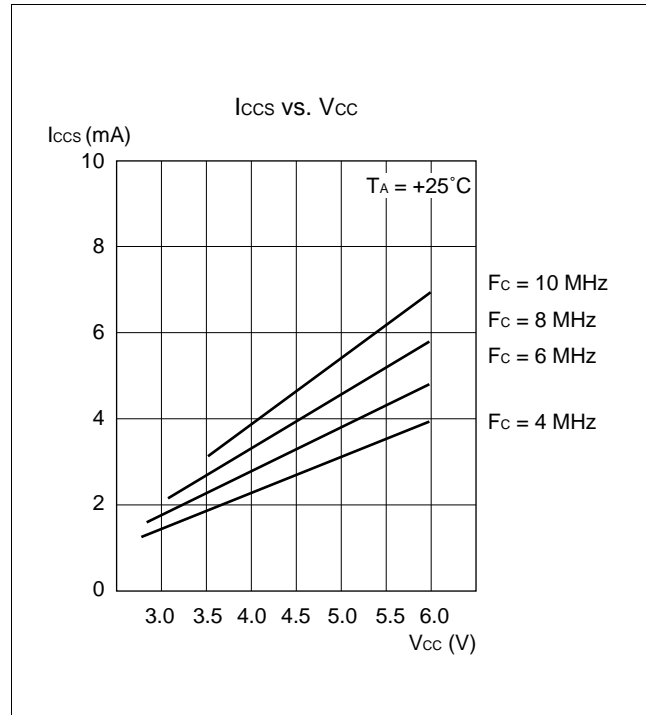

## ■ MASK OPTIONS (MB89865/867)

Option type	Option selection	Remarks
Power-on reset	0: Without power-on reset 1: With power-on reset	—
Initial value of oscillation stabilization delay time	0: $2^{18}/F_c$ (s) (Crystal oscillator) 1: $2^{14}/F_c$ (s) (Ceramic oscillator)	Selects the initial value of the OSCS bit in the STBC register during power-on reset.
Reset pin output	0: Without reset output 1: With reset output	—
Pull-up resistor at port pin P00 to P07, P10 to P17, P20 to P27, P30 to P37, P40 to P47, P60 to P64, P70 to P76, P80 to P87	1: Without pull-up resistor 0: With pull-up resistor	<ul style="list-style-type: none"> <li>• Can be set per pin.</li> <li>• P00 to P07, P10 to P17, and P20 to P27 with a pull-up resistor can be set only for single-chip mode.</li> </ul>

## ■ STANDARD OPTION LIST

Part number	MB89P867/W867
Power-on reset	Available
Initial value of oscillation stabilization delay time	$2^{18}/F_c$ (s)
Output at reset pin	Available
Pull-up resistor at port pin	Not available

## ■ ORDERING INFORMATION

Part number	Package	Remarks
MB89865PF MB89867PF MB89P867PF	80-pin Plastic QFP (FPT-80P-M06)	
MB89W867CF	80-pin Ceramic QFP (FPT-80C-A02)	ES level only

# MB89860 Series

## PACKAGE DIMENSIONS

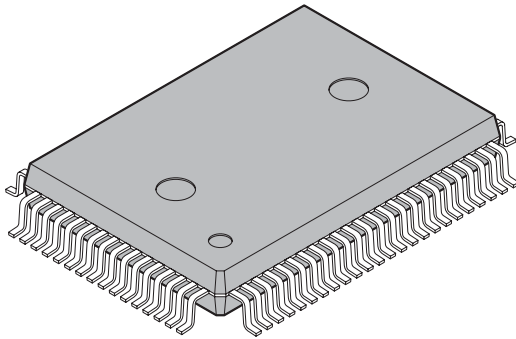
 <p>80-pin plastic QFP</p> <p>(FPT-80P-M06)</p>	Lead pitch	0.80 mm
	Package width × package length	14.00 × 20.00 mm
	Lead shape	Gullwing
	Sealing method	Plastic mold
	Mounting height	3.35 mm MAX
	Code (Reference)	P-QFP80-14×20-0.80

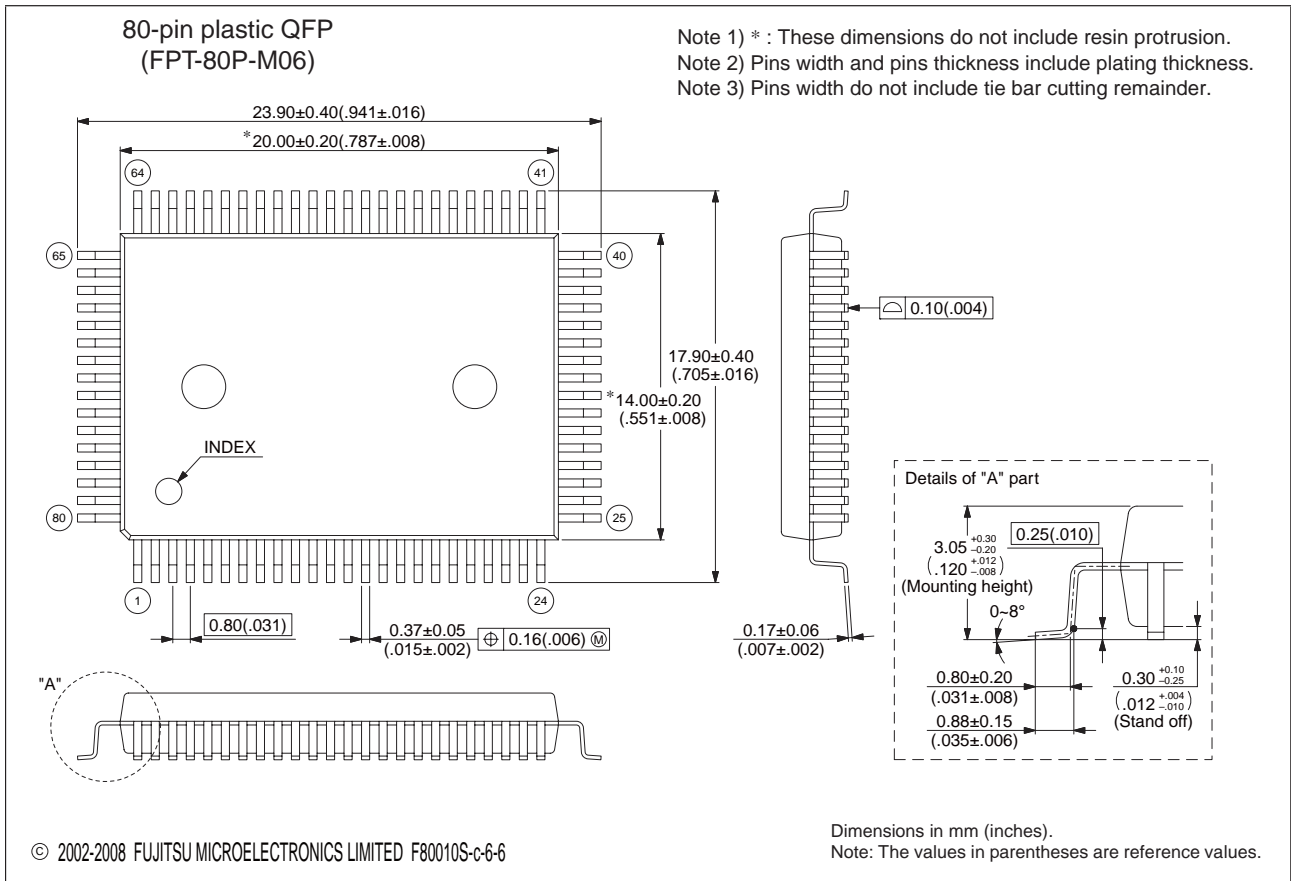

Please confirm the latest Package dimension by following URL.  
<http://edevice.fujitsu.com/package/en-search/>

(Continued)

# MB89860 Series

(Continued)

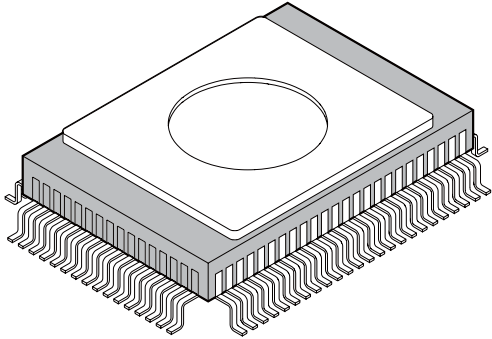
<p style="text-align: center;">80-pin ceramic QFP</p>  <p style="text-align: center;">(FPT-80C-A02)</p>	Lead pitch	0.8 mm
	Lead shape	Gullwing
	Sealing method	Metal seal

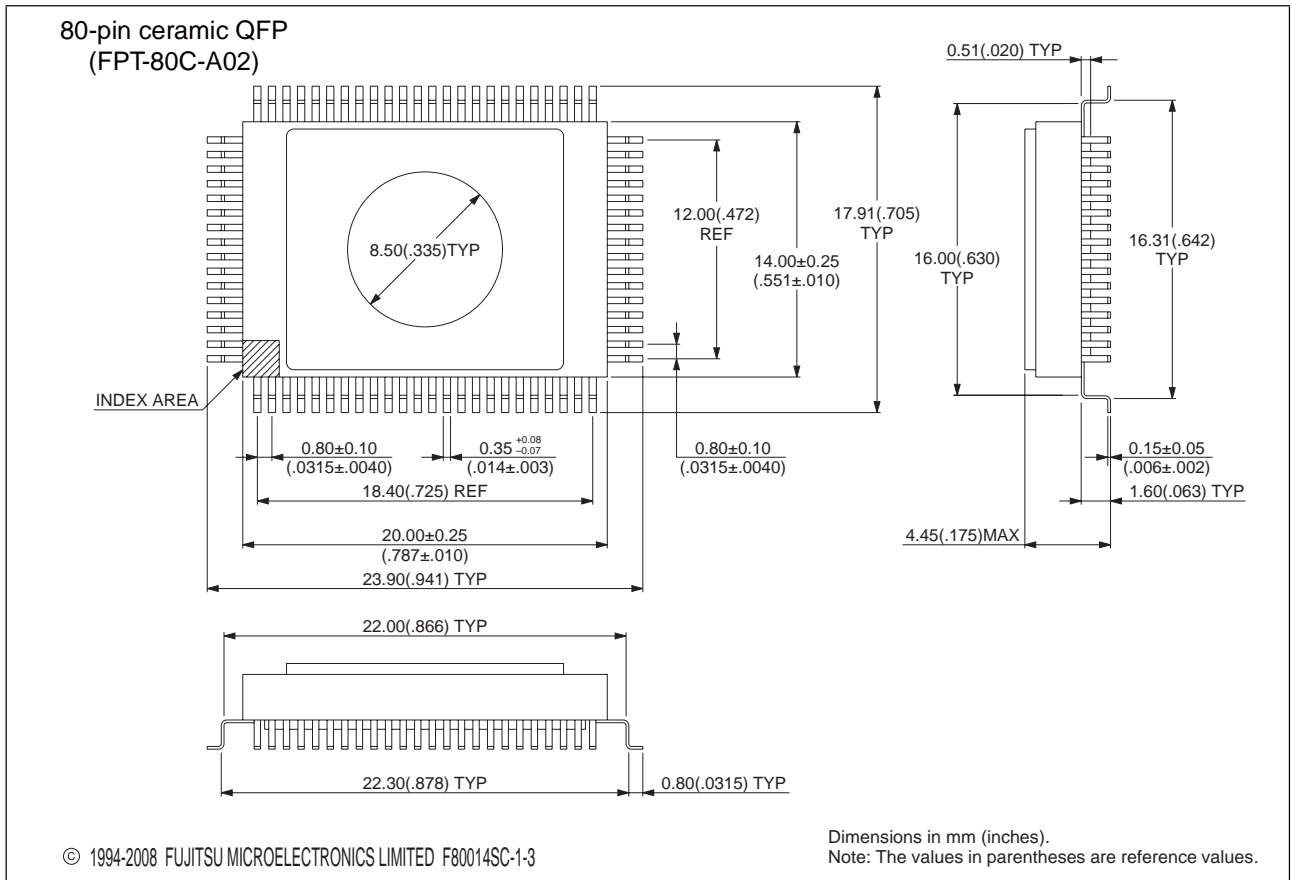

Please confirm the latest Package dimension by following URL.  
<http://edevice.fujitsu.com/package/en-search/>

# MB89860 Series

## ■ MAIN CHANGES IN THIS EDITION

Page	Section	Change Results
—	—	Changed the series name; MB89860/850 series → MB89860 series
—	—	Deleted the part numbers. MB89855, MB89857, MB89P857, MB89W857, MB89T855
—	—	Deleted the package code. DIP-64P-M01, DIP-64C-A06
13	■ PROGRAMMING TO THE EPROM ON THE MB89P867/W867	Deleted the “7. EPROM Programmer Socket Adapter”.
25	■ ELECTRICAL CHARACTERISTICS 4. AC Characteristics	Deleted the “(5) Recommended Resonator Manufacturers”.
32	■ ELECTRICAL CHARACTERISTICS 5. A/D Converter Electrical Characteristics	Changed the items of "Zero transition voltage" and "Full-scale transition voltage". Unit : LSB → V AV <sub>SS</sub> /AVR ± value → AV <sub>SS</sub> /AVR ± value LSB
38	■ INSTRUCTIONS	Deleted the “INSTRUCTIONS”.
	■ INSTRUCTION MAP	Deleted the “INSTRUCTION MAP”.

The vertical lines marked in the left side of the page show the changes.

**MEMO**

# MB89860 Series

## FUJITSU MICROELECTRONICS LIMITED

Shinjuku Dai-Ichi Seimei Bldg., 7-1, Nishishinjuku 2-chome,  
Shinjuku-ku, Tokyo 163-0722, Japan  
Tel: +81-3-5322-3347 Fax: +81-3-5322-3387  
<http://jp.fujitsu.com/fml/en/>

*For further information please contact:*

### North and South America

FUJITSU MICROELECTRONICS AMERICA, INC.  
1250 E. Arques Avenue, M/S 333  
Sunnyvale, CA 94085-5401, U.S.A.  
Tel: +1-408-737-5600 Fax: +1-408-737-5999  
<http://www.fma.fujitsu.com/>

### Asia Pacific

FUJITSU MICROELECTRONICS ASIA PTE. LTD.  
151 Lorong Chuan,  
#05-08 New Tech Park 556741 Singapore  
Tel : +65-6281-0770 Fax : +65-6281-0220  
<http://www.fmal.fujitsu.com/>

### Europe

FUJITSU MICROELECTRONICS EUROPE GmbH  
Pittlerstrasse 47, 63225 Langen, Germany  
Tel: +49-6103-690-0 Fax: +49-6103-690-122  
<http://emea.fujitsu.com/microelectronics/>

### FUJITSU MICROELECTRONICS SHANGHAI CO., LTD.

Rm. 3102, Bund Center, No.222 Yan An Road (E),  
Shanghai 200002, China  
Tel : +86-21-6146-3688 Fax : +86-21-6335-1605  
<http://cn.fujitsu.com/fmc/>

### Korea

FUJITSU MICROELECTRONICS KOREA LTD.  
206 Kosmo Tower Building, 1002 Daechi-Dong,  
Gangnam-Gu, Seoul 135-280, Republic of Korea  
Tel: +82-2-3484-7100 Fax: +82-2-3484-7111  
<http://kr.fujitsu.com/fmk/>

### FUJITSU MICROELECTRONICS PACIFIC ASIA LTD.

10/F., World Commerce Centre, 11 Canton Road,  
Tsimshatsui, Kowloon, Hong Kong  
Tel : +852-2377-0226 Fax : +852-2376-3269  
<http://cn.fujitsu.com/fmc/en/>

Specifications are subject to change without notice. For further information please contact each office.

### All Rights Reserved.

The contents of this document are subject to change without notice.

Customers are advised to consult with sales representatives before ordering.

The information, such as descriptions of function and application circuit examples, in this document are presented solely for the purpose of reference to show examples of operations and uses of FUJITSU MICROELECTRONICS device; FUJITSU MICROELECTRONICS does not warrant proper operation of the device with respect to use based on such information. When you develop equipment incorporating the device based on such information, you must assume any responsibility arising out of such use of the information.

FUJITSU MICROELECTRONICS assumes no liability for any damages whatsoever arising out of the use of the information.

Any information in this document, including descriptions of function and schematic diagrams, shall not be construed as license of the use or exercise of any intellectual property right, such as patent right or copyright, or any other right of FUJITSU MICROELECTRONICS or any third party or does FUJITSU MICROELECTRONICS warrant non-infringement of any third-party's intellectual property right or other right by using such information. FUJITSU MICROELECTRONICS assumes no liability for any infringement of the intellectual property rights or other rights of third parties which would result from the use of information contained herein.

The products described in this document are designed, developed and manufactured as contemplated for general use, including without limitation, ordinary industrial use, general office use, personal use, and household use, but are not designed, developed and manufactured as contemplated (1) for use accompanying fatal risks or dangers that, unless extremely high safety is secured, could have a serious effect to the public, and could lead directly to death, personal injury, severe physical damage or other loss (i.e., nuclear reaction control in nuclear facility, aircraft flight control, air traffic control, mass transport control, medical life support system, missile launch control in weapon system), or (2) for use requiring extremely high reliability (i.e., submersible repeater and artificial satellite).

Please note that FUJITSU MICROELECTRONICS will not be liable against you and/or any third party for any claims or damages arising in connection with above-mentioned uses of the products.

Any semiconductor devices have an inherent chance of failure. You must protect against injury, damage or loss from such failures by incorporating safety design measures into your facility and equipment such as redundancy, fire protection, and prevention of over-current levels and other abnormal operating conditions.

Exportation/release of any products described in this document may require necessary procedures in accordance with the regulations of the Foreign Exchange and Foreign Trade Control Law of Japan and/or US export control laws.

The company names and brand names herein are the trademarks or registered trademarks of their respective owners.

Edited: Business & Media Promotion Dept.