

ASSP For Screen Display Control

CMOS

On-Screen Display Controller

MB90099

■ DESCRIPTION

The MB90099 is an on-screen display controller for displaying text and graphics on the TV screen. The three-channel output control function, compact package and low voltage operation make this device suitable for on-screen displays in portable devices including camera-integrated VTRs and digital still cameras.

The MB90099 controls a display area of 28 characters by 12 lines, and provides 1,024 different characters, each composed of 12×18 dots. All 1,024 characters in font ROM can be set by the user. The display functions include a wealth of characters with qualifying functions such as character background shading (shadow casting) and individual character size setting, with 16-color display selection for each character. Also included are the line background, screen background, and sprite character functions, providing a wide variety of screen display capabilities.

■ FEATURES

- Character screen configuration : 28 characters \times 12 lines (maximum)
- Character types : 1,024 characters (integrated in ROM, user definable through the entire area)

(Continued)

■ PACKAGE

20-pin plastic SSOP

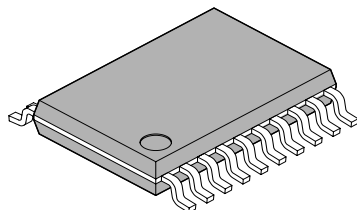

(FPT-20P-M03)

20-pin plastic FLGA

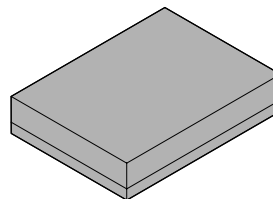

(LGA-20P-M01)

(Continued)

- Font configuration : 12 × 18 dots (font ROM configuration)
Horizontal/vertical character display size setting enabled.
Two horizontal width settings (S/L) per character.
S size : 6 dots
L size : 12 dots
Two vertical height settings (HA/HB) per line.
HA : 18 dots
HB : 12 dots
- Display modes : Character trimming : Enabled/Disabled (set for each line)
Character background :
None/Solid-fill/Shaded background (concave) /Shaded background (convex)
(set for each character)
Horizontal character merge/independent display with shaded background (set for each character)
Vertical line merge/independent display with shaded background (set for each line)
Character background display extended to line spacings : Enabled/Disabled (set for each line)
Line background :
None/Solid-fill/Shaded background (concave) /Shaded background (convex)
(set for each line)
(Display extends into left and right screen margins and into line spacings)
Character enlargement :
4 types : Normal, Double width, Double height, Double width × double height (set for each line)
Enlarged character dot interpolation function (set for each line)
- Character screen display position control : Horizontal display position :
Control in 2-dot units (movable through the entire screen)
Vertical display position :
Control in 2-dot units (movable through the entire screen)
Line spacing control :
Control in 1-dot units (set between 0 to 7 dots for each line, applied simultaneously to two areas above and below the line)
- Sprite character control : Sprite character display : Enable/Disabled
Sprite character types : 256 types (character codes 000_H to 0FF_H)
Sprite character trimming : Enabled/Disabled
Sprite character configuration : 2 types : 1 character/Stack of 2 characters
Sprite character horizontal display position : Control in 1-dot units (movable through the entire screen)
Sprite character vertical display position : Control in 1-dot units (movable through the entire screen)
- Screen background control : Screen background color : Enabled/Disabled

- Display colors :
 - Character color : 16 colors (set for each character)
 - Character trimming color : 16 colors (set for each line)
 - Character background color : 16 colors (set for each character) *
 - Line background color : 16 colors (set for each line)
 - Screen background color : 16 colors
 - Sprite character color : 16 colors
 - Sprite character trimming color : 16 colors
 - Shaded background frame highlight color : 16 colors
 - Shaded background frame shadow color : 16 colors
- Display signal output :
 - Color signal output : 4 bits (supports 16 colors)
 - Display period signals : 3 channels (output selector circuit provided)
- External interface :
 - 16-bit serial input :
 - Chip select
 - Serial clock
 - Serial data
- Package :
 - SSOP-20
 - FLGA-20
- Supply voltage : 2.4 V to 3.6 V

* : Character background color (color code) = "0" is transparent (displays lower-layer color) .

■ PIN ASSIGNMENTS

(TOP VIEW)

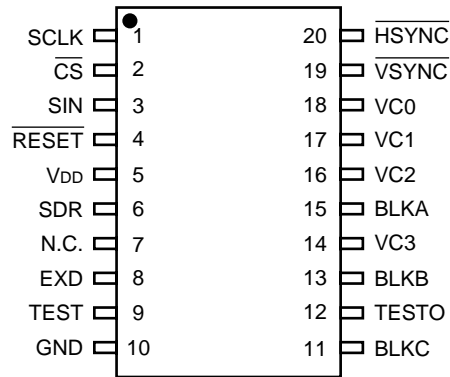

SSOP-20
(FPT-20P-M03)

(TOP VIEW)

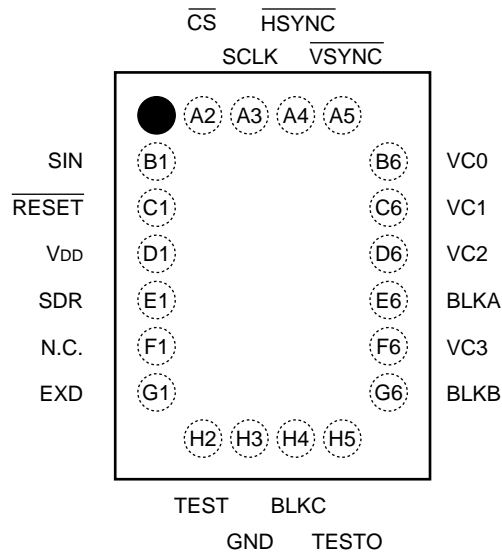

FLGA-20
(LGA-20P-M01)

■ PIN DESCRIPTIONS

Pin no.		Pin name	I/O	Circuit type	Function
SSOP	FLGA				
1	A3	SCLK	I	A	Shift clock input pin for serial transfer. This pin has an internal pull-up resistor.
2	A2	\overline{CS}	I	A	Chip select pin. Input a low level signal during serial transfer. This pin has an internal pull-up resistor.
3	B1	SIN	I	A	Serial data input pin. This pin has an internal pull-up resistor.
4	C1	\overline{RESET}	I	B	Reset input pin. Input a low level signal at power-on time.
5	D1	V _{DD}	—	—	+3 V power supply pin.
6	E1	SDR	I	C	Data input direction select pin for serial transfer. Input a low level signal at LSB-first transfer mode, or a high level signal at MSB-first transfer mode.
7	F1	N.C.	—	—	Not connected. This pin should be left open.
8	G1	EXD	I	B	Display dot clock input pin.
9	H2	TEST	I	C	LSI test input pin. Input a low level signal during normal use.
10	H3	GND	—	—	Ground pin.
11	H4	BLKC	O	D	Display period signal output pin for output channel C.
12	H5	TESTO	O	D	LSI test output pin. This pin should be left open during normal use.
13	G6	BLKB	O	D	Display period signal output pin for output channel B.
15	E6	BLKA	O	D	Display period signal output pin for output channel A.
14	F6	VC3	O	D	Color code signal output pins.
16	D6	VC2	O		
17	C6	VC1	O		
18	B6	VC0	O		
19	A5	\overline{VSYNC}	I	B	Vertical synchronization signal input pin.
20	A4	\overline{HSYNC}	I	B	Horizontal synchronization signal input pin.

■ I/O CIRCUIT TYPES

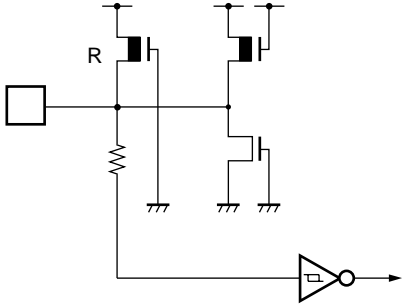
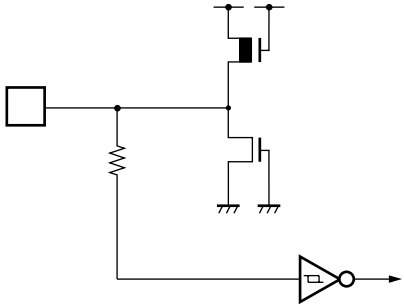
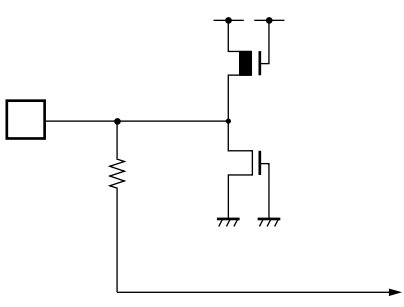
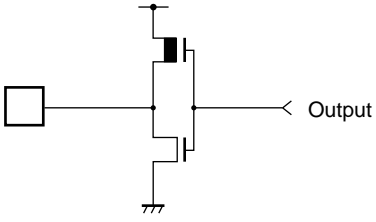
Type	Circuit	Remarks
A		CMOS level, hysteresis input, pull-up resistance (25 kΩ to 200 kΩ) .
B		CMOS level, hysteresis input.
C		CMOS level input.
D		CMOS level output.

■ BLOCK DIAGRAM

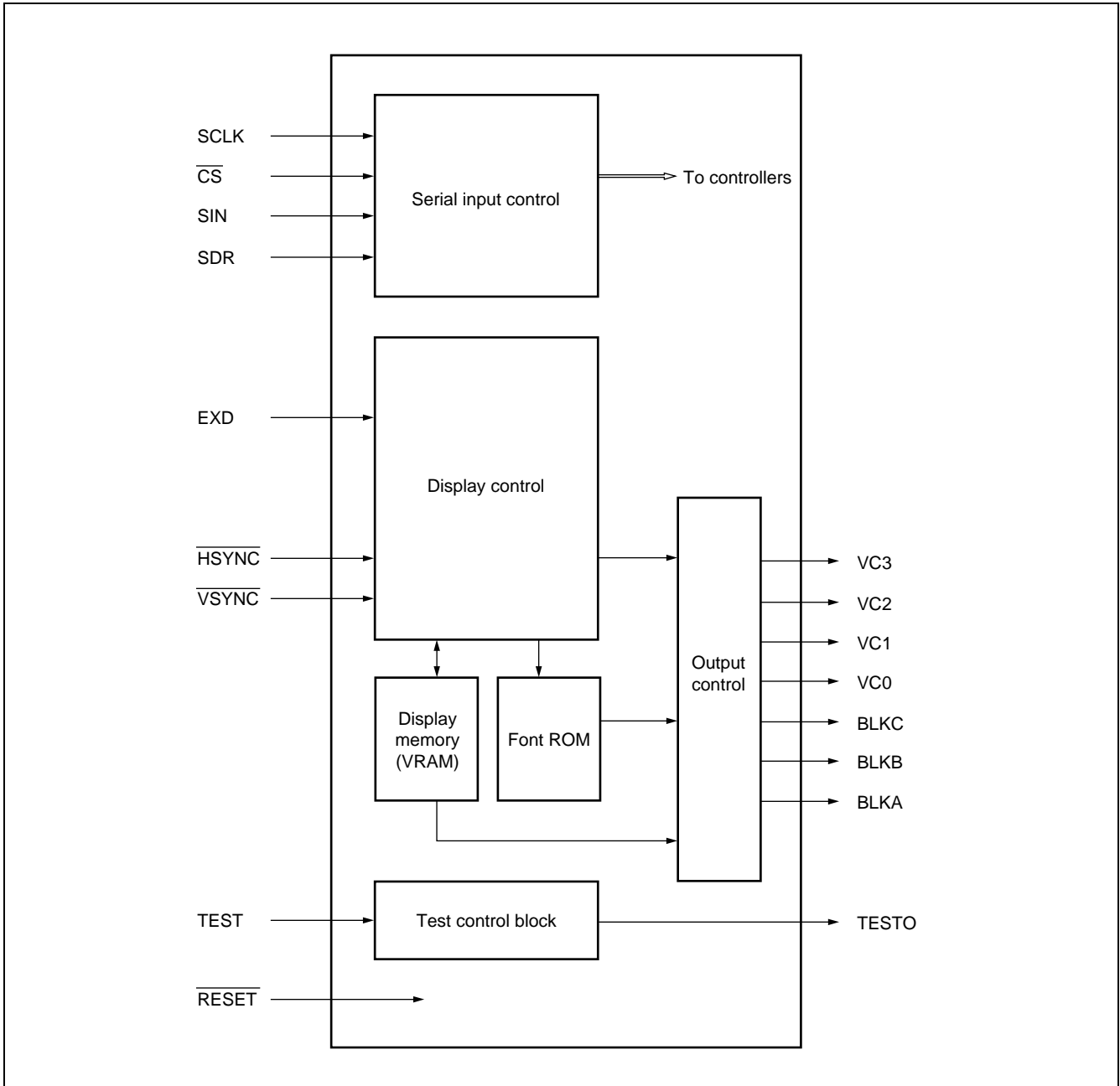

■ COMPONENT ELEMENTS

- Serial input control block
Receives serial commands and data. Decodes commands, and allocates commands and data to the appropriate control blocks.
- Display control block
Performs display control functions synchronized with the input sync signals.
- Display memory (VRAM) block
VRAM memory for character data (24 bits × 28 characters × 12 lines) and line data (24 bits × 12 lines) .
- Font ROM block
ROM memory for display character fonts. Configured for 1,024 characters of 12 dots × 18 dots.
- Output control block
Generates output signals by applying display processing to the font data read from the font ROM.
- Test control block
Circuits for factory testing of the LSI before delivery.

■ ABSOLUTE MAXIMUM RATINGS

($V_{GND} = 0\text{ V}$)

Parameter	Symbol	Rating		Unit	Remarks
		Min.	Max.		
Power supply voltage	V_{DD}	$V_{GND} - 0.5$	$V_{GND} + 4.0$	V	
Input voltage	V_{IN}	$V_{GND} - 0.5$	$V_{DD} + 0.5$	V	
Output voltage	V_{OUT}	$V_{GND} - 0.5$	$V_{DD} + 0.5$	V	
Power consumption	P_d	—	100	mW	
Operating temperature	T_a	-20	+70	°C	
Storage temperature	T_{stg}	-55	+150	°C	

WARNING: Semiconductor devices can be permanently damaged by application of stress (voltage, current, temperature, etc.) in excess of absolute maximum ratings. Do not exceed these ratings.

■ RECOMMENDED OPERATING CONDITIONS

($V_{GND} = 0\text{ V}$)

Parameter	Symbol	Value		Unit	Remarks
		Min.	Max.		
Power supply voltage	V_{DD}	2.4	3.6	V	
“H” level input voltage 1	V_{IHS}	$0.8 \times V_{DD}$	$V_{DD} + 0.3$	V	*1
“L” level input voltage 1	V_{ILS}	V_{GND}	$0.2 \times V_{DD}$	V	*1
“H” level input voltage 2	V_{IH}	$0.7 \times V_{DD}$	$V_{DD} + 0.3$	V	*2
“L” level input voltage 2	V_{IL}	V_{GND}	$0.3 \times V_{DD}$	V	*2
Operating temperature	T_a	-20	+70	°C	

*1 : Input pins excluding TEST and SDR pins.

*2 : TEST and SDR input pins.

WARNING: The recommended operating conditions are required in order to ensure the normal operation of the semiconductor device. All of the device's electrical characteristics are warranted when the device is operated within these ranges.

Always use semiconductor devices within their recommended operating condition ranges. Operation outside these ranges may adversely affect reliability and could result in device failure.

No warranty is made with respect to uses, operating conditions, or combinations not represented on the data sheet. Users considering application outside the listed conditions are advised to contact their representatives beforehand.

■ ELECTRICAL CHARACTERISTICS

1. DC Characteristics

($V_{GND} = 0\text{ V}$, $T_a = -20\text{ °C}$ to $+70\text{ °C}$)

Parameter	Symbol	Pin name	Conditions	Value			Unit
				Min.	Typ.	Max.	
"H" level output voltage	V_{OH}	VC3, VC2, VC1, VC0, BLKC, BLKB, BLKA	$V_{DD} = 3.3\text{ V}$ $I_{OH} = -4\text{ mA}$	$V_{DD} - 0.5$	—	V_{DD}	V
"L" level output voltage	V_{OL}		$V_{DD} = 3.3\text{ V}$ $I_{OL} = 4\text{ mA}$	V_{GND}	—	0.4	V
"H" level input current	I_{IH}	SDR, \overline{HSYNC} , \overline{VSYNC} ,	$V_{DD} = 3.3\text{ V}$ $V_{IH} = V_{DD}$	—	—	+10	μA
"L" level input current	I_{IL}	EXD, TEST, \overline{RESET}	$V_{DD} = 3.3\text{ V}$ $V_{IL} = 0\text{ V}$	—	—	-10	μA
Pull-up resistance	R_{PULL}	SIN, SCLK, \overline{CS}	$V_{DD} = 3.3\text{ V}$	25	50	200	$\text{k}\Omega$
Power supply current	I_{CC}	V_{DD}	$V_{DD} = 2.4\text{ V}$ $f_{DC} = 8\text{ MHz}$	—	—	5	mA
			$V_{DD} = 3.6\text{ V}$ $f_{DC} = 8\text{ MHz}$	—	—	6	mA
Input capacitance	C	Except V_{DD} , GND	—	—	—	16	pF

2. AC Characteristics

(1) Serial input timings

($V_{DD} = 2.4\text{ V to }3.6\text{ V}$, $V_{GND} = 0\text{ V}$, $T_a = -20\text{ }^\circ\text{C to }+70\text{ }^\circ\text{C}$)

Parameter	Symbol	Pin name	Value		Unit
			Min.	Max.	
Shift clock cycle time	t_{CYC}	SCLK	250	—	ns
Shift clock pulse width	t_{WCH}	SCLK	100	—	ns
	t_{WCL}		100	—	ns
Shift clock signal rise/fall time	t_{CR}	SCLK	—	200	ns
	t_{CF}		—	200	ns
Shift clock start time	t_{SS}	SCLK	100	—	ns
Data setup time	t_{SU}	SIN	100	—	ns
Data hold time	t_H		50	—	ns
Chip select end time	t_{EC}	\overline{CS}	100	—	ns
Chip select signal rise/fall time	t_{CRC}	\overline{CS}	—	200	ns
	t_{CFC}		—	200	ns

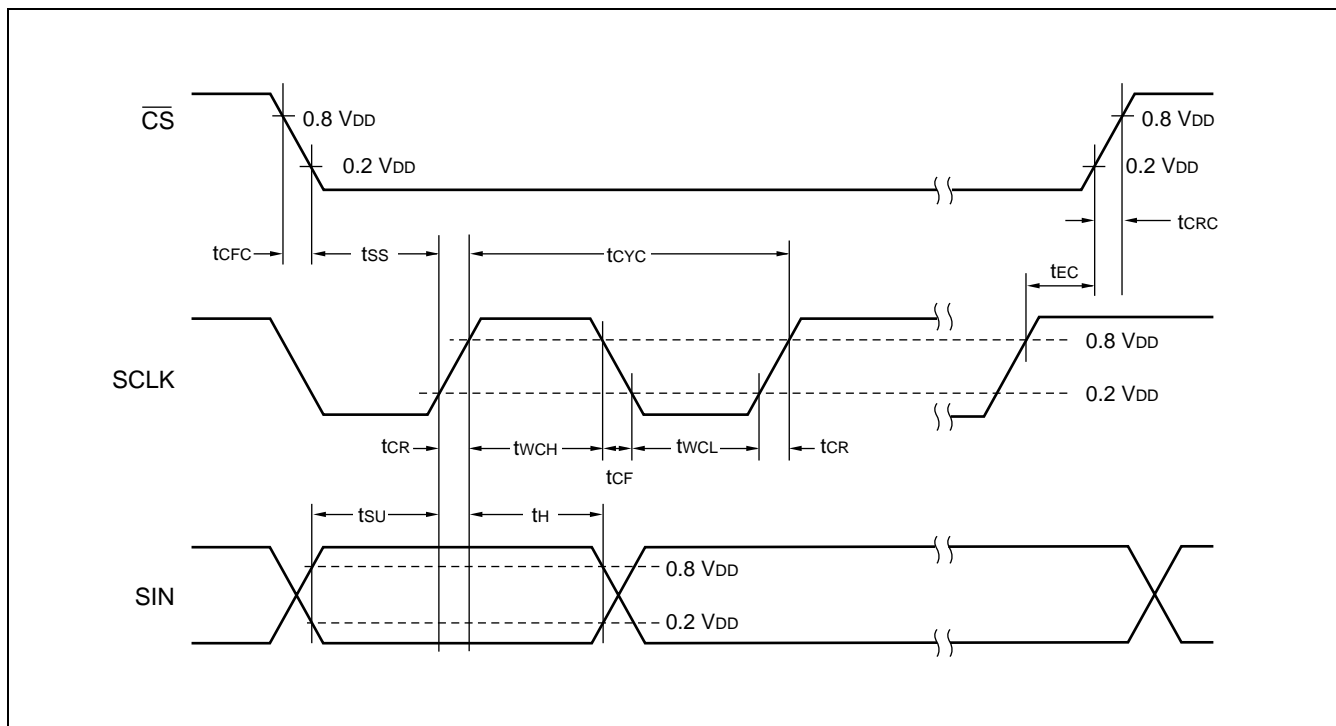

(2) Vertical and horizontal sync signal input timing

($V_{DD} = 2.4\text{ V to }3.6\text{ V}$, $V_{GND} = 0\text{ V}$, $T_a = -20\text{ }^{\circ}\text{C to }+70\text{ }^{\circ}\text{C}$)

Parameter	Symbol	Pin name	Value		Unit
			Min.	Max.	
Horizontal sync signal rise time	t_{HR}	$\overline{\text{HSYNC}}$	—	200	ns
Horizontal sync signal fall time	t_{HF}		—	200	ns
Vertical sync signal rise time	t_{VR}	$\overline{\text{VSYNC}}$	—	200	ns
Vertical sync signal fall time	t_{VF}		—	200	ns
Horizontal sync signal pulse width *1	t_{WH}	$\overline{\text{HSYNC}}$	18	—	Dot clock
			—	6	μs
Vertical sync signal setup time1 *2 (Except for $VVE = 1$, $VHE = 1$, $HE = 1$) *3	t_{VS}	$\overline{\text{VSYNC}}$	4	$1H - 4$	Dot clock
Vertical sync signal setup time2 *2 ($VVE = 1$, $VHE = 1$, $HE = 1$) *3	t_{VS}	$\overline{\text{VSYNC}}$	- 6	$1H - 14$	Dot clock
Vertical sync signal detection hold time	t_{VH}	$\overline{\text{VSYNC}}$	2	—	H
Vertical sync signal pulse width	t_{wv}	$\overline{\text{VSYNC}}$	2	20	H

*1 : During the horizontal sync signal pulse period, the MB90099 stops its internal operation, disabling writing to the internal VRAM. Therefore, the horizontal sync signal pulse width and VRAM write cycle (command 2 or command 4 issuance cycle) should be set so that the horizontal sync signal pulse width is shorter than the VRAM write cycle.

*2 : In the vertical sync signal detection cycle, do not change the vertical sync signal (detection edge) when it is close to the horizontal sync signal edge. This may result in distortion of the display due to fluctuations in the sync signal.

*3 : VVE , VHE and HE are control bits of Command 13-0 (I/O pin control) .

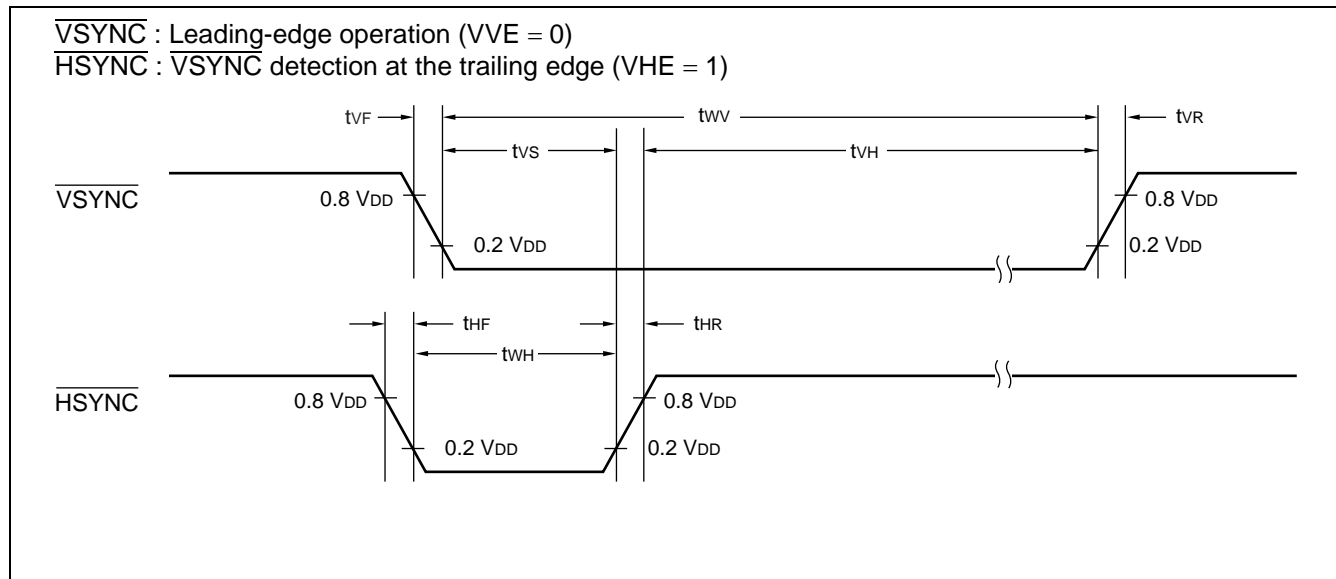

(Continued)

(Continued)

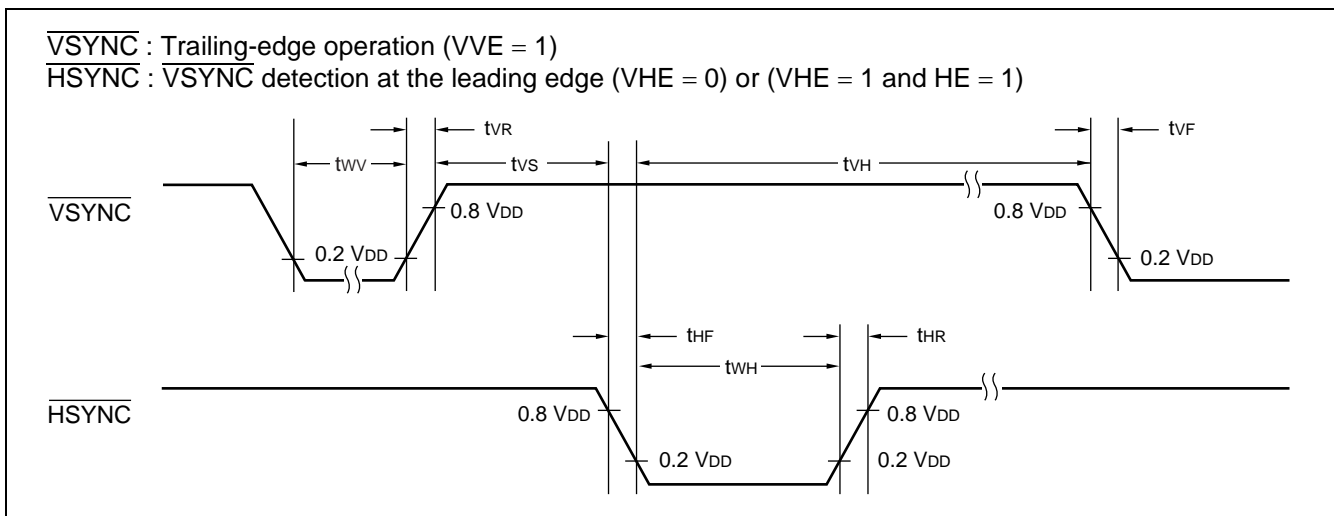
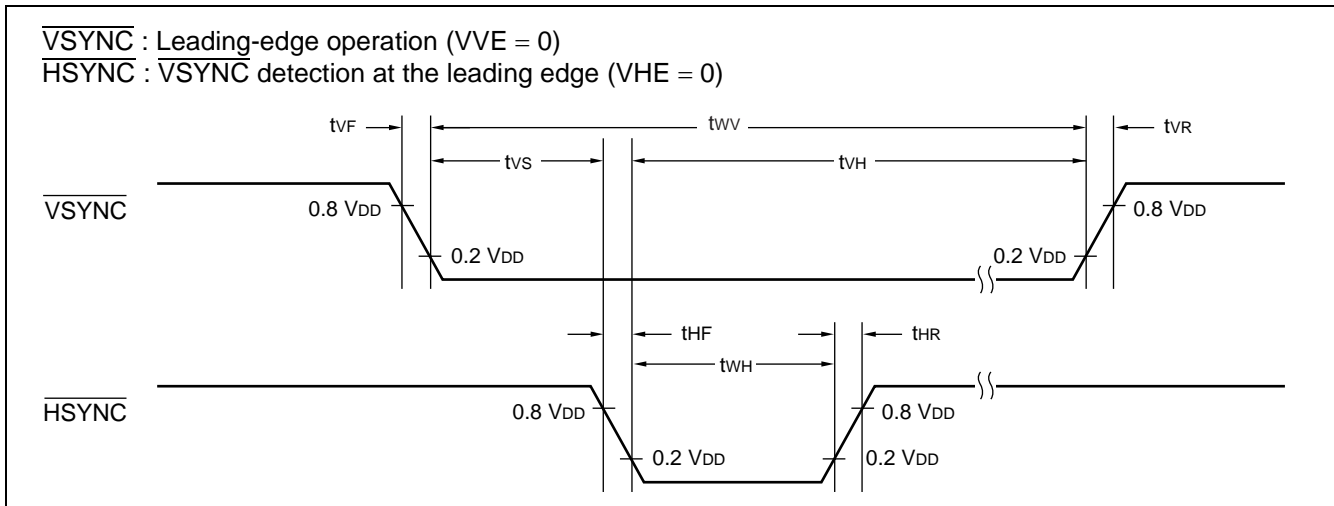
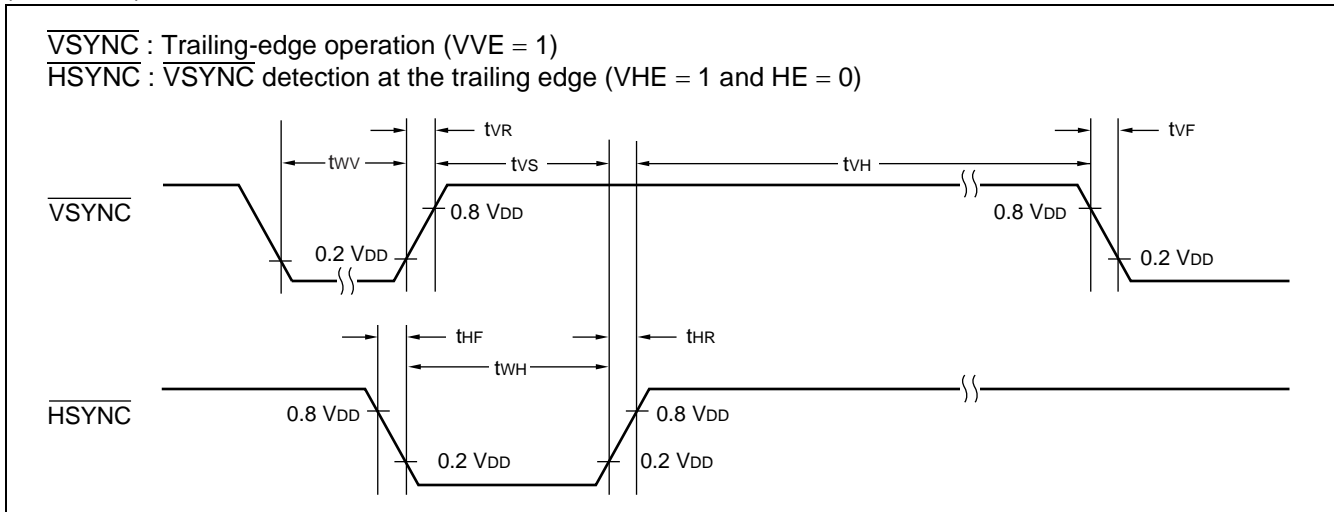

Note : The above diagrams assume that I/O pin control command (command 13-0) has set the sync signal input logic control setting (SIX bit) to negative logic ("0") . However, if the positive logic setting (SIX bit = "1") is used, the H and L levels are reversed.

(3) Dot clock external input timing

($V_{DD} = 2.7\text{ V to }3.3\text{ V}$, $V_{GND} = 0\text{ V}$, $T_a = -20\text{ }^\circ\text{C to }+70\text{ }^\circ\text{C}$)

Parameter	Symbol	Pin name	Value		Unit	Note
			Min.	Max.		
Dot clock cycle time	t_{DCYC1}	EXD	112	166	ns	*1
	t_{DCYC2}	EXD	56	83	ns	*2
Dot clock pulse time	t_{DWH1}	EXD	48	—	ns	*1
	t_{DWL1}		48	—	ns	
	t_{DWH2}	EXD	24	—	ns	*2
	t_{DWL2}		24	—	ns	
$\overline{\text{HSYNC}}$, $\overline{\text{VSYNC}}$ setup time	t_{DS}	$\overline{\text{HSYNC}}$, $\overline{\text{VSYNC}}$	13	—	ns	*3
$\overline{\text{HSYNC}}$, $\overline{\text{VSYNC}}$ hold time	t_{DH}		0	—	ns	*3
Data output delay time 1	t_{DD1}	VC3, VC2, VC1, VC0, BLKA, BLKB, BLKC	7	t_{DD2}	ns	*3
Data output delay time 2	t_{DD2}		t_{DD1}	45	ns	

Note : The above items assume a supply voltage of $V_{DD} = 2.7\text{ V to }3.3\text{ V}$.

*1 : Assuming input frequency = dot clock \times 1.

*2 : Assuming input frequency = dot clock \times 2.

*3 : Assuming input frequency = dot clock \times 1 or dot clock \times 2.

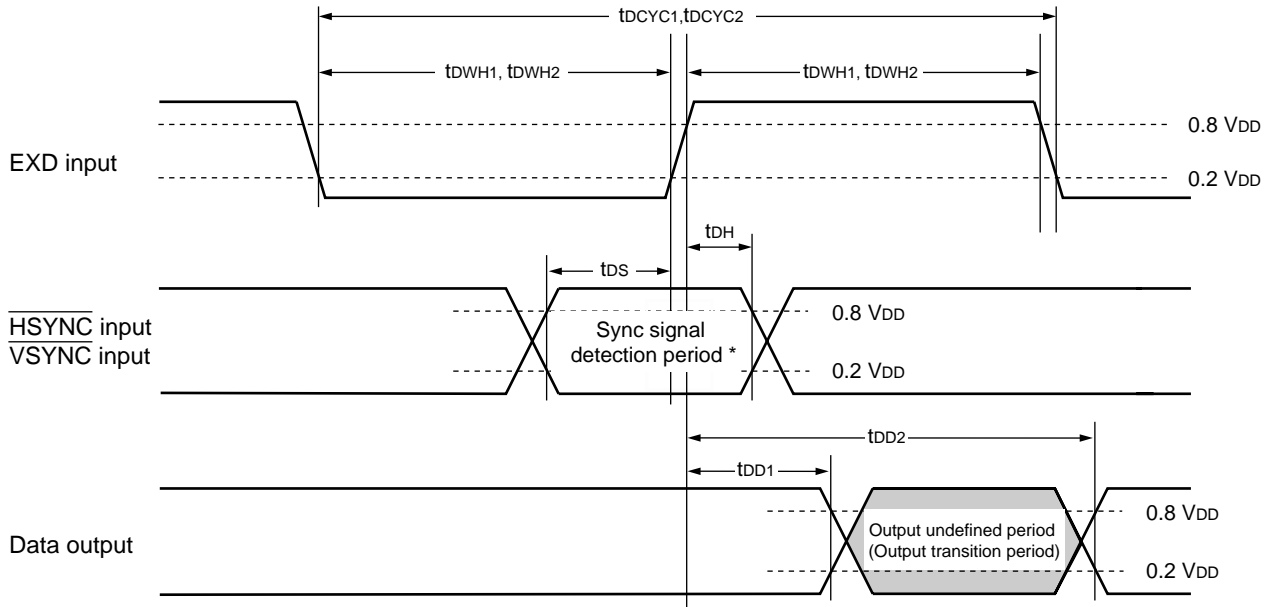

AC measurement conditions

$C = 70 \text{ pF}$ $V_{OH} = 0.8 V_{DD}$
 $t_r = 5 \text{ ns}$ $V_{OL} = 0.2 V_{DD}$
 $t_f = 5 \text{ ns}$ $V_{IH} = 0.8 V_{DD}$
 $V_{IL} = 0.2 V_{DD}$

* : Do not vary the input sync signal during the sync signal detection period.
 Changes in the signal during this period may cause distortion in the display.

(4) Reset input timing

($V_{DD} = 2.4\text{ V to }3.6\text{ V}$, $V_{GND} = 0\text{ V}$, $T_a = -20\text{ }^{\circ}\text{C to }+70\text{ }^{\circ}\text{C}$)

Parameter	Symbol	Pin name	Value		Unit	Note
			Min.	Max.		
Reset pulse width	t_{WRST}	$\overline{\text{RESET}}$	1	—	μs	
Clock input	t_{WRSD}	EXD	5	—	Dot clock	*

* : Clock input is required during reset.

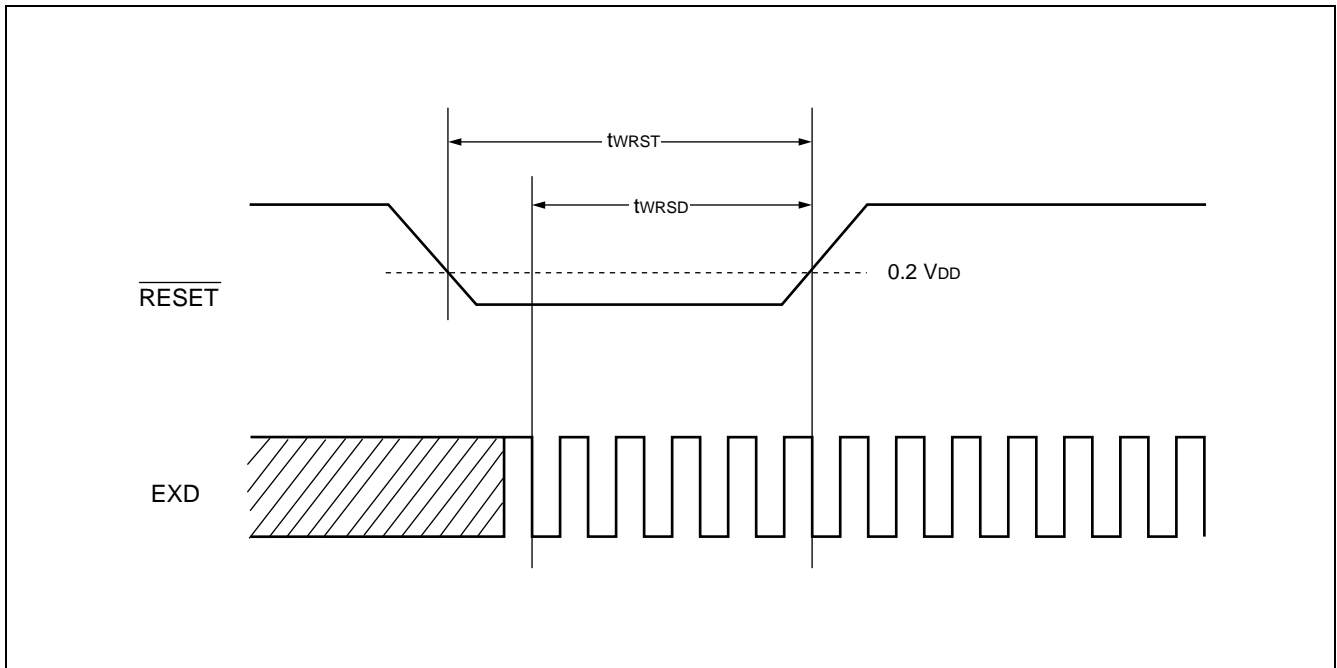

■ DISPLAY CONTROL COMMANDS

1. Command list

Command no.	Function	Command code/data												
		15 to 12	11	10	9	8	7	6	5	4	3	2	1	0
0	VRAM write address setting	0 0 0 0	AY3	AY2	AY1	AY0	FL	0	0	AX4	AX3	AX2	AX1	AX0
1	Character data setting 1	0 0 0 1	MO1	MO0	MM1	MM0	MB3	MB2	MB1	MB0	MC3	MC2	MC1	MC0
2	Character data setting 2	0 0 1 0	MR	MS	M9	M8	M7	M6	M5	M4	M3	M2	M1	M0
3	Line control data setting 1	0 0 1 1	LHS	LW2	LW1	LW0	LFD	LFC	LFB	LFA	LF3	LF2	LF1	LF0
4	Line control data setting 2	0 1 0 0	LDS	LGS	LG1	LG0	LD	LE	LM1	LM0	L3	L2	L1	L0
5-00	Screen output control 1A	0 1 0 1	0	0	0	0	SDS	UDS	0	DSP	0	OA2	OA1	OA0
5-01	Screen output control 1B	0 1 0 1	0	0	0	1	SOB	BGB	BLB	0	0	OB2	OB1	OB0
5-02	Screen output control 1C	0 1 0 1	0	0	1	0	SOC	BGC	BLC	0	0	OC2	OC1	OC0
5-2	Vertical display position control	0 1 0 1	1	0	0	Y8	Y7	Y6	Y5	Y4	Y3	Y2	Y1	Y0
5-3	Horizontal display position control	0 1 0 1	1	1	0	X8	X7	X6	X5	X4	X3	X2	X1	X0
6-1	Shaded background frame color control	0 1 1 0	0	1	0	0	BH3	BH2	BH1	BH0	BS3	BS2	BS1	BS0
7-3	Screen background control	0 1 1 1	1	1	0	0	0	0	0	0	U3	U2	U1	U0
8-0	Sprite character control 1	1 0 0 0	0	0	SFB	SFA	SF3	SF2	SF1	SF0	SC3	SC2	SC1	SC0
8-1	Sprite character control 2	1 0 0 0	0	1	SD1	SD0	SM7	SM6	SM5	SM4	SM3	SM2	SM1	SM0
9-0	Sprite character control 4	1 0 0 1	0	0	SY9	SY8	SY7	SY6	SY5	SY4	SY3	SY2	SY1	SY0
9-1	Sprite character control 5	1 0 0 1	1	0	SX9	SX8	SX7	SX6	SX5	SX4	SX3	SX2	SX1	SX0
11-0	Screen extension control	1 0 1 1	0	0	0	0	0	EG0	0	0	0	0	0	0
11-2	Dot clock control 1	1 0 1 1	1	0	0	0	0	0	0	0	0	DC2	DC1	DC0

(Continued)

MB90099

(Continued)

Command no.	Function	Command code/data												
		15 to 12	11	10	9	8	7	6	5	4	3	2	1	0
13-0	I/O pin control	1 1 0 1	0	0	VVE	VHE	HE	0	SIX	0	0	0	DBX	DCX
13-1	Horizontal blanking control 1	1 1 0 1	0	1	0	0	0	0	BB5	BB4	BB3	BB2	BB1	BB0
13-2	Horizontal blanking control 2	1 1 0 1	1	0	0	BF8	BF7	BF6	BF5	BF4	BF3	BF2	BF1	BF0

2. Command Description

• Command 0 (VRAM write address setting)

Command 0 sets the write address in VRAM, and controls the execution of “VRAM fill”. The write address is specified by row and column addresses. VRAM fill is activated by executing character data setting 2 (command 2).

15	14	13	12	11	10	9	8	7	6	5	4	3	2	1	0
0	0	0	0	AY3	AY2	AY1	AY0	FL	0	0	AX4	AX3	AX2	AX1	AX0

AY3 to AY0 : Row address (0 to B_H)

AX4 to AX0 : Column address (0 to 1B_H)

FL : VRAM Fill control (0 : OFF, 1 : ON)

• Command 1 (Character data setting 1)

Command 1 specifies character data. The character data is written to VRAM and reflected on the screen by the execution of command 2 (character data setting 2).

15	14	13	12	11	10	9	8	7	6	5	4	3	2	1	0
0	0	0	1	MO1	MO0	MM1	MM0	MB3	MB2	MB1	MB0	MC3	MC2	MC1	MC0

MO1, MO0 : Character output control

MM1, MM0 : Character background control

(0, 0 : Off)

(0, 1 : Solid fill)

(1, 0 : Concaved shaded)

(1, 1 : Convexed shaded)

MC3 to MC0 : Character color (16 colors)

MB3 to MB0 : Background color (16 colors)

• Command 2 (Character data setting 2)

Command 2 writes additional character data to the location in VRAM specified by command 0 (VRAM write address setting), along with the character data set by command 1 (character data setting 1).

The VRAM write address is automatically incremented after command 2 is executed.

15	14	13	12	11	10	9	8	7	6	5	4	3	2	1	0
0	0	1	0	MR	MS	M9	M8	M7	M6	M5	M4	M3	M2	M1	M0

MR : Shaded background succeeding character merge control

(0 : Not merged with succeeding character)

(1 : Merged with succeeding character)

MS : Character horizontal size control

(0 : S size, 6 dots)

(1 : L size, 12 dots)

M9 to M0 : Character code

• Command 3 (Line control data setting 1)

Command 3 specifies line control data. The line control data is written to VRAM and reflected on the screen by the execution of command 4 (line control data setting 2) .

15	14	13	12	11	10	9	8	7	6	5	4	3	2	1	0
0	0	1	1	LHS	LW2	LW1	LW0	LFD	LFC	LFB	LFA	LF3	LF2	LF1	LF0

LHS : Line character vertical size type control

- (0 : Character vertical size A)
- (1 : Character vertical size B)

LW2 to LW0 : Line spacing control

- (0 to 7 dots, in 1-dot units)

LF3 to LF0 : Trimming color (16 colors)

LFD, LFC : Trimming output control

- (0, 0 : All Off)
- (0, 1 : Trimming On for a character only, no character background)
- (1, 0 : Trimming On for a solid-fill character or no character background)
- (1, 1 : All On)

LFB, LFA : Trimming control

- (0, 0 : Trimming Off)
- (0, 1 : Reserved (setting prohibited))
- (1, 0 : Reserved (setting prohibited))
- (1, 1 : Eight-direction trimming)

• Command 4 (Line control data setting 2)

Command 4 specifies additional line control data and writes this data, along with the line control data set by command 3 (line control data setting 1) to the row address in VRAM specified by command 0 (VRAM write address setting) .

Executing this command will not alter the VRAM write address.

15	14	13	12	11	10	9	8	7	6	5	4	3	2	1	0
0	1	0	0	LDS	LGS	LG1	LG0	LD	LE	LM1	LM0	L3	L2	L1	L0

LDS : Line character output control (control of a character + trimming + character background)

- (0 : Off, 1 : On)

LGS : Line enlargement interpolation control

- (0 : Off, 1 : On)

LG1, LG0 : Line enlargement control

- (0, 0 : Normal)
- (0, 1 : Double width)
- (1, 0 : Double height)
- (1, 1 : Double width × double height)

LE : Character background extension control

- (0 : Normal, 1 : Extended)

LD : Shaded background succeeding line merge control

- (0 : Independent)
- (1 : Merged with succeeding line)

LM1, LM0 : Line background control

(0, 0 : Off)

(0, 1 : Solid fill)

(1, 0 : Concaved shaded)

(1, 1 : Convexed shaded)

L3 to L0 : Line background color (16 colors)

• Command 5-00 (Screen output control 1A)

Command 5-00 controls screen display output.

15	14	13	12	11	10	9	8	7	6	5	4	3	2	1	0
0	1	0	1	0	0	0	0	SDS	UDS	0	DSP	0	OA2	OA1	OA0

SDS : Sprite character output control

(0 : Off, 1 : On) *

UDS : Screen background output control

(0 : Off, 1 : On) *

DSP : Display output control (Control of a character + trimming + character background + line background)

(0 : Off, 1 : On) *

OA2 to OA0 : Output-A character control (8 types)

* : Input of an 'L' level signal to the $\overline{\text{RESET}}$ pin will initialize SDS = 0, UDS = 0, and DSP = 0.

• Command 5-01 (Screen output control 1B)

Command 5-01 controls output-B screen display output.

15	14	13	12	11	10	9	8	7	6	5	4	3	2	1	0
0	1	0	1	0	0	0	1	SOB	BGB	BLB	0	0	OB2	OB1	OB0

SOB : Output-B sprite character output control

(0 : Off, 1 : On)

BGB : Output-B screen background output control

(0 : Off, 1 : On)

BLB : Output-B line background output control

(0 : Off, 1 : On)

OB2 to OB0 : Output-B character control (8 types)

- **Command 5-02 (Screen output control 1C)**

Command 5-02 controls output-C screen display output.

15	14	13	12	11	10	9	8	7	6	5	4	3	2	1	0
0	1	0	1	0	0	1	0	SOC	BGC	BLC	0	0	OC2	OC1	OC0

SOC : Output-C sprite character output control
(0 : Off, 1 : On)

BGC : Output-C screen background output control
(0 : Off, 1 : On)

BLC : Output-C line background output control
(0 : Off, 1 : On)

OC2 to OC0 : Output-C character control (8 types)

- **Command 5-2 (Vertical display position control)**

Command 5-2 controls the vertical display position on the screen.

15	14	13	12	11	10	9	8	7	6	5	4	3	2	1	0
0	1	0	1	1	0	0	Y8	Y7	Y6	Y5	Y4	Y3	Y2	Y1	Y0

Y8 to Y0 : Vertical display position control (0 to 1022 in 2-dot units)

- **Command 5-3 (Horizontal display position control)**

Command 5-3 controls the horizontal display position on the screen.

15	14	13	12	11	10	9	8	7	6	5	4	3	2	1	0
0	1	0	1	1	1	0	X8	X7	X6	X5	X4	X3	X2	X1	X0

X8 to X0 : Horizontal display position control (0 to 1022 in 2-dot units)

- **Command 6-1 (Shaded background frame color control)**

Command 6-1 controls the frame color of the shaded background.

15	14	13	12	11	10	9	8	7	6	5	4	3	2	1	0
0	1	1	0	0	1	0	0	BH3	BH2	BH1	BH0	BS3	BS2	BS1	BS0

BH3 to BH0 : Shaded background frame highlight color (16 colors)

BS3 to BS0 : Shaded background frame shadow color (16 colors)

- **Command 7-3 (Screen background control)**

Command 7-3 controls the screen background color.

15	14	13	12	11	10	9	8	7	6	5	4	3	2	1	0
0	1	1	1	1	1	0	0	0	0	0	0	U3	U2	U1	U0

U3 to U0 : Screen background color (16 colors)

• Command 8-0 (Sprite character control 1)

Command 8-0 controls sprite characters.

15	14	13	12	11	10	9	8	7	6	5	4	3	2	1	0
1	0	0	0	0	0	SFB	SFA	SF3	SF2	SF1	SF0	SC3	SC2	SC1	SC0

SFB, SFA : Sprite character trimming control

(0, 0 : Trimming Off)

(0, 1 : Reserved)

(1, 0 : Reserved)

(1, 1 : Eight-direction trimming)

SF3 to SF0 : Sprite character trimming color (16 colors)

SC3 to SC0 : Sprite character color (16 colors)

• Command 8-1 (Sprite character control 2)

Command 8-1 controls sprite characters.

15	14	13	12	11	10	9	8	7	6	5	4	3	2	1	0
1	0	0	0	0	1	SD1	SD0	SM7	SM6	SM5	SM4	SM3	SM2	SM1	SM0

SD1, SD0 : Sprite character configuration control

(0, 0 : 1 character)

(0, 1 : Reserved (setting prohibited))

(1, 0 : Stack of 2 characters)

(1, 1 : Reserved (setting prohibited))

SM7 to SM0 : Sprite character code

(000_H to 0FF_H for 256 different characters)

• Command 9-0 (Sprite character control 4)

Command 9-0 controls the vertical display position of sprite characters.

15	14	13	12	11	10	9	8	7	6	5	4	3	2	1	0
1	0	0	1	0	0	SY9	SY8	SY7	SY6	SY5	SY4	SY3	SY2	SY1	SY0

SY9 to SY0 : Sprite character vertical display position control

(0 to 1023 in 1-dot units)

• Command 9-1 (Sprite character control 5)

Command 9-1 controls the horizontal display position of sprite characters.

15	14	13	12	11	10	9	8	7	6	5	4	3	2	1	0
1	0	0	1	1	0	SX9	SX8	SX7	SX6	SX5	SX4	SX3	SX2	SX1	SX0

SX9 to SX0 : Sprite character horizontal display position control

(0 to 1023 in 1-dot units)

• **Command 11-0 (Screen extension control)**

(Reserved)

15	14	13	12	11	10	9	8	7	6	5	4	3	2	1	0
1	0	1	1	0	0	0	0	0	EG0	0	0	0	0	0	0

EG0 : (Reserved)

(0 : Normal)

(1 : Reserved (setting prohibited))

• **Command 11-2 (Dot clock control 1)**

Command 11-2 controls dot clock selection.

15	14	13	12	11	10	9	8	7	6	5	4	3	2	1	0
1	0	1	1	1	0	0	0	0	0	0	0	0	DC2	DC1	DC0

DC2 to DC0 : Dot clock selection control

(0, 1, 0) : External dot clock input

(0, 1, 1) : Frequency-doubled external dot clock input

• **Command 13-0 (I/O pin control)**

Command 13-0 controls I/O pin functions.

15	14	13	12	11	10	9	8	7	6	5	4	3	2	1	0
1	1	0	1	0	0	VVE	VHE	HE	0	SIX	0	0	0	DBX	DCX

VVE : Edge selection for vertical synchronization detection*1

(0 : Leading edge, 1 : Trailing edge)

VHE : HSYNC edge selection for vertical synchronization detection*1

(0 : Leading edge, 1 : Trailing edge)

HE : Edge selection for horizontal synchronization operation*1

(0 : Trailing edge, 1 : Leading edge)

SIX : Logic control for sync signal input

(0 : Negative logic, 1 : Positive logic)

DCX : Logic control for display color signal output

(0 : Positive logic, 1 : Negative logic) *2

DBX : Logic control for display output period signal

(0 : Positive logic, 1 : Negative logic) *2

*1 : When it is set up VVE = 1, VHE = 1 and HE = 1, the vertical sync detection HSYNC edge is the standard of "Leading edge".

VVE	VHE	HE	Contents of vertical sync detection	Position of vertical sync detection*
0	0	0	Detection of VSYNC Leading edge	HSYNC Leading edge
0	0	1	Detection of VSYNC Leading edge	HSYNC Leading edge
0	1	0	Detection of VSYNC Leading edge	HSYNC Trailing edge
0	1	1	Detection of VSYNC Leading edge	HSYNC Trailing edge
1	0	0	Detection of VSYNC Trailing edge	HSYNC Leading edge
1	0	1	Detection of VSYNC Trailing edge	HSYNC Leading edge
1	1	0	Detection of VSYNC Trailing edge	HSYNC Trailing edge
1	1	1	Detection of VSYNC Trailing edge	HSYNC Leading edge + 10 clock

* : If there is the change of level for direction of VSYNC pin signal detection in the vicinity of vertical sync detection, it may occur disorder in the display (deflection of vertical direction) . Input the meaningful edge of VSYNC signal without this position of vertical sync detection.

*2 : Input of an 'L' level signal to the $\overline{\text{RESET}}$ pin will initialize DCX = 0, and DBX = 0.

• Command 13-1 (Horizontal blanking control 1)

Command 13-1 controls the back porch of the horizontal blanking function.

15	14	13	12	11	10	9	8	7	6	5	4	3	2	1	0
1	1	0	1	0	1	0	0	0	0	BB5	BB4	BB3	BB2	BB1	BB0

BB5 to BB0 : Back porch control (0 to 126, in 2-dot units)

• Command 13-2 (Horizontal blanking control 2)

Command 13-2 controls the front porch of the horizontal blanking function.

15	14	13	12	11	10	9	8	7	6	5	4	3	2	1	0
1	1	0	1	1	0	0	BF8	BF7	BF6	BF5	BF4	BF3	BF2	BF1	BF0

BF8 to BF0 : Front porch control (0 to 1022, in 2-dot units)

3. Notes on Issuing Commands

(1) Initialization

When a reset signal is input ("L" level signal input to the $\overline{\text{RESET}}$ pin), the MB90099 enters display-off state(*). The contents of VRAM (the character RAM and the line RAM) are undefined.

Immediately after release of the input signal to the MB90099, issue the following commands to initialize control operation.

- Dot clock control 1 (command 11-2)
- I/O pin control (command 13-0)

This must be done before setting all command data and all RAM contents. (VRAM settings require normal dot clock input and normal sync signal input.)

* : The reset input initializes control bits as follows.

Screen output control 1A (command 5-00)

SDS = 0 Sprite Off

UDS = 0 Screen background Off

DSP = 0 Character, character background, line background Off

I/O pin control (command 13-0)

DCX = 0 VC0, VC1, VC2, VC3 pins set to positive logic output

DBX = 0 BLKA, BLKB, BLKC pins set to positive logic output

(2) Command refresh

Command data to the MB90099 and the contents of internal VRAM are stored as long as power is supplied to the MB90099. However, there may be cases in which the serial control, sync, or dot clock signals become abnormal due to causes such as external noise, preventing the internal registers and VRAM from being set properly. It is therefore recommended that all command data and VRAM data be refreshed periodically to ensure that this data is correct.

(3) Command issue timing

When any control command, including a VRAM write command such as a character data setting or line control data setting command is issued, the command is executed immediately and the result is reflected on the screen. When such a command is issued during a display period, the display in the relevant field may experience momentary distortion. To avoid this, it is recommended that commands be issued during the vertical blanking interval. However that with a command 5-00 (screen output control 1A) in which one or more of the DSP, SDS, or UDS control bits is switched from OFF to ON, the display will wait until the next vertical sync signal after the command is issued and the display will start from the top of the scanning field.

■ CONTENTS OF MB90099-001 (STANDARD PRODUCT) FONT DATA

0	1	2	3	4	5	6	7	8	9	:	:	?	!	.	.
000	001	002	003	004	005	006	007	008	009	00A	00B	00C	00D	00E	00F
A	B	C	D	E	F	G	H	I	J	K	L	M	N	O	P
010	011	012	013	014	015	016	017	018	019	01A	01B	01C	01D	01E	01F
Q	R	S	T	U	V	W	X	Y	Z	()	()	[]
020	021	022	023	024	025	026	027	028	029	02A	02B	02C	02D	02E	02F
a	b	c	d	e	f	g	h	i	j	k	l	m	n	o	p
030	031	032	033	034	035	036	037	038	039	03A	03B	03C	03D	03E	03F
q	r	s	t	u	v	w	x	y	z	+	-	*	/	=	¥
040	041	042	043	044	045	046	047	048	049	04A	04B	04C	04D	04E	04F
0	1	2	3	4	5	6	7	8	9	”	’	#	\$	%	&
050	051	052	053	054	055	056	057	058	059	05A	05B	05C	05D	05E	05F
A	B	C	D	E	F	G	H	I	J	K	L	M	N	O	P
060	061	062	063	064	065	066	067	068	069	06A	06B	06C	06D	06E	06F
Q	R	S	T	U	V	W	X	Y	Z	f	i	j	l	t	~
070	071	072	073	074	075	076	077	078	079	07A	07B	07C	07D	07E	07F
0	1	2	3	4	5	6	7	8	9	:	:	?	!	.	.
080	081	082	083	084	085	086	087	088	089	08A	08B	08C	08D	08E	08F
A	B	C	D	E	F	G	H	I	J	K	L	M	N	O	P
090	091	092	093	094	095	096	097	098	099	09A	09B	09C	09D	09E	09F
Q	R	S	T	U	V	W	X	Y	Z	PH	PH	o	^	P	P
0A0	0A1	0A2	0A3	0A4	0A5	0A6	0A7	0A8	0A9	0AA	0AB	0AC	0AD	0AE	0AF
Ç	ü	é	â	ä	à	ä	ç	ê	ë	è	ï	î	ï	À	Á
0B0	0B1	0B2	0B3	0B4	0B5	0B6	0B7	0B8	0B9	0BA	0BB	0BC	0BD	0BE	0BF
É	æ	Æ	ô	ö	ò	û	ù	ÿ	Ö	Ü	Ö	Æ	R	f	j
0C0	0C1	0C2	0C3	0C4	0C5	0C6	0C7	0C8	0C9	0CA	0CB	0CC	0CD	0CE	0CF
á	í	ó	ú	ñ	Ñ	ı	ı	ı	ı	ı	ı	ı	ı	ı	ı
0D0	0D1	0D2	0D3	0D4	0D5	0D6	0D7	0D8	0D9	0DA	0DB	0DC	0DD	0DE	0DF
T															
0E0	0E1	0E2	0E3	0E4	0E5	0E6	0E7	0E8	0E9	0EA	0EB	0EC	0ED	0EE	0EF
▶	▶	▶	▶	●	ı	ı	ı	ı	ı	○	●	▲	▼	■	
0F0	0F1	0F2	0F3	0F4	0F5	0F6	0F7	0F8	0F9	0FA	0FB	0FC	0FD	0FE	0FF

あ	い	う	え	お	か	き	く	け	こ	さ	し	す	せ	そ	た
110	111	112	113	114	115	116	117	118	119	11A	11B	11C	11D	11E	11F
ち	つ	て	と	な	に	ぬ	ね	の	は	ひ	ふ	へ	ほ	ま	み
120	121	122	123	124	125	126	127	128	129	12A	12B	12C	12D	12E	12F
ア	イ	ウ	エ	オ	カ	キ	ク	ケ	コ	サ	シ	ス	セ	ソ	タ
130	131	132	133	134	135	136	137	138	139	13A	13B	13C	13D	13E	13F
手	ツ	テ	ト	ナ	ニ	ヌ	ネ	ノ	ハ	ヒ	フ	ヘ	ホ	マ	ミ
140	141	142	143	144	145	146	147	148	149	14A	14B	14C	14D	14E	14F
ム	メ	モ	ヤ	ユ	ヨ	ラ	リ	ル	レ	ロ	ワ	ヅ	ヅ	ヅ	ヅ
150	151	152	153	154	155	156	157	158	159	15A	15B	15C	15D	15E	15F
あ	い	う	え	お	や	ゆ	よ	ア	イ	ウ	エ	オ	カ	キ	ク
160	161	162	163	164	165	166	167	168	169	16A	16B	16C	16D	16E	16F
抗	張	機	能	ノ	ノ	ノ	ノ	ノ	ノ	ノ	ノ	ノ	ノ	ノ	ノ
170	171	172	173	174	175	176	177	178	179	17A	17B	17C	17D	17E	17F
日	月	火	木	木	金	土	年	曜	時	分	秒	録	画	再	生
180	181	182	183	184	185	186	187	188	189	18A	18B	18C	18D	18E	18F
早	送	巻	戻	停	止	毎	週	予	約	間	始	終	了	設	定
190	191	192	193	194	195	196	197	198	199	19A	19B	19C	19D	19E	19F
標	準	倍	入	力	音	声	主	副	左	右	夷	行	確	認	自
1A0	1A1	1A2	1A3	1A4	1A5	1A6	1A7	1A8	1A9	1AA	1AB	1AC	1AD	1AE	1AF
動	選	規	運	会	祝	学	卒	業	武	芸	富	士	通	文	字
1B0	1B1	1B2	1B3	1B4	1B5	1B6	1B7	1B8	1B9	1BA	1BB	1BC	1BD	1BE	1BF
行	面	背	景	凹	凸	平	垂	直	表	示	位	置	間	隔	色
1C0	1C1	1C2	1C3	1C4	1C5	1C6	1C7	1C8	1C9	1CA	1CB	1CC	1CD	1CE	1CF
縦	横	単	影	付	種	系	統	出	制	額	牌	信	号	補	刻
1D0	1D1	1D2	1D3	1D4	1D5	1D6	1D7	1D8	1D9	1DA	1DB	1DC	1DD	1DE	1DF
午	前	後	申	切	大	師	師	師	師	師	師	師	師	師	師
1E0	1E1	1E2	1E3	1E4	1E5	1E6	1E7	1E8	1E9	1EA	1EB	1EC	1ED	1EE	1EF
師	師	師	師	師	師	師	師	師	師	師	師	師	師	師	師
1F0	1F1	1F2	1F3	1F4	1F5	1F6	1F7	1F8	1F9	1FA	1FB	1FC	1FD	1FE	1FF

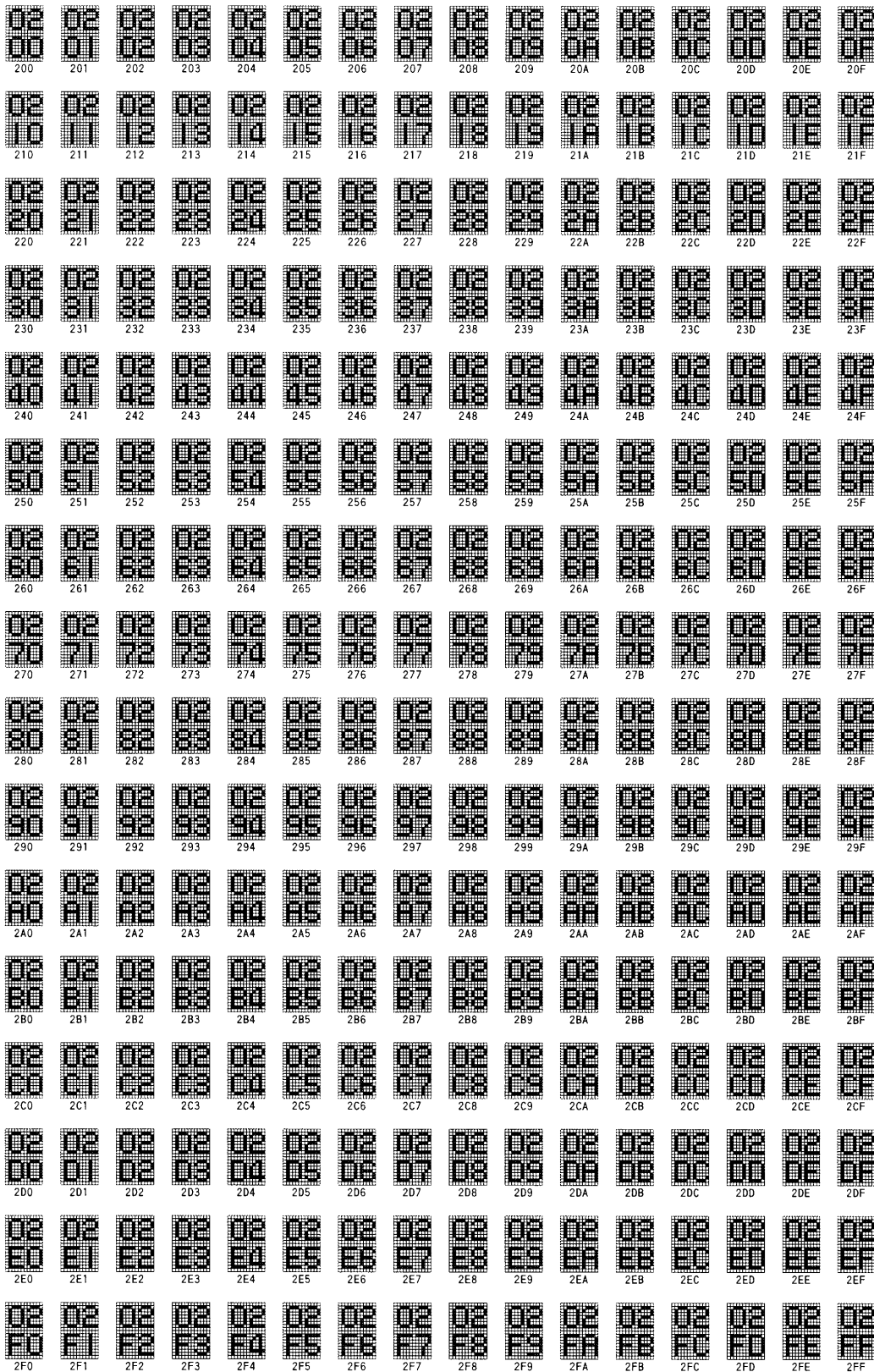

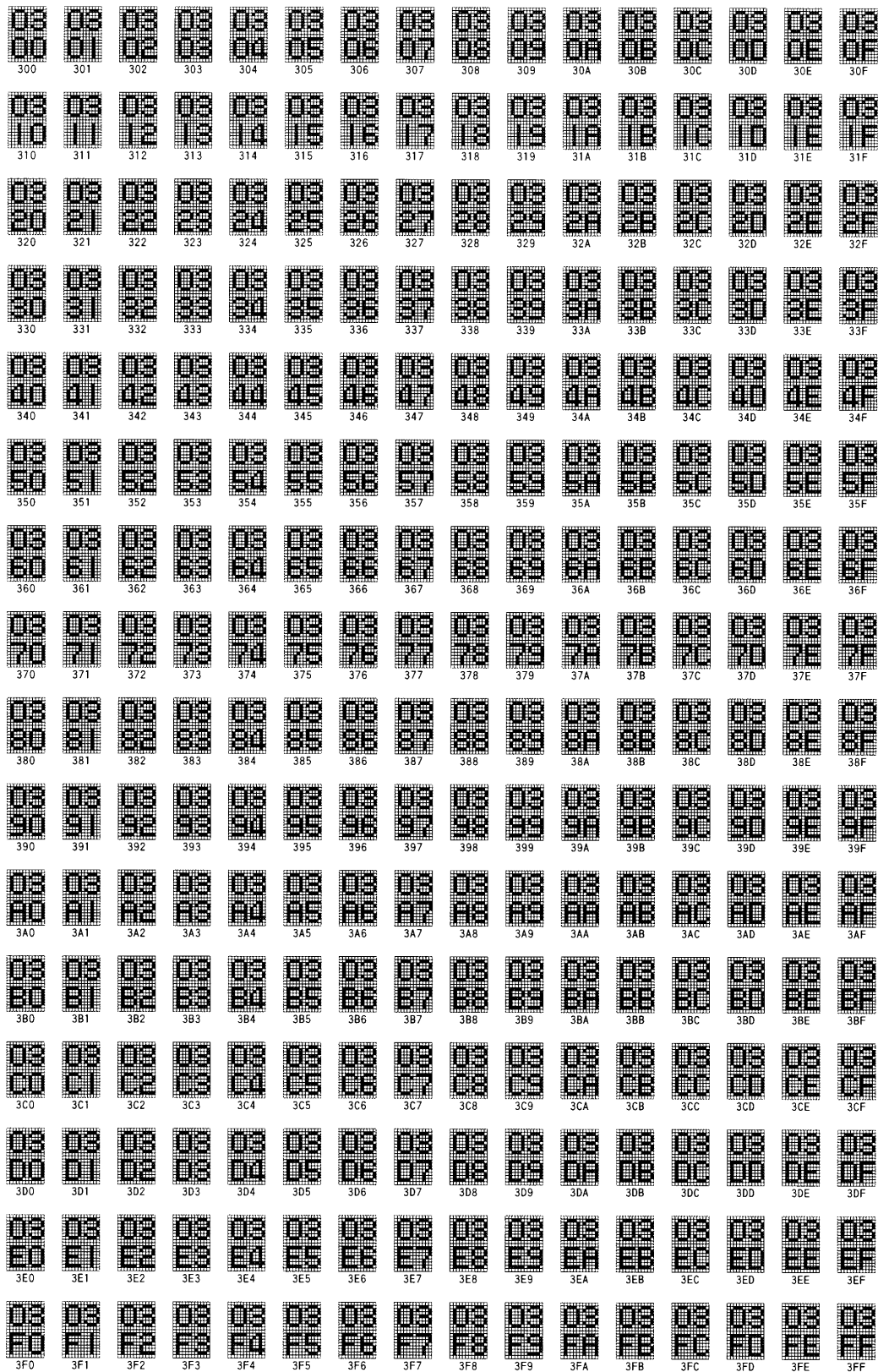

■ FONT DEVELOPMENT AND DATA RELEASE

The MB90099 features the font ROM in which all 1024 characters are user-definable. For font data development, use the OSDC pattern editor Ped/Win. Ped/Win is an OSDC proprietary pattern editor for use on personal computers operating Windows95/98/NT4.0 (Japanese language) environments.

The font development and data release flow is illustrated below.

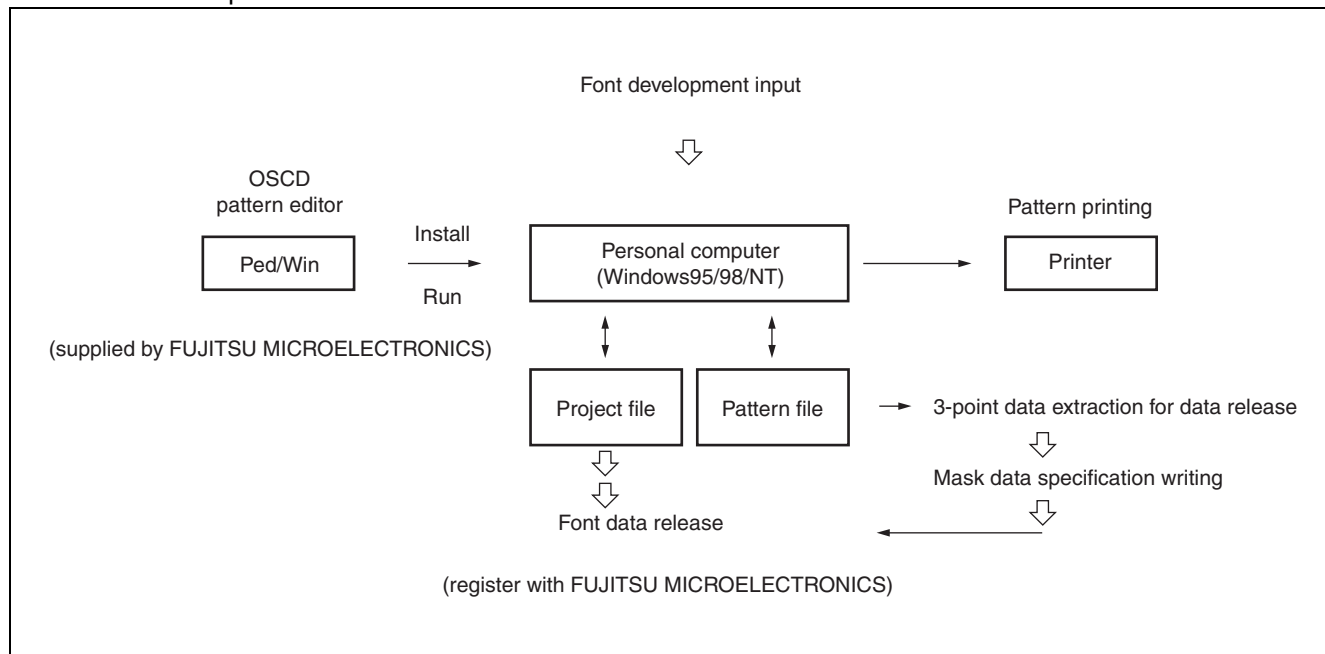

(1) Font data release

Font data is released in project files only. Pattern files should not be released. A portion of the pattern file data will be used for data matching in order to verify registration of release data by FUJITSU MICROELECTRONICS. For this reason, users are requested to write a portion of the pattern data content in mask data specifications.

Note : Pattern data output should not be generated until after the completion of font creation and project creation.

Also, the project file should not be updated after pattern file generation is completed. If the project contents are updated after pattern file generation, pattern files should be generated again.

(2) Project files

After font data and other supplementary data is created, it is stored in a project file. Normally one project file is created for each model.

• Project file names

Project file names should be in the format "MB90099-XXX" where "XXX" is a ROM number assigned by FUJITSU MICROELECTRONICS. Users should contact their FUJITSU MICROELECTRONICS sales representative. If no ROM number has been assigned, any number preceded by an alphabetic character may be used. Project files which are developed solely for test purposes and not intended for font release may be assigned any file name.

• Comments related to new project files

Comment lines in the form of any desired character strings may be added at the time a project file is created. Comments will be printed when the font is printed, and can be modified as needed whenever that Ped/Win is operating.

(3) Pattern files

Font data may be placed in pattern files. Because pattern data is saved in the project file, normally it is only necessary to create a pattern file at the time of font release for the purpose of extracting verification data (writing to mask data specifications) . Pattern files should not be released.

- **Pattern file loading**

Pattern files can be loaded for some OSDC models other than the MB90099.

- **Pattern file output generation**

Do not create more than one pattern file for the same project. This may cause errors . In such cases, the project name should be altered to create another project.

- **Extracting verification data**

Three data points, the first and last addresses and one other random address, should be extracted from pattern file data and written into the mask data specifications. The random address should not include the data values "00" or "FF."

Note : Ped/Win display functions are based on OSDC specifications, however some display specifications may not be identical to actual OSDC specifications. Users should consult specification documents for details.

(Data comparison)

After data release, once ROM mask processing is completed FUJITSU MICROELECTRONICS will extract the ROM data used in this process. Users should verify that the extracted data is identical to the pattern file data that was submitted, and return a written statement of data comparison indicating whether that data is identical or not . If the data is not identical, contact FUJITSU MICROELECTRONICS's sales representative immediately. Data errors may cause errors in ES production.

■ ORDERING INFORMATION

Part Number	Package	Remarks
MB90099PFV	20-pin Plastic SSOP (FPT-20P-M03)	
MB90099LGA	20-pin Plastic FLGA (LGA-20P-M01)	

■ PACKAGE DIMENSION

20-pin Plastic SSOP
(FPT-20P-M03)

* : These dimensions do not include resin protrusion.

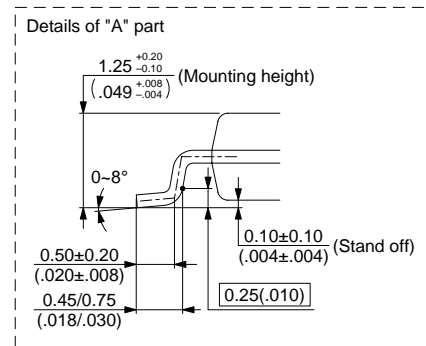
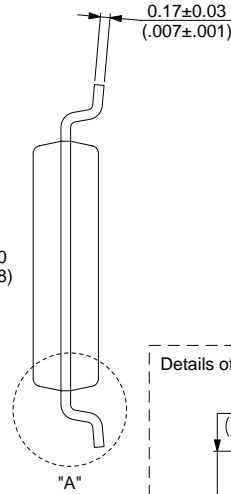
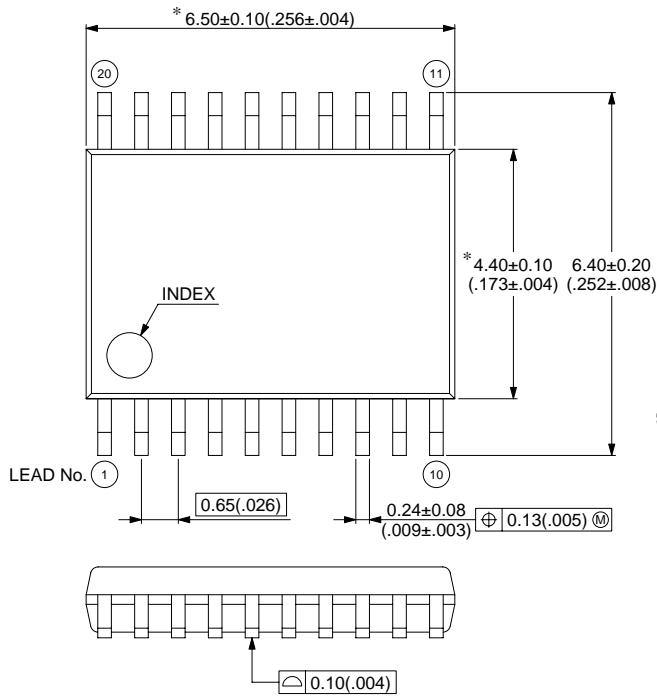

© 1999 FUJITSU LIMITED F20012S-3C-5

Dimensions in mm (inches)

(Continued)

(Continued)

20-pin plastic FLGA (LGA-20P-M02)

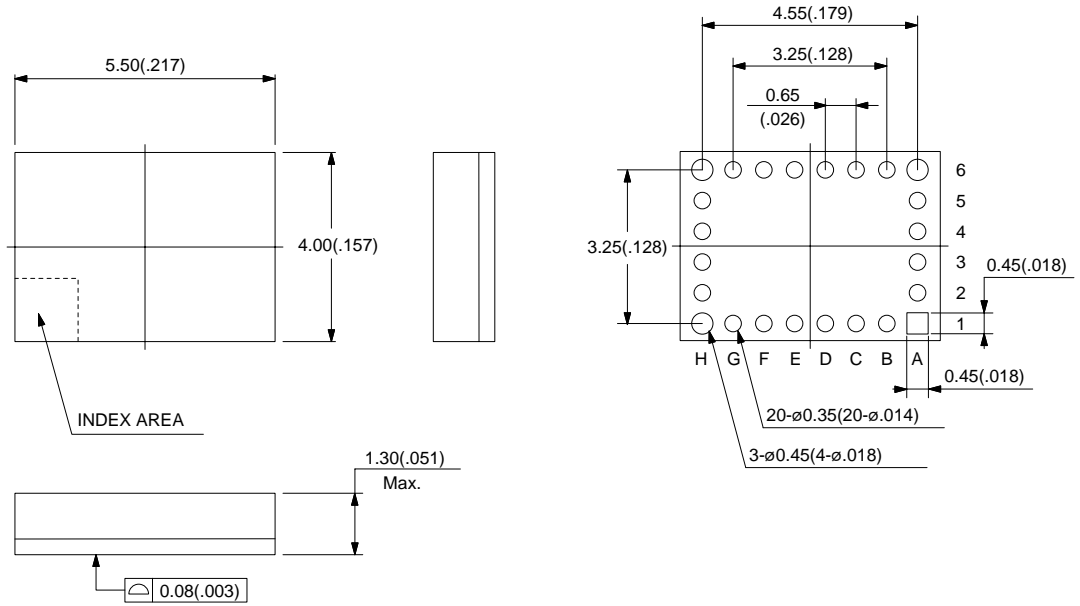

© 2001 FUJITSU LIMITED L20001S-c-1-1

Dimensions in mm (inches)

FUJITSU MICROELECTRONICS LIMITED

Shinjuku Dai-Ichi Seimei Bldg. 7-1, Nishishinjuku 2-chome, Shinjuku-ku,
Tokyo 163-0722, Japan Tel: +81-3-5322-3347 Fax: +81-3-5322-3387
<http://jp.fujitsu.com/fml/en/>

For further information please contact:

North and South America

FUJITSU MICROELECTRONICS AMERICA, INC.
1250 E. Arques Avenue, M/S 333
Sunnyvale, CA 94085-5401, U.S.A.
Tel: +1-408-737-5600 Fax: +1-408-737-5999
<http://www.fma.fujitsu.com/>

Europe

FUJITSU MICROELECTRONICS EUROPE GmbH
Pittlerstrasse 47, 63225 Langen,
Germany
Tel: +49-6103-690-0 Fax: +49-6103-690-122
<http://emea.fujitsu.com/microelectronics/>

Korea

FUJITSU MICROELECTRONICS KOREA LTD.
206 KOSMO TOWER, 1002 Daechi-Dong,
Kangnam-Gu, Seoul 135-280
Korea
Tel: +82-2-3484-7100 Fax: +82-2-3484-7111
<http://www.fmk.fujitsu.com/>

Asia Pacific

FUJITSU MICROELECTRONICS ASIA PTE LTD.
151 Lorong Chuan, #05-08 New Tech Park,
Singapore 556741
Tel: +65-6281-0770 Fax: +65-6281-0220
<http://www.fujitsu.com/sg/services/micro/semiconductor/>

FUJITSU MICROELECTRONICS SHANGHAI CO., LTD.
Rm.3102, Bund Center, No.222 Yan An Road(E),
Shanghai 200002, China
Tel: +86-21-6335-1560 Fax: +86-21-6335-1605
<http://cn.fujitsu.com/fmc/>

FUJITSU MICROELECTRONICS PACIFIC ASIA LTD.
10/F., World Commerce Centre, 11 Canton Road
Tsimshatsui, Kowloon
Hong Kong
Tel: +852-2377-0226 Fax: +852-2376-3269
<http://cn.fujitsu.com/fmc/tw>

All Rights Reserved.

The contents of this document are subject to change without notice.

Customers are advised to consult with sales representatives before ordering.

The information, such as descriptions of function and application circuit examples, in this document are presented solely for the purpose of reference to show examples of operations and uses of FUJITSU MICROELECTRONICS device; FUJITSU MICROELECTRONICS does not warrant proper operation of the device with respect to use based on such information. When you develop equipment incorporating the device based on such information, you must assume any responsibility arising out of such use of the information.

FUJITSU MICROELECTRONICS assumes no liability for any damages whatsoever arising out of the use of the information.

Any information in this document, including descriptions of function and schematic diagrams, shall not be construed as license of the use or exercise of any intellectual property right, such as patent right or copyright, or any other right of FUJITSU MICROELECTRONICS or any third party or does FUJITSU MICROELECTRONICS warrant non-infringement of any third-party's intellectual property right or other right by using such information. FUJITSU MICROELECTRONICS assumes no liability for any infringement of the intellectual property rights or other rights of third parties which would result from the use of information contained herein.

The products described in this document are designed, developed and manufactured as contemplated for general use, including without limitation, ordinary industrial use, general office use, personal use, and household use, but are not designed, developed and manufactured as contemplated (1) for use accompanying fatal risks or dangers that, unless extremely high safety is secured, could have a serious effect to the public, and could lead directly to death, personal injury, severe physical damage or other loss (i.e., nuclear reaction control in nuclear facility, aircraft flight control, air traffic control, mass transport control, medical life support system, missile launch control in weapon system), or (2) for use requiring extremely high reliability (i.e., submersible repeater and artificial satellite).

Please note that FUJITSU MICROELECTRONICS will not be liable against you and/or any third party for any claims or damages arising in connection with above-mentioned uses of the products.

Any semiconductor devices have an inherent chance of failure. You must protect against injury, damage or loss from such failures by incorporating safety design measures into your facility and equipment such as redundancy, fire protection, and prevention of over-current levels and other abnormal operating conditions.

Exportation/release of any products described in this document may require necessary procedures in accordance with the regulations of the Foreign Exchange and Foreign Trade Control Law of Japan and/or US export control laws.

The company names and brand names herein are the trademarks or registered trademarks of their respective owners.