

*ASSP For Power Supply Applications (Lithium ion battery charger)*

# DC/DC Converter IC for Charging

## MB3875/MB3877

### ■ DESCRIPTION

The MB3875 and MB3877 are charging DC/DC converter ICs suitable for down-conversion, which uses pulse width modulation (PWM) for controlling the output voltage and current independently.

These ICs can dynamically control the secondary battery's charge current by detecting a voltage drop in an AC adapter in order to keep its power constant (dynamically-controlled charging).

The charging method enables quick charging, for example, with the AC adapter during operation of a notebook PC.

With an on-chip output voltage setting resistor which allows the output voltage to be set at high precision, these ICs are best suited as internal battery chargers for notebook PCs.

The MB3875 and MB3877 support 3-cell and 4-cell batteries, respectively.

These products are covered by US Patent Number 6,147,477.

### ■ FEATURES

- Detecting a voltage drop in the AC adapter and dynamically controlling the charge current (Dynamically-controlled charging)
- High efficiency : 95 %
- Wide range of operating supply voltages: 7 V to 25 V
- Output voltage precision (Output voltage setting resistor integrated):  $0 \pm 0.8 \%$  ( $T_a = +25 \text{ }^\circ\text{C}$ )

*(Continued)*

### ■ PACKAGE

24-pin plastic SSOP

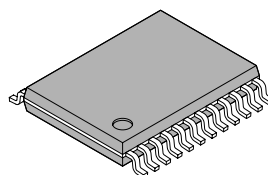

(FPT-24P-M03)

# MB3875/3877

(Continued)

- High precision reference voltage source:  $4.2\text{ V} \pm 0.8\%$
- Support for frequency setting using an external resistor  
(Frequency setting capacitor integrated) :100 kHz to 500 kHz
- On-chip current detector amplifier with wide in-phase input voltage range : 0 V to  $V_{CC}$
- On-chip standby current function: 0  $\mu\text{A}$  (Typ)
- On-chip soft-start function
- Internal totem-pole output stage supporting P-channel MOS FETs devices

## ■ PIN ASSIGNMENT

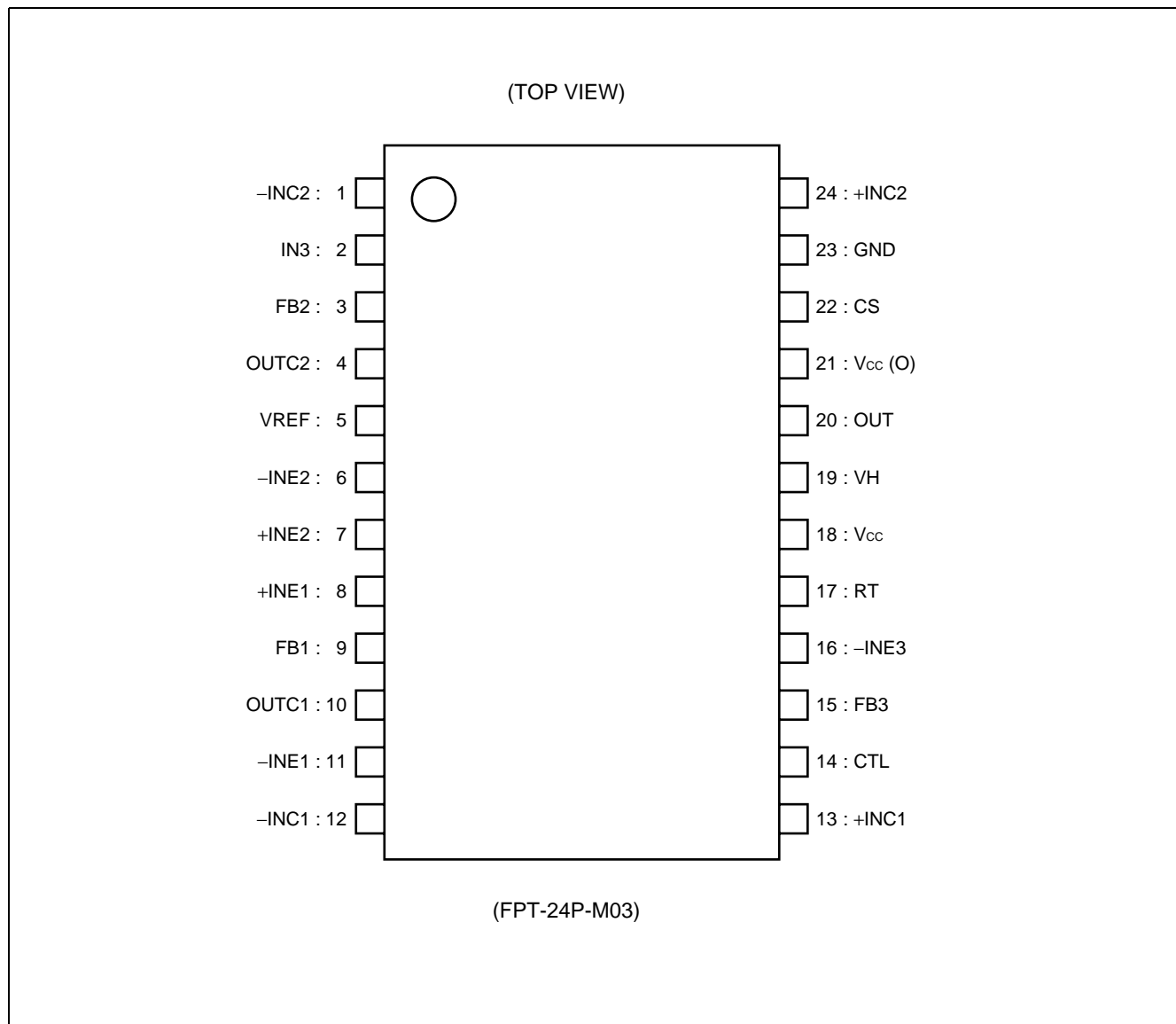

## ■ PIN DESCRIPTION

Pin No.	Symbol	I/O	Descriptions
1	-INC2	I	Current detection amplifier (Current Amp. 2) input pin.
2	IN3	I	DC/DC output voltage (charge voltage) input pin.
3	FB2	O	Error amplifier (Error Amp. 2) output pin.
4	OUTC2	O	Current detection amplifier (Current Amp. 2) output pin.
5	VREF	O	Reference voltage output pin.
6	-INE2	I	Error amplifier (Error Amp. 2) inverted input pin.
7	+INE2	I	Error amplifier (Error Amp. 2) non-inverted input pin.
8	+INE1	I	Error amplifier (Error Amp. 1) non-inverted input pin
9	FB1	O	Error amplifier (Error Amp. 1) output pin.
10	OUTC1	O	Current detection amplifier (Current Amp. 1) output pin.
11	-INE1	I	Error amplifier (Error Amp. 1) inverted input pin.
12	-INC1	I	Current detection amplifier (Current Amp. 1) input pin.
13	+INC1	I	Current detection amplifier (Current Amp. 1) input pin.
14	CTL	I	Power supply control pin. Setting the CTL pin low places the IC in the standby mode.
15	FB3	O	Error amplifier (Error Amp. 3) output pin.
16	-INE3	I	Error amplifier (Error Amp. 3) inverted input pin.
17	RT	—	Triangular-wave oscillation frequency setting resistor connection pin.
18	V <sub>CC</sub>	—	Power supply pin for reference power supply and control circuit.
19	V <sub>H</sub>	O	Power supply pin for FET drive circuit (V <sub>H</sub> = V <sub>CC</sub> - 5 V).
20	OUT	O	High-side FET gate drive pin.
21	V <sub>CC</sub> (O)	—	Output circuit power supply.
22	CS	—	Soft-start capacitor connection pin.
23	GND	—	Ground pin.
24	+INC2	I	Current detection amplifier (Current Amp. 2) input pin.

# MB3875/3877

## ■ BLOCK DIAGRAM

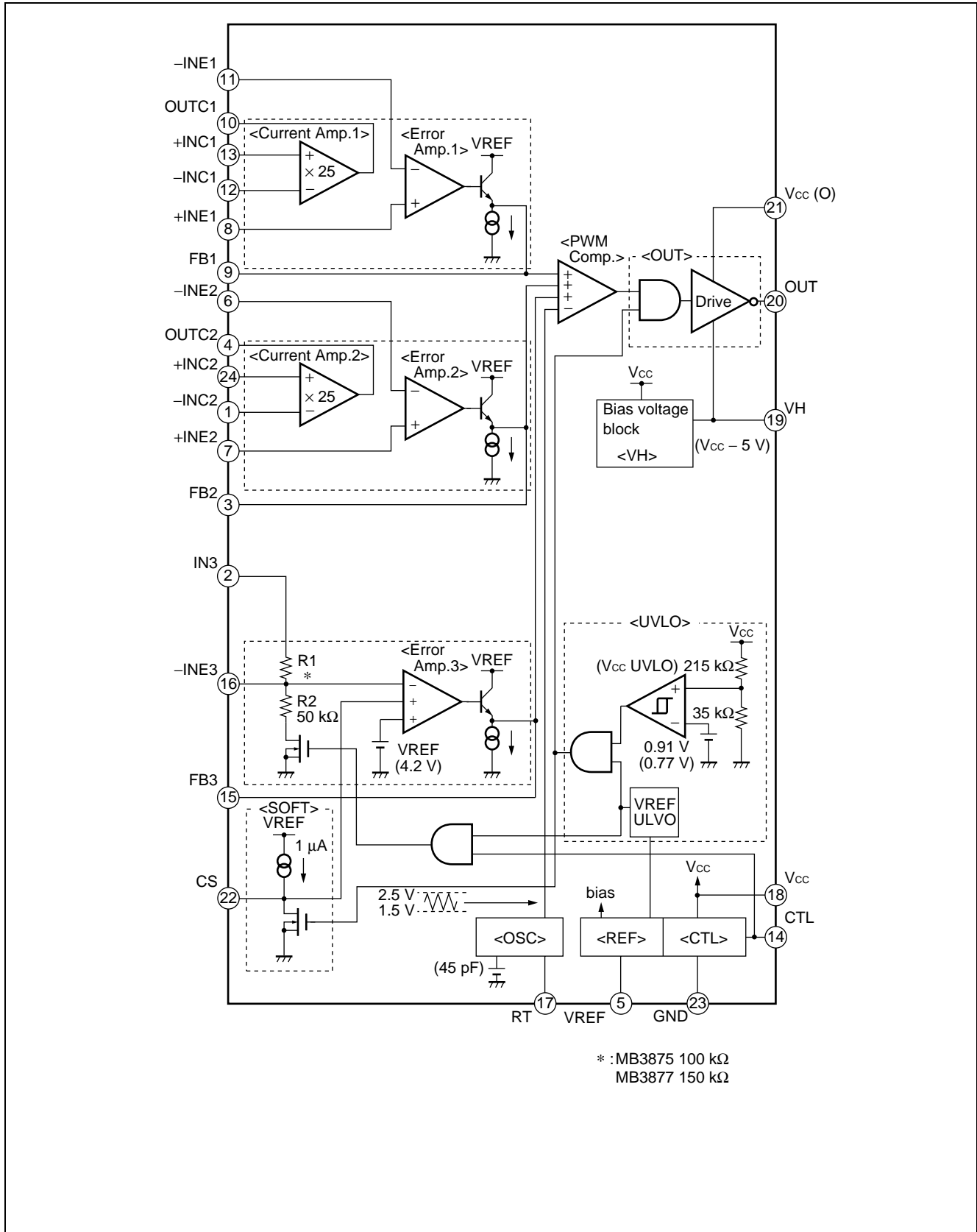

## ■ ABSOLUTE MAXIMUM RATINGS

Parameter	Symbol	Conditions	Rating		Unit
			Min	Max	
Power supply voltage	V <sub>CC</sub>	V <sub>CC</sub> , V <sub>CC(O)</sub>	—	28	V
Output current	I <sub>OUT</sub>	—	—	60	mA
Peak output current	I <sub>OUT</sub>	Duty ≤ 5% (t = 1 / f <sub>OSC</sub> × Duty)	—	500	mA
Power dissipation	P <sub>D</sub>	T <sub>a</sub> ≤ +25°C	—	740*	mW
Storage temperature	T <sub>stg</sub>	—	-55	+125	°C

\*: The package is mounted on the dual-sided epoxy board (10 cm × 10 cm).

WARNING: Semiconductor devices can be permanently damaged by application of stress (voltage, current, temperature, etc.) in excess of absolute maximum ratings. Do not exceed these ratings.

## ■ RECOMMENDED OPERATING CONDITIONS

Parameter	Symbol	Conditions	Value			Unit
			Min	Typ	Max	
Power supply voltage	V <sub>CC</sub>	V <sub>CC</sub> , V <sub>CC(O)</sub>	7	—	25	V
Reference voltage output current	I <sub>REF</sub>	—	-1	—	0	mA
VH pin output current	I <sub>VH</sub>	—	0	—	30	mA
Input voltage	V <sub>IN</sub>	IN3	0	—	17	V
	V <sub>INE</sub>	-INE1, -INE2, +INE1, +INE2	0	—	V <sub>CC</sub> - 1.8	V
	V <sub>INC</sub>	+INC1, +INC2, -INC1, -INC2,	0	—	V <sub>CC</sub>	V
CTL pin input voltage	V <sub>CTL</sub>	—	0	—	25	V
Output current	I <sub>OUT</sub>	—	-45	—	45	mA
Peak output current	I <sub>OUT</sub>	Duty ≤ 5% (t = 1 / f <sub>OSC</sub> × Duty)	-450	—	450	mA
Oscillator frequency	f <sub>OSC</sub>	—	100	290	500	kHz
Timing resistor	R <sub>T</sub>	—	33	47	130	kΩ
Soft-start capacitor	C <sub>S</sub>	—	—	2200	100000	pF
VH pin capacitor	C <sub>VH</sub>	—	—	0.1	1.0	μF
Reference voltage output capacitor	C <sub>REF</sub>	—	—	0.1	1.0	μF
Operating temperature	T <sub>a</sub>	—	-30	+25	+85	°C

WARNING: The recommended operating conditions are required in order to ensure the normal operation of the semiconductor device. All of the device's electrical characteristics are warranted when the device is operated within these ranges.

Always use semiconductor devices within their recommended operating condition ranges. Operation outside these ranges may adversely affect reliability and could result in device failure.

No warranty is made with respect to uses, operating conditions, or combinations not represented on the data sheet. Users considering application outside the listed conditions are advised to contact their representatives beforehand.

# MB3875/3877

## ■ ELECTRICAL CHARACTERISTICS

(MB3875: Ta = +25°C, V<sub>CC</sub> = 16 V, V<sub>CC</sub>(O) = 16 V, V<sub>REF</sub> = 0 mA)

(MB3877: Ta = +25°C, V<sub>CC</sub> = 19 V, V<sub>CC</sub>(O) = 19 V, V<sub>REF</sub> = 0 mA)

Parameter	Symbol	Pin No.	Conditions	Value			Unit	Remarks	
				Min	Typ	Max			
Reference voltage block (Ref)	Output voltage	V <sub>REF</sub>	5	Ta = +25°C	4.167	4.200	4.233	V	
				Ta = -30°C to +85°C	4.158	4.200	4.242	V	
	Input stability	Line	5	V <sub>CC</sub> = 7 V to 25 V	—	3	10	mV	
	Load stability	Load	5	V <sub>REF</sub> = 0 mA to -1 mA	—	1	10	mV	
	Short-circuit output current	I <sub>OS</sub>	5	V <sub>REF</sub> = 1 V	-25	-15	-5	mA	
Under voltage lockout protection circuit block (UVLO)	Threshold voltage	V <sub>TLH</sub>	18	V <sub>CC</sub> = V <sub>CC</sub> (O), V <sub>CC</sub> =	6.3	6.6	6.9	V	
		V <sub>THL</sub>		V <sub>CC</sub> = V <sub>CC</sub> (O), V <sub>CC</sub> =	5.3	5.6	5.9	V	
	Hysteresis width	V <sub>H</sub>	18	V <sub>CC</sub> = V <sub>CC</sub> (O)	0.7	1.0	1.3	V	
	Threshold voltage	V <sub>TLH</sub>	5	V <sub>REF</sub> =	2.6	2.8	3.0	V	
		V <sub>THL</sub>		V <sub>REF</sub> =	2.4	2.6	2.8	V	
	Hysteresis width	V <sub>H</sub>	5	—	0.05	0.20	0.35	V	
Soft-start block (SOFT)	Charge current	I <sub>CS</sub>	22	—	-1.3	-0.8	-0.5	μA	
Triangular waveform oscillator circuit block (OSC)	Oscillation frequency	f <sub>OSC</sub>	20	RT = 47 kΩ	260	290	320	kHz	
	Frequency temperature stability	Δf/f <sub>dT</sub>	20	Ta = -30°C to +85°C	—	1*	—	%	

\*: Standard design value.

(Continued)

(MB3875:  $T_a = +25^\circ\text{C}$ ,  $V_{CC} = 16\text{ V}$ ,  $V_{CC(O)} = 16\text{ V}$ ,  $V_{REF} = 0\text{ mA}$ )

(MB3877:  $T_a = +25^\circ\text{C}$ ,  $V_{CC} = 19\text{ V}$ ,  $V_{CC(O)} = 19\text{ V}$ ,  $V_{REF} = 0\text{ mA}$ )

Parameter	Symbol	Pin No	Conditions	Value			Unit	Remarks	
				Min	Typ	Max			
Error amplifier block (Error Amp.1, 2)	Input offset voltage	$V_{IO}$	6,7,8,11	FB1 = FB2 = 2 V	—	1	5	mV	
	Input bias current	$I_B$	6,7,8,11	—	-100	-30	—	nA	
	Common mode input voltage range	$V_{CM}$	6,7,8,11	—	0	—	$V_{CC}-1.8$	V	
	Voltage gain	$A_V$	3,9	DC	—	100*	—	dB	
	Frequency bandwidth	BW	3,9	$A_V = 0\text{ dB}$	—	2.0*	—	MHz	
	Output voltage	$V_{FBH}$	3,9	—	3.9	4.1	—	V	
		$V_{FBL}$	3,9	—	—	20	200	mV	
	Output source current	$I_{SOURCE}$	3,9	FB1 = FB2 = 2 V	—	-2.0	-0.6	mA	
Output sink current	$I_{SINK}$	3,9	FB1 = FB2 = 2 V	150	300	—	$\mu\text{A}$		
Error amplifier block (Error Amp.3)	Threshold voltage	$V_{TH}$	2	FB3 = 2 V, $T_a = +25^\circ\text{C}$	12.500	12.600	12.700	V	MB3875
					16.666	16.800	16.934	V	MB3877
				FB3 = 2 V, $T_a = -30^\circ\text{C to } +85^\circ\text{C}$	12.474	12.600	12.726	V	MB3875
					16.632	16.800	16.968	V	MB3877
	Input current	$I_{INE3H}$	2	IN3 = 12.6 V	—	84	150	$\mu\text{A}$	MB3875
				IN3 = 16.8 V	—	84	150	$\mu\text{A}$	MB3877
		$I_{INE3L}$	2	$V_{CC} = 0\text{ V}$ , IN3 = 12.6 V	—	0	1	$\mu\text{A}$	MB3875
				$V_{CC} = 0\text{ V}$ , IN3 = 16.8 V	—	0	1	$\mu\text{A}$	MB3877
	Input resistor	$R_1$	2	—	70	100	130	$\text{k}\Omega$	MB3875
					105	150	195	$\text{k}\Omega$	MB3877
	$R_2$	16	—	35	50	65	$\text{k}\Omega$		
	Voltage gain	$A_V$	15	DC	—	100*	—	dB	
	Frequency bandwidth	BW	15	$A_V = 0\text{ dB}$	—	2.0*	—	MHz	
	Output voltage	$V_{FBH}$	15	—	3.9	4.1	—	V	
$V_{FBL}$		15	—	—	20	200	mV		
Output source current	$I_{SOURCE}$	15	FB3 = 2 V	—	-2.0	-0.6	mA		
Output sink current	$I_{SINK}$	15	FB3 = 2 V	150	300	—	$\mu\text{A}$		

\*: Standard design value.

(Continued)

# MB3875/3877

(MB3875: Ta = +25°C, V<sub>CC</sub> = 16 V, V<sub>CC</sub>(O) = 16 V, V<sub>REF</sub> = 0 mA)

(MB3877: Ta = +25°C, V<sub>CC</sub> = 19 V, V<sub>CC</sub>(O) = 19 V, V<sub>REF</sub> = 0 mA)

Parameter	Symbol	Pin No.	Conditions	Value			Unit	Remarks	
				Min	Typ	Max			
Current detection amplifier block (Current Amp. 1,2)	I <sub>+INCH</sub>	13, 24	+INC1 = +INC2 = 12.7 V -INC1 = -INC2 = 12.6 V	—	10	20	μA	MB3875	
			+INC1 = +INC2 = 16.9 V -INC1 = -INC2 = 16.8 V	—	10	20	μA	MB3877	
	I <sub>-INCH</sub>	1, 12	+INC1 = +INC2 = 12.7 V -INC1 = -INC2 = 12.6 V	—	0.1	0.2	μA	MB3875	
			+INC1 = +INC2 = 16.9 V -INC1 = -INC2 = 16.8 V	—	0.1	0.2	μA	MB3877	
	I <sub>+INCL</sub>	13, 24	+INC1 = +INC2 = 0.1 V -INC1 = -INC2 = 0 V	-130	-65	—	μA		
	I <sub>-INCL</sub>	1, 12	+INC1 = +INC2 = 0.1V -INC1 = -INC2 = 0 V	-140	-70	—	μA		
	Current detection voltage	V <sub>OUTC1</sub>	4, 10	+INC1 = +INC2 = 12.7 V -INC1 = -INC2 = 12.6 V	2.25	2.5	2.75	V	MB3875
				+INC1 = +INC2 = 16.9 V -INC1 = -INC2 = 16.8 V	2.25	2.5	2.75	V	MB3877
		V <sub>OUTC2</sub>	4, 10	+INC1 = +INC2 = 12.63V -INC1 = -INC2 = 12.6 V	0.50	0.75	1.00	V	MB3875
				+INC1 = +INC2 = 16.83V -INC1 = -INC2 = 16.8 V	0.50	0.75	1.00	V	MB3877
V <sub>OUTC3</sub>		4, 10	+INC1 = +INC2 = 0.1 V -INC1 = -INC2 = 0 V	1.25	2.50	3.75	V		
V <sub>OUTC4</sub>		4, 10	+INC1 = +INC2 = 0.03 V -INC1 = -INC2 = 0 V	0.125	0.750	1.375	V		
Common mode input voltage range	V <sub>CM</sub>	1, 12, 13, 24	—	0	—	V <sub>CC</sub>	V		
Voltage gain	A <sub>v</sub>	4, 10	+INC1 = +INC2 = 12.7 V -INC1 = -INC2 = 12.6 V	22.5	25	27.5	V/V	MB3875	
			+INC1 = +INC2 = 16.9 V -INC1 = -INC2 = 16.8 V	22.5	25	27.5	V/V	MB3877	
Frequency bandwidth	BW	4, 10	A <sub>v</sub> = 0 dB	—	2.0*	—	MHz		
Output voltage	V <sub>OUTCH</sub>	4, 10	—	3.9	4.1	—	V		
	V <sub>OUTCL</sub>	4, 10	—	—	20	200	mV		
Output source current	I <sub>SOURCE</sub>	4, 10	OUTC1 = OUTC2 = 2 V	—	-2.0	-0.6	mA		
Output sink current	I <sub>SINK</sub>	4, 10	OUTC1 = OUTC2 = 2 V	150	300	—	μA		

\*: Standard design value.

(Continued)

(Continued)

(MB3875 : Ta = +25°C, V<sub>CC</sub> = 16 V, V<sub>CC</sub>(O) = 16 V, V<sub>REF</sub> = 0mA)

(MB3877 : Ta = +25°C, V<sub>CC</sub> = 19 V, V<sub>CC</sub>(O) = 19 V, V<sub>REF</sub> = 0mA)

Parameter		Symbol	Pin No.	Conditions	Value			Unit	Remarks
					Min	Typ	Max		
PWM comparator block (PWM Comp.)	Threshold voltage	V <sub>TL</sub>	3,9,15	Duty cycle = 0 %	1.4	1.5	—	V	
		V <sub>TH</sub>	3,9,15	Duty cycle = 100 %	—	2.5	2.6	V	
Output block (OUT)	Output source current	I <sub>SOURCE</sub>	20	OUT = 11 V Duty ≤ 5 % (t = 1/fosc × Duty)	—	-200*	—	mA	MB3875
				OUT = 14 V Duty ≤ 5 % (t = 1/fosc × Duty)	—	-200*	—	mA	MB3877
	Output sink current	I <sub>SINK</sub>	20	OUT = 16 V Duty ≤ 5 % (t = 1/fosc × Duty)	—	200*	—	mA	MB3875
				OUT = 19 V Duty ≤ 5 % (t = 1/fosc × Duty)	—	200*	—	mA	MB3877
	Output ON resistor	R <sub>OH</sub>	20	OUT = -45 mA	—	8.0	16	Ω	
		R <sub>OL</sub>	20	OUT = 45 mA	—	6.5	13	Ω	
	Rise time	tr1	20	OUT = 3300 pF (Equivalent to Si4435DY)	—	70*	—	ns	
	Fall time	tf2	20	OUT = 3300 pF (Equivalent to Si4435DY)	—	60*	—	ns	
Control block (CTL)	CTL input voltage	V <sub>ON</sub>	14	Active mode	2	—	25	V	
		V <sub>OFF</sub>	14	Standby mode	0	—	0.8	V	
	Input current	I <sub>CTLH</sub>	14	CTL = 5 V	—	100	200	μA	
		I <sub>CTL</sub>	14	CTL = 0 V	—	0	1	μA	
Bias voltage block (VH)	Output voltage	VH	19	V <sub>CC</sub> = V <sub>CC</sub> (O) = 7 V to 25 V, VH = 0 to 30 mA	V <sub>CC</sub> -5.5	V <sub>CC</sub> -5.0	V <sub>CC</sub> -4.5	V	
General	Standby current	I <sub>CCS</sub>	18	V <sub>CC</sub> = V <sub>CC</sub> (O), CTL = 0 V	—	0	10	μA	
	Power supply current	I <sub>CC</sub>	18	V <sub>CC</sub> = V <sub>CC</sub> (O), CTL = 5 V	—	6.0	9.0	mA	MB3875
					—	6.5	9.5	mA	MB3877

\*: Standard design value.

## ■ TYPICAL CHARACTERISTICS

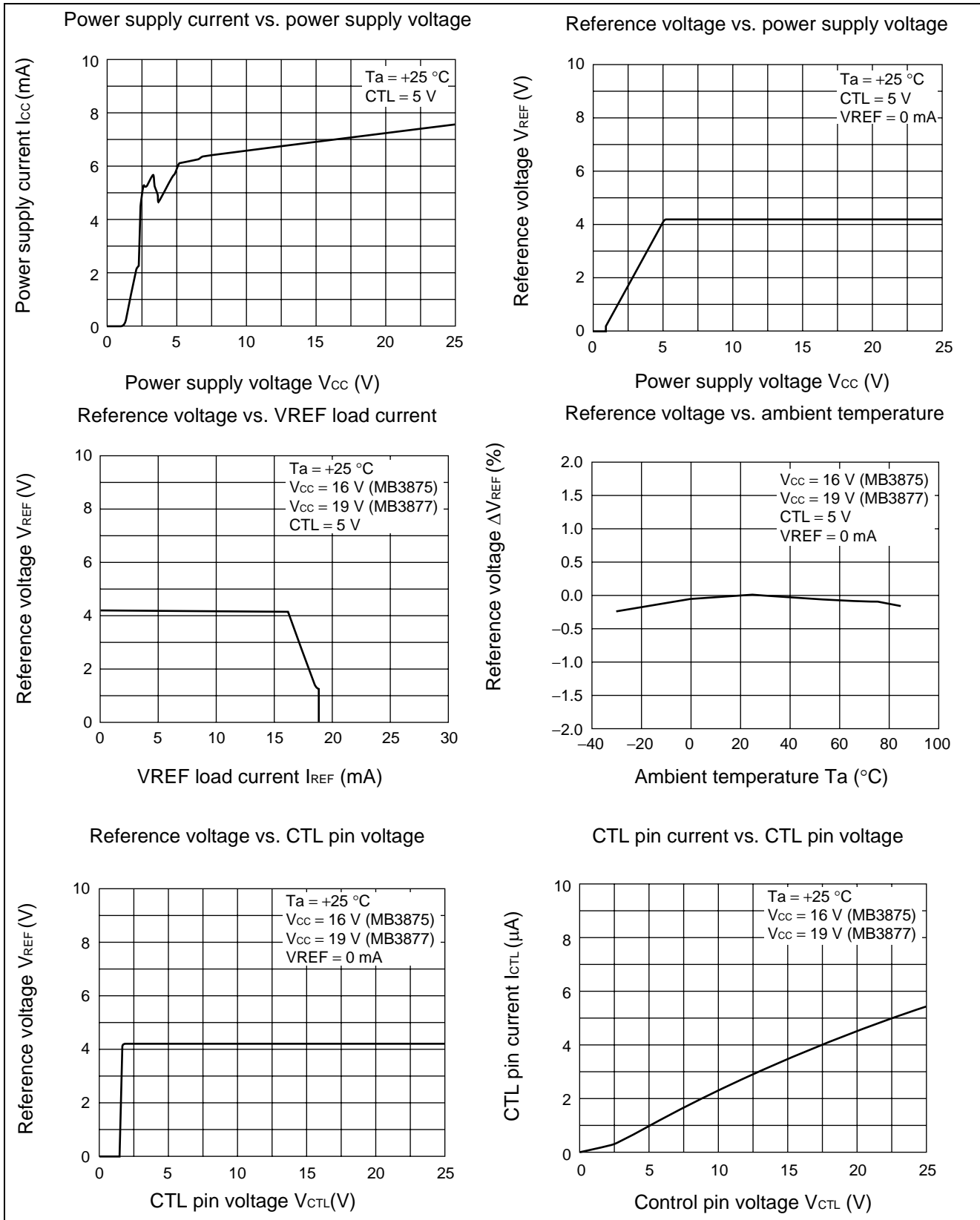

(Continued)

(Continued)

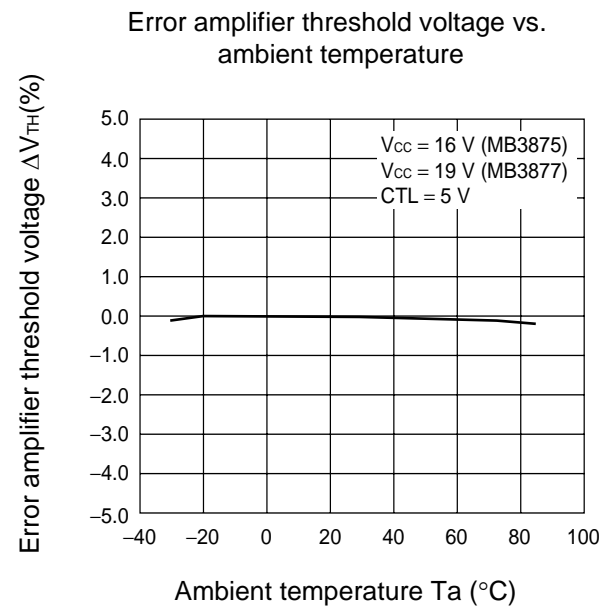
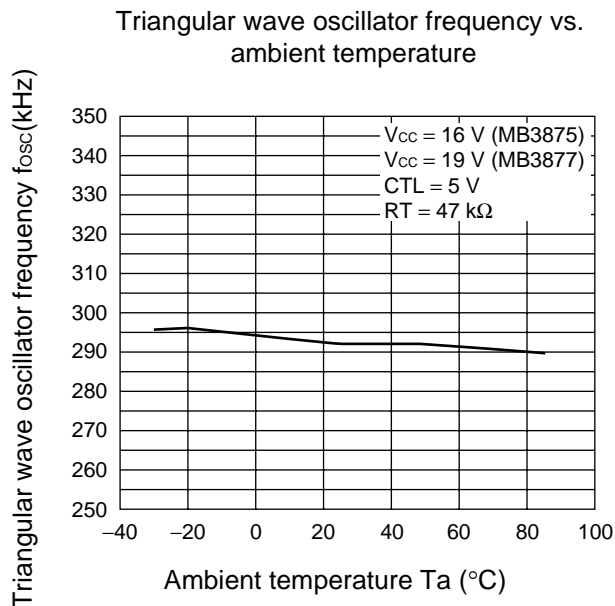
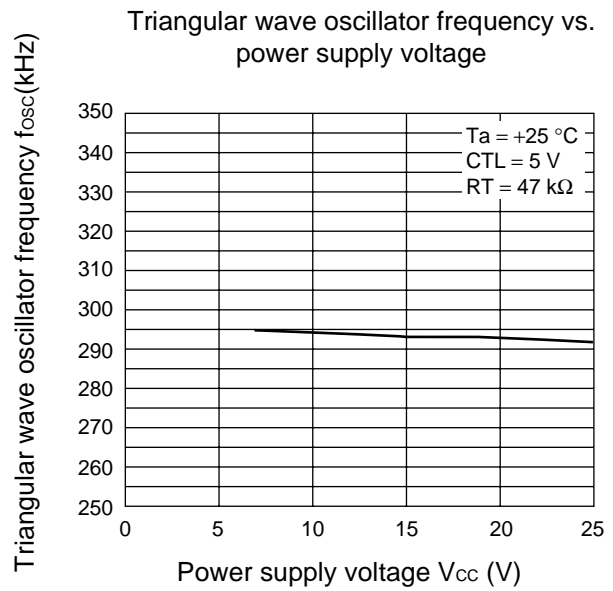
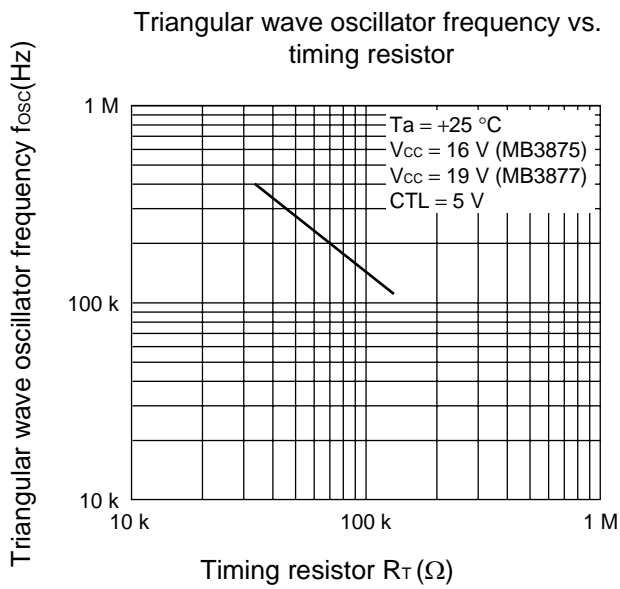

(Continued)

Error amplifier gain and phase vs. frequency

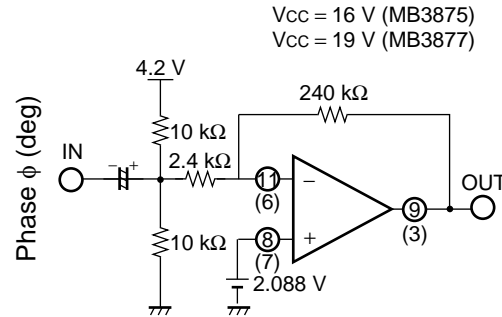
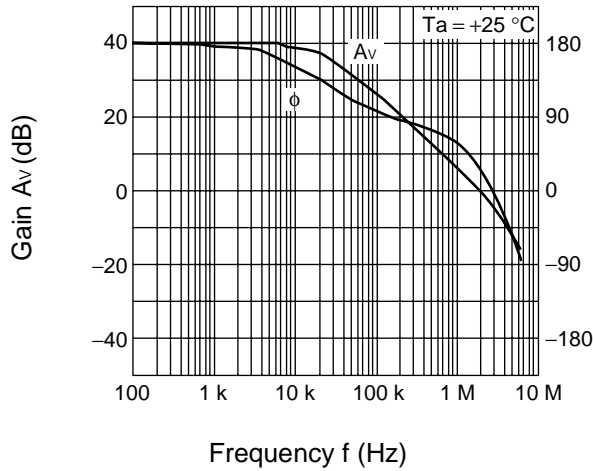

Current detection amplifier gain and phase vs. frequency

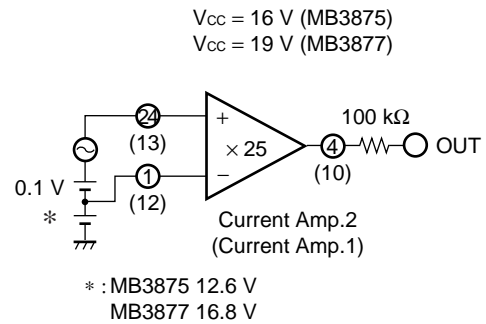
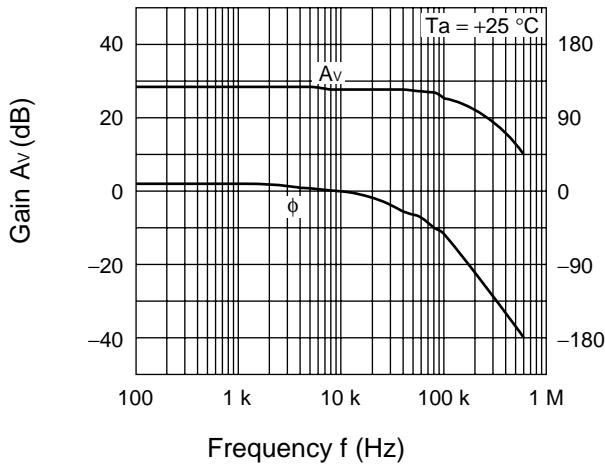

Power dissipation vs. ambient temperature

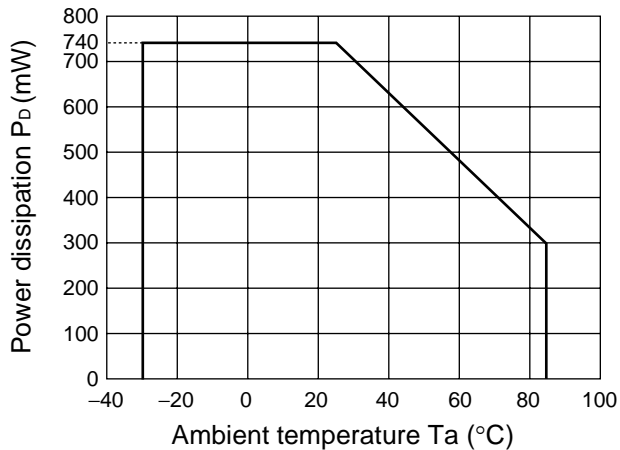

**■ FUNCTIONAL DESCRIPTION****1. DC/DC Converter Unit****(1) Reference voltage block (Ref)**

The reference voltage generator uses the voltage supplied from the Vcc terminal (pin 18) to generate a temperature-compensated, stable voltage ( $\approx 4.2$  V) used as the reference supply voltage for the IC's internal circuitry.

The reference voltage can be output, up to 1 mA, to an external device through the VREF terminal (pin 5).

**(2) Triangular wave oscillator block(OSC)**

The triangular wave oscillator generates a triangular waveform with a frequency setting resistor connected to the internal frequency setting capacitor via the RT terminal (pin 17).

The triangular wave is input to the PWM comparator on the IC.

**(3) Error amplifier block (Error Amp. 1)**

This error amplifier (Error Amp. 1) detects a voltage drop in the AC adapter and outputs a PWM control signal.

In addition, an arbitrary loop gain can be set by connecting a feedback resistor and capacitor from the FB1 terminal (pin 9) to the -INE1 terminal (pin 11) of the error amplifier, enabling stable phase compensation to the system.

**(4) Error amplifier block (Error Amp. 2)**

This error amplifier (Error Amp. 2) detects the output signal from the current detector amplifier (Current Amp. 2), compares it with the +INE2 terminal (pin 7), and outputs a PWM control signal to control the charge current.

In addition, an arbitrary loop gain can be set by connecting a feedback resistor and capacitor from the FB2 terminal (pin 3) to the -INE2 terminal (pin 6) of the error amplifier, enabling stable phase compensation to the system.

**(5) Error amplifier block (Error Amp. 3)**

This error amplifier (Error Amp. 3) detects the output voltage from the DC/DC converter and outputs the PWM control signal. The error amplifier inverting input pin is connected to the output voltage setting resistor in the IC, eliminating the need for an external resistor for setting the output voltage. The MB3875 and MB3877 are set to output voltage of 12.6 V (for a 3-cell battery) and 16.8 V (for a 4-cell battery), respectively; these ICs are suitable for use in equipment that uses a lithium-ion battery.

In addition, an arbitrary loop gain can be set by connecting a feedback resistor and capacitor from the FB3 terminal (pin 15) to the -INE3 terminal (pin 16) of the error amplifier, enabling stable phase compensation to the system.

Connecting a soft-start capacitor to the CS terminal (pin 22) prevents surge currents when the IC is turned on. Using an error amplifier for soft-start detection makes the soft-start time constant, independent of the output load.

**(6) Current detector amplifier block (Current Amp. 2)**

The current detection amplifier (Current Amp. 2) detects a voltage drop which occurs between both ends of the output sense resistor (RS) due to the flow of the charge current, using the +INC2 terminal (pin 24) and -INC2 terminal (pin 1). Then it outputs the signal amplified by 25 times to the error amplifier (Error Amp. 2) at the next stage.

## (7) PWM comparator block (PWM Comp.)

The PWM comparator circuit is a voltage-pulse width converter for controlling the output duty of the error amplifiers (Error Amp. 1 to Error Amp. 3) depending on their output voltage.

The PWM comparator circuit compares the triangular wave generated by the triangular wave oscillator to the error amplifier output voltage and turns on the external output transistor during the interval in which the triangular wave voltage is lower than the error amplifier output voltage.

## (8) Output block (OUT)

The output circuit uses a totem-pole configuration capable of driving an external P-channel MOS FET.

The output “L” level sets the output amplitude to 5 V (typical) using the voltage generated by the bias voltage block (VH).

This results in increasing conversion efficiency and suppressing the withstand voltage of the connected external transistor in a wide range of input voltages.

## (9) Control block (CTL)

Setting the CTL terminal (pin 14) low places the IC in the standby mode. (The supply current is 10  $\mu$ A at maximum in the standby mode.)

## (10) Bias voltage block (VH)

The bias voltage circuit outputs  $V_{cc} - 5$  V (typical) as the minimum potential of the output circuit. In the standby mode, this circuit outputs the potential equal to  $V_{cc}$ .

## 2. Protection Functions

### Low-V<sub>cc</sub> malfunction preventive circuit (UVLO)

The transient state or a momentary decrease in supply voltage or internal reference voltage (VREF), which occurs when the power supply is turned on, may cause malfunctions in the control IC, resulting in breakdown or degradation of the system. To prevent such malfunction, the low-V<sub>cc</sub> malfunction preventive circuit detects a supply voltage or internal reference voltage drop and fixes the OUT terminal (pin 20) to the “H” level. The system restores voltage supply when the supply voltage or internal reference voltage reaches the threshold voltage of the low-V<sub>cc</sub> malfunction preventive circuit.

## 3. Soft-Start Function

### Soft-start block (SOFT)

Connecting a capacitor to the CS terminal (pin 22) prevents surge currents when the IC is turned on. Using an error amplifier for soft-start detection makes the soft-start time constant, independent of the output load of the DC/DC converter.

## ■ METHOD OF SETTING THE CHARGING CURRENT

The charge current (output control current) value can be set with the voltage at the +INE2 terminal.

If a current exceeding the set value attempts to flow, the charge voltage drops according to the set current value.

Battery charge current setting voltage

$$+INE2 (V) = 25 \times I1 (A) \times R_s (\Omega)$$

## ■ METHOD OF SETTING THE SOFT-START TIME

Upon activation, the IC starts charging the capacitor (Cs) connected to the CS terminal (pin 22).

The error amplifier causes soft-start operation to be performed with the output voltage in proportion to the CS pin voltage regardless of the load current of the DC/DC converter.

Soft-start time ts (Time taken for the output voltage to reach 100 %)

$$t_s (s) \approx 4.2 \times C_s (\mu F)$$

## ■ METHOD OF SETTING THE TRIANGULAR WAVE OSCILLATOR FREQUENCY SETTING

The triangular wave oscillator frequency can be set by the timing resistor (R<sub>T</sub>) connected the RT terminal (pin 17).

Triangular wave oscillator frequency f<sub>osc</sub>

$$f_{osc} (kHz) \approx 14444 / R_T (k\Omega)$$

## ■ AC ADAPTER VOLTAGE DETECTION

With an external resistor connected to the +INE1 terminal, the IC enters the dynamically-controlled charging mode to reduce the charge current to keep AC adapter power constant when the partial potential point A of the AC adapter voltage (Vcc) becomes lower than the voltage at the -INE1 terminal.

AC adapter detected voltage setting Vth

$$V_{th} (V) = (R1 + R2) / R2 \times -INE1$$

- INE1 setting voltage range : 1.176 V to 4.2 V (equivalent to 7 V to 25 V for Vcc)

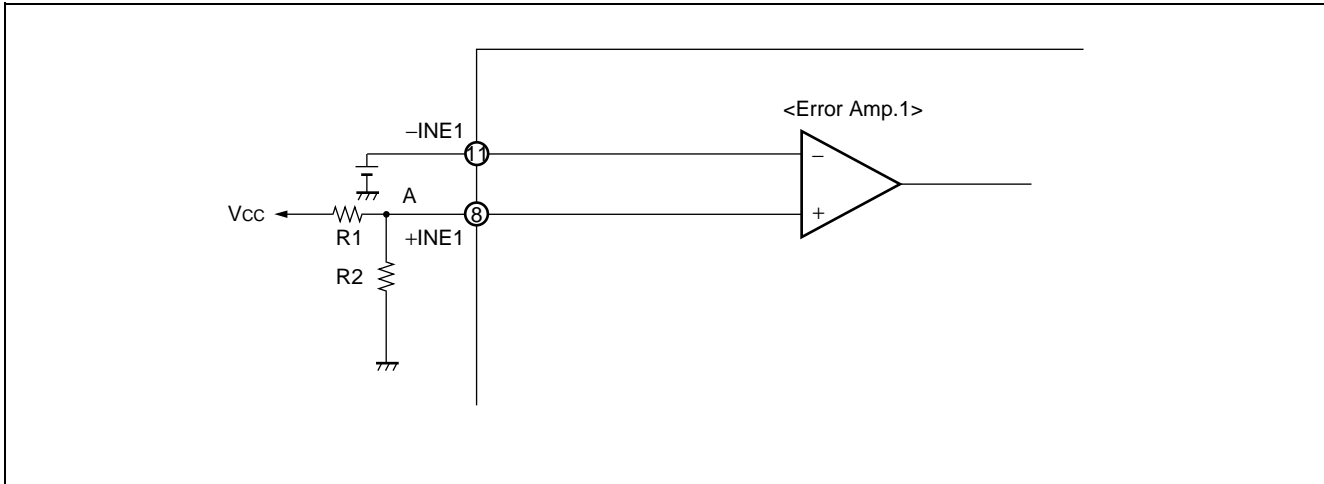

## ■ OPERATION TIMING DIAGRAM

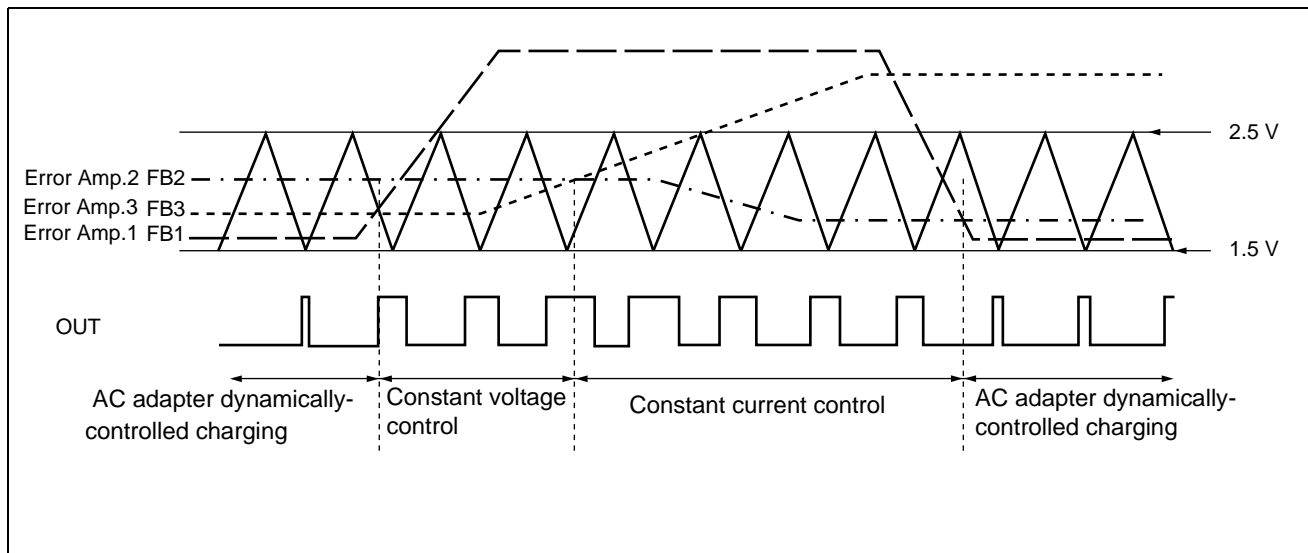

## ■ NOTE ON AN EXTERNAL REVERSE-CURRENT PREVENTIVE DIODE

Insert a reverse-current preventive diode (D) at one of the three locations marked \* to prevent reverse current from the battery.

Pay attention to the voltage/current characteristics of the reverse-current preventive diode (D) not to let it exceed the overcharge stop voltage.

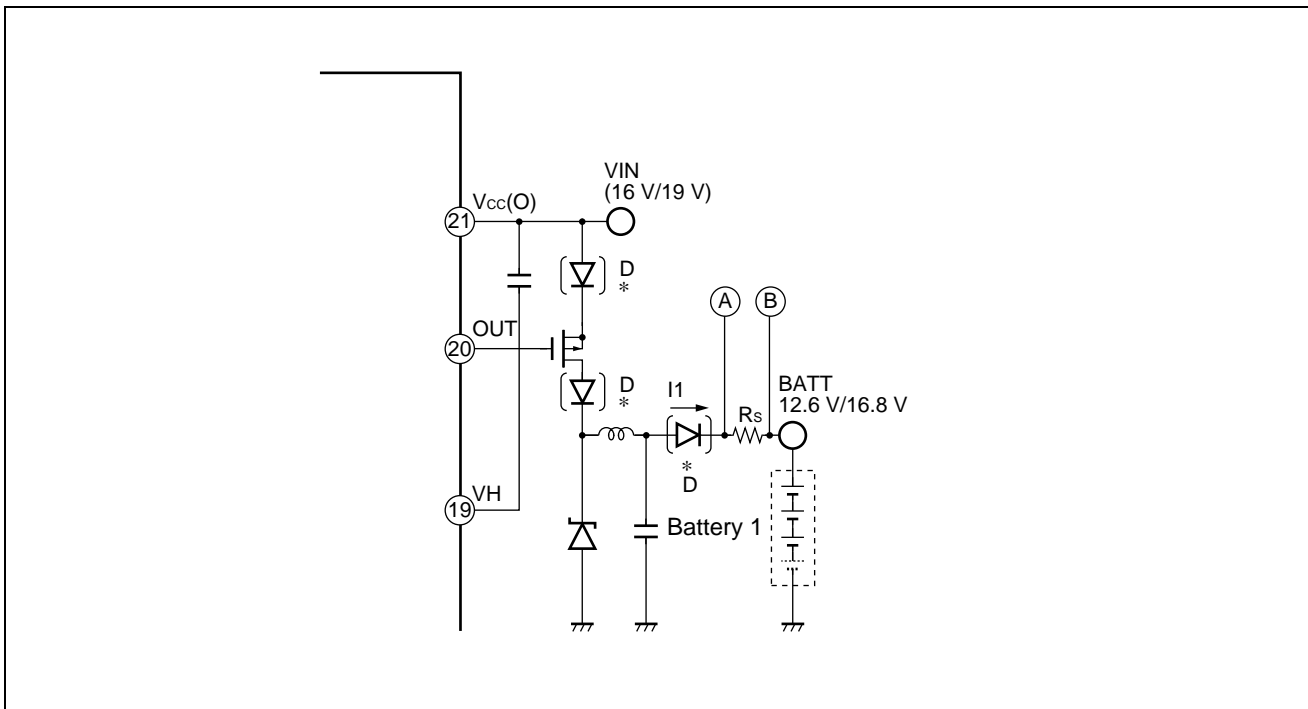

# MB3875/3877

## APPLICATION EXAMPLE

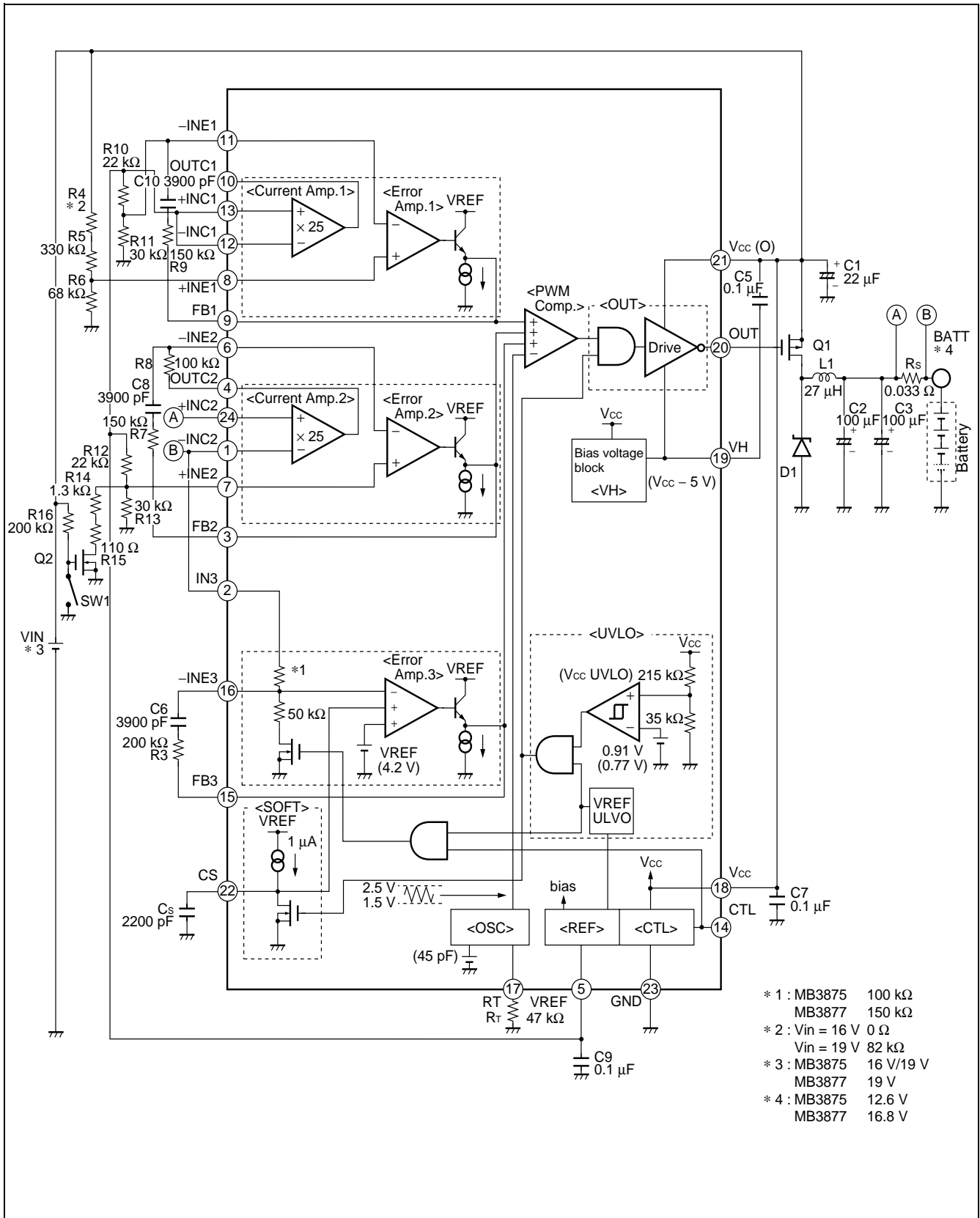

## ■ PARTS LIST

COMPONENT	ITEM	SPECIFICATION		VENDOR	PARTS NO.
Q1	FET	Si4435DY		VISHAY SILICONIX	Si4435DY
Q2	FET	2N7002		VISHAY SILICONIX	2N7002
D1	Diode	MBRS130LT3		MOTOROLA	MBRS130LT3
L1	Coil	27 $\mu$ H	3.4A, 34m $\Omega$	SUMIDA	CDRH127-27 $\mu$ H
C1	OS Condensor	22 $\mu$ F	25V(10%)	—	—
C2	OS Condensor	100 $\mu$ F	16V(10%)		
C3	OS Condensor	100 $\mu$ F	25V(10%) 16V(10%) 25V(10%)		
Cs	Ceramics Condensor	2200pF	10%		
C5	Ceramics Condensor	0.1 $\mu$ F	16V		
C6	Ceramics Condensor	3900pF	10%		
C7	Ceramics Condensor	0.1pF	25V		
C8	Ceramics Condensor	3900pF	10%		
C9	Ceramics Condensor	0.1 $\mu$ F	16V		
C10	Ceramics Condensor	3900pF	10%		
Rs	Resistor	0.033 $\Omega$	1.0%	—	—
R <sub>T</sub>	Resistor	47k $\Omega$	1.0%		
R3	Resistor	200k $\Omega$	1.0%		
R4	Resistor	0 $\Omega$	Jumper line		
		82k $\Omega$	0.5%		
R5	Resistor	330k $\Omega$	0.5%		
R6	Resistor	68k $\Omega$	0.5%		
R7	Resistor	150k $\Omega$	1.0%		
R8	Resistor	100k $\Omega$	1.0%		
R9	Resistor	150k $\Omega$	1.0%		
R10	Resistor	22k $\Omega$	0.5%		
R11	Resistor	30k $\Omega$	0.5%		
R12	Resistor	22k $\Omega$	0.5%		
R13	Resistor	30k $\Omega$	0.5%		
R14	Resistor	1.3k $\Omega$	0.5%		
R15	Resistor	110 $\Omega$	0.5%		
R16	Resistor	200k $\Omega$	5%		

Note: VISHAY SILICONIX : VISHAY Intertechnology, Inc.  
MOTOROLA : Motorola Japan Ltd.  
SUMIDA : SUMIDA ELECTRIC CO., Ltd.

# MB3875/3877

## REFERENCE DATA

### • MB3875

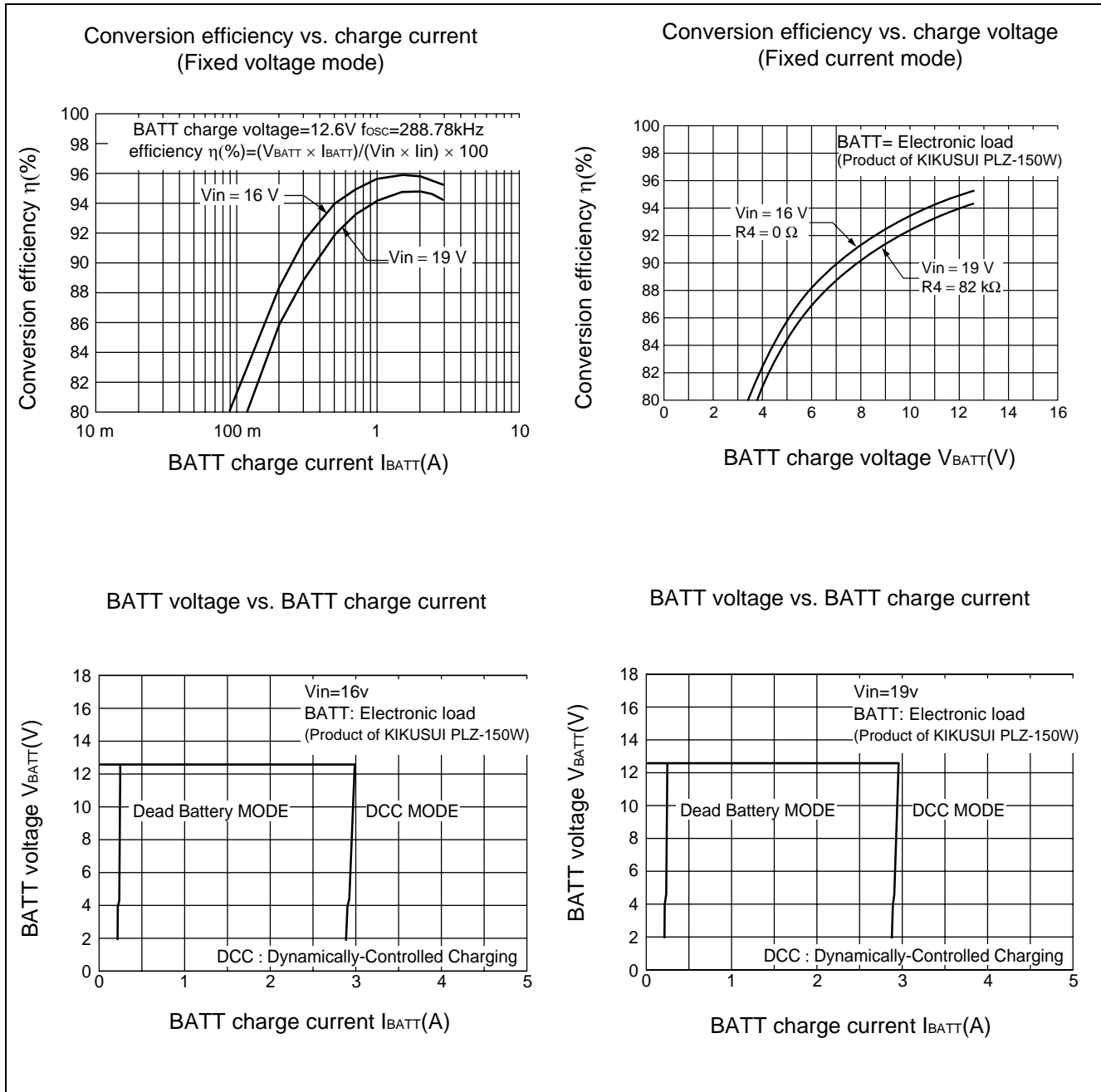

Note: KIKUSUI : KIKUSUI Electronics Corp.

(Continued)

### Soft-start operating waveforms

$V_{in} = 16\text{ V}$   
 Load: BATT =  $20\ \Omega$   
 - INE1 = 0 V

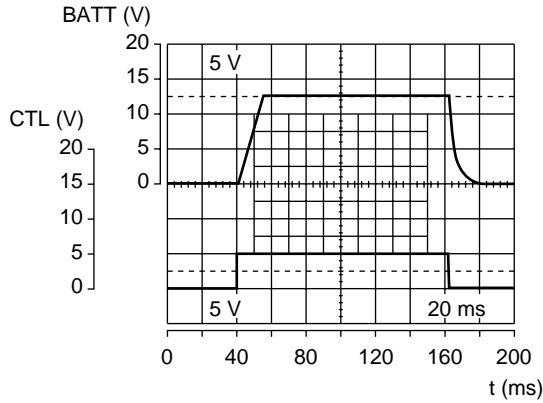

### DC/DC converter switching waveforms

$V_{in} = 16\text{ V}$   
 $F_{osc} = 288.8\text{ kHz}$   
 Load: BATT = 2A

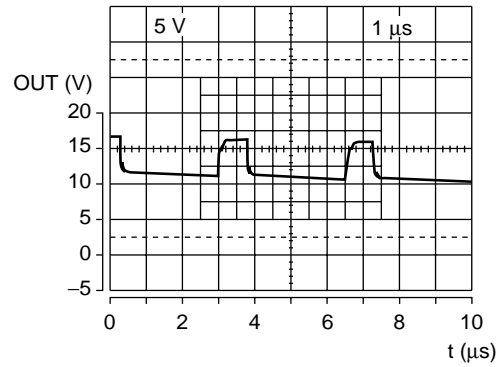

### Soft-start operating waveforms

$V_{in} = 19\text{ V}$   
 Load: BATT =  $20\ \Omega$   
 - INE1 = 0 V

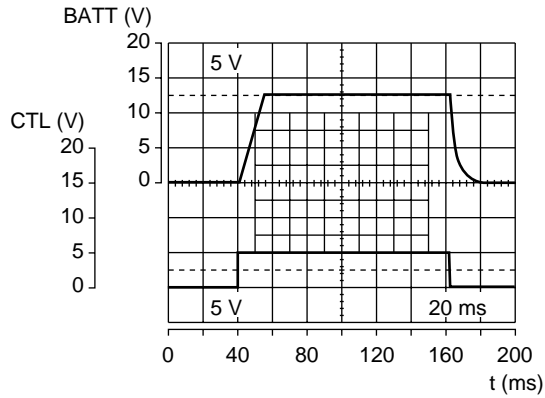

### DC/DC converter switching waveforms

$V_{in} = 19\text{ V}$   
 $F_{osc} = 288.8\text{ kHz}$   
 Load: BATT = 2A

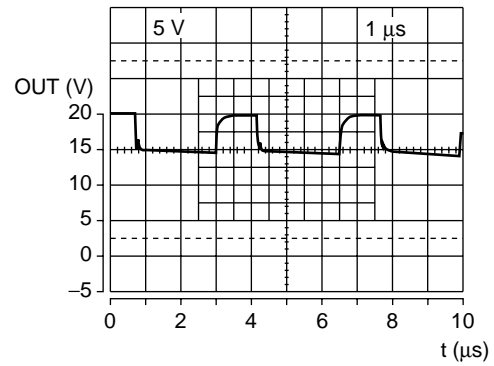

# MB3875/3877

• MB3877

Conversion efficiency vs. charge current

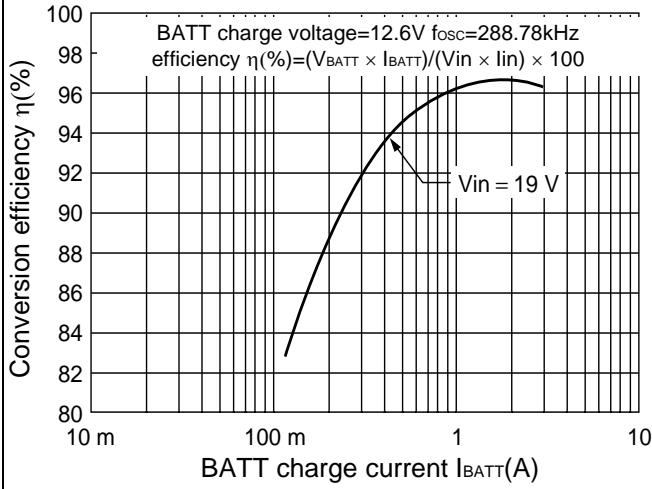

Conversion efficiency vs. charge voltage

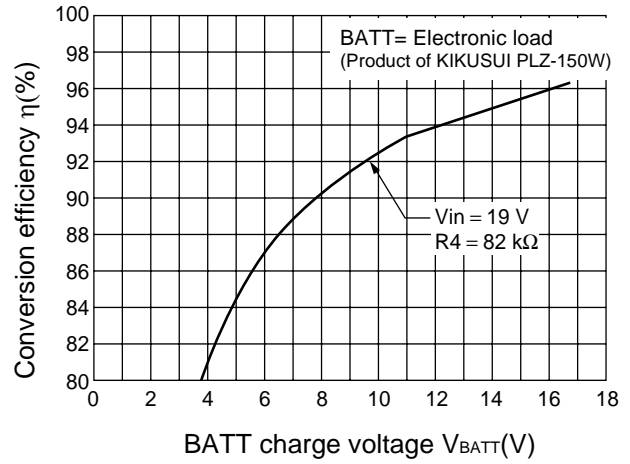

BATT voltage vs. BATT charge current

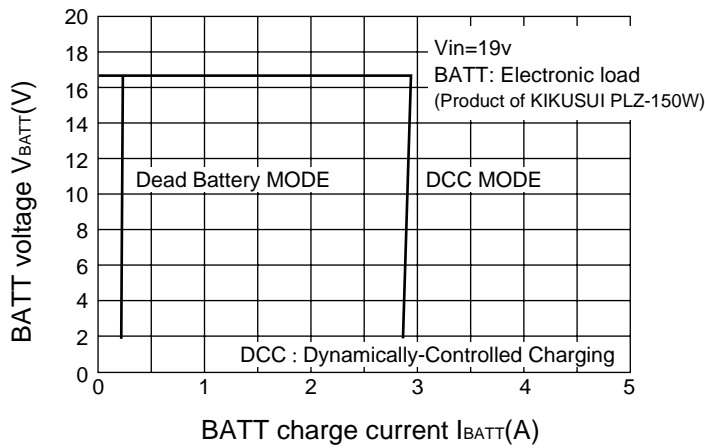

Note: KIKUSUI : KIKUSUI Electronics Corp.

(Continued)

### Soft-start operating waveforms

$V_{in} = 19\text{ V}$   
Load: BATT =  $50\ \Omega$   
- INE1 = 0 V

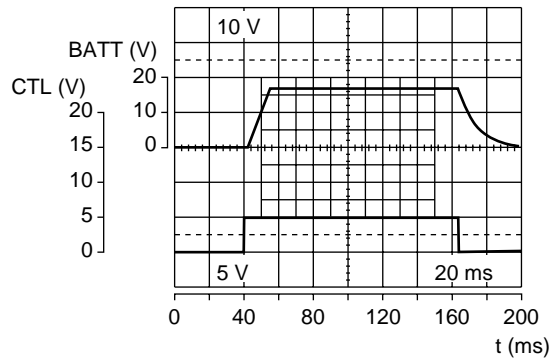

### DC/DC converter switching waveforms

$V_{in} = 19\text{ V}$   
 $F_{osc} = 287.4\text{ kHz}$   
Load: BATT = 2 A

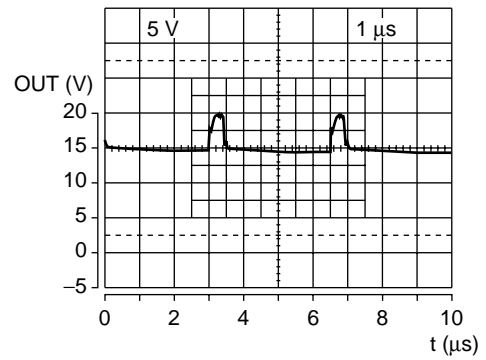

# MB3875/3877

## ■ NOTES ON USE

- Take account of common impedance when designing the earth line on a printed wiring board.
- Take measures against static electricity.
  - For semiconductors, use antistatic or conductive containers.
  - When storing or carrying a printed circuit board after chip mounting, put it in a conductive bag or container.
  - The work table, tools and measuring instruments must be grounded.
  - The worker must put on a grounding device containing 250 k $\Omega$  to 1 M $\Omega$  resistors in series.
- Do not apply a negative voltage
  - Applying a negative voltage of  $-0.3$  V or less to an LSI may generate a parasitic transistor, resulting in malfunction.

## ■ ORDERING INFORMATION

Part number	Package	Remarks
MB3875PFV MB3877PFV	24-pin plastic SSOP (FPT-24P-M03)	

## ■ PACKAGE DIMENSION

24-pin plastic SSOP  
(FPT-24P-M03)

Note 1) \*1 : Resin protrusion. (Each side : +0.15 (.006) MAX) .  
 Note 2) \*2 : These dimensions do not include resin protrusion.  
 Note 3) Pins width and pins thickness include plating thickness.  
 Note 4) Pins width do not include tie bar cutting remainder.

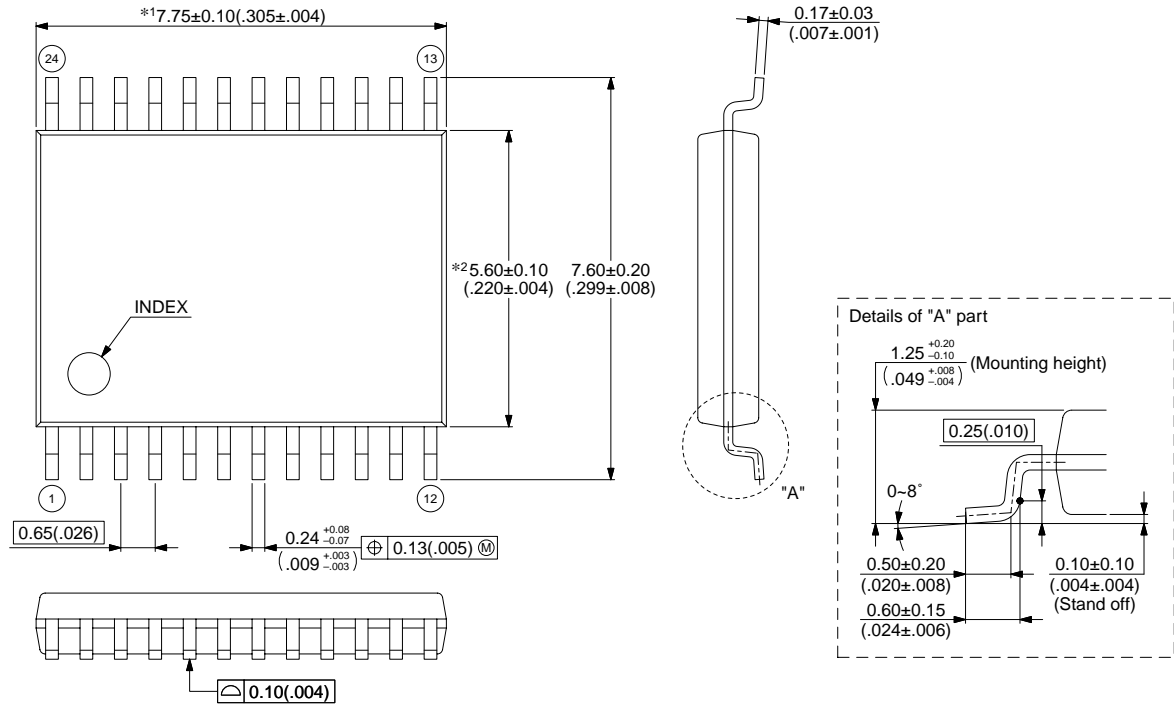

© 2003 FUJITSU LIMITED F24018S-c-4-5

Dimensions in mm (inches) .

Note : The values in parentheses are reference values.

**MEMO**

**MEMO**

# FUJITSU MICROELECTRONICS LIMITED

Shinjuku Dai-Ichi Seimei Bldg. 7-1, Nishishinjuku 2-chome, Shinjuku-ku,  
Tokyo 163-0722, Japan Tel: +81-3-5322-3347 Fax: +81-3-5322-3387  
<http://jp.fujitsu.com/fml/en/>

*For further information please contact:*

## **North and South America**

FUJITSU MICROELECTRONICS AMERICA, INC.  
1250 E. Arques Avenue, M/S 333  
Sunnyvale, CA 94085-5401, U.S.A.  
Tel: +1-408-737-5600 Fax: +1-408-737-5999  
<http://www.fma.fujitsu.com/>

## **Europe**

FUJITSU MICROELECTRONICS EUROPE GmbH  
Pittlerstrasse 47, 63225 Langen,  
Germany  
Tel: +49-6103-690-0 Fax: +49-6103-690-122  
<http://emea.fujitsu.com/microelectronics/>

## **Korea**

FUJITSU MICROELECTRONICS KOREA LTD.  
206 KOSMO TOWER, 1002 Daechi-Dong,  
Kangnam-Gu, Seoul 135-280  
Korea  
Tel: +82-2-3484-7100 Fax: +82-2-3484-7111  
<http://www.fmk.fujitsu.com/>

## **Asia Pacific**

FUJITSU MICROELECTRONICS ASIA PTE LTD.  
151 Lorong Chuan, #05-08 New Tech Park,  
Singapore 556741  
Tel: +65-6281-0770 Fax: +65-6281-0220  
<http://www.fujitsu.com/sg/services/micro/semiconductor/>

FUJITSU MICROELECTRONICS SHANGHAI CO., LTD.  
Rm.3102, Bund Center, No.222 Yan An Road(E),  
Shanghai 200002, China  
Tel: +86-21-6335-1560 Fax: +86-21-6335-1605  
<http://cn.fujitsu.com/fmc/>

FUJITSU MICROELECTRONICS PACIFIC ASIA LTD.  
10/F., World Commerce Centre, 11 Canton Road  
Tsimshatsui, Kowloon  
Hong Kong  
Tel: +852-2377-0226 Fax: +852-2376-3269  
<http://cn.fujitsu.com/fmc/tw>

All Rights Reserved.

The contents of this document are subject to change without notice.

Customers are advised to consult with sales representatives before ordering.

The information, such as descriptions of function and application circuit examples, in this document are presented solely for the purpose of reference to show examples of operations and uses of FUJITSU MICROELECTRONICS device; FUJITSU MICROELECTRONICS does not warrant proper operation of the device with respect to use based on such information. When you develop equipment incorporating the device based on such information, you must assume any responsibility arising out of such use of the information.

FUJITSU MICROELECTRONICS assumes no liability for any damages whatsoever arising out of the use of the information.

Any information in this document, including descriptions of function and schematic diagrams, shall not be construed as license of the use or exercise of any intellectual property right, such as patent right or copyright, or any other right of FUJITSU MICROELECTRONICS or any third party or does FUJITSU MICROELECTRONICS warrant non-infringement of any third-party's intellectual property right or other right by using such information. FUJITSU MICROELECTRONICS assumes no liability for any infringement of the intellectual property rights or other rights of third parties which would result from the use of information contained herein.

The products described in this document are designed, developed and manufactured as contemplated for general use, including without limitation, ordinary industrial use, general office use, personal use, and household use, but are not designed, developed and manufactured as contemplated (1) for use accompanying fatal risks or dangers that, unless extremely high safety is secured, could have a serious effect to the public, and could lead directly to death, personal injury, severe physical damage or other loss (i.e., nuclear reaction control in nuclear facility, aircraft flight control, air traffic control, mass transport control, medical life support system, missile launch control in weapon system), or (2) for use requiring extremely high reliability (i.e., submersible repeater and artificial satellite).

Please note that FUJITSU MICROELECTRONICS will not be liable against you and/or any third party for any claims or damages arising in connection with above-mentioned uses of the products.

Any semiconductor devices have an inherent chance of failure. You must protect against injury, damage or loss from such failures by incorporating safety design measures into your facility and equipment such as redundancy, fire protection, and prevention of over-current levels and other abnormal operating conditions.

Exportation/release of any products described in this document may require necessary procedures in accordance with the regulations of the Foreign Exchange and Foreign Trade Control Law of Japan and/or US export control laws.

The company names and brand names herein are the trademarks or registered trademarks of their respective owners.