

ASSP For Power Supply Applications

Power Management 2-ch Switch IC

MB3842/MB3845

DESCRIPTION

The MB3842/3845 is a power management switch with built-in 2-channel low-on resistance (typ. 100m Ω) switch. Output control is by means of a control signal, and the MB3842 is designed for high-active operation (output on when EN is Hi), while the MB3845 is designed for low-active operation (output on when $\overline{\text{EN}}$ is low.)

To provide adaptability to a variety of operations, the MB3842/3845 features low input voltage ($V_{\text{IN}} > 2.5\text{V}$) operation and stable low-on resistance independent of input voltage. The switching current limit can be set from 100mA to 600mA by using external resistance, and when overcurrent conditions are detected the OC output goes low to provide an external notification signal.

V_{IN} is divided between the two channels, which operate independently of each other.

In addition, an off-state reverse current prevention function is provided to ensure accurate on/off switching action.

FEATURES

- Low on resistance switch (typ. 100m Ω)
- Low input voltage operation (2.5 V to 5.5 V)
- Switch current (max. 0.6 A)
- UVLO : V_{IN} threshold 2.3V/2.1 V hysteresis 200 mV
- ENABLE : EN threshold EN 1.4V/1.6 V for MB3842, $\overline{\text{EN}}$ 1/2 V_{IN} for MB3845
- : Power supply current at output off = 0 μA EN < 0.8V for MB3842, $\overline{\text{EN}} = V_{\text{IN}}$ for MB3845
- External setting for soft start time and switch current limit.
- Over-temperature detection (switch latched off), over-current detection (not latched)
- OC pin flag set following overcurrent detection, over-temperature detection, or UVLO detection.
- Reverse current prevention at OFF ($V_{\text{IN}} \geq 1.5\text{ V}$)
- Either channel may be operated alone.

PACKAGE

20-pin plastic SSOP

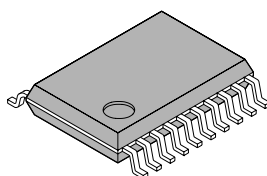

(FPT-20P-M03)

MB3842/MB3845

■ PIN ASSIGNMENT

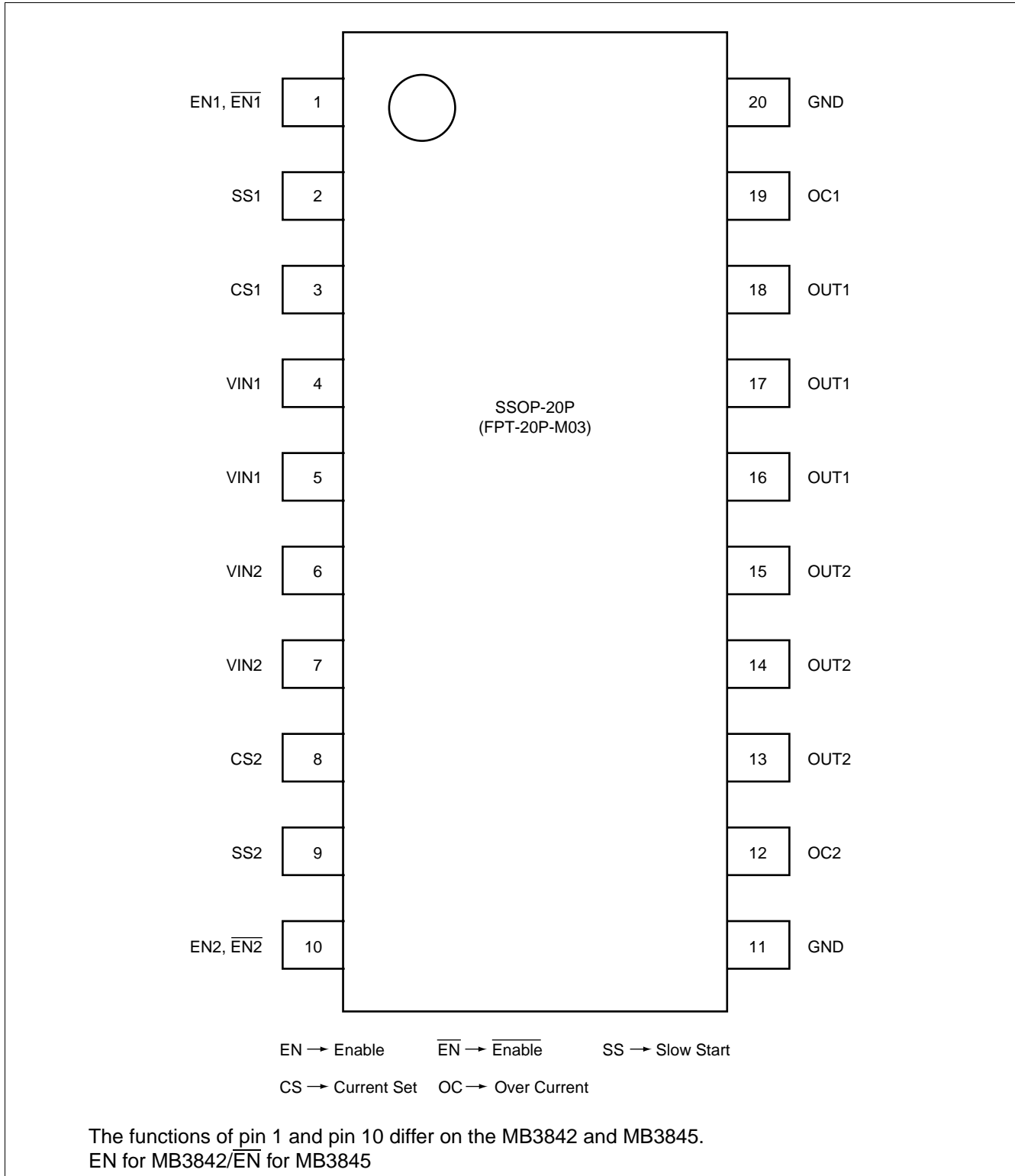

■ PIN DESCRIPTION

Pin no.	Symbol	Descriptions
1/10	EN (MB3842)	Control signal input pin. Set "H" to turn switch on, "L" to turn toff. At 0.8 V or less, the chip is in STBY state and current consumption is less than 1 μ A. "L" level is 1.4V (typ), "H" level is 1.6V (typ), with 200mV (typ) hysteresis.
	$\overline{\text{EN}}$ (MB3845)	Control signal input pin. Set "L" to turn switch on, "H" to turn off. At "H" level = V_{IN} , the chip is in STBY state and current consumption is less than 1 μ A. Normally used as CMOS inverter input, so that recommended use is "L" level at GND +0.5V or less, and "H" level is V_{IN} -0.5V or greater.
2/9	SS	Slow start setting pin. Used to adjust the switch on/off timing. Add external capacitance to delay operation. Leave open when not in use. In open mode voltages up to 12 V are present. Care should be taken in mounting to prevent leakage current generation because high impedance is required.
3/8	CS	Current limit setting pin. The limit current level is set by connecting this pin to external resistance.
4/5/6/7	VIN	Switch output pin. An UVLO (V_{IN} power monitor function) is provided so that when V_{IN} reaches 2.3V (typ.) or higher the OC pin voltage goes to "H" level. Also if the V_{IN} voltage drops to 2.1 V (typ.) or lower the OC output goes to "L" state. 200mV (typ) hysteresis is provided.
11/20	GND	Ground pin.
12/19	OC	External notification pin. When the switch is in on mode this pin normally outputs a "H" level signal, but changes to "L" level when an overcurrent, overtemperature, or UVLO condition is detected. This is an open drain connection, and should be pulled up to high potential using resistance.
13/14/15 16/17/18	OUT	Switching output pin.(N-ch MOSFET source)

MB3842/MB3845

■ BLOCK DIAGRAM (for 1 channel)

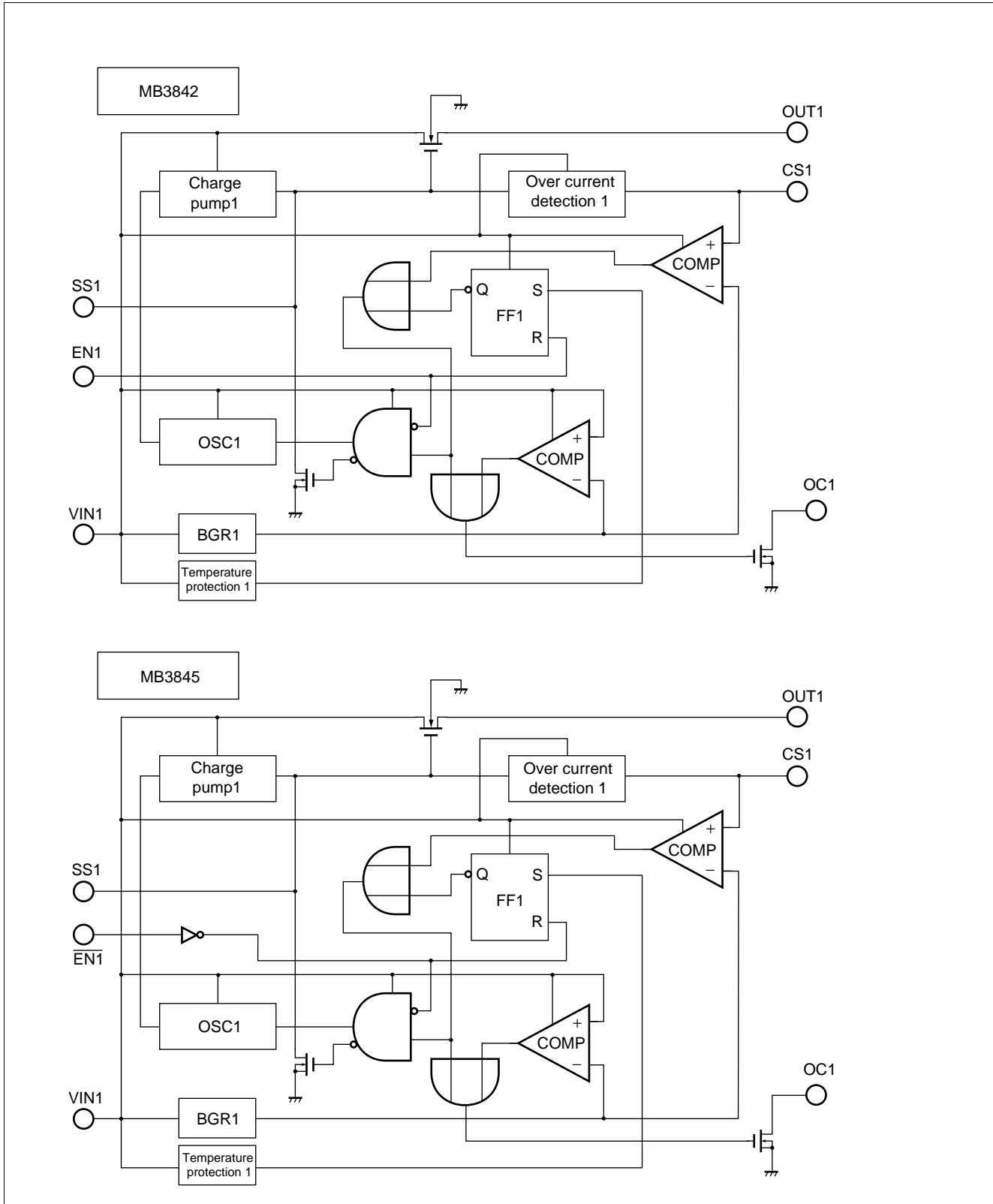

■ ABSOLUTE MAXIMUM RATINGS

Parameter	Symbol	Condition	Rating		Unit
			Max.	Min.	
Input voltage	V_{IN}	—	-0.3	7.0	V
ENABLE voltage	V_{EN}	—	-0.3	7.0	V
Switch current	I_{SW}	—	—	1.8	A
Power dissipation	P_D	$T_a = +85^{\circ}\text{C}$	—	216	mW
Storage temperature	T_{STG}	—	-55	+125	$^{\circ}\text{C}$

WARNING: Semiconductor devices can be permanently damaged by application of stress (voltage, current, temperature, etc.) in excess of absolute maximum ratings. Do not exceed these ratings.

■ RECOMMENDED OPERATING CONDITIONS

Parameter	Symbol	Condition	Value			Unit
			Min.	Typ.	Max.	
Input voltage	V_{IN}	—	2.5	5.0	5.5	V
ENABLE voltage	V_{EN}	$V_{EN} \leq V_{IN}$	0	—	5.5	V
Switch current	I_{SW}	$V_{IN} = 2.5\text{ V to }5.5\text{ V}$	—	—	0.6	A
SS pin capacitance	C_{SS}^*	—	—	—	10	nF
OC sink current	I_{OCS}	$V_{IN} = 5.0\text{ V}, V_{OC} = 0.4\text{ V}$	2.0	5.0	—	mA
Current limit resistance	R_{LIM}^*	$V_{IN} = 5.0\text{ V} (I_{SW} = 0.6\text{ A})$	1.4	2.0	2.6	$k\Omega$
		$V_{IN} = 5.0\text{ V} (I_{SW} = 0.1\text{ A})$	3.6	6.2	9.1	$k\Omega$
Operating temperature	T_{OP}	—	-20	—	+85	$^{\circ}\text{C}$

* : For C_{SS} , R_{LIM} settings, see "TYPICAL CHARACTERISTICS" and "FUNCTIONAL DESCRIPTION".

WARNING: The recommended operating conditions are required in order to ensure the normal operation of the semiconductor device. All of the device's electrical characteristics are warranted when the device is operated within these ranges.

Always use semiconductor devices within their recommended operating condition ranges. Operation outside these ranges may adversely affect reliability and could result in device failure.

No warranty is made with respect to uses, operating conditions, or combinations not represented on the data sheet. Users considering application outside the listed conditions are advised to contact their representatives beforehand.

MB3842/MB3845

■ ELECTRICAL CHARACTERISTICS (per 1 ch)

• MB3842/MB3845

($V_{IN} = 5\text{ V}$, $T_a = +25^\circ\text{C}$)

Parameter	Symbol	Condition	Value			Unit
			Min.	Typ.	Max.	
Switch resistance	R_{ON}	$I_{SW} = 0.6\text{ A}$	—	100	150	$\text{m}\Omega$
IN pin input current	I_{IN1}	$I_{SW} = 0\text{ A}$	—	350	550	μA
	I_{IN2}	$I_{SW} = 0.6\text{ A}$	—	1.0	1.5	mA
	I_{IN3}	$\overline{\text{EN}} < 0.8\text{ V}$ for MB3842, $\overline{\text{EN}} = V_{IN}$ for MB3845	—	—	1.0	μA
UVLO threshold	V_{IUH}	V_{IN} at OC = L \rightarrow H	2.1	2.3	2.5	V
	V_{IUL}	V_{IN} at OC = H \rightarrow L	1.9	2.1	2.3	V
UVLO hysteresis width	V_{IUHY}	$V_{IUHY} = V_{IUH} - V_{IUL}$	100	200	300	mV
Switch current limit	I_{SWH}	$R_{LIM} = 2.0\text{ k}\Omega$	0.42	0.6	0.78	A
	I_{SWL}	$R_{LIM} = 6.2\text{ k}\Omega$	0.06	0.1	0.14	A
OC sink current	I_{OCS}	$V_{OC} = 0.4\text{ V}$ at OC active	2.0	5.0	—	mA
	I_{OCL}	$V_{OC} = 5.0\text{ V}$ at OC non-active	—	—	1.0	μA
Temperature protection (T_j)	T_{LIM}	—	+125	—	—	$^\circ\text{C}$
OUT pin rise time	t_{ON}	SS pin: Open OUT pin: $100\text{ k}\Omega$ pull down	—	100	200	μs
OUT pin fall time	t_{OFF}	SS pin: Open OUT pin: $100\text{ k}\Omega$ pull down	—	50	120	μs

• MB3842

($V_{IN} = 5\text{ V}$, $T_a = +25^\circ\text{C}$)

Parameter	Symbol	Condition	Value			Unit
			Min.	Typ.	Max.	
ENABLE pin input current	I_{ENH}	$V_{EN} = 5\text{ V}$, $I_{SW} = 0\text{ A}$	—	5	10	μA
	I_{ENL}	$V_{EN} = 0\text{ V}$, $I_{SW} = 0\text{ A}$	—	0.0	—	μA
ENABLE pin threshold voltage	V_{THEN}	—	1.45	1.60	1.75	V
	V_{TLEN}	—	1.25	1.40	1.55	V
ENABLE hysteresis width	V_{ENHY}	$V_{ENHY} = V_{THEN} - V_{TLEN}$	100	200	300	mV

• MB3845

($V_{IN} = 5\text{ V}$, $T_a = +25^\circ\text{C}$)

Parameter	Symbol	Condition	Value			Unit
			Min.	Typ.	Max.	
$\overline{\text{ENABLE}}$ pin input current	I_{ENH}	$V_{EN} = 5\text{ V}$, $I_{SW} = 0\text{ A}$	—	0.0	—	μA
	I_{ENL}	$V_{EN} = 0\text{ V}$, $I_{SW} = 0\text{ A}$	—	0.0	—	μA
$\overline{\text{ENABLE}}$ pin input voltage	V_{ILEN}	—	0	—	0.8	V
	V_{IHEN}	—	3.0	—	5.0	V

■ DIAGRAM

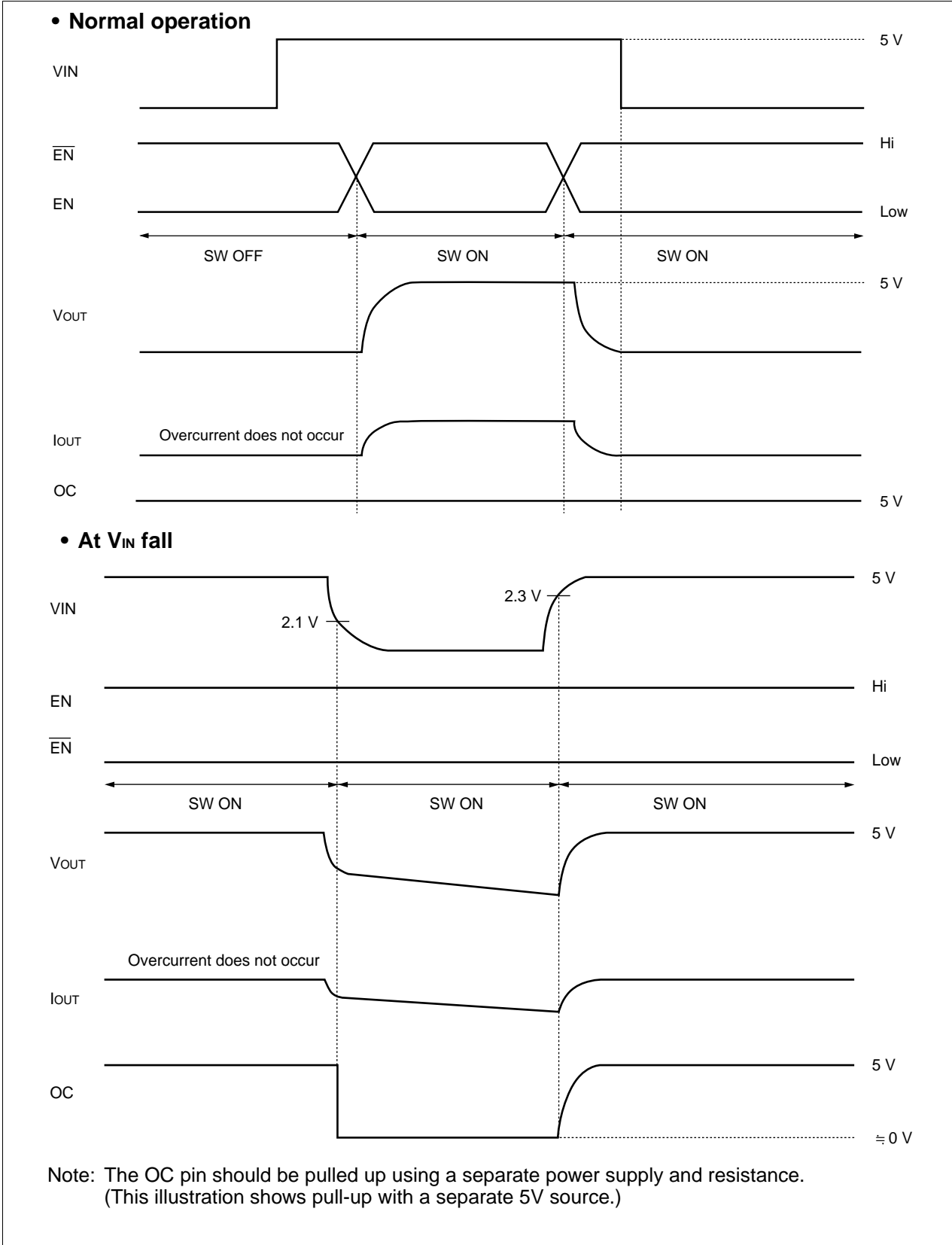

(Continued)

MB3842/MB3845

(Continued)

• At overcurrent detection

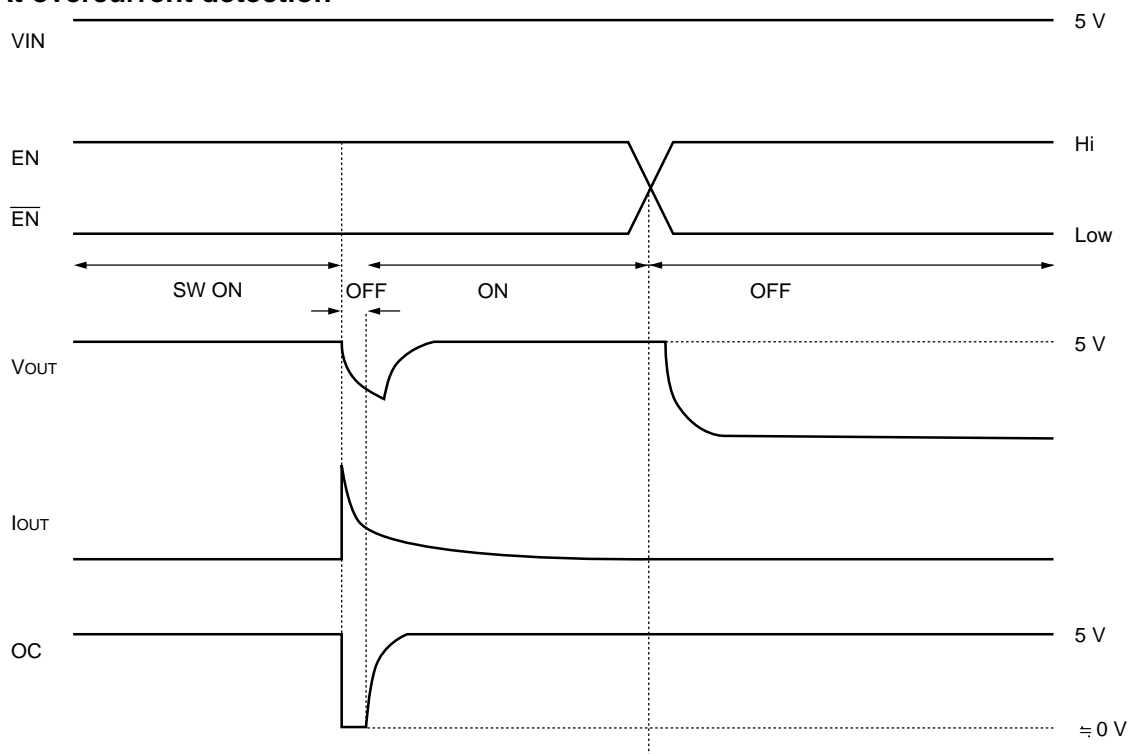

• At over-temperature occurrence

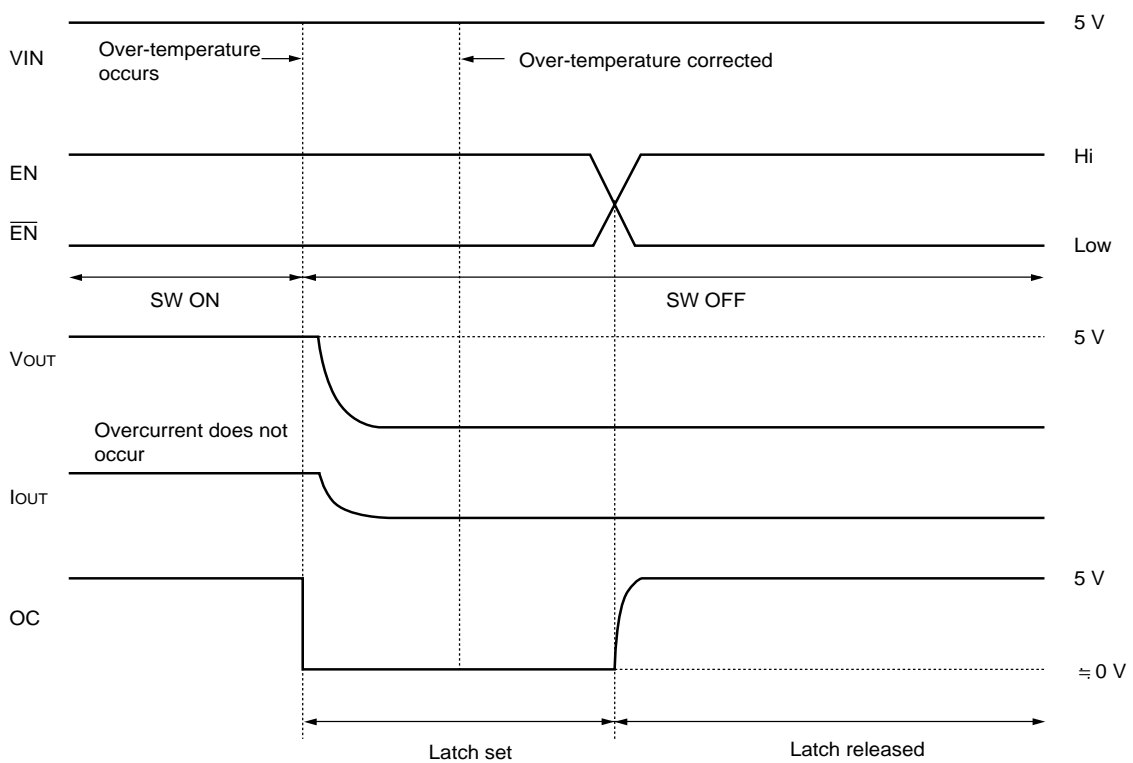

Note: The OC pin should be pulled up using a separate power supply and resistance. (This illustration shows pull-up with a separate 5V source.)

■ TYPICAL CHARACTERISTICS

• R_{LIM} vs. limit current characteristics

These are the limiting value characteristics for CS pin-to-GND external resistance and output current (OC flag).

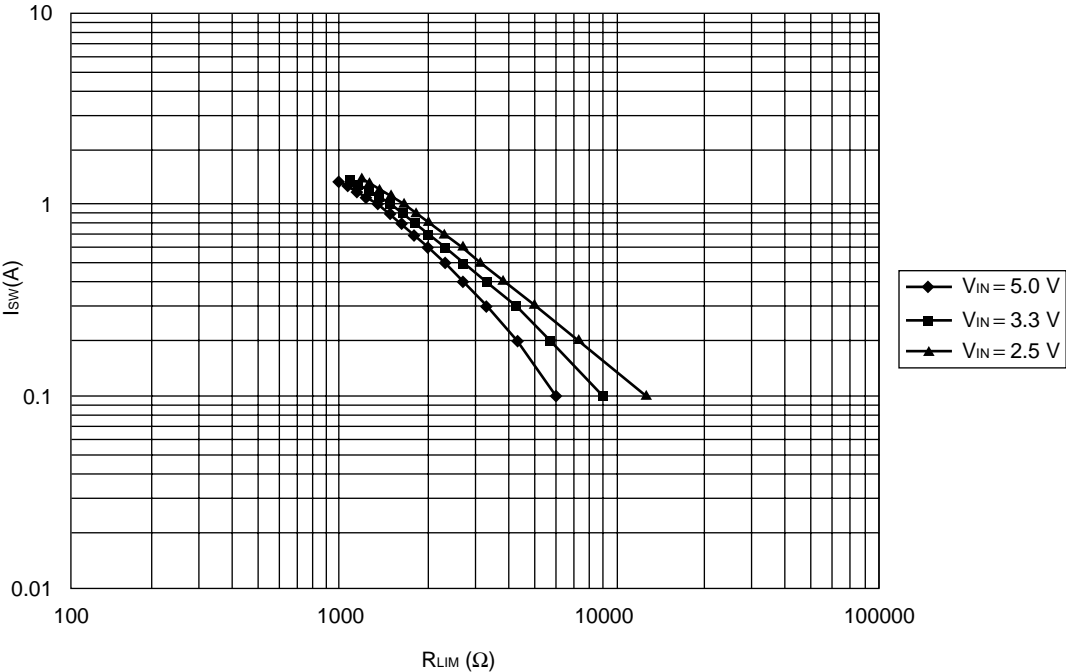

• C_{SS} vs. T_{ON} (SS) characteristics

There are the characteristics for SS pin-to-GND external capacitance and output ON time.

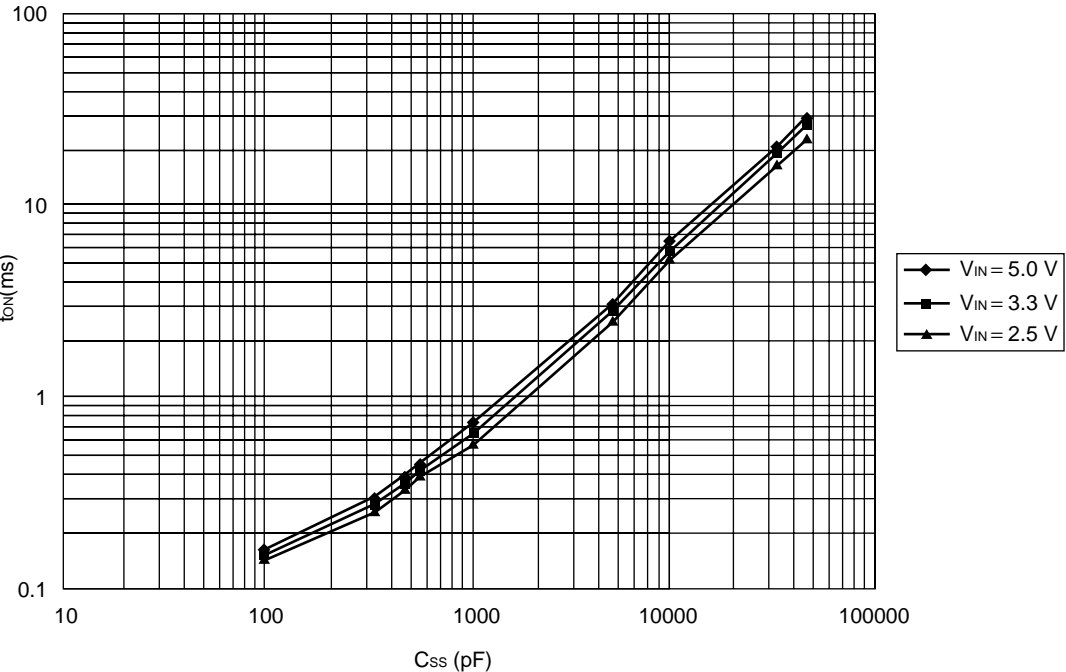

(Continued)

(Continued)

• SW resistance vs. temperature characteristics

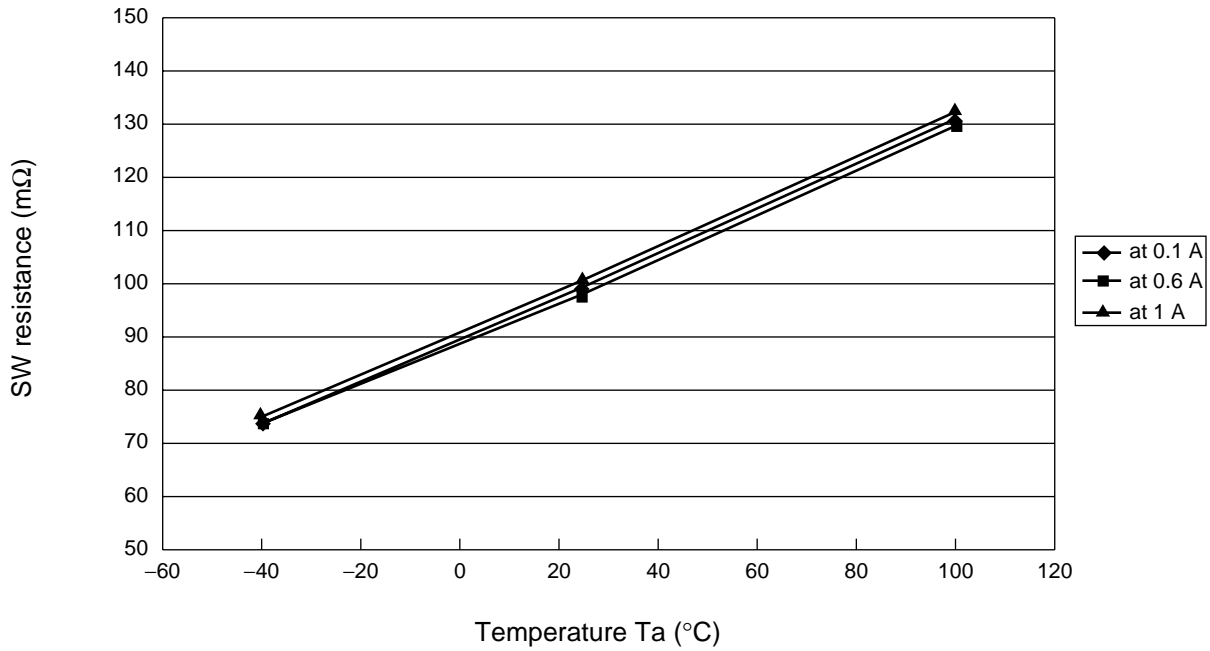

• Temperature-dependent SW resistance vs. V_{IN} (V) characteristics

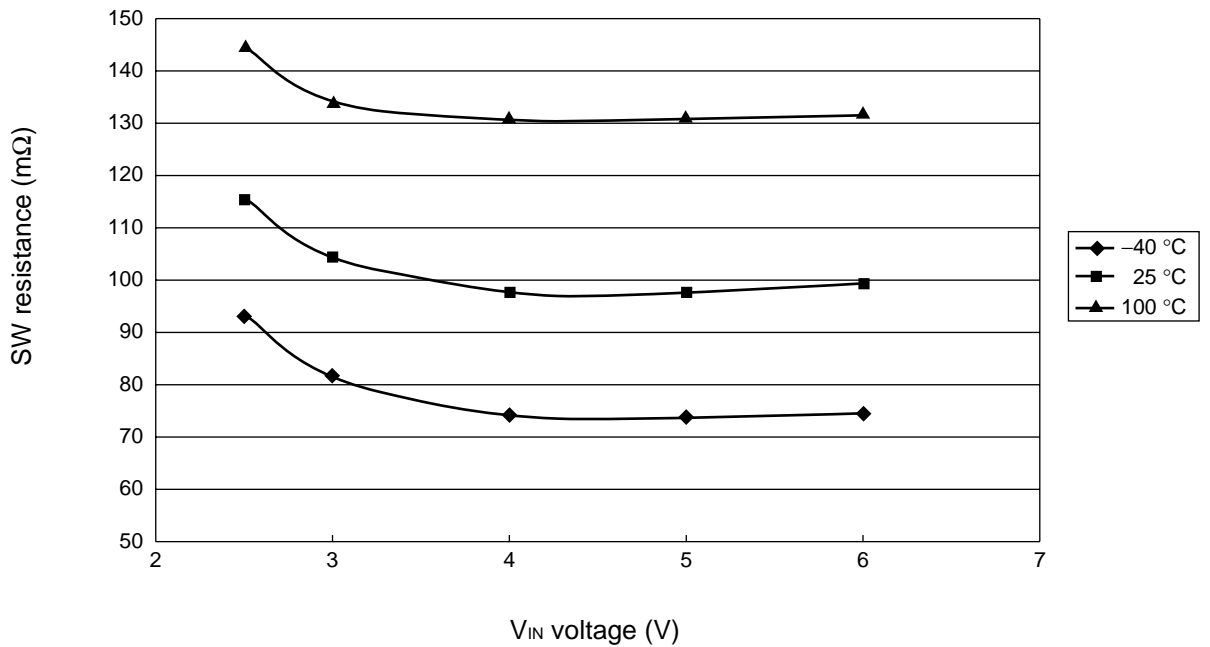

(Continued)

(Continued)

• OC pin flag pull-up resistance (pull-up power 5V) dependant overcurrent operation

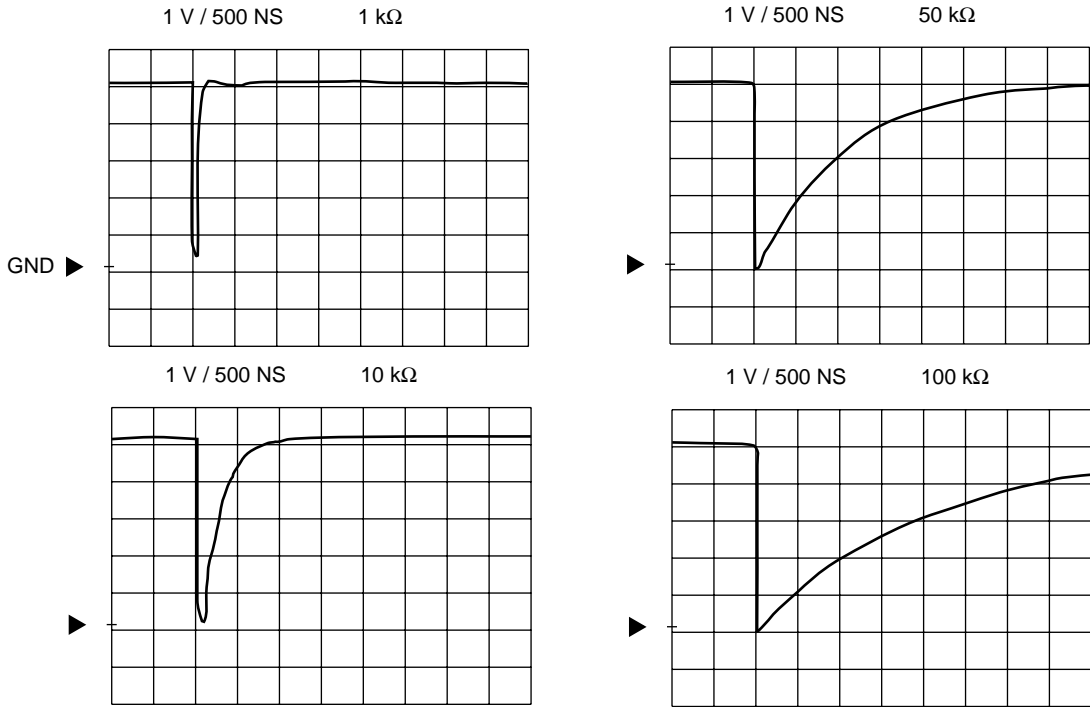

• Power derating characteristics

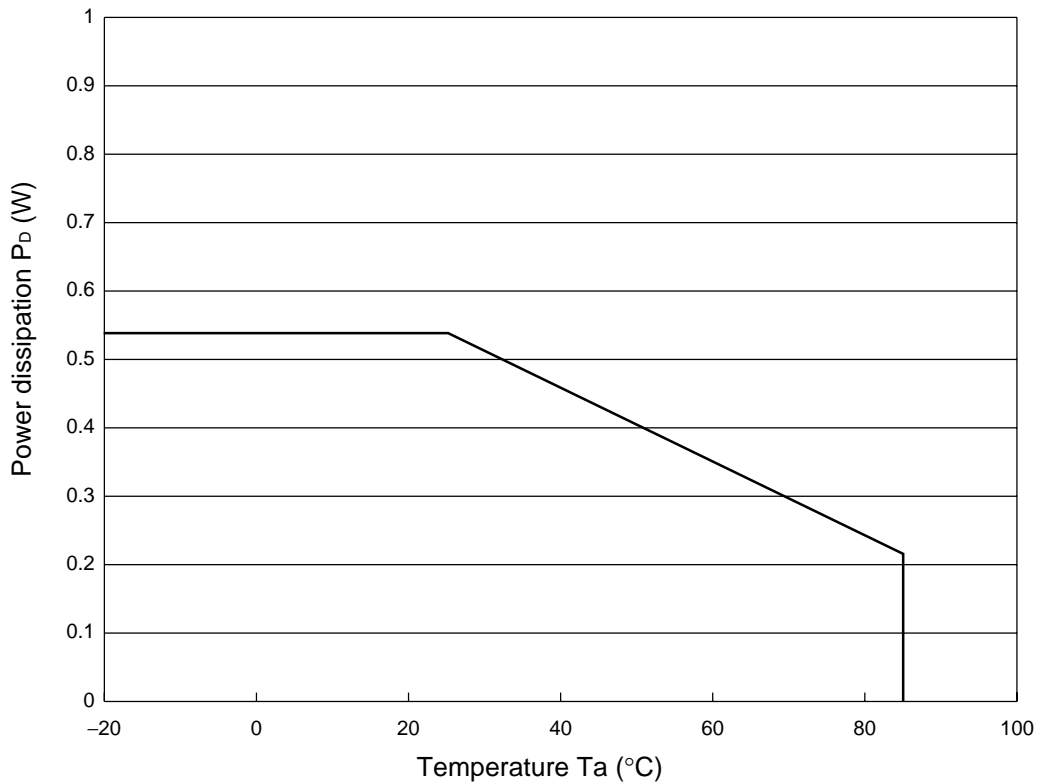

■ FUNCTIONAL DESCRIPTION

Current Limit Setting

By placing resistance between the CS and GND pins, the current limit can be set between 100mA and 600mA within $\pm 30\%$ accuracy ($V_{IN} = 5\text{ V}$, current limit at 600mA). Because the setting value is dependent on V_{IN} voltage, the user should select the optimum resistance value for the value of V_{IN} voltage. When the switching current exceeds the set value, the OC pin goes to “L” level as an external notification signal, but there is no latching function. To hold operation on “off” state, the input signal to the EN and $\overline{\text{EN}}$ pins should be used.

When a direct connection to GND is used, there is no current limitation.

When the connection is open, the switch is in a state of continuously held current limits.

Thermal Shutdown

The MB3842/MB3845 has a thermal shutdown function which turns the switch off and sets the latch to protect the device when junction temperature exceeds 125°C .

At the same time the OC output signal goes to “L” level to notify external systems.

The latch function can be reset by sending a low signal to the EN input of the MB3842, or a high signal to the $\overline{\text{EN}}$ input of the MB3845.

Slow Start

The on/off switching time can be delayed by applying capacitance between the SS and GND pins. Controlling the on time can soften surge current to the load side capacitance when power is turned on.

For details, see “ C_{SS} vs. t_{ON} (SS) characteristics” on p. 9.

UVLO

A V_{IN} voltage monitoring function is provided, so that when V_{IN} voltage exceeds 2.3 V (typ) the OC pin voltage goes to “H” level. When V_{IN} voltage falls below 2.1V (typ), the OC output goes to “L” state.

Error Flag OC Pin

The OC pin produces a “L” signal in case of a UVLO, overcurrent, or over-temperature condition. In case of overcurrent, the output has a pulse waveform. See P12.

(note) Output current limit setting resistance values are shown on P9, and in the following table. (CS pin-to-GND)

Standard Values

V_{IN}/I_{SW}	0.1 A	0.2 A	0.3 A	0.4 A	0.5 A	0.6 A	0.7 A	0.8 A	0.9 A	1.0 A
$V_{IN} 5.0\text{V}$	6.2 k Ω	4.3 k Ω	3.3 k Ω	2.7 k Ω	2.2 k Ω	2.0 k Ω	1.8 k Ω	1.6 k Ω	1.4 k Ω	1.3 k Ω
$V_{IN} 3.3\text{V}$	9.1 k Ω	5.6 k Ω	4.3 k Ω	3.3 k Ω	2.7 k Ω	2.4 k Ω	2.0 k Ω	1.8 k Ω	1.6 k Ω	1.5 k Ω
$V_{IN} 2.5\text{V}$	13 k Ω	7.5 k Ω	5.1 k Ω	3.9 k Ω	3.0 k Ω	2.7 k Ω	2.2 k Ω	2.0 k Ω	1.8 k Ω	1.6 k Ω

MB3842/MB3845

■ TYPICAL APPLICATION

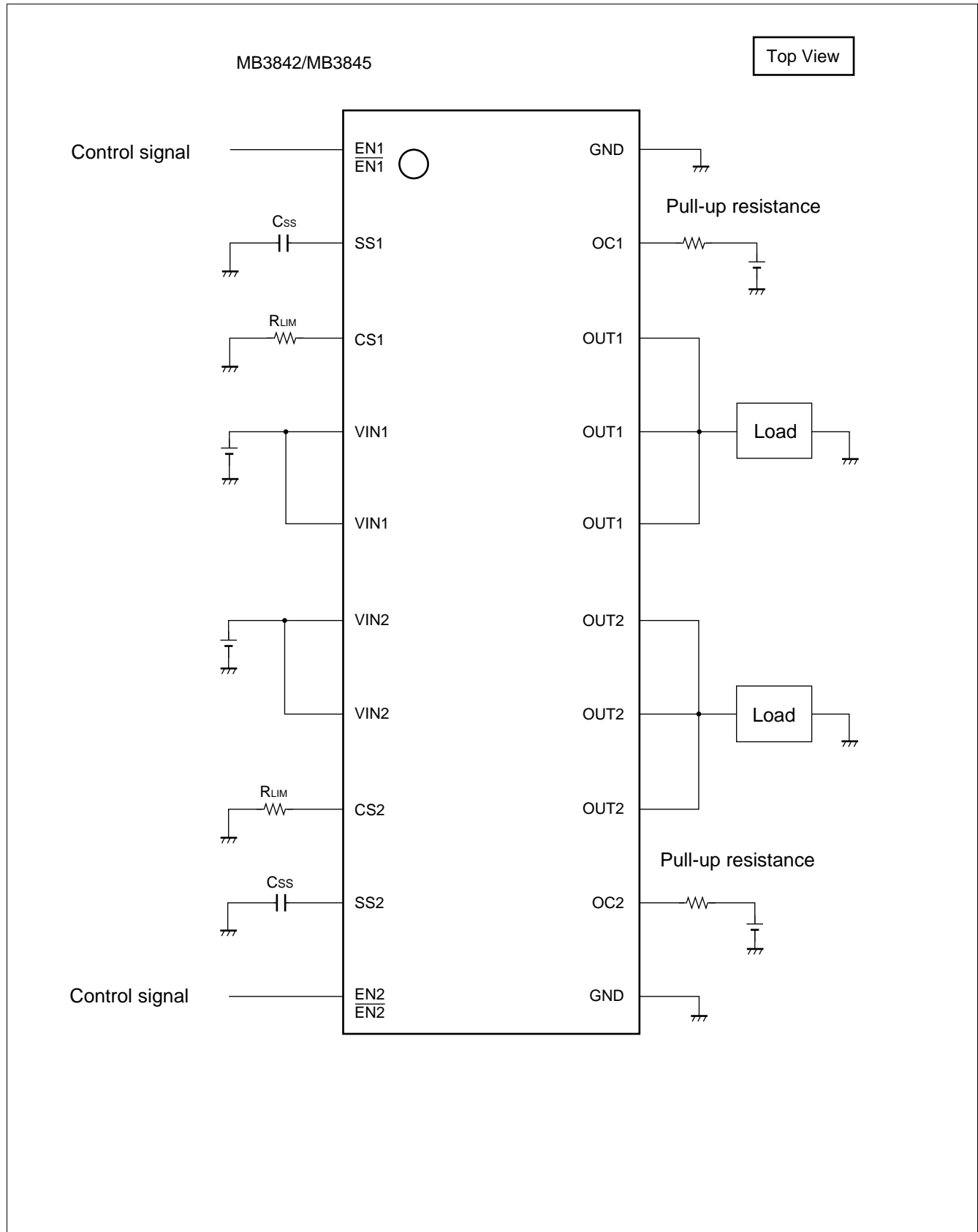

■ APPLICATION EXAMPLE

(1) Dual-Port Self-Powered Hub Application (NON-GANG Mode Connection)

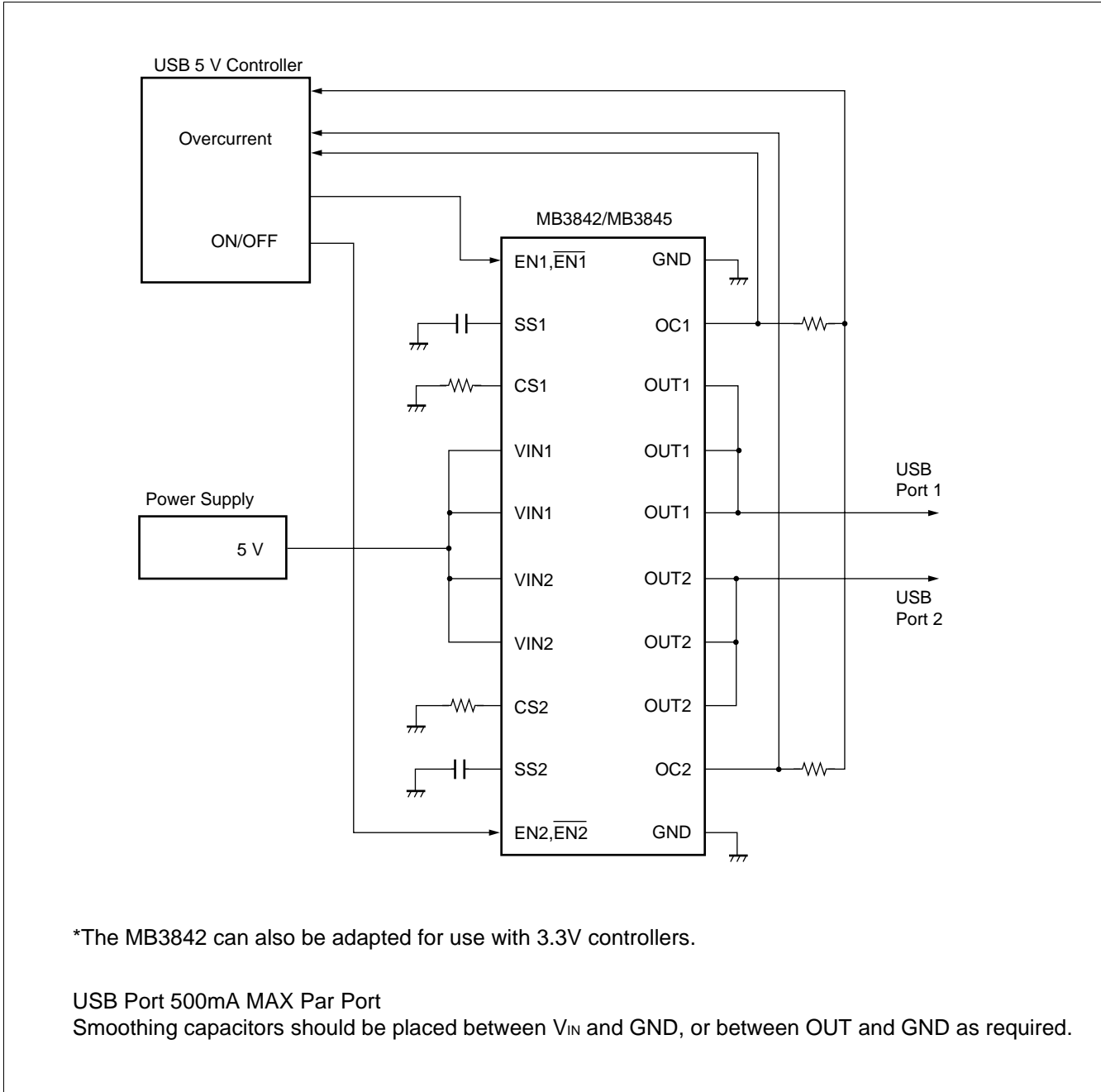

MB3842/MB3845

(2) Dual-Port Bus Powered Hub Application (GANG Mode Connection)

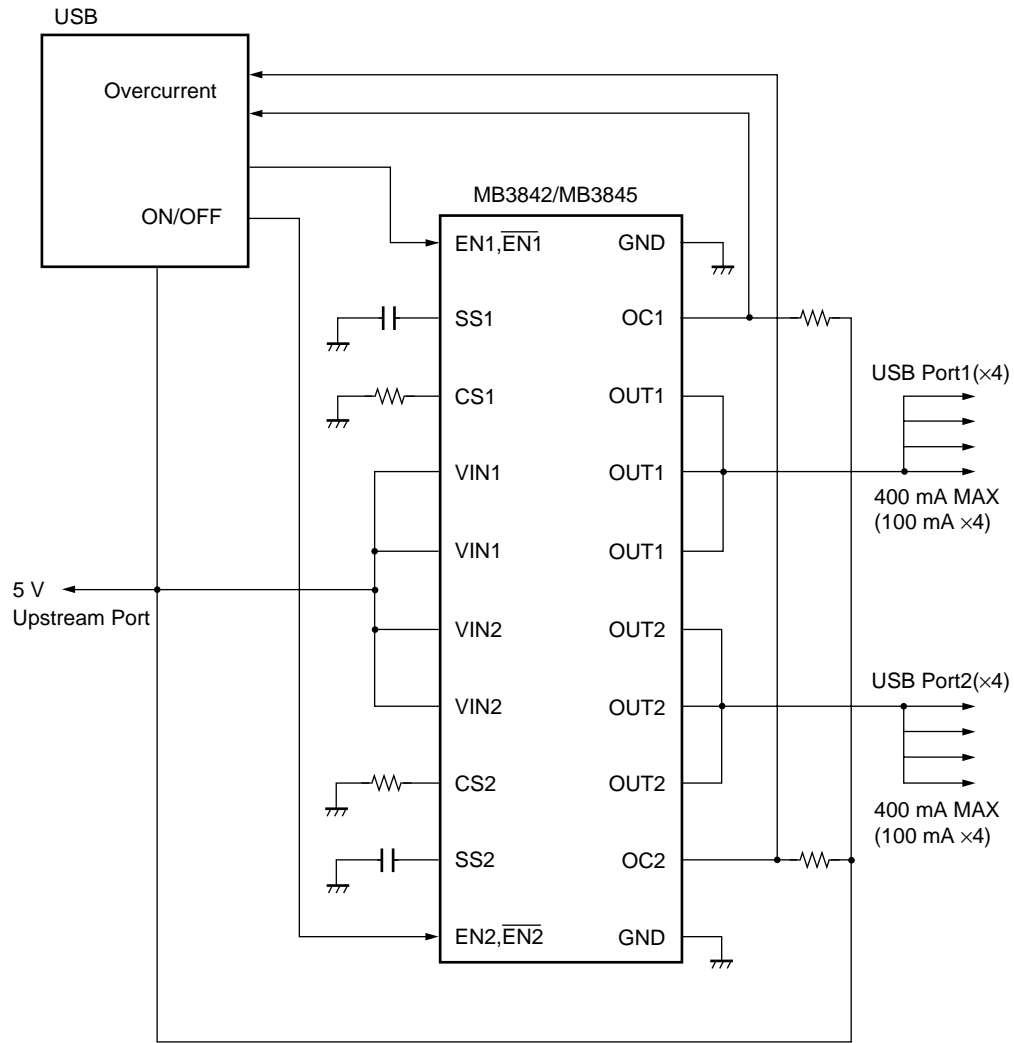

USB Port 100mA MAX Par Port

Smoothing capacitors should be placed between V_{IN} and GND, or between OUT and GND as required.

■ USAGE PRECAUTION

1. Never use settings exceeding maximum rated conditions.

Exceeding maximum rated conditions may cause permanent damage to the LSI.

Also, it is recommended that recommended operating conditions be observed in normal use. Exceeding recommended operating conditions may adversely affect LSI reliability.

2. Use this device within recommended operating conditions.

Recommended operating conditions are values within which normal LSI operation is warranted.

Standard electrical characteristics are warranted within the range of recommended operating conditions and within the listed conditions for each parameter.

3. Printed circuit board ground lines should be set up with consideration for common impedance.

4. Take appropriate static electricity measures.

- Containers for semiconductor materials should have anti-static protection or be made of conductive material.
- After mounting, printed circuit boards should be stored and shipped in conductive bags or containers.
- Work platforms, tools, and instruments should be properly grounded.
- Working personnel should be grounded with resistance of 250 kΩ to 1 MΩ between body and ground.

5. Do not apply negative voltages.

The use of negative voltages below -0.3 V may create parasitic transistors on LSI lines, which can cause abnormal operation.

6. Reverse Current Prevention Function

Current cannot flow back to the V_{IN} pin with the switch off, even when the OUT pin voltage is higher than the V_{IN} pin ($OUT \geq V_{IN}$), however when V_{IN} pin voltage is lower than 1.5 V circuit functions are lost, so that in this case there is danger of reverse current flow. For applications in which reverse flow is not acceptable, set $V_{IN} \geq 1.5\text{ V}$.

■ ORDERING INFORMATION

Part number	Package	Remarks
MB3842PFV MB3845PFV MB3845PFV-ER	20-pin Plastic SSOP (FPT-20P-M03)	

MB3842/MB3845

■ PACKAGE DIMENSION

20-pin plastic SSOP
(FPT-20P-M03)

*: These dimensions do not include resin protrusion.

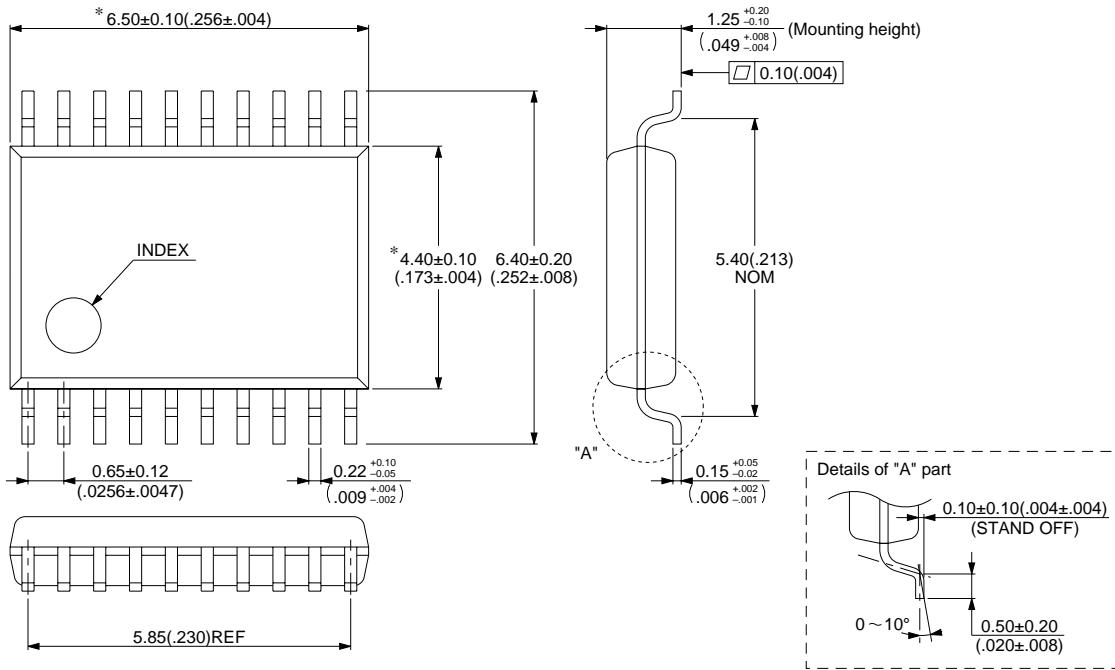

© 1994 FUJITSU LIMITED F20012S-2C-4

Dimensions in mm (inches).

MEMO

FUJITSU MICROELECTRONICS LIMITED

Shinjuku Dai-Ichi Seimei Bldg. 7-1, Nishishinjuku 2-chome, Shinjuku-ku,
Tokyo 163-0722, Japan Tel: +81-3-5322-3347 Fax: +81-3-5322-3387
<http://jp.fujitsu.com/fml/en/>

For further information please contact:

North and South America

FUJITSU MICROELECTRONICS AMERICA, INC.
1250 E. Arques Avenue, M/S 333
Sunnyvale, CA 94085-5401, U.S.A.
Tel: +1-408-737-5600 Fax: +1-408-737-5999
<http://www.fma.fujitsu.com/>

Europe

FUJITSU MICROELECTRONICS EUROPE GmbH
Pittlerstrasse 47, 63225 Langen,
Germany
Tel: +49-6103-690-0 Fax: +49-6103-690-122
<http://emea.fujitsu.com/microelectronics/>

Korea

FUJITSU MICROELECTRONICS KOREA LTD.
206 KOSMO TOWER, 1002 Daechi-Dong,
Kangnam-Gu, Seoul 135-280
Korea
Tel: +82-2-3484-7100 Fax: +82-2-3484-7111
<http://www.fmk.fujitsu.com/>

Asia Pacific

FUJITSU MICROELECTRONICS ASIA PTE LTD.
151 Lorong Chuan, #05-08 New Tech Park,
Singapore 556741
Tel: +65-6281-0770 Fax: +65-6281-0220
<http://www.fujitsu.com/sg/services/micro/semiconductor/>

FUJITSU MICROELECTRONICS SHANGHAI CO., LTD.
Rm.3102, Bund Center, No.222 Yan An Road(E),
Shanghai 200002, China
Tel: +86-21-6335-1560 Fax: +86-21-6335-1605
<http://cn.fujitsu.com/fmc/>

FUJITSU MICROELECTRONICS PACIFIC ASIA LTD.
10/F., World Commerce Centre, 11 Canton Road
Tsimshatsui, Kowloon
Hong Kong
Tel: +852-2377-0226 Fax: +852-2376-3269
<http://cn.fujitsu.com/fmc/tw>

All Rights Reserved.

The contents of this document are subject to change without notice.

Customers are advised to consult with sales representatives before ordering.

The information, such as descriptions of function and application circuit examples, in this document are presented solely for the purpose of reference to show examples of operations and uses of FUJITSU MICROELECTRONICS device; FUJITSU MICROELECTRONICS does not warrant proper operation of the device with respect to use based on such information. When you develop equipment incorporating the device based on such information, you must assume any responsibility arising out of such use of the information.

FUJITSU MICROELECTRONICS assumes no liability for any damages whatsoever arising out of the use of the information.

Any information in this document, including descriptions of function and schematic diagrams, shall not be construed as license of the use or exercise of any intellectual property right, such as patent right or copyright, or any other right of FUJITSU MICROELECTRONICS or any third party or does FUJITSU MICROELECTRONICS warrant non-infringement of any third-party's intellectual property right or other right by using such information. FUJITSU MICROELECTRONICS assumes no liability for any infringement of the intellectual property rights or other rights of third parties which would result from the use of information contained herein.

The products described in this document are designed, developed and manufactured as contemplated for general use, including without limitation, ordinary industrial use, general office use, personal use, and household use, but are not designed, developed and manufactured as contemplated (1) for use accompanying fatal risks or dangers that, unless extremely high safety is secured, could have a serious effect to the public, and could lead directly to death, personal injury, severe physical damage or other loss (i.e., nuclear reaction control in nuclear facility, aircraft flight control, air traffic control, mass transport control, medical life support system, missile launch control in weapon system), or (2) for use requiring extremely high reliability (i.e., submersible repeater and artificial satellite).

Please note that FUJITSU MICROELECTRONICS will not be liable against you and/or any third party for any claims or damages arising in connection with above-mentioned uses of the products.

Any semiconductor devices have an inherent chance of failure. You must protect against injury, damage or loss from such failures by incorporating safety design measures into your facility and equipment such as redundancy, fire protection, and prevention of over-current levels and other abnormal operating conditions.

Exportation/release of any products described in this document may require necessary procedures in accordance with the regulations of the Foreign Exchange and Foreign Trade Control Law of Japan and/or US export control laws.

The company names and brand names herein are the trademarks or registered trademarks of their respective owners.