

ASSP
BIPOLAR

POWER-VOLTAGE MONITORING IC WITH WATCHDOG TIMER

MB3793-28A

■ DESCRIPTION

The MB3793 is an integrated circuit to monitor power voltage; it incorporates a watchdog timer. A reset signal is output when the power is cut or falls abruptly. When the power recovers normally after resetting, a power-on reset signal is output to microprocessor units (MPUs). An internal watchdog timer with two inputs for system operation diagnosis can provide a fail-safe function for various application systems.

Model No.	Marking Code	Detection voltage
MB3793-28A	3793AR	2.8 V

■ FEATURES

- Precise detection of power voltage fall: $\pm 2.5\%$
- Detection voltage with hysteresis
- Low power dispersion: $I_{CC} = 41 \mu\text{A}$ (Typ)
- Internal dual-input watchdog timer
- Watchdog timer halt function
- Independently-set watchdog and reset times

■ APPLICATION

- Arcade Amusement etc.

MB3793-28A

■ PIN ASSIGNMENT

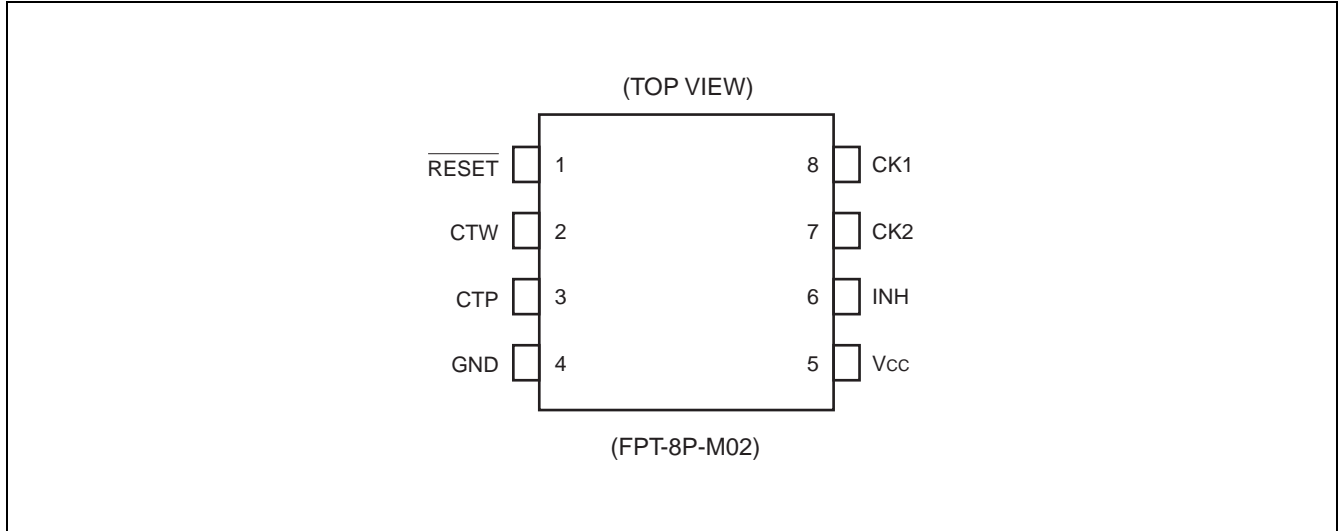

■ PIN DESCRIPTION

Pin No.	Symbol	Description
1	$\overline{\text{RESET}}$	Outputs reset pin
2	CTW	Sets watchdog timer monitoring time pin
3	CTP	Sets power-on reset hold time pin
4	GND	Ground pin
5	Vcc	Power supply pin
6	INH	This pin forces the watchdog timer on/off. When this pin is High level, the watchdog timer is stopped.
7	CK2	Inputs clock 2 pin
8	CK1	Inputs clock 1 pin

■ BLOCK DIAGRAM

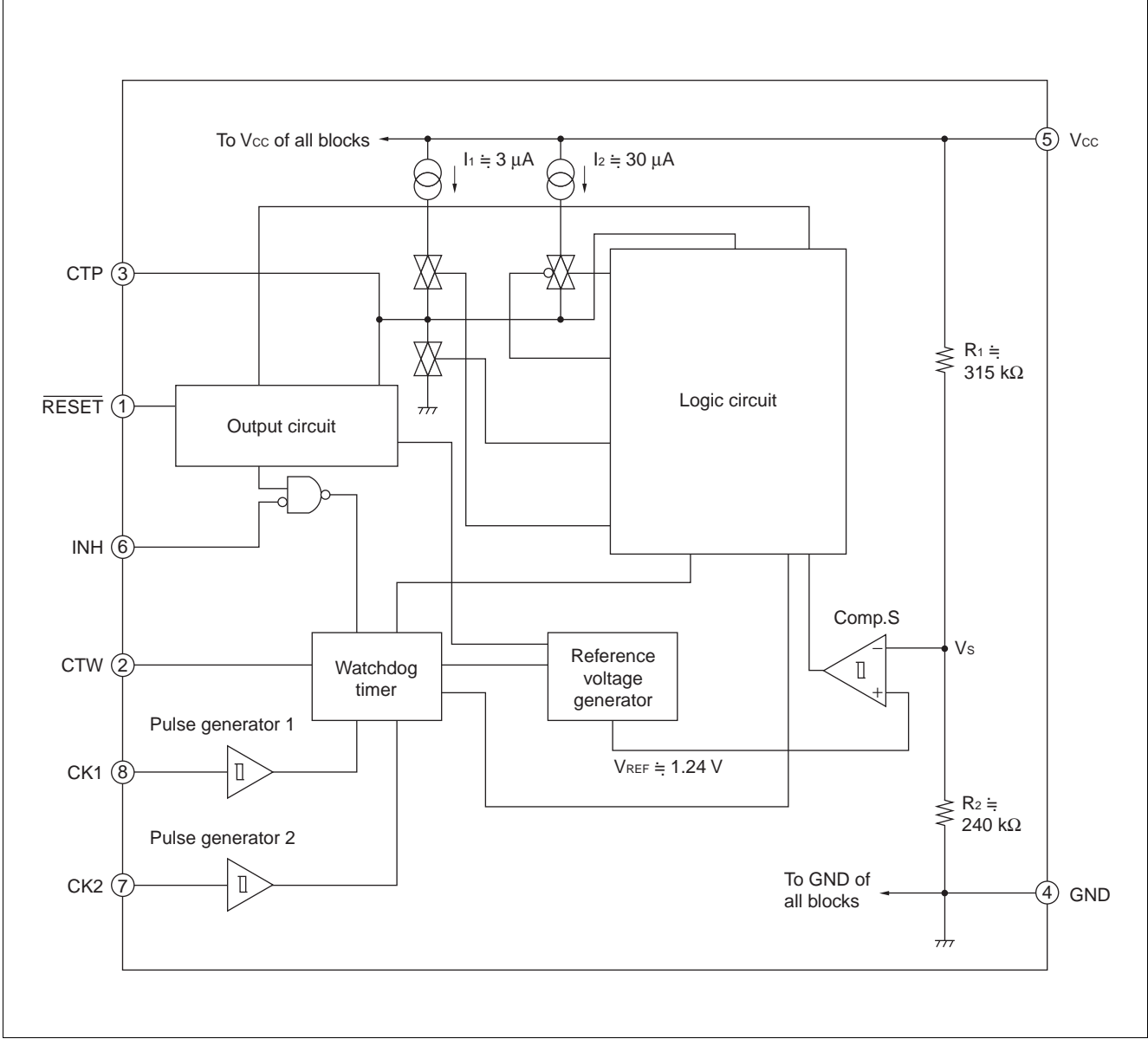

■ BLOCK FUNCTIONS

1. Comp. S

Comp. S is a comparator with hysteresis to compare the reference voltage with a voltage (V_S) that is the result of dividing the power voltage (V_{CC}) by resistors R_1 and R_2 . When V_S falls below 1.24 V, a reset signal is output. This function enables the MB3793 to detect an abnormality within 1 μ s when the power is cut or falls abruptly.

2. Output circuit

The output circuit has a comparator to control the reset signal ($\overline{\text{RESET}}$) output. When the voltage at the CTP pin for setting the power-on reset hold time exceeds the threshold voltage, resetting is canceled.

Since the reset ($\overline{\text{RESET}}$) output buffer has the CMOS organization, no pull-up resistor is needed.

3. Pulse generator

The pulse generator generates pulses when the voltage at the CK1 and CK2 input clock pins changes from Low level to High level (positive-edge trigger) and exceeds the threshold voltage; it sends the clock signal to the watchdog timer.

4. Watchdog timer

The watchdog timer can monitor two clock pulses. Short-circuit the CK1 and CK2 clock pins to monitor a single clock pulse.

5. Logic circuit

Logic circuit controls charging and discharging of the power-on reset hold time setting capacity (C_{TP}) on a signal of Comp.S and Watchdog timer.

■ ABSOLUTE MAXIMUM RATINGS

Parameter	Symbol	Conditions	Rating		Unit
			Min	Max	
Power supply voltage*	V _{CC}	—	-0.3	+7	V
Input voltage*	CK1	V _{CK1}	-0.3	V _{CC} + 0.3 (≤ +7)	V
	CK2	V _{CK2}			
	INH	V _{INH}			
Reset output voltage*	$\overline{\text{RESET}}$	V _{OL}	-0.3	V _{CC} + 0.3 (≤ +7)	V
		V _{OH}			
Reset output current		I _{OL} I _{OH}	-10	+10	mA
Power dissipation	P _D	T _a ≤ +85 °C	—	200	mW
Storage temperature	T _{stg}	—	-55	+125	°C

* : The voltage is based on the ground voltage (0 V).

WARNING: Semiconductor devices can be permanently damaged by application of stress (voltage, current, temperature, etc.) in excess of absolute maximum ratings. Do not exceed these ratings.

■ RECOMMENDED OPERATING CONDITIONS

Parameter	Symbol	Conditions	Value			Unit
			Min	Typ	Max	
Power supply voltage	V _{CC}	—	1.2	3.3	4.0	V
Reset ($\overline{\text{RESET}}$) output current	I _{OL}	—	0	—	+ 5	mA
	I _{OH}	—	-5	—	0	
Power-on reset hold time setting capacity	C _{TP}	—	0.001	0.1	10	μF
Watchdog-timer monitoring time setting capacity*	C _{TW}	—	0.001	0.01	1	μF
Operating ambient temperature	T _a	—	-40	+25	+85	°C

* : The watchdog timer monitor time range depends on the rating of the setting capacitor.

WARNING: The recommended operating conditions are required in order to ensure the normal operation of the semiconductor device. All of the device's electrical characteristics are warranted when the device is operated within these ranges.

Always use semiconductor devices within their recommended operating condition ranges. Operation outside these ranges may adversely affect reliability and could result in device failure.

No warranty is made with respect to uses, operating conditions, or combinations not represented on the data sheet. Users considering application outside the listed conditions are advised to contact their representatives beforehand.

■ ELECTRICAL CHARACTERISTICS

1. DC Characteristics

($V_{CC} = +3.3\text{ V}$, $T_a = +25^\circ\text{C}$)

Parameter	Symbol	Conditions	Value			Unit	
			Min	Typ	Max		
Power current	I_{CC1}	After exit from reset	—	41	55	μA	
Detection voltage	V_{SL}	V _{CC} falling	$T_a = +25^\circ\text{C}$	2.73	2.80	2.87	V
			$T_a = -40\text{ to }+85^\circ\text{C}$	2.69*	2.80	2.91*	
	V_{SH}	V _{CC} rising	$T_a = +25^\circ\text{C}$	2.80	2.87	2.94	V
			$T_a = -40\text{ to }+85^\circ\text{C}$	2.76*	2.87	2.98*	
Detection voltage hysteresis difference	V_{SHYS}	$V_{SH} - V_{SL}$	25	70	100	mV	
CK input threshold voltage	V_{CIH}	—	0.7*	1.3	1.9	V	
	V_{CIL}	—	0.5	1.0	1.5*	V	
CK input hysteresis	V_{CHYS}	—	0.1*	0.3	0.6*	V	
INH input voltage	V_{IIH}	—	2.2	—	V_{CC}	V	
	V_{IIL}	—	0	—	0.8	V	
Input current (CK1,CK2,INH)	I_{IH}	$V_{IH} = V_{CC}$	—	0	1.0	μA	
	I_{IL}	$V_{IL} = 0\text{ V}$	-1.0	0	—	μA	
Reset output voltage	V_{OH}	$I_{RESET} = -3\text{ mA}$	2.8	3.1	—	V	
	V_{OL}	$I_{RESET} = +3\text{ mA}$	—	0.12	0.4	V	
Reset-output minimum power voltage	V_{CCL}	$I_{RESET} = +50\ \mu\text{A}$	—	0.8	1.2	V	

* : This parameter is guaranteed by design, which is not supported by a final test.

2. AC Characteristics

($V_{CC} = +3.3\text{ V}$, $T_a = +25^\circ\text{C}$)

Parameter	Symbol	Conditions	Value			Unit	
			Min	Typ	Max		
Power-on reset hold time	t _{PR}	C _{TP} = 0.1 μF	30	75	120	ms	
Watchdog timer monitoring time	t _{WD}	C _{TW} = 0.01 μF C _{TP} = 0.1 μF	8	16	24	ms	
Watchdog timer reset time	t _{WR}	C _{TP} = 0.1 μF	2	5.5	9	ms	
CK input pulse width	t _{CKW}	—	500	—	—	ns	
CK input pulse cycle	t _{CKT}	—	20	—	—	μs	
Reset ($\overline{\text{RESET}}$) output transition time	Rising	tr*	CL = 50 pF	—	—	500	ns
	Falling	tf*	CL = 50 pF	—	—	500	ns

*: The voltage range is 10% to 90% at testing the reset output transition time.

■ TIMING DIAGRAM

1. Basic operation (Positive clock pulse)

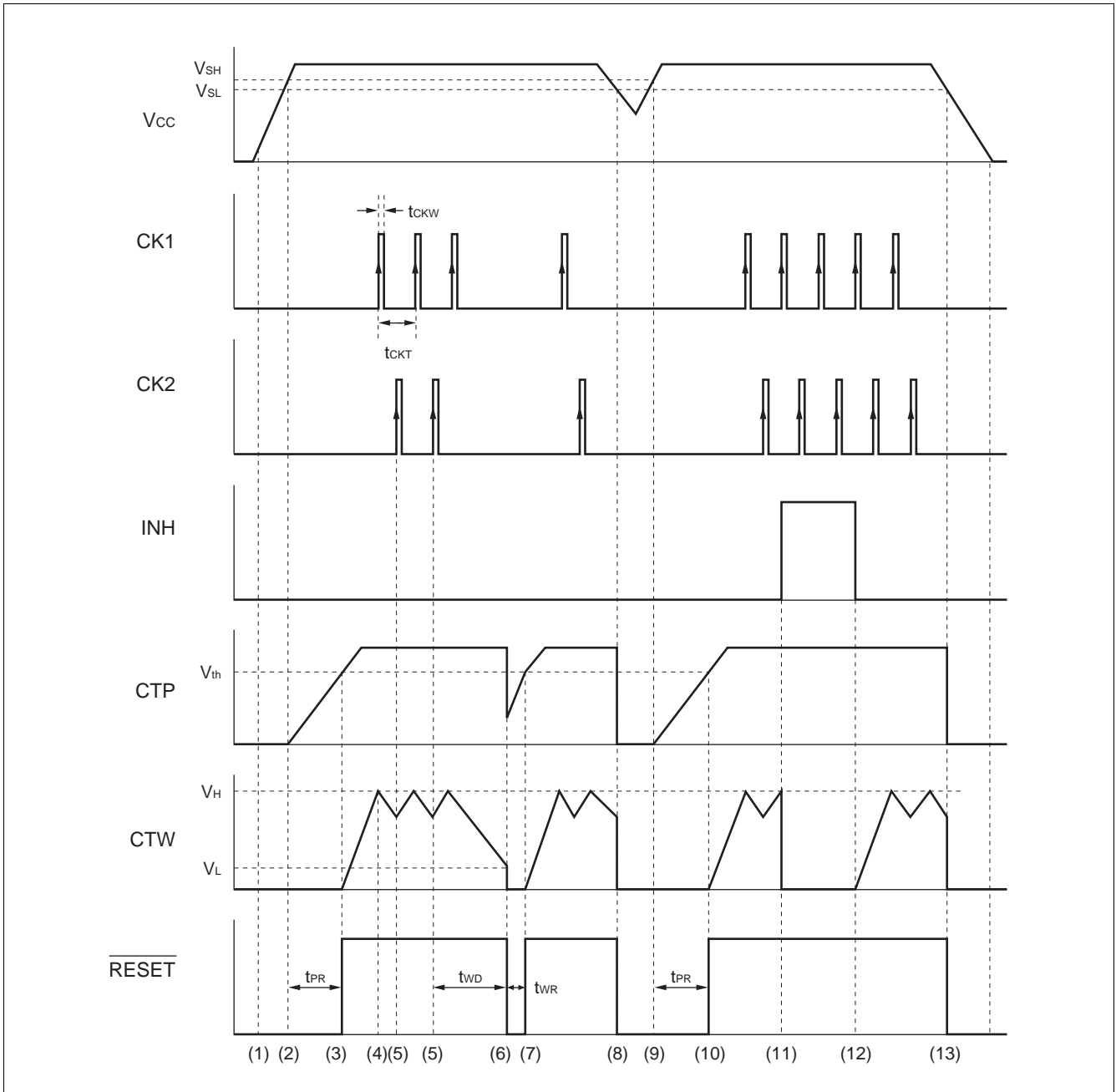

2. Basic operation (Negative clock pulse)

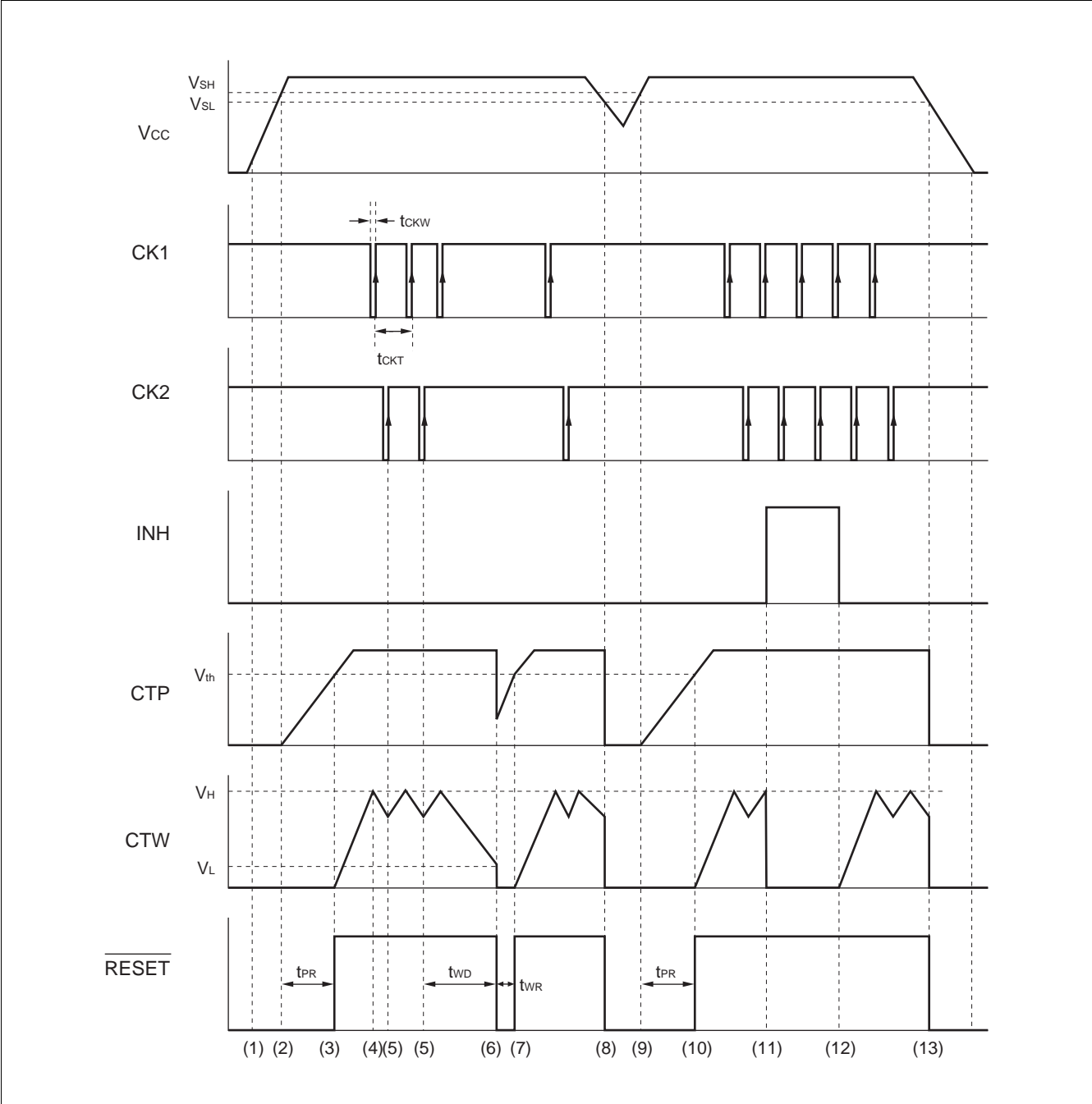

3. Single-clock input monitoring (Positive clock pulse)

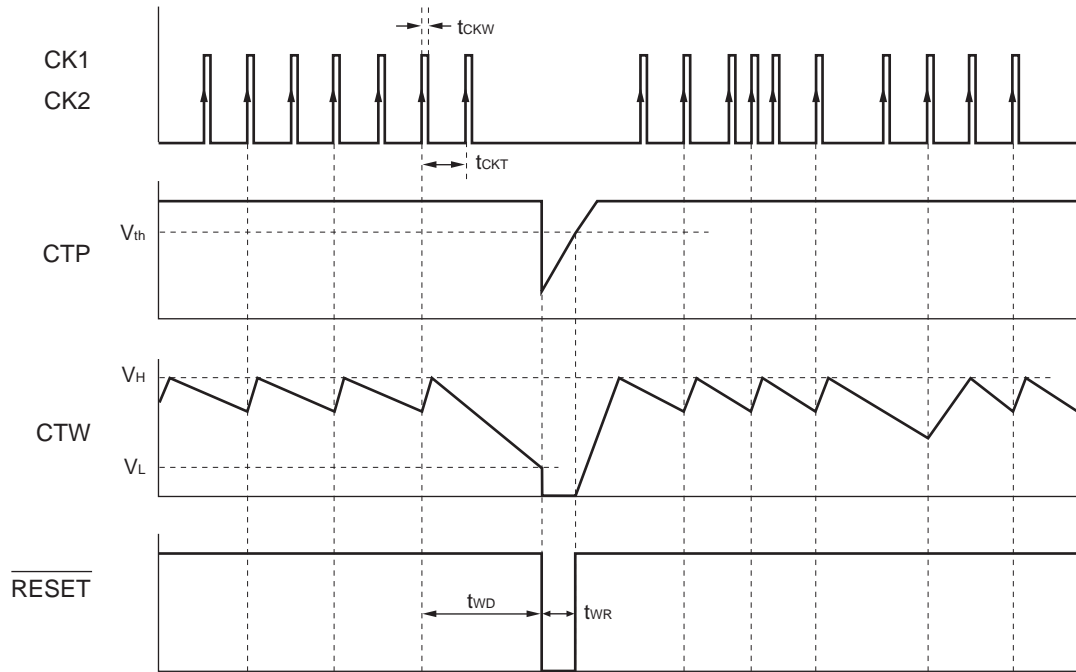

Note : The MB3793 can monitor only one clock.
 The MB3793 checks the clock signal at every other input pulse.
 Therefore, set watchdog timer monitor time t_{WD} to the time that allows the MB3793 to monitor the period twice as long as the input clock pulse.

4. Inhibition operation (Positive clock pulse)

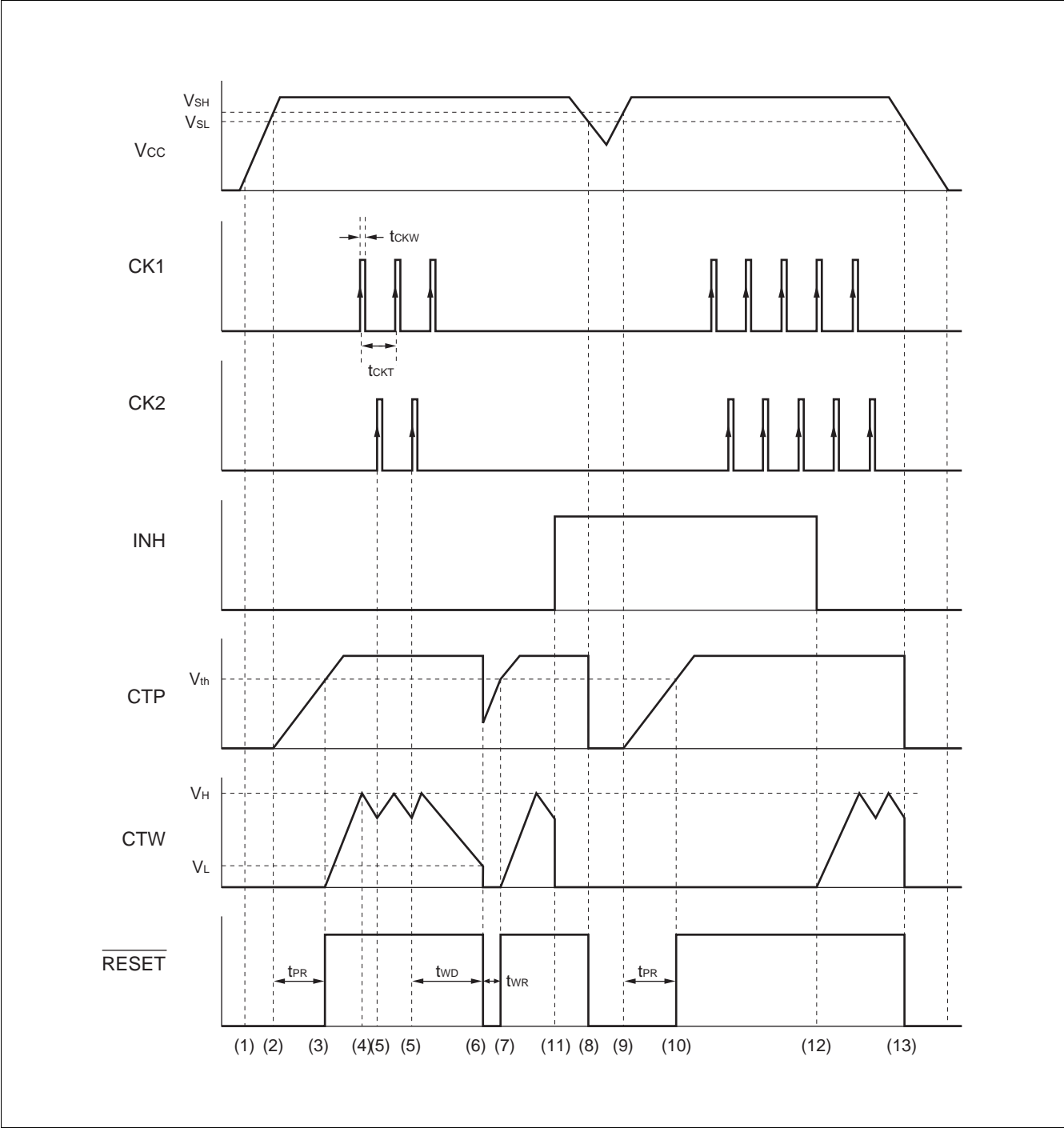

5. Clock pulse input supplementation (Positive clock pulse)

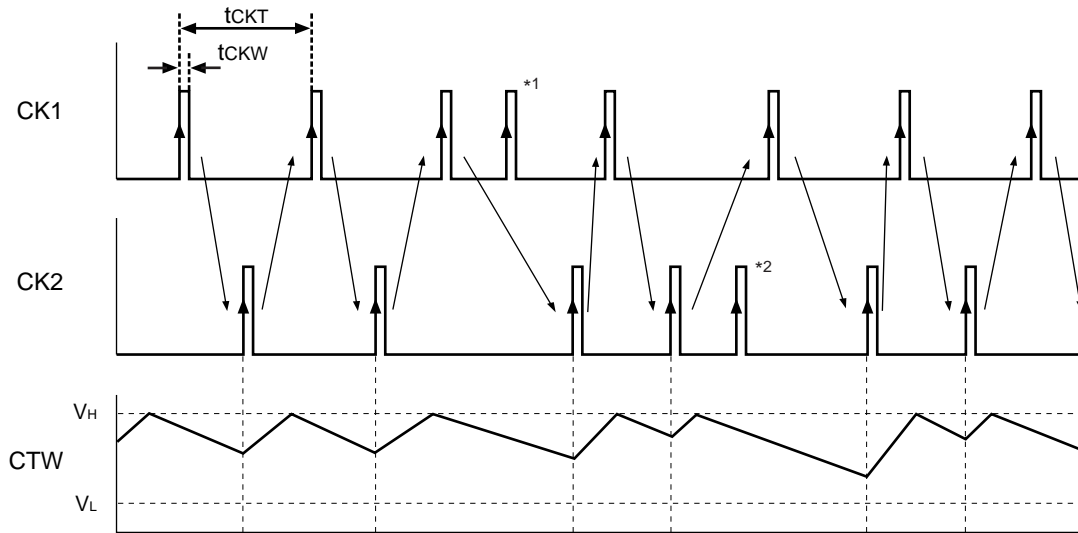

Note : The MB3793 watchdog timer monitors Clock1 (CK1) and Clock2 (CK2) pulses alternately. When a CK2 pulse is detected after detecting a CK1 pulse, the monitoring time setting capacity (C_{TW}) switches to charging from discharging. When two consecutive pulses occur on one side of this alternation before switching, the second pulse is ignored. In the above figure, pulse *1 and *2 are ignored.

■ OPERATION SEQUENCE

1. Positive clock pulse input

Refer to “1. Basic operation (positive clock pulse)” under “■ TIMING DIAGRAM”.

2. Negative clock pulse input

Refer to “2. Basic operation (negative clock pulse)” under “■ TIMING DIAGRAM”.

The MB3793 operates in the same way whether it inputs positive or negative pulses.

3. Single-clock input monitoring

To use the MB3793 while monitoring only one clock, connect clock pins CK1 and CK2.

Although the MB3793 operates basically in the same way as when monitoring two clocks, it monitors the clock signal at every other input pulse.

Refer to “3. Single-clock input monitoring (positive clock pulse)” under “■ TIMING DIAGRAM”.

4. Description of Operations

The numbers given to the following items correspond to numbers (1) to (13) used in “■ TIMING DIAGRAM”.

- (1) The MB3793 outputs a reset signal when the supply voltage (V_{CC}) reaches about 0.8 V (V_{CCL})
- (2) If V_{CC} reaches or exceeds the rise-time detected voltage V_{SH} , the MB3793 starts charging the power-on reset hold time setting capacitor C_{TP} . At this time, the output remains in a reset state. The V_{SH} value is 2.87 V (Typ) .
- (3) When C_{TP} has been charged for a certain period of time T_{PR} (until the CTP pin voltage exceeds the threshold voltage (V_{th}) after the start of charging), the MB3793 cancels the reset (setting the \overline{RESET} pin to “H” level from “L” level).
The V_{th} value is about 2.4 V with $V_{CC} = 3.3$ V

The power-on reset hold time t_{PR} is set with the following equation:

$$t_{PR} \text{ (ms)} \cong A \times C_{TP} \text{ (}\mu\text{F)}$$

The value of A is about 750 with $V_{CC} = 3.3$ V and about 700 with $V_{CC} = 3.0$ V. The MB3793 also starts charging the watchdog timer monitor time setting capacitor (C_{TW}).

- (4) When the voltage at the watchdog timer monitor time setting pin C_{TW} reaches the “H” level threshold voltage V_H , the C_{TW} switches from the charge state to the discharge state.
The value of V_H is always about 1.24 V regardless of the detected voltage.
- (5) If the CK2 pin inputs a clock pulse (positive edge trigger) when the C_{TW} is being discharged in the CK1-CK2 order or simultaneously, the C_{TW} switches from the discharge state to the charge state.
The MB3793 repeats operations (4) and (5) as long as the CK1/CK2 pin inputs clock pulses with the system logic circuit operating normally.
- (6) If no clock pulse is fed to the CK1 or CK2 pin within the watchdog timer monitor time t_{WD} due to some problem with the system logic circuit, the C_{TW} pin is set to the “L” level threshold voltage V_L or less and the MB3793 outputs a reset signal (setting the \overline{RESET} pin to “L” level from “H” level).
The value of V_L is always about 0.24 V regardless of the detected voltage.
The watchdog timer monitor time t_{WD} is set with the following equation:

$$t_{WD} \text{ (ms)} \cong B \times C_{TW} \text{ (}\mu\text{F)} + C \times C_{TP} \text{ (}\mu\text{F)}$$

The value of B is hardly affected by the power supply voltage; it is about 1600 with $V_{CC} = 3.0$ V to 3.3 V. The value of C is 0.

For this reason:

$$t_{WD} \text{ (ms)} \cong B \times C_{TW} \text{ (}\mu\text{F)}$$

- (7) When a certain period of time t_{WR} has passed (until the CTP pin voltage reaches or exceeds V_{th} again after recharging the C_{TP}), the MB3793 cancels the reset signal and starts operating the watchdog timer. The watchdog timer monitor reset time t_{WR} is set with the following equation:
 $t_{WR} \text{ (ms)} \cong D \times C_{TP} \text{ (}\mu\text{F)}$
 The value of D is 55 with $V_{CC} = 3.3 \text{ V}$ and about 50 with $V_{CC} = 3.0 \text{ V}$.
 The MB3793 repeats operations (4) and (5) as long as the CK1/CK2 pin inputs clock pulses. If no clock pulse is input, the MB3793 repeats operations (6) and (7).
- (8) If V_{CC} is lowered to the fall-time detected voltage (V_{SL}) or less, the CTP pin voltage decreases and the MB3793 outputs a reset signal (setting the $\overline{\text{RESET}}$ pin to "L" level from "H" level).
 The value of V_{SL} is 2.80 V (Typ) .
- (9) When V_{CC} reaches or exceeds V_{SH} again, the MB3793 starts charging the C_{TP} .
- (10) When the CTP pin voltage reaches or exceeds V_{th} , the MB3793 cancels the reset and restarts operating the watchdog timer. It repeats operations (4) and (5) as long as the CK1/CK2 pin inputs clock pulses.
- (11) Making the inhibit pin active (setting the INH pin to "H" from "L") forces the watchdog timer to stop operation.
 This stops only the watchdog timer, leaving the MB3793 monitoring V_{CC} (operations (8) to (10)).
 The watchdog timer remains inactive unless the inhibit input is canceled.
 The inhibition (INH) pin must be connecting a voltage of more low impedance, to evade of the noise.
- (12) Canceling the inhibit input (setting the INH pin to "L" from "H") restarts the watchdog timer.
- (13) The reset signal is output when the power supply is turned off to set V_{CC} to V_{SL} or less.

1. Equation of time-setting capacitances (C_{TP} and C_{TW}) and set time

$$t_{PR} \text{ [ms]} \cong A \times C_{TP} \text{ [}\mu\text{F]}$$

$$t_{WD} \text{ [ms]} \cong B \times C_{TW} \text{ [}\mu\text{F]} + C \times C_{TP} \text{ [}\mu\text{F]}$$

However, when $C_{TP}/C_{TW} \cong 10$ or less, $t_{WD} \text{ [ms]} \cong B \times C_{TW} \text{ [}\mu\text{F]}$

$$t_{WR} \text{ [ms]} \cong D \times C_{TP} \text{ [}\mu\text{F]}$$

Values of A, B, C, and D

A	B	C	D	Remark
750	1600	0	55	$V_{CC} = 3.3 \text{ V}$
700	1600	0	50	$V_{CC} = 3.0 \text{ V}$

Note: The width of value of t_{PR} , t_{WD} and t_{WR} becomes the same ratio as width (Min, Max) of each specification value.

2. Example (when $C_{TP} = 0.1 \mu\text{F}$ and $C_{TW} = 0.01 \mu\text{F}$)

time (ms)	Symbol	$V_{CC} = 3.3 \text{ V}$	$V_{CC} = 3.0 \text{ V}$
	t_{PR}		75
t_{WD}		16	16
t_{WR}		5.5	5

TYPICAL CHARACTERISTICS

I_{CC} - V_{CC} characteristics

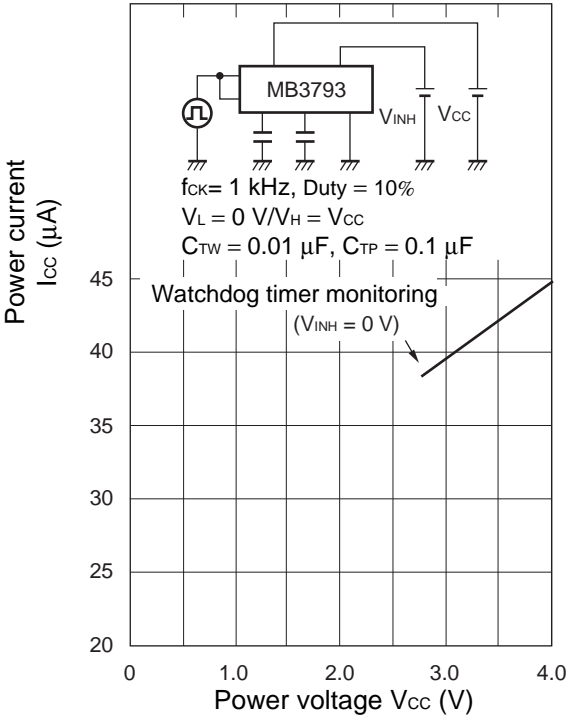

V_{SH}, V_{SL} - T_a characteristics

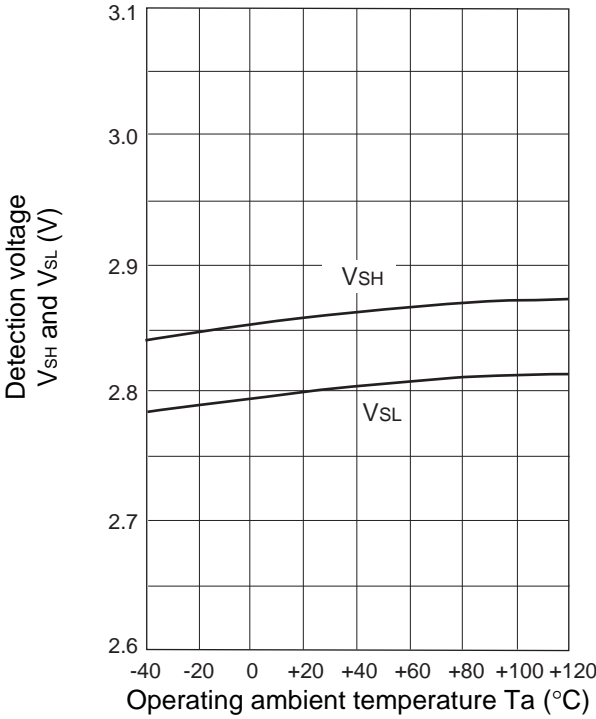

V_{RESET} - I_{RESET} characteristics (P-MOS side)

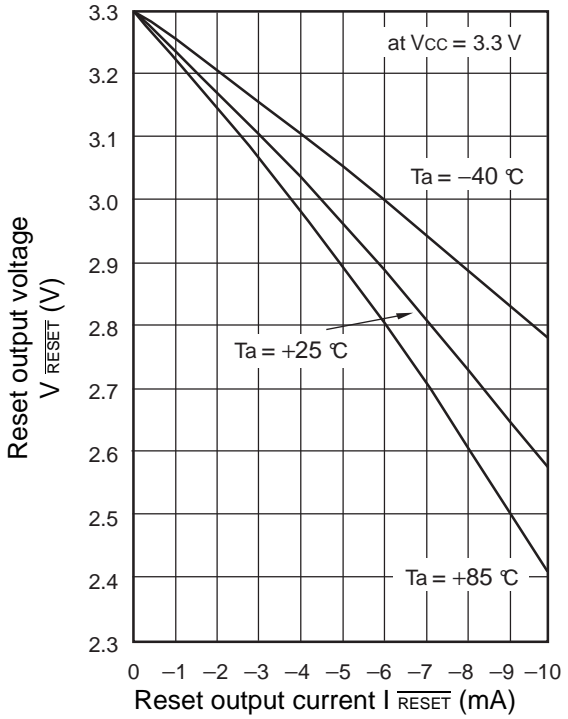

V_{RESET} - I_{RESET} characteristics (N-MOS side)

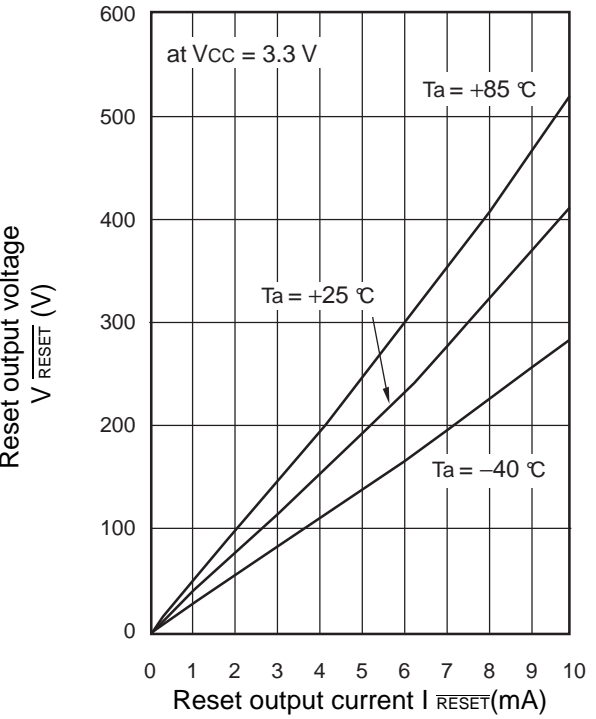

(Continued)

$\overline{V_{RESET}}$ - V_{CC} characteristics

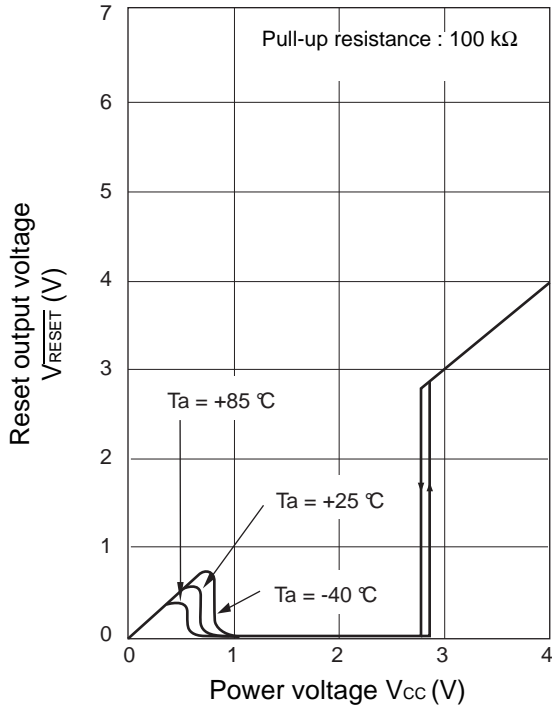

t_{PR} - T_a characteristics

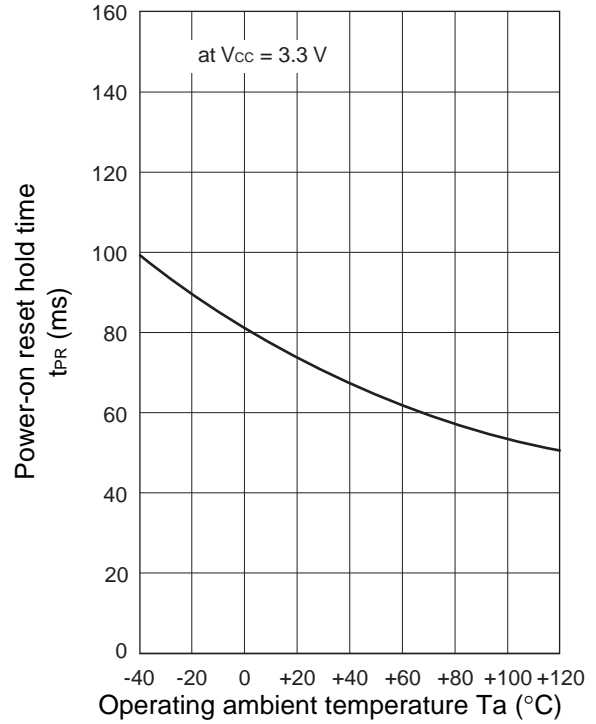

t_{WR} - T_a characteristics

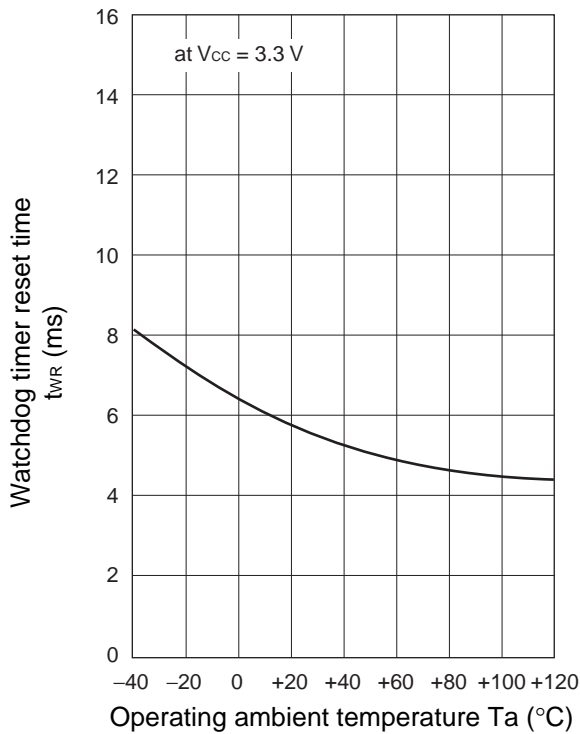

t_{WD} - T_a characteristics

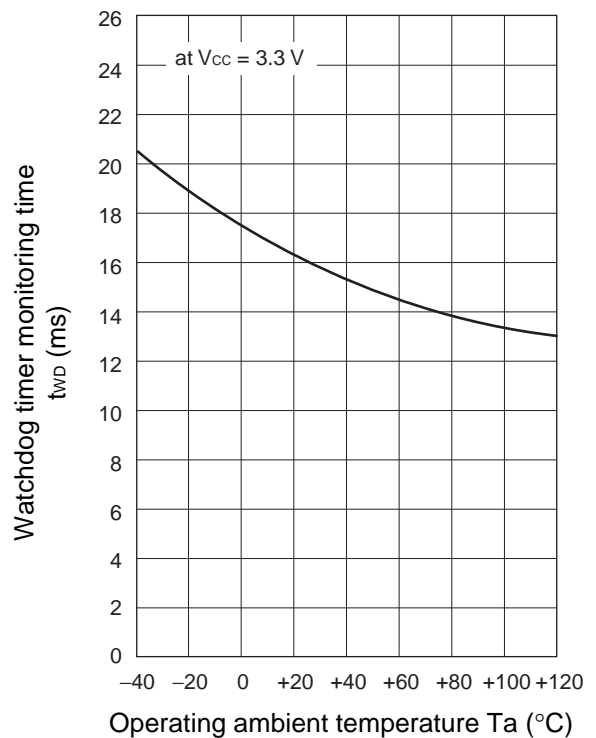

(Continued)

(Continued)

t_{PR} - C_{TP} characteristics

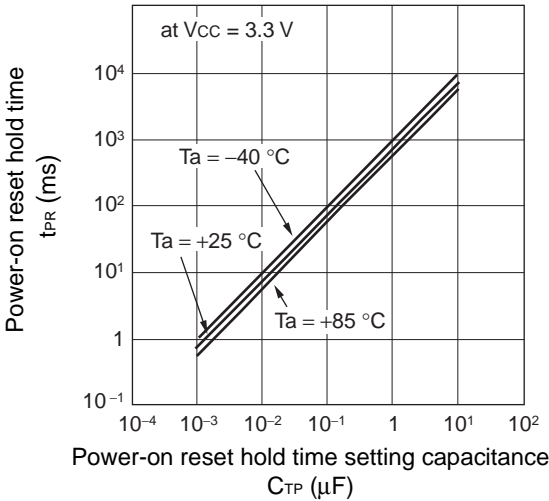

t_{WR} - C_{TP} characteristics

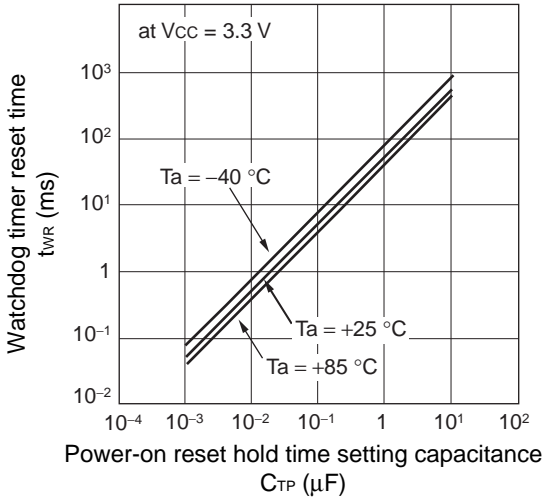

t_{WD} - C_{TW} characteristics

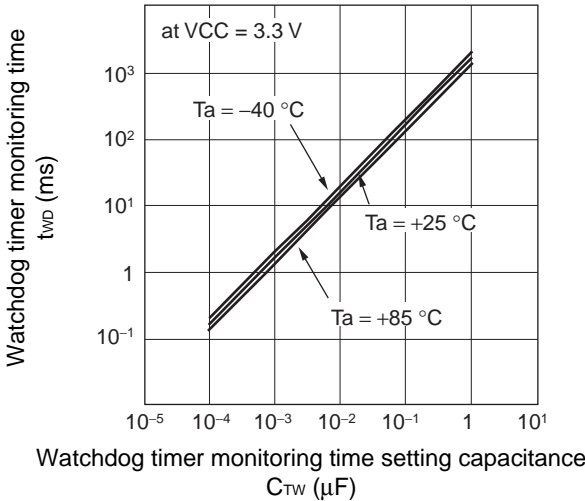

■ APPLICATION EXAMPLE

1. Supply voltage monitor and watchdog timer

(1) 1-clock monitor

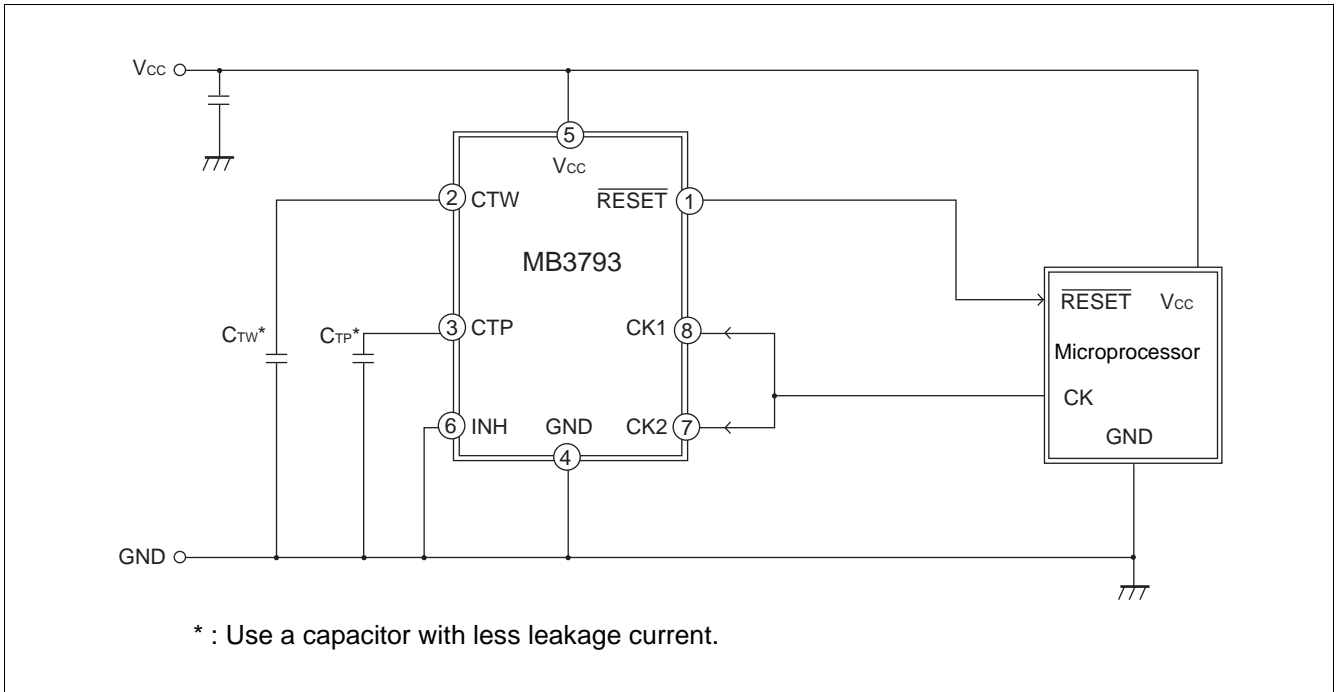

(2) 2-clock monitor

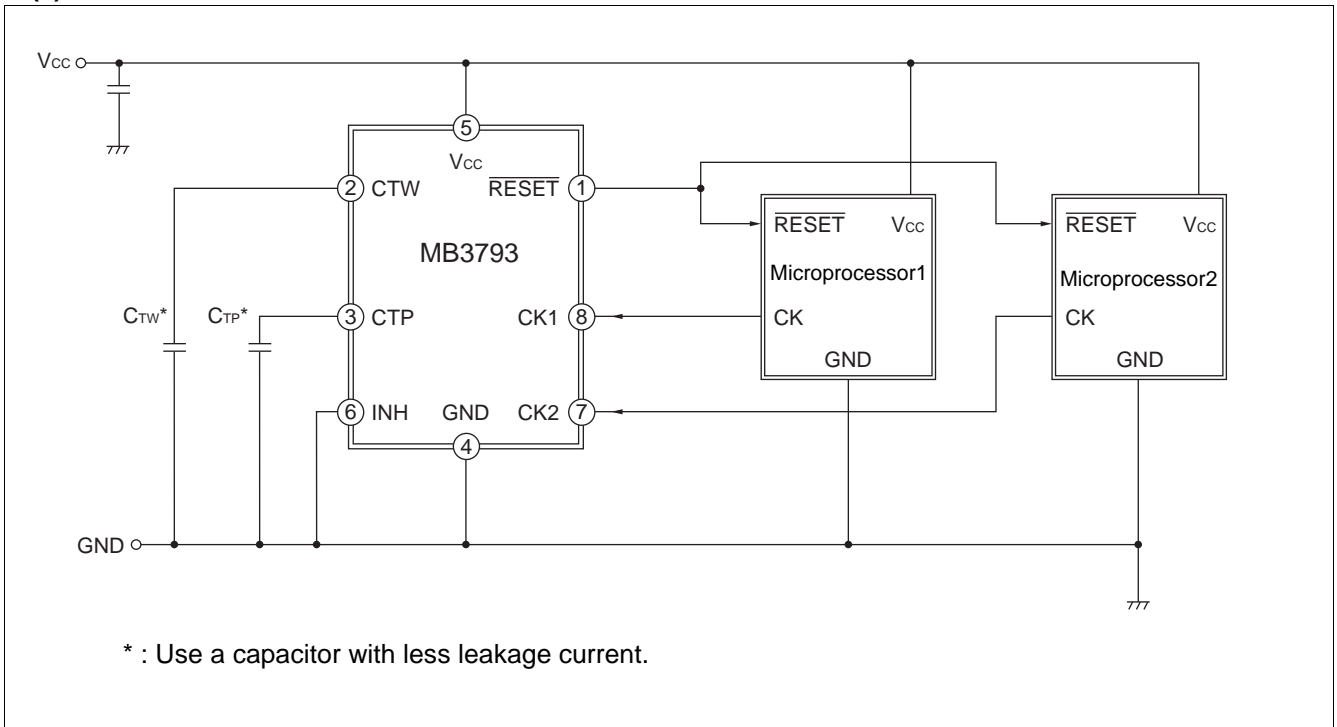

2. Supply voltage monitor and watchdog timer stop

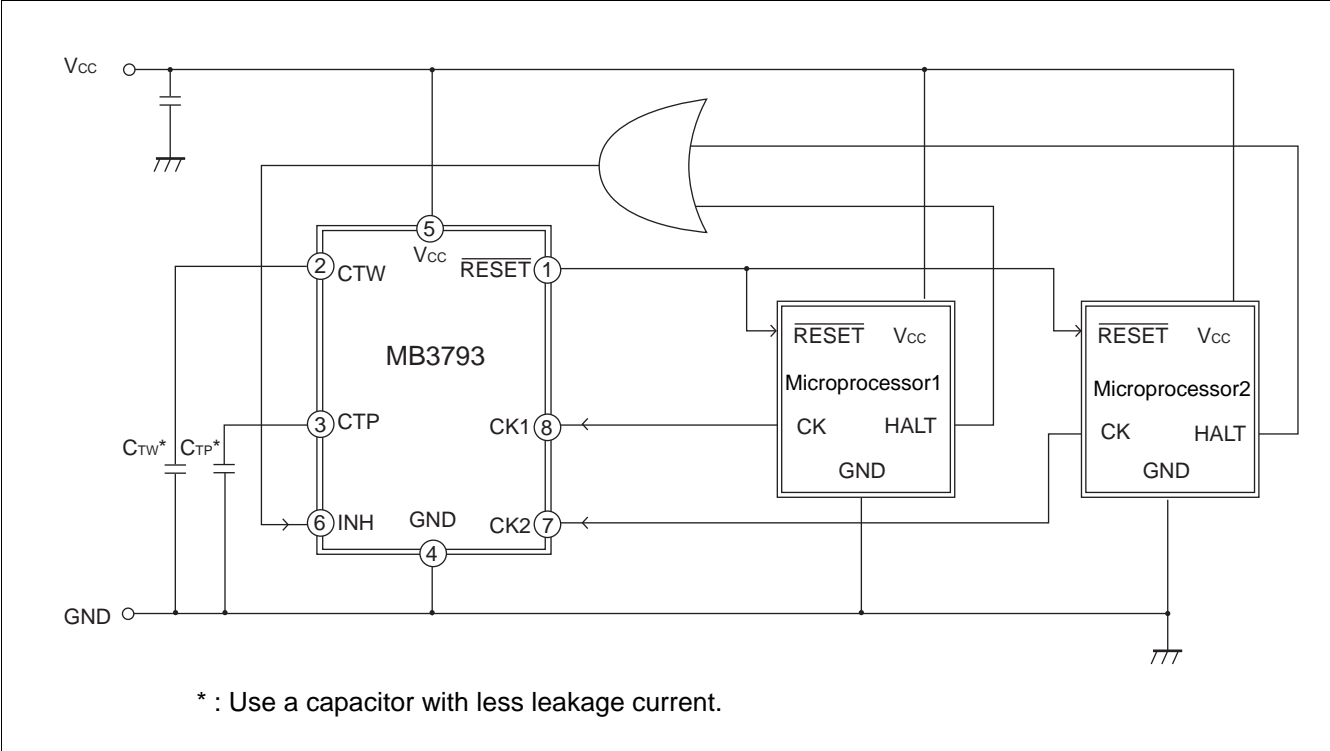

3. Setting of compulsory reset

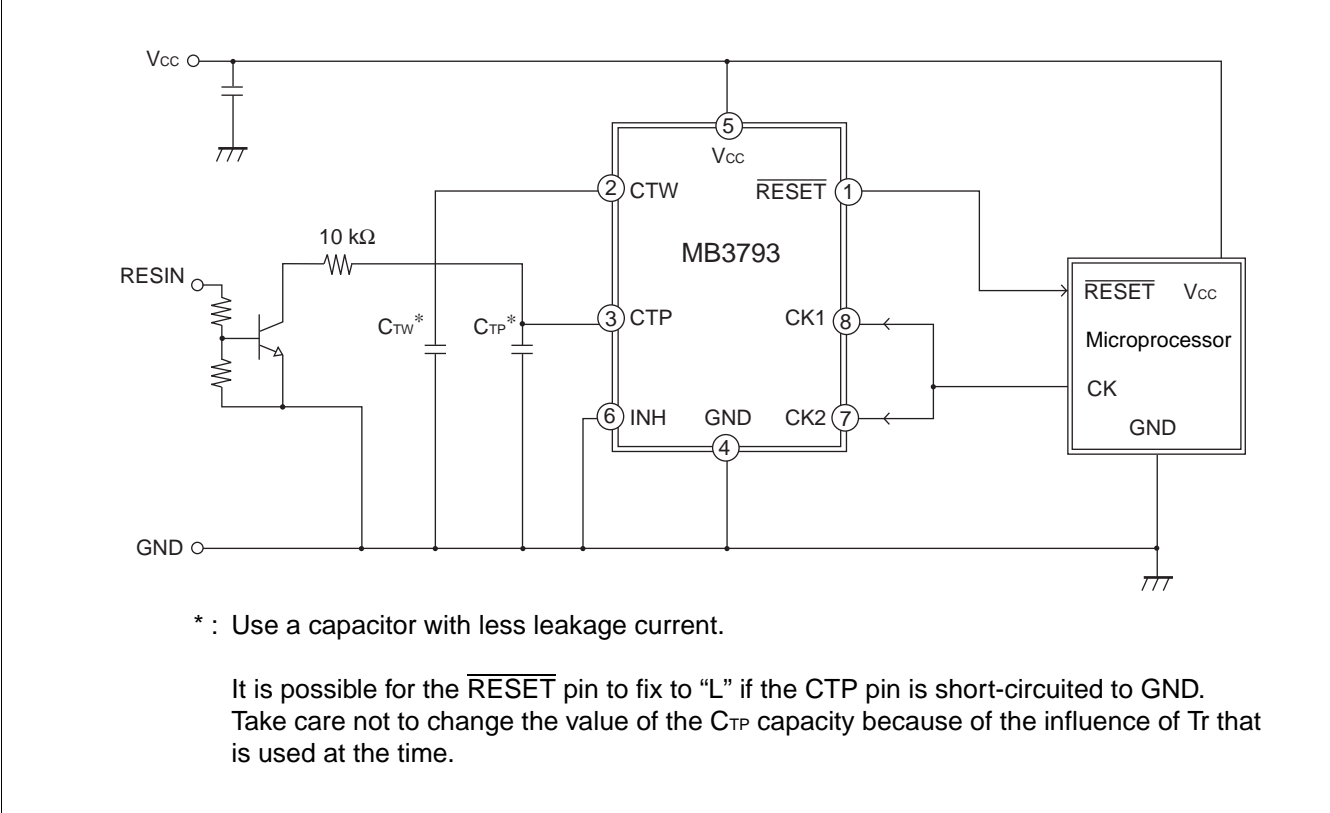

■ USAGE PRECAUTION

1. Do not configure the IC over the maximum ratings

If the IC is used over the maximum ratings, the LSI may be permanently damaged.

It is preferable for the device to normally operate within the recommended usage conditions. Usage outside of these conditions can have a bad effect on the reliability of the LSI.

2. Use the devices within recommended operating conditions

The recommended operating conditions are under which the LSI is guaranteed to operate.

The electrical ratings are guaranteed when the device is used within the recommended operating conditions and under the conditions stated for each item.

3. Printed circuit board ground lines should be set up with consideration for common impedance

4. Take appropriate measures against static electricity

- Containers for semiconductor materials should have anti-static protection or be made of conductive material.
- After mounting, printed circuit boards should be stored and shipped in conductive bags or containers.
- Work platforms, tools, and instruments should be properly grounded.
- Working personnel should be grounded with resistance of 250 k Ω to 1 M Ω between body and ground.

5. Do not apply negative voltages

The use of negative voltages below -0.3 V may create parasitic transistors on LSI lines, which can cause malfunctions.

■ ORDERING INFORMATION

Part number	Package	Remarks
MB3793-28APNF	8-pin plastic SOP (FPT-8P-M02)	

■ RoHS Compliance Information of Lead (Pb) Free version

The LSI products of Fujitsu Microelectronics with “E1” are compliant with RoHS Directive , and has observed the standard of lead, cadmium, mercury, Hexavalent chromium, polybrominated biphenyls (PBB) , and polybrominated diphenyl ethers (PBDE) .

The product that conforms to this standard is added “E1” at the end of the part number.

■ LABELING SAMPLE (Lead free version)

Lead-free mark

JEITA logo JEDEC logo

MB123456P - 789 - GE1
 (3N) 1MB123456P-789-GE1 1000
 (3N)2 1561190005 107210
 1,000 PCS
 MB123456P - 789 - GE1
 2006/03/01 ASSEMBLED IN JAPAN
 MB123456P - 789 - GE1 0605 - Z01A 1000
 1561190005 1/1

QC PASS

The part number of a lead-free product has the trailing characters “E1”.

“ASSEMBLED IN CHINA” is printed on the label of a product assembled in China.

■ MARKING FORMAT (Lead Free version)

Lead Free version

3793AR
 XXXX
 E1 XXX

SOP-8
 (FPT-8P-M02)

■ MB3793-28APNF RECOMMENDED CONDITIONS OF MOISTURE SENSITIVITY LEVEL

Item	Condition	
Mounting Method	IR (infrared reflow) , Manual soldering (partial heating method)	
Mounting times	2 times	
Storage period	Before opening	Please use it within two years after Manufacture.
	From opening to the 2nd reflow	Less than 8 days
	When the storage period after opening was exceeded	Please processes within 8 days after baking (125 °C, 24H)
Storage conditions	5 °C to 30 °C, 70%RH or less (the lowest possible humidity)	

[Temperature Profile for FJ Standard IR Reflow]

(1) IR (infrared reflow)

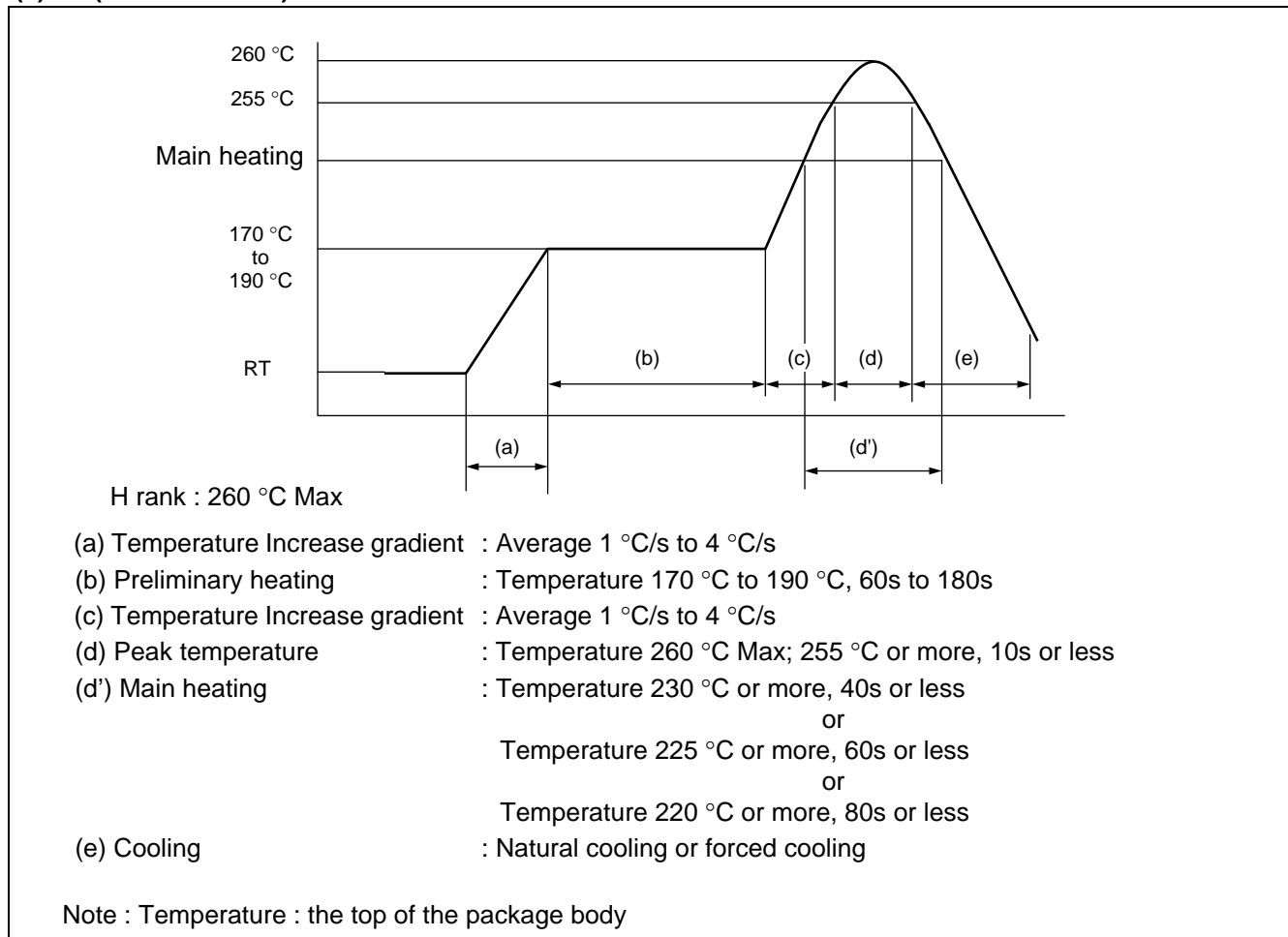

(2) Manual soldering (partial heating method)

Conditions : Temperature 400 °C Max
 Times : 5 s max/pin

MB3793-28A

■ PACKAGE DIMENSIONS

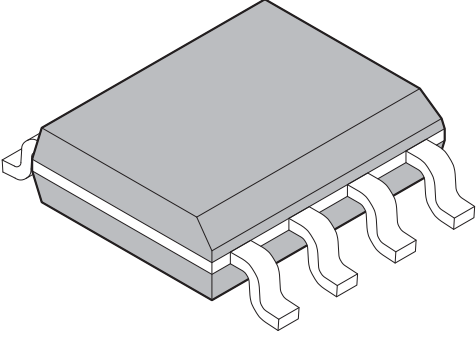
<p style="text-align: center;">8-pin plastic SOP</p>  <p style="text-align: center;">(FPT-8P-M02)</p>	Lead pitch	1.27 mm
	Package width × package length	3.9 × 5.05 mm
	Lead shape	Gullwing
	Sealing method	Plastic mold
	Mounting height	1.75 mm MAX
	Weight	0.06 g

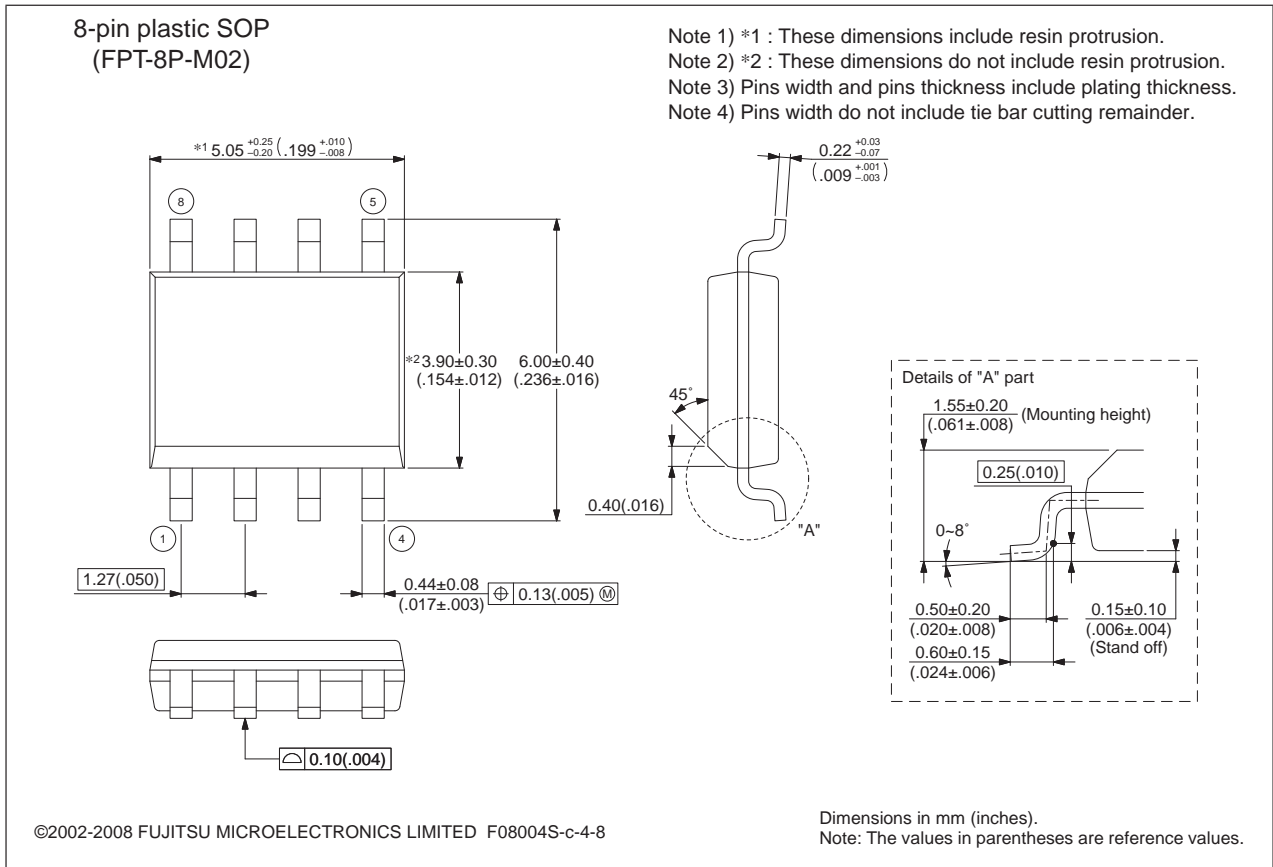

Please check the latest package dimension at the following URL.
<http://edevice.fujitsu.com/package/en-search/>

■ CONTENTS

	page
- DESCRIPTION	1
- FEATURES	1
- APPLICATION	1
- PIN ASSIGNMENT	2
- PIN DESCRIPTION	2
- BLOCK DIAGRAM	3
- BLOCK FUNCTIONS	4
- ABSOLUTE MAXIMUM RATINGS	5
- RECOMMENDED OPERATING CONDITIONS	5
- ELECTRICAL CHARACTERISTICS	6
- TIMING DIAGRAM	8
- OPERATION SEQUENCE	13
- TYPICAL CHARACTERISTICS	15
- APPLICATION EXAMPLE	18
- USAGE PRECAUTION	20
- ORDERING INFORMATION	21
- RoHS Compliance Information of Lead (Pb) Free version	22
- LABELING SAMPLE (Lead free version)	22
- MARKING FORMAT (Lead Free version)	22
- MB3793-28APNF RECOMMENDED CONDITIONS OF MOISTURE SENSITIVITY LEVEL	23
- PACKAGE DIMENSIONS	24

MEMO

MEMO

FUJITSU MICROELECTRONICS LIMITED

Shinjuku Dai-Ichi Seimei Bldg., 7-1, Nishishinjuku 2-chome,
Shinjuku-ku, Tokyo 163-0722, Japan
Tel: +81-3-5322-3329
<http://jp.fujitsu.com/fml/en/>

For further information please contact:

North and South America

FUJITSU MICROELECTRONICS AMERICA, INC.
1250 E. Arques Avenue, M/S 333
Sunnyvale, CA 94085-5401, U.S.A.
Tel: +1-408-737-5600 Fax: +1-408-737-5999
<http://www.fma.fujitsu.com/>

Asia Pacific

FUJITSU MICROELECTRONICS ASIA PTE. LTD.
151 Lorong Chuan,
#05-08 New Tech Park 556741 Singapore
Tel : +65-6281-0770 Fax : +65-6281-0220
<http://www.fmal.fujitsu.com/>

Europe

FUJITSU MICROELECTRONICS EUROPE GmbH
Pittlerstrasse 47, 63225 Langen, Germany
Tel: +49-6103-690-0 Fax: +49-6103-690-122
<http://emea.fujitsu.com/microelectronics/>

FUJITSU MICROELECTRONICS SHANGHAI CO., LTD.

Rm. 3102, Bund Center, No.222 Yan An Road (E),
Shanghai 200002, China
Tel : +86-21-6146-3688 Fax : +86-21-6335-1605
<http://cn.fujitsu.com/fmc/>

Korea

FUJITSU MICROELECTRONICS KOREA LTD.
206 Kosmo Tower Building, 1002 Daechi-Dong,
Gangnam-Gu, Seoul 135-280, Republic of Korea
Tel: +82-2-3484-7100 Fax: +82-2-3484-7111
<http://kr.fujitsu.com/fmk/>

FUJITSU MICROELECTRONICS PACIFIC ASIA LTD.

10/F., World Commerce Centre, 11 Canton Road,
Tsimshatsui, Kowloon, Hong Kong
Tel : +852-2377-0226 Fax : +852-2376-3269
<http://cn.fujitsu.com/fmc/en/>

Specifications are subject to change without notice. For further information please contact each office.

All Rights Reserved.

The contents of this document are subject to change without notice.

Customers are advised to consult with sales representatives before ordering.

The information, such as descriptions of function and application circuit examples, in this document are presented solely for the purpose of reference to show examples of operations and uses of FUJITSU MICROELECTRONICS device; FUJITSU MICROELECTRONICS does not warrant proper operation of the device with respect to use based on such information. When you develop equipment incorporating the device based on such information, you must assume any responsibility arising out of such use of the information.

FUJITSU MICROELECTRONICS assumes no liability for any damages whatsoever arising out of the use of the information.

Any information in this document, including descriptions of function and schematic diagrams, shall not be construed as license of the use or exercise of any intellectual property right, such as patent right or copyright, or any other right of FUJITSU MICROELECTRONICS or any third party or does FUJITSU MICROELECTRONICS warrant non-infringement of any third-party's intellectual property right or other right by using such information. FUJITSU MICROELECTRONICS assumes no liability for any infringement of the intellectual property rights or other rights of third parties which would result from the use of information contained herein.

The products described in this document are designed, developed and manufactured as contemplated for general use, including without limitation, ordinary industrial use, general office use, personal use, and household use, but are not designed, developed and manufactured as contemplated (1) for use accompanying fatal risks or dangers that, unless extremely high safety is secured, could have a serious effect to the public, and could lead directly to death, personal injury, severe physical damage or other loss (i.e., nuclear reaction control in nuclear facility, aircraft flight control, air traffic control, mass transport control, medical life support system, missile launch control in weapon system), or (2) for use requiring extremely high reliability (i.e., submersible repeater and artificial satellite).

Please note that FUJITSU MICROELECTRONICS will not be liable against you and/or any third party for any claims or damages arising in connection with above-mentioned uses of the products.

Any semiconductor devices have an inherent chance of failure. You must protect against injury, damage or loss from such failures by incorporating safety design measures into your facility and equipment such as redundancy, fire protection, and prevention of over-current levels and other abnormal operating conditions.

Exportation/release of any products described in this document may require necessary procedures in accordance with the regulations of the Foreign Exchange and Foreign Trade Control Law of Japan and/or US export control laws.

The company names and brand names herein are the trademarks or registered trademarks of their respective owners.