

ASSP for Power Management Applications *(General-Purpose DC/DC Converter)*

2ch PFM/PWM DC/DC converter IC with synchronous rectification

MB39A136

■ DESCRIPTION

MB39A136 is 2ch step-down DC/DC converter IC of the current mode N-ch/N-ch synchronous rectification method. It contains the enhanced protection features, and supports the symmetrical-phase method and the ceramic capacitor. MB39A136 realizes rapid response, high efficiency, and low ripple voltage, and its high-frequency operation enables the miniaturization of inductors and I/O capacitors.

■ FEATURES

- High efficiency
- For frequency setting by external resistor : 100 kHz to 1 MHz
- Error Amp threshold voltage : 0.7 V \pm 1.0%
- Minimum output voltage value : 0.7 V
- Wide range of power-supply voltage : 4.5 V to 25 V
- PFM/PWM auto switching mode and fixed PWM mode selectable
- Supports Symmetrical-Phase method
- With built-in over voltage protection function
- With built-in under voltage protection function
- With built-in over current protection function
- With built-in over-temperature protection function
- With built-in soft start/stop circuit without load dependence
- With built-in synchronous rectification type output steps for N-ch MOS FET
- Standby current : 0 [μ A] Typ
- Small package : TSSOP-24

■ APPLICATION

- Digital TV
- Photocopiers
- Surveillance cameras
- Set-top boxes (STB)
- DVD players, DVD recorders
- Projectors
- IP phones
- Vending machine
- Consoles and other non-portable devices

■ PIN ASSIGNMENT

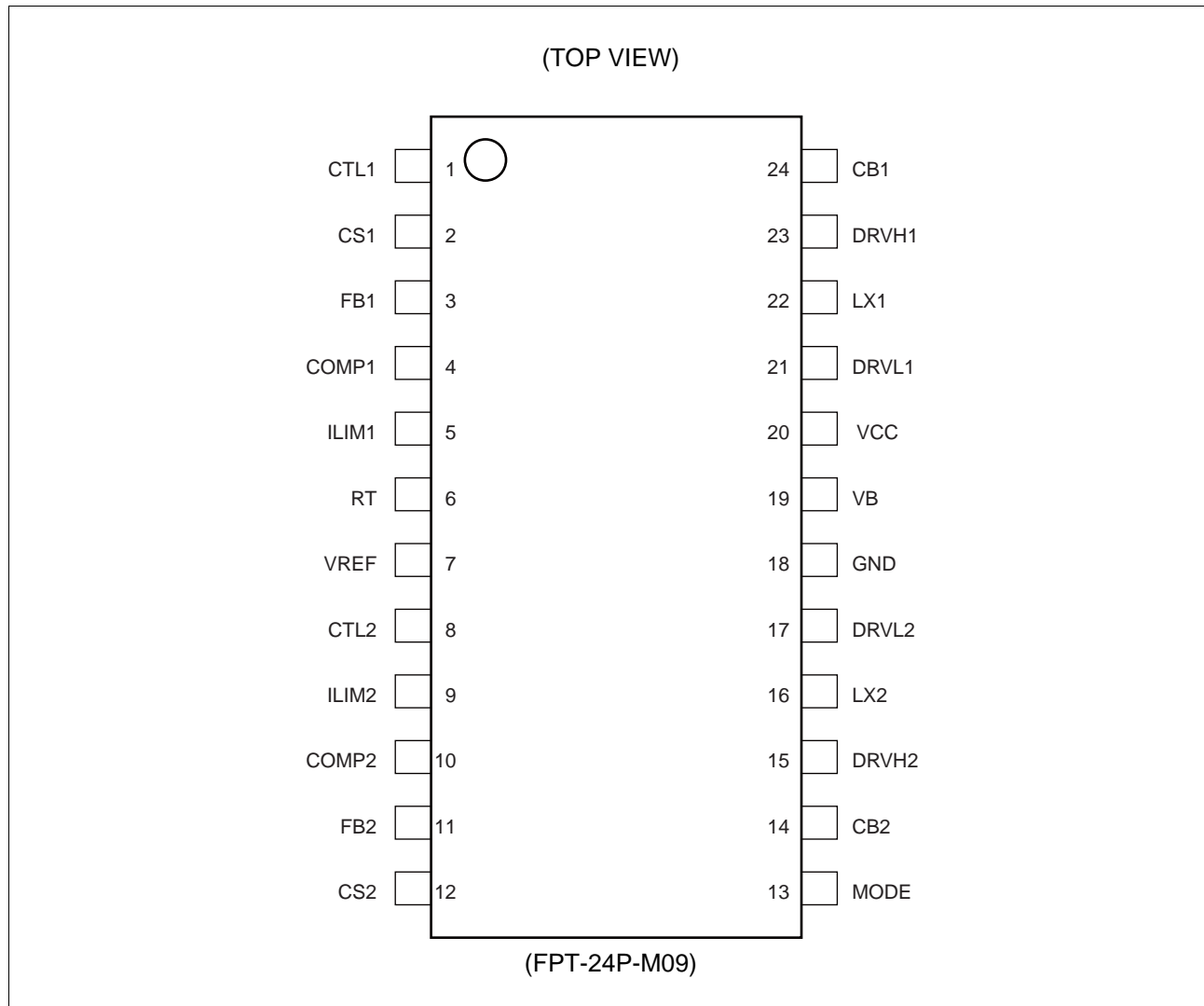

■ PIN DESCRIPTION

Pin No.	Symbol	I/O	Description
1	CTL1	I	CH1 control pin.
2	CS1	I	CH1 soft-start time setting capacitor connection pin.
3	FB1	I	CH1 Error amplifier inverted input pin.
4	COMP1	O	CH1 error amplifier output pin.
5	ILIM1	I	CH1 over current detection level setting voltage input pin.
6	RT	—	Oscillation frequency setting resistor connection pin.
7	VREF	O	Reference voltage output pin.
8	CTL2	I	CH2 control pin.
9	ILIM2	I	CH2 over current detection level setting voltage input pin.
10	COMP2	O	CH2 error amplifier output pin.
11	FB2	I	CH2 Error amplifier inverted input pin.
12	CS2	I	CH2 soft-start time setting capacitor connection pin.
13	MODE	I	PFM/PWM switch pin. (CH1 and CH2 commonness) It becomes fixed PWM operation with the VREF connection, and it becomes PFM/PWM operation with the GND connection.
14	CB2	—	CH2 connection pin for boot strap capacitor.
15	DRVH2	O	CH2 output pin for external high-side FET gate drive.
16	LX2	—	CH2 inductor and external high-side FET source connection pin.
17	DRVL2	O	CH2 output pin for external low-side FET gate drive.
18	GND	—	Ground pin.
19	VB	O	Bias voltage output pin.
20	VCC	—	Power supply pin for reference voltage and control circuit.
21	DRVL1	O	CH1 output pin for external low-side FET gate drive.
22	LX1	—	CH1 inductor and external high-side FET source connection pin.
23	DRVH1	O	CH1 output pin for external high-side FET gate drive.
24	CB1	—	CH1 connection pin for boot strap capacitor.

MB39A136

■ BLOCK DIAGRAM

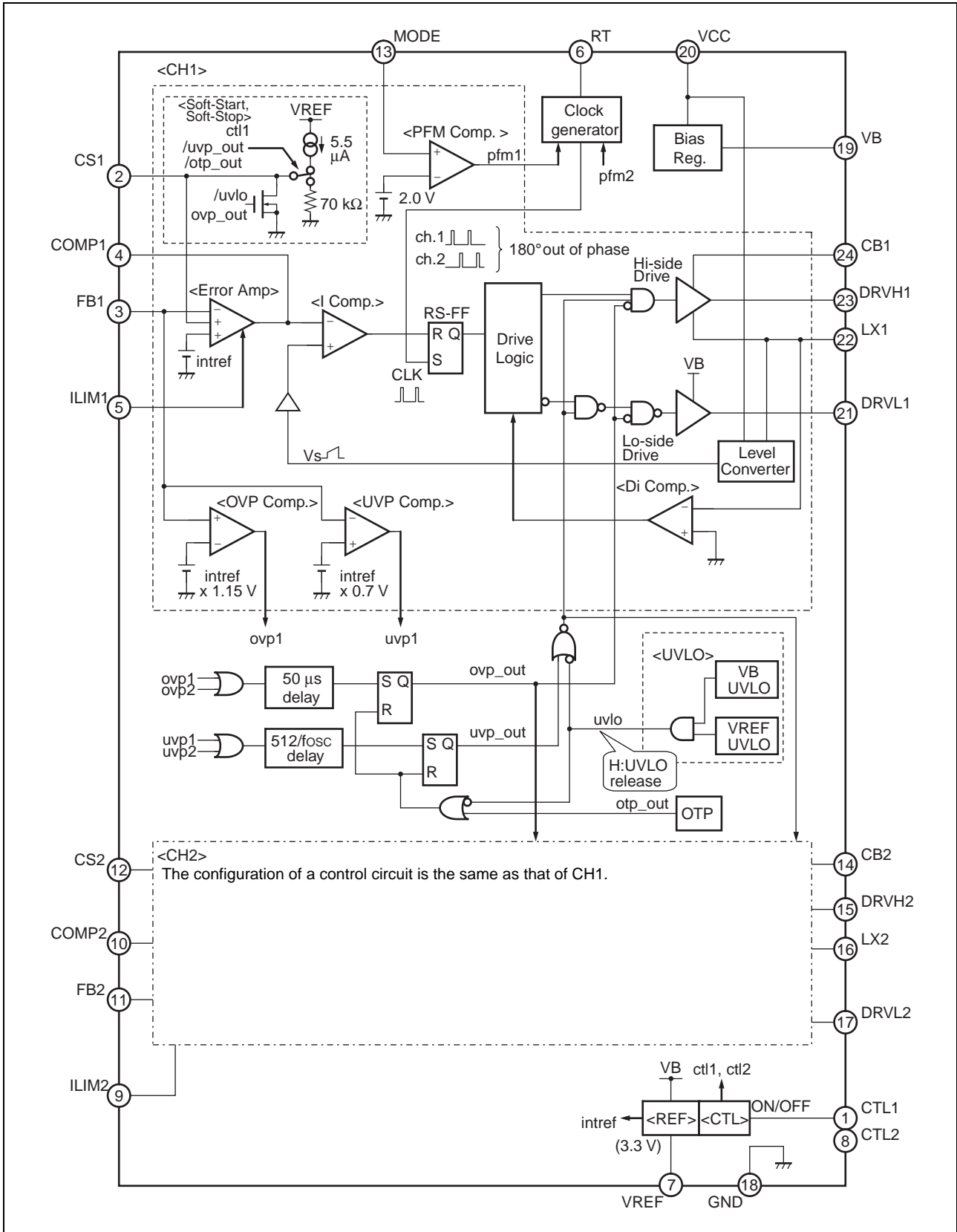

■ ABSOLUTE MAXIMUM RATINGS

Parameter	Symbol	Conditions	Rating		Unit
			Min	Max	
Power-supply voltage	V _{VCC}	VCC pin	—	27	V
CB pin input voltage	V _{CB}	CB1, CB2 pins	—	32	V
LX pin input voltage	V _{LX}	LX1, LX2 pins	—	27	V
Voltage between CB and LX	V _{CBLX}	—	—	7	V
Control input voltage	V _I	CTL1, CTL2 pins	—	27	V
Input voltage	V _{FB}	FB1, FB2 pins	—	V _{VREF} + 0.3	V
	V _{ILIM}	ILIM1, ILIM2 pins	—	V _{VREF} + 0.3	V
	V _{CSx}	CS1, CS2 pins	—	V _{VREF} + 0.3	V
	V _{MODE}	MODE pin	—	V _{VB} + 0.3	V
Output current	I _{OUT}	DC DRVL1, DRVL2 pins, DRVH1, DRVH2 pins	—	60	mA
Power dissipation	P _D	T _a ≤ + 25 °C	—	1644	mW
Storage temperature	T _{STG}	—	- 55	+ 150	°C

WARNING: Semiconductor devices can be permanently damaged by application of stress (voltage, current, temperature, etc.) in excess of absolute maximum ratings. Do not exceed these ratings.

■ RECOMMENDED OPERATING CONDITIONS

Parameter	Symbol	Conditions	Value			Unit
			Min	Typ	Max	
Power supply voltage	V _{VCC}	—	4.5	—	25.0	V
CB pin input voltage	V _{CB}	—	—	—	30	V
Reference voltage output current	I _{VREF}	—	– 100	—	—	μA
Bias output current	I _{VB}	—	– 1	—	—	mA
CTL pin input voltage	V _I	CTL1, CTL2 pins	0	—	25	V
Input voltage	V _{FB}	FB1, FB2 pins	0	—	V _{VREF}	V
	V _{ILIM}	ILIM1, ILIM2 pins	0.3	—	1.94	V
	V _{CS}	CS1, CS2 pins	0	—	V _{VREF}	V
	V _{MODE}	MODE pin	0	—	V _{VREF}	V
Peak output current	I _{OUT}	DRVH1, DRVH2 pins DRVL1, DRVL2 pins Duty ≤ 5% (t = 1/f _{osc} × Duty)	– 1200	—	+ 1200	mA
Operation frequency range	f _{osc}	—	100	500	1000	kHz
Timing resistor	R _{RT}	RT pin	—	47	—	kΩ
Soft start capacitor	C _{CS}	CS1, CS2 pins	0.0075	0.0180	—	μF
CB pin capacitor	C _{CB}	CB1, CB2 pins	—	0.1	1.0	μF
Reference voltage output capacitor	C _{VREF}	VREF pin	—	0.1	1.0	μF
Bias voltage output capacitor	C _{VB}	VB pin	—	2.2	10	μF
Operating ambient temperature	T _a	—	– 30	+ 25	+ 85	°C

WARNING: The recommended operating conditions are required in order to ensure the normal operation of the semiconductor device. All of the device's electrical characteristics are warranted when the device is operated within these ranges.

Always use semiconductor devices within their recommended operating condition ranges. Operation outside these ranges may adversely affect reliability and could result in device failure. No warranty is made with respect to uses, operating conditions, or combinations not represented on the data sheet. Users considering application outside the listed conditions are advised to contact their representatives beforehand.

■ ELECTRICAL CHARACTERISTICS

(Ta = +25 °C, VCC pin = 15 V, CTL pin = 5 V, VREF pin = 0 A, VB pin = 0A)

Parameter		Symbol	Pin No.	Conditions	Value			Unit
					Min	Typ	Max	
Reference Voltage Block [REF]	Output voltage	V _{VREF}	7	—	3.24	3.30	3.36	V
	Input stability	VREF LINE	7	VCC pin = 4.5 V to 25 V	—	1	10	mV
	Load stability	VREF LOAD	7	VREF pin = 0 A to – 100 μA	—	1	10	mV
	Short-circuit output current	VREF IOS	7	VREF pin = 0 V	– 14.5	– 10.0	– 7.5	mA
Bias Voltage Block [VB Reg.]	Output voltage	V _{VB}	19	—	4.85	5.00	5.15	V
	Input stability	VB LINE	19	VCC pin = 6 V to 25 V	—	10	100	mV
	Load stability	VB LOAD	19	VB pin = 0 A to – 1 mA	—	10	100	mV
	Short-circuit output current	VB IOS	19	VB pin = 0 V	– 200	– 140	– 100	mA
Under voltage Lockout Protection Circuit Block [UVLO]	Threshold voltage	V _{TLH1}	19	VB pin	4.0	4.2	4.4	V
		V _{THL1}	19	VB pin	3.4	3.6	3.8	V
	Hysteresis width	V _{H1}	19	VB pin	—	0.6*	—	V
	Threshold voltage	V _{TLH2}	7	VREF pin	2.7	2.9	3.1	V
		V _{THL2}	7	VREF pin	2.5	2.7	2.9	V
Hysteresis width	V _{H2}	7	VREF pin	—	0.2*	—	V	
Soft-start / Soft-stop Block [Soft-Start, Soft-Stop]	Charge current	I _{CS}	2, 12	CTL1, CTL2 pins = 5 V, CS1, CS2 pins = 0 V	– 7.9	– 5.5	– 4.2	μA
	Soft-start end voltage	V _{CS}	2, 12	CTL1, CTL2 pins = 5 V	2.2	2.4	2.6	V
	Electrical discharge resistance at soft-stop	R _{DISCG}	2, 12	CTL1, CTL2 pins = 0 V, CS1, CS2 pins = 0.5 V	49	70	91	kΩ
	Soft-stop end voltage	V _{DISCG}	2, 12	CTL1, CTL2 pins = 0 V	—	0.1*	—	V
Clock Generator Block [OSC]	Oscillation frequency	f _{OSC}	6	RT pin = 47 kΩ	450	500	550	kHz
	Oscillation frequency when under voltage is detected	f _{SHORT}	6	RT pin = 47 kΩ	—	62.5	—	kHz
	Frequency Temperature variation	df/dT	6	Ta = – 30 °C to + 85 °C	—	3*	—	%

(Continued)

MB39A136

(Ta = +25 °C, VCC pin = 15 V, CTL pin = 5 V, VREF pin = 0 A, VB pin = 0 A)

Parameter		Symbol	Pin No.	Conditions	Value			Unit
					Min	Typ	Max	
Error Amp Block [Error Amp1, Error Amp2]	Threshold voltage	EV _{TH}	3, 11	—	0.693	0.700	0.707	V
		EV _{THT}	3, 11	Ta = -30 °C to +85 °C	0.689*	0.700*	0.711*	V
	Input current	I _{FB}	3, 11	FB1, FB2 pins = 0 V	-0.1	0	+0.1	μA
	Output current	I _{SOURCE}	4, 10	FB1, FB2 pins = 0 V, COMP1, COMP2 pins = 1 V	-390	-300	-210	μA
		I _{SINK}	4, 10	FB1, FB2 pins = VREF pin, COMP1, COMP2 pins = 1 V	8.4	12.0	16.8	mA
	Output clamp voltage	V _{ILIM}	4, 10	FB1, FB2 pins = 0 V, ILIM1, ILIM2 pins = 1.5 V	1.35	1.50	1.65	V
ILIM pin input current	I _{ILIM}	5, 9	FB1, FB2 pins = 0 V, ILIM1, ILIM2 pins = 1.5 V	-1	0	+1	μA	
Over-voltage Protection Circuit Block [OVP Comp.]	Over-voltage detecting voltage	V _{OVP}	3, 11	FB1, FB2 pins	0.776	0.805	0.835	V
	Over-voltage detection time	t _{OVP}	3, 11	—	49	70	91	μs
Under-voltage Protection Circuit Block [UVP Comp.]	Under-voltage detecting voltage	V _{UVP}	3, 11	FB1, FB2 pins	0.450	0.490	0.531	V
	Under-voltage detection time	t _{UVP}	3, 11	—	—	512/ fosc	—	s
Over-temperature Protection Circuit Block [OTP]	Detection temperature	T _{OTPH}	—	Junction temperature	—	+160*	—	°C
		T _{OTPL}	—	Junction temperature	—	+135*	—	°C
PFM Control Circuit Block (MODE)	Synchronous rectification stop voltage	V _{THLX}	22, 16	LX1, LX2 pins	—	0*	—	mV
	PFM/PWM mode condition	V _{PFM}	13	MODE pin	0	—	1.4	V
	Fixed PWM mode condition	V _{PWM}	13	MODE pin	2.2	—	V _{VREF}	V
	MODE pin input current	I _{MODE}	13	MODE pin = 0 V	-1	0	+1	μA

(Continued)

(Ta = + 25 °C, VCC pin = 15 V, CTL pin = 5 V, VREF pin = 0 A, VB pin = 0 A)

Parameter		Symbol	Pin No.	Conditions	Value			Unit
					Min	Typ	Max	
Output Block [DRV]	High-side output on-resistance	R _{ON_MH}	23, 15	DRVH1, DRVH2 pins = – 100 mA	—	4	7	Ω
		R _{ON_ML}	23, 15	DRVH1, DRVH2 pins = 100 mA	—	1.0	3.5	Ω
	Low-side output on-resistance	R _{ON_SH}	21, 17	DRVL1, DRVL2 pins = – 100 mA	—	4	7	Ω
		R _{ON_SL}	21, 17	DRVL1, DRVL2 pins = 100 mA	—	0.75	1.70	Ω
	Output source current	I _{SOURCE}	23, 15, 21, 17	LX1, LX2 pins = 0 V, CB1, CB2 pins = 5 V DRVH1, DRVH2 pins, DRVL1, DRVL2 pins = 2.5 V Duty ≤ 5%	—	– 0.5*	—	A
	Output sink current	I _{SINK}	23, 15	LX1, LX2 pins = 0 V, CB1, CB2 pins = 5 V DRVH1, DRVH2 pins = 2.5 V Duty ≤ 5%	—	0.9*	—	A
			21, 17	LX1, LX2 pins = 0 V, CB1, CB2 pins = 5 V DRVL1, DRVL2 pins = 2.5 V Duty ≤ 5%	—	1.2*	—	A
	Minimum on time	t _{ON}	23, 15	COMP1, COMP2 pins = 1 V	—	250*	—	ns
	Maximum on-duty	D _{MAX}	23, 15	FB1, FB2 pins = 0 V	75	80	—	%
Dead time	t _D	23, 21, 15, 17	LX1, LX2 pins = 0 V, CB1, CB2 pins = 5 V	—	60	—	ns	
Level Converter Block [LVCNV]	Maximum current sense voltage	V _{RANGE}	22, 16	VCC pin – LX1, LX2 pins	—	220*	—	mV
	Voltage conversion gain	A _{LV}	22, 16	—	5.4	6.8	8.2	V/V
	Offset voltage at voltage conversion	V _{IO}	22, 16	—	—	300	—	mV
	Slope compensation inclination	SLOPE	22, 16	—	—	2*	—	V/V
	LX pin input current	I _{LX}	22, 16	LX1, LX2 pins = VCC pin	320	420	600	μA

(Continued)

MB39A136

(Continued)

(Ta = + 25 °C, VCC pin = 15 V, CTL pin = 5 V, VREF pin = 0 A, VB pin = 0 A)

Parameter		Symbol	Pin No.	Conditions	Value			Unit
					Min	Typ	Max	
Control Block [CTL1, CTL2]	ON condition	V _{ON}	1, 8	CTL1, CTL2 pins	2	—	25	V
	OFF condition	V _{OFF}	1, 8	CTL1, CTL2 pins	0	—	0.8	V
	Hysteresis width	V _H	1, 8	CTL1, CTL2 pins	—	0.4*	—	V
	Input current	I _{CTLH}	1, 8	CTL1, CTL2 pins = 5 V	—	25	40	μA
I _{CTL}		1, 8	CTL1, CTL2 pins = 0 V	—	0	1	μA	
General	Standby current	I _{CCS}	20	CTL1, CTL2 pins = 0 V	—	0	10	μA
	Power-supply current	I _{CC}	20	LX1, LX2 pins = 0 V, FB1, FB2 pins = 1.0 V, MODE pin = VREF pin	—	3.3	4.7	mA

* : This value is not be specified. This should be used as a reference to support designing the circuits.

■ TYPICAL CHARACTERISTICS

• Typical data

Power dissipation

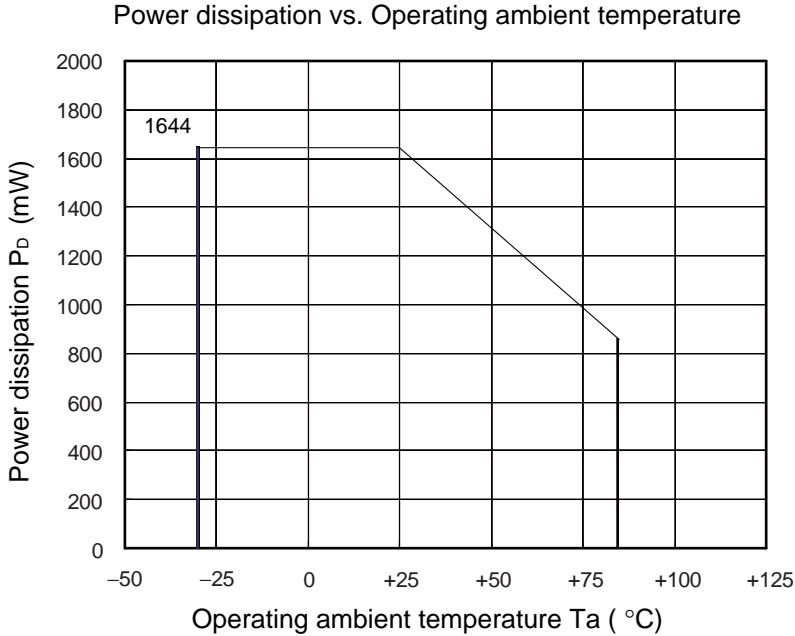

VREF bias voltage vs. Operating ambient temperature

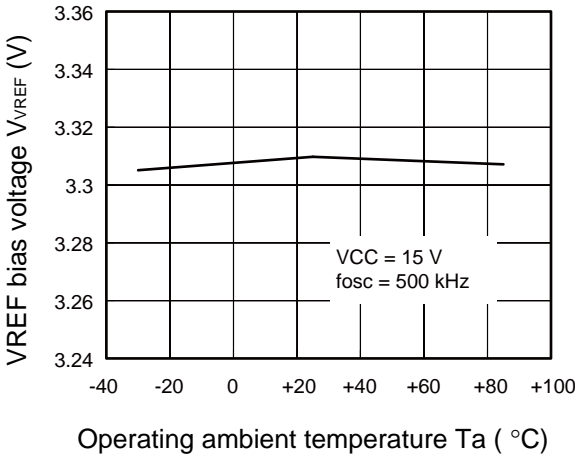

Error Amp threshold voltage vs. Operating ambient temperature

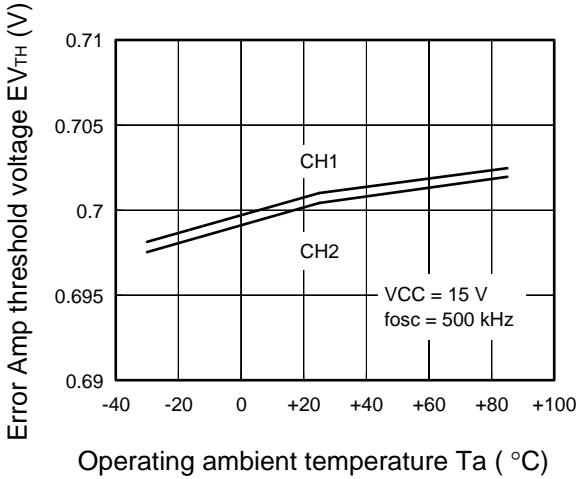

(Continued)

(Continued)

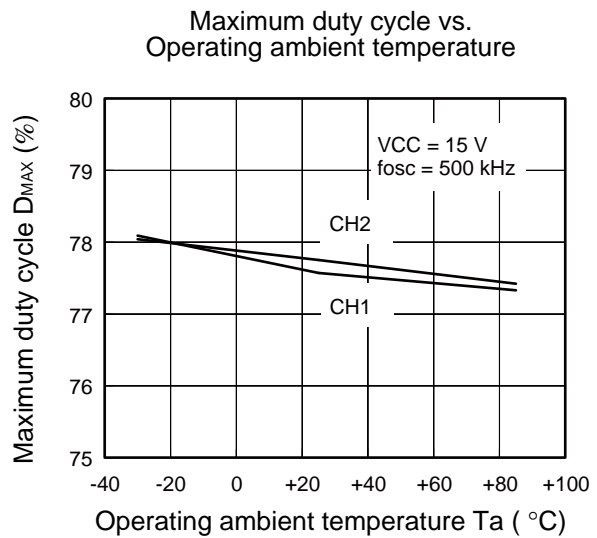
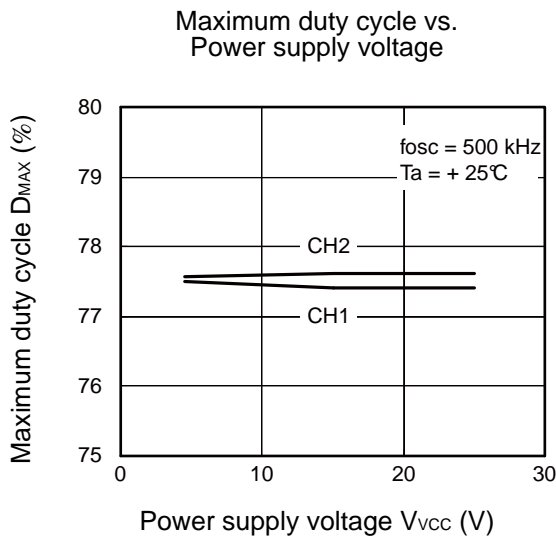
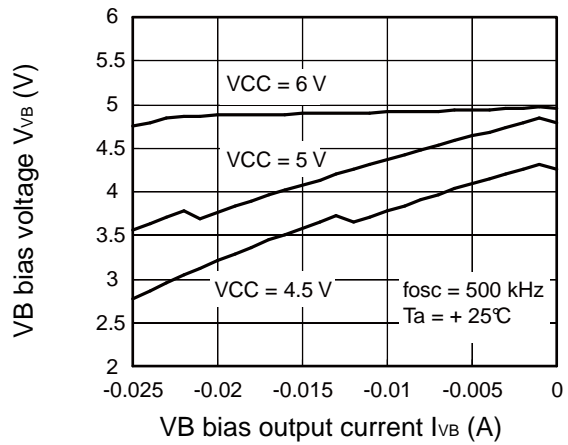
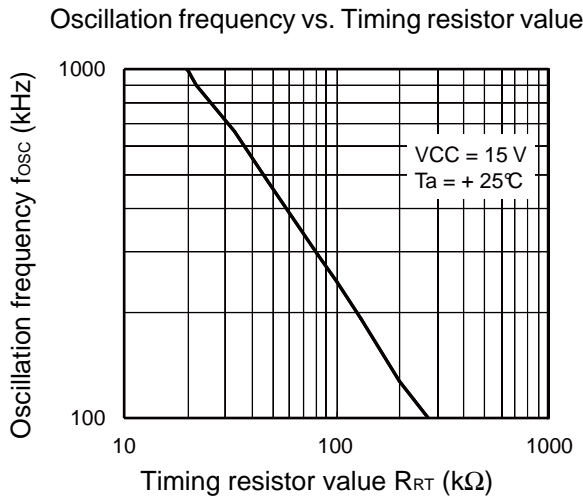
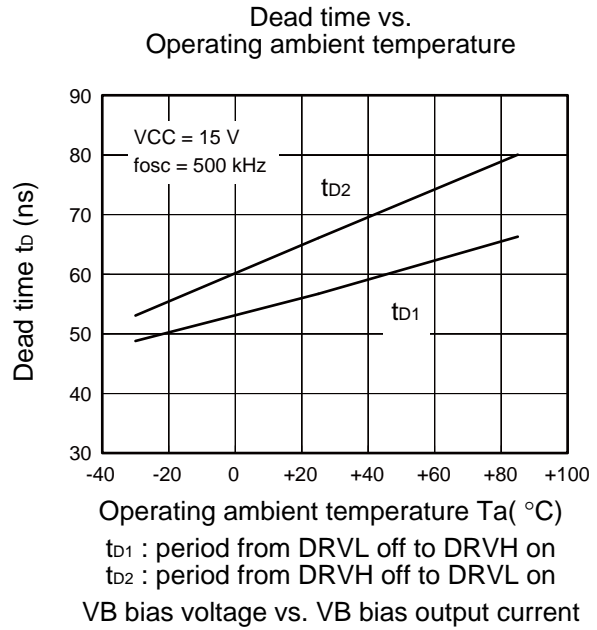
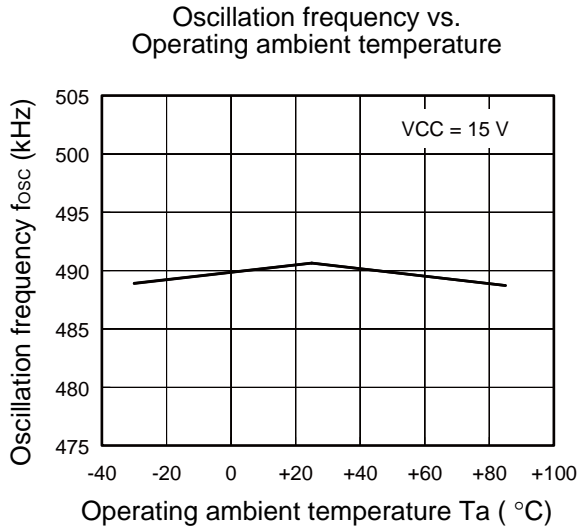

■ FUNCTION DESCRIPTION

1. Current Mode

It uses the current waveform from the switching (Q1) as a control waveform to control the output voltage, as described below:

- 1 : The clock (CK) from the internal clock generator (OSC) sets RS-FF and turns on the high-side FET.
- 2 : Turning on the high-side FET causes the inductor current (IL) rise. Generate V_s that converts this current into the voltage.
- 3 : The current comparator (I Comp.) compares this V_s with the output (COMP) from the error amplifier (Error Amp) that is negative-feedback from the output voltage (V_o).
- 4 : When I Comp. detects that V_s exceeds COMP, it resets RS-FF and turns off high-side FET.
- 5 : The clock (CK) from the clock generator (OSC) turns on the high-side FET again.

Thus, switching is repeated.

Operate so that the FB electrical potential may become INTREF electrical potential, and stabilize the output voltage as a feedback control.

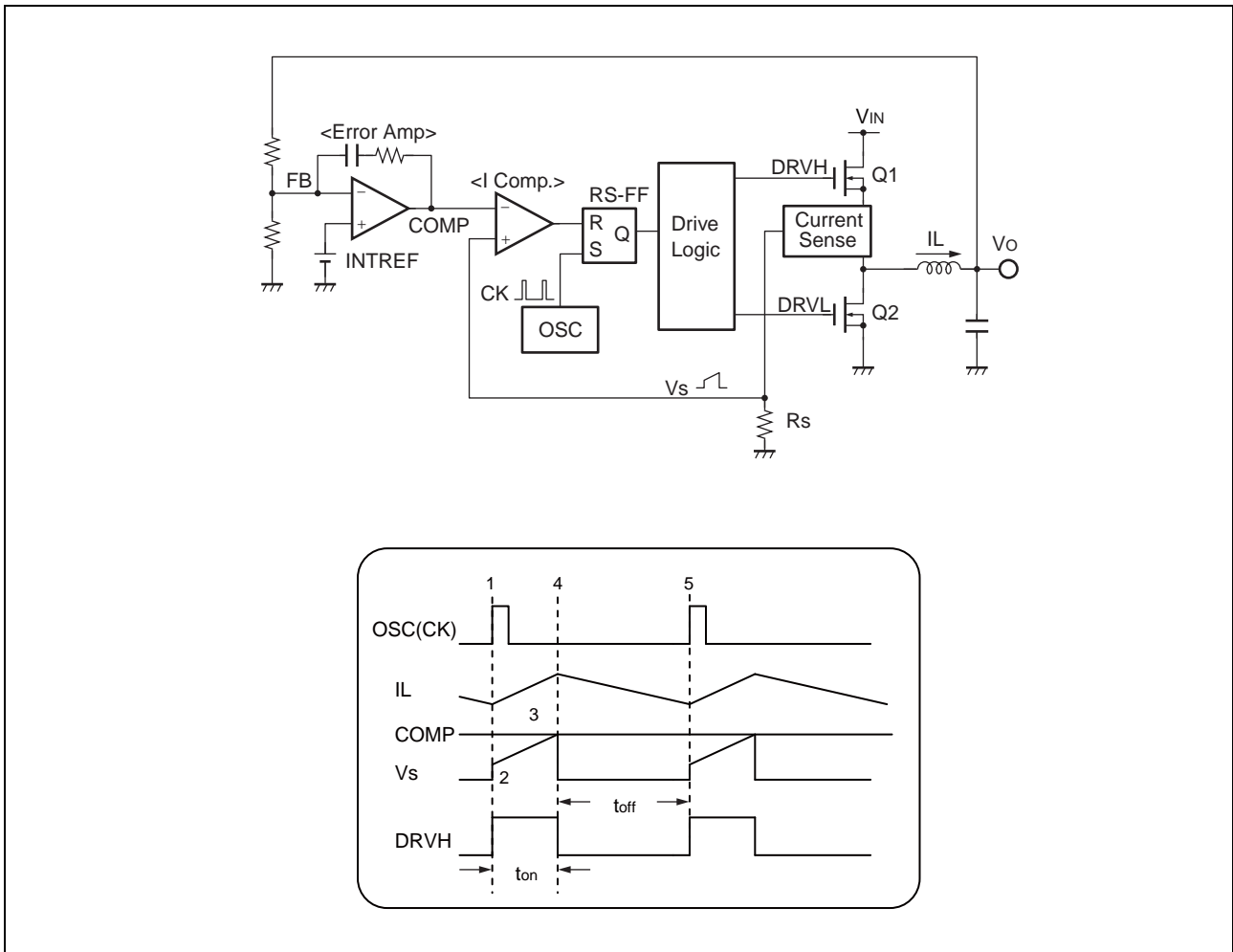

(1) Reference Voltage Block (REF)

The reference voltage circuit (REF) generates a temperature-compensated reference voltage (3.3 [V] Typ) using the voltage supplied from the VCC pin. The voltage is used as the reference voltage for the IC's internal circuit. The reference voltage can be used to supply a load current of up to 100 μ A to an external device through the VREF pin.

(2) Bias Voltage Block (VB Reg.)

Bias Voltage Block (VB Reg.) generates the reference voltage used for IC's internal circuit, using the voltage supplied from the VCC pin. The reference voltage is a temperature-compensated stable voltage (5 [V] Typ) to supply a current of up to 100 mA through the VB pin.

(3) Under Voltage Lockout Protection Circuit Block (UVLO)

The circuit protects against IC malfunction and system destruction/deterioration in a transitional state or a momentary drop when a bias voltage (VB) or an internal reference voltage (VREF) starts. It detects a voltage drop at the VB pin or the VREF pin and stops IC operation. When voltages at the VB pin and the VREF pin exceed the threshold voltage of the under voltage lockout protection circuit, the system is restored.

(4) Soft-start/Soft-stop Block (Soft-Start, Soft-Stop)

Soft-start

It protects a rush current or an output voltage (V_{ox}) from overshooting at the output start. Since the lamp voltage generated by charging the capacitor connecting to the CSx pin is used for the reference voltage of the error amplifier (Error Amp), it can set the soft-start time independent of a load of the output (V_{ox}). When the IC starts with "H" level of the CTLx pin, the capacitor at the CSx pin (CS) starts to be charged at 5.5 μ A. The output voltage (V_{ox}) during the soft-start period rises in proportion to the voltage at the CSx pin generated by charging the capacitor at the CSx pin.

During the soft-start with 0.8 V > voltage at CS1 and CS2 pins, operations are as follows:

- Fixed PWM operation only (fixed PWM even if MODE pin is set to "L")
- Over-voltage protection function and under-voltage protection function are invalid.

Soft-stop

It discharges electrical charges stored in a smoothing capacitor at output stop. Setting the CTLx pin to "L" level starts the soft-stop function independent of a load of output (V_{ox}). Since the capacitor connecting to the CSx pin starts to discharge through the IC-built-in soft-stop discharging resistance (70 [k Ω] Typ) when the CTLx pin sets at "L" level enters its lamp voltage into the error amplifier (Error Amp), the soft-stop time can be set independent of a load of output (V_{ox}). When discharging causes the voltage at the CSx pin to drop below 100 mV (Typ), the IC shuts down and changes to the stand-by state. In addition, the soft-stop function operates after the under-voltage protection circuit block (UVP Comp.) is latched or after the over-temperature protection circuit block (OTP) detects over-temperature.

During the soft-stop with, 0.8 V > voltage at CS1 and CS2 pins, operations are as follows:

- Fixed PWM operation only (fixed PWM even if MODE pin is set to "L")
- Over-voltage protection function and under-voltage protection function are invalid.

(5) Clock Generator Block (OSC)

The clock generator has the built-in oscillation frequency setting capacitor and generates a clock that 180° phase shifted from each channel by connecting the oscillation frequency setting resistor to the RT pin (Symmetrical-Phase method).

(6-1) Error Amp Block (Error Amp1, Error Amp2)

The error amplifiers (Error Amp1 and Error Amp2) detect the output voltage from the DC/DC converter and output to the current comparators (I Comp.1 and I Comp.2). The output voltage setting resistor externally connected to FB1 and FB2 pins allows an arbitrary output voltage to be set.

In addition, since an external resistor and an external capacitor serially connected between COMP1 and FB1 pins and between COMP2 and FB2 pins allow an arbitrary loop gain to be set, it is possible for the system to compensate a phase stably.

(6-2) Over Current Detection (Protection) Block (ILIM)

It is the current detection circuit to restrict an output current (I_{ox}). The over current detection block (ILIM) compares an output waveform of the level converter of each channel (see “(12) Level Converter Block (LVCNV)”) with the ILIMx pin voltage in every cycle. As a load resistance (R_{ox}) drops, a load current (I_{ox}) increases. Therefore, the output waveform of the level converter exceeds the ILIM pin voltage of each channel. At this time, the output current can be restricted by turning off FET on the high-side and suppressing a peak value of the inductor current.

As a result, the output voltage (V_{ox}) should drop.

Furthermore, if the output voltage drops and the electrical potential at the FBx pin drops below 0.3 V, the oscillation frequency (f_{osc}) drops to 1/8.

(7) Over-voltage Protection Circuit Block (OVP Comp.)

The circuit protects a device connecting to the output when the output voltage (V_{ox}) rises.

It compares 1.15 times (Typ) of the internal reference voltage (INTREF) (0.7 V) that is non-inverting-entered into the error amplifier with the feedback voltage that is inverting-entered into the error amplifier and if it detects the state where the latter is higher than the former by 50 μ s (Typ). It stops the voltage output by setting the RS latch, setting the DRVHx pin to “L” level, setting the DRVLx pin to “H” level, turning off the high-side FETs, and turning on the low-side FETs.

The conditions below cancel the protection function:

- Setting CTL1 and CTL2 to “L”.
- Setting the power supply voltage below the UVLO threshold voltage (V_{THL1} and V_{THL2}).

(8) Under-voltage Protection Circuit Block (UVP Comp.)

It protects a device connecting to the output by stopping the output when the output voltage (V_{ox}) drops.

It compares 0.7 times (Typ) of the internal reference voltage (INTREF) (0.7 V) that is non-inverting-entered into the error amplifier with the feedback voltage that is inverting-entered into the error amplifier and if it detects the state where the latter is lower than the former by $512/f_{osc}$ [s] (Typ), it stops the voltage output for both channels by setting the RS latch.

The conditions below cancel the protection function:

- Setting CTL1 and CTL2 to “L”.
- Setting the power supply voltage below the UVLO threshold voltage (V_{THL1} and V_{THL2}).

(9) Over temperature Protection Circuit Block (OTP)

The circuit protects an IC from heat-destruction. If the temperature at the joint part reaches +160 °C, the circuit stops the voltage output for both channels by discharging the capacitor connecting to the CSx pin through the soft-stop discharging resistance (70 [k Ω] Typ) in the IC.

In addition, if the temperature at the joint part drops to +135 °C, the output restarts again through the soft-start function.

Make sure to design the DC/DC power supply system so that the over temperature protection does not start frequently.

(10) PFM Control Circuit Block (MODE)

It sets the control mode of the IC and makes control at automatic PFM/PWM switching.

MODE pin connection	Control mode	Features
"L" (GND)	Automatic PFM/PWM switching	Highly-efficient at light load
"H" (VREF)	Fixed PWM	Stable oscillation frequency Stable switching ripple voltage Excellent in rapid load change characteristic at heavy load to light load

Automatic PFM/PWM switching mode operation

It compares the LX1 pin and the LX2 pin voltages with GND electrical potential at Di Comp. In the comparison, the negative voltage at the LX pin causes the low-side FET to set on, positive voltage causes it to set off (Di Comp. method) . As a result, the method restricts the back flow of the inductor current at a light load and makes the switching of the inductor current discontinuous (DCM) . Such an operation allows the oscillation frequency to drop, resulting in high efficiency at a light load.

(11) Output Block (DRV)

The output circuit is configured in CMOS type for both of the high-side and the low-side, allowing the external N-ch MOS FET to drive.

(12) Level Converter Block (LVCNV)

The circuit detects and converts the current when the high-side FET turns on. It converts the voltage waveform between drain side (VCC pin voltage) and the source side (LX1 and LX2 pin voltage) on the high-side FET into the voltage waveform for GND reference.

Note: x : Each channel number

(13) Control Block (CTL1, CTL2)

The circuit controls on/off of the output from the IC.

Control function table

CTL1	CTL2	DC/DC converter (Vo1)	DC/DC converter (Vo2)	Remarks
L	L	OFF	OFF	Standby
H	L	ON	OFF	—
L	H	OFF	ON	—
H	H	ON	ON	—

■ PROTECTION FUNCTION TABLE

The following table shows the state of each pin when each protection function operates.

Protection Function	Detection condition	Output of each pin after detection				DC/DC output dropping operation
		VREF	VB	DRVHx	DRVLx	
Under Voltage Lock Out Protection (UVLO)	VB < 3.6 V VREF < 2.7 V	< 2.7 V	< 3.6 V	L	L	Self-discharge by load
Under Voltage Protection (UVP)	FBx < 0.49 V	3.3 V	5 V	L	L	Electrical discharge by soft-stop function
Over Voltage Protection (OVP)	FBx > 0.805 V	3.3 V	5 V	L	H	0 V clamping
Over Current Protection (ILIM)	COMPx > ILIMx	3.3 V	5V	switching	switching	The output voltage is dropping to keep constant output current.
Over Temperature Protection (OTP)	Tj > + 160 °C	3.3 V	5 V	L	L	Electrical discharge by soft-stop function
CONTROL (CTL)	CTLx : H→L (CSx > 0.1 V)	3.3 V	5 V	L	L	

Note: x is the each channel number

I/O PIN EQUIVALENT CIRCUIT DIAGRAM

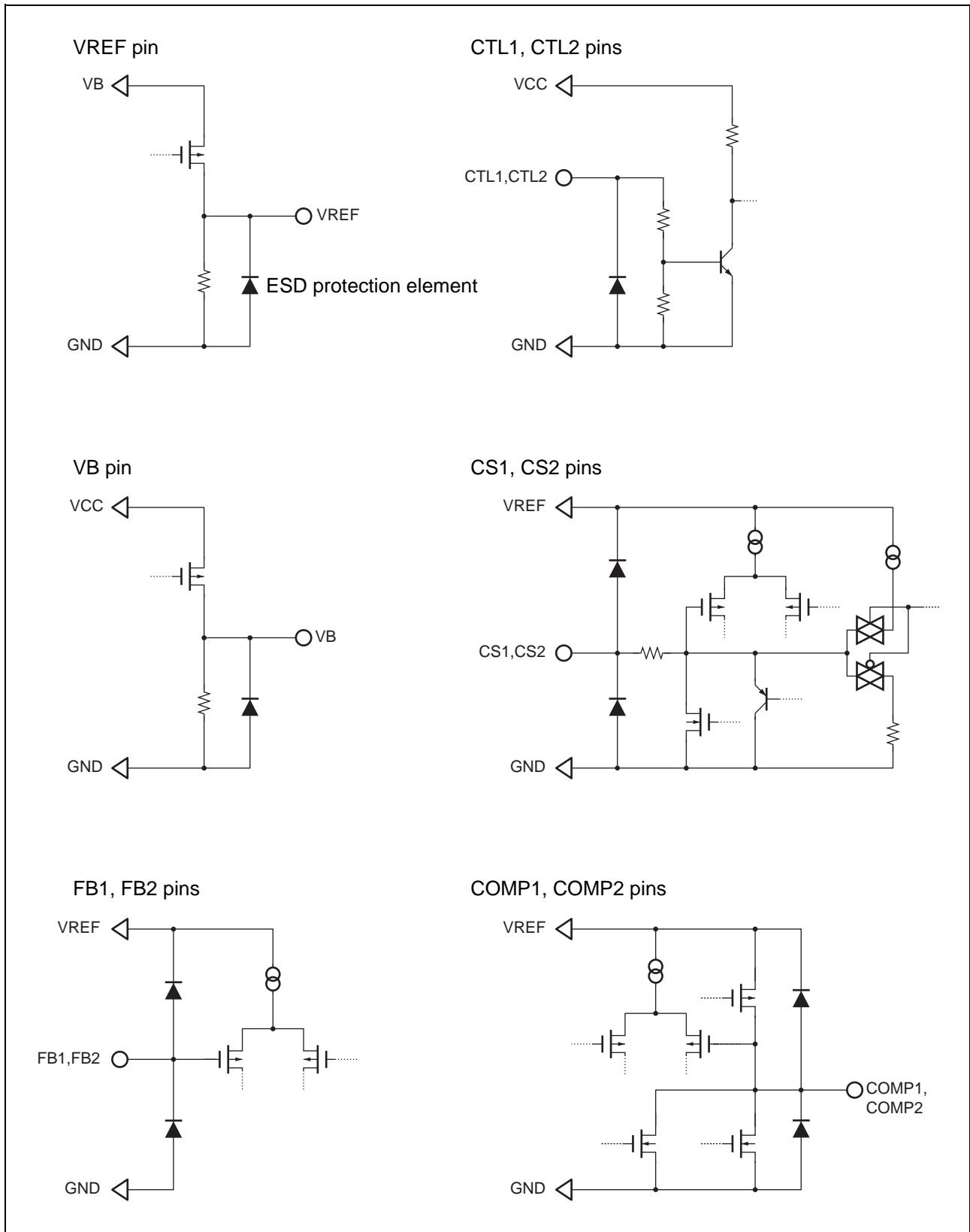

(Continued)

(Continued)

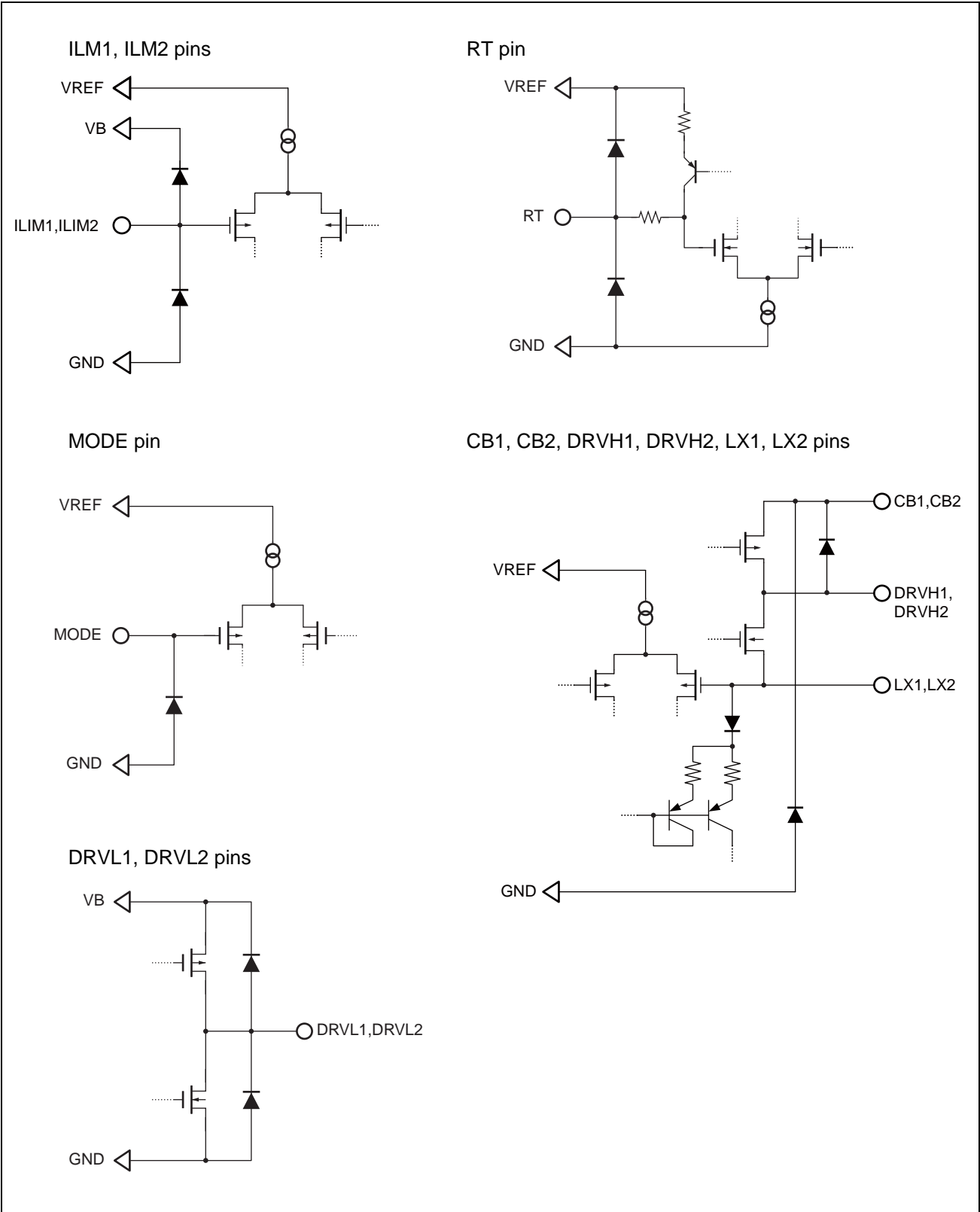

MB39A136

EXAMPLE APPLICATION CIRCUIT

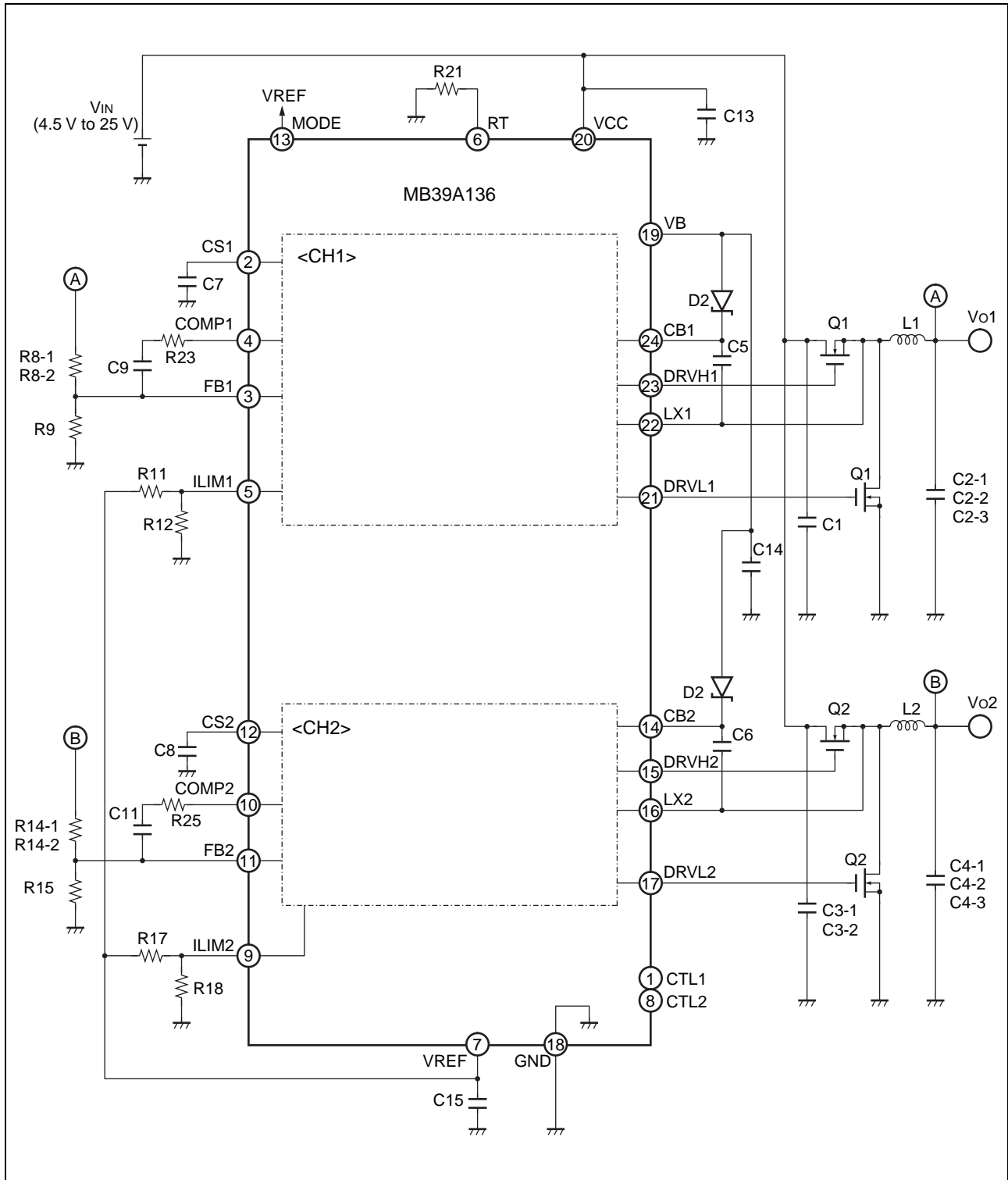

■ PARTS LIST

Component	Item	Specification	Vendor	Package	Parts Name	Remark
Q1	N-ch FET	VDS = 30 V, ID = 8 A, Ron = 21 mΩ	RENESAS	SO-8	μPA2755	Dual type (2 elements)
Q2	N-ch FET	VDS = 30 V, ID = 8 A, Ron = 21 mΩ	RENESAS	SO-8	μPA2755	Dual type (2 elements)
D2	Diode	VF = 0.35 V at IF = 0.2 A	ON Semi	SOT-323	BAT54AWT1	Dual type
L1	Inductor	1.5 μH (6.2 mΩ, 8.9 A)	TDK	—	VLF10040T-1R5N	
L2	Inductor	3.3 μH (9.7 mΩ, 6.9 A)	TDK	—	VLF10045T-3R3N	
C1	Ceramic capacitor	22 μF (25 V)	TDK	3225	C3225JC1E226M	
C2-1	Ceramic capacitor	22 μF (10 V)	TDK	3216	C3216JB1A226M	3 capacitors in parallel
C2-2	Ceramic capacitor	22 μF (10 V)	TDK	3216	C3216JB1A226M	
C2-3	Ceramic capacitor	22 μF (10 V)	TDK	3216	C3216JB1A226M	
C3-1	Ceramic capacitor	22 μF (25 V)	TDK	3225	C3225JC1E226M	2 capacitors in parallel
C3-2	Ceramic capacitor	22 μF (25 V)	TDK	3225	C3225JC1E226M	
C4-1	Ceramic capacitor	22 μF (10 V)	TDK	3216	C3216JB1A226M	3 capacitors in parallel
C4-2	Ceramic capacitor	22 μF (10 V)	TDK	3216	C3216JB1A226M	
C4-3	Ceramic capacitor	22 μF (10 V)	TDK	3216	C3216JB1A226M	
C5	Ceramic capacitor	0.1 μF (50 V)	TDK	1608	C1608JB1H104K	
C6	Ceramic capacitor	0.1 μF (50 V)	TDK	1608	C1608JB1H104K	
C7	Ceramic capacitor	0.022 μF (50 V)	TDK	1608	C1608JB1H223K	
C8	Ceramic capacitor	0.022 μF (50 V)	TDK	1608	C1608JB1H223K	
C9	Ceramic capacitor	820 pF (50 V)	TDK	1608	C1608CH1H821J	
C11	Ceramic capacitor	1000 pF (50 V)	TDK	1608	C1608CH1H102J	
C13	Ceramic capacitor	0.01 μF (50 V)	TDK	1608	C1608JB1H103K	
C14	Ceramic capacitor	2.2 μF (16 V)	TDK	1608	C1608JB1C225K	
C15	Ceramic capacitor	0.1 μF (50 V)	TDK	1608	C1608JB1H104K	
R8-1	Resistor	1.6 kΩ	SSM	1608	RR0816P162D	2 capacitors in series
R8-2		9.1 kΩ	SSM	1608	RR0816P912D	
R9	Resistor	15 kΩ	SSM	1608	RR0816P153D	
R11	Resistor	56 kΩ	SSM	1608	RR0816P563D	
R12	Resistor	47 kΩ	SSM	1608	RR0816P473D	
R14-1	Resistor	1.8 kΩ	SSM	1608	RR0816P182D	2 capacitors in series
R14-2		39 kΩ	SSM	1608	RR0816P393D	
R15	Resistor	11 kΩ	SSM	1608	RR0816P113D	

(Continued)

MB39A136

(Continued)

Component	Item	Specification	Vendor	Package	Parts Name	Remark
R17	Resistor	56 k Ω	SSM	1608	RR0816P563D	
R18	Resistor	56 k Ω	SSM	1608	RR0816P563D	
R21	Resistor	82 k Ω	SSM	1608	RR0816P823D	
R23	Resistor	22 k Ω	SSM	1608	RR0816P223D	
R25	Resistor	56 k Ω	SSM	1608	RR0816P563D	

RENESAS : Renesas Electronics Corporation

ON Semi : ON Semiconductor

TDK : TDK Corporation

SSM : SUSUMU Co.,Ltd.

■ APPLICATION NOTE

Setting method for PFM/PWM and fixed PWM modes

For the setting method for each mode, see“■ FUNCTION DESCRIPTION (10) PFM Control Circuit Block (MODE)”.

Cautions at PFM/PWM mode

If a load current drops rapidly because of rapid load change and others, it tends to take a lot of time to restore overshooting of an output voltage.

As a result, the over-voltage protection may operate.

In this case, solution are possible by the addition of the load resistance of value to be able to restore the output voltage in the over-voltage detection time.

Setting method of output voltage

Set it by adjusting the output voltage setting zero-power resistance ratio.

$$V_o = \frac{R1 + R2}{R2} \times 0.7$$

V_o : Output setting voltage [V]

$R1, R2$: Output setting resistor value [Ω]

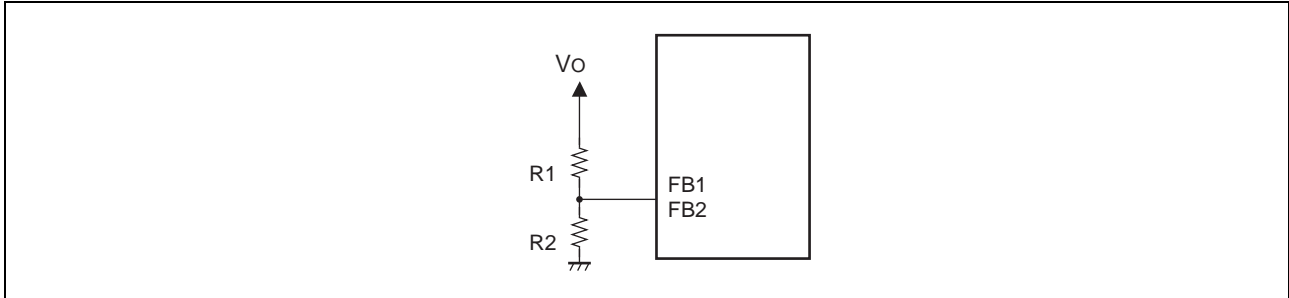

Make sure that the setting does not exceed the maximum on-duty.

Calculate the on-duty by the following formula:

$$D_{MAX_Min} = \frac{V_o + R_{ON_Sync} \times I_{OMAX}}{V_{IN} - R_{ON_Main} \times I_{OMAX} + R_{ON_Sync} \times I_{OMAX}}$$

D_{MAX_Min} : Minimum value of the maximum on-duty cycle

V_{IN} : Power supply voltage of switching system [V]

V_o : Output setting voltage [V]

R_{ON_Main} : High-side FET ON resistance [Ω]

R_{ON_Sync} : Low-side FET ON resistance [Ω]

I_{OMAX} : Maximum load current[A]

Oscillation frequency setting method

Set it by adjusting the RT pin resistor value.

$$f_{osc} = \frac{1.09}{R_{RT} \times 40 \times 10^{-12} + 300 \times 10^{-9}}$$

R_{RT} : RT resistor value [Ω]
 f_{osc} : Oscillation frequency [Hz]

The oscillation frequency must set for on-time (t_{ON}) to become 300ns or more.
Calculate the on-time by the following formula.

$$t_{ON} = \frac{V_O}{V_{IN} \times f_{osc}}$$

t_{ON} : On-time [s]
 V_{IN} : Power supply voltage of switching system [V]
 V_O : Output setting voltage [V]
 f_{osc} : Oscillation frequency [Hz]

Setting method of soft-start time

Calculate the soft-start time by the following formula.

$$t_s = 1.4 \times 10^5 \times C_{CS}$$

t_s : Soft-start time[s] (Time to becoming output 100%)

C_{CS} : CS pin capacitor value [F]

Calculate delay time until the soft-start beginning by the following formula.

$$t_{d1} = 30 \times C_{VB} + 290 \times C_{VREF} + 1.455 \times 10^4 \times C_{CS}$$

t_{d1} : Delay time including VB voltage and VREF voltage starts [s]

C_{CS} : CS pin capacitor value [F]

C_{VB} : VB pin capacitor value [F]

C_{VREF} : VREF pin capacitor value [F] (0.1 [μF] Typ)

Calculate delay time for starting while one channel has already started (UVLO released : VB, VREF output before) by the following formula.

$$t_{d2} = 1.455 \times 10^4 \times C_{CS}$$

t_{d2} : Delay time for starting while one channel has already started [s]

C_{CS} : CS pin capacitor value [F]

Calculate the discharge time at the soft-stop by the following formula.

$$t_{dis} = 1.44 \times 10^5 \times C_{CS}$$

t_{dis} : Discharge time [s]

C_{CS} : CS pin capacitor value [F]

In addition, calculate the delay time to the discharge starting by the following formula.

$$t_{d3} = 7.87 \times 10^4 \times C_{CS}$$

t_{d3} : Delay time until discharge start [s]

C_{CS} : CS pin capacitor value [F]

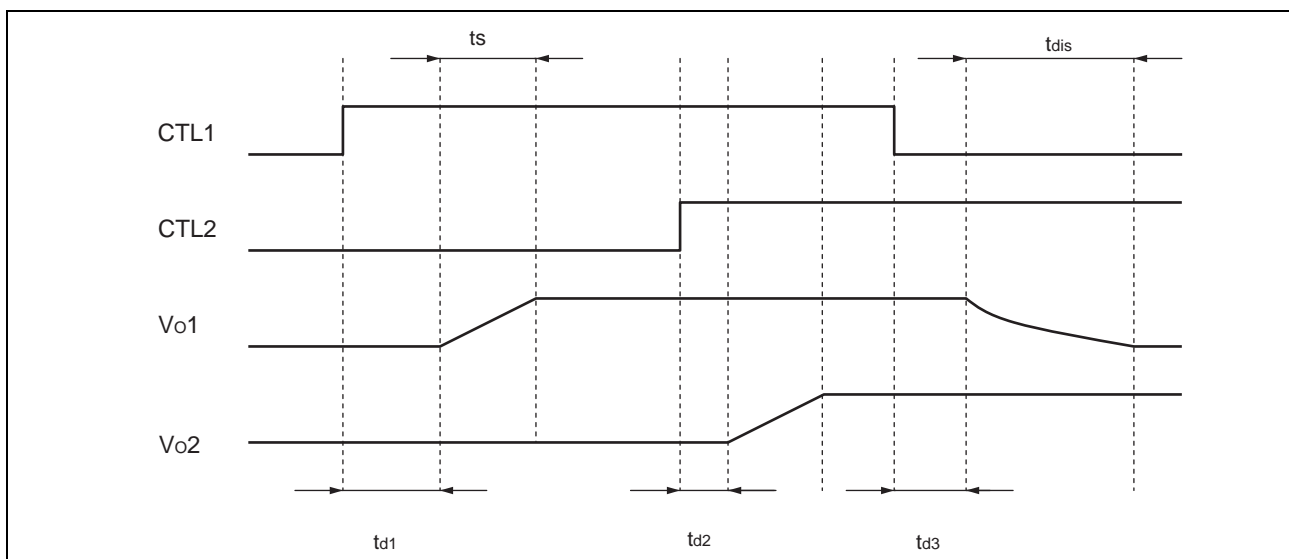

MB39A136

- Simultaneous operation of plural channels

Soft-start/soft-stop operation according to the same timing as two channels can be achieved by even connecting it as shown in the figure below at the power supply on/off.

<Connection example 1> When you adjust the soft-start time

Make the CS capacitor common. Connect CTL1 and CTL2.

Note: In this case, the soft-start time (t_s), the discharge time (t_{dis}), and the delay time (t_{d1} , t_{d2} , t_{d3}) decrease in the half value of compared with when CS capacitor is connected to each channel.

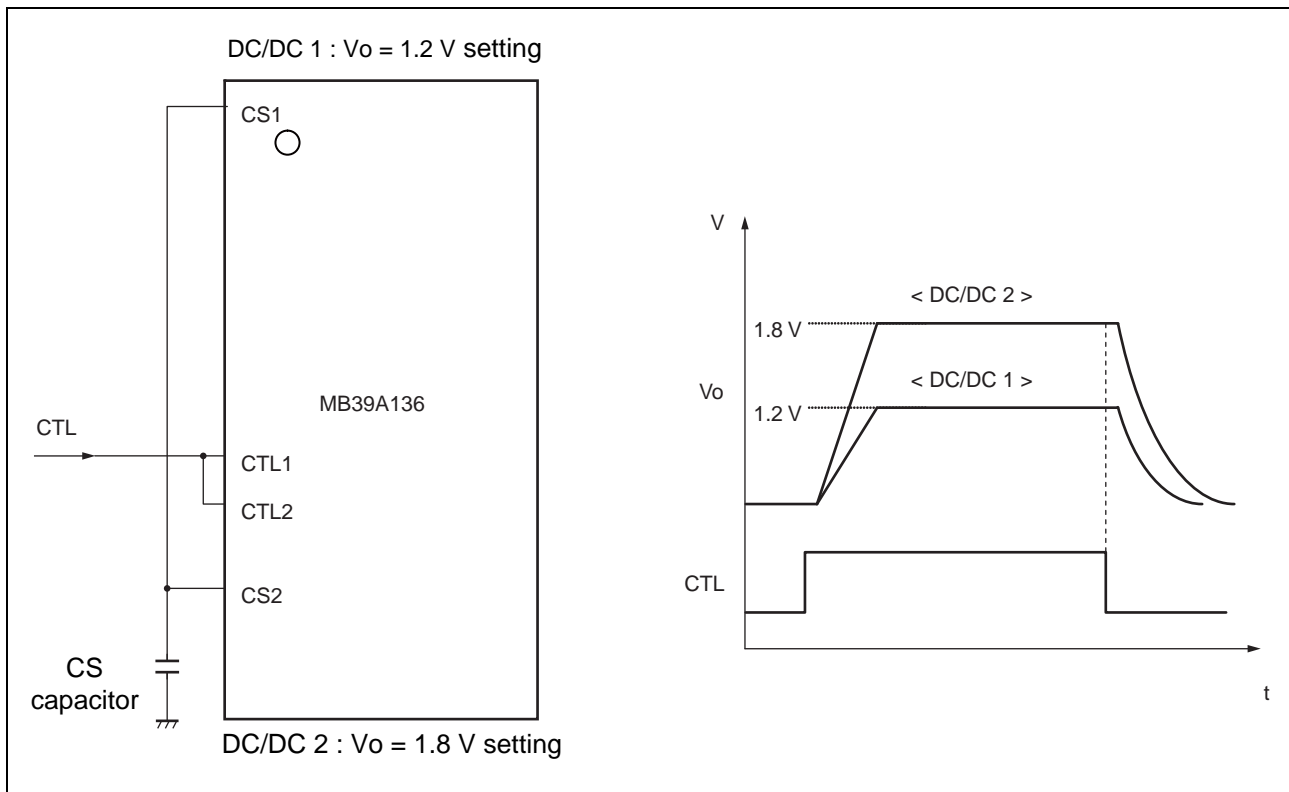

Setting method of over current detection value

It is possible to set over-current detection value (I_{LIM}) by adjusting the over-current detection setting resistor value ratio.

Calculate the over current detection setting resistor value by the following formula.

$$I_{LIM} = \frac{\frac{3.3 \times R2}{R1 + R2} - 0.3}{6.8 \times R_{ON}} + \frac{V_{IN} - V_O}{L} \times (200 \times 10^{-9} - \frac{V_O}{2 \times f_{OSC} \times V_{IN}})$$

$$200 \times 10^3 \geq R1 + R2 \geq 30 \times 10^3$$

- I_{LIM} : Over current detection value [A]
- $R1, R2$: I_{LIM} setting resistor value [Ω]*
- L : Inductor value [H]
- V_{IN} : Power supply voltage of switching system [V]
- V_O : Output setting voltage [V]
- f_{OSC} : Oscillation frequency [Hz]
- R_{ON} : High-side FET ON resistance [Ω]

- * Since the over current detection value depends on the on-resistance of FET, the over current detection setting resistor value ratio should be adjusted in consideration of the temperature characteristics of the on-resistance. When the temperature at the FET joint part rises by +100 °C, the on-resistance of FET increases to about 1.5 times.

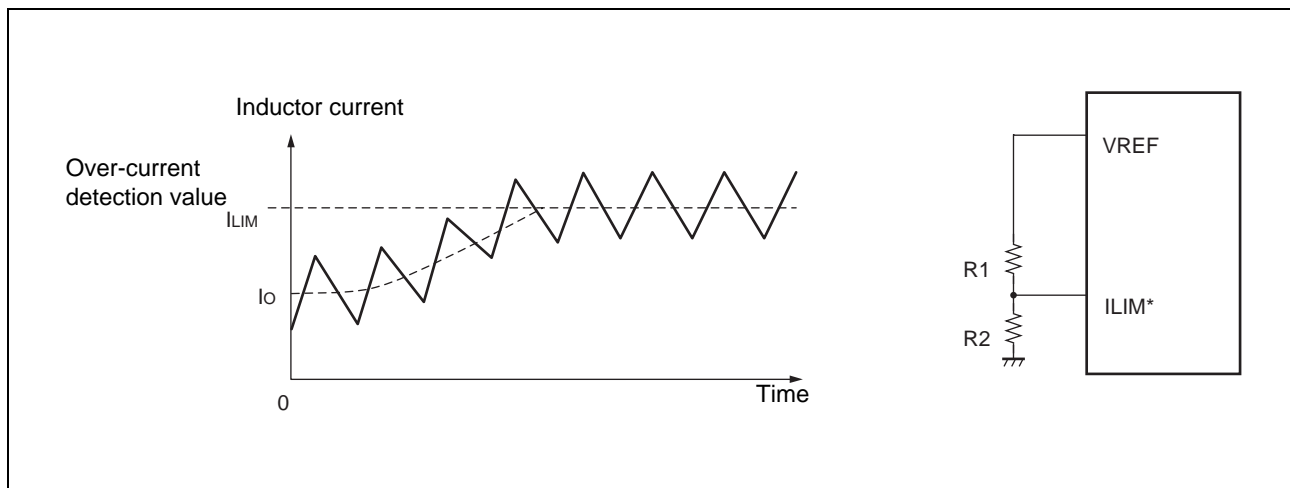

- * If the over current detection function is not used, connect the ILIM pin (ILIM1 and ILIM2) to the VREF pin.

Selection of smoothing inductor

The inductor value selects the value that the ripple current peak-to-peak value becomes 50% or less of the maximum load current as a rough standard. Calculate the inductor value in this case by the following formula.

$$L \geq \frac{V_{IN} - V_O}{LOR \times I_{OMAX}} \times \frac{V_O}{V_{IN} \times f_{OSC}}$$

- L : Inductor value [H]
- I_{OMAX} : Maximum load current [A]
- LOR : Ripple current peak-to-peak value of Maximum load current ratio (=0.5)
- V_{IN} : Power supply voltage of switching system [V]
- V_O : Output setting voltage [V]
- f_{OSC} : Oscillation frequency [Hz]

An inductor ripple current value limited on the principle of operation is necessary for this device. However, when it uses the high-side FET of the low R_{ON} resistance, the switching ripple voltage become small, and the inductor ripple current value may become insufficient. This should be solved by the oscillation frequency or reducing the inductor value.

Select the one of the inductor value that meets a requirement listed below.

$$L \leq \frac{V_{IN} - V_O}{\Delta V_{RON}} \times \frac{V_O}{V_{IN} \times f_{OSC}} \times R_{ON}$$

- L : Inductor value [H]
- V_{IN} : Power supply voltage of switching system [V]
- V_O : Output setting voltage [V]
- f_{OSC} : Oscillation frequency [Hz]
- ΔV_{RON} : Ripple voltage [V] (20 mV or more is recommended)
- R_{ON} : High-side FET ON resistance [Ω]

It is necessary to calculate the maximum current value that flows to the inductor to judge whether the electric current that flows to the inductor is a rated value or less. Calculate the maximum current value of the inductor by the following formula.

$$I_{LMAX} \geq I_{OMAX} + \frac{\Delta IL}{2}, \Delta IL = \frac{V_{IN} - V_O}{L} \times \frac{V_O}{V_{IN} \times f_{OSC}}$$

- I_{LMAX} : Maximum current value of inductor [A]
- I_{OMAX} : Maximum load current [A]
- ΔIL : Ripple current peak-to-peak value of inductor [A]
- L : Inductor value [H]
- V_{IN} : Power supply voltage of switching system [V]
- V_O : Output setting voltage [V]
- f_{OSC} : Oscillation frequency [Hz]

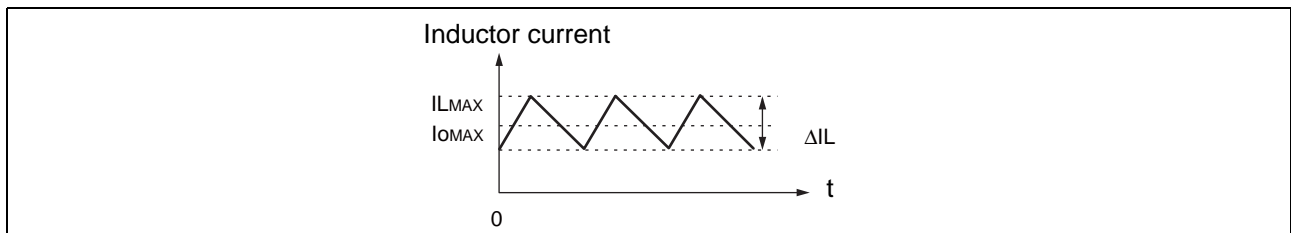

Selection of SWFET

The switching ripple voltage generated between drain and sources on high-side FET is necessary for this device operation. Select the one of the SWFET of on-resistance that satisfies the following formula.

$$R_{ON_Main} \geq \frac{\Delta V_{RON_Main}}{\Delta IL}, R_{ON_Main} \leq \frac{V_{RONMAX}}{I_{LIM} + \frac{\Delta IL}{2}}$$

- R_{ON_Main} : High-side FET ON resistance [Ω]
- ΔIL : Ripple current peak-to-peak value of inductor [A]
- ΔV_{RON_Main} : High-side FET ripple voltage [V] (20mV or more is recommended)
- I_{LIM} : Over current detection value [A]
- V_{RONMAX} : Maximum current sense voltage [V] (240mV or less is recommended)

Select FET ratings with a margin enough for the input voltage and the load current. Ratings with the over-current detection setting value or more are recommended.

Calculate a necessary rated value of high-side FET and low-side FET by the following formula.

$$I_D > I_{O_MAX} + \frac{\Delta IL}{2}$$

- I_D : Rated drain current [A]
- I_{O_MAX} : Maximum load current [A]
- ΔIL : Ripple current peak-to-peak value of inductor [A]

$$V_{DS} > V_{IN}$$

- V_{DS} : Rated voltage between drain and source [V]
- V_{IN} : Power supply voltage of switching system [V]

$$V_{GS} > V_B$$

- V_{GS} : Rated voltage between gate and source [V]
- V_B : VB voltage [V]

Moreover, it is necessary to calculate the loss of SWFET to judge whether a permissible loss of SWFET is a rated value or less. Calculate the loss on high-side FET by the following formula.

$$P_{MainFET} = P_{RON_Main} + P_{SW_Main}$$

- $P_{MainFET}$: High-side FET loss [W]
- P_{RON_Main} : High-side FET conduction loss [W]
- P_{SW_Main} : High-side FET SW loss [W]

High-side FET conduction loss

$$P_{RON_Main} = I_{OMAX}^2 \times \frac{V_o}{V_{IN}} \times R_{ON_Main}$$

- P_{RON_Main} : High-side FET conduction loss [W]
- I_{OMAX} : Maximum load current [A]
- V_{IN} : Power supply voltage of switching system [V]
- V_o : Output voltage [V]
- R_{ON_Main} : High-side FET ON resistance [Ω]

High-side FET SW loss

$$P_{SW_Main} = \frac{V_{IN} \times f_{OSC} \times (I_{btm} \times t_r + I_{top} \times t_f)}{2}$$

- P_{SW_Main} : High-side FET SW loss [W]
- V_{IN} : Power supply voltage of switching system [V]
- f_{OSC} : Oscillation frequency [Hz]
- I_{btm} : Ripple current bottom value of inductor [A]
- I_{top} : Ripple current top value of inductor [A]
- t_r : Turn-on time on high-side FET [s]
- t_f : Turn-off time on high-side FET[s]

Calculate the I_{btm} , the I_{top} , the t_r and the t_f simply by the following formula.

$$I_{btm} = I_{OMAX} - \frac{\Delta IL}{2}$$

$$I_{top} = I_{OMAX} + \frac{\Delta IL}{2}$$

$$t_r = \frac{Q_{gd} \times 4}{5 - V_{gs} (on)} \quad t_f = \frac{Q_{gd} \times 1}{V_{gs} (on)}$$

- I_{OMAX} : Maximum load current [A]
- ΔIL : Ripple current peak-to-peak value of inductor [A]
- Q_{gd} : Quantity of charge between gate and drain on high-side FET [C]
- $V_{gs} (on)$: Voltage between gate and source in Q_{gd} on high-side FET [V]

Calculate the loss on low-side FET by the following formula.

$$P_{\text{SyncFET}} = P_{\text{Ron_Sync}}^* = I_{\text{OMAX}}^2 \times \left(1 - \frac{V_o}{V_{\text{IN}}}\right) \times R_{\text{on_Sync}}$$

- P_{SyncFET} : Low-side FET loss [W]
- $P_{\text{Ron_Sync}}$: Low-side FET conduction loss [W]
- I_{OMAX} : Maximum load current [A]
- V_{IN} : Power supply voltage of switching system [V]
- V_o : Output voltage [V]
- $R_{\text{on_Sync}}$: Low-side FET on-resistance [Ω]

* : The transition voltage of the voltage between drain and source on low-side FET is generally small, and the switching loss is omitted here for the small one as it is possible to disregard it.

The gate drive power of SWFET is supplied by LDO in IC, therefore all SWFET allowable maximum total charge (QgTotalMax) of 2ch is determined by the following formula.

$$Q_{\text{gTotalMax}} \leq \frac{0.095}{f_{\text{osc}}}$$

- $Q_{\text{gTotalMax}}$: SWFET allowable maximum total charge [C]
- f_{osc} : Oscillation frequency [Hz]

Selection of fly-back diode

When the conversion efficiency is valued, the improved property of the conversion efficiency is possible by the addition of the fly-back diode. Though it is usually unnecessary. The effect is achieved in the condition where the oscillation frequency is high or output voltage is lower. Select schottky barrier diode (SBD) that the forward current is as small as possible. In this DC/DC control IC, the period for the electric current flows to fly back diode is limited to synchronous rectification period ($60 \text{ ns} \times 2$) because of using the synchronous rectification method. Therefore, select the one that the electric current of fly back diode doesn't exceed ratings of forward current surge peak (IFSM). Calculate the forward current surge peak ratings of fly back diode by the following formula.

$$I_{\text{FSM}} \geq I_{\text{OMAX}} + \frac{\Delta I_L}{2}$$

- I_{FSM} : Forward current surge peak ratings of fly back diode [A]
- I_{OMAX} : Maximum load current [A]
- ΔI_L : Ripple current peak-to-peak value of inductor [A]

Calculate ratings of the fly-back diode by the following formula:

$$V_{\text{R_Fly}} > V_{\text{IN}}$$

- $V_{\text{R_Fly}}$: Reverse voltage of fly-back diode direct current [V]
- V_{IN} : Power supply voltage of switching system [V]

Selection of output capacitor

This device supports a small ceramic capacitor of the ESR. The ceramic capacitor that is low ESR is an ideal to reduce the ripple voltage compared with other capacitor. Use the tantalum capacitor and the polymer capacitor of the low ESR when a mass capacitor is needed as the ceramic capacitor can not support. To the output voltage, the ripple voltage by the switching operation of DC/DC is generated. Discuss the lower bound of output capacitor value according to an allowable ripple voltage. Calculate the output ripple voltage from the following formula.

$$\Delta V_o = \left(\frac{1}{2\pi \times f_{osc} \times C_o} + ESR \right) \times \Delta I_L$$

ΔV_o	: Switching ripple voltage [V]
ESR	: Series resistance component of output capacitor [Ω]
ΔI_L	: Ripple current peak-to-peak value of inductor [A]
C_o	: Output capacitor value [F]
f_{osc}	: Oscillation frequency [Hz]

- Notes:
- The ripple voltage can be reduced by raising the oscillation frequency and the inductor value besides capacitor.
 - Capacitor has frequency characteristic, the temperature characteristic, and the electrode bias characteristic, etc. The effective capacitor value might become extremely small depending on the condition. Note the effective capacitor value in the condition.

Calculate ratings of the output capacitor by the following formula:

$$V_{co} > V_o$$

V_{co}	: Withstand voltage of the output capacitor [V]
V_o	: Output voltage [V]

Note: Select the capacitor rating with withstand voltage allowing a margin enough for the output voltage.

In addition, use the allowable ripple current with an enough margin, if it has a rating.

Calculate an allowable ripple current of the output capacitor by the following formula:

$$I_{rms} \geq \frac{\Delta I_L}{2\sqrt{3}}$$

I_{rms}	: Allowable ripple current (effective value) [A]
ΔI_L	: Ripple current peak-to-peak value of inductor [A]

Selection of input capacitor

Select the input capacitor whose ESR is as small as possible. The ceramic capacitor is an ideal. Use the tantalum capacitor and the polymer capacitor of the low ESR when a mass capacitor is needed as the ceramic capacitor can not support. To the power supply voltage, the ripple voltage by the switching operation of DC/DC is generated. Discuss the lower bound of input capacitor according to an allowable ripple voltage. Calculate the ripple voltage of the power supply from the following formula.

$$\Delta V_{IN} = \frac{I_{OMAX}}{C_{IN}} \times \frac{V_O}{V_{IN} \times f_{OSC}} + ESR \times \left(I_{OMAX} + \frac{\Delta IL}{2} \right)$$

ΔV_{IN}	: Switching system power supply ripple voltage peak-to-peak value [V]
I_{OMAX}	: Maximum load current value [A]
C_{IN}	: Input capacitor value [F]
V_{IN}	: Power supply voltage of switching system [V]
V_O	: Output setting voltage [V]
f_{OSC}	: Oscillation frequency [Hz]
ESR	: Series resistance component of input capacitor [Ω]
ΔIL	: Ripple current peak-to-peak value of inductor [A]

- Notes:
- The ripple voltage of the power supply can be reduced by raising the oscillation frequency besides capacitor.
 - Capacitor has frequency characteristic, the temperature characteristic, and the electrode bias characteristic, etc. The effective capacitor value might become extremely small depending on the condition. Note the effective capacitor value in the condition.

Calculate ratings of the input capacitor by the following formula:

$$V_{CIN} > V_{IN}$$

V_{CIN}	: Withstand voltage of the input capacitor [V]
V_{IN}	: Power supply voltage of switching system [V]

Note: Select the capacitor rating with withstand voltage with margin enough for the input voltage.

In addition, use the allowable ripple current with an enough margin, if it has a rating.

Calculate an allowable ripple current by the following formula:

$$I_{rms} \geq I_{OMAX} \times \frac{\sqrt{V_O \times (V_{IN} - V_O)}}{V_{IN}}$$

I_{rms}	: Allowable ripple current (effective value) [A]
I_{OMAX}	: Maximum load current value [A]
V_{IN}	: Power supply voltage of switching system [V]
V_O	: Output voltage [V]

Selection of boot strap diode

Select Schottky barrier diode (SBD), that forward current is as small as possible. The electric current that drives the gate of high-side FET flows to SBD of the bootstrap circuit. Calculate the mean current by the following formula. Select it so as not to exceed the electric current ratings.

$$I_D \geq Q_g \times f_{osc}$$

- I_D : Forward current [A]
- Q_g : Total quantity of charge of gate on high-side FET [C]
- f_{osc} : Oscillation frequency [Hz]

Calculate ratings of the boot strap diode by the following formula:

$$V_{R_BOOT} > V_{IN}$$

- V_{R_BOOT} : Reverse voltage of boot strap diode direct current [V]
- V_{IN} : Power supply voltage of switching system [V]

Selection of boot strap capacitor

To drive the gate of high-side FET, the bootstrap capacitor must have enough stored charge. Therefore, a minimum value as a target is assumed the capacitor which can store electric charge 10 times that of the Q_g on high-side FET. And select the boot strap capacitor.

$$C_{BOOT} \geq 10 \times \frac{Q_g}{V_B}$$

- C_{BOOT} : Boot strap capacitor [F]
- Q_g : Amount of gate charge on high-side FET [C]
- V_B : VB voltage [V]

Calculate ratings of the boot strap capacitor by the following formula:

$$V_{CBOOT} > V_B$$

- V_{CBOOT} : Withstand voltage of the boot strap capacitor [V]
- V_B : VB voltage [V]

Design of phase compensation circuit

Assume the phase compensation circuit of 1pole-1zero to be a standard in this device.

1pole-1zero phase compensation circuit

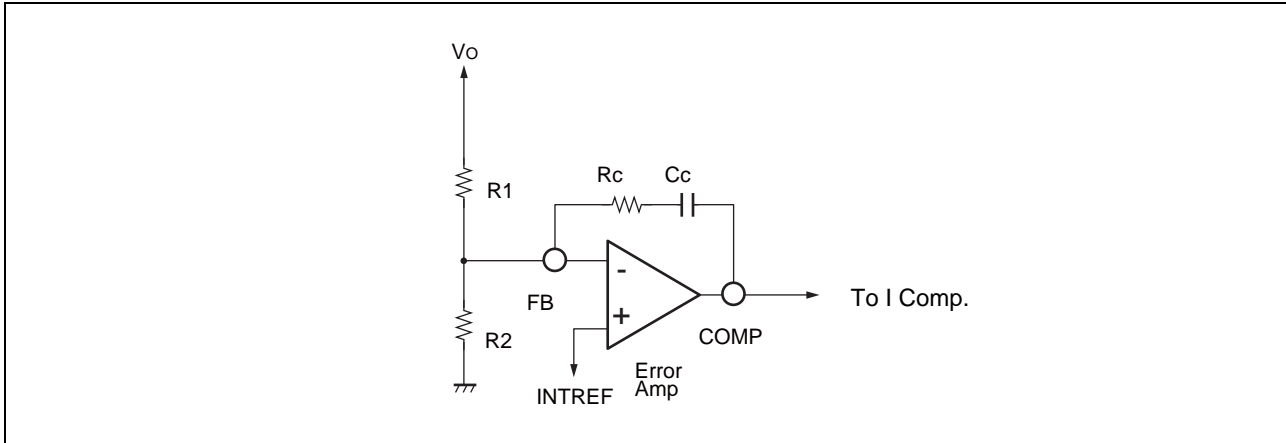

As for crossover frequency (f_{co}) that shows the band width of the control loop of DC/DC. The higher it is, the more excellent the rapid response becomes, however, the possibility of causing the oscillation due to phase margin shortage increases. Though this crossover frequency (f_{co}) can be arbitrarily set, make 1/10 of the oscillation frequencies (f_{osc}) a standard, and set it to the upper limit. Moreover, set the phase margin at least to 30 °C, and 45 °C or more if possible as a reference.

Set the constants of R_c and C_c of the phase compensation circuit using the following formula as a target.

$$R_c = \frac{(V_{IN} - V_o) A_{LVCNV} \times R_{ON_Main} \times f_{co} \times 2\pi \times C_o \times V_o}{V_{IN} \times f_{osc} \times L \times I_{OMAX}} \times R_1$$

$$C_c = \frac{C_o \times V_o}{R_c \times I_{OMAX}}$$

- R_c : Phase compensation resistor value [Ω]
- C_c : Phase compensation capacitor value [F]
- V_{IN} : Power supply voltage of switching system [V]
- V_o : Output setting voltage [V]
- f_{osc} : Oscillation frequency [Hz]
- I_{OMAX} : Maximum load current value [A]
- L : Inductor value [H]
- C_o : Output capacitor value [F]
- R_{ON_Main} : High-side FET ON resistance [Ω]
- R_1 : Output setting resistor value [Ω]
- A_{LVCNV} : Level converter voltage gain [V/V]
 - On-duty \leq 50% : $A_{LVCNV} = 6.8$
 - On-duty $>$ 50% : $A_{LVCNV} = 13.6$
- f_{co} : Cross-over frequency (arbitrary setting) [Hz]

VB pin capacitor

2.2 μF is assumed to be a standard, and when Q_g of SWFET used is large, it is necessary to adjust it. To drive the gate of high-side FET, the bootstrap capacitor must have enough stored charge. Therefore, a minimum value as a target is assumed the capacitor, which can store electric charge 100 times that of the Q_g of the SWFET. And select it.

$$C_{VB} \geq 100 \times \frac{Q_g}{V_B}$$

- C_{VB} : VB pin capacitor value [F]
- Q_g : Total amount of gate charge of 2 ch respectively: high-side FET and low-side FET [C]
- V_B : VB voltage [V]

Calculate ratings of the VB pin capacitor by the following formula:

$$V_{CVB} > V_B$$

- V_{CVB} : Withstand voltage of the VB pin capacitor [V]
- V_B : VB voltage [V]

VB regulator

In the condition for which the potential difference between VCC and VB is insufficient, the decrease in the voltage of VB happens because of power output on-resistance and load current (mean current of all external FET gate driving current and load current of internal IC) of the VB regulator. Stop the switching operation when the voltage of VB decreases and it reaches threshold voltage (V_{THL1}) of the under voltage lockout protection circuit. Therefore, set oscillation frequency or external FET or I/O potential difference of the VB regulator using the following formula as a target when you use this IC.

$$V_{CC} \geq V_{B(V_{THL1})} + (Q_g \times f_{osc} + I_{CC}) \times R_{VB}$$

- V_{CC} : Power supply voltage [V] (V_{IN})
- $V_{B(V_{THL1})}$: Threshold voltage of VB under-voltage lockout protection circuit [V]
(3.8 [V] Max)
- Q_g : Total amount of gate charge of 2 ch respectively: high-side FET and low-side FET [C]
- f_{osc} : Oscillation frequency [Hz]
- I_{CC} : Power supply current [A] (4.7×10^{-3} [A] \neq Load current of VB (LDO))
- R_{VB} : VB output on-resistance [Ω] (100 Ω (The reference value at $V_{CC} = 4.5$ V))

If the I/O potential difference is small, the problem can be solved by connecting the VB pin and the VCC pin. The conditions of the input voltage range are as follows:

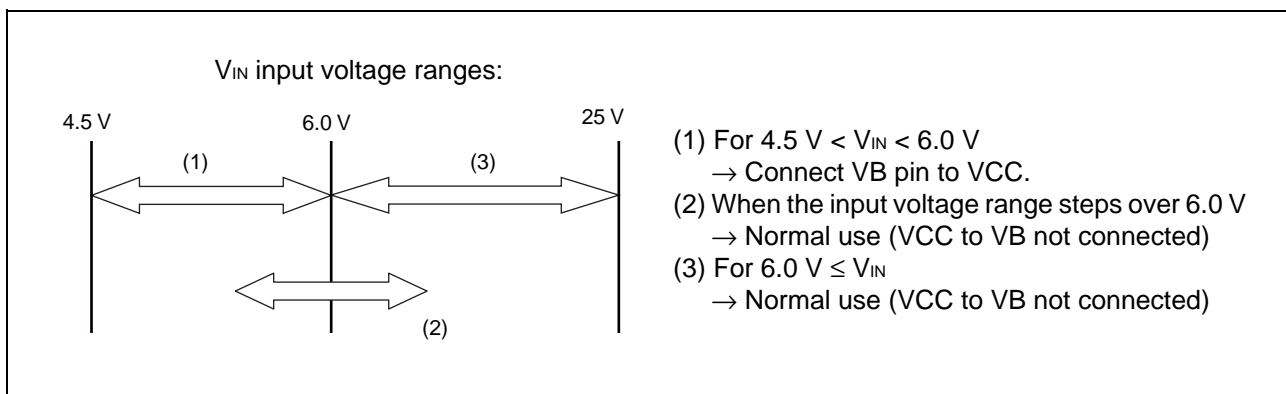

Note that if the I/O potential difference is not enough when used, use the actual machine to check carefully the operations at the normal operation, start operation, and stop operation. In particular, care is needed when the input voltage range over 6 V.

Power dissipation and the thermal design

As for this IC, considerations of the power dissipation and thermal design are not necessary in most cases because of its high efficiency. However, they are necessary for the use at the conditions of a high power supply voltage, a high oscillation frequency, high load, and the high temperature.

Calculate IC internal loss (P_{IC}) by the following formula.

$$P_{IC} = V_{CC} \times (I_{CC} + Q_g \times f_{osc})$$

- P_{IC} : IC internal loss [W]
- V_{CC} : Power supply voltage (V_{IN}) [V]
- I_{CC} : Power supply current [A] (4.7 [mA] Max)
- Q_g : All SWFET total quantity of charge for ch 2 [C] (Total with $V_{gs} = 5$ V)
- f_{osc} : Oscillation frequency[Hz]

Calculate junction temperature (T_j) by the following formula.

$$T_j = T_a + \theta_{ja} \times P_{IC}$$

- T_j : Junction temperature [°C] (+150 [°C] Max)
- T_a : Ambient temperature [°C]
- θ_{ja} : TSSOP-24 Package thermal resistance (76 °C/W)
- P_{IC} : IC internal loss [W]

Handling of the pins when using a single channel

Although this device is a 2-channel DC/DC converter control IC, it is also able to be used as a 1-channel DC/DC converter by handling the pins of the unused channel as shown in the following diagram.

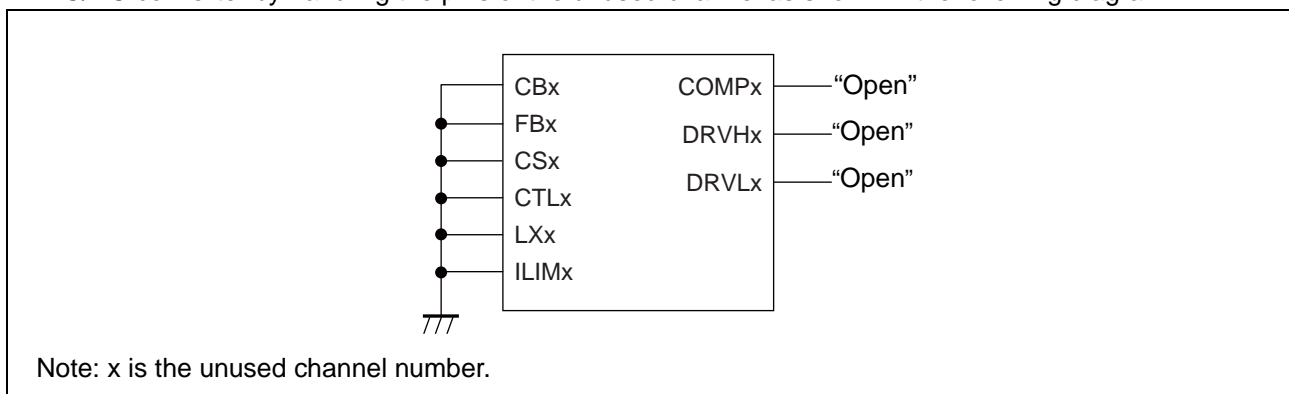

Board layout

Consider the points listed below and do the layout design.

- Provide the ground plane as much as possible on the IC mounted face. Connect bypass capacitor connected with the VCC and VB pins, and GND pin of the switching system parts with switching system GND (PGND). Connect other GND connection pins with control system GND (AGND), and separate each GND, and try not to pass the heavy current path through the control system GND (AGND) as much as possible. In that case, connect control system GND (AGND) and switching system GND (PGND) right under IC.
- Connect the switching system parts as much as possible on the surface. Avoid the connection through the through-hole as much as possible.
- As for GND pins of the switching system parts, provide the through hole at the proximal place, and connect it with GND of internal layer.
- Pay the most attention to the loop composed of input capacitor (C_{IN}), SWFET, and fly-back diode (SBD). Consider making the current loop as small as possible.
- Place the boot strap capacitor (C_{BOOT1} , C_{BOOT2}) proximal to CBx and LXx pins of IC as much as possible.
- This device monitors the voltage between drain and source on high-side FET as voltage between VCC and LX pins. Place the input capacitor (C_{IN}) and the high-side FET of each CH proximally as much as possible. Draw out the wiring to VCC pin from the proximal place to the input capacitor of CH1 and CH2. As for the net of the LXx pin, draw it out from the proximal place to the source pin on high-side FET. Moreover, a large electric current flows momentary in the net of the LXx pin. Wire the linewidth of about 0.8mm to be a standard, as short as possible.
- Large electric current flows momentary in the net of DRVHx and DRVLx pins connected with the gate of SWFET. Wire the linewidth of about 0.8mm to be a standard, as short as possible.
- By-pass capacitor (C_{VCC} , C_{VREF} , C_{VB}) connected with VREF, VCC, and VB, and the resistor (R_{RT}) connected with the RT pin should be placed close to the pin as much as possible. Also connect the GND pin of the by-pass capacitor with GND of internal layer in the proximal through-hole.
- Consider the net connected with RT, FBx, and the COMPx pins to keep away from a Switching system parts as much as possible because it is sensitive to the noise. Moreover, place the output voltage setting resistor and the phase compensation circuit element connected with this net close to the IC as much as possible, and try to make the net as short as possible. In addition, for the internal layer right under the installing part, provide the control system GND (AGND) of few ripple and few spike noises, or provide the ground plane of the power supply voltage as much as possible.

Switching system parts : Input capacitor (C_{IN}), SWFET, Fly-back diode (SBD), Inductor (L), Output capacitor (C_o)

Note: x : Each channel number

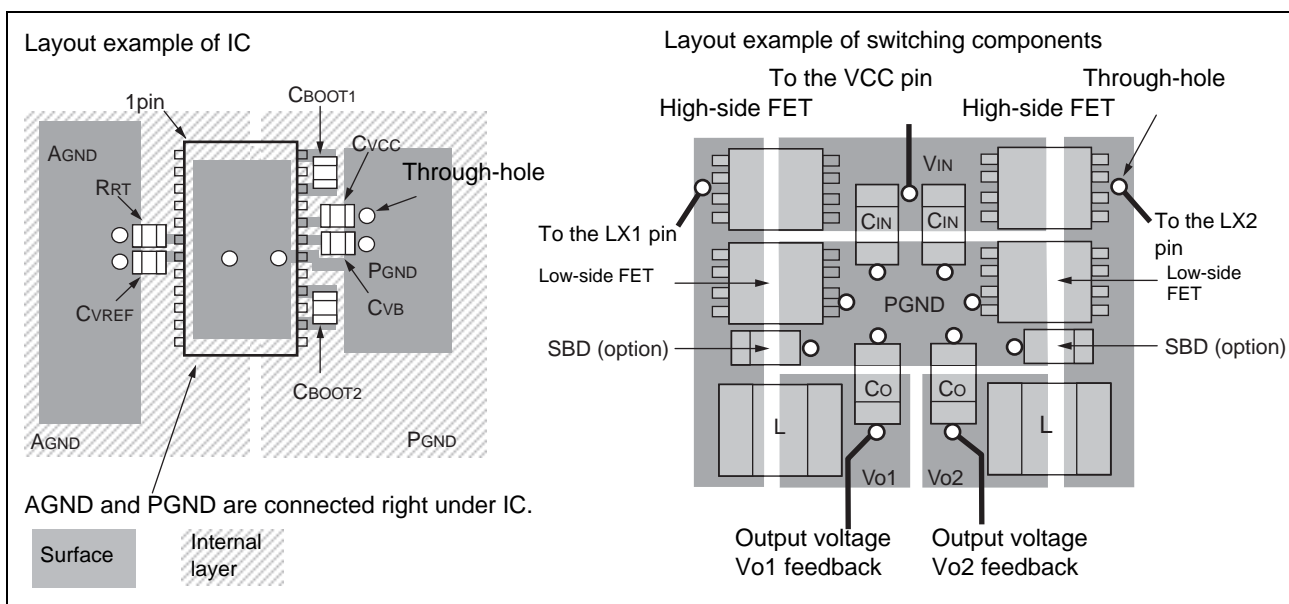

REFERENCE DATA

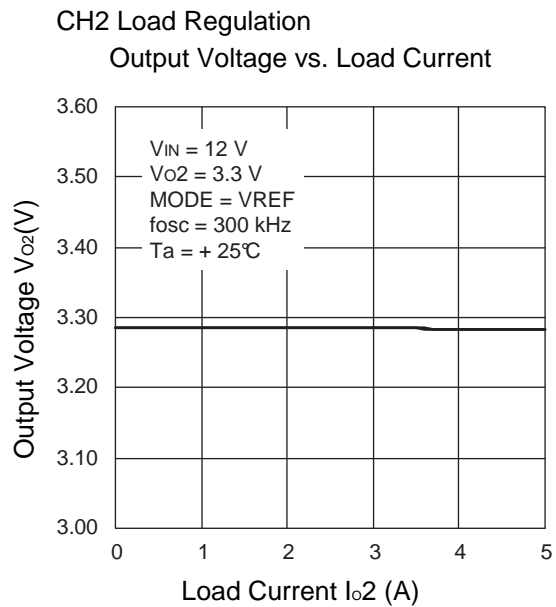
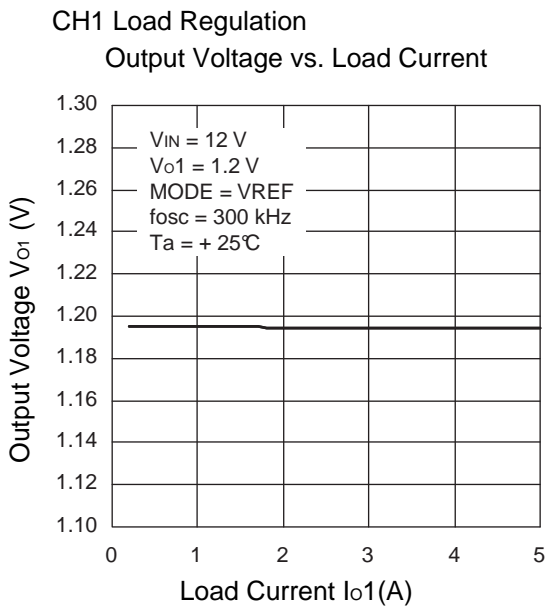
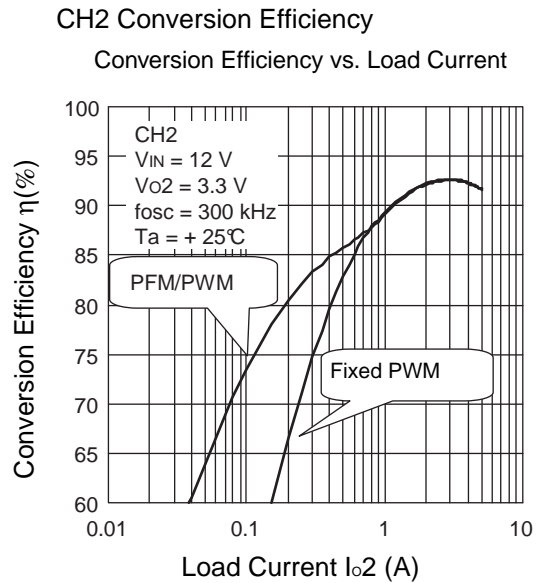
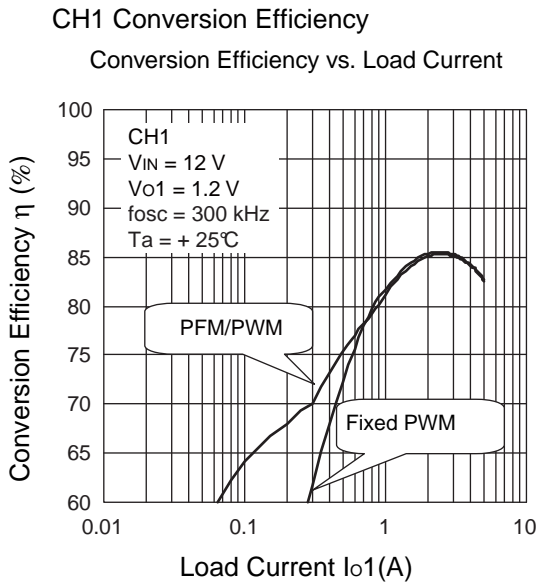

(Continued)

(Continued)

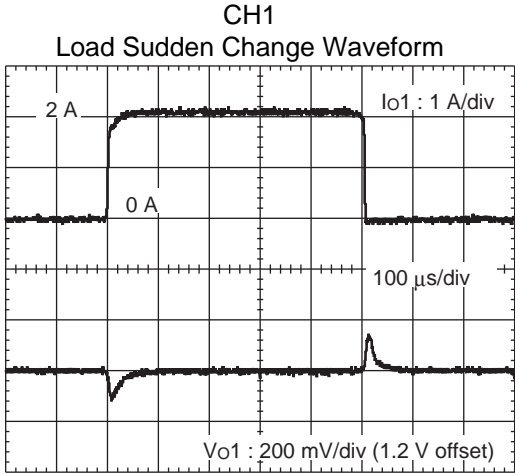

$V_{IN} = 12\text{ V}$, $V_{o1} = 1.2\text{ V}$
 $I_{o1} = 0 \leftarrow \rightarrow 2\text{ A}$, $f_{osc} = 300\text{ kHz}$, $T_a = +25\text{ }^\circ\text{C}$

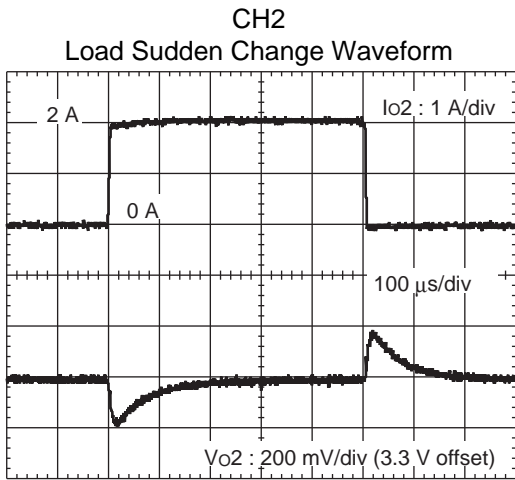

$V_{IN} = 12\text{ V}$, $V_{o2} = 3.3\text{ V}$
 $I_{o2} = 0 \leftarrow \rightarrow 2\text{ A}$, $f_{osc} = 300\text{ kHz}$, $T_a = +25\text{ }^\circ\text{C}$

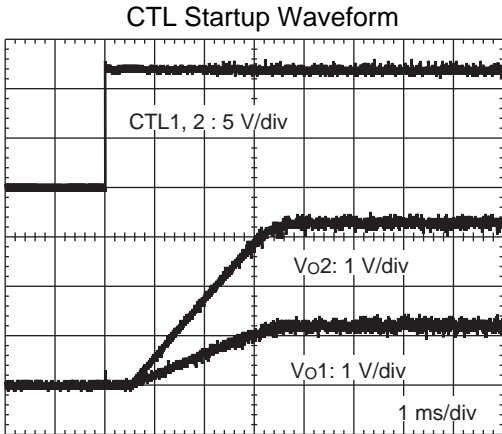

$V_{IN} = 12\text{ V}$, $f_{osc} = 300\text{ kHz}$, $T_a = +25\text{ }^\circ\text{C}$, Soft-start setting time = 3.0 ms
 $V_{o1} = 1.2\text{ V}$, $I_{o1} = 5\text{ A}$ (0.24 Ω), $V_{o2} = 3.3\text{ V}$, $I_{o2} = 5\text{ A}$ (0.66 Ω)

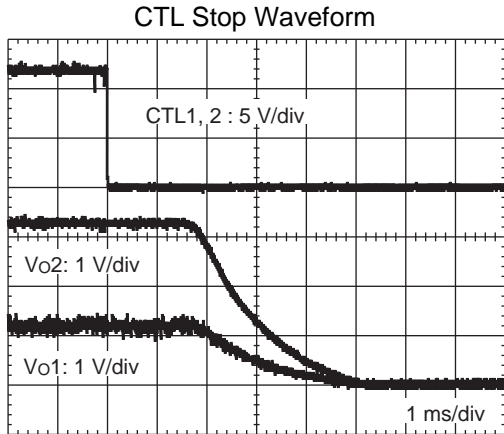

Normal operation → Over current protection → Under voltage protection operation waveform

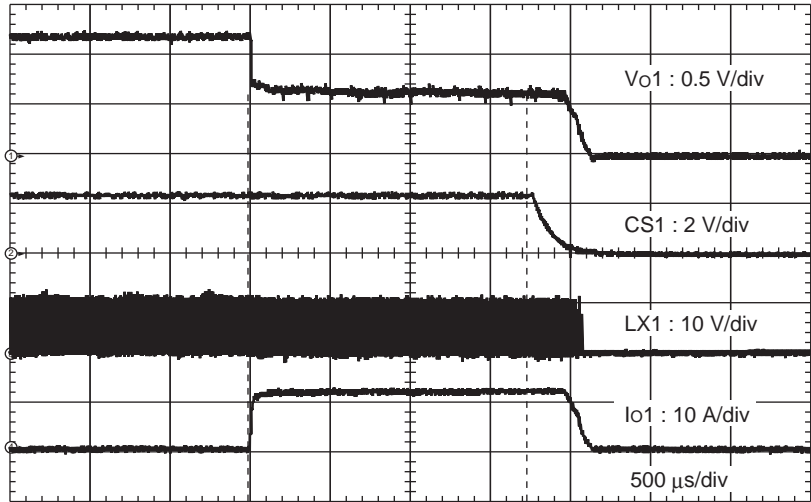

$V_{IN} = 12\text{ V}$
 $V_{o1} = 1.2\text{ V}$
 $f_{osc} = 300\text{ kHz}$
 $T_a = +25\text{ }^\circ\text{C}$

Normal operation Over current protection operation Under voltage protection operation

■ USAGE PRECAUTION

1. Do not configure the IC over the maximum ratings.

If the IC is used over the maximum ratings, the LSI may be permanently damaged.

It is preferable for the device to be normally operated within the recommended usage conditions. Usage outside of these conditions can have an adverse effect on the reliability of the LSI.

2. Use the device within the recommended operating conditions.

The recommended values guarantee the normal LSI operation under the recommended operating conditions. The electrical ratings are guaranteed when the device is used within the recommended operating conditions and under the conditions stated for each item.

3. Printed circuit board ground lines should be set up with consideration for common impedance.

4. Take appropriate measures against static electricity.

- Containers for semiconductor materials should have anti-static protection or be made of conductive material.
- After mounting, printed circuit boards should be stored and shipped in conductive bags or containers.
- Work platforms, tools, and instruments should be properly grounded.
- Working personnel should be grounded with resistance of 250 k Ω to 1 M Ω in series between body and ground.

5. Do not apply negative voltages.

The use of negative voltages below -0.3 V may make the parasitic transistor activated, and can cause malfunctions.

■ ORDERING INFORMATION

Part number	Package	Remarks
MB39A136PFT	24-pin plastic TSSOP (FPT-24P-M09)	

■ EV BOARD ORDERING INFORMATION

Part number	EV board version No.	Remarks
MB39A136EVB-01	MB39A136EVB-01 Rev2.0	TSSOP-24

■ RoHS COMPLIANCE INFORMATION OF LEAD (Pb) FREE VERSION

The LSI products of FUJITSU SEMICONDUCTOR with “E1” are compliant with RoHS Directive, and has observed the standard of lead, cadmium, mercury, Hexavalent chromium, polybrominated biphenyls (PBB), and polybrominated diphenyl ethers (PBDE). A product whose part number has trailing characters “E1” is RoHS compliant.

■ MARKING FORMAT (Lead Free version)

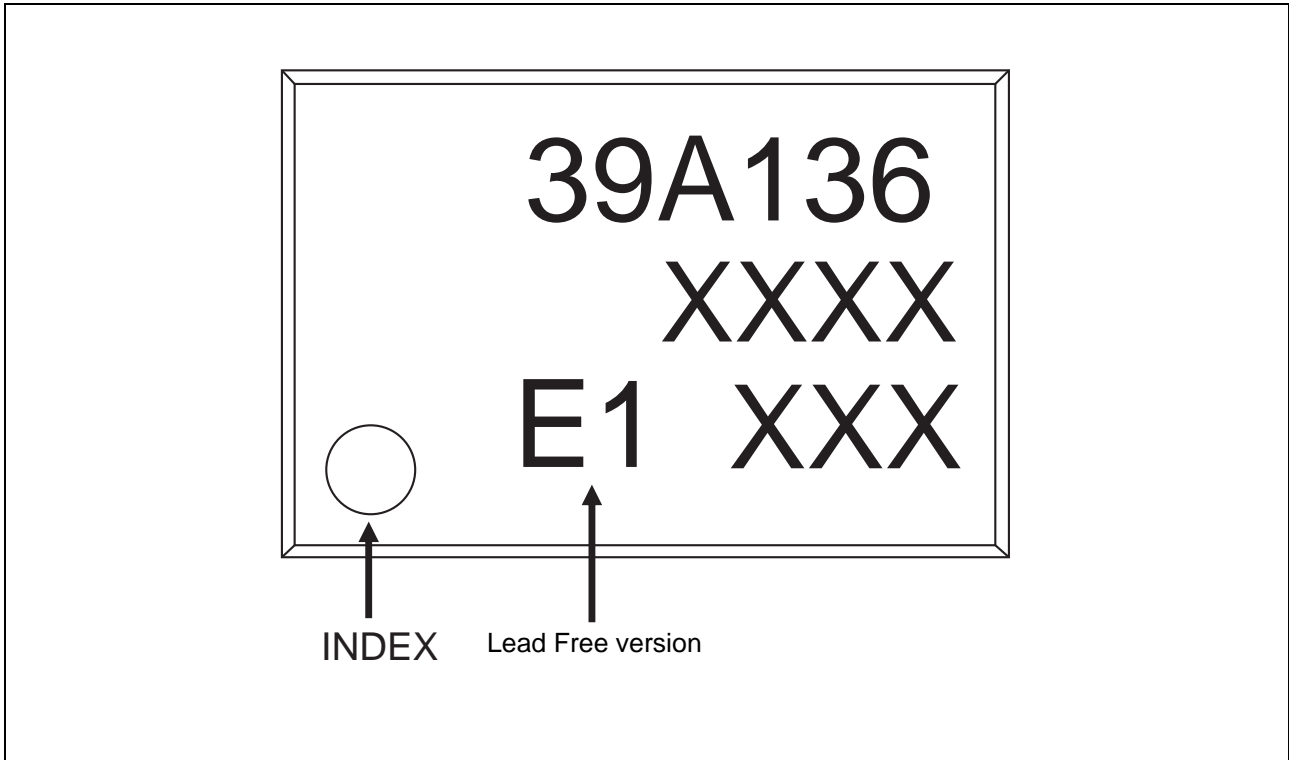

■ LABELING SAMPLE (Lead free version)

Lead-free mark

JEITA logo

JEDEC logo

MB123456P - 789 - GE1
(3N) 1MB123456P-789-GE1 1000
QC PASS

(3N)2 1561190005 107210
1,000 PCS
MB123456P - 789 - GE1

2006/03/01 ASSEMBLED IN JAPAN

MB123456P - 789 - GE1
1561190005 1/1 0605 - Z01A 1000

The part number of a lead-free product has the trailing characters "E1".

"ASSEMBLED IN CHINA" is printed on the label of a product assembled in China.

MB39A136

■ MB39A136PFT RECOMMENDED CONDITIONS OF MOISTURE SENSITIVITY LEVEL

[FUJITSU SEMICONDUCTOR Recommended Mounting Conditions]

Item	Condition	
Mounting Method	IR (infrared reflow) , Manual soldering (partial heating method)	
Mounting times	2 times	
Storage period	Before opening	Please use it within two years after Manufacture.
	From opening to the 2nd reflow	Less than 8 days
	When the storage period after opening was exceeded	Please process within 8 days after baking (125 °C, 24h)
Storage conditions	5 °C to 30 °C, 70%RH or less (the lowest possible humidity)	

[Mounting Conditions]

(1) IR (infrared reflow)

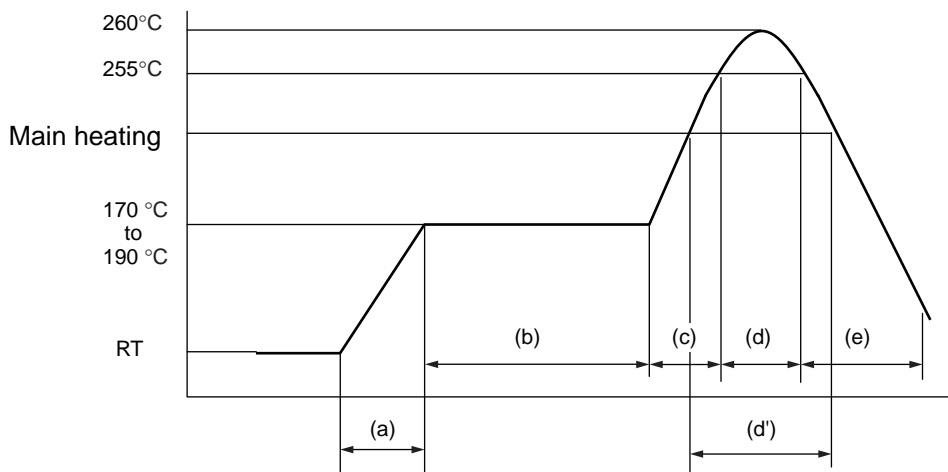

“H” level : 260 °C Max

- (a) Temperature increase gradient : Average 1 °C/s to 4 °C/s
- (b) Preliminary heating : Temperature 170 °C to 190 °C, 60 s to 180 s
- (c) Temperature increase gradient : Average 1 °C/s to 4 °C/s
- (d) Peak temperature : Temperature 260 °C Max; 255 °C or more, 10 s or less
- (d') Main heating : Temperature 230 °C or more, 40 s or less
or
Temperature 225 °C or more, 60 s or less
or
Temperature 220 °C or more, 80 s or less
- (e) Cooling : Natural cooling or forced cooling

Note: Temperature : on the top of the package body

(2) Manual soldering (partial heating method)

Temperature at the tip of a soldering iron: 400 °C max
Time: Five seconds or below per pin

PACKAGE DIMENSIONS

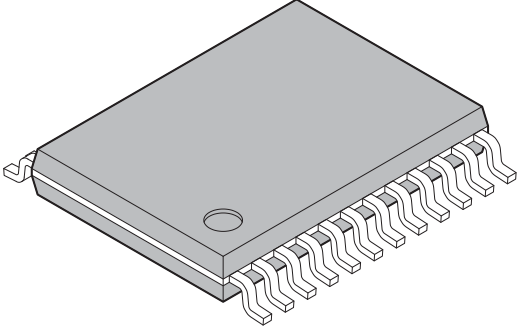
<p>24-pin plastic TSSOP</p>  <p>(FPT-24P-M09)</p>	Lead pitch	0.50 mm
	Package width × package length	4.40 mm × 6.50 mm
	Lead shape	Gullwing
	Sealing method	Plastic mold
	Mounting height	1.20 mm MAX
	Weight	0.08 g

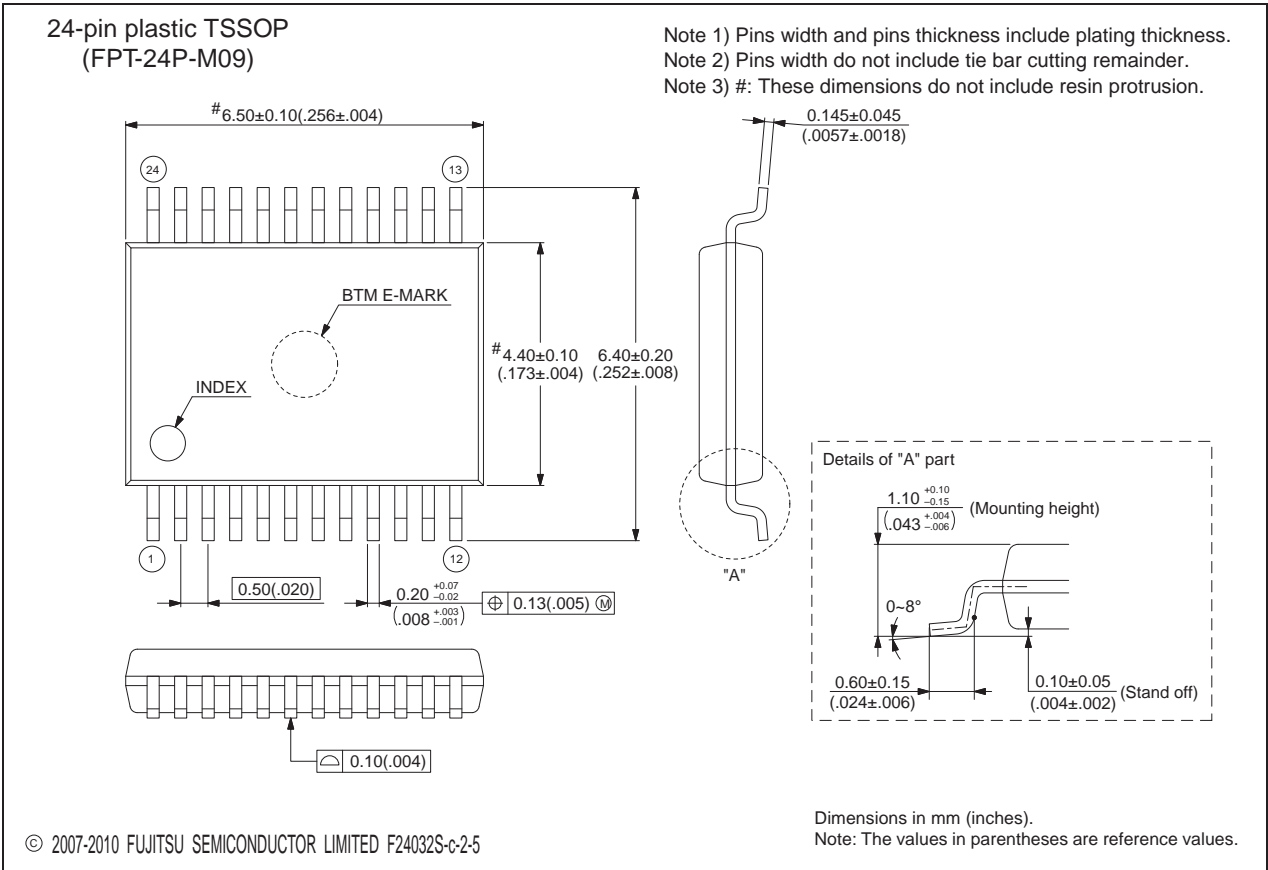

Please check the latest package dimension at the following URL.
<http://edevice.fujitsu.com/package/en-search/>

■ MAJOR CHANGES IN THIS EDITION

A change on a page is indicated by a vertical line drawn on the left side of that page.

Page	Section	Change Results
9	■ ELECTRICAL CHARACTERISTICS	Revised the minimum value of “Maximum on-duty” in “Output Block [DRV]”: 72 → 75

■ CONTENTS

	page
- DESCRIPTION	1
- FEATURES	1
- APPLICATION	1
- PIN ASSIGNMENT	2
- PIN DESCRIPTION	3
- BLOCK DIAGRAM	4
- ABSOLUTE MAXIMUM RATINGS	5
- RECOMMENDED OPERATING CONDITIONS	6
- ELECTRICAL CHARACTERISTICS	7
- TYPICAL CHARACTERISTICS	11
- FUNCTION DESCRIPTION	13
- PROTECTION FUNCTION TABLE	17
- I/O PIN EQUIVALENT CIRCUIT DIAGRAM	18
- EXAMPLE APPLICATION CIRCUIT	20
- PARTS LIST	21
- APPLICATION NOTE	23
- REFERENCE DATA	40
- USAGE PRECAUTION	42
- ORDERING INFORMATION	43
- EV BOARD ORDERING INFORMATION	43
- RoHS COMPLIANCE INFORMATION OF LEAD (Pb) FREE VERSION	44
- MARKING FORMAT (Lead Free version)	44
- LABELING SAMPLE (Lead free version)	45
- MB39A136PFT RECOMMENDED CONDITIONS OF MOISTURE SENSITIVITY LEVEL	46
- PACKAGE DIMENSIONS	47
- MAJOR CHANGES IN THIS EDITION	48

MEMO

MEMO

FUJITSU SEMICONDUCTOR LIMITED

Nomura Fudosan Shin-yokohama Bldg. 10-23, Shin-yokohama 2-Chome,
Kohoku-ku Yokohama Kanagawa 222-0033, Japan

Tel: +81-45-415-5858

<http://jp.fujitsu.com/fsl/en/>

For further information please contact:

North and South America

FUJITSU SEMICONDUCTOR AMERICA, INC.

1250 E. Arques Avenue, M/S 333

Sunnyvale, CA 94085-5401, U.S.A.

Tel: +1-408-737-5600 Fax: +1-408-737-5999

<http://us.fujitsu.com/micro/>

Asia Pacific

FUJITSU SEMICONDUCTOR ASIA PTE. LTD.

151 Lorong Chuan,

#05-08 New Tech Park 556741 Singapore

Tel : +65-6281-0770 Fax : +65-6281-0220

<http://sg.fujitsu.com/semiconductor/>

Europe

FUJITSU SEMICONDUCTOR EUROPE GmbH

Pittlerstrasse 47, 63225 Langen, Germany

Tel: +49-6103-690-0 Fax: +49-6103-690-122

<http://emea.fujitsu.com/semiconductor/>

FUJITSU SEMICONDUCTOR SHANGHAI CO., LTD.

30F, Kerry Parkside, 1155 Fang Dian Road, Pudong District,

Shanghai 201204, China

Tel : +86-21-6146-3688 Fax : +86-21-6146-3660

<http://cn.fujitsu.com/fss/>

Korea

FUJITSU SEMICONDUCTOR KOREA LTD.

902 Kosmo Tower Building, 1002 Daechi-Dong,

Gangnam-Gu, Seoul 135-280, Republic of Korea

Tel: +82-2-3484-7100 Fax: +82-2-3484-7111

<http://kr.fujitsu.com/fsk/>

FUJITSU SEMICONDUCTOR PACIFIC ASIA LTD.

2/F, Green 18 Building, Hong Kong Science Park,

Shatin, N.T., Hong Kong

Tel : +852-2736-3232 Fax : +852-2314-4207

<http://cn.fujitsu.com/fsp/>

Specifications are subject to change without notice. For further information please contact each office.

All Rights Reserved.

The contents of this document are subject to change without notice.

Customers are advised to consult with sales representatives before ordering.

The information, such as descriptions of function and application circuit examples, in this document are presented solely for the purpose of reference to show examples of operations and uses of FUJITSU SEMICONDUCTOR device; FUJITSU SEMICONDUCTOR does not warrant proper operation of the device with respect to use based on such information. When you develop equipment incorporating the device based on such information, you must assume any responsibility arising out of such use of the information.

FUJITSU SEMICONDUCTOR assumes no liability for any damages whatsoever arising out of the use of the information.

Any information in this document, including descriptions of function and schematic diagrams, shall not be construed as license of the use or exercise of any intellectual property right, such as patent right or copyright, or any other right of FUJITSU SEMICONDUCTOR or any third party or does FUJITSU SEMICONDUCTOR warrant non-infringement of any third-party's intellectual property right or other right by using such information. FUJITSU SEMICONDUCTOR assumes no liability for any infringement of the intellectual property rights or other rights of third parties which would result from the use of information contained herein.

The products described in this document are designed, developed and manufactured as contemplated for general use, including without limitation, ordinary industrial use, general office use, personal use, and household use, but are not designed, developed and manufactured as contemplated (1) for use accompanying fatal risks or dangers that, unless extremely high safety is secured, could have a serious effect to the public, and could lead directly to death, personal injury, severe physical damage or other loss (i.e., nuclear reaction control in nuclear facility, aircraft flight control, air traffic control, mass transport control, medical life support system, missile launch control in weapon system), or (2) for use requiring extremely high reliability (i.e., submersible repeater and artificial satellite).

Please note that FUJITSU SEMICONDUCTOR will not be liable against you and/or any third party for any claims or damages arising in connection with above-mentioned uses of the products.

Any semiconductor devices have an inherent chance of failure. You must protect against injury, damage or loss from such failures by incorporating safety design measures into your facility and equipment such as redundancy, fire protection, and prevention of over-current levels and other abnormal operating conditions.

Exportation/release of any products described in this document may require necessary procedures in accordance with the regulations of the Foreign Exchange and Foreign Trade Control Law of Japan and/or US export control laws.

The company names and brand names herein are the trademarks or registered trademarks of their respective owners.

Edited: Sales Promotion Department