

ASSP For Power Supply Applications (General-Purpose DC/DC Converter)

3-ch DC/DC Converter IC

MB39A112

■ DESCRIPTION

The MB39A112 is a 3-channel DC/DC converter IC using pulse width modulation (PWM), and the MB39A112 is suitable for down-conversion.

3-channel is built in TSSOP-20P package. Each channel can be controlled and soft-start.

The MB39A112 contains a constant voltage bias circuit for output block, capable of implementing an efficient high-frequency DC/DC converter. It is ideal for built-in power supply such as ADSL modems.

■ FEATURES

- Supports for down-conversion (CH1 to CH3)
- Power supply voltage range : 7 V to 25 V
- Error amplifier threshold voltage : 1.00 V \pm 1% (CH1)
: 1.23 V \pm 1% (CH2, CH3)
- Oscillation frequency range : 250 kHz to 2.6 MHz
- Built-in soft-start circuit independent of loads
- Built-in timer-latch short-circuit protection circuit
- Built-in totem-pole type output for P-channel MOS FET devices
- Built-in constant voltage (VCCO – 5 V) bias circuit for output block

■ PACKAGE

20-pin plastic TSSOP

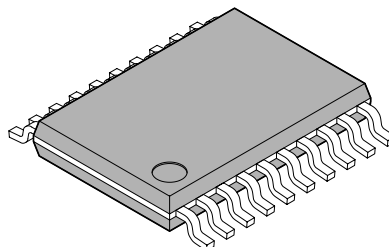

(FPT-20P-M06)

MB39A112

■ PIN ASSIGNMENT

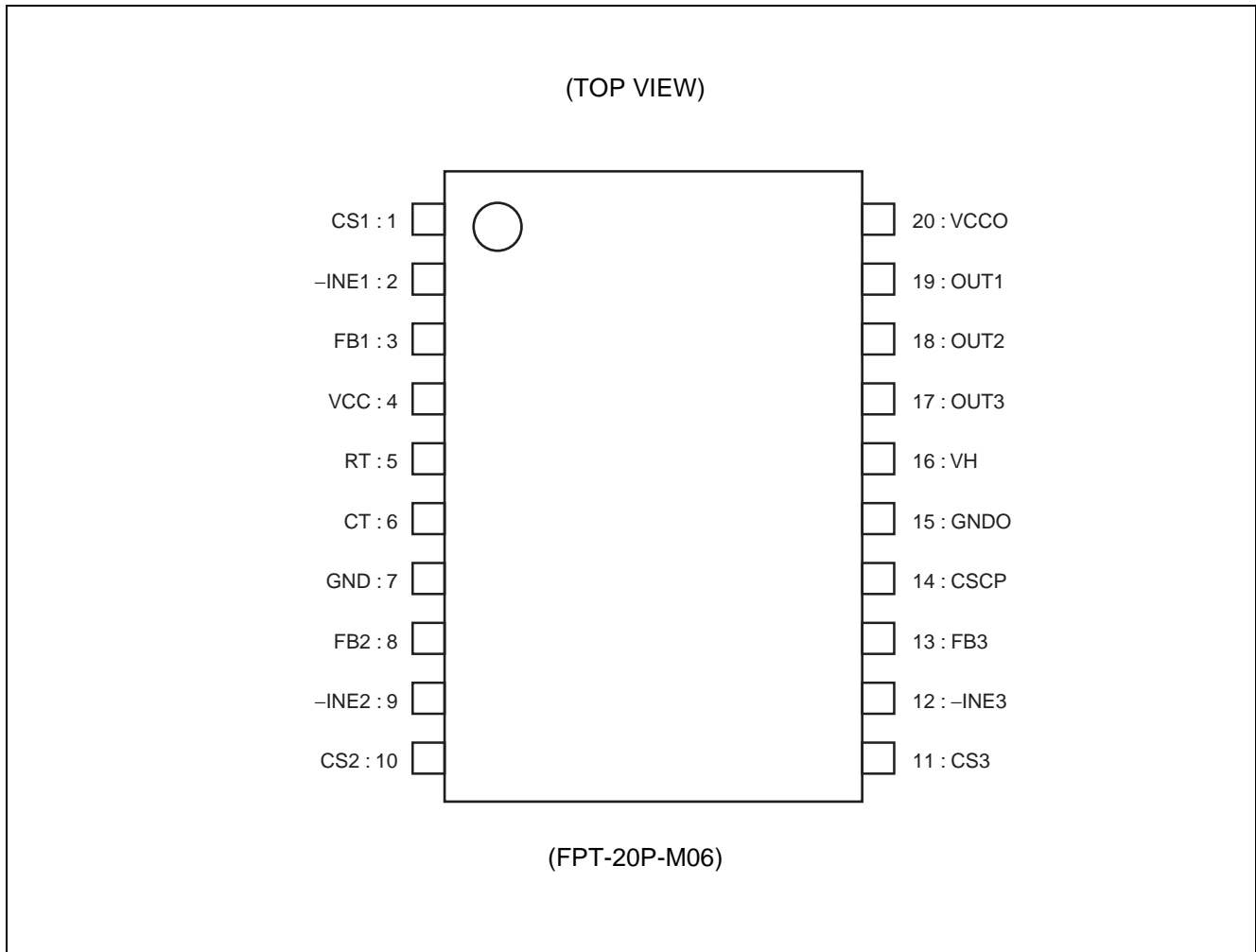

■ PIN DESCRIPTION

Pin No.	Symbol	I/O	Descriptions
1	CS1	—	CH1 soft-start setting capacitor connection terminal.
2	- INE1	I	CH1 error amplifier inverted input terminal.
3	FB1	O	CH1 error amplifier output terminal.
4	VCC	—	Control circuit power supply terminal.
5	RT	—	Triangular-wave oscillation frequency setting resistor connection terminal.
6	CT	—	Triangular-wave oscillation frequency setting capacitor connection terminal.
7	GND	—	Ground terminal.
8	FB2	O	CH2 error amplifier output terminal.
9	- INE2	I	CH2 error amplifier inverted input terminal.
10	CS2	—	CH2 soft-start setting capacitor connection terminal.
11	CS3	—	CH3 soft-start setting capacitor connection terminal.
12	- INE3	I	CH3 error amplifier inverted input terminal.
13	FB3	O	CH3 error amplifier output terminal.
14	CSCP	—	Timer-latch short-circuit protection capacitor connection terminal.
15	GND0	—	Ground terminal.
16	VH	O	Power supply terminal for driving output circuit. (VH = VCCO - 5 V) .
17	OUT3	O	CH3 external Pch MOS FET gate driving terminal.
18	OUT2	O	CH2 external Pch MOS FET gate driving terminal.
19	OUT1	O	CH1 external Pch MOS FET gate driving terminal.
20	VCCO	—	Power supply terminal for driving output circuit. (Connect to same potential as VCC terminal).

MB39A112

■ BLOCK DIAGRAM

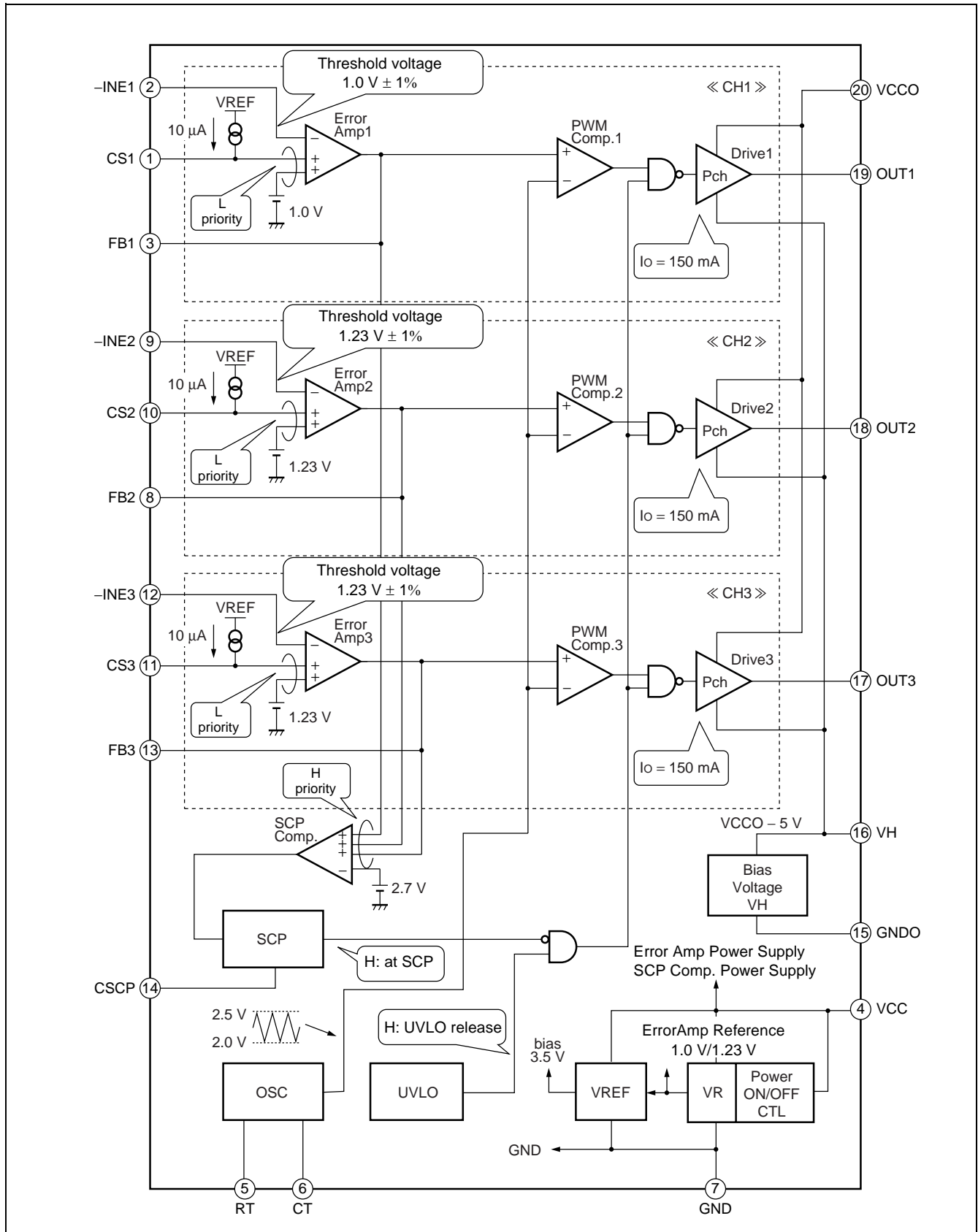

■ ABSOLUTE MAXIMUM RATINGS

Parameter	Symbol	Conditions	Rating		Unit
			Min	Max	
Power supply voltage	V _{CC}	VCC, VCCO terminal	—	28	V
Output current	I _O	OUT1, OUT2, OUT3 terminal	—	20	mA
Peak output current	I _{OP}	Duty ≤ 5 % (t = 1/fosc × Duty)	—	400	mA
Power dissipation	P _D	T _a ≤ + 25 °C	—	1280*	mW
Storage temperature	T _{STG}	—	– 55	+ 125	°C

* : The package is mounted on the dual-sided epoxy board (10 cm × 10 cm) .

WARNING: Semiconductor devices can be permanently damaged by application of stress (voltage, current, temperature, etc.) in excess of absolute maximum ratings. Do not exceed these ratings.

■ RECOMMENDED OPERATING CONDITIONS

Parameter	Symbol	Conditions	Value			Unit
			Min	Typ	Max	
Power supply voltage	V _{CC}	VCC, VCCO terminal	7	12	25	V
Input voltage	V _{IN}	– INE terminal	0	—	V _{CC} – 1.8	V
Output current	I _O	OUT1, OUT2, OUT3 terminal	– 15	—	15	mA
	I _{VH}	VH terminal	0	—	30	mA
Oscillation frequency	fosc	—	250	1200	2600	kHz
Timing capacitor	C _T	—	22	100	1000	pF
Timing resistor	R _T	—	4.7	10	22	kΩ
VH terminal capacitor	C _{VH}	VH terminal	—	0.1	1.0	μF
Soft-start capacitor	C _S	CS1, CS2, CS3 terminal	—	0.1	1.0	μF
Short-circuit detection capacitor	C _{SCP}	CSCP terminal	—	0.01	1.0	μF
Operating ambient temperature	T _a	—	– 30	+ 25	+ 85	°C

WARNING: The recommended operating conditions are required in order to ensure the normal operation of the semiconductor device. All of the device's electrical characteristics are warranted when the device is operated within these ranges.

Always use semiconductor devices within their recommended operating condition ranges. Operation outside these ranges may adversely affect reliability and could result in device failure.

No warranty is made with respect to uses, operating conditions, or combinations not represented on the data sheet. Users considering application outside the listed conditions are advised to contact their representatives beforehand.

MB39A112

■ ELECTRICAL CHARACTERISTICS

(VCC = VCCO = 12 V, Ta = + 25 °C)

Parameter		Sym- bol	Pin No.	Conditions	Value			Unit
					Min	Typ	Max	
Undervoltage Lockout Protection Circuit Block [UVLO]	Threshold voltage	V _{TH}	4	VCC = $\sqrt{\quad}$	6.35	6.55	6.75	V
	Hysteresis width	V _{HYS}	4	—	—	0.15	—	V
Short-circuit Protection Circuit Block [SCP]	Threshold voltage	V _{TH}	14	—	0.67	0.72	0.77	V
	Input source current	I _{CSCP}	14	—	- 1.4	- 1.0	- 0.6	μA
	Reset voltage	V _{RST}	4	VCC = ∇	6.2	6.4	6.6	V
Triangular Wave Oscillator Block [OSC]	Oscillation frequency	f _{OSC}	17 to 19	CT = 100 pF, RT = 10 kΩ	1080	1200	1320	kHz
Soft-start Block [CS1, CS2, CS3]	Charge current	I _{CS}	1, 10, 11	—	- 14	- 10	- 6	μA
Error Amp Block (CH1) [Error Amp1]	Threshold voltage	V _{TH}	2	FB1 = 2.25 V	0.99	1.00	1.01	V
	Input bias current	I _B	2	- INE1 = 0 V	- 250	- 63	—	nA
	Voltage gain	A _V	3	DC	60	100	—	dB
	Frequency band width	B _W	3	A _V = 0dB	—	1.5*	—	MHz
	Output voltage	V _{OH}	3	—	3.2	3.4	—	V
		V _{OL}	3	—	—	40	200	mV
	Output source current	I _{SOURCE}	3	FB1 = 2.25 V	—	- 2	- 1	mA
	Output sink current	I _{SINK}	3	FB1 = 2.25 V	150	250	—	μA
Error Amp Block (CH2, CH3) [Error Amp2, Error Amp3]	Threshold voltage	V _{TH}	9, 12	FB2 = FB3 = 2.25 V	1.218	1.230	1.242	V
	Input bias current	I _B	9, 12	- INE2 = - INE3 = 0 V	- 250	- 63	—	nA
	Voltage gain	A _V	8, 13	DC	60	100	—	dB
	Frequency band width	B _W	8, 13	A _V = 0 dB	—	1.5*	—	MHz
	Output voltage	V _{OH}	8, 13	—	3.2	3.4	—	V
		V _{OL}	8, 13	—	—	40	200	mV
	Output source current	I _{SOURCE}	8, 13	FB2 = FB3 = 2.25 V	—	- 2	- 1	mA
	Output sink current	I _{SINK}	8, 13	FB2 = FB3 = 2.25 V	150	250	—	μA

* : Standard design value

(Continued)

(Continued)

(VCC = VCCO = 12 V, Ta = + 25 °C)

Parameter		Symbol	Pin No.	Conditions	Value			Unit
					Min	Typ	Max	
PWM Comparator Block [PWM Comp.]	Threshold voltage	V _{T0}	17 to 19	Duty cycle = 0 %	1.9	2.0	—	V
		V _{T100}	17 to 19	Duty cycle = 100 %	—	2.5	2.6	V
Bias Voltage Block [VH]	Output voltage	V _H	16	—	V _{CCO} – 5.5	V _{CCO} – 5.0	V _{CCO} – 4.5	V
Output Block [Drive]	Output source current	I _{SOURCE}	17 to 19	Duty ≤ 5 % OUT1 = OUT2 = OUT3 = 7 V	—	– 150*	—	mA
	Output sink current	I _{SINK}	17 to 19	Duty ≤ 5 % OUT1 = OUT2 = OUT3 = 12 V	—	150*	—	mA
	Output ON resistor	R _{OH}	17 to 19	OUT1 = OUT2 = OUT3 = – 15 mA	—	13	19.5	Ω
		R _{OL}	17 to 19	OUT1 = OUT2 = OUT3 = 15 mA	—	10	15	Ω
General	Power supply current	I _{CC}	4	—	—	6	9	mA

* : Standard design value

■ TYPICAL CHARACTERISTICS

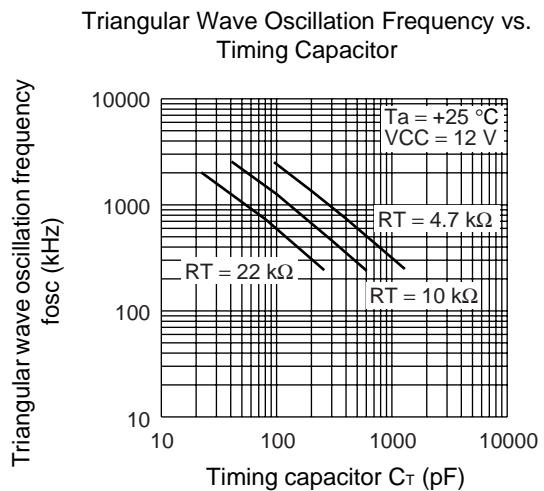
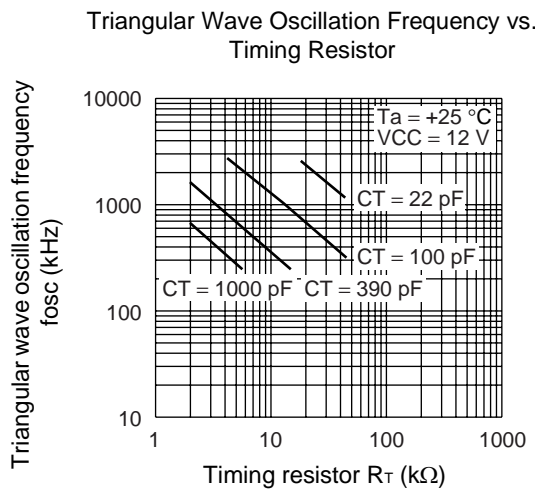
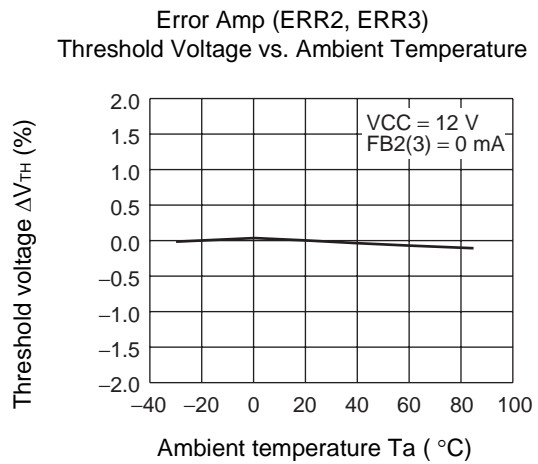
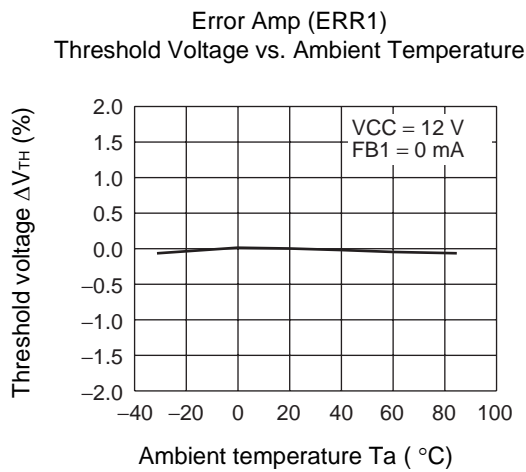
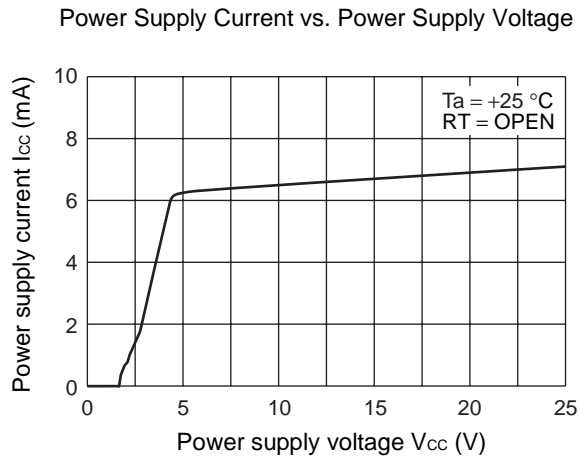

(Continued)

Triangular Wave Upper/Lower Limit Voltage vs. Triangular Wave Oscillation Frequency

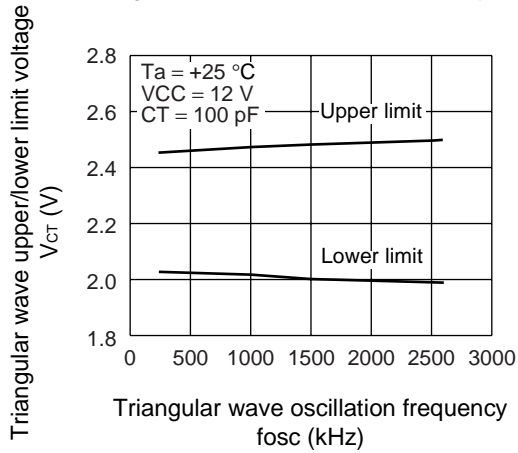

Triangular Wave Upper/Lower Limit Voltage vs. Ambient Temperature

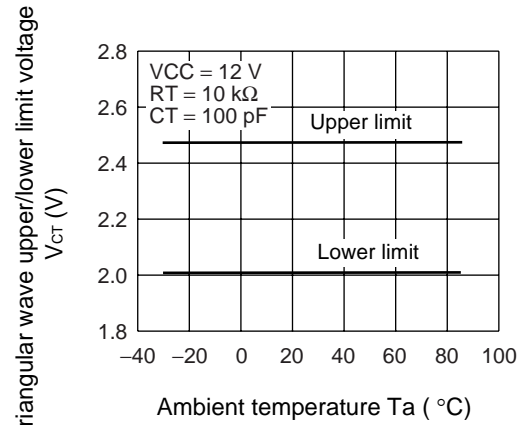

Triangular Wave Oscillation Frequency vs. Ambient Temperature

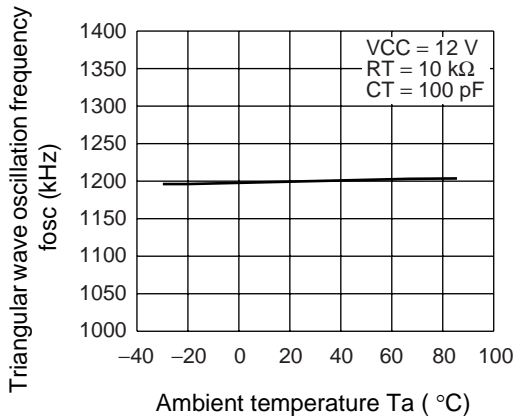

Triangular Wave Oscillation Frequency vs. Power Supply Voltage

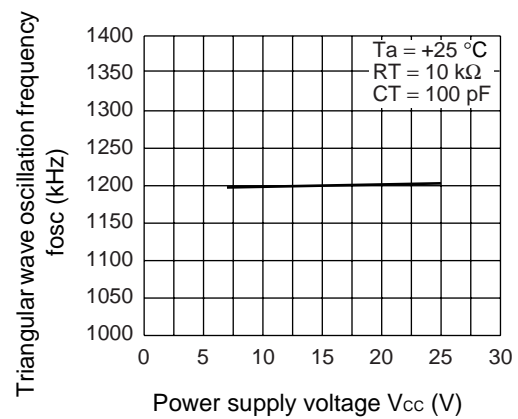

(Continued)

MB39A112

(Continued)

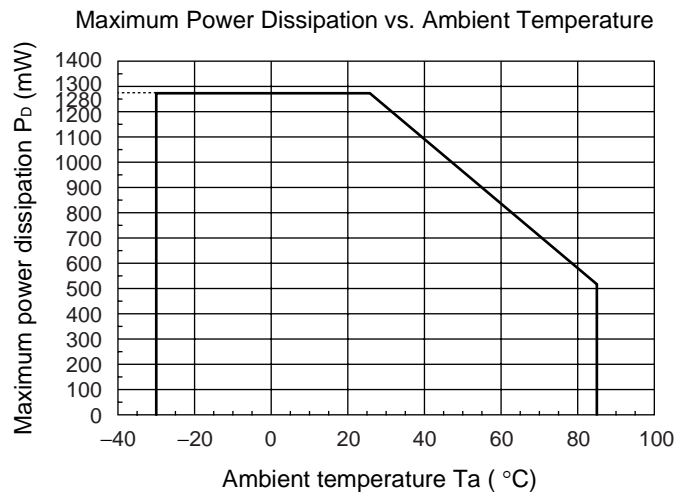
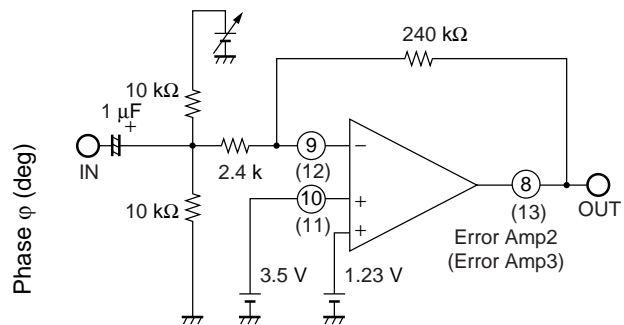
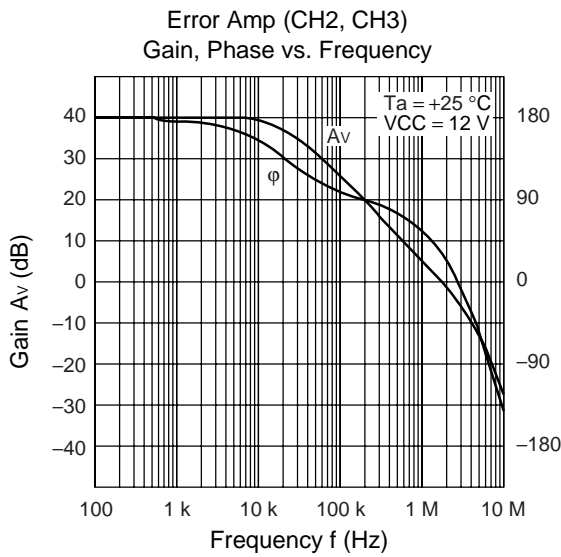
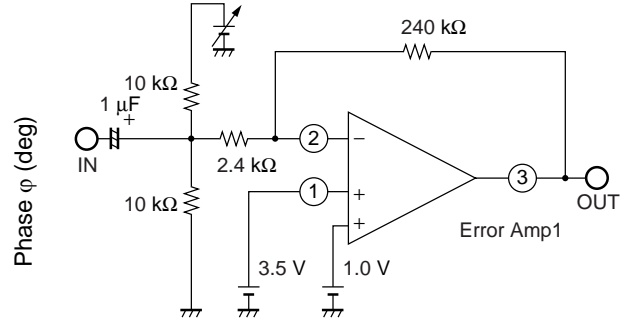
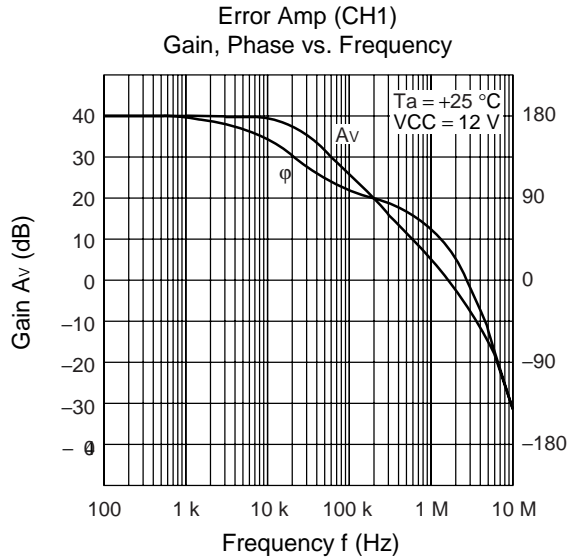

■ FUNCTION

1. DC/DC Converter Function

(1) Triangular Wave Oscillator Block (OSC)

The triangular wave oscillator incorporates a timing capacitor and a timing resistor connected respectively to the CT terminl (pin 6) and RT terminl (pin 5) to generate triangular oscillation waveform amplitude of 2.0 V to 2.5 V. The triangular waveforms are input to the PWM comparator in the IC.

(2) Error Amplifier Block (Error Amp1, Error Amp2, Error Amp3)

The error amplifier detects the DC/DC converter output voltage and outputs PWM control signals. In addition, an arbitrary loop gain can be set by connecting a feedback resistor and capacitor from the output terminal to inverted input terminal of the error amplifier, enabling stable phase compensation to the system.

Also, it is possible to prevent rush current at power supply start-up by connecting a soft-start capacitor with the CS1 terminl (pin 1) , CS2 terminl (pin10) and CS3 terminl (pin 11) which are the non-inverted input terminal for Error Amp. The use of error Amp for soft-start detection makes it possible for a system to operate on a fixed soft-start time that is independent of the output load on the DC/DC converter.

(3) PWM Comparator Block (PWM Comp.)

The PWM comparator is a voltage-to-pulse width modulator that controls the output duty depending on the input/output voltage.

The comparator keeps output transistor on while the error amplifier output voltage remain higher than the triangular wave voltage.

(4) Output Block

The output blokb is in the totem pole configulation, capable of driving an external P-channel MOS FET.

(5) Bias Voltage Block (VH)

This bias voltage circuit outputs $V_{CC} - 5\text{ V}$ (Typ) as minimum potential of the output circuit.

2. Protective Function

(1) Timer Latch Short-circuit Protection Circuit (SCP)

Each channel has a short-circuit detection comparator (SCP Comp.) which constantly compares the error Amp. output level to the reference voltage.

While DC/DC converter load conditions are stable on all channels, the short-circuit detection comparator output remains at "L", and the CSCP terminal is held at "L" level.

If the load condition on a channel changes rapidly due to a short-circuit of the load, causing the output voltage to drop, the output of the short-circuit detection comparator on that channel goes to "H" level. This causes the external short-circuit protection capacitor C_{SCP} connected to the CSCP terminal (pin 14) to be charged.

When the capacitor C_{SCP} is charged to the threshold voltage ($V_{TH} \approx 0.72\text{ V}$) , the latch is set and the external FET is turned off (dead time is set to 100 %) . At this point, the latch input is closed and the CSCP terminal is held at "L" level.

The latch applied by the timer-latch short-circuit protection circuit can be reset by recycling the power supply (VCC) (See "■ SETTING TIME CONSTANT FOR TIMER-LATCH SHORT-CIRCUIT PROTECTION CIRCUIT").

(2) Undervoltage Lockout Protection Circuit Block (UVLO)

The transient state or a momentary decrease in supply voltage, which occurs when the power supply is turned on, may cause the IC to malfunction, resulting in breakdown or degradation of the system. To prevent such malfunctions, under voltage lockout protection circuit detects a decrease in internal reference voltage with respect to the power supply voltage, turns off the output transistor, and sets the dead time to 100% while holding the CSCP terminal (pin 14) at the “L” level.

The circuit restores the output transistor to normal when the supply voltage reaches the threshold voltage of the undervoltage lockout protection circuit.

(3) Protection Circuit Operating Function Table

This table refers to output condition when each protection circuit is operating.

Operating circuit	CH1	CH2	CH3
	OUT1	OUT2	OUT3
Short-circuit protection circuit	H	H	H
Under-voltage lockout circuit	H	H	H

The latch can be reset as follows after the short-circuit protection circuit is actuated.

Recycling VCC resets the latch whenever the short-circuit protection circuit has been actuated.

■ SETTING THE OUTPUT VOLTAGE

• CH1

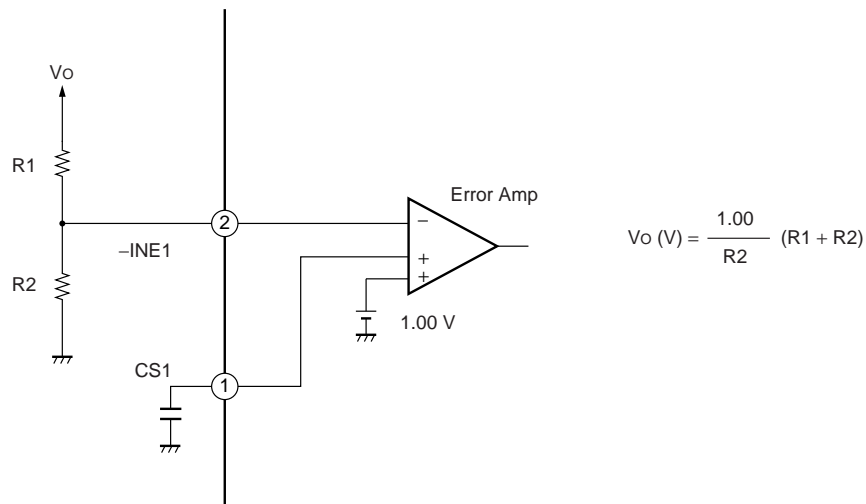

• CH2, CH3

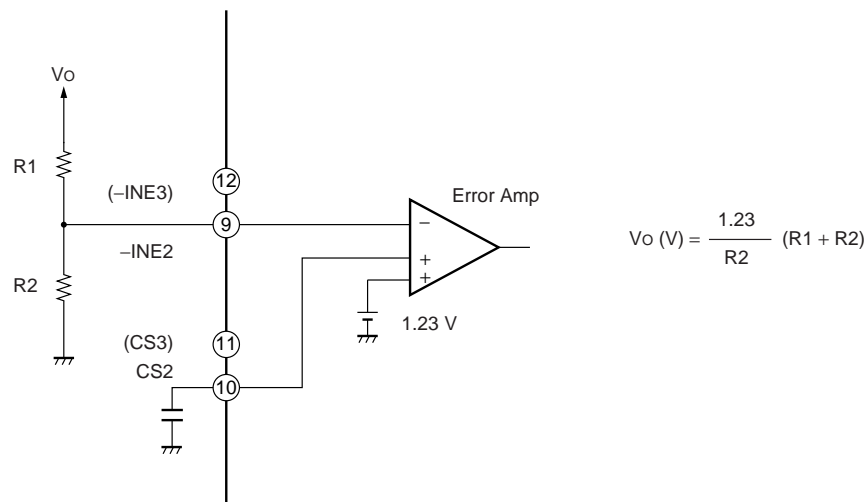

■ SETTING THE TRIANGULAR OSCILLATION FREQUENCY

The triangular oscillation frequency is determined by the timing capacitor (C_T) connected to the C_T terminal (pin 6) and the timing resistor (R_T) connected to the R_T terminal (pin 5).

Triangular oscillation frequency : fosc

$$f_{osc} (\text{kHz}) \cong \frac{1200000}{C_T (\text{pF}) \cdot R_T (\text{k}\Omega)}$$

■ SETTING THE SOFT-START AND DISCHARGE TIMES

To prevent rush currents when the IC is turned on, you can set a soft-start by connecting soft-start capacitors (C_{S1} , C_{S2} and C_{S3}) to the CS1 terminal (pin 1) for channel 1, CS2 terminal (pin 10) for channel 2 and CS3 terminal (pin 11) for channel 3 respectively.

Setting each control terminal (\overline{CTLX}) from "H" to "L" starts charging the external soft-start capacitors (C_{S1} , C_{S2} and C_{S3}) connected to the CS1, CS2 and CS3 terminal at about $10\ \mu\text{A}$. The DC/DC converter output voltage rises in proportion to the CS terminal voltage. Also, soft-start time is obtained by the following formulas.

Soft-start time : t_s (time to output 100%)

CH1 : $t_{s1}[\text{s}] \doteq 0.100 \times C_{S1}[\mu\text{F}]$

CH2 : $t_{s2}[\text{s}] \doteq 0.123 \times C_{S2}[\mu\text{F}]$

CH3 : $t_{s3}[\text{s}] \doteq 0.123 \times C_{S3}[\mu\text{F}]$

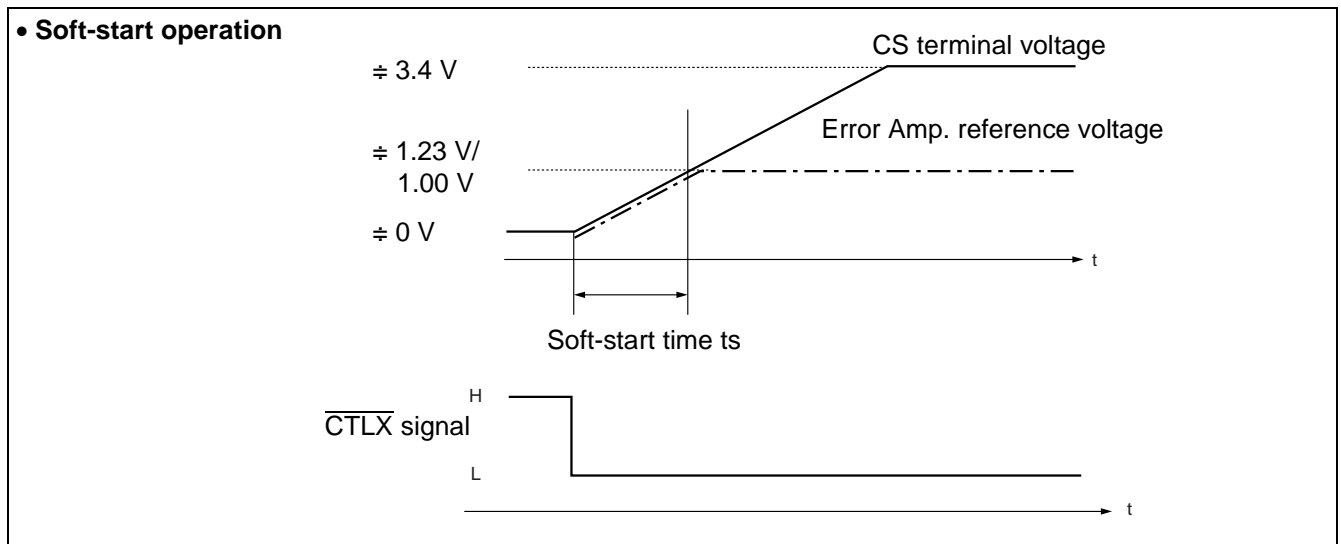
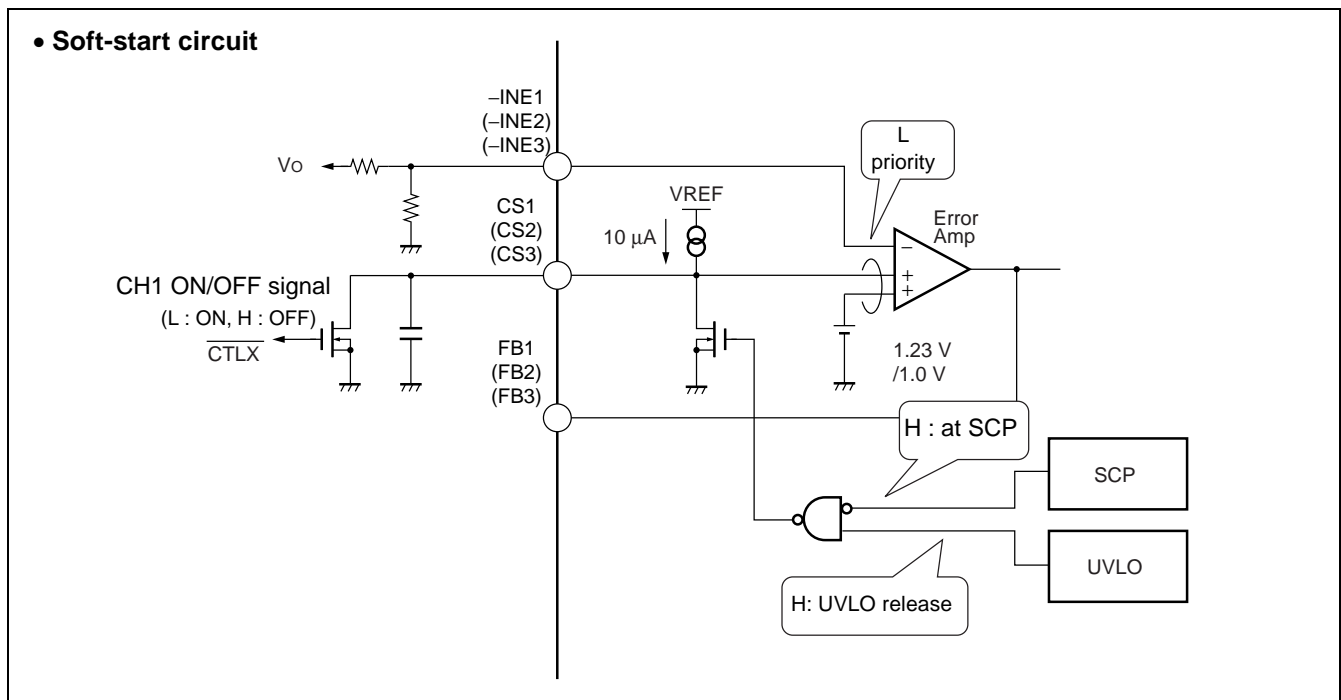

■ TREATMENT WITHOUT USING CS TERMINAL

When not using the soft-start function, open the CS1 terminal (pin 1) , CS2 terminal (pin 10) and CS3 terminal (pin 11) .

- Without setting soft-start tme

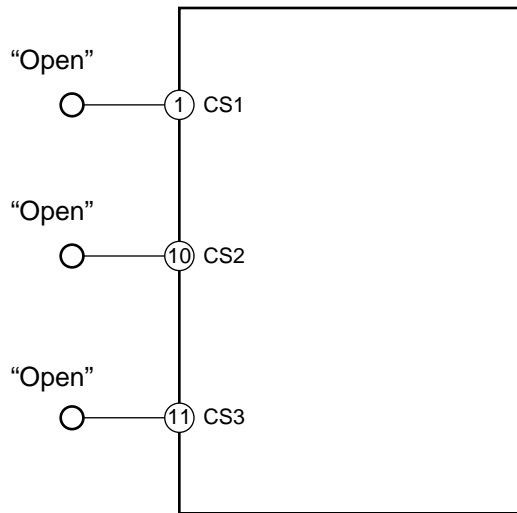

■ SETTING TIME CONSTANT FOR TIMER-LATCH SHORT-CIRCUIT PROTECTION CIRCUIT

Each channel uses the short-circuit detection comparator (SCP Comp.) to always compare the error amplifier's output level to the reference voltage.

While DC/DC converter load conditions are stable on all channels, the short-circuit detection comparator output remains at "L" level, and the CSCP terminal (pin 14) is held at "L" level.

If the load condition on a channel changes rapidly due to a short-circuit of the load, causing the output voltage to drop, the output of the short-circuit detection comparator goes to "H" level. This causes the external short-circuit protection capacitor C_{SCP} connected to the CSCP terminal to be charged at 1 μA .

Short-circuit detection time : t_{cscp}

$$t_{cscp}[s] \approx 0.72 \times C_{SCP} [\mu\text{F}]$$

When the capacitor C_{SCP} is charged to the threshold voltage ($V_{TH} \approx 0.72 \text{ V}$), the latch is set and the external FET is turned off (dead time is set to 100 %). At this time, the latch input is closed and the CSCP terminal (pin 14) is held at "L" level.

If any of CH1 to CH3 detects a short circuit, all the channels are stopped.

• Timer-latch short-circuit protection circuit

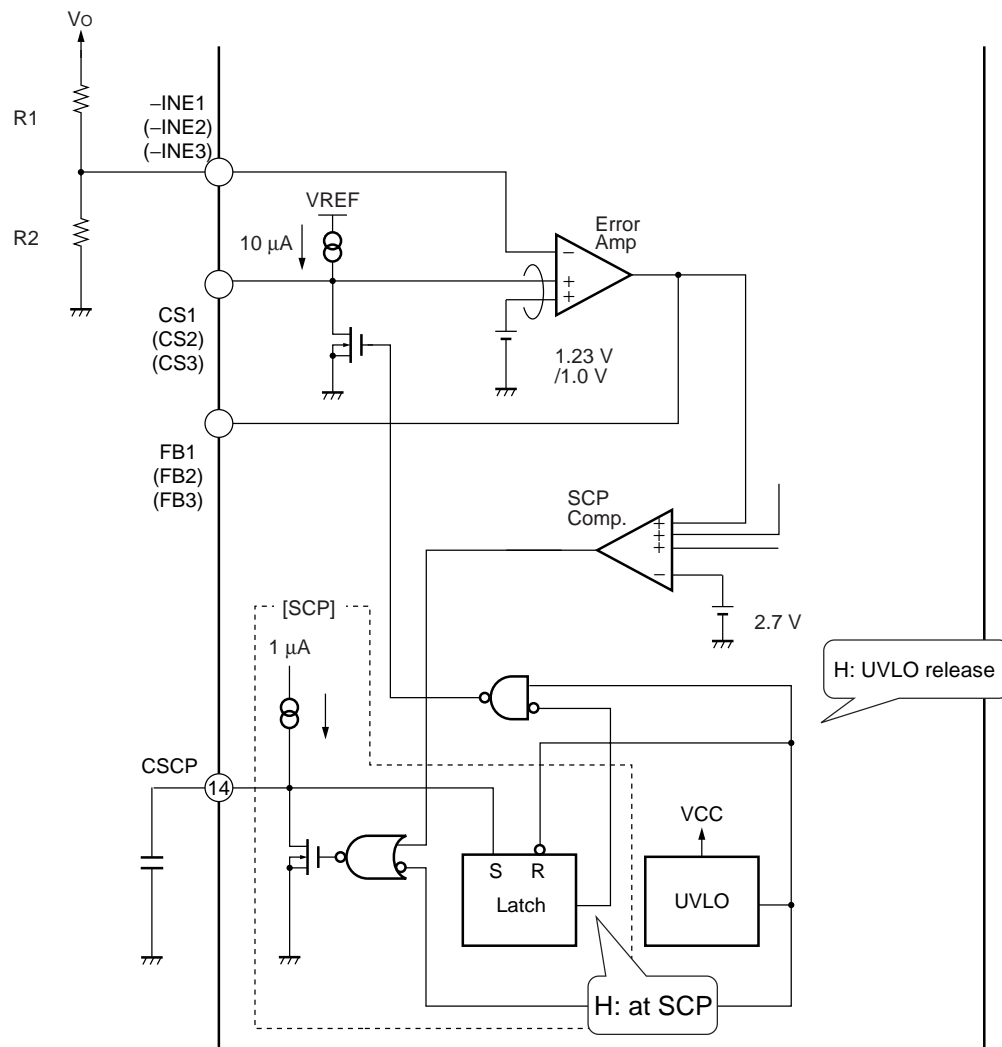

■ TREATMENT WITHOUT USING CSCP TERMINAL

When not using the timer-latch short-circuit protection circuit, connect the CSCP terminal (pin 14) to GND with the shortest distance.

- Treatment without using CSCP terminal

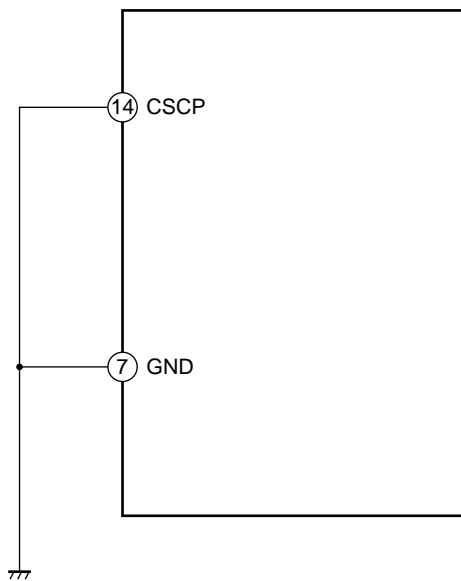

MB39A112

I/O EQUIVALENT CIRCUIT

<<Short-circuit detection block>>

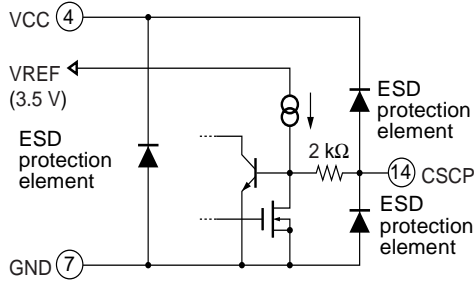

<<Triangular wave oscillator block (RT)>>

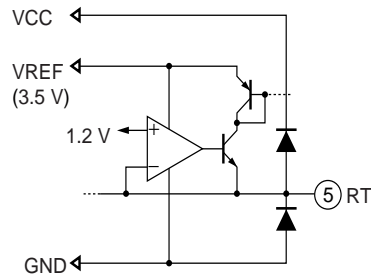

<<Triangular wave oscillator block (CT)>>

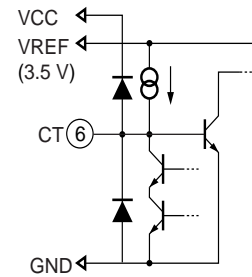

<<Soft-start block>>

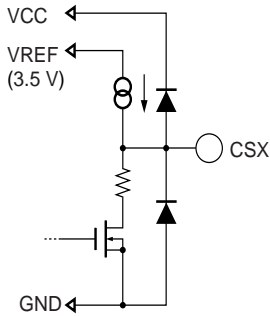

<<Error amplifier block (CH1)>>

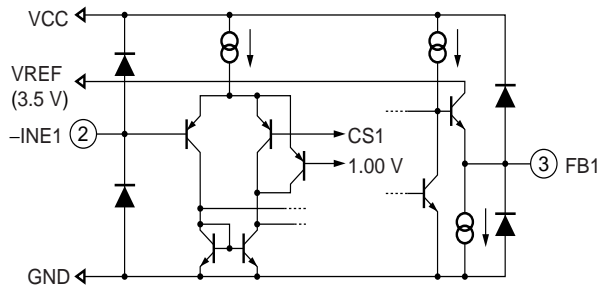

<<Error amplifier block (CH2, CH3)>>

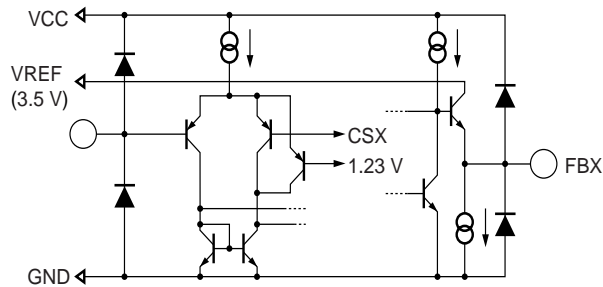

<<PWM comparator block>>

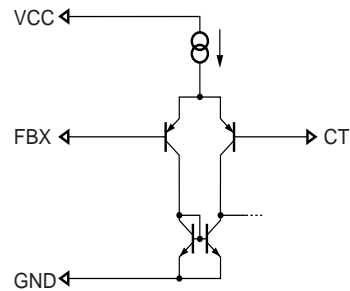

<<Bias voltage block>>

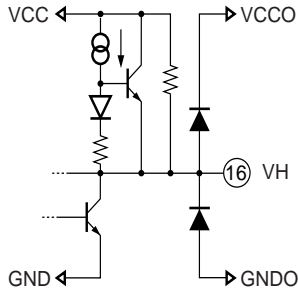

<<Output block>>

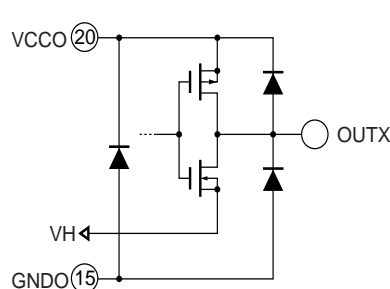

X : Each channel No.

APPLICATION EXAMPLE

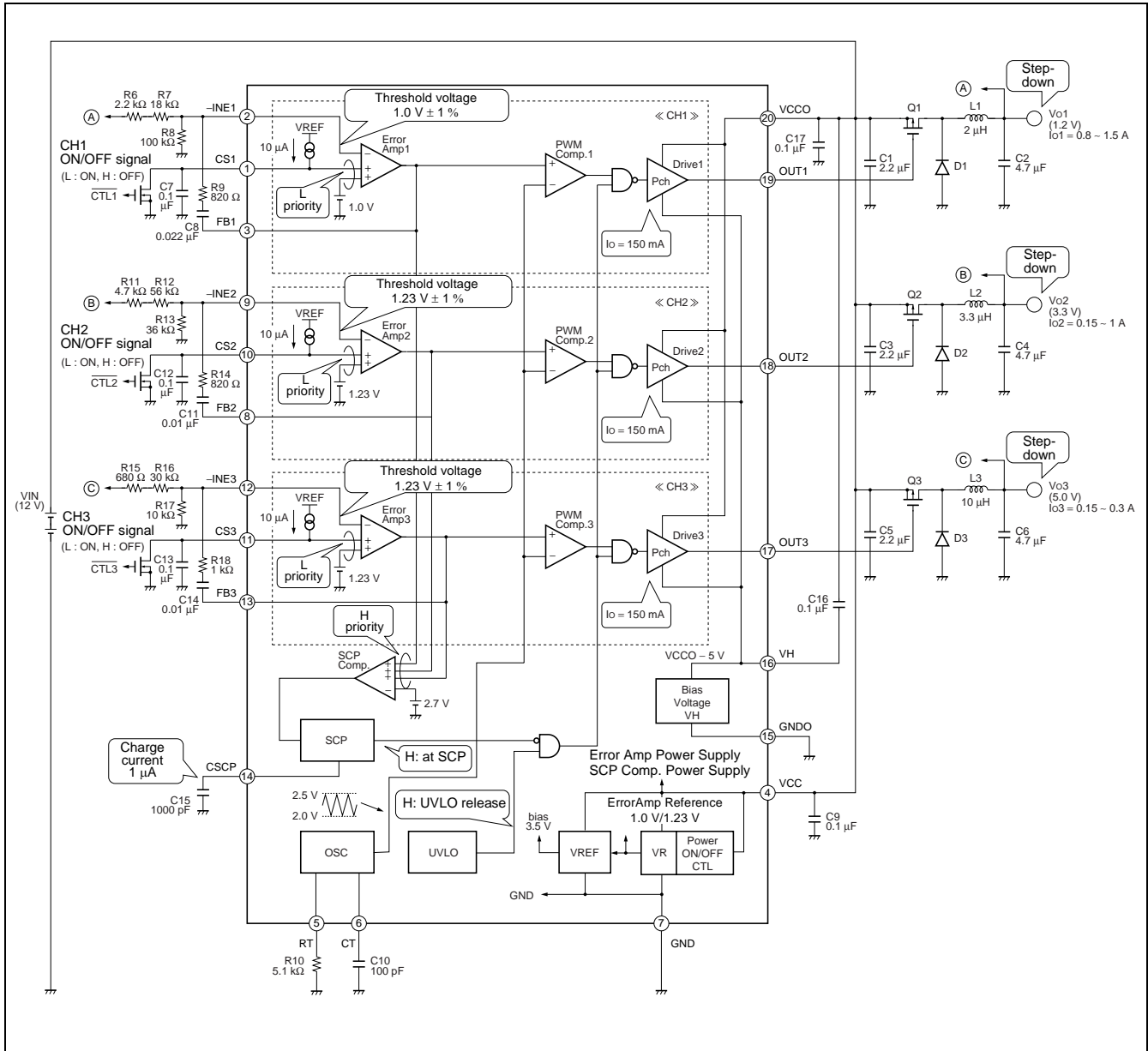

MB39A112

■ PARTS LIST

COMPONENT	ITEM	SPECIFICATION		VENDOR	PARTS No.
Q1, Q2, Q3	Pch FET Pch FET	VDS = - 30 V, ID = - 2.0 A VDS = - 30 V, ID = - 1.0 A		SANYO SANYO	MCH3312 MCH3308
D1, D2 D3	Diode Diode	VF = 0.55 V (Max) , at IF = 2 A VF = 0.4 V (Max) , at IF = 0.5 A		SANYO SANYO	SBE001 SBE005
L1 L2 L3	Inductor Inductor Inductor	2 μ H 3.3 μ H 10 μ H	3 A, 16 m Ω 2.57 A, 21.4 m Ω 1.49 A, 41.2 m Ω	TOKO TOKO TOKO	A916CY-2R0M A916CY-3R3M A916CY-100M
C1, C3, C5 C2, C4, C6 C7, C9, C12 C8 C10 C11, C14 C13, C16, C17 C15	Ceramics Condenser Ceramics Condenser Ceramics Condenser Ceramics Condenser Ceramics Condenser Ceramics Condenser Ceramics Condenser Ceramics Condenser Ceramics Condenser	2.2 μ F 4.7 μ F 0.1 μ F 0.022 μ F 100 pF 0.01 μ F 0.1 μ F 1000 pF	25 V 10 V 50 V 50 V 50 V 50 V 50 V 50 V	TDK TDK TDK TDK TDK TDK TDK TDK	C3216JB1E225K C3216JB1A475M C1608JB1H104K C1608JB1H223K C1608CH1H101J C1608JB1H103K C1608JB1H104K C1608JB1H102K
R6 R7 R8 R9 R10 R11 R12 R13 R14 R15 R16 R17 R18	Resistor Resistor Resistor Resistor Resistor Resistor Resistor Resistor Resistor Resistor Resistor Resistor Resistor	2.2 k Ω 18 k Ω 100 k Ω 820 Ω 5.1 k Ω 4.7 k Ω 56 k Ω 36 k Ω 820 Ω 680 Ω 30 k Ω 10 k Ω 1 k Ω	0.5 % 0.5 % 0.5 % 0.5 % 0.5 % 0.5 % 0.5 % 0.5 % 0.5 % 0.5 % 0.5 % 0.5 % 0.5 %	ssm ssm ssm ssm ssm ssm ssm ssm ssm ssm ssm ssm ssm	RR0816P-222-D RR0816P-183-D RR0816P-104-D RR0816P-821-D RR0816P-512-D RR0816P-472-D RR0816P-563-D RR0816P-363-D RR0816P-821-D RR0816P-681-D RR0816P-303-D RR0816P-103-D RR0816P-102-D

Note : SANYO : SANYO Electric Co., Ltd.
TOKO : TOKO Inc.
TDK : TDK Corporation
ssm : SUSUMU Co., Ltd.

■ SELECTION OF COMPONENTS

- Pch MOS FET

The Pch MOS FET for switching use should be rated for at least 20 % or more than the maximum input voltage. To minimize continuity loss, use a FET with low $R_{DS(ON)}$ between the drain and source. For high input voltage and high frequency operation, on-cycle switching loss will be higher so that power dissipation must be considered. In this application, the SANYO MCH3312 and MCH3308 are used. Continuity loss, on/off-cycle switching loss and total loss are determined by the following formulas. The selection must ensure that peak drain current does not exceed rated values.

Continuity loss : P_C

$$P_C = I_D^2 \times R_{DS(ON)} \times \text{Duty}$$

On-cycle switching loss : $P_{S(ON)}$

$$P_{S(ON)} = \frac{V_{D(Max)} \times I_D \times t_r \times f_{osc}}{6}$$

Off-cycle switching loss : $P_{S(OFF)}$

$$P_{S(OFF)} = \frac{V_{D(Max)} \times I_{D(Max)} \times t_f \times f_{osc}}{6}$$

Total loss : P_T

$$P_T = P_C + P_{S(ON)} + P_{S(OFF)}$$

Example : Using the MCH3312

- CH1

Input voltage $V_{IN} = 12 \text{ V}$, output voltage $V_O = 1.2 \text{ V}$, drain current $I_D = 1.5 \text{ A}$, oscillation frequency $f_{osc} = 2350 \text{ kHz}$, $L = 2 \mu\text{H}$, drain-source on resistance $R_{DS(ON)} \cong 180 \text{ m}\Omega$, $t_r \cong 2.9 \text{ ns}$, $t_f \cong 8.7 \text{ ns}$.

Drain current (Max) : $I_{D(Max)}$

$$\begin{aligned} I_{D(Max)} &= I_o + \frac{V_{IN} - V_o}{2L} t_{ON} \\ &= 1.5 + \frac{12 - 1.2}{2 \times 2.0 \times 10^{-6}} \times \frac{1}{2350 \times 10^3} \times 0.1 \\ &\cong \underline{1.61 \text{ A}} \end{aligned}$$

Drain current (Min) : $I_{D(Min)}$

$$\begin{aligned} I_{D(Min)} &= I_o - \frac{V_{IN} - V_o}{2L} t_{ON} \\ &= 1.5 - \frac{12 - 1.2}{2 \times 2.0 \times 10^{-6}} \times \frac{1}{2350 \times 10^3} \times 0.1 \\ &\cong \underline{1.39 \text{ A}} \end{aligned}$$

MB39A112

$$\begin{aligned} P_C &= I_D^2 \times R_{DS(ON)} \times \text{Duty} \\ &= 1.5^2 \times 0.18 \times 0.1 \\ &\doteq \underline{0.04 \text{ W}} \end{aligned}$$

$$\begin{aligned} P_{S(ON)} &= \frac{V_D \times I_D \times t_r \times f_{osc}}{6} \\ &= \frac{12 \times 1.5 \times 2.9 \times 10^{-9} \times 2350 \times 10^3}{6} \\ &\doteq \underline{0.02 \text{ W}} \end{aligned}$$

$$\begin{aligned} P_{S(OFF)} &= \frac{V_D \times I_{D(Max)} \times t_f \times f_{osc}}{6} \\ &= \frac{12 \times 1.61 \times 8.7 \times 10^{-9} \times 2350 \times 10^3}{6} \\ &\doteq \underline{0.066 \text{ W}} \end{aligned}$$

$$\begin{aligned} P_T &= P_C + P_{S(ON)} + P_{S(OFF)} \\ &\doteq 0.04 + 0.02 + 0.066 \\ &\doteq \underline{0.126 \text{ W}} \end{aligned}$$

The above power dissipation figures for the MCH3312 are satisfied with ample margin at 1.0 W ($T_a = +25^\circ\text{C}$).

- CH2

Input voltage $V_{IN} = 12 \text{ V}$, output voltage $V_O = 3.3 \text{ V}$, drain current $I_D = 1.0 \text{ A}$, oscillation frequency $f_{osc} = 2350 \text{ kHz}$, $L = 3.3 \mu\text{H}$, drain-source on resistance $R_{DS(ON)} \doteq 180 \text{ m}\Omega$, $t_r \doteq 2.9 \text{ ns}$, $t_f \doteq 8.7 \text{ ns}$.

Drain current (Max) : $I_{D(Max)}$

$$\begin{aligned} I_{D(Max)} &= I_o + \frac{V_{IN} - V_o}{2L} t_{ON} \\ &= 1 + \frac{12 - 3.3}{2 \times 3.3 \times 10^{-6}} \times \frac{1}{2350 \times 10^3} \times 0.275 \\ &\doteq \underline{1.15 \text{ A}} \end{aligned}$$

Drain current (Min) : $I_{D(Min)}$

$$\begin{aligned} I_{D(Min)} &= I_o - \frac{V_{IN} - V_o}{2L} t_{ON} \\ &= 1 - \frac{12 - 3.3}{2 \times 3.3 \times 10^{-6}} \times \frac{1}{2350 \times 10^3} \times 0.275 \\ &\doteq \underline{0.85 \text{ A}} \end{aligned}$$

$$\begin{aligned} P_C &= I_D^2 \times R_{DS(ON)} \times \text{Duty} \\ &= 1^2 \times 0.18 \times 0.275 \\ &\doteq \underline{0.0495 \text{ W}} \end{aligned}$$

$$\begin{aligned}
 P_{S(ON)} &= \frac{V_D \times I_D \times t_r \times f_{osc}}{6} \\
 &= \frac{12 \times 1 \times 2.9 \times 10^{-9} \times 2350 \times 10^3}{6} \\
 &\approx \underline{0.0136 \text{ W}}
 \end{aligned}$$

$$\begin{aligned}
 P_{S(OFF)} &= \frac{V_D \times I_{D(Max)} \times t_f \times f_{osc}}{6} \\
 &= \frac{12 \times 1.15 \times 8.7 \times 10^{-9} \times 2350 \times 10^3}{6} \\
 &\approx \underline{0.047 \text{ W}}
 \end{aligned}$$

$$\begin{aligned}
 P_T &= P_C + P_{S(ON)} + P_{S(OFF)} \\
 &\approx 0.0495 + 0.0136 + 0.047 \\
 &\approx \underline{0.11 \text{ W}}
 \end{aligned}$$

The above power dissipation figures for the MCH3312 are satisfied with ample margin at 1.0 W ($T_a = +25^\circ\text{C}$).

Example : Using the MCH3308

- CH3

Input voltage $V_{IN} = 12 \text{ V}$, output voltage $V_o = 5.0 \text{ V}$, drain current $I_D = 0.3 \text{ A}$, oscillation frequency $f_{osc} = 2350 \text{ kHz}$, $L = 10 \mu\text{H}$, drain-source on resistance $R_{DS(ON)} \approx 600 \text{ m}\Omega$, $t_r \approx 4 \text{ ns}$, $t_f \approx 4 \text{ ns}$.

Drain current (Max) : $I_{D(Max)}$

$$\begin{aligned}
 I_{D(Max)} &= I_o + \frac{V_{IN} - V_o}{2L} t_{ON} \\
 &= 0.3 + \frac{12 - 5}{2 \times 10 \times 10^{-6}} \times \frac{1}{2350 \times 10^3} \times 0.417 \\
 &\approx \underline{0.36 \text{ (A)}}
 \end{aligned}$$

Drain current (Min) : $I_{D(Min)}$

$$\begin{aligned}
 I_{D(Min)} &= I_o - \frac{V_{IN} - V_o}{2L} t_{ON} \\
 &= 0.3 - \frac{12 - 5}{2 \times 10 \times 10^{-6}} \times \frac{1}{2350 \times 10^3} \times 0.417 \\
 &\approx \underline{0.24 \text{ (A)}}
 \end{aligned}$$

$$\begin{aligned}
 P_C &= I_D^2 \times R_{DS(ON)} \times \text{Duty} \\
 &= 0.3^2 \times 0.6 \times 0.417 \\
 &\approx \underline{0.023 \text{ W}}
 \end{aligned}$$

MB39A112

$$\begin{aligned} P_{S(ON)} &= \frac{V_D \times I_D \times tr \times f_{osc}}{6} \\ &= \frac{12 \times 0.3 \times 4 \times 10^{-9} \times 2350 \times 10^3}{6} \\ &\doteq \underline{0.0056 \text{ W}} \end{aligned}$$

$$\begin{aligned} P_{S(OFF)} &= \frac{V_D \times I_{D(Max)} \times tf \times f_{osc}}{6} \\ &= \frac{12 \times 0.36 \times 4 \times 10^{-9} \times 2350 \times 10^3}{6} \\ &\doteq \underline{0.0068 \text{ W}} \end{aligned}$$

$$\begin{aligned} P_T &= P_C + P_{S(ON)} + P_{S(OFF)} \\ &\doteq 0.023 + 0.0056 + 0.0068 \\ &\doteq \underline{0.0354 \text{ W}} \end{aligned}$$

The above power dissipation figures for the MCH3308 are satisfied with ample margin at 0.8 W ($T_a = +25^\circ\text{C}$).

• Inductors

In selecting inductors, it is of course essential not to apply more current than the rated capacity of the inductor, but also to note that the lower limit for ripple current is a critical point that if reached will cause discontinuous operation and a considerable drop in efficiency. This can be prevented by choosing a higher inductance value, which will enable continuous operation under light loads. Note that if the inductance value is too high, however, direct current resistance (DCR) is increased and this will also reduce efficiency. The inductance must be set at the point where efficiency is greatest.

Note also that the DC superimposition characteristics become worse as the load current value approaches the rated current value of the inductor, so that the inductance value is reduced and ripple current increases, causing loss of efficiency. The selection of rated current value and inductance value will vary depending on where the point of peak efficiency lies with respect to load current.

Inductance values are determined by the following formulas.

The L value for all load current conditions is set so that the peak to peak value of the ripple current is 1/2 the load current or less.

Inductance value : L

$$L \geq \frac{2(V_{IN} - V_O)}{I_O} t_{ON}$$

Example

• CH1

$$\begin{aligned} L &\geq \frac{2(V_{IN} - V_{O1})}{I_O} t_{ON} \\ &\geq \frac{2 \times (12 - 1.2)}{1.5} \times \frac{1}{2350 \times 10^3} \times 0.1 \\ &\geq \underline{0.61 \mu\text{H}} \end{aligned}$$

- CH2

$$L \geq \frac{2(V_{IN} - V_{O2})}{I_o} t_{ON}$$

$$\geq \frac{2 \times (12 - 3.3)}{1} \times \frac{1}{2350 \times 10^3} \times 0.275$$

$$\geq \underline{2.04 \mu H}$$

- CH3

$$L \geq \frac{2(V_{IN} - V_{O3})}{I_o} t_{ON}$$

$$\geq \frac{2 \times (12 - 5)}{0.3} \times \frac{1}{2350 \times 10^3} \times 0.417$$

$$\geq \underline{8.28 \mu H}$$

Inductance values derived from the above formulas are values that provide sufficient margin for continuous operation at maximum load current, but at which continuous operation is not possible at light loads. It is therefore necessary to determine the load level at which continuous operation becomes possible. In this application, the TOKO A916CY-2R0M, A916CY-3R3M and A916CY-100M are used. At 2 μH, 3.3 μH and 10 μH, the load current value under continuous operating conditions is determined by the following formula.

Load current value under continuous operating conditions : I_o

$$I_o \geq \frac{V_o}{2L} t_{OFF}$$

Example : Using the A916CY-2R0M

2 μH (allowable tolerance ± 20 %), rated current = 3 A

- CH1

$$I_o \geq \frac{V_{O1}}{2L} t_{OFF}$$

$$\geq \frac{1.2}{2 \times 2 \times 10^{-6}} \times \frac{1}{2350 \times 10^3} \times (1 - 0.1)$$

$$\geq \underline{0.11 A}$$

Example : Using the A916CY-3R3M

3.3 μH (allowable tolerance ± 20 %), rated current = 2.57 A

- CH2

$$I_o \geq \frac{V_{O2}}{2L} t_{OFF}$$

$$\geq \frac{3.3}{2 \times 3.3 \times 10^{-6}} \times \frac{1}{2350 \times 10^3} \times (1 - 0.275)$$

$$\geq \underline{0.15 A}$$

MB39A112

Example : Using the A916CY-100M

10.0 μ H (allowable tolerance $\pm 20\%$), rated current = 1.49 A

• CH3

$$\begin{aligned} I_o &\geq \frac{V_o3}{2L} t_{OFF} \\ &\geq \frac{5}{2 \times 10 \times 10^{-6}} \times \frac{1}{2350 \times 10^3} \times (1 - 0.417) \\ &\geq \underline{62.0 \text{ mA}} \end{aligned}$$

To determine whether the current through the inductor is within rated values, it is necessary to determine the peak value of the ripple current as well as the peak-to-peak values of the ripple current that affect the output ripple voltage. The peak value and peak-to-peak value of the ripple current can be determined by the following formulas.

Peak value : I_L

$$I_L \geq I_o + \frac{V_{IN} - V_o}{2L} t_{ON}$$

Peak-to-peak value : ΔI_L

$$\Delta I_L = \frac{V_{IN} - V_o}{L} t_{ON}$$

Example : Using the A916CY-2R0M

2.0 μ H (allowable tolerance $\pm 20\%$), rated current = 3.0 A

• CH1

Peak value

$$\begin{aligned} I_L &\geq I_o + \frac{V_{IN} - V_o1}{2L} t_{ON} \\ &\geq 1.5 + \frac{12 - 1.2}{2 \times 2.0 \times 10^{-6}} \times \frac{1}{2350 \times 10^3} \times 0.1 \\ &\geq \underline{1.61 \text{ A}} \end{aligned}$$

Peak-to-peak value

$$\begin{aligned} \Delta I_L &= \frac{V_{IN} - V_o1}{L} t_{ON} \\ &= \frac{12 - 1.2}{2.0 \times 10^{-6}} \times \frac{1}{2350 \times 10^3} \times 0.1 \\ &= \underline{0.23 \text{ A}} \end{aligned}$$

Example : Using the A916CY-3R3M

3.3 μ H (allowable tolerance $\pm 20\%$), rated current = 2.57 A

• CH2

Peak value

$$\begin{aligned}
 I_L &\geq I_o + \frac{V_{IN} - V_{o2}}{2L} t_{ON} \\
 &\geq 1.0 + \frac{12 - 3.3}{2 \times 3.3 \times 10^{-6}} \times \frac{1}{2350 \times 10^3} \times 0.275 \\
 &\geq \underline{1.15 \text{ A}}
 \end{aligned}$$

Peak-to-peak value

$$\begin{aligned}
 \Delta I_L &= \frac{V_{IN} - V_{o2}}{L} t_{ON} \\
 &= \frac{12 - 3.3}{3.3 \times 10^{-6}} \times \frac{1}{2350 \times 10^3} \times 0.275 \\
 &\neq \underline{0.309 \text{ A}}
 \end{aligned}$$

Example : Using the A916CY-100M

10.0 μ H (allowable tolerance $\pm 20\%$), rated current = 1.49 A

• CH3

Peak value

$$\begin{aligned}
 I_L &\geq I_o + \frac{V_{IN} - V_{o3}}{2L} t_{ON} \\
 &\geq 0.3 + \frac{12 - 5}{2 \times 10 \times 10^{-6}} \times \frac{1}{2350 \times 10^3} \times 0.417 \\
 &\geq \underline{0.36 \text{ A}}
 \end{aligned}$$

Peak-to-peak value

$$\begin{aligned}
 \Delta I_L &= \frac{V_{IN} - V_{o3}}{L} t_{ON} \\
 &= \frac{12 - 5}{10 \times 10^{-6}} \times \frac{1}{2350 \times 10^3} \times 0.417 \\
 &\neq \underline{0.124 \text{ A}}
 \end{aligned}$$

MB39A112

- Flyback diode

The flyback diode is generally used as a Schottky barrier diode (SBD) when the reverse voltage to the diode is less than 40 V. The SBD has the characteristics of higher speed in terms of faster reverse recovery time, and lower forward voltage, and is ideal for achieving high efficiency. As long as the DC reverse voltage is sufficiently higher than the input voltage, the average current flowing through the diode is within the average output current level, and peak current is within peak surge current limits, there is no problem. In this application the SANYO SBE001, SBS005 are used. The diode average current and diode peak current can be calculated by the following formulas.

Diode mean current : I_{Di}

$$I_{Di} \geq I_o \times \left(1 - \frac{V_o}{V_{IN}} \right)$$

Diode peak current : I_{Dip}

$$I_{Dip} \geq \left(I_o + \frac{V_o}{2L} t_{OFF} \right)$$

Example : Using the SBE001

VR (DC reverse voltage) = 30 V, average output current = 2.0 A, peak surge current = 20 A,

VF (forward voltage) = 0.55 V, at $I_F = 2.0$ A

- CH1

Diode mean current

$$\begin{aligned} I_{Di} &\geq I_o \times \left(1 - \frac{V_{o1}}{V_{IN}} \right) \\ &\geq 1.5 \times (1 - 0.1) \\ &\geq \underline{1.35 A} \end{aligned}$$

Diode peak current

$$\begin{aligned} I_{Dip} &\geq \left(I_o + \frac{V_{o1}}{2L} t_{OFF} \right) \\ &\geq \underline{1.61 A} \end{aligned}$$

- CH2

Diode mean current

$$\begin{aligned} I_{Di} &\geq I_o \times \left(1 - \frac{V_{o2}}{V_{IN}} \right) \\ &\geq 1.0 \times (1 - 0.275) \\ &\geq \underline{0.725 A} \end{aligned}$$

Diode peak current

$$I_{Dip} \geq \left(I_o + \frac{V_{o2}}{2L} t_{OFF} \right)$$
$$\geq \underline{1.15 \text{ A}}$$

Example : Using the SBS005

VR (DC reverse voltage) = 30 V, average output current = 1.0 A, peak surge current = 10 A,

VF (forward voltage) = 0.4 V, at IF = 0.5 A

• CH3

Diode mean current

$$I_{Di} \geq I_o \times \left(1 - \frac{V_{o3}}{V_{IN}} \right)$$
$$\geq 0.3 \times (1 - 0.417)$$
$$\geq \underline{0.175 \text{ A}}$$

Diode peak current

$$I_{Dip} \geq \left(I_o + \frac{V_{o3}}{2L} t_{OFF} \right)$$
$$\geq \underline{0.36 \text{ A}}$$

REFERENCE DATA

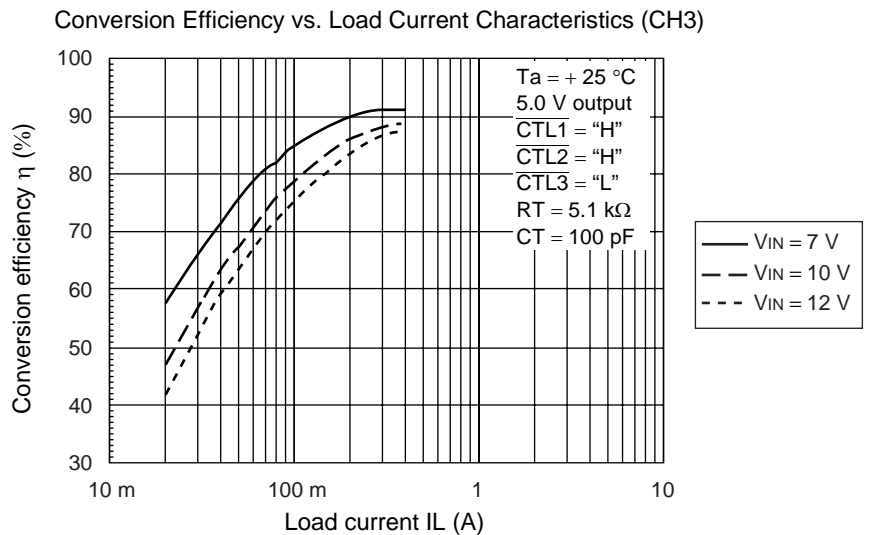
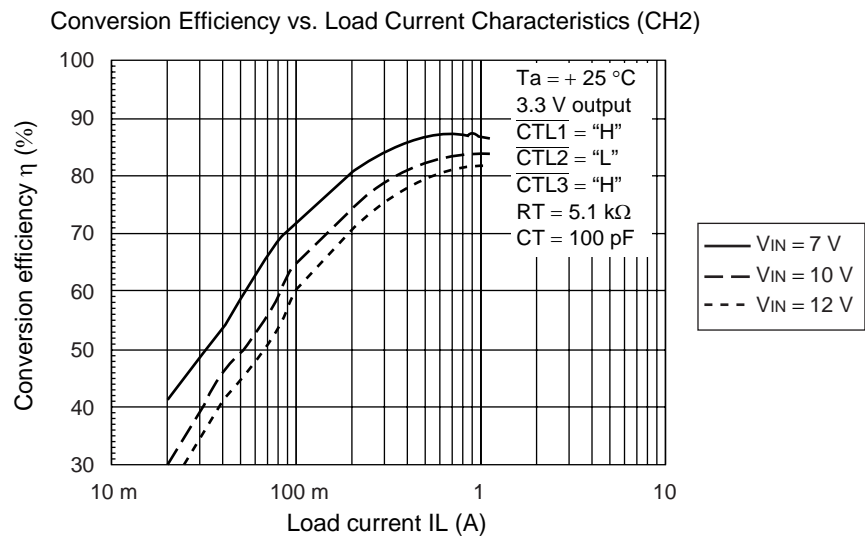
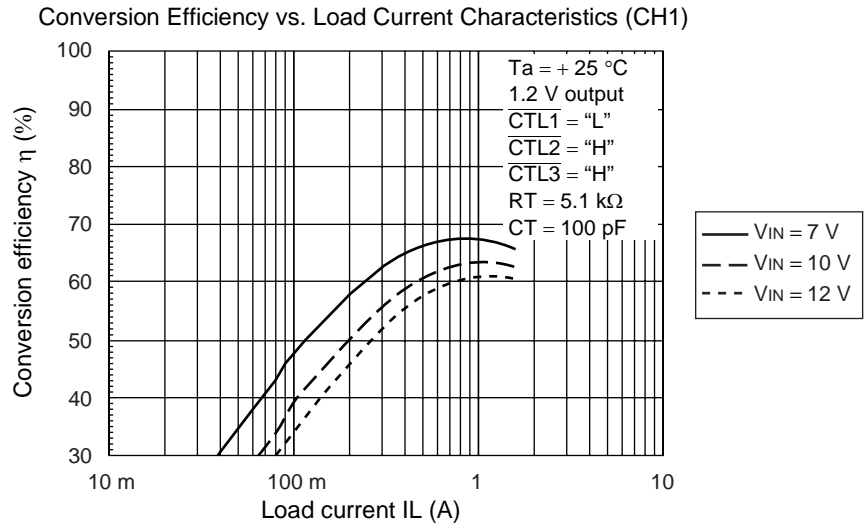

(Continued)

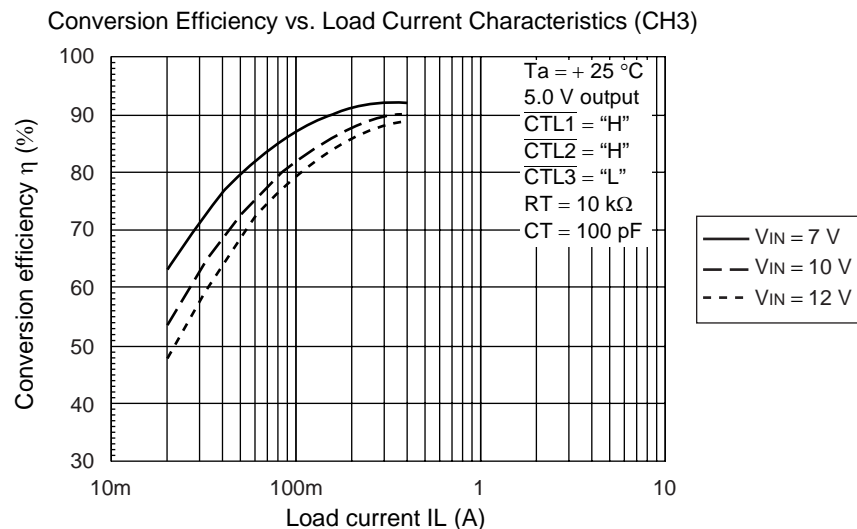
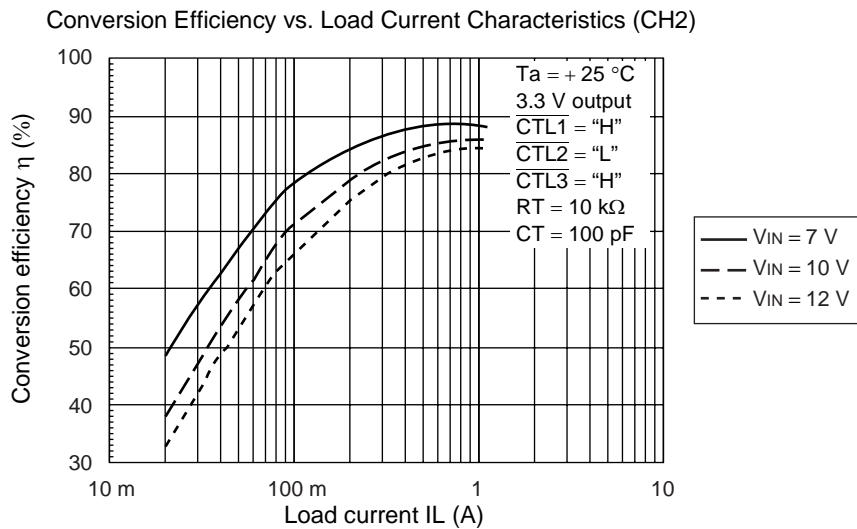
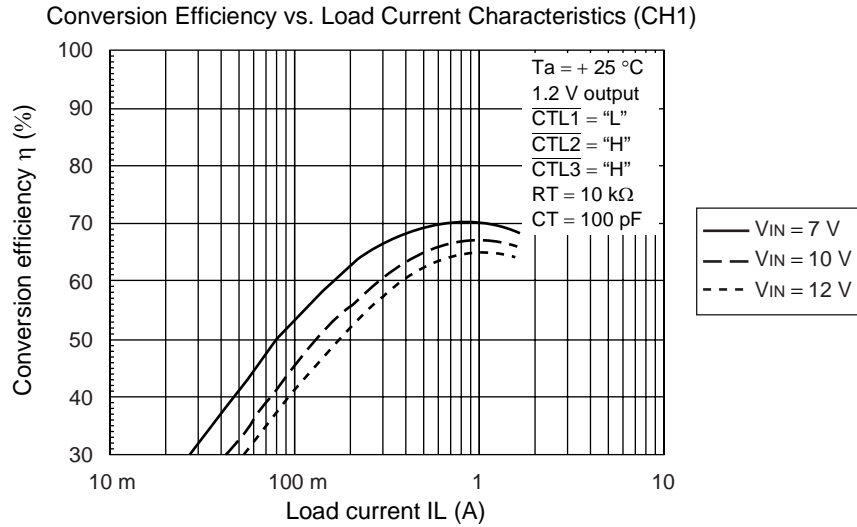

(Continued)

(Continued)

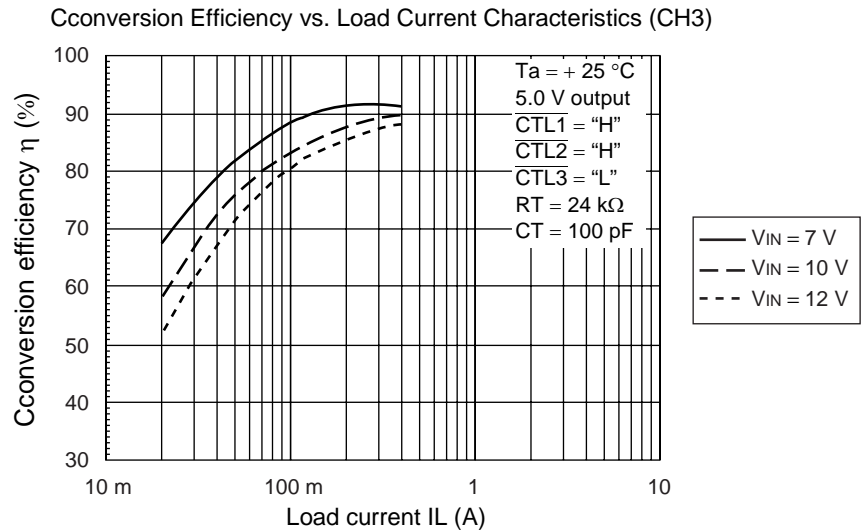
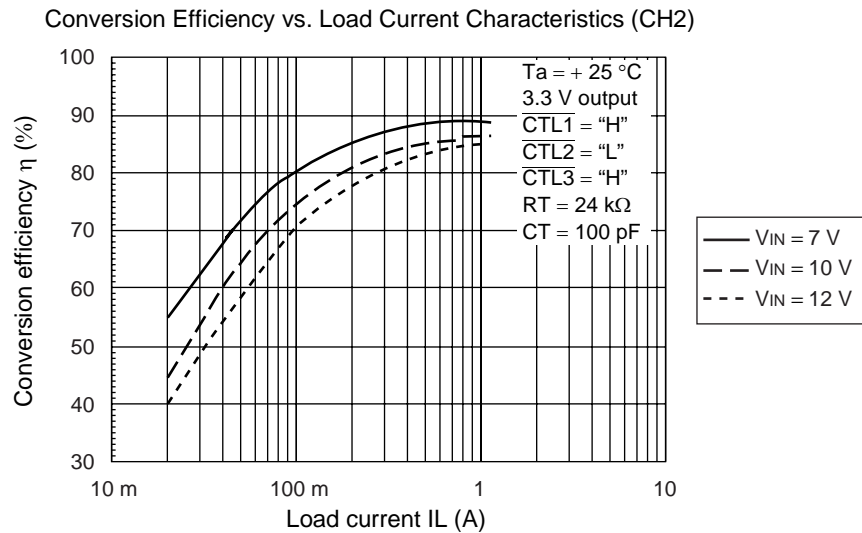
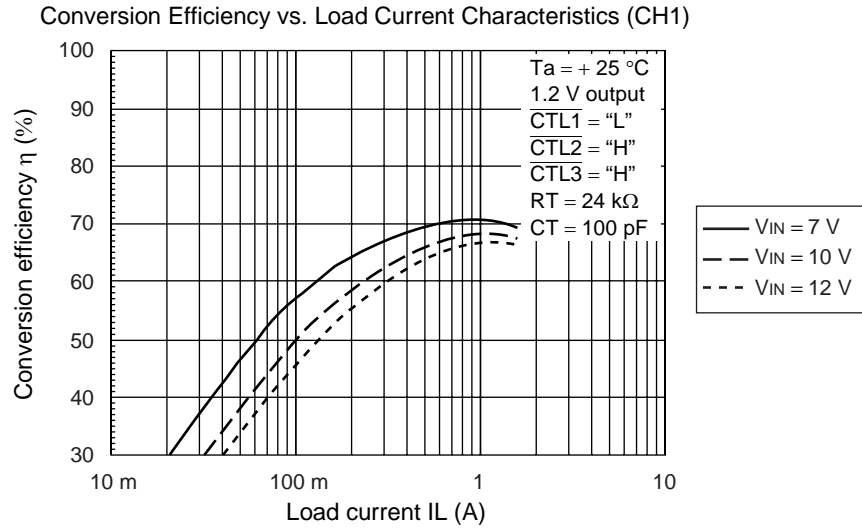

■ USAGE PRECAUTION

- Printed circuit board ground lines should be set up with consideration for common impedance.
- Take appropriate static electricity measures.
 - Containers for semiconductor materials should have anti-static protection or be made of conductive material.
 - After mounting, printed circuit boards should be stored and shipped in conductive bags or containers.
 - Work platforms, tools and instruments should be properly grounded.
 - Working personnel should be grounded with resistance of 250 k Ω to 1 M Ω between body and ground.
- Do not apply negative voltages.
 - The use of negative voltages below -0.3 V may create parasitic transistors on LSI lines, which can cause abnormal operation.

■ ORDERING INFORMATION

Part number	Package	Remarks
MB39A112PFT	20-pin plastic TSSOP (FPT-20P-M06)	

MB39A112

■ PACKAGE DIMENSION

20-pin plastic TSSOP
(FPT-20P-M06)

Note 1) *1 : Resin protrusion. (Each side : +0.15 (.006) Max) .
 Note 2) *2 : These dimensions do not include resin protrusion.
 Note 3) Pins width and pins thickness include plating thickness.
 Note 4) Pins width do not include tie bar cutting remainder.

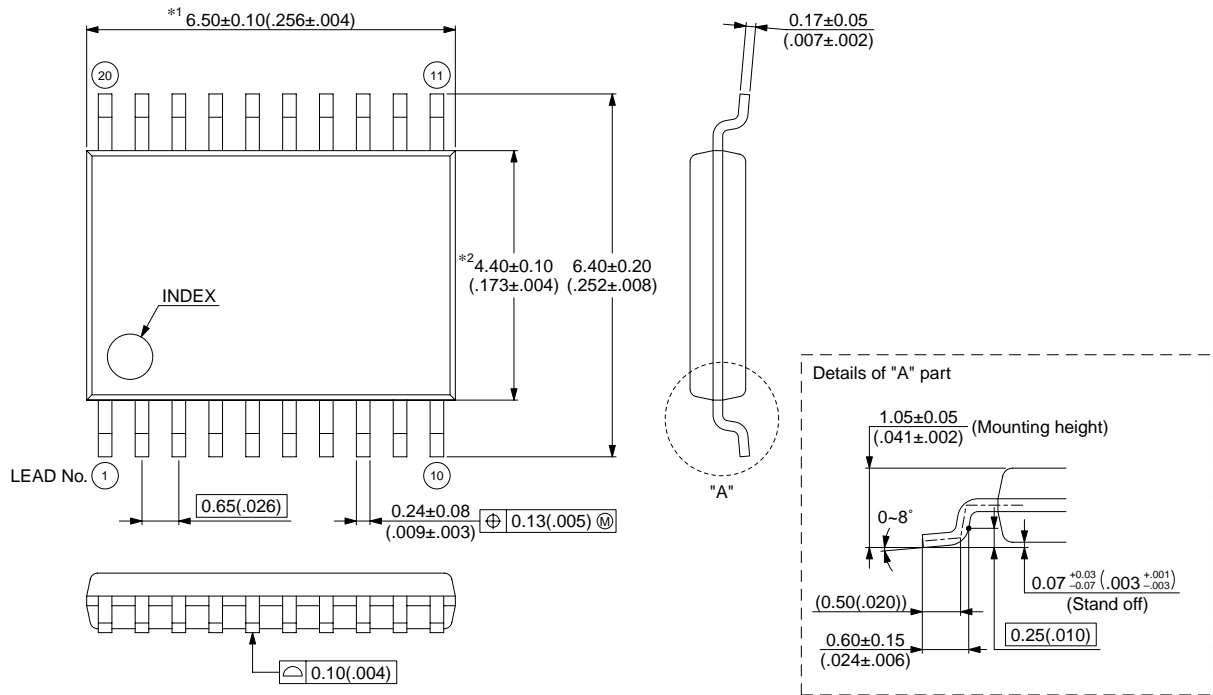

© 2003 FUJITSU LIMITED F20026S-c-3-3

Dimensions in mm (inches) .

Note : The values in parentheses are reference values.

MEMO

FUJITSU MICROELECTRONICS LIMITED

Shinjuku Dai-Ichi Seimei Bldg. 7-1, Nishishinjuku 2-chome, Shinjuku-ku,
Tokyo 163-0722, Japan Tel: +81-3-5322-3347 Fax: +81-3-5322-3387
<http://jp.fujitsu.com/fml/en/>

For further information please contact:

North and South America

FUJITSU MICROELECTRONICS AMERICA, INC.
1250 E. Arques Avenue, M/S 333
Sunnyvale, CA 94085-5401, U.S.A.
Tel: +1-408-737-5600 Fax: +1-408-737-5999
<http://www.fma.fujitsu.com/>

Europe

FUJITSU MICROELECTRONICS EUROPE GmbH
Pittlerstrasse 47, 63225 Langen,
Germany
Tel: +49-6103-690-0 Fax: +49-6103-690-122
<http://emea.fujitsu.com/microelectronics/>

Korea

FUJITSU MICROELECTRONICS KOREA LTD.
206 KOSMO TOWER, 1002 Daechi-Dong,
Kangnam-Gu, Seoul 135-280
Korea
Tel: +82-2-3484-7100 Fax: +82-2-3484-7111
<http://www.fmk.fujitsu.com/>

Asia Pacific

FUJITSU MICROELECTRONICS ASIA PTE LTD.
151 Lorong Chuan, #05-08 New Tech Park,
Singapore 556741
Tel: +65-6281-0770 Fax: +65-6281-0220
<http://www.fujitsu.com/sg/services/micro/semiconductor/>

FUJITSU MICROELECTRONICS SHANGHAI CO., LTD.
Rm.3102, Bund Center, No.222 Yan An Road(E),
Shanghai 200002, China
Tel: +86-21-6335-1560 Fax: +86-21-6335-1605
<http://cn.fujitsu.com/fmc/>

FUJITSU MICROELECTRONICS PACIFIC ASIA LTD.
10/F., World Commerce Centre, 11 Canton Road
Tsimshatsui, Kowloon
Hong Kong
Tel: +852-2377-0226 Fax: +852-2376-3269
<http://cn.fujitsu.com/fmc/tw>

All Rights Reserved.

The contents of this document are subject to change without notice.

Customers are advised to consult with sales representatives before ordering.

The information, such as descriptions of function and application circuit examples, in this document are presented solely for the purpose of reference to show examples of operations and uses of FUJITSU MICROELECTRONICS device; FUJITSU MICROELECTRONICS does not warrant proper operation of the device with respect to use based on such information. When you develop equipment incorporating the device based on such information, you must assume any responsibility arising out of such use of the information.

FUJITSU MICROELECTRONICS assumes no liability for any damages whatsoever arising out of the use of the information.

Any information in this document, including descriptions of function and schematic diagrams, shall not be construed as license of the use or exercise of any intellectual property right, such as patent right or copyright, or any other right of FUJITSU MICROELECTRONICS or any third party or does FUJITSU MICROELECTRONICS warrant non-infringement of any third-party's intellectual property right or other right by using such information. FUJITSU MICROELECTRONICS assumes no liability for any infringement of the intellectual property rights or other rights of third parties which would result from the use of information contained herein.

The products described in this document are designed, developed and manufactured as contemplated for general use, including without limitation, ordinary industrial use, general office use, personal use, and household use, but are not designed, developed and manufactured as contemplated (1) for use accompanying fatal risks or dangers that, unless extremely high safety is secured, could have a serious effect to the public, and could lead directly to death, personal injury, severe physical damage or other loss (i.e., nuclear reaction control in nuclear facility, aircraft flight control, air traffic control, mass transport control, medical life support system, missile launch control in weapon system), or (2) for use requiring extremely high reliability (i.e., submersible repeater and artificial satellite).

Please note that FUJITSU MICROELECTRONICS will not be liable against you and/or any third party for any claims or damages arising in connection with above-mentioned uses of the products.

Any semiconductor devices have an inherent chance of failure. You must protect against injury, damage or loss from such failures by incorporating safety design measures into your facility and equipment such as redundancy, fire protection, and prevention of over-current levels and other abnormal operating conditions.

Exportation/release of any products described in this document may require necessary procedures in accordance with the regulations of the Foreign Exchange and Foreign Trade Control Law of Japan and/or US export control laws.

The company names and brand names herein are the trademarks or registered trademarks of their respective owners.