

ASSP For Power Supply Applications (DC/DC Converter for DSC/Camcorder)

4-ch DC/DC Converter IC with Synchronous Rectification

MB39A110

■ DESCRIPTION

The MB39A110 is a 4-channel DC/DC converter IC using pulse width modulation (PWM). This IC is ideal for up conversion, down conversion, and up/down conversion.

This is built-in 4 ch in TSSOP-38P package and operates at 2 MHz Max. Each channel can be controlled, and soft-start.

This is an ideal power supply for high-performance portable devices such as digital still cameras.

This product is covered by US Patent Number 6,147,477.

■ FEATURES

- Supports for down-conversion and up/down Zeta conversion (CH1 to CH3)
- Supports for up-conversion and up/down Sepic conversion (CH4)
- For synchronous rectification (CH1, CH2)
- Power supply voltage range : 2.5 V to 11 V
- Reference voltage : 2.0 V \pm 1 %
- Error amplifier threshold voltage : 1.23 V \pm 1%
- High-frequency operation capability: 2 MHz (Max)
- Standby current : 0 μ A (Typ)
- Built-in soft-start circuit independent of loads
- Built-in totem-pole type output for MOS FET
- Short-circuit detection capability by external signal (-INS terminal)
- One type of package (TSSOP-38 pin : 1 type)

■ APPLICATIONS

- Digital still camera(DSC)
- Digital video camera(DVC)
- Surveillance camera etc.

MB39A110

■ PIN ASSIGNMENT

(TOP VIEW)

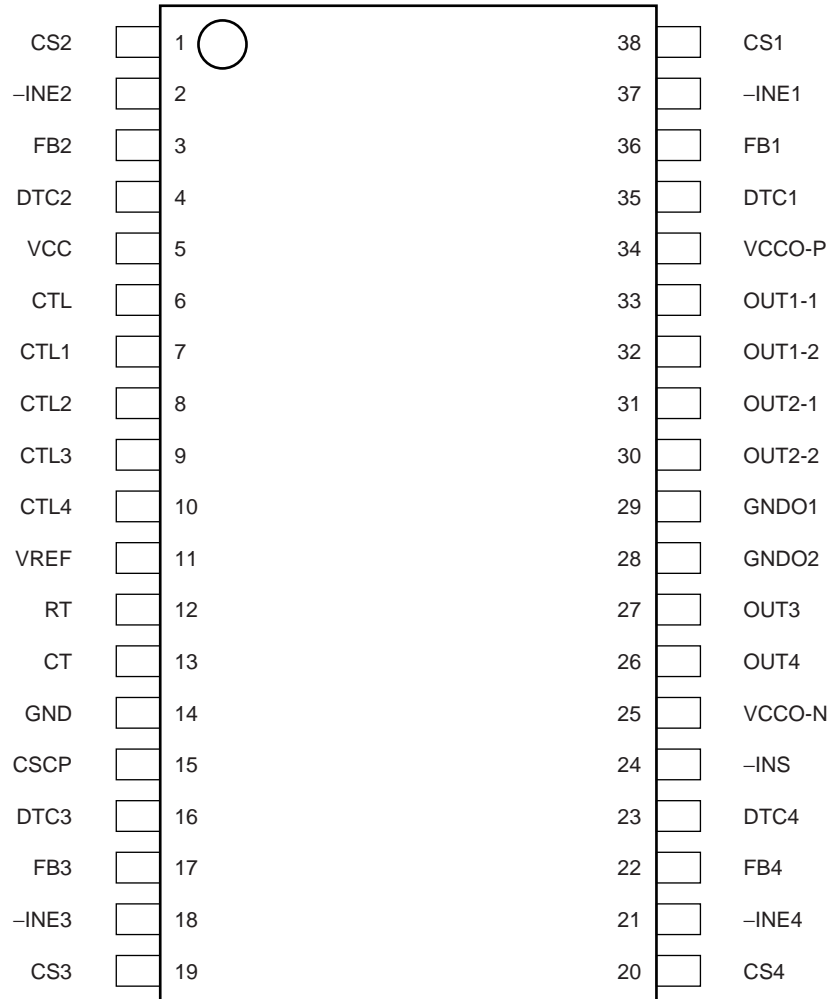

(FPT-38P-M03)

■ PIN DESCRIPTION

Block	Pin No.	Symbol	I/O	Descriptions
CH1	35	DTC1	I	Dead time control terminal
	36	FB1	O	Error amplifier output terminal
	37	-INE1	I	Error amplifier inverted input terminal
	38	CS1	—	Soft-start setting capacitor connection terminal
	33	OUT1-1	O	P-ch drive output block ground terminal (External main side FET gate driving)
	32	OUT1-2	O	N-ch drive output block ground terminal (External synchronous rectification side FET gate driving)
CH2	4	DTC2	I	Dead time control terminal
	3	FB2	O	Error amplifier output terminal
	2	-INE2	I	Error amplifier inverted input terminal
	1	CS2	—	Soft-start setting capacitor connection terminal
	31	OUT2-1	O	P-ch drive output block ground terminal (External main side FET gate driving)
	30	OUT2-2	O	N-ch drive output block ground terminal (External synchronous rectification side FET gate driving)
CH3	16	DTC3	I	Dead time control terminal
	17	FB3	O	Error amplifier output terminal
	18	-INE3	I	Error amplifier inverted input terminal
	19	CS3	—	Soft-start setting capacitor connection terminal
	27	OUT3	O	P-ch drive output terminal
CH4	23	DTC4	I	Dead time control terminal
	22	FB4	O	Error amplifier output terminal
	21	-INE4	I	Error amplifier inverted input terminal
	20	CS4	—	Soft-start setting capacitor connection terminal
	26	OUT4	O	N-ch drive output terminal
OSC	13	CT	—	Triangular wave frequency setting capacitor connection terminal
	12	RT	—	Triangular wave frequency setting resistor connection terminal

(Continued)

MB39A110

(Continued)

Block	Pin No.	Symbol	I/O	Descriptions
Control	6	CTL	I	Power supply control terminal
	7	CTL1	I	Control terminal
	8	CTL2	I	Control terminal
	9	CTL3	I	Control terminal
	10	CTL4	I	Control terminal
	15	CSCP	—	Short-circuit detection circuit capacitor connection terminal
	24	-INS	I	Short-circuit detection comparator inverted input terminal
Power	34	VCCO-P	—	P-ch drive output block power supply terminal
	25	VCCO-N	—	N-ch drive output block power supply terminal
	5	VCC	—	Power supply terminal
	11	VREF	O	Reference voltage output terminal
	29	GNDO1	—	Drive output block ground terminal
	28	GNDO2	—	Drive output block ground terminal
	14	GND	—	Ground terminal

■ BLOCK DIAGRAM

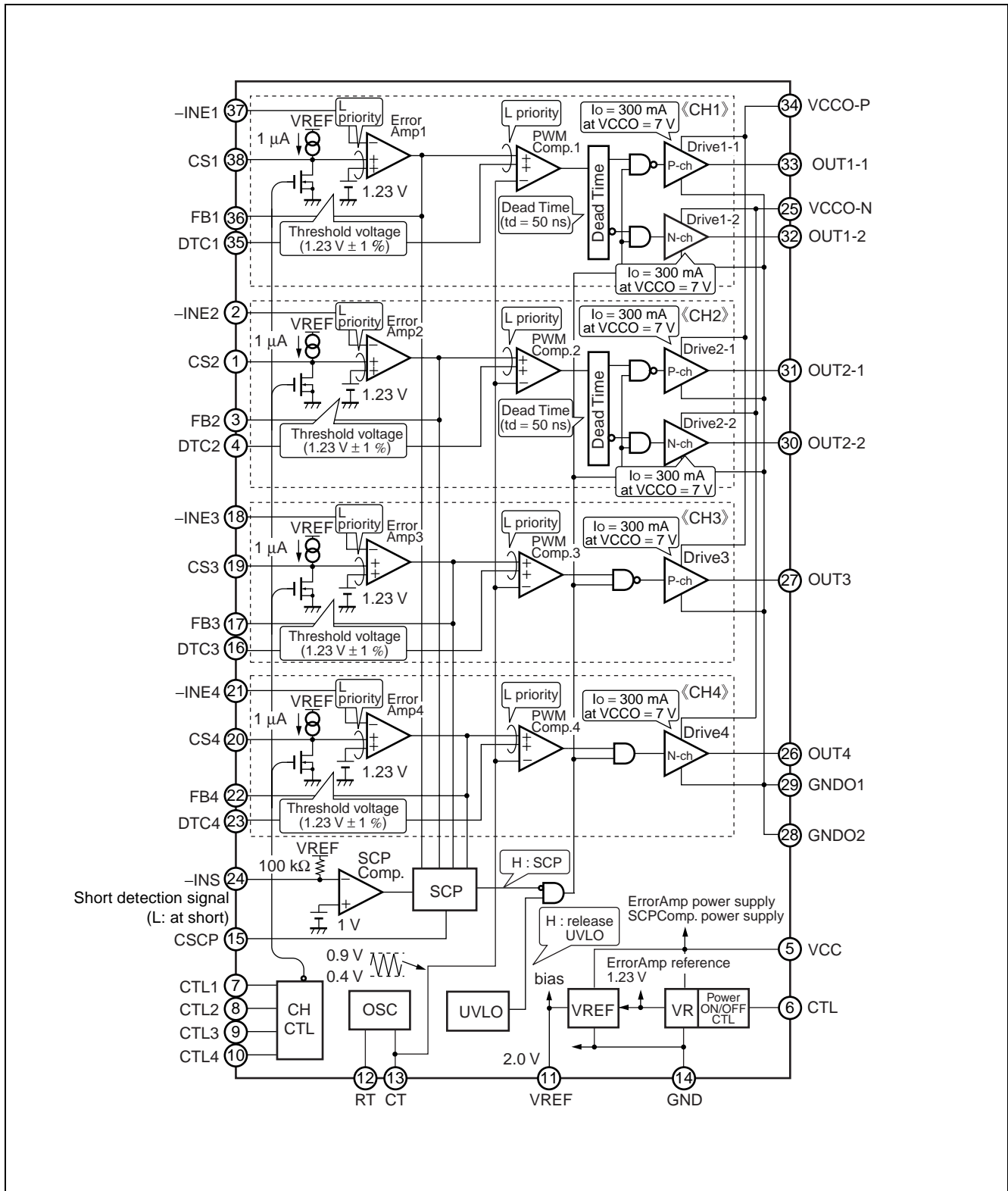

MB39A110

■ ABSOLUTE MAXIMUM RATINGS

Parameter	Symbol	Condition	Rating		Unit
			Min	Max	
Power supply voltage	V _{CC}	VCC, VCCO terminal	—	12	V
Output current	I _o	OUT1 to OUT4 terminal	—	20	mA
Peak output current	I _{OP}	OUT1 to OUT4 terminal, Duty ≤ 5% (t = 1 / f _{osc} × Duty)	—	400	mA
Power dissipation	P _D	T _a ≤ +25 °C	—	1680*	mW
Storage temperature	T _{STG}	—	-55	+125	°C

* : The packages are mounted on the epoxy board (10 cm × 10 cm).

WARNING: Semiconductor devices can be permanently damaged by application of stress (voltage, current, temperature, etc.) in excess of absolute maximum ratings. Do not exceed these ratings.

■ RECOMMENDED OPERATING CONDITIONS

Parameter	Symbol	Condition	Value			Unit
			Min	Typ	Max	
Power supply voltage	V _{CC}	VCC, VCCO terminal	2.5	7	11	V
Reference voltage output current	I _{REF}	VREF terminal	-1	—	0	mA
Input voltage	V _{INE}	-INE1 to -INE4 terminal	0	—	V _{CC} - 0.9	V
		-INS terminal	0	—	V _{REF}	V
	V _{DTC}	DTC1 to DTC4 terminal	0	—	V _{REF}	V
Control input voltage	V _{CTL}	CTL terminal	0	—	11	V
Output current	I _o	OUT1 to OUT4 terminal	-15	—	+15	mA
Oscillation frequency	f _{OSC}	—	0.2	1.02	2.0	kHz
Timing capacitor	C _T	—	27	100	680	pF
Timing resistor	R _T	—	3.0	6.8	39	kΩ
Soft-start capacitor	C _S	CS1 to CS4 terminal	—	0.1	1.0	μF
Short-circuit detection capacitor	C _{SCP}	—	—	0.1	1.0	μF
Reference voltage output capacitor	C _{REF}	—	—	0.1	1.0	μF
Operating ambient temperature	T _a	—	-30	+25	+85	°C

WARNING: The recommended operating conditions are required in order to ensure the normal operation of the semiconductor device. All of the device's electrical characteristics are warranted when the device is operated within these ranges.

Always use semiconductor devices within their recommended operating condition ranges. Operation outside these ranges may adversely affect reliability and could result in device failure.

No warranty is made with respect to uses, operating conditions, or combinations not represented on the data sheet. Users considering application outside the listed conditions are advised to contact their representatives beforehand.

■ ELECTRICAL CHARACTERISTICS

(VCC = VCCO = 7 V, Ta = +25 °C)

Parameter	Sym- bol	Pin No	Conditions	Value			Unit	
				Min	Typ	Max		
1. Reference voltage block [VREF]	Output voltage	VREF1	11	VREF = 0 mA	1.98	2.00	2.02	V
		VREF2	11	VCC = 2.5 V to 11 V	1.975	2.000	2.025	V
		VREF3	11	VREF = 0 mA to -1 mA	1.975	2.000	2.025	V
	Input stability	Line	11	VCC = 2.5 V to 11 V	—	2*	—	mV
	Load stability	Load	11	VREF = 0 mA to -1 mA	—	2*	—	mV
	Temperature stability	$\Delta V_{REF} / V_{REF}$	11	Ta = 0 °C to +85 °C	—	0.20*	—	%
	Output current at short-circuit	I _{OS}	11	VREF = 0 V	—	-300*	—	mA
2. Under voltage lockout protection circuit block [UVLO]	Threshold voltage	V _{TH}	33	VCC = $\underline{\text{J}}$	1.7	1.8	1.9	V
	Hysteresis width	V _H	33	—	0.05	0.1	—	V
	Reset voltage	V _{RST}	33	VREF = $\underline{\text{L}}$	1.5	1.7	1.85	V
3. Short-circuit detection block [SCP]	Threshold voltage	V _{TH}	15	—	0.65	0.70	0.75	V
	Input source current	I _{CS}	15	—	-1.4	-1.0	-0.6	μA
4. Triangular wave oscillator block [OSC]	Oscillation frequency	f _{OSC1}	26, 27, 30 to 33	C _T = 100 pF, R _T = 6.8 kΩ	0.97	1.02	1.07	MHz
		f _{OSC2}	26, 27, 30 to 33	C _T = 100 pF, R _T = 6.8 kΩ, VCC = 2.5 V to 11 V	0.964	1.02	1.076	MHz
	Frequency input stability	$\Delta f_{OSC} / f_{OSC}$	26, 27, 30 to 33	C _T = 100 pF, R _T = 6.8 kΩ, VCC = 2.5 V to 11 V	—	1.0*	—	%
	Frequency temperature stability	$\Delta f_{OSC} / f_{OSC}$	26, 27, 30 to 33	C _T = 100 pF, R _T = 6.8 kΩ, Ta = 0 °C to +85 °C	—	1.0*	—	%
5. Soft-start block [CS1 to CS4]	Charge current	I _{CS}	1, 19, 20, 38	CS1 to CS4 = 0 V	-1.4	-1.0	-0.6	μA

* : Standard design value

(Continued)

MB39A110

(VCC = VCCO = 7 V, Ta = +25 °C)

Parameter	Symbol	Pin No	Conditions	Value			Unit	
				Min	Typ	Max		
6. Error amplifier block [Error Amp1 to Error Amp4]	Threshold voltage	V _{TH1}	2, 18, 21, 37	V _{CC} = 2.5 V to 11 V, Ta = +25 °C	1.217	1.230	1.243	V
		V _{TH2}	2, 18, 21, 37	V _{CC} = 2.5 V to 11 V, Ta = 0 °C to +85 °C	1.215	1.230	1.245	V
	Temperature stability	$\Delta V_{TH}/V_{TH}$	2, 18, 21, 37	Ta = 0 °C to +85 °C	—	0.1*	—	%
	Input bias current	I _B	2, 18, 21, 37	-INE1 to -INE4 = 0 V	-120	-30	—	nA
	Voltage gain	A _V	3, 17, 22, 36	DC	—	100*	—	dB
	Frequency bandwidth	BW	3, 17, 22, 36	A _V = 0 dB	—	1.4*	—	MHz
	Output voltage	V _{OH}	3, 17, 22, 36	—	1.7	1.9	—	V
		V _{OL}	3, 17, 22, 36	—	—	40	200	mV
	Output source current	I _{SOURCE}	3, 17, 22, 36	FB1 to FB4 = 0.65 V	—	-2	-1	mA
Output sink current	I _{SINK}	3, 17, 22, 36	FB1 to FB4 = 0.65 V	150	200	—	μA	
7. PWM comparator block [PWM Comp.1 to PWM Comp.4]	Threshold voltage	V _{T0}	26, 27, 30 to 33	Duty cycle = 0%	0.3	0.4	—	V
		V _{T100}	26, 27, 30 to 33	Duty cycle = 100%	0.85	0.90	0.95	V
	Input current	I _{DTC}	4, 16, 23, 35	DTC = 0.4 V	-2.0	-0.6	—	μA
8. Output block [Drive1 to Drive4]	Output source current	I _{SOURCE}	26, 27, 30 to 33	Duty ≤ 5% (t = 1 / f _{osc} × Duty) , OUT1 to OUT4 = 0 V	—	-300*	—	mA
	Output sink current	I _{SINK}	26, 27, 30 to 33	Duty ≤ 5% (t = 1 / f _{osc} × Duty) , OUT1 to OUT4 = 7 V	—	300*	—	mA
	Output ON resistor	R _{OH}	26, 27, 30 to 33	OUT1 to OUT4 = -15 mA	—	9	14	Ω
		R _{OL}	26, 27, 30 to 33	OUT1 to OUT4 = 15 mA	—	9	14	Ω
	Dead time	t _{D1}	30 to 33	OUT2 $\overline{\text{OUT1}}$	—	50*	—	ns
t _{D2}		30 to 33	OUT1 $\overline{\text{OUT2}}$	—	50*	—	ns	
9. Short-circuit detection comparator block [SCP Comp.]	Threshold voltage	V _{TH}	33	—	0.97	1.00	1.03	V
	Input bias current	I _B	24	-INS = 0 V	-25	-20	-17	μA

*: Standard design value

(Continued)

(Continued)

(VCC = VCCO = 7 V, Ta = +25 °C)

Parameter		Symbol	Pin No	Conditions	Value			Unit
					Min	Typ	Max	
10. Control block [CTL, CHCTL]	Output ON conditions	V _{IH}	6, 7 to 10	CTL, CTL1 to CTL4	2	—	11	V
	Output OFF conditions	V _{IL}	6, 7 to 10	CTL, CTL1 to CTL4	0	—	0.8	V
	Input current	I _{CTLH}	6, 7 to 10	CTL, CTL1 to CTL4 = 3 V	—	30	60	μA
		I _{CTL}	6, 7 to 10	CTL, CTL1 to CTL4 = 0 V	—	—	1	μA
11. General	Standby current	I _{CCS}	5	CTL, CTL1 to CTL4 = 0 V	—	0	2	μA
		I _{CCSO}	25, 34	CTL = 0 V	—	0	1	μA
	Power supply current	I _{CC}	5	CTL = 3 V	—	3	4.5	mA

*: Standard design value

TYPICAL CHARACTERISTICS

Power Supply Current vs. Power Supply Voltage

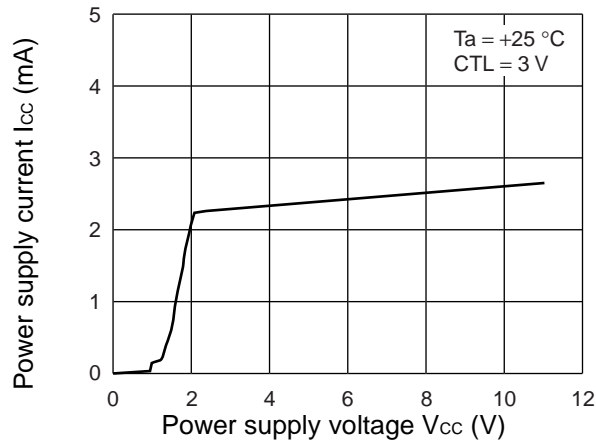

Reference Voltage vs. Power Supply Voltage

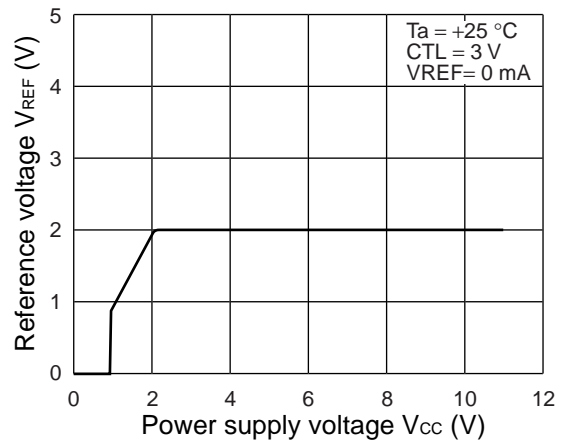

Reference Voltage vs. Ambient Temperature

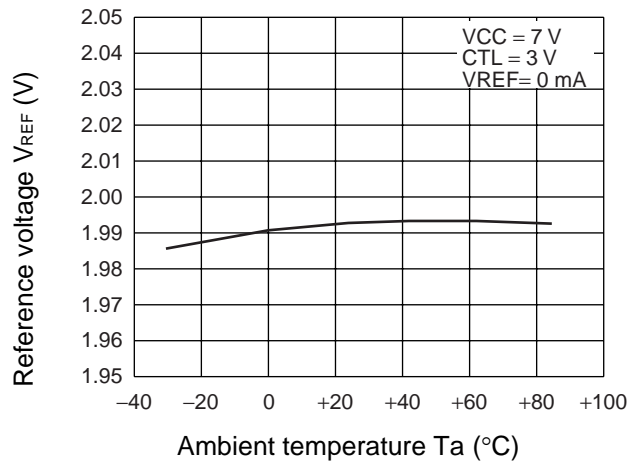

Reference Voltage vs. CTL terminal Voltage

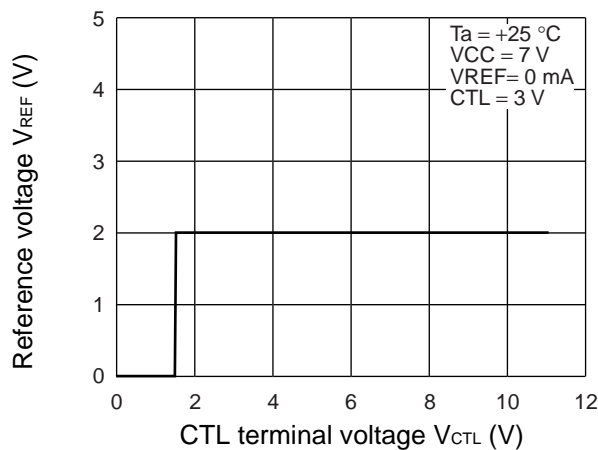

CTL terminal Current vs. CTL terminal Voltage

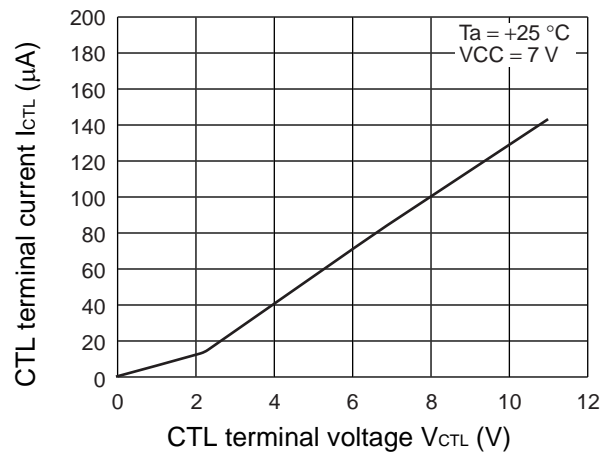

(Continued)

Triangular Wave Oscillation Frequency vs. Timing Resistor

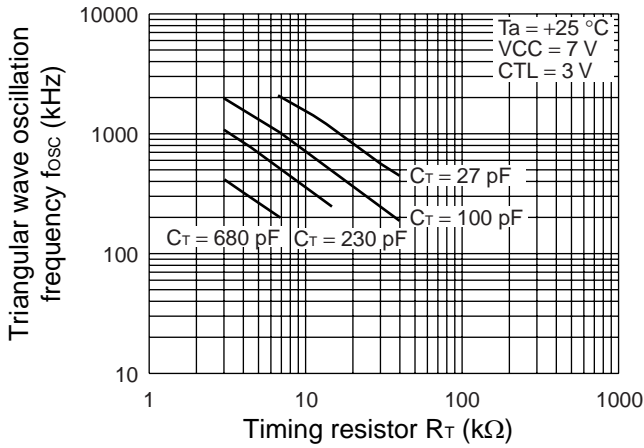

Triangular Wave Oscillation Frequency vs. Timing Capacitor

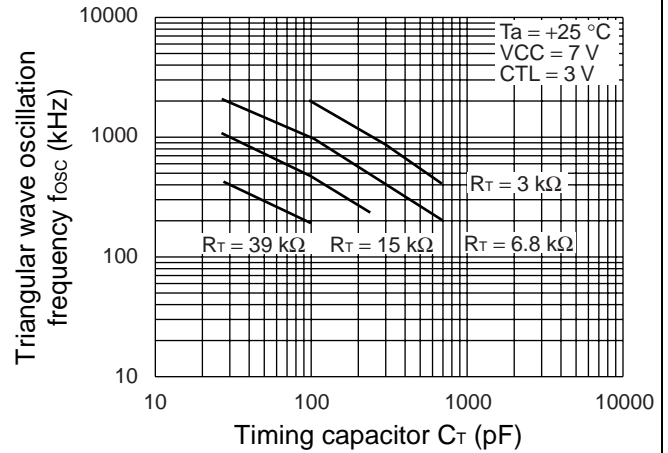

Triangular Wave Upper and Lower Limit Voltage vs. Triangular Wave Oscillation Frequency

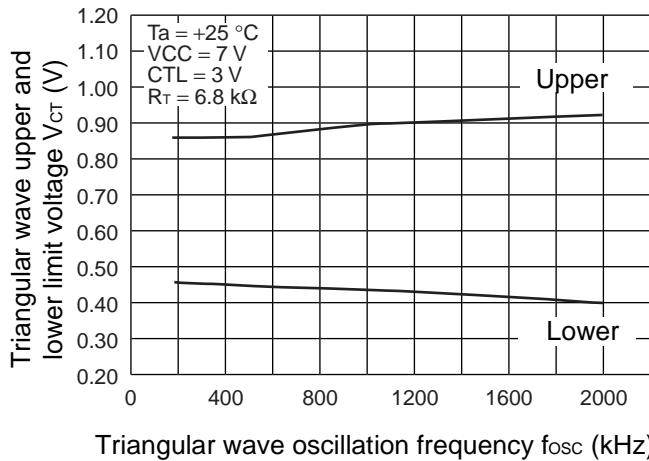

Triangular Wave Upper and Lower Limit Voltage vs. Ambient Temperature

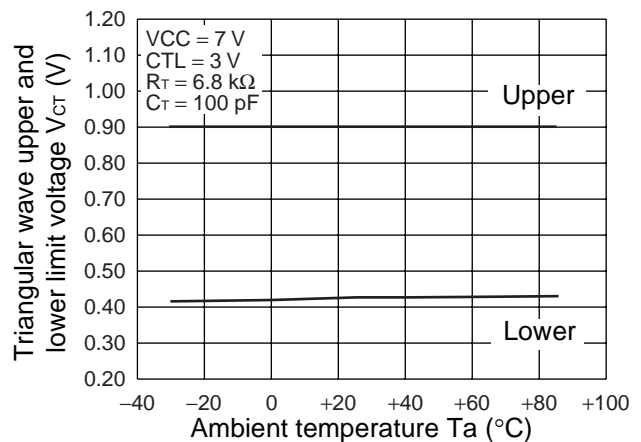

Triangular Wave Oscillation Frequency vs. Ambient Temperature

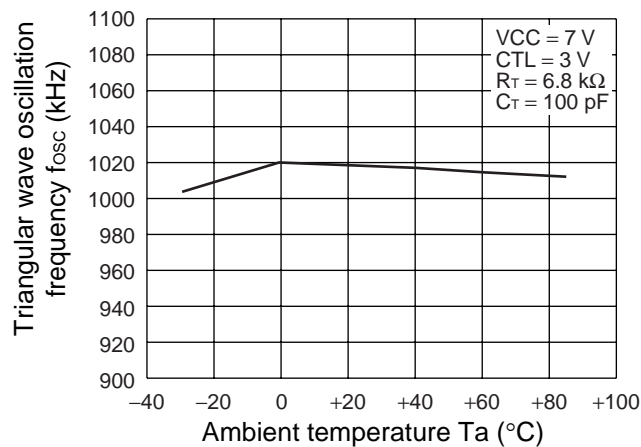

(Continued)

MB39A110

(Continued)

Error Amplifier Gain, Phase vs. Frequency

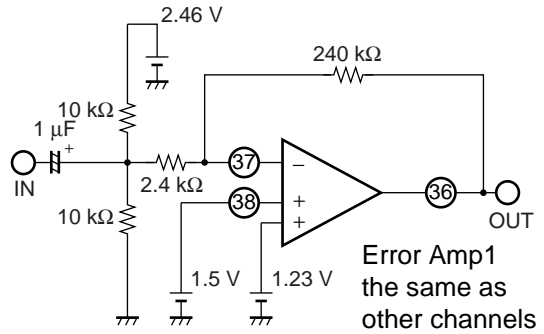
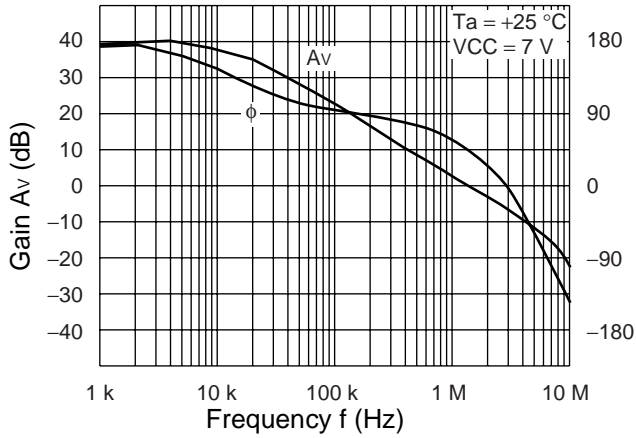

Power Dissipation vs. Ambient Temperature

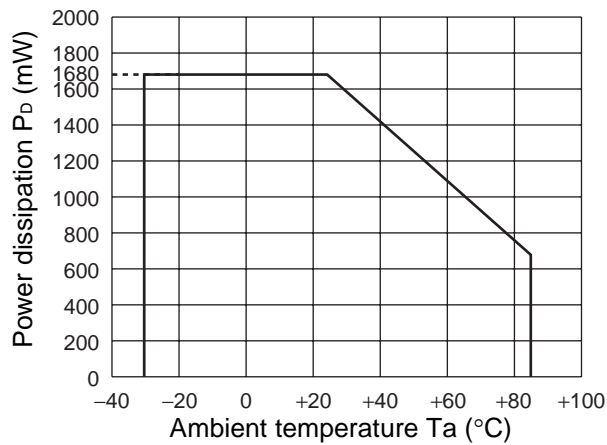

■ FUNCTION DESCRIPTION

1. DC/DC Converter Functions

(1) Reference Voltage Block (VREF)

The reference voltage circuit generates a temperature-compensated reference voltage (2.0 V Typ) from the voltage supplied from the power supply terminal (pin 5). The voltage is used as the reference voltage for the IC's internal circuit.

The reference voltage can supply a load current of up to 1 mA to an external device through the VREF terminal (pin 11).

(2) Triangular-wave Oscillator Block (OSC)

The triangular wave oscillator incorporates a timing capacitor and a timing resistor connected respectively to the CT terminal (pin 13) and RT terminal (pin 12) to generate triangular oscillation waveform amplitude of 0.4 V to 0.9 V.

The triangular waveforms are input to the PWM comparator in the IC.

(3) Error Amplifier Block (Error Amp1 to Error Amp4)

The error amplifier detects the DC/DC converter output voltage and outputs PWM control signals. In addition, an arbitrary loop gain can be set by connecting a feedback resistor and capacitor from the output terminal to inverted input terminal of the error amplifier, enabling stable phase compensation to the system.

Also, it is possible to prevent rush current at power supply start-up by connecting a soft-start capacitor with the CS1 terminal (pin 38) to CS4 terminal (pin 20) which are the non-inverted input terminal for Error Amp. The use of Error Amp for soft-start detection makes it possible for a system to operate on a fixed soft-start time that is independent of the output load on the DC/DC converter.

(4) PWM Comparator Block (PWM Comp.1 to PWM Comp.4)

The PWM comparator is a voltage-to-pulse width modulator that controls the output duty depending on the input/output voltage.

The output transistor turns on while the error amplifier output voltage and DTC voltage remain higher than the triangular wave voltage.

(5) Output Block (Drive1 to Drive 4)

The output block is in the totem pole type, capable of driving an external P-ch MOS FET (channel 1 and 2 main side and channel 3), and N-ch MOS FET (channel 1 and 2 synchronous rectification side and channel 4).

2. Channel Control Function

The main or each channel is turned on and off depending on the voltage levels at the CTL terminal (pin 6), CS1 terminal (pin 38), CS2 terminal (pin 1), CS3 terminal (pin 19), and CS4 terminal (pin 20).

Channel On/Off Setting Conditions

CTL	CTL1	CTL2	CTL3	CTL4	Power	CH1	CH2	CH3	CH4
L	—*	—*	—*	—*	OFF	OFF	OFF	OFF	OFF
<u>H</u>	L	L	L	L	<u>ON</u>	OFF	OFF	OFF	OFF
<u>H</u>	<u>H</u>	L	L	L	<u>ON</u>	<u>ON</u>	OFF	OFF	OFF
<u>H</u>	L	<u>H</u>	L	L	<u>ON</u>	OFF	<u>ON</u>	OFF	OFF
<u>H</u>	L	L	<u>H</u>	L	<u>ON</u>	OFF	OFF	<u>ON</u>	OFF
<u>H</u>	L	L	L	<u>H</u>	<u>ON</u>	OFF	OFF	OFF	<u>ON</u>
<u>H</u>	<u>H</u>	<u>H</u>	<u>H</u>	<u>H</u>	<u>ON</u>	<u>ON</u>	<u>ON</u>	<u>ON</u>	<u>ON</u>

* : Undefined

Note : Note that current over stand-by current flows into VCC terminal when the CTL terminal is in “L” level and one of terminals between CTL1 and CTL4 is set to “H” level. (Refer to “■ I/O EQUIVALENT CIRCUIT”.)

3. Protective Functions

(1) Timer-latch short-circuit protection circuit (SCP, SCP Comp.)

The short-circuit detection comparator (SCP) detects the output voltage level of each channel, and if any channel output voltage becomes the short-circuit detection voltage or less, the timer circuits are actuated to start charging the external capacitor C_{SCP} connected to the CSCP terminal (pin 15).

When the capacitor (C_{SCP}) voltage reaches about 0.7 V, the circuit is turned off the output transistor and sets the dead time to 100 %.

In addition, the short-circuit detection from external input is capable by using –INS terminal (pin 24) on short-circuit detection comparator (SCP Comp.) .

To release the actuated protection circuit, either turn the power supply off and on again or set the CTL terminal (pin 6) to the “L” level to lower the VREF terminal (pin 11) voltage to 1.5 V (Min) or less. (Refer to “■SETTING TIME CONSTANT FOR TIMER-LATCH SHORT-CIRCUIT PROTECTION CIRCUIT”.)

(2) Under voltage lockout protection circuit (UVLO)

The transient state or a momentary decrease in supply voltage, which occurs when the power supply is turned on, may cause the IC to malfunction, resulting in breakdown or degradation of the system. To prevent such malfunctions, under voltage lockout protection circuit detects a decrease in internal reference voltage with respect to the power supply voltage, turn off the output transistor, and set the dead time to 100% while holding the CSCP terminal (pin 15) at the “L” level.

The circuit restores the output transistor to normal when the supply voltage reaches the threshold voltage of the undervoltage lockout protection circuit.

■ PROTECTION CIRCUIT OPERATING FUNCTION TABLE

This table refers to output condition when protection circuit is operating.

Operating circuit	OUT1-1	OUT1-2	OUT2-1	OUT2-2	OUT3	OUT4
Short-circuit protection circuit	<u>H</u>	L	<u>H</u>	L	<u>H</u>	L
Under voltage lockout protection circuit	<u>H</u>	L	<u>H</u>	L	<u>H</u>	L

■ SETTING THE OUTPUT VOLTAGE

• CH1 to CH4

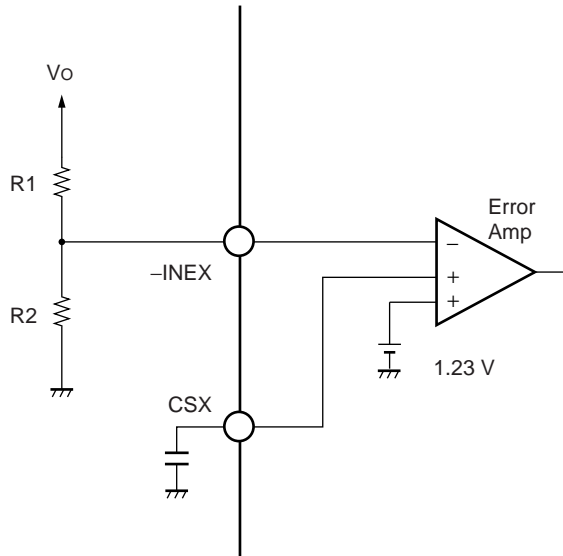

$$V_o (V) = \frac{1.23}{R_2} (R_1 + R_2)$$

X: Each channel No.

■ SETTING THE TRIANGULAR OSCILLATION FREQUENCY

The triangular oscillation frequency is determined by the timing resistor (R_T) connected to the RT terminal (pin 12), and the timing capacitor (C_T) connected to the CT terminal (pin 13).

Triangular oscillation frequency : f_{osc}

$$f_{osc} \text{ (kHz)} \doteq \frac{693600}{C_T \text{ (pF)} \times R_T \text{ (k}\Omega\text{)}}$$

■ SETTING THE SOFT-START TIME

To prevent rush currents when the IC is turned on, you can set a soft-start by connecting soft-start capacitors (C_{S1} to C_{S4}) to the CS1 terminal (pin 38) to the CS4 terminal (pin 20), respectively.

Setting each CTLX from “L” to “H” switches to charge the external soft-start capacitors (C_{S1} to C_{S4}) connected to the CS1 to CS4 terminals at $1 \mu\text{A}$.

The error amplifier output (FB1 to FB4) is determined by comparison between the lower one of the potentials at two non-inverted input terminals (1.23 V , CS terminal voltages) and the inverted input terminal voltage ($-\text{INE1}$ to $-\text{INE4}$).

The FB terminal voltage during the soft-start period (CS terminal voltage $< 1.23 \text{ V}$) is therefore determined by comparison between the $-\text{INE}$ terminal and CS terminal voltages. The DC/DC converter output voltage rises in proportion to the CS terminal voltage as the soft-start capacitor connected to the CS terminal is charged.

The soft-start time is obtained from the following formula:

Soft-start time: t_s (time to output 100%)

$$t_s (\text{s}) \approx 1.23 \times C_{sx} (\mu\text{F})$$

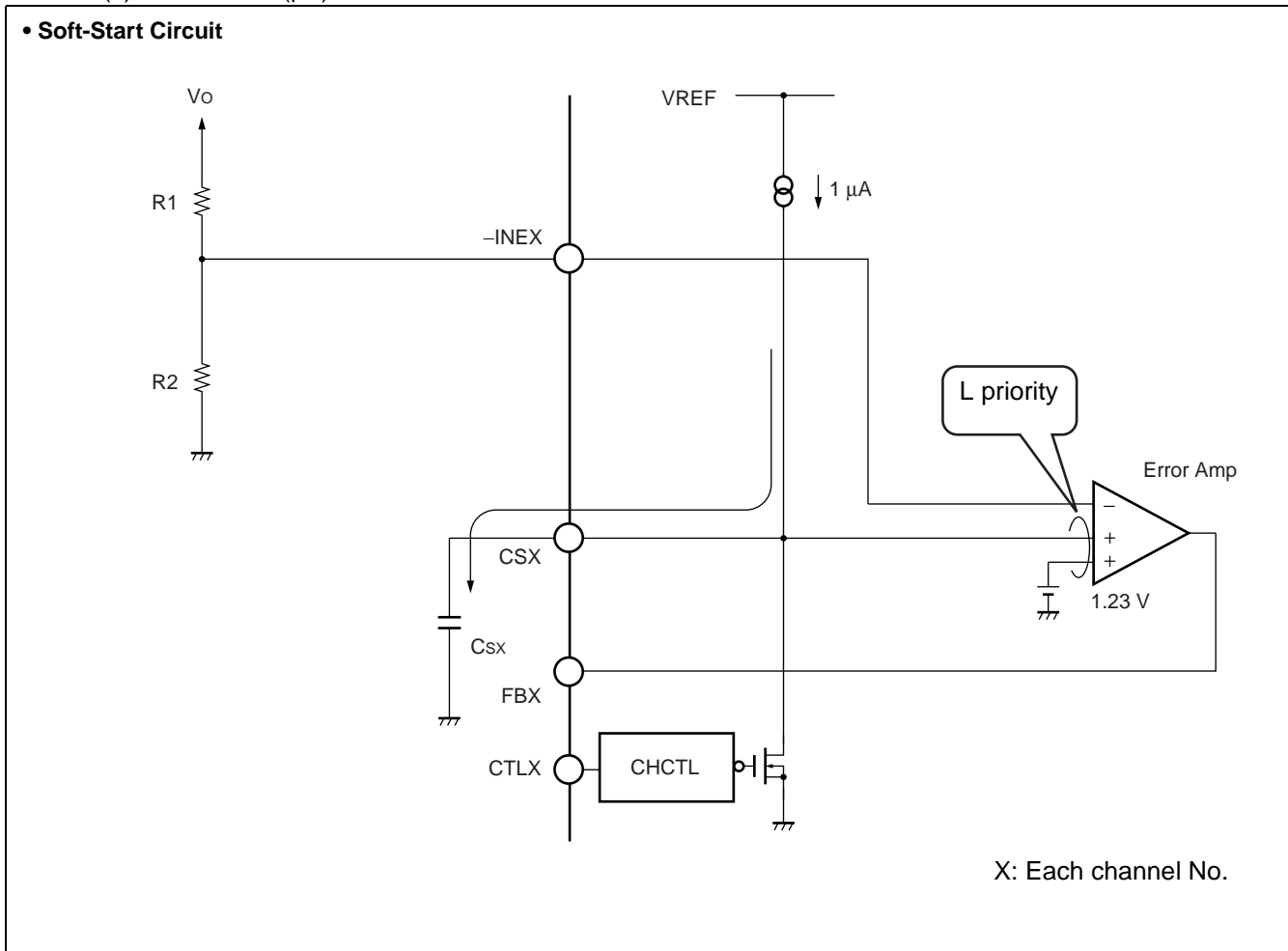

■ TREATMENT WITHOUT USING CS TERMINAL

When not using the soft-start function, open the CS1 terminal (pin 38), the CS2 terminal (pin 1), the CS3 terminal (pin 19), the CS4 terminal (pin 20).

• Without Setting Soft-Start Time

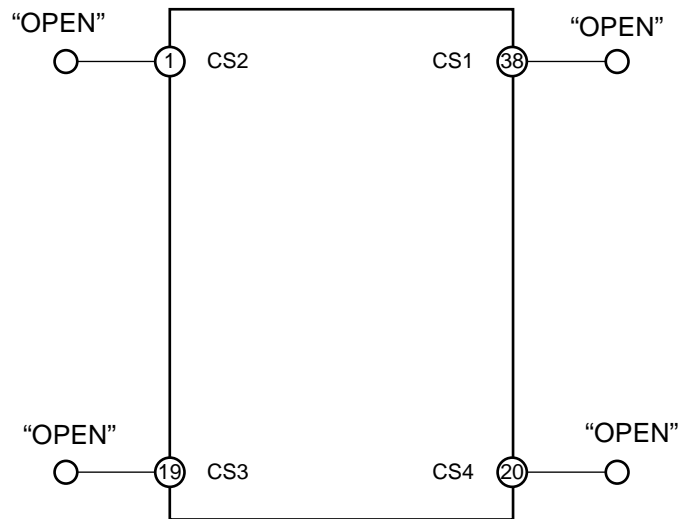

■ SETTING TIME CONSTANT FOR TIMER-LATCH SHORT-CIRCUIT PROTECTION CIRCUIT

Each channel uses the short-circuit detection comparator (SCP) to always compare the error amplifier's output level to the reference voltage.

While DC/DC converter load conditions are stable on all channels, the short-circuit detection comparator output remains at "L" level, and the CSCP terminal (pin 15) is held at "L" level.

If the load condition on a channel changes rapidly due to a short-circuit of the load, causing the output voltage to drop, the output of the short-circuit detection comparator on that channel goes to "H" level. This causes the external short-circuit protection capacitor C_{SCP} connected to the CSCP terminal to be charged at $1 \mu\text{A}$.

Short-circuit detection time : t_{CSCP}

$$t_{CSCP} \text{ (s)} \approx 0.70 \times C_{SCP} \text{ (\mu F)}$$

When the capacitor C_{SCP} is charged to the threshold voltage ($V_{TH} \approx 0.70 \text{ V}$), the latch is set and the external FET is turned off (dead time is set to 100%). At this time, the latch input is closed and the CSCP terminal (pin 15) is held at "L" level.

In addition, the short-circuit detection from external input is capable by using $-\text{INS}$ terminal (pin 24) on the short-circuit detection comparator (SCP Comp.). The short-circuit detection operation starts when $-\text{INS}$ terminal voltage is less than threshold voltage ($V_{TH} \approx 1 \text{ V}$).

When the power supply is turn off and on again or V_{REF} terminal (pin 11) voltage is less than 1.5 V (Min) by setting CTL terminal (pin 6) to "L" level, the latch is released.

• Timer-latch short-circuit protection circuit

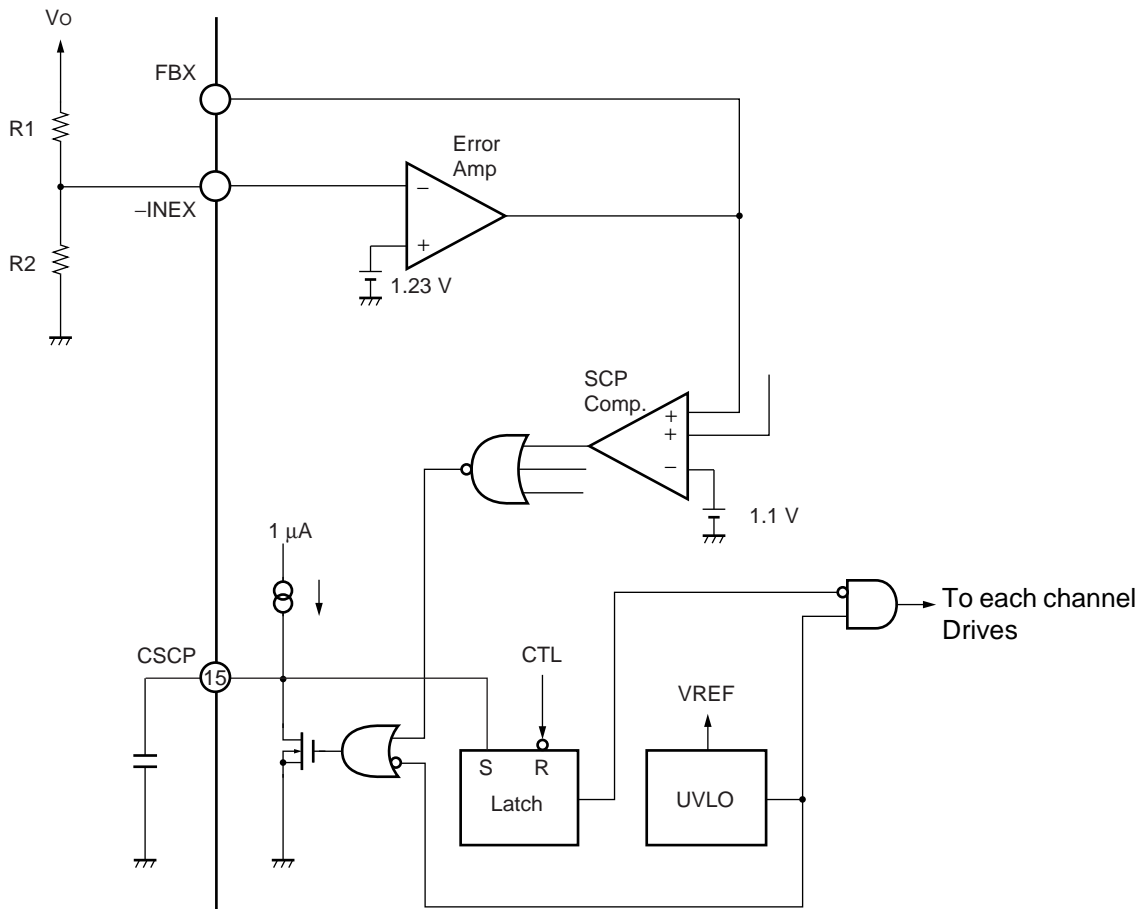

X: Each channel No.

■ TREATMENT WITHOUT USING CSCP TERMINAL

When not using the timer-latch short-circuit protection circuit, connect the CSCP terminal (pin 15) to GND with the shortest distance.

• Treatment without using CSCP terminal

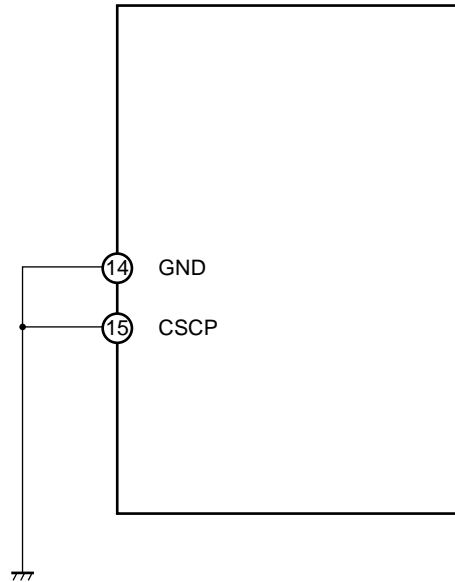

■ SETTING THE DEAD TIME

When the device is set for step-up or inverted output based on the step-up or step-up/down Zeta conversion, step-up/down Sepic conversion or flyback conversion, the FB terminal voltage may reach and exceed the triangular wave voltage due to load fluctuation. If this case happens, the output transistor is fixed to a full-ON state (ON duty = 100 %). To prevent this, set the maximum duty of the output transistor. To set it, set the voltage at the DTC terminal by applying a resistive voltage divider to the VREF voltage as shown below.

When the DTC terminal voltage is higher than the triangular wave voltage, the output transistor is turned on. The maximum duty calculation formula assuming that triangular wave amplitude $\hat{v} = 0.5 \text{ V}$ and triangular wave lower voltage $v_{\text{min}} = 0.4 \text{ V}$ is given below.

$$\text{DUTY (ON) Max} \hat{=} \frac{V_{\text{dt}} - 0.4 \text{ V}}{0.5 \text{ V}} \times 100 (\%), \quad V_{\text{dt}} = \frac{R_{\text{b}}}{R_{\text{a}} + R_{\text{b}}} \times V_{\text{REF}}$$

When the DTC terminal is not used, connect it directly to the VREF terminal (pin 11) as shown below (when no dead time is set).

• When using DTC to set dead time

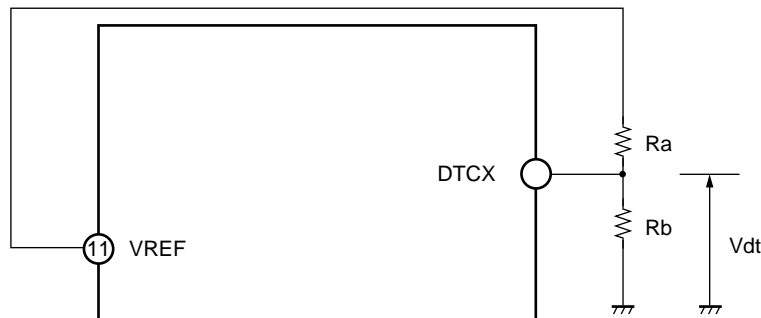

X: Each channel No.

• When no dead time is set

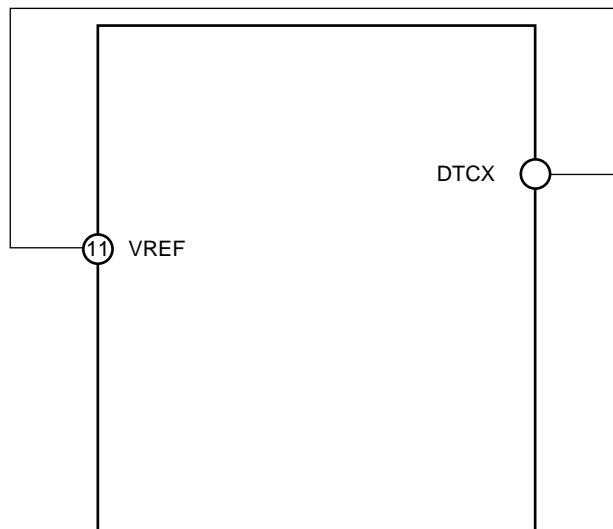

X: Each channel No.

I/O EQUIVALENT CIRCUIT

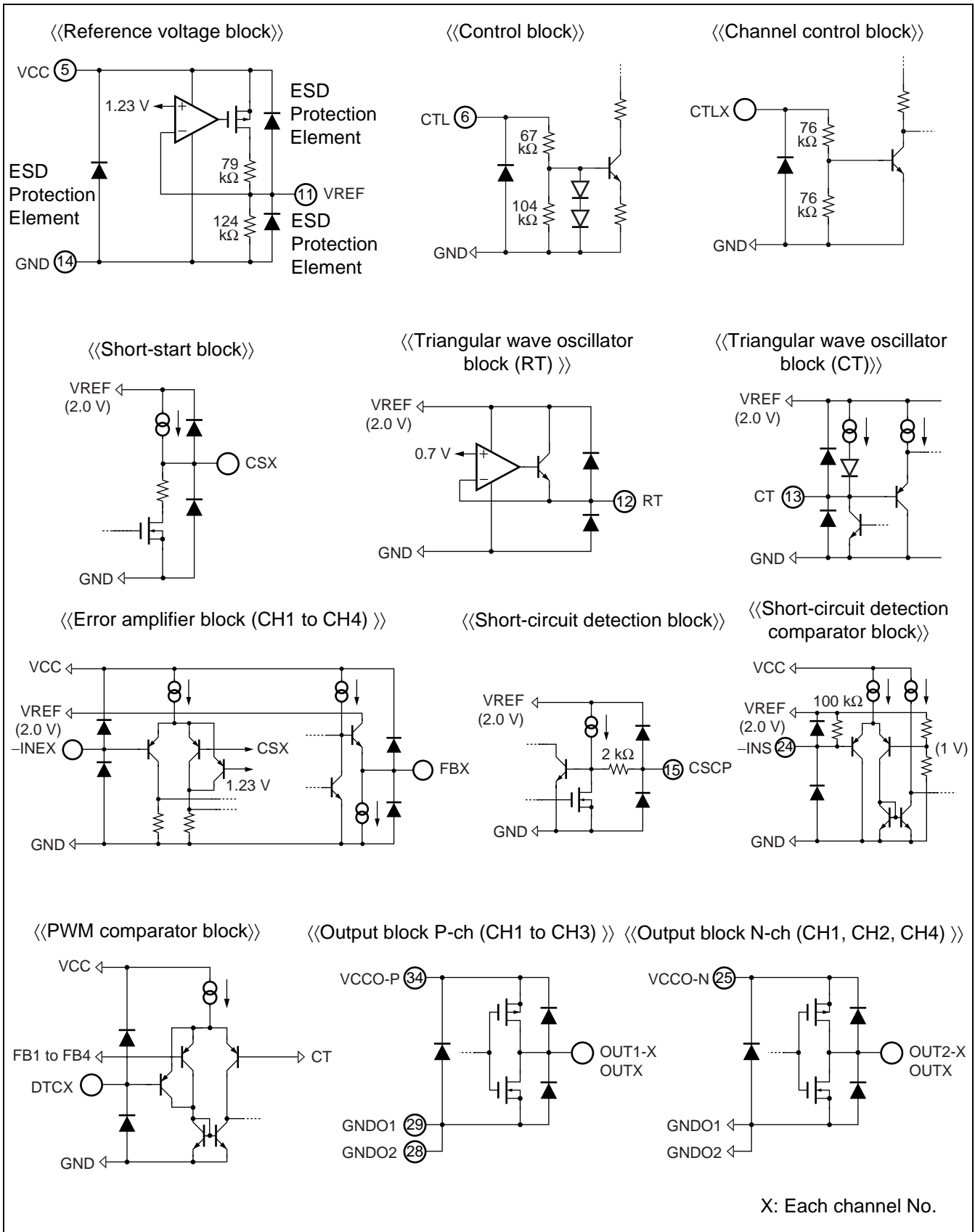

MB39A110

APPLICATION EXAMPLE

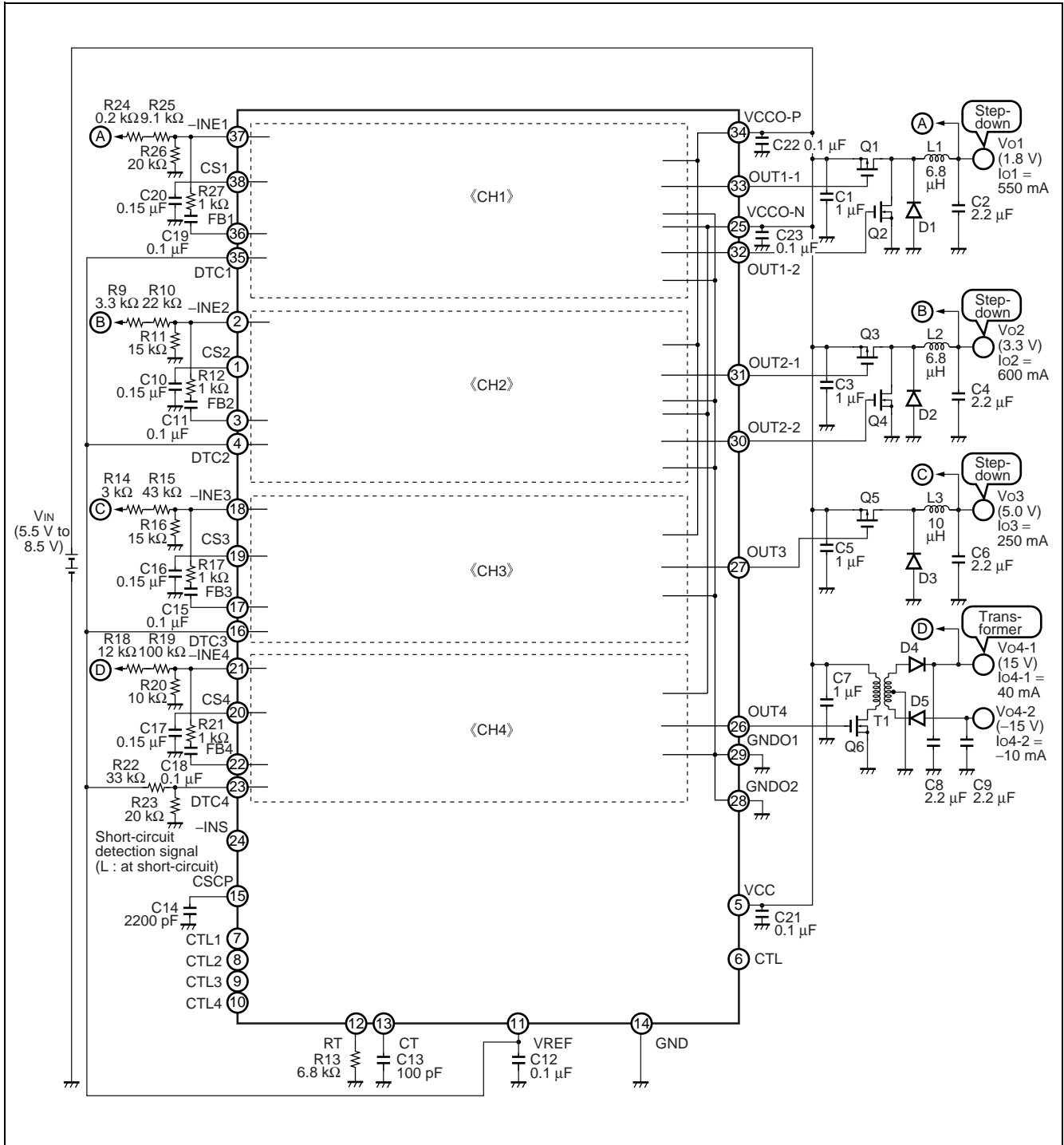

■ PARTS LIST

COMPONENT	ITEM	SPECIFICATION		VENDOR	PARTS No.
Q1, Q3, Q5 Q2, Q4 Q6	P-ch FET N-ch FET N-ch FET	VDS = -20 V, ID = -1.0 A VDS = 20 V, ID = 1.8 A VDS = 30 V, ID = 1.4 A		SANYO SANYO SANYO	MCH3307 MCH3405 MCH3408
D1 to D3 D4, D5	Diode Diode	VF = 0.4 V (Max) , IF = 1 A VF = 0.55 V (Max) , IF = 0.5 A		SANYO SANYO	SBS004 SB05-05CP
L1, L2 L3	Inductor Inductor	6.8 μ H 10 μ H	1.1 A, 47 m Ω 0.94 A, 56 m Ω	TDK TDK	RLF5018T- 6R8M1R1 RLF5018T- 100MR94
T1	Transformer	—	—	SUMIDA	CLQ52 5388-T139
C1, C3, C5, C7 C2, C4, C6, C8 C9, C11 C10, C16, C17 C11, C12, C15 C13 C14 C18, C19 C20 C21 to C23	Ceramics Condenser Ceramics Condenser Ceramics Condenser Ceramics Condenser Ceramics Condenser Ceramics Condenser Ceramics Condenser Ceramics Condenser Ceramics Condenser Ceramics Condenser Ceramics Condenser	1 μ F 2.2 μ F 2.2 μ F 0.15 μ F 0.1 μ F 100 pF 2200 pF 0.1 μ F 0.15 μ F 0.1 μ F	25 V 25 V 25 V 16 V 50 V 50 V 50 V 50 V 50 V 16 V 50 V	TDK TDK TDK TDK TDK TDK TDK TDK TDK TDK TDK	C3216JB1E105K C3216JB1E225K C3216JB1E225K C1608JB1C154M C1608JB1H104K C1608CH1H101J C1608JB1H222K C1608JB1H104K C1608JB1C154M C1608JB1H104K
R9 R10 R11, R16 R12, R17, R21 R13 R14 R15 R18 R19 R20 R22 R23, R26 R24 R25 R27	Resistor Resistor Resistor Resistor Resistor Resistor Resistor Resistor Resistor Resistor Resistor Resistor Resistor Resistor Resistor Resistor Resistor	3.3 k Ω 22 k Ω 15 k Ω 1 k Ω 6.8 k Ω 3 k Ω 43 k Ω 12 k Ω 100 k Ω 10 k Ω 33 k Ω 20 k Ω 200 Ω 9.1 k Ω 1 k Ω	0.5% 0.5% 0.5% 0.5% 0.5% 0.5% 0.5% 0.5% 0.5% 0.5% 0.5% 0.5% 0.5% 0.5% 0.5% 0.5%	ssm ssm ssm ssm ssm ssm ssm ssm ssm ssm ssm ssm ssm ssm ssm ssm	RR0816P-332-D RR0816P-223-D RR0816P-153-D RR0816P-102-D RR0816P-682-D RR0816P-302-D RR0816P-433-D RR0816P-123-D RR0816P-104-D RR0816P-103-D RR0816P-333-D RR0816P-203-D RR0816P-201-D RR0816P-912-D RR0816P-102-D

Note : SANYO : SANYO Electric Co., Ltd.
 TDK : TDK Corporation
 SUMIDA : SUMIDA Electric Co., Ltd.
 ssm : SUSUMU Co., Ltd.

■ REFERENCE DATA

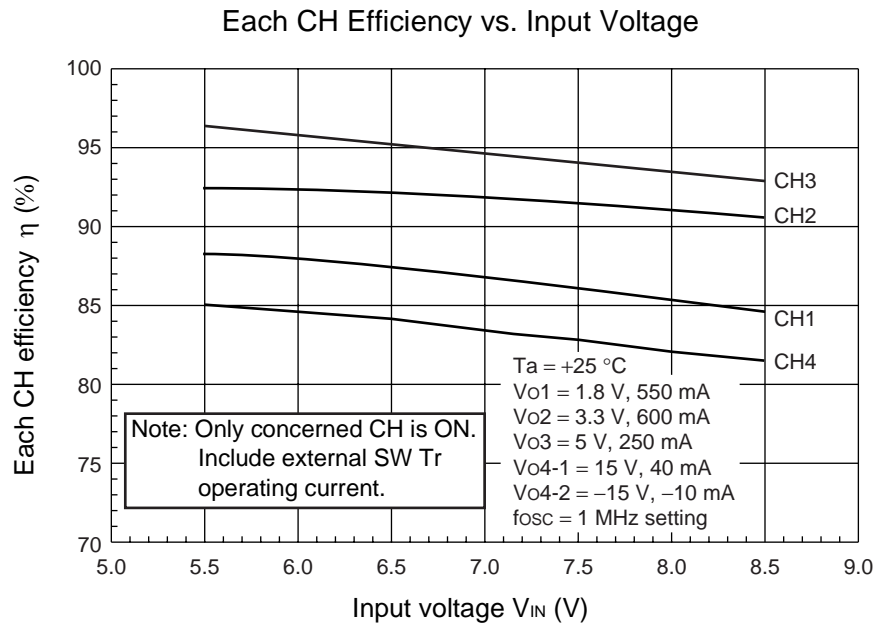
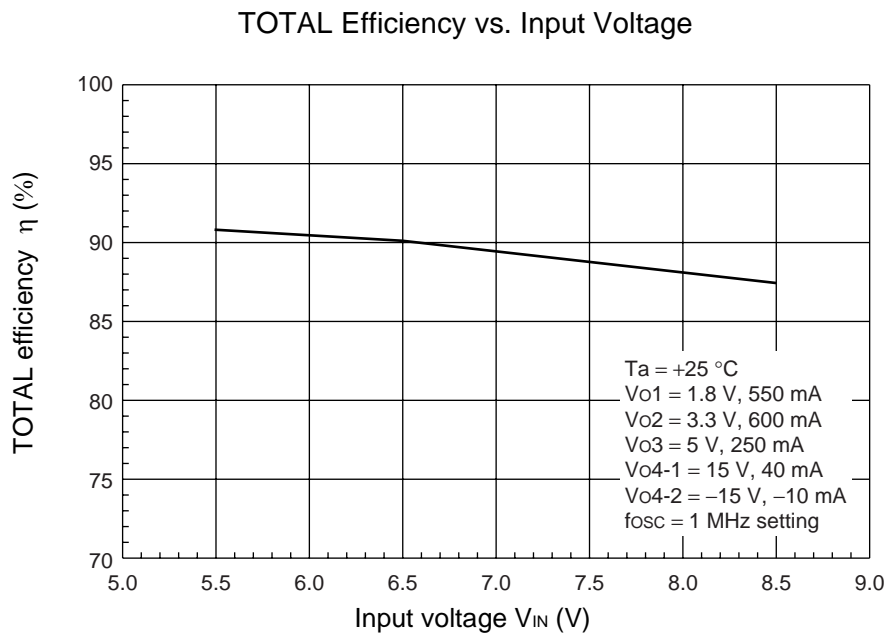

(Continued)

Conversion Efficiency vs. Load Current (CH1, CH2, CH3)

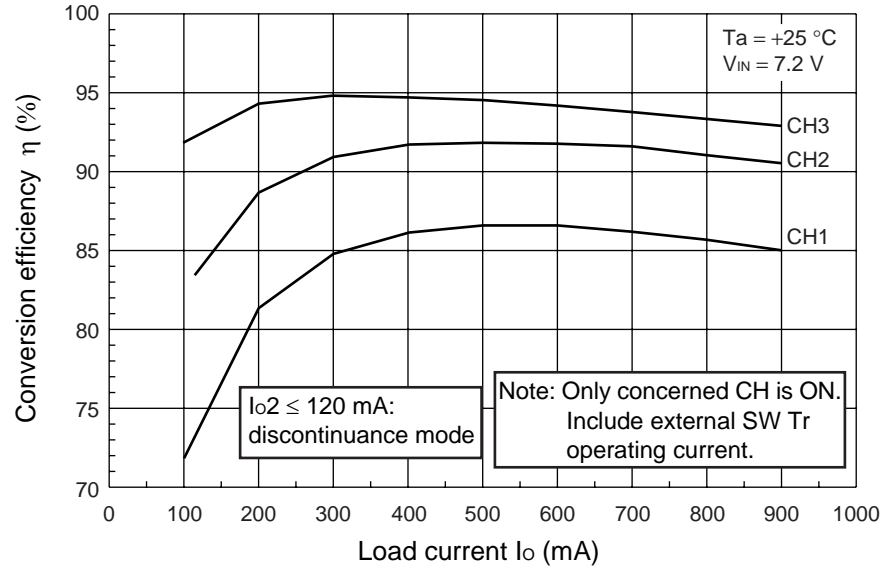

Conversion Efficiency vs. Load Current (CH4)

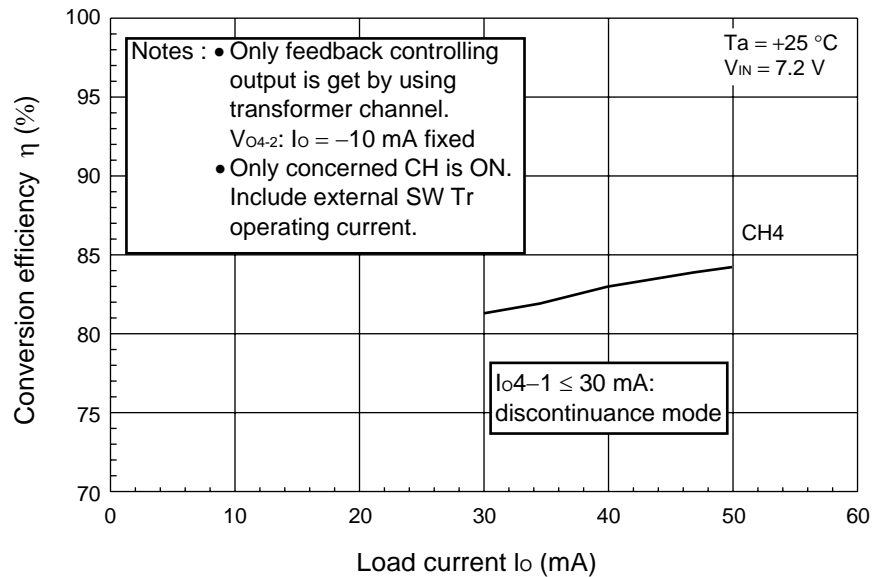

(Continued)

Switching Wave Form

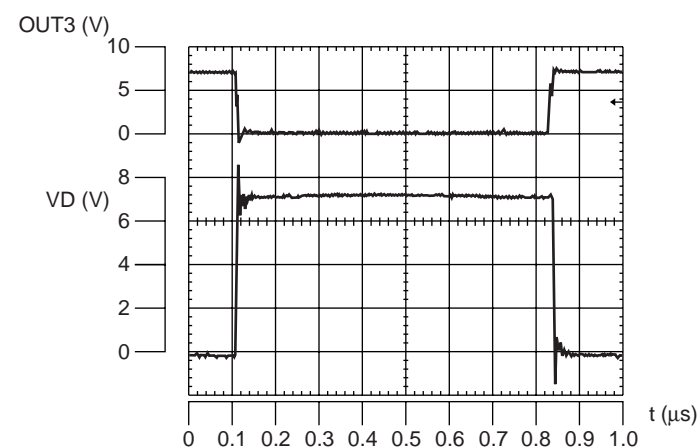
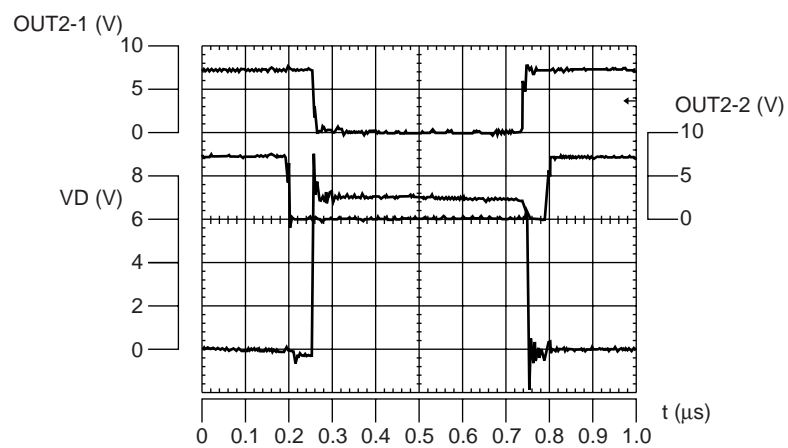
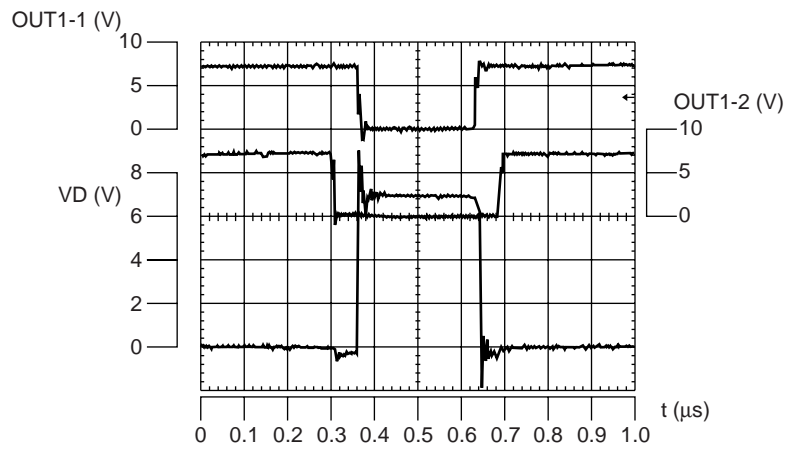

(Continued)

(Continued)

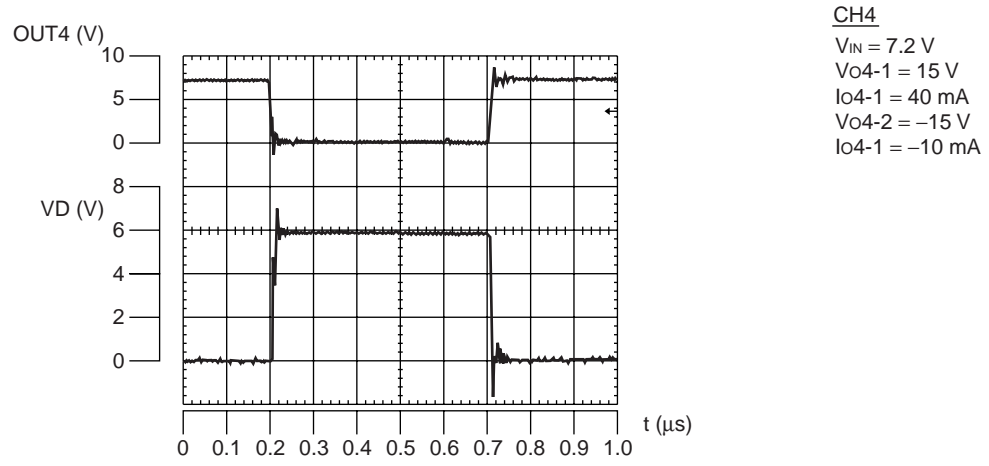

MB39A110

■ USAGE PRECAUTIONS

- Printed circuit board ground lines should be set up with consideration for common impedance.
- Take appropriate static electricity measures.
 - Containers for semiconductor materials should have anti-static protection or be made of conductive material.
 - After mounting, printed circuit boards should be stored and shipped in conductive bags or containers.
 - Work platforms, tools, and instruments should be properly grounded.
 - Working personnel should be grounded with resistance of 250 kΩ to 1 MΩ between body and ground.
- Do not apply negative voltages.
 - The use of negative voltages below -0.3 V may create parasitic transistors on LSI lines, which can cause malfunction.

■ ORDERING INFORMATION

Part number	Package	Remarks
MB39A110PFT-□□□E1	38-pin plastic TSSOP (FPT-38P-M03)	Lead Free version

■ EV BOARD ORDERING INFORMATION

EV board part No.	EV board version No.	Remarks
MB39A110EVB	Board Rev. 1.0	TSSOP-38P

■ RoHS COMPLIANCE INFORMATION OF LEAD (Pb) FREE VERSION

The LSI products of Fujitsu Microelectronics with “E1” are compliant with RoHS Directive , and has observed the standard of lead, cadmium, mercury, Hexavalent chromium, polybrominated biphenyls (PBB) , and polybrominated diphenyl ethers (PBDE) .

The product that conforms to this standard is added “E1” at the end of the part number.

■ MARKING FORMAT (LEAD FREE VERSION)

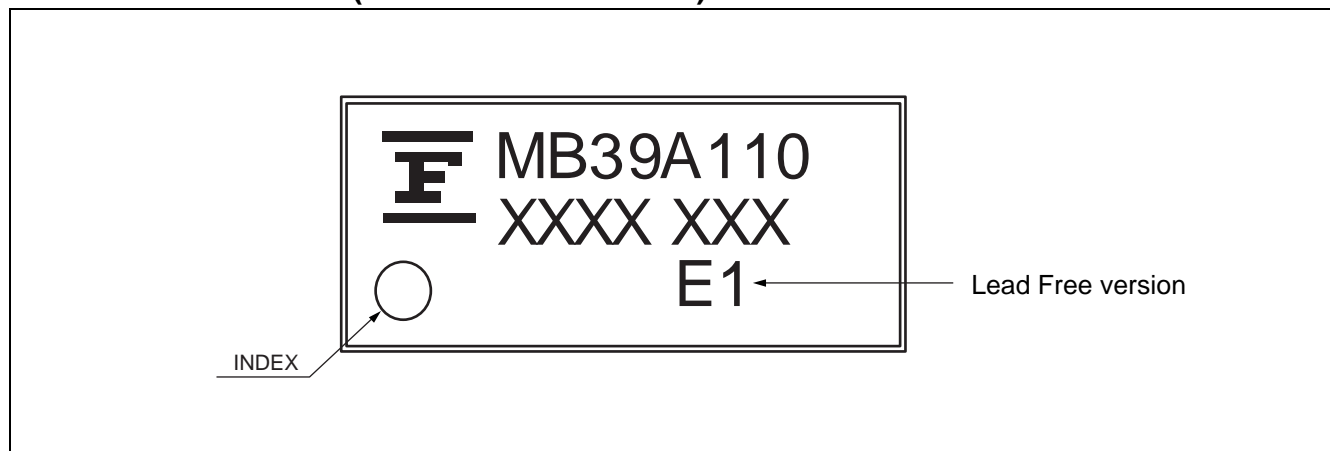

■ LABELING SAMPLE (LEAD FREE VERSION)

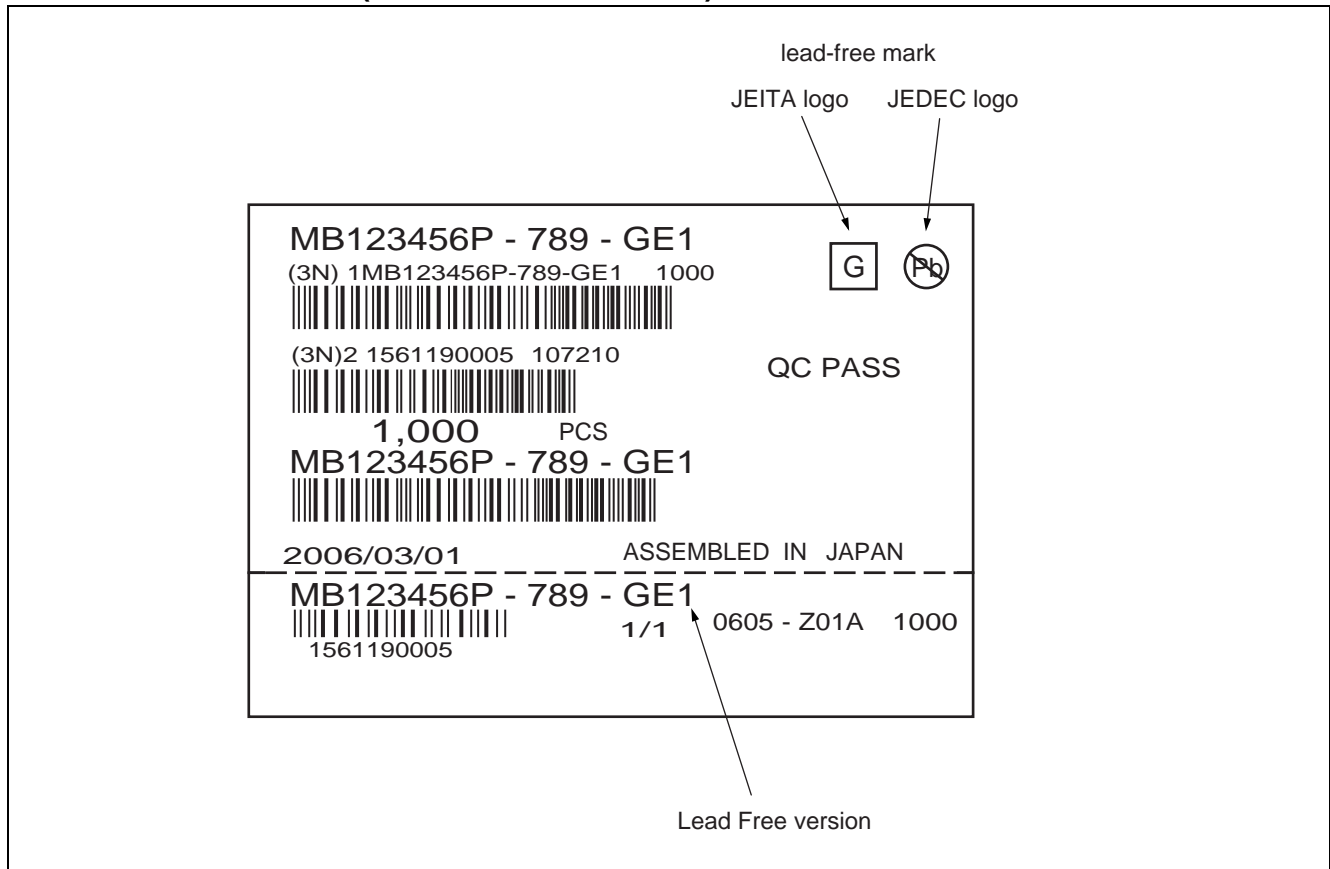

■ PACKAGE DIMENSION

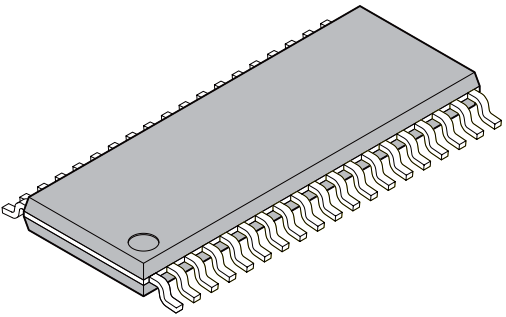
<p>38-pin plastic TSSOP</p>  <p>(FPT-38P-M03)</p>	Lead pitch	0.50 mm	
	Package width × package length	4.40 × 9.70 mm	
	Lead shape	Gullwing	
	Sealing method	Plastic mold	
	Mounting height	1.10 mm MAX	

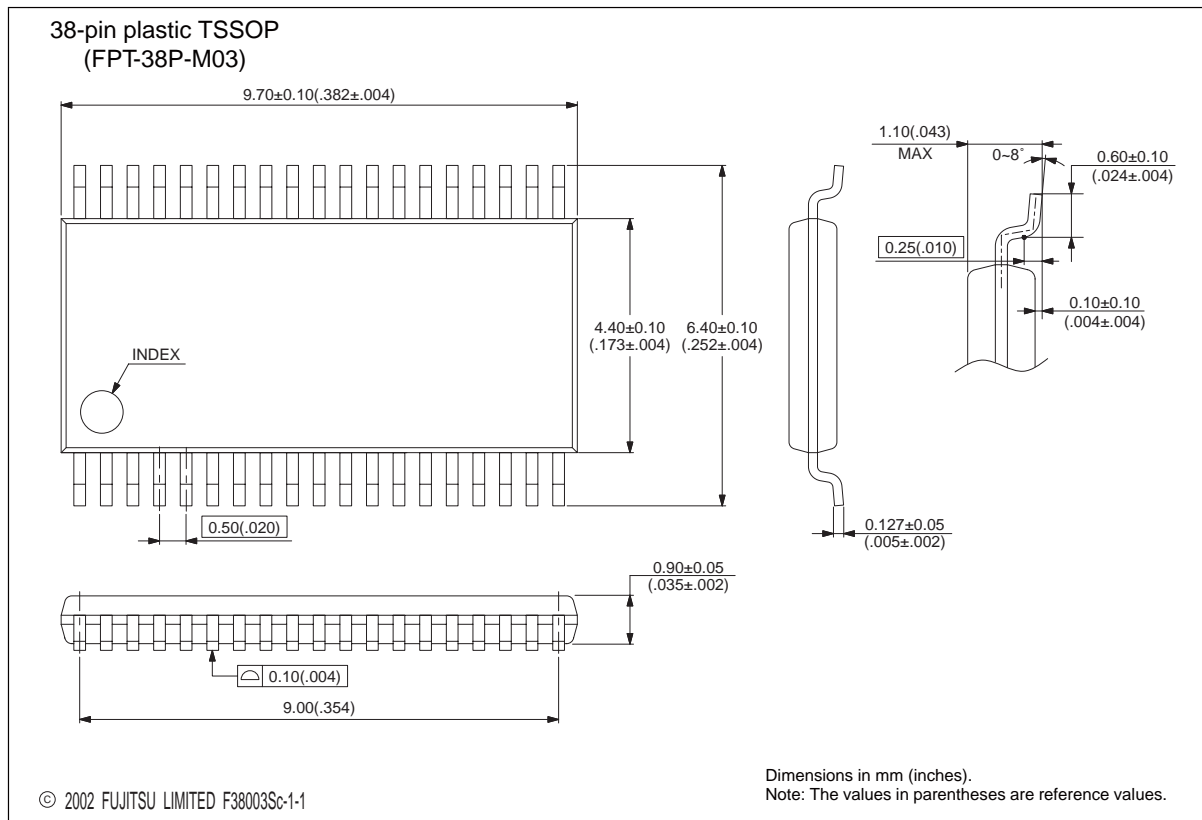

FUJITSU MICROELECTRONICS LIMITED

Shinjuku Dai-Ichi Seimei Bldg. 7-1, Nishishinjuku 2-chome, Shinjuku-ku,
Tokyo 163-0722, Japan Tel: +81-3-5322-3347 Fax: +81-3-5322-3387
<http://jp.fujitsu.com/fml/en/>

For further information please contact:

North and South America

FUJITSU MICROELECTRONICS AMERICA, INC.
1250 E. Arques Avenue, M/S 333
Sunnyvale, CA 94085-5401, U.S.A.
Tel: +1-408-737-5600 Fax: +1-408-737-5999
<http://www.fma.fujitsu.com/>

Europe

FUJITSU MICROELECTRONICS EUROPE GmbH
Pittlerstrasse 47, 63225 Langen,
Germany
Tel: +49-6103-690-0 Fax: +49-6103-690-122
<http://emea.fujitsu.com/microelectronics/>

Korea

FUJITSU MICROELECTRONICS KOREA LTD.
206 KOSMO TOWER, 1002 Daechi-Dong,
Kangnam-Gu, Seoul 135-280
Korea
Tel: +82-2-3484-7100 Fax: +82-2-3484-7111
<http://www.fmk.fujitsu.com/>

Asia Pacific

FUJITSU MICROELECTRONICS ASIA PTE LTD.
151 Lorong Chuan, #05-08 New Tech Park,
Singapore 556741
Tel: +65-6281-0770 Fax: +65-6281-0220
<http://www.fujitsu.com/sg/services/micro/semiconductor/>

FUJITSU MICROELECTRONICS SHANGHAI CO., LTD.
Rm.3102, Bund Center, No.222 Yan An Road(E),
Shanghai 200002, China
Tel: +86-21-6335-1560 Fax: +86-21-6335-1605
<http://cn.fujitsu.com/fmc/>

FUJITSU MICROELECTRONICS PACIFIC ASIA LTD.
10/F., World Commerce Centre, 11 Canton Road
Tsimshatsui, Kowloon
Hong Kong
Tel: +852-2377-0226 Fax: +852-2376-3269
<http://cn.fujitsu.com/fmc/tw>

All Rights Reserved.

The contents of this document are subject to change without notice.

Customers are advised to consult with sales representatives before ordering.

The information, such as descriptions of function and application circuit examples, in this document are presented solely for the purpose of reference to show examples of operations and uses of FUJITSU MICROELECTRONICS device; FUJITSU MICROELECTRONICS does not warrant proper operation of the device with respect to use based on such information. When you develop equipment incorporating the device based on such information, you must assume any responsibility arising out of such use of the information.

FUJITSU MICROELECTRONICS assumes no liability for any damages whatsoever arising out of the use of the information.

Any information in this document, including descriptions of function and schematic diagrams, shall not be construed as license of the use or exercise of any intellectual property right, such as patent right or copyright, or any other right of FUJITSU MICROELECTRONICS or any third party or does FUJITSU MICROELECTRONICS warrant non-infringement of any third-party's intellectual property right or other right by using such information. FUJITSU MICROELECTRONICS assumes no liability for any infringement of the intellectual property rights or other rights of third parties which would result from the use of information contained herein.

The products described in this document are designed, developed and manufactured as contemplated for general use, including without limitation, ordinary industrial use, general office use, personal use, and household use, but are not designed, developed and manufactured as contemplated (1) for use accompanying fatal risks or dangers that, unless extremely high safety is secured, could have a serious effect to the public, and could lead directly to death, personal injury, severe physical damage or other loss (i.e., nuclear reaction control in nuclear facility, aircraft flight control, air traffic control, mass transport control, medical life support system, missile launch control in weapon system), or (2) for use requiring extremely high reliability (i.e., submersible repeater and artificial satellite).

Please note that FUJITSU MICROELECTRONICS will not be liable against you and/or any third party for any claims or damages arising in connection with above-mentioned uses of the products.

Any semiconductor devices have an inherent chance of failure. You must protect against injury, damage or loss from such failures by incorporating safety design measures into your facility and equipment such as redundancy, fire protection, and prevention of over-current levels and other abnormal operating conditions.

Exportation/release of any products described in this document may require necessary procedures in accordance with the regulations of the Foreign Exchange and Foreign Trade Control Law of Japan and/or US export control laws.

The company names and brand names herein are the trademarks or registered trademarks of their respective owners.