

ASSP For Power Supply Applications (General Purpose DC/DC Converter)

2-Channel DC/DC Converter IC with Overcurrent Protection Symmetrical-Phase Type

MB39A106

■ DESCRIPTION

The MB39A106 is a symmetrical-phase type of two-channel, DC/DC converter IC using pulse width modulation (PWM), incorporating an overcurrent protection circuit (requiring no current sense resistor) and an overvoltage protection circuit. Providing high output driving capabilities, the MB39A106 is suitable for down-conversion.

The MB39A106 adopts both synchronous rectification to provide high efficiency and symmetrical phasing (two anti-phase triangular waves) which contributes to making the input capacitor small.

The MB39A106 contains a Bootstrap diode resulting in a reduced number of components used. It also contains a variety of protection features which output the protection status upon detection of an overvoltage or overcurrent while reducing the number of external protective devices required.

The result is an ideal built-in power supply for driving products with high speed CPU's such as home TV game devices and notebook PC's.

■ FEATURES

- Built-in bootstrap diode
- Built-in timer-latch overcurrent protection circuit (requiring no current sense resistor)
- Built-in timer-latch overvoltage protection circuit
- Synchronous rectification system providing high efficiency
- Power supply voltage range: 6.5 V to 18 V
- PWRGOOD terminals (open-drain) to output the protection status
- Symmetrical-phase system reducing the input capacitor loss
- Built-in channel control function
- One type of package (TSSOP-30pin : 1 type)
- Reference voltage: 3.5 V \pm 1 %
- Error amplifier threshold voltage: 1.23 V \pm 1 % (Ta = 0 °C to + 85 °C)
- Support for frequency setting using an external resistor (Frequency setting capacitor integrated)
- Oscillation frequency range: 100 kHz to 500 kHz
- Standby current : 0 μ A (Typ)
- Built-in circuit for load-independent soft-start and discharge control
- Built-in totem-pole output for N-ch MOS FET
- One type of package (TSSOP-30 pin : 1 type)

■ APPLICATION

- Home Video Game
- IP phone
- Printer etc.

MB39A106

■ PIN ASSIGNMENT

(TOP VIEW)

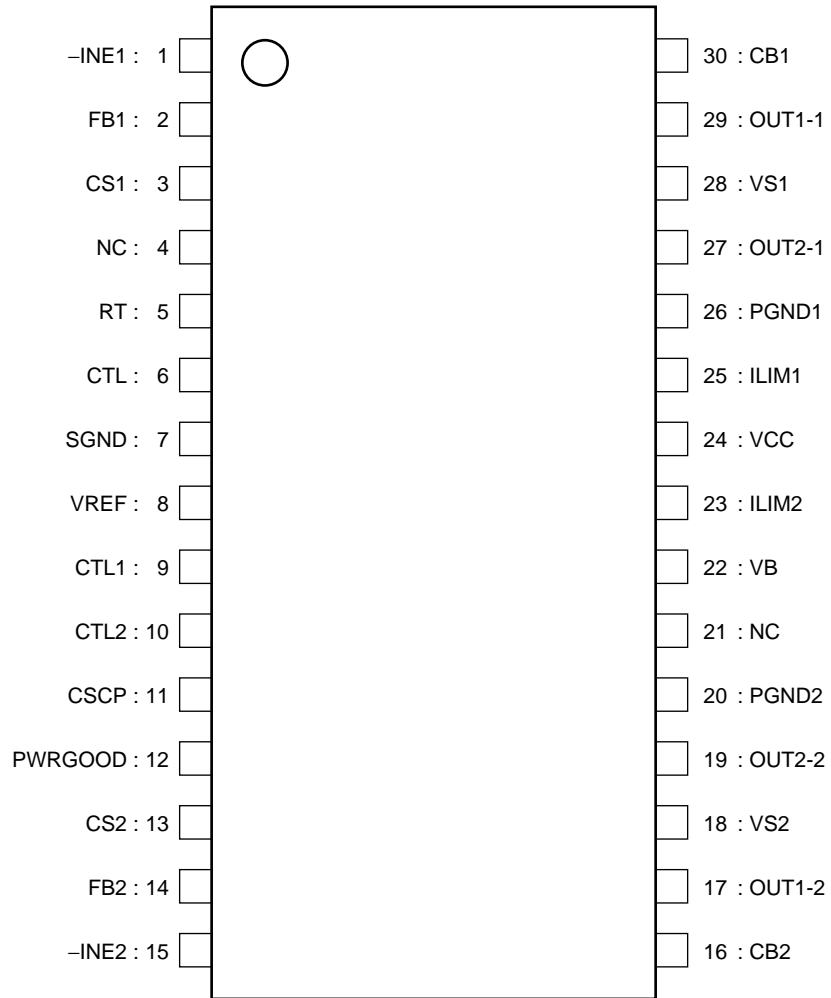

(FPT-30P-M04)

■ PIN DESCRIPTION

Pin No.	Symbol	I/O	Descriptions
1	-INE1	I	CH1 error amp inverted input terminal
2	FB1	O	CH1 error amp output terminal
3	CS1	—	CH1 soft-start capacitor connection terminal
4	NC	—	No connection
5	RT	—	Triangular waveform oscillation frequency setting resistor connection terminal
6	CTL	I	Power supply control terminal “H” level : IC operating mode “L” level : IC Standby mode
7	SGND	—	Ground terminal
8	VREF	O	Reference voltage output terminal
9	CTL1	I	CH1 control terminal “H” level : CH1 ON state “L” level : CH1 OFF state and protection status reset
10	CTL2	I	CH2 control terminal “H” level : CH2 ON state “L” level : CH2 OFF state and protection status reset
11	CSCP	—	Timer-latch short-circuit protection capacitor connection terminal
12	PWRGOOD	O	CH1, CH2 protection status output terminal
13	CS2	—	CH2 soft-start capacitor connection terminal
14	FB2	O	CH2 error amp output terminal
15	-INE2	I	CH2 error amp inverted input terminal
16	CB2	—	CH2 boot capacitor connection terminal Connect a capacitor between the CB2 and VS2 terminals.
17	OUT1-2	O	CH2 totem-pole output terminal (External main-side FET gate drive)
18	VS2	—	CH2 external main-side FET source connection terminal
19	OUT2-2	O	CH2 totem-pole output terminal (External synchronous-rectification-side FET gate drive)
20	PGND2	—	Ground terminal
21	NC	—	No connection
22	VB	O	Output circuit bias output terminal
23	ILIM2	I	CH2 overcurrent detection resistor connection terminal
24	VCC	—	Reference voltage, control circuit power supply terminal
25	ILIM1	I	CH1 overcurrent detection resistor connection terminal
26	PGND1	—	Ground terminal
27	OUT2-1	O	CH1 totem-pole output terminal (External synchronous-rectification-side FET gate drive)
28	VS1	—	CH1 external main-side FET source connection terminal
29	OUT1-1	O	CH1 totem-pole output terminal (External main-side FET gate drive)
30	CB1	—	CH1 boot capacitor connection terminal Connect a capacitor between the CB1 and VS1 terminals.

MB39A106

■ BLOCK DIAGRAM

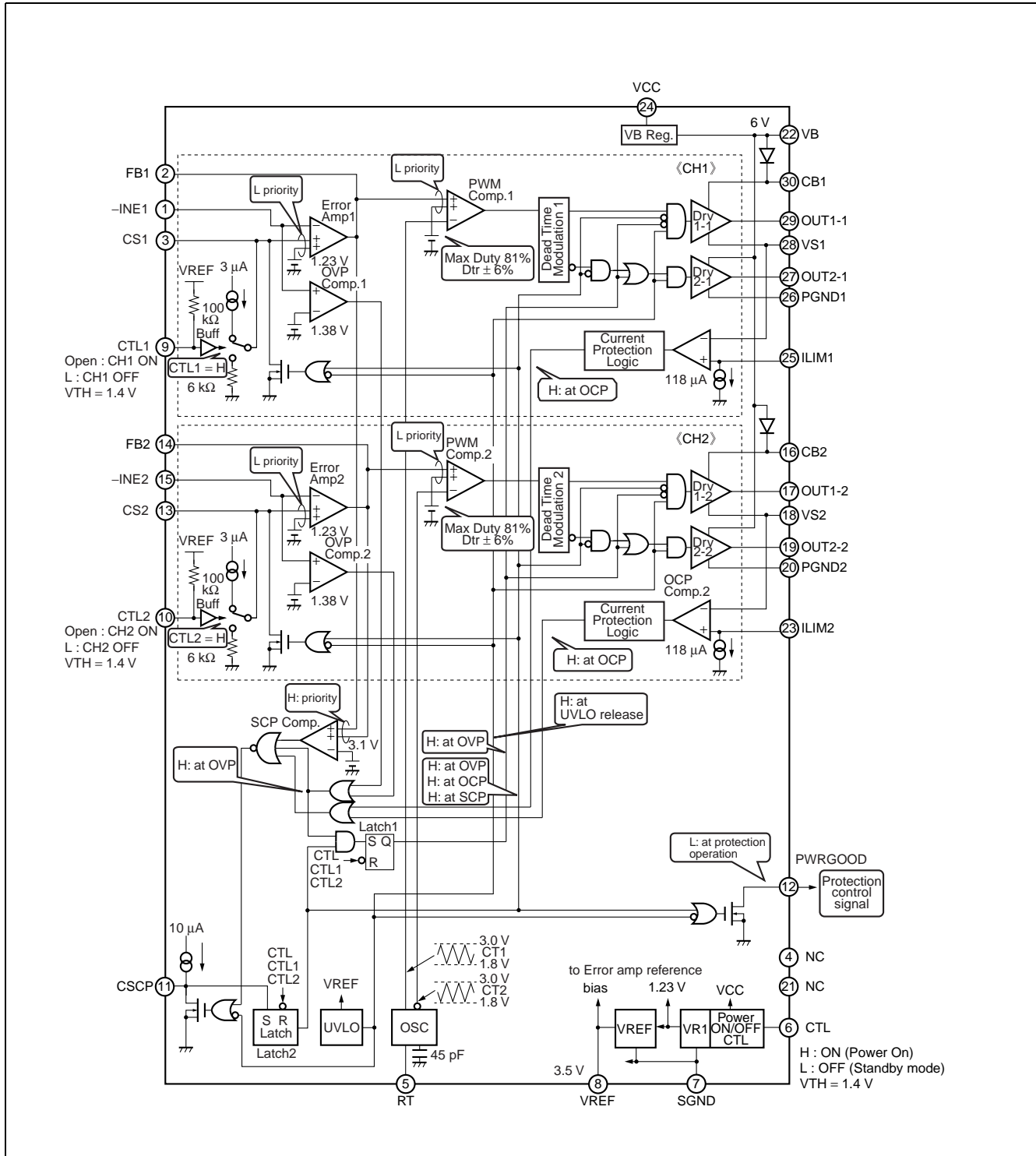

■ ABSOLUTE MAXIMUM RATINGS

Parameter	Symbol	Condition	Rating		Unit
			Min	Max	
Power-supply voltage	V_{CC}	—	—	20	V
Boot voltage	V_{CB}	CB terminal	—	25	V
Output current	I_o	—	—	120	mA
Peak output current	I_{OP}	Duty $\leq 5\%$ ($t = 1 / f_{osc} \times \text{Duty}$)	—	800	mA
Power dissipation	P_D	$T_a \leq +25\text{ }^\circ\text{C}$	—	1390*	mW
Storage temperature	T_{STG}	—	-55	+125	$^\circ\text{C}$

* : The packages are mounted on the dual-sided epoxy board (10 cm × 10 cm) .

WARNING: Semiconductor devices can be permanently damaged by application of stress (voltage, current, temperature, etc.) in excess of absolute maximum ratings. Do not exceed these ratings.

MB39A106

■ RECOMMENDED OPERATING CONDITIONS

Parameter	Symbol	Condition	Value			Unit
			Min	Typ	Max	
Power-supply voltage	V _{CC}	—	6.5	12	18	V
Boot voltage	V _{CB}	CB terminal	—	—	24	V
Reference voltage output current	I _{OR}	VREF terminal	-1	—	0	mA
Bias output current	I _{OB}	VB terminal	-1	—	0	mA
Input voltage	V _{IN}	-INE terminal	0	—	V _{CC} - 1.8	V
	V _{CTL}	CTL1, CTL2 terminal	0	—	V _{REF}	V
		CTL terminal	0	—	V _{CC}	V
Output voltage	V _{PG}	PWRGOOD terminal	0	—	15	V
Output current	I _O	—	-100	—	+100	mA
Peak output current	I _{OP}	Duty ≤ 5% (t = 1 / f _{OSC} × Duty)	-700	—	+700	mA
Oscillation frequency	f _{OSC}	—	100	300	500	kHz
Timing resistor	R _T	—	30	47	130	kΩ
Boot capacitor	C _B	—	—	0.1	1.0	μF
Reference voltage output capacitor	C _{REF}	VREF terminal	—	0.1	1.0	μF
Bias output capacitor	C _{VB}	VB terminal	1.0	4.7	10	μF
Soft-start capacitor	C _S	—	—	0.1	1	μF
Short-circuit detection capacitor	C _{SCP}	—	—	0.01	1	μF
Overcurrent detection setting resistor	R _{LIM}	—	0.1	1	10	kΩ
Operating ambient temperature	T _a	—	-30	+25	+85	°C

WARNING: The recommended operating conditions are required in order to ensure the normal operation of the semiconductor device. All of the device's electrical characteristics are warranted when the device is operated within these ranges.

Always use semiconductor devices within their recommended operating condition ranges. Operation outside these ranges may adversely affect reliability and could result in device failure.

No warranty is made with respect to uses, operating conditions, or combinations not represented on the data sheet. Users considering application outside the listed conditions are advised to contact their representatives beforehand.

■ ELECTRICAL CHARACTERISTICS

(VCC = 12 V, VB = 0 mA, VREF = 0 mA, Ta = +25 °C)

Parameter	Symbol	Pin No.	Conditions	Value			Unit	
				Min	Typ	Max		
Reference Voltage Block [REF]	Output voltage	VREF	8	Ta = +25 °C	3.465	3.500	3.535	V
		$\frac{\Delta V_{REF}}{V_{REF}}$	8	Ta = 0 °C to +85 °C	—	0.5*	—	%
	Input stability	Line	8	VCC = 6.5 V to 18 V	—	1	10	mV
	Load stability	Load	8	VREF = 0 mA to -1 mA	—	3	10	mV
	Short-circuit output current	Ios	8	VREF = 0 V	-40	-20	-10	mA
Bias Voltage Block [VB]	Output voltage	VB	22	—	5.88	6.00	6.12	V
Triangular Waveform Oscillator Block [OSC]	Oscillation frequency	fosc	17, 29	R _T = 47 kΩ	270	300	330	kHz
	Frequency/temperature variation	$\frac{\Delta f_{osc}}{f_{osc}}$	17, 29	Ta = 0 °C to +85 °C	—	1*	—	%
Undervoltage (VCC) Lockout Circuit Block [UVLO]	Threshold voltage	V _{TH}	8	VREF = $\underline{\uparrow}$	2.6	2.8	3.0	V
	Hysteresis width	V _H	8	—	—	0.2*	—	V
	Reset voltage	V _{RST}	8	VREF = $\underline{\downarrow}$	1.7	2.1	2.5	V
Short-circuit Protection Circuit Block [SCP]	Threshold voltage	V _{TH}	11	—	0.65	0.70	0.75	V
	Input source current	I _{CSCP}	11	—	-14	-10	-6	μA
Overcurrent Protection Circuit Block [OCP]	ILIM terminal input current	I _{LIM}	23, 25	R _T = 47 kΩ	106	118	130	μA
	Offset voltage	V _{IO}	23, 25	—	—	1*	—	mV
Overvoltage Protection Circuit Block [OVP]	Threshold voltage	V _{TH}	1, 15	-INE = $\underline{\uparrow}$	1.35	1.38	1.41	V
	Input bias current	I _B	1, 15	-INE = 0 V	-730	-110	—	nA
Protection Status Output Circuit Block [PWRGOOD]	Output leakage current	I _{LEAK}	12	PWRGOOD = 5 V	—	—	40	μA
	Output "L" level voltage	V _{OL}	12	PWRGOOD = 1 mA	—	0.1	0.4	V
Soft-start Circuit Block [CS]	Charge current	I _{CS}	3, 13	—	-4.2	-3.0	-1.8	μA

(Continued)

MB39A106

(VCC = 12 V, VB = 0 mA, VREF = 0 mA, Ta = +25 °C)

Parameter		Symbol	Pin No.	Conditions	Value			Unit
					Min	Typ	Max	
Error Amp Block [Error Amp]	Threshold voltage	V _{TH1}	1, 15	FB = 2.4 V, Ta = +25 °C	1.221	1.230	1.239	V
		V _{TH2}	1, 15	FB = 2.4 V, Ta = 0 °C to +85 °C	1.218	1.230	1.242	V
	Input bias current	I _B	1, 15	-INE = 0 V	-730	-110	—	nA
	Voltage gain	A _V	2, 14	DC	60	100	—	dB
	Frequency bandwidth	BW	2, 14	A _V = 0 dB	—	1.5*	—	MHz
	Output voltage	V _{FBH}	2, 14	—	3.2	3.4	—	V
		V _{FBL}	2, 14	—	—	40	200	mV
	Output source current	I _{SOURCE}	2, 14	FB = 2.4 V	—	-2	-1	mA
Output sink current	I _{SINK}	2, 14	FB = 2.4 V	150	250	—	μA	
PWM Comparator Block [PWM Comp.]	Threshold voltage	V _{TL}	2, 14	Duty cycle = 0 %	1.7	1.8	—	V
		V _{TH}	2, 14	Duty cycle = Dtr	—	2.86	3.00	V
Dead Time Control Block [DTC]	Maximum duty cycle	Dtr	17, 29	R _T = 47 kΩ	75	81	87	%
Output Block [Drive]	Output current (main side)	I _{SOURCE1}	17, 29	OUT1 = 12 V, CB = 17 V, VS = 12 V, Duty ≤ 5 % (t = 1/ fosc × Duty)	—	-700*	—	mA
		I _{SINK1}	17, 29	OUT1 = 17 V, CB = 17 V, VS = 12 V, Duty ≤ 5 % (t = 1/ fosc × Duty)	—	900*	—	mA
	Output voltage (main side)	V _{OH1}	17, 29	OUT1 = -100 mA, CB = 17 V, VS = 12 V	V _{CB} -2.5	V _{CB} -0.9	—	V
		V _{OL1}	17, 29	OUT1 = 100 mA, CB = 17 V, VS = 12 V	—	V _s +0.9	V _s +1.4	V
	Output current (synchronous rectification side)	I _{SOURCE2}	19, 27	OUT2 = 0 V, Duty ≤ 5 % (t = 1/ fosc × Duty)	—	-750*	—	mA
		I _{SINK2}	19, 27	OUT2 = 6 V, Duty ≤ 5 % (t = 1/ fosc × Duty)	—	900*	—	mA

(Continued)

(Continued)

(VCC = 12 V, VB = 0 mA, VREF = 0 mA, Ta = + 25 °C)

Parameter		Symbol	Pin No.	Conditions	Value			Unit
					Min	Typ	Max	
Output Block [Drive]	Output voltage (synchronous rectification side)	V _{OH2}	19, 27	OUT2 = - 100 mA	3.5	5.1	—	V
		V _{OL2}	19, 27	OUT2 = 100 mA	—	1.0	1.4	V
	Diode voltage	V _D	16, 30	VB = 10 mA	—	0.8	1.0	V
	Dead time	t _{D1}	29, 27, 17, 19	OUT1 = OUT2 = OPEN, VS = 0 V OUT2 : - OUT1 :	40	80	120	ns
t _{D2}		29, 27, 17, 19	OUT1 = OUT2 = OPEN, VS = 0 V OUT1 : - OUT2 :	60	120	180	ns	
Control Block [CTL, CTL1, CTL2]	Output ON condition	V _{ON}	9, 10	—	2	—	V _{REF}	V
	Output OFF condition	V _{OFF}	9, 10	—	0	—	0.8	V
	Output ON condition	V _{ON}	6	—	2	—	V _{CC}	V
	Output OFF condition	V _{OFF}	6	—	0	—	0.8	V
	Input current	I _{CTL}	9, 10	CTL1 = CTL2 = 0 V	- 44	- 35	- 29	μA
6			CTL = 5 V	—	50	75	μA	
General	Standby current	I _{CCS}	24	CTL = 0 V	—	0	10	μA
	Power-supply current	I _{CC}	24	CTL = 5 V	—	15	23	mA

*: Standard design value

TYPICAL CHARACTERISTICS

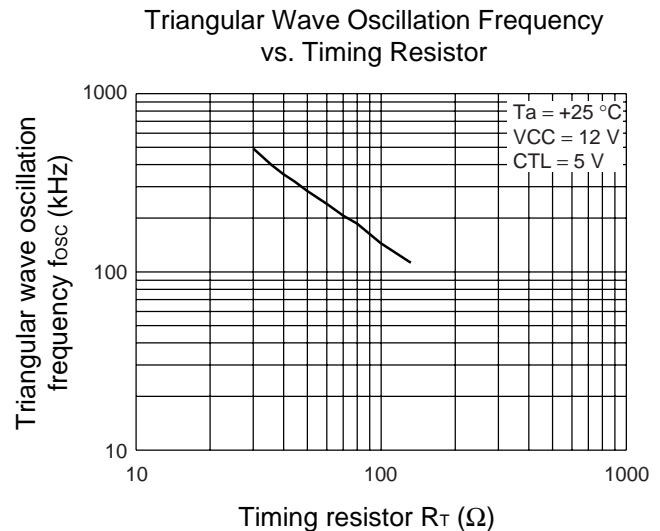
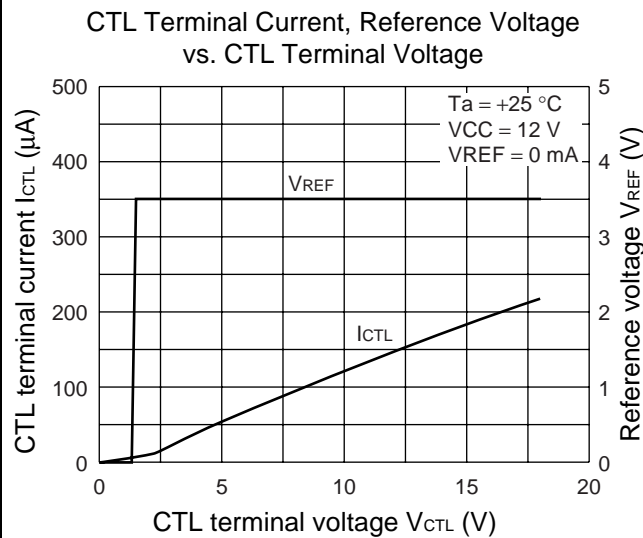
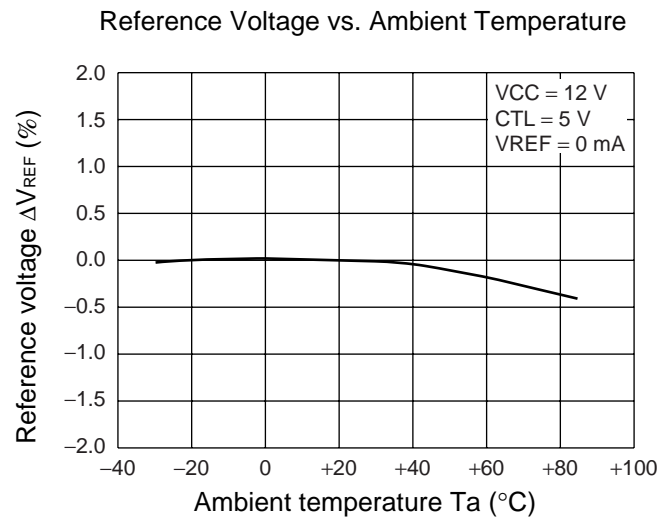
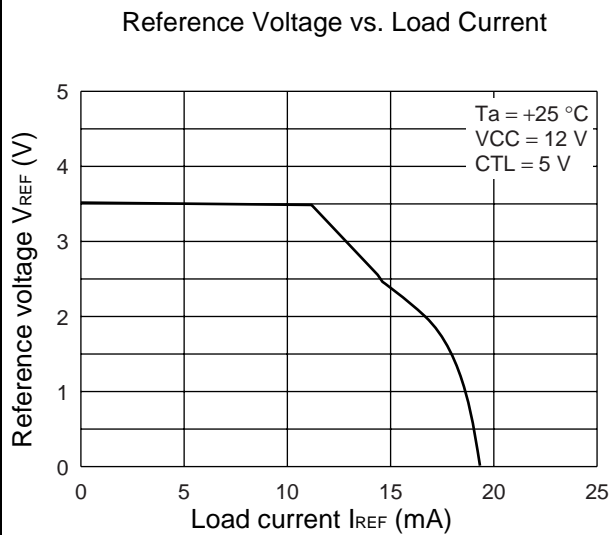
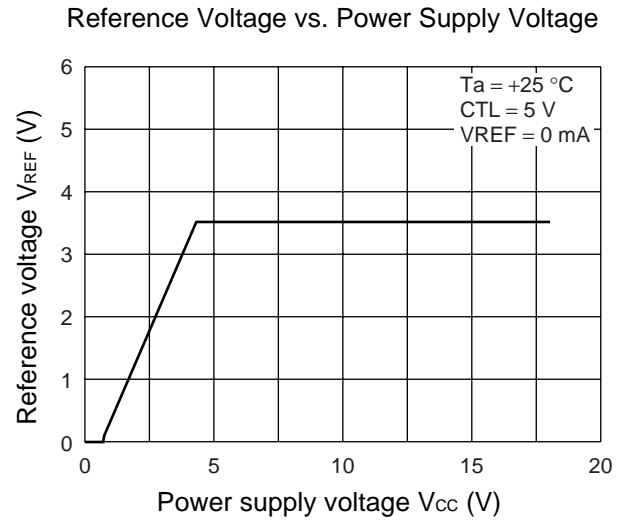
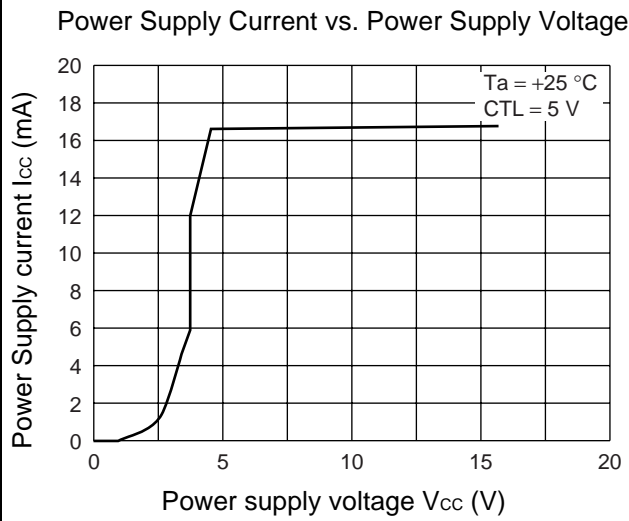

(Continued)

Triangular Wave Oscillation Frequency vs. Power Supply Voltage

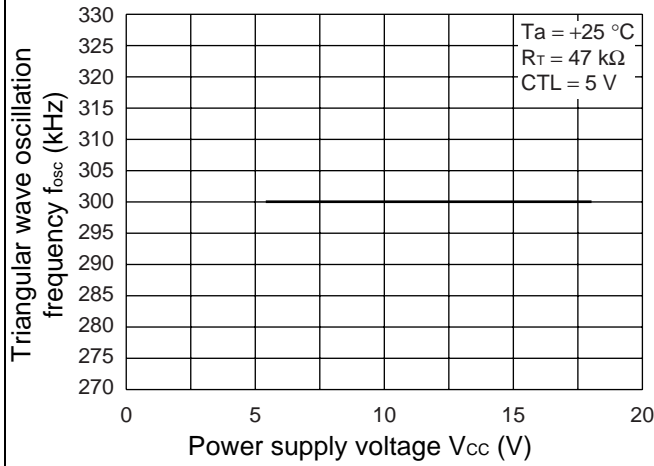

Triangular Wave Oscillation Frequency vs. Ambient Temperature

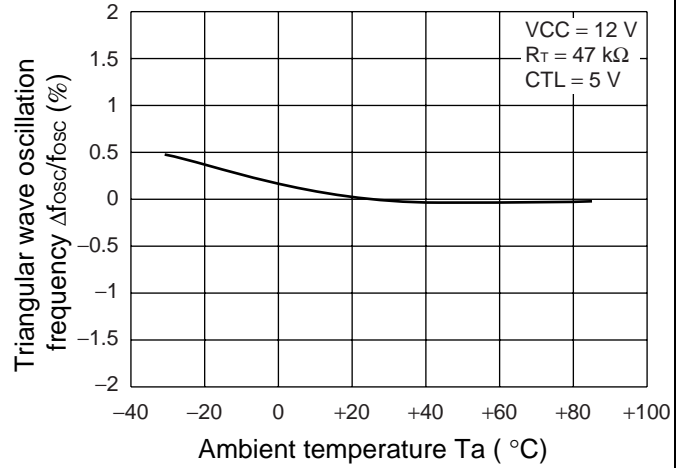

Error Amplifier Threshold Voltage vs. Ambient Temperature

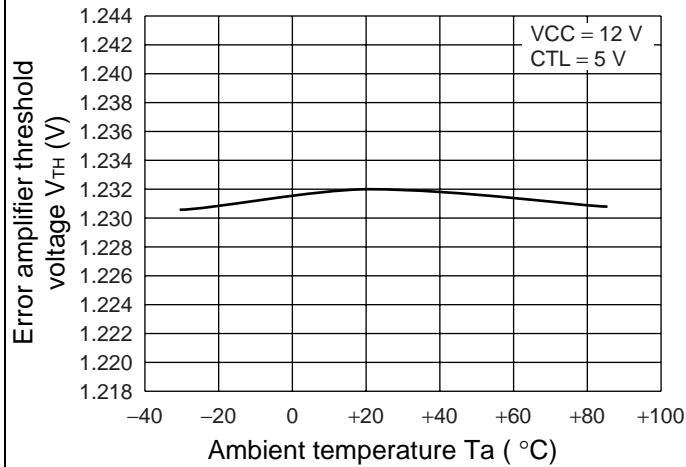

Error Amplifier, Gain, Phase vs. Frequency

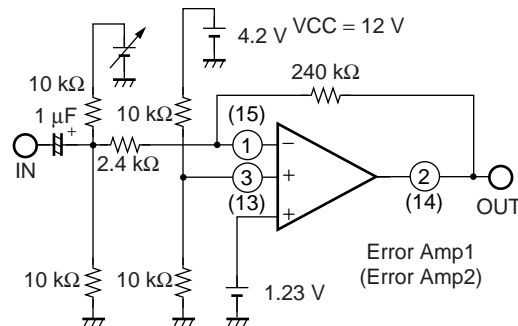
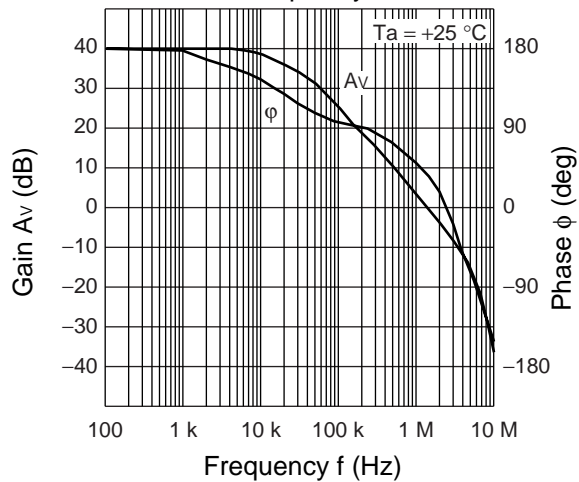

(Continued)

(Continued)

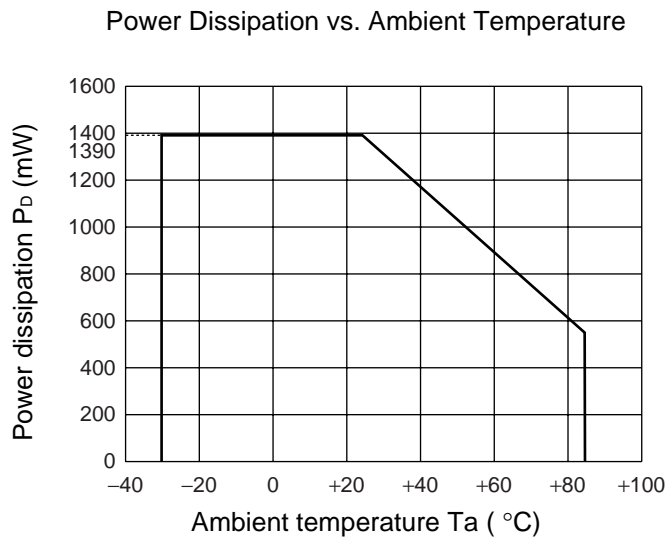

■ FUNCTIONS

1. DC/DC Converter Functions

(1) Reference voltage block (Ref)

The reference voltage circuit generates a temperature-compensated reference voltage (typically 3.5 V) using the voltage supplied from the power supply terminal (pin 24) . The voltage is used as the reference voltage for the IC's internal circuit.

The reference voltage can be used to supply a load current of up to 1 mA to an external device through the VREF terminal (pin 8) .

(2) Triangular-wave oscillator block (OSC)

The triangular waveform oscillator incorporates a triangular oscillation frequency setting capacitor connected respectively to the RT terminal (pin 5) to generate triangular oscillation waveforms CT1 (amplitude of 1.8 V to 3.0 V) and CT2 (amplitude of 1.8 V to 3.0 V in antiphase with CT1). The symmetrical-phase system using the two opposite-phase triangular waves reduces the input ripple current, resulting in a smaller input capacitor.

The triangular oscillation waveforms are input to the IC's internal PWM comparator.

(3) Error amplifier block (Error Amp1, Error Amp2)

The error amplifier detects the DC/DC converter output voltage and outputs PWM control signals. By connecting a feedback resistor and capacitor between the output terminal and inverted input terminal, it is possible to create any desired level of loop gain, thereby providing stable phase compensation to the system.

Also, it is possible to prevent rush current at power supply start-up by connecting a soft-start capacitor to the CS1 terminal (pin 3) or CS2 terminal (pin 13), the non-inverted input terminal for Error Amp. The use of Error Amp for soft-start detection makes it possible for a system to operate on a fixed soft-start time that is independent of the output load on the DC/ DC converter.

(4) PWM comparator block (PWM Comp.)

The PWM comparator is a voltage-pulse width modulator that controls the output duty depending on the input/output voltage.

Main side : Turns the output transistor on in the intervals in which the error amplifier output voltage is higher than the triangular wave voltage.

Synchronous rectification side : Turns the output transistor on in the intervals in which the error amplifier output voltage is lower than the triangular wave voltage.

(5) Output block

The output circuits on the main side and on the synchronous rectification side are both in the totem pole configuration, capable of driving an external N-ch MOS FET.

In addition, because the output drive ability (700 mA Max : Duty \leq 5%) is high, the gate – source capacity is large and the FET of low ON resistor can be used.

2. Channel Control Function

Channels, main, VB and PWRGOOD are turned on and off depending on the voltage levels at the CTL terminal (pin 6), CTL1 terminal (pin 9) and CTL2 terminal (pin 10).

Channel On/Off Setting Conditions

CTL	CTL1	CTL2	Power	CH1	CH2	VB	PWRGOOD
L	—*	—*	OFF	OFF	OFF	OFF	OFF
H	L	L	ON	OFF	OFF	ON	ON
H	H	L	ON	ON	OFF	ON	ON
H	L	H	ON	OFF	ON	ON	ON
H	H	H	ON	ON	ON	ON	ON

*: Undefined

3. Protective Functions

(1) Undervoltage lockout protection circuit (UVLO)

The transient state or a momentary drops in supply voltage, which occurs when the power supply is turned on, may cause the control IC to malfunction, resulting in breakdown or degradation of the system. To prevent such malfunctions, the undervoltage lockout protection circuit detects the internal reference voltage level with respect to the power supply voltage, turns off the output transistor, and sets the dead time to 100% while holding the CSCP terminal (pin 11) at the “L” level and setting the PWRGOOD terminal (pin 12) to the “L” level.

The system is restored when the supply voltage reaches the threshold voltage of the undervoltage lockout protection circuit.

(2) Timer-latch overcurrent protection circuit block (OCP)

The timer-latch overcurrent protection circuit is actuated upon completion of the soft-start period. When an overcurrent flows, the circuit detects the increase in the voltage between the main-side FET's drain and source using the main-side FET ON resistor, actuates the timer circuit, and starts charging the capacitor C_{SCP} connected to the CSCP terminal (pin 11). If the overcurrent remains flowing beyond the predetermined period of time, the circuit sets the latch to turn off the FETs on the main side and synchronous rectification side of each channel while setting the PWRGOOD terminal (pin 12) to the “L” level. The detection current value can be set by resistor R_{LIM1} connected between the main-side FET's drain and the ILIM1 terminal (pin 25) and resistor R_{LIM2} connected between the drain and the ILIM2 terminal (pin 23).

To reset the actuated protection circuit, either the power supply turn off and on again or set the CTL terminal (pin 6) to the “L” level to lower the VREF terminal (pin 8) voltage to 1.7 V (Min) or less. It can also be reset by setting both of the CTL1 terminal (pin 9) and CTL2 terminal (pin 10) to the “L” level. (Refer to “1. Setting Timer-Latch Overcurrent Detection Current” in ■ ABOUT TIMER-LATCH PROTECTION CIRCUIT.)

(3) Timer-latch short-circuit protection circuit (SCP)

The short-circuit detection comparator (SCP Comp.) detects the output voltage level and, if the error amplifier output voltage of either channel reaches the short-circuit detection voltage (typically 3.1 V), the timer circuit is actuated to start charging the external capacitor C_{SCP} connected to the CSCP terminal (pin 11).

When the capacitor voltage reaches about 0.7 V, the circuit turns off the output transistor and sets the dead time to 100%.

The PWRGOOD terminal (pin 12) is fixed at the “L” level.

To reset the actuated protection circuit, either the power supply turn off and on again or set the CTL terminal (pin 6) to the “L” level to lower the VREF terminal (pin 8) voltage to 1.7 V (Min) or less. It can also be reset by setting both of the CTL1 terminal (pin 9) and CTL2 terminal (pin 10) to the “L” level. (Refer to “2. Setting Time Constant for Timer-Latch Short-Circuit Protection Circuit” in ■ ABOUT TIMER-LATCH PROTECTION CIRCUIT.)

(4) Timer-latch overvoltage protection circuit block (OVP)

When the overvoltage detection comparator (OVP Comp.) provided for each channel detects the DC/DC converter's output voltage level exceeding its threshold voltage, the timer-latch overvoltage protection circuit actuates the timer circuit and starts charging the capacitor C_{SCP} connected to the CSCP terminal (pin 11). If the overvoltage remains applied beyond the predetermined period of time, the circuit sets the latch to turn off the FET on the main side of each channel while setting the PWRGOOD terminal (pin 12) to the "L" level.

To reset the actuated protection circuit, either the power supply turn off and on again or set the CTL terminal (pin 6) to the "L" level to lower the VREF terminal (pin 8) voltage to 1.7 V (Min) or less. It can also be reset by setting both of the CTL1 terminal (pin 9) and CTL2 terminal (pin 10) to the "L" level. (Refer to "3. Setting Overvoltage Detection by the Timer-Latch Overvoltage Protection Circuit" in ■ ABOUT TIMER-LATCH PROTECTION CIRCUIT.)

(5) Protection status output circuit block (PWRGOOD)

The protection status output circuit outputs the "L" level signal to the PWRGOOD terminal (pin 12) when each protection circuit is actuated.

■ SETTING THE OUTPUT VOLTAGE

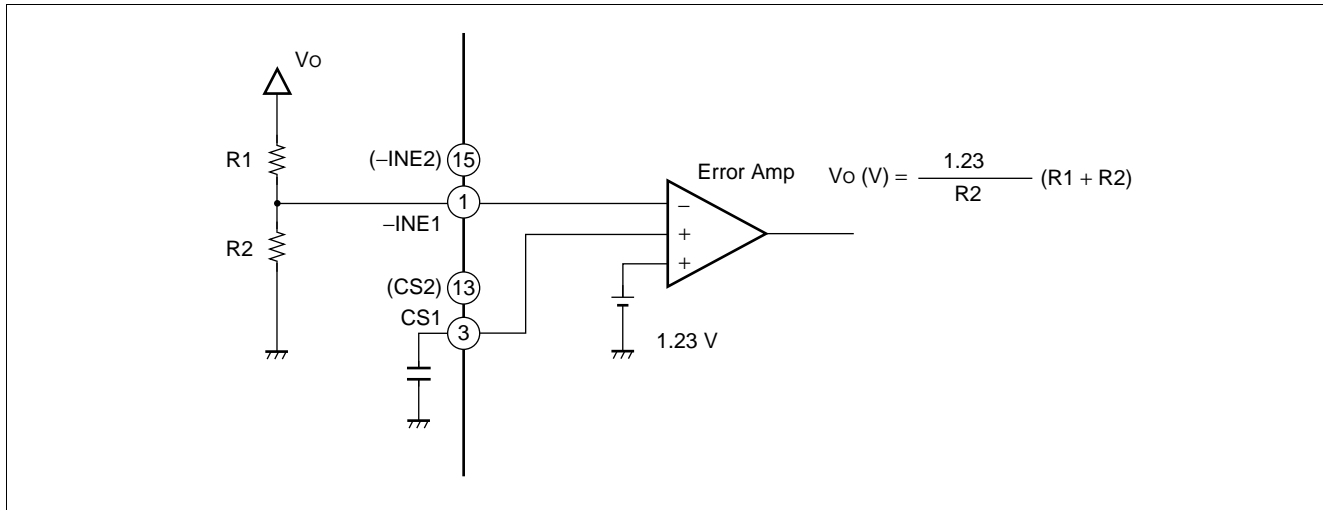

< CH1, CH2 >

■ SETTING THE TRIANGULAR OSCILLATION FREQUENCY

The triangular oscillation frequency is determined by the timing resistor (R_T) connected to the RT terminal (pin 5).

Triangular oscillation frequency: f_{osc}

$$f_{osc} \text{ (kHz)} \doteq \frac{14100}{R_T \text{ (k}\Omega\text{)}}$$

■ SETTING THE SOFT-START AND DISCHARGE TIMES

To prevent rush currents when the IC is turned on, you can set a soft-start by connecting soft-start capacitors (C_{S1} and C_{S2}) to the CS1 terminal (pin 3) for channel 1 and the CS2 terminal (pin 13) for channel 2, respectively.

Setting the each control terminals (CTL1 and CTL2) from “L” to “OPEN” switches SW1 and SW2 from B to A to charge the external soft-start capacitors (C_{S1} and C_{S2}) connected to the CS1 and CS2 terminals at $3\ \mu\text{A}$.

The error amplifier output (FB1 or FB2) is determined by comparison between the lower one of the potentials at two noninverted input terminals (1.23 V, CS terminal voltages) and the inverted input terminal voltage (-INE).

The FB terminal voltage during the soft-start period is therefore determined by comparison between the -INE terminal and CS terminal voltages. The DC/DC converter output voltage rises in proportion to the CS terminal voltage as the soft-start capacitor connected to the CS terminal is charged.

The soft-start time is obtained from the following equation:

Soft-start time: t_s (time to output 100%)

$$t_s (\text{s}) \approx 0.41 \times C_s (\mu\text{F})$$

Setting the each control terminals (CTL1 and CTL2) from “OPEN” to “L” switches SW1 and SW2 from A to B.

Then the IC discharges the soft-start capacitors (C_{S1} and C_{S2}) charged at about 3.4 V using the internally set discharge resistor ($R_s \approx 6\ \text{k}\Omega$) and lowers the output voltage regardless of the DC/DC converter load current.

The discharge time is obtained from the following equation:

Discharge time: t_{off} (time to output 10%)

$$t_{off} (\text{s}) \approx 0.020 \times C_s (\mu\text{F})$$

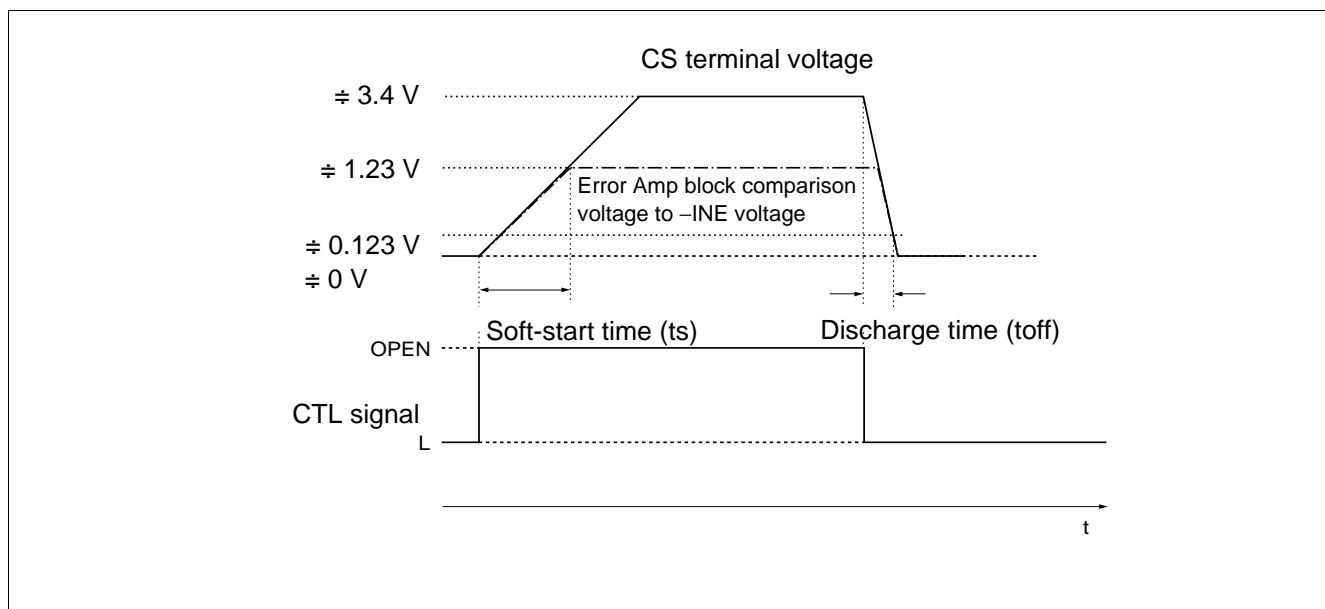

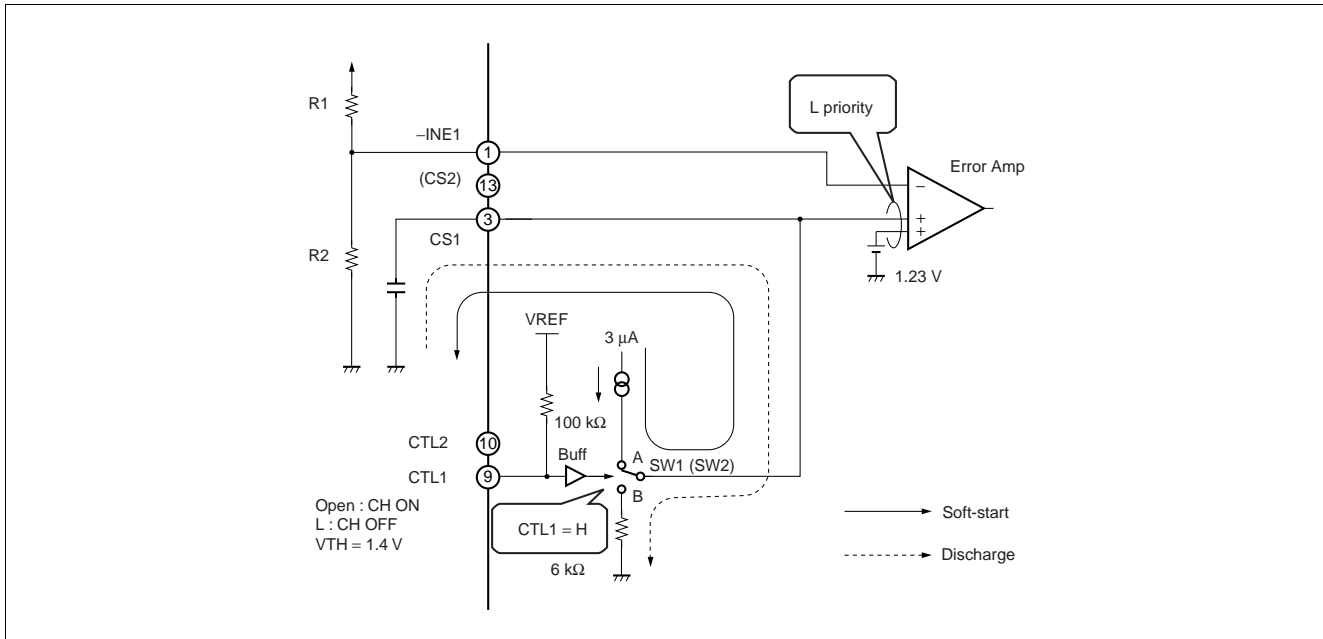

<Soft-start circuit>

■ TREATMENT OF UNUSED CS TERMINALS

When the soft-start function is not used, the CS1 terminal (pin 3) and CS2 terminal (pin 13) should be left open.

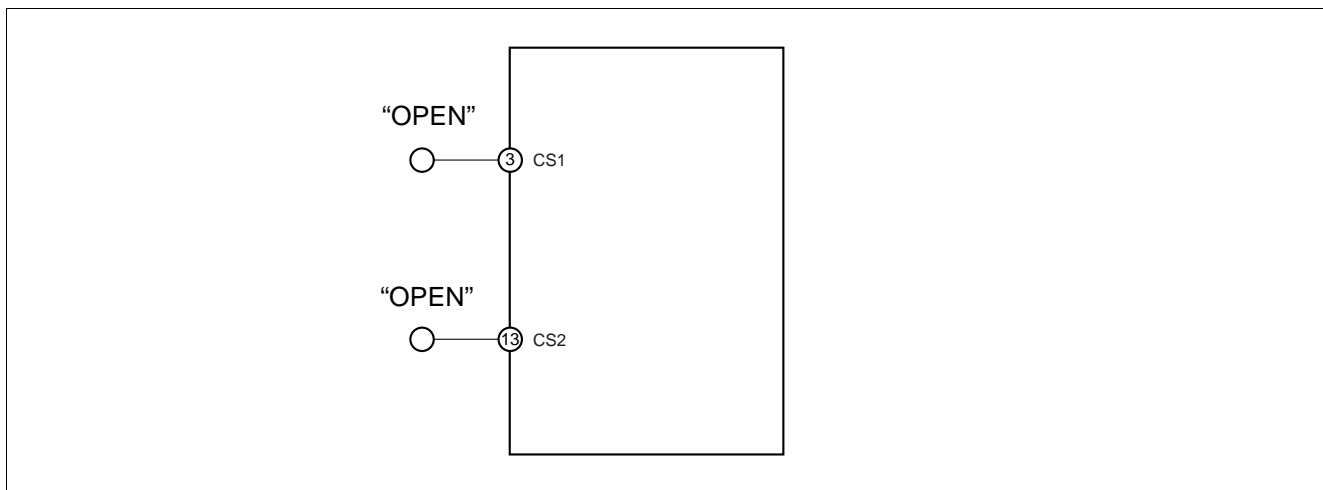

< Operation Without Soft-start Setting >

■ ABOUT TIMER-LATCH PROTECTION CIRCUIT

1. Setting Timer-Latch Overcurrent Detection Current

The overcurrent protection circuit is actuated upon completion of the soft-start period. When an overcurrent flows, the circuit detects the increase in the voltage between the main-side FET's drain and source using the main-side FET ON resistor (R_{ON}), actuates the timer circuit, and starts charging the capacitor C_{SCP} connected to the CSCP terminal (pin 11). If the overcurrent remains flowing beyond the predetermined period of time, the circuit sets the latch to turn off the FETs on the main side and synchronous rectification side of each channel while setting the PWRGOOD terminal (pin 12) to the "L" level. The detection current value can be set by the resistors (R_{LIM1} and R_{LIM2}) connected between the main-side FET's drain and the ILIM1 terminal (pin 25) and between the drain and the ILIM2 terminal (pin 23), respectively.

The internal current (I_{LIM}) can be set by the timing resistor (R_T) connected to the RT terminal (pin 5).

Internal current value: I_{LIM}

$$I_{LIM} (\mu A) \doteq \frac{5546}{R_T (k\Omega)}$$

Detection current value: I_{OCP}

$$I_{OCP} (A) \doteq \frac{I_{LIM}(A) \times R_{LIM}(\Omega)}{R_{ON} (\Omega)} - \frac{(V_{IN}(V) - V_o(V)) \times V_o(V)}{2 \times V_{IN}(V) \times f_{osc}(Hz) \times L(H)}$$

R_{LIM} : Overcurrent detection resistor

R_{ON} : Main-side FET ON resistor

V_{IN} : Input voltage

V_o : DC/DC converter output voltage

f_{osc} : Oscillation frequency

L: Coil inductance

To reset the actuated protection circuit, either the power supply turn off and on again or set the CTL terminal (pin 6) to the "L" level to lower the VREF terminal (pin 8) voltage to 1.7 V (Min) or less. It can also be reset by setting both of the CTL1 terminal (pin 9) and CTL2 terminal (pin 10) to the "L" level.

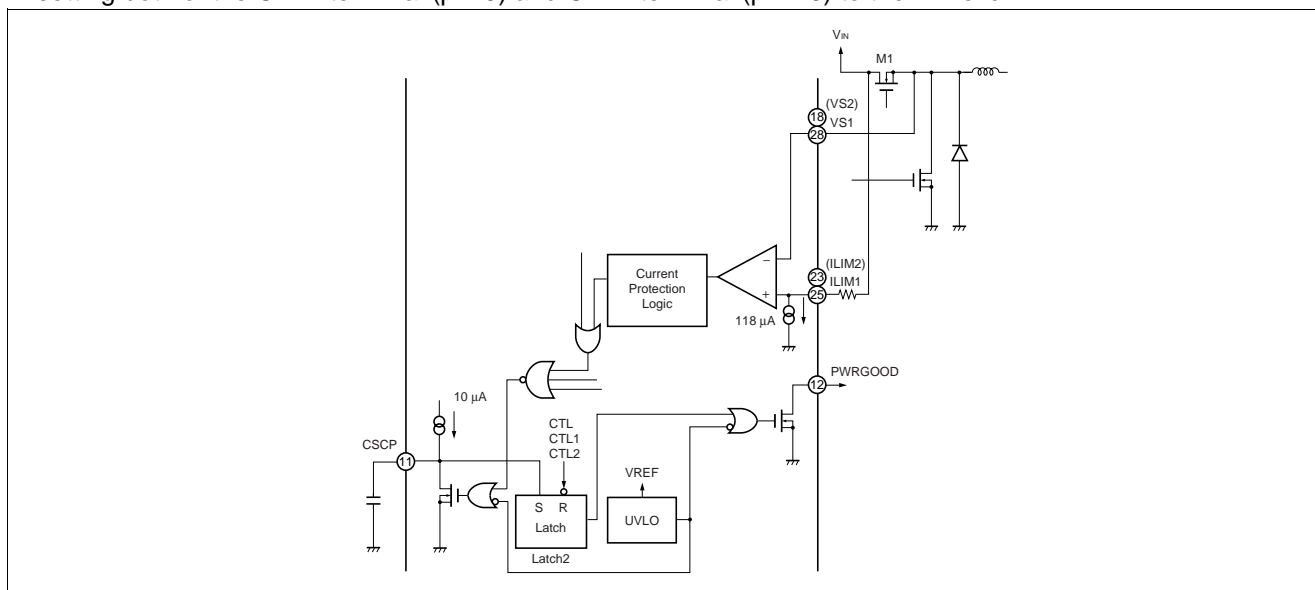

<Overcurrent detection circuit>

2. Setting Time Constant for Timer-Latch Short-Circuit Protection Circuit

Each channel uses the short-circuit detection comparator (SCP Comp.) to always compare the error amplifier's output level to the reference voltage.

While the DC/DC converter load conditions are stable on both channels, the short-circuit detection comparator keeps its output at the "H" level and the CSCP terminal (pin 11) remains at the "L" level.

If a load condition changes rapidly due to a short-circuit of the load, causing the output voltage to drop, the short-circuit detection comparator changes its output to the "L" level. This causes the external short-circuit protection capacitor C_{SCP} connected to the CSCP terminal to be charged at $10 \mu\text{A}$.

Short-circuit detection time (t_{SCP})

$$t_{SCP} \text{ (s)} \approx 0.070 \times C_{SCP} \text{ (\mu F)}$$

When capacitor C_{SCP} is charged to the threshold voltage ($V_{TH} \approx 0.70 \text{ V}$), the protection circuit sets the latch and turns off the external FET (setting the dead time to 100%). At this time, the latch input is closed. As the result, the CSCP terminal is held at the "L" level and the PWRGOOD terminal is set to "L" level. The protection circuit closes both channels even when a short-circuit is detected on only either.

To reset the actuated protection circuit, either the power supply turn off and on again or set the CTL terminal (pin 6) to the "L" level to lower the VREF terminal (pin 8) voltage to 1.7 V (Min) or less. It can also be reset by setting both of the CTL1 terminal (pin 9) and CTL2 terminal (pin 10) to the "L" level.

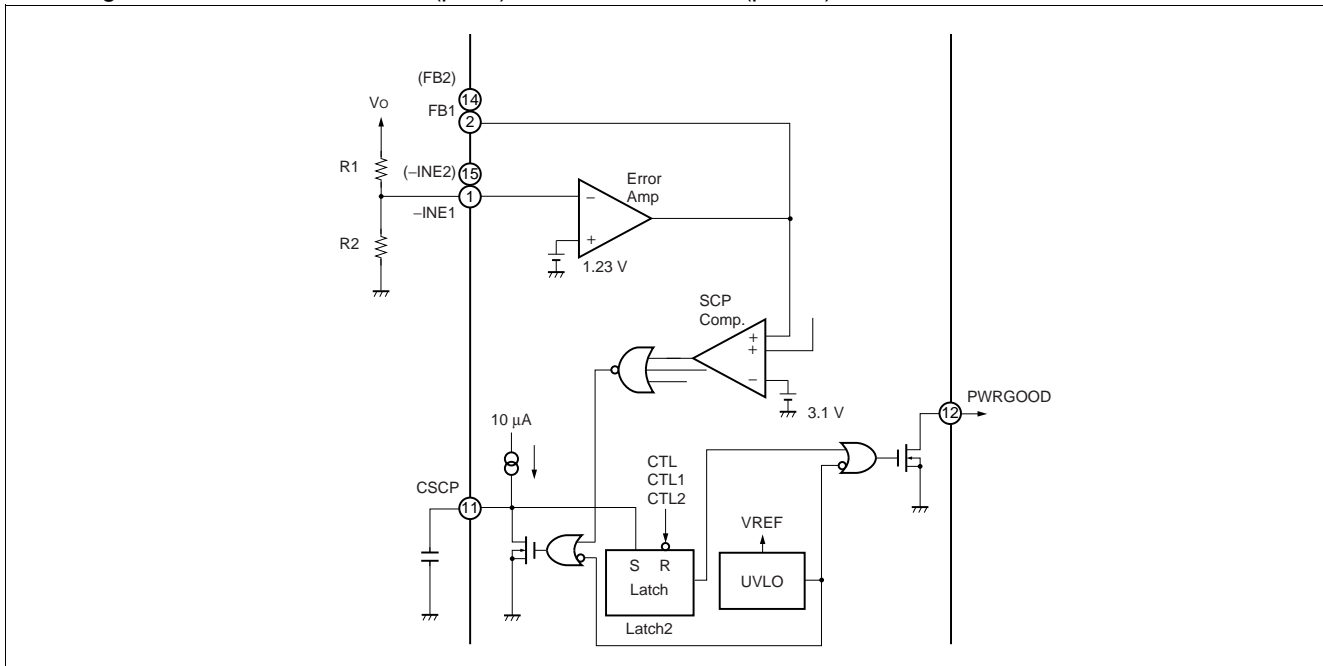

<Timer-latch short-circuit protection circuit>

3. Setting Overvoltage Detection by the Timer-Latch Overvoltage Protection Circuit

An overvoltage output from the DC/DC converter can be detected by connecting external resistors from the DC/DC converter output to the noninverted input terminal (-INE1 terminal (pin 1) and -INE2 terminal (pin 15)) of the overvoltage comparators (OVP Comp. 1 and OVP Comp. 2).

When the DC/DC converter output voltage exceeds the overvoltage detection level, the output of the overvoltage comparator (OVP Comp. 1 and OVP Comp. 2) becomes the "H" level and the overvoltage protection circuit actuates the timer circuit to start charging the external capacitor Cscp connected to the CSCP terminal (pin 11). If the overvoltage remains applied beyond setting time, the circuit sets the latch to turn off the FET on the main side of each channel while setting the PWRGOOD terminal (pin 12) to the "L" level. The protection circuit closes both channels even when an overvoltage is detected on only either.

Overvoltage detection voltage : V_{OVP}

$$V_{OVP} (V) \doteq 1.38 \times (R1 (\Omega) + R2 (\Omega)) / R2 (\Omega) \doteq 1.12 \times V_o$$

To reset the actuated protection circuit, either the power supply turn off and on again or set the CTL terminal (pin 6) to the "L" level to lower the VREF terminal (pin 8) voltage to 1.7 V (Min) or less. It can also be reset by setting both of the CTL1 terminal (pin 9) and CTL2 terminal (pin 10) to the "L" level.

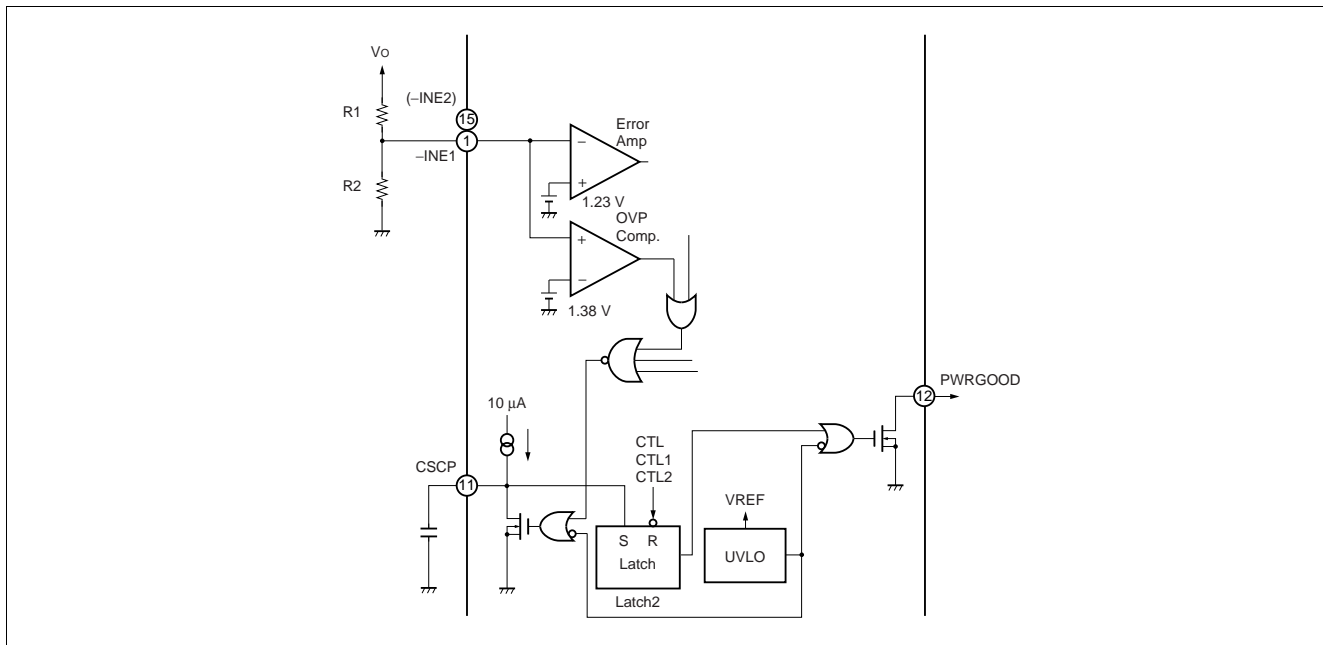

<Timer-latch overvoltage protection circuit>

■ TREATMENT OF UNUSED ILIM TERMINALS

When the overcurrent protection circuit is not used, the ILIM1 terminal (pin 25) and ILIM2 terminal (pin 23) should be shorted to the SGND terminal.

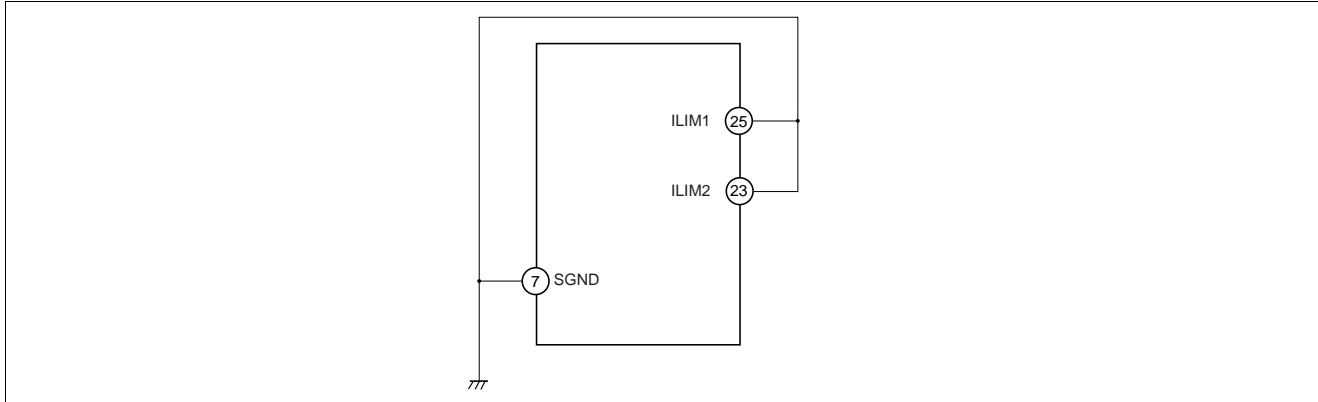

<Operation Without Using the ILIM Terminals>

■ PROCESSING WITHOUT USING THE CSCP TERMINAL

When the timer-latch short-circuit protection circuit is not used, the CSCP terminal (pin 11) should be shorted to SGND using the shortest possible connection.

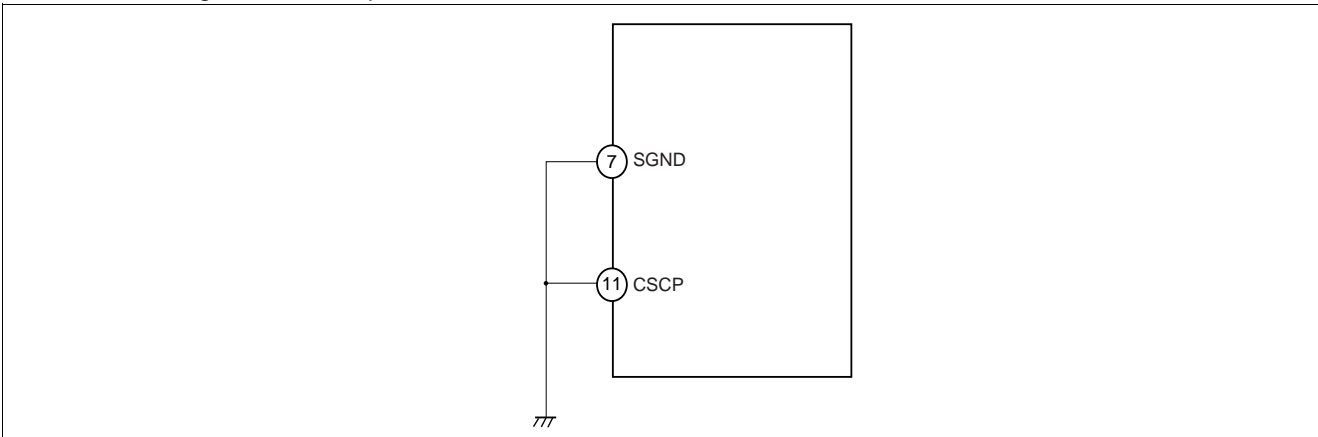

<Operation Without Using the CSCP Terminal>

■ TREATMENT OF UNUSED PWRGOOD TERMINALS

When the PWRGOOD terminal is not used, the PWRGOOD terminal (pin 12) should be shorted or open to the SGND terminal.

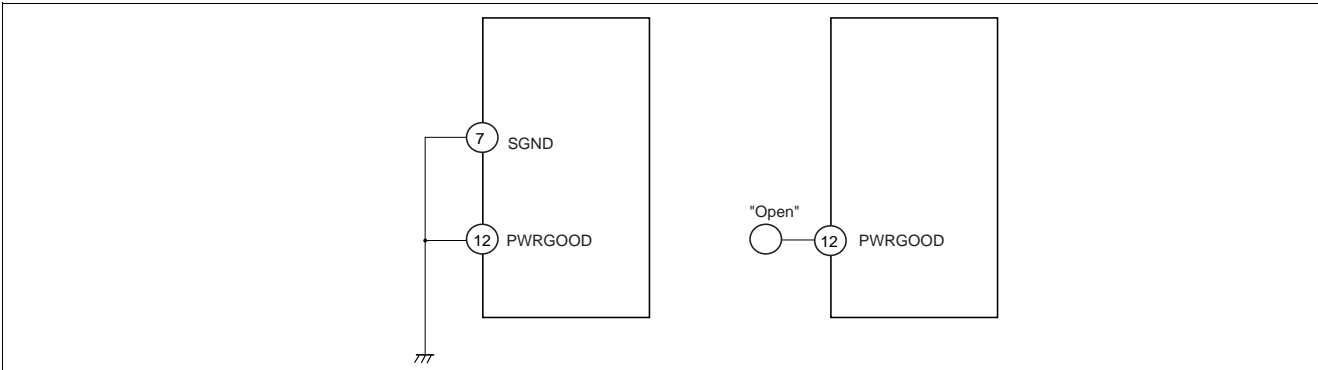

<Operation Without Using the PWRGOOD Terminals>

■ OUTPUT STATES DURING PROTECTION CIRCUIT OPERATION

The table below lists the output states with each protection circuit actuated.

Protection circuit		CH1		CH2		PWRGOOD
		OUT1-1	OUT2-1	OUT1-2	OUT2-2	
Overcurrent protection circuit	CH1	L	L	L	L	L
	CH2	L	L	L	L	L
Overvoltage protection circuit	CH1	L	H	L	H	L
	CH2	L	H	L	H	L
Short-circuit protection	CH1	L	L	L	L	L
	CH2	L	L	L	L	L
Under voltage lockout protection circuit		L	L	L	L	L

■ RESETTING THE LATCH OF EACH PROTECTION CIRCUIT

When the overvoltage, overcurrent, or short-circuit protection circuit detects each abnormality, it sets the latch to fix the output at the "L" level. The PWRGOOD terminal (pin 12) is fixed at the "L" level upon abnormality detection by each protection circuit.

To reset the actuated protection circuit, either the power supply turn off and on again or set the CTL terminal (pin 6) to the "L" level to lower the VREF terminal (pin 8) voltage to 1.7 V (Min) or less. It can also be reset by setting both of the CTL1 terminal (pin 9) and CTL2 terminal (pin 10) to the "L" level.

Power Consumption vs. Input Voltage (Qg Parameter)

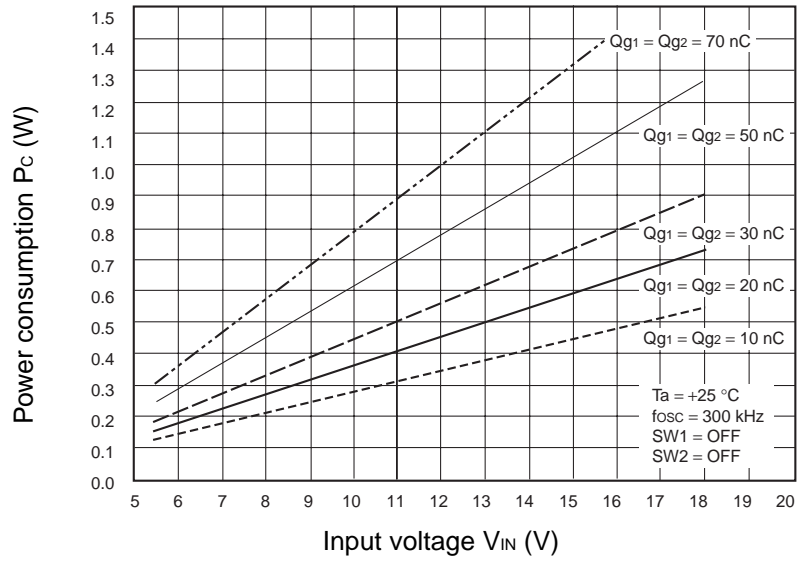

Power Consumption vs. Input Voltage (f_{osc} Parameter)

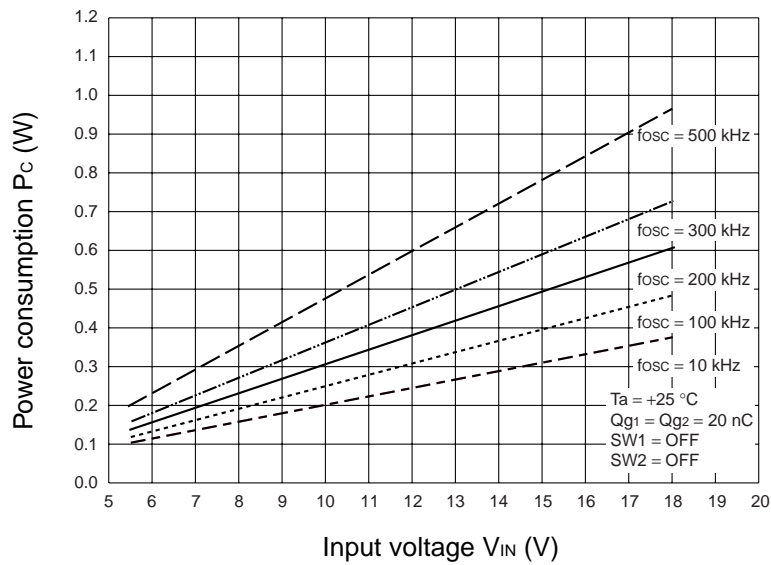

MB39A106

I/O EQUIVALENT CIRCUIT

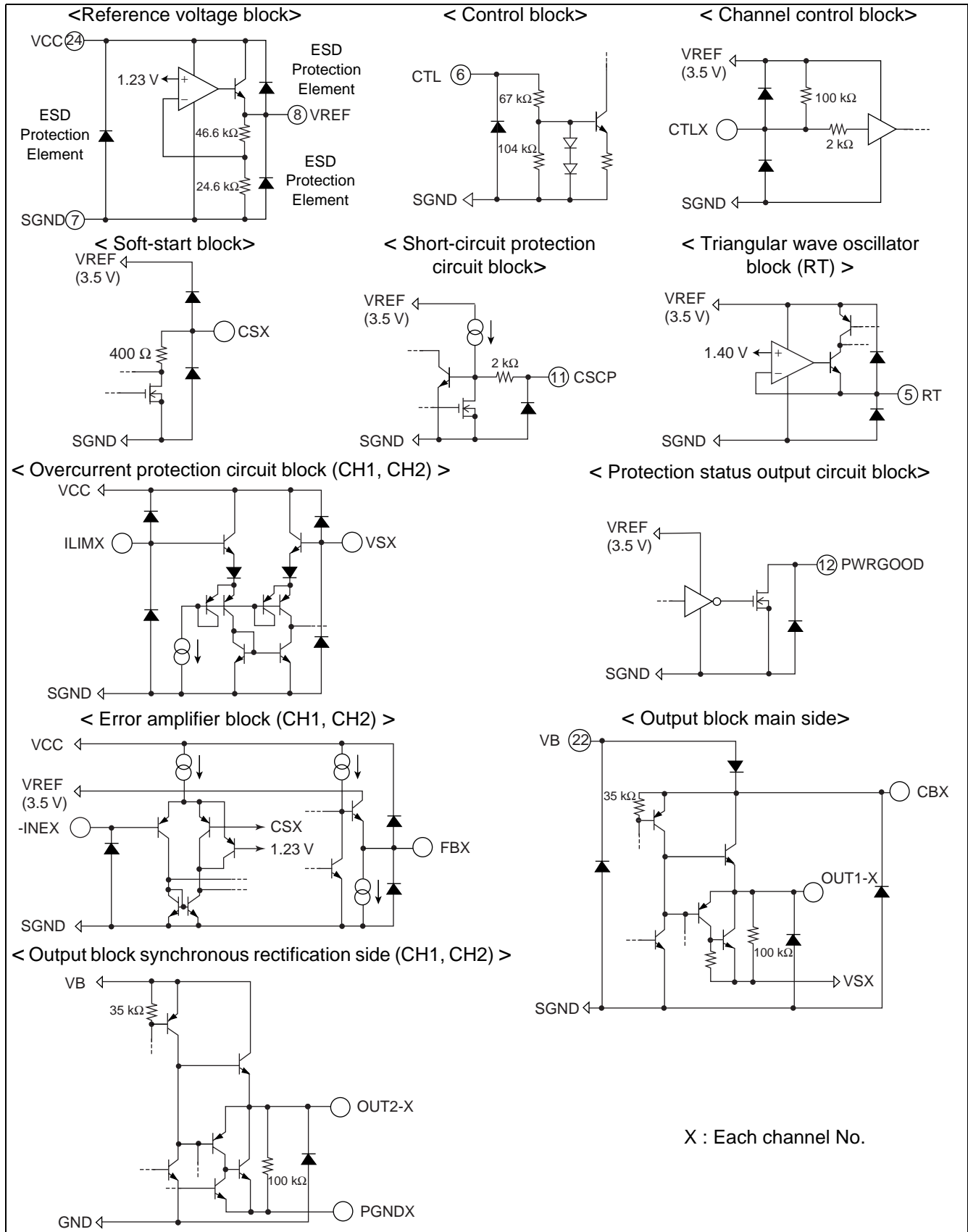

APPLICATION EXAMPLE

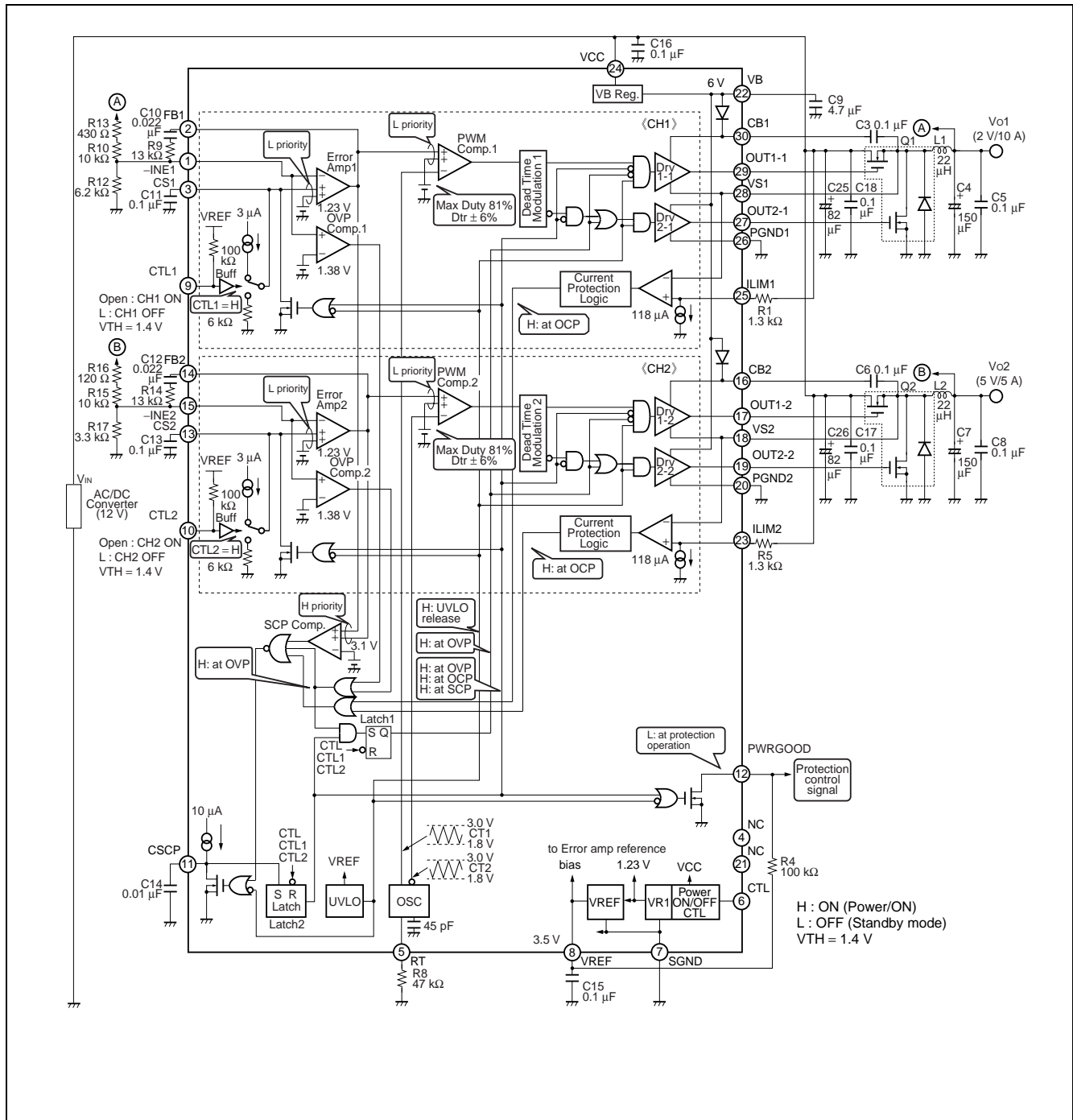

MB39A106

■ PARTS LIST

COMPONENT	ITEM	SPECIFICATION		VENDOR	PARTS NO.
Q1, Q2	Dual FETKY™	Main sides: VDS = 30 V, Qg = 9.9 nC (Max) Synchronous sides: VDS = 30 V, Qg = 20.7 nC (Max) SBD: VF = 0.52 V (Max) at IF = 1 A		IR	IRF7901D1
L1, L2	Coil	22 μH	3.5 A, 31.6 mΩ	TDK	SLF12565T-220M3R5
C3, C6	Ceramics Condenser	0.1 μF	50 V	TDK	C1608JB1H104K
C4	OS-CON™	150 μF	6.3 V	SANYO	6SVP150M
C5, C8	Ceramics Condenser	0.1 μF	50 V	TDK	C1608JB1H104K
C7	OS-CON™	150 μF	6.3 V	SANYO	6SVP150M
C9	Ceramics Condenser	4.7 μF	10 V	TDK	C3216JB1A475M
C10	Ceramics Condenser	0.022 μF	50 V	TDK	C1608JB1H223K
C11, C13	Ceramics Condenser	0.1 μF	50 V	TDK	C1608JB1H104K
C12	Ceramics Condenser	0.022 μF	50 V	TDK	C1608JB1H223K
C14	Ceramics Condenser	0.01 μF	50 V	TDK	C1608JB1H103K
C15, C16	Ceramics Condenser	0.1 μF	50 V	TDK	C1608JB1H104K
C17, C18	Ceramics Condenser	0.1 μF	50 V	TDK	C1608JB1H104K
C25, C26	OS-CON™	82 μF	16 V	SANYO	16SVP82M
R1, R5	Resistor	1.3 Ω	0.5 %	ssm	RR0816P132D
R4	Resistor	100 kΩ	0.5 %	ssm	RR0816P104D
R8	Resistor	47 kΩ	0.5 %	ssm	RR0816P473D
R9	Resistor	13 kΩ	0.5 %	ssm	RR0816P133D
R10	Resistor	10 kΩ	0.5 %	ssm	RR0816P103D
R12	Resistor	6.2 kΩ	0.5 %	ssm	RR0816P622D
R13	Resistor	430 Ω	0.5 %	ssm	RR0816P434D
R14	Resistor	13 kΩ	0.5 %	ssm	RR0816P133D
R15	Resistor	10 kΩ	0.5 %	ssm	RR0816P103D
R16	Resistor	120 Ω	0.5 %	ssm	RR0816P124D
R17	Resistor	3.3 kΩ	0.5 %	ssm	RR0816P332D

Note : IR : International Rectifier Corp.

TDK : TDK Corporation

SANYO : SANYO Electric Co., Ltd.

ssm : SUSUMU Electronics Corp.

Dual FETKY is a trademark of International Rectifier Corp.

OS-CON is a trademark of SANYO Electric Co., Ltd.

■ SELECTION OF COMPONENTS

• N-ch MOS FET

The N-ch MOS FET for switching use should be rated for at least 20% more than the maximum input voltage. To minimize continuity loss, use a FET with low $R_{DS(ON)}$ between the drain and source. For high input voltage and high frequency operation, on/off-cycle switching loss will be higher so that power dissipation must be considered. In this application, the IR IRF7901D1 is used. Continuity loss, on/off switching loss, and total loss are determined by the following formulas. The selection must ensure that peak drain current does not exceed rated values, and also must be in accordance with overcurrent detection levels.

Continuity loss : P_C

$$P_C = I_D^2 \times R_{DS(ON)} \times \text{Duty}$$

On-cycle switching loss : $P_S(ON)$

$$P_S(ON) = \frac{V_D(\text{Max}) \times I_D \times t_r \times f_{OSC}}{6}$$

Off-cycle switching loss : $P_S(OFF)$

$$P_S(OFF) = \frac{V_D(\text{Max}) \times I_D(\text{Max}) \times t_f \times f_{OSC}}{6}$$

Total loss : P_T

$$P_T = P_C + P_S(ON) + P_S(OFF)$$

Example: Using the IR IRF7901D1

CH1 Main side

Input voltage $V_{IN(\text{Max})} = 15 \text{ V}$, output voltage $V_O = 3.3 \text{ V}$, drain current $I_D = 3 \text{ A}$, Oscillation frequency $f_{OSC} = 300 \text{ kHz}$, $L = 22 \mu\text{H}$, drain-source on resistance $R_{DS(ON)} \cong 33 \text{ m}\Omega$, $t_r = 13.8 \text{ ns}$, $t_f = 8 \text{ ns}$.

Drain current (Max) : $I_D(\text{Max})$

$$\begin{aligned} I_D(\text{Max}) &= I_O + \frac{V_{IN(\text{Max})} - V_O}{2L} \times t_{on} \\ &= 3 + \frac{15 - 3.3}{2 \times 22 \times 10^{-6}} \times \frac{1}{300 \times 10^3} \times 0.22 \\ &\cong \underline{3.20 \text{ (A)}} \end{aligned}$$

Drain current (Min) : $I_D(\text{Min})$

$$\begin{aligned} I_D(\text{Min}) &= I_O - \frac{V_{IN(\text{Max})} - V_O}{2L} \times t_{on} \\ &= 3 - \frac{15 - 3.3}{2 \times 22 \times 10^{-6}} \times \frac{1}{300 \times 10^3} \times 0.22 \\ &\cong \underline{2.80 \text{ (A)}} \end{aligned}$$

MB39A106

$$\begin{aligned}P_{C1} &= I_D^2 \times R_{DS(ON)} \times \text{Duty}_{(ON)} \\ &= 3^2 \times 0.033 \times 0.22 \\ &\doteq \underline{0.065 \text{ W}}\end{aligned}$$

$$\begin{aligned}P_{S1(ON)} &= \frac{V_D(\text{Max}) \times I_D \times t_r \times f_{osc}}{6} \\ &= \frac{15 \times 3 \times 13.8 \times 10^{-9} \times 300 \times 10^3}{6} \\ &\doteq \underline{0.031 \text{ W}}\end{aligned}$$

$$\begin{aligned}P_{S1(OFF)} &= \frac{V_D(\text{Max}) \times I_D(\text{Max}) \times t_f \times f_{osc}}{6} \\ &= \frac{15 \times 3.2 \times 8 \times 10^{-9} \times 300 \times 10^3}{6} \\ &\doteq \underline{0.019 \text{ W}}\end{aligned}$$

$$\begin{aligned}P_{T1} &= P_{C1} + P_{S1(ON)} + P_{S1(OFF)} \\ &\doteq 0.065 + 0.031 + 0.019 \\ &\doteq \underline{0.115 \text{ W}}\end{aligned}$$

CH1 (Synchronous rectification side)

Input voltage $V_{IN(\text{Max})} = 15 \text{ V}$, output voltage $V_o = 3.3 \text{ V}$, drain current $I_D = 3 \text{ A}$, oscillation frequency $f_{osc} = 300 \text{ kHz}$, $L = 22 \mu\text{H}$, drain-source on resistance $R_{DS(ON)} \doteq 28 \text{ m}\Omega$, $t_r = 16.4 \text{ ns}$, $t_f = 5.2 \text{ ns}$.

Drain current (Max) : $I_{D(\text{Max})}$

$$\begin{aligned}I_{D(\text{Max})} &= I_o + \frac{V_o}{2L} \text{toff} \\ &= 3 + \frac{3.3}{2 \times 22 \times 10^{-6}} \times \frac{1}{300 \times 10^3} \times (1-0.22) \\ &\doteq \underline{3.20 \text{ (A)}}\end{aligned}$$

Drain current (Min) : $I_{D(\text{Min})}$

$$\begin{aligned}I_{D(\text{Min})} &= I_o - \frac{V_o}{2L} \text{toff} \\ &= 3 - \frac{3.3}{2 \times 22 \times 10^{-6}} \times \frac{1}{300 \times 10^3} \times (1-0.22) \\ &\doteq \underline{2.80 \text{ (A)}}\end{aligned}$$

$$\begin{aligned} P_{C2} &= I_D^2 \times R_{DS(ON)} \times \text{Duty}_{(OFF)} \\ &= 3^2 \times 0.028 \times (1-0.22) \\ &\doteq \underline{0.197 \text{ W}} \end{aligned}$$

$$\begin{aligned} P_{S2(ON)} &= \frac{V_D(\text{Max}) \times I_D \times t_r \times f_{OSC}}{6} \\ &= \frac{15 \times 3 \times 16.4 \times 10^{-9} \times 300 \times 10^3}{6} \\ &\doteq \underline{0.037 \text{ W}} \end{aligned}$$

$$\begin{aligned} P_{S2(OFF)} &= \frac{V_D(\text{Max}) \times I_D(\text{Max}) \times t_f \times f_{OSC}}{6} \\ &= \frac{15 \times 3.2 \times 5.2 \times 10^{-9} \times 300 \times 10^3}{6} \\ &\doteq \underline{0.012 \text{ W}} \end{aligned}$$

$$\begin{aligned} P_{T2} &= P_{C2} + P_{S2(ON)} + P_{S2(OFF)} \\ &\doteq 0.197 + 0.037 + 0.012 \\ &\doteq \underline{0.246 \text{ W}} \end{aligned}$$

$$\begin{aligned} P_T &= P_{T1} + P_{T2} \\ &\doteq 0.115 + 0.246 \\ &\doteq \underline{0.361 \text{ W}} \end{aligned}$$

The above power dissipation figures for the IRF7901D1 are satisfied with ample margin at 2W (Ta = +100 °C) .

MB39A106

CH2 (Main side)

Input voltage $V_{IN (Max)} = 15 \text{ V}$, output voltage $V_O = 5 \text{ V}$, drain current $I_D = 3 \text{ A}$, Oscillation frequency $f_{osc} = 300 \text{ kHz}$, $L = 22 \mu\text{H}$, drain-source on resistance $R_{DS (ON)} \approx 33 \text{ m}\Omega$, $t_r = 13.8 \text{ ns}$, $t_f = 8 \text{ ns}$.

Drain current (Max) : $I_{D (Max)}$

$$\begin{aligned} I_{D (Max)} &= I_O + \frac{V_{IN (Max)} - V_O}{2L} t_{on} \\ &= 3 + \frac{15-5}{2 \times 22 \times 10^{-6}} \times \frac{1}{300 \times 10^3} \times 0.33 \\ &\approx \underline{3.25 \text{ (A)}} \end{aligned}$$

Drain current (Min) : $I_{D (Min)}$

$$\begin{aligned} I_{D (Min)} &= I_O + \frac{V_{IN (Max)} - V_O}{2L} t_{on} \\ &= 3 - \frac{15-5}{2 \times 22 \times 10^{-6}} \times \frac{1}{300 \times 10^3} \times 0.33 \\ &\approx \underline{2.75 \text{ (A)}} \end{aligned}$$

$$\begin{aligned} P_{C1} &= I_D^2 \times R_{DS (ON)} \times \text{Duty}_{(ON)} \\ &= 3^2 \times 0.033 \times 0.33 \\ &\approx \underline{0.098 \text{ W}} \end{aligned}$$

$$\begin{aligned} P_{S1 (ON)} &= \frac{V_D (Max) \times I_D \times t_r \times f_{osc}}{6} \\ &= \frac{15 \times 3 \times 13.8 \times 10^{-9} \times 300 \times 10^3}{6} \\ &\approx \underline{0.031 \text{ W}} \end{aligned}$$

$$\begin{aligned} P_{S1 (OFF)} &= \frac{V_D (Max) \times I_D (Max) \times t_f \times f_{osc}}{6} \\ &= \frac{15 \times 3.25 \times 8 \times 10^{-9} \times 300 \times 10^3}{6} \\ &\approx \underline{0.020 \text{ W}} \end{aligned}$$

$$\begin{aligned} P_{T1} &= P_{C1} + P_{S1 (ON)} + P_{S1 (OFF)} \\ &\approx 0.098 + 0.031 + 0.020 \\ &\approx \underline{0.149 \text{ W}} \end{aligned}$$

CH2 (Synchronous rectification side)

Input voltage $V_{IN (Max)} = 15 \text{ V}$, output voltage $V_o = 5 \text{ V}$, drain current $I_D = 3 \text{ A}$, Oscillation frequency $f_{osc} = 300 \text{ kHz}$, $L = 22 \mu\text{H}$, drain-source on resistance $R_{DS (ON)} \approx 28 \text{ m}\Omega$, $t_r = 16.4 \text{ ns}$, $t_f = 5.2 \text{ ns}$.

Drain current (Max) : $I_{D (Max)}$

$$I_{D (Max)} = I_o + \frac{V_o}{2L} t_{off}$$

$$= 3 + \frac{5}{2 \times 22 \times 10^{-6}} \times \frac{1}{300 \times 10^3} \times (1-0.33)$$

$$\approx \underline{3.25 \text{ (A)}}$$

$$I_{D (Min)} = I_o - \frac{V_o}{2L} t_{off}$$

$$= 3 - \frac{5}{2 \times 22 \times 10^{-6}} \times \frac{1}{300 \times 10^3} \times (1-0.33)$$

$$\approx \underline{2.75 \text{ (A)}}$$

$$P_{C2} = I_D^2 \times R_{DS (ON)} \times \text{Duty}_{(OFF)}$$

$$= 3^2 \times 0.028 \times (1-0.33)$$

$$\approx \underline{0.169 \text{ W}}$$

$$P_{S2 (ON)} = \frac{V_D (Max) \times I_D \times t_r \times f_{osc}}{6}$$

$$= \frac{15 \times 3 \times 16.4 \times 10^{-9} \times 300 \times 10^3}{6}$$

$$\approx \underline{0.037 \text{ W}}$$

$$P_{S2 (OFF)} = \frac{V_D (Max) \times I_{D (Max)} \times t_f \times f_{osc}}{6}$$

$$= \frac{15 \times 3.25 \times 5.2 \times 10^{-9} \times 300 \times 10^3}{6}$$

$$\approx \underline{0.013 \text{ W}}$$

$$P_{T2} = P_{C2} + P_{S2 (ON)} + P_{S2 (OFF)}$$

$$\approx 0.169 + 0.037 + 0.013$$

$$\approx \underline{0.219 \text{ W}}$$

$$P_T = P_{T1} + P_{T2 (OFF)}$$

$$\approx 0.149 + 0.219$$

$$\approx \underline{0.368 \text{ W}}$$

The above power dissipation figures for the IRF7901D1 are satisfied with ample margin at 2W ($T_a = +100 \text{ }^\circ\text{C}$).

• Inductors

In selecting inductors, it is of course essential not to apply more current than the rated capacity of the inductor, but also to note that the lower limit for ripple current is a critical point that if reached will cause discontinuous operation and a considerable drop in efficiency. This can be prevented by choosing a higher inductance value, which will enable continuous operation under light loads. Note that if the inductance value is too high, however, direct current resistance (DCR) is increased and this will also reduce efficiency. The inductance must be set at the point where efficiency is greatest.

Note also that the DC superimposition characteristics become worse as the load current value approaches the rated current value of the inductor, so that the inductance value is reduced and ripple current increases, causing loss of efficiency. The selection of rated current value and inductance value will vary depending on where the point of peak efficiency lies with respect to load current.

Inductance values are determined by the following formulas.

The L value for all load current condition is set so that the peak to peak value of the ripple current is 1/2 the load current or less.

Inductance value : L

$$L \geq \frac{2 (V_{IN} - V_O)}{I_o} \text{ ton}$$

Example:

CH1

$$\begin{aligned} L &\geq \frac{2 (V_{IN (Max)} - V_O)}{I_o} \text{ ton} \\ &\geq \frac{2 \times (15 - 3.3)}{3} \times \frac{1}{300 \times 10^3} \times 0.22 \\ &\geq \underline{5.7 \mu\text{H}} \end{aligned}$$

CH2

$$\begin{aligned} L &\geq \frac{2 (V_{IN (Max)} - V_O)}{I_o} \text{ ton} \\ &\geq \frac{2 \times (15 - 5)}{3} \times \frac{1}{300 \times 10^3} \times 0.33 \\ &\geq \underline{7.3 \mu\text{H}} \end{aligned}$$

Inductance values derived from the above formulas are values that provide sufficient margin for continuous operation at maximum load current, but at which continuous operation is not possible at light loads. It is therefore necessary to determine the load level at which continuous operation becomes possible. In this application, the TDK SLF12565T-220M3R5 is used. At 22 μH , the load current value under continuous operating conditions is determined by the following formula.

Load current value under continuous operating conditions : I_o

$$I_o \geq \frac{V_O}{2L} \text{ toff}$$

Example : Using the SLF12565T-220M3R5

22 μH (allowable tolerance $\pm 20\%$) , rated current = 3.5 A

CH1

$$\begin{aligned}
 I_o &\geq \frac{V_o}{2L} \text{ toff} \\
 &\geq \frac{3.3}{2 \times 22 \times 10^{-6}} \times \frac{1}{300 \times 10^3} \times (1-0.22) \\
 &\geq \underline{195 \text{ mA}}
 \end{aligned}$$

CH2

$$\begin{aligned}
 I_o &\geq \frac{V_o}{2L} \text{ toff} \\
 &\geq \frac{5}{2 \times 22 \times 10^{-6}} \times \frac{1}{300 \times 10^3} \times (1-0.33) \\
 &\geq \underline{254 \text{ mA}}
 \end{aligned}$$

To determine whether the current through the inductor is within rated values, it is necessary to determine the peak value of the ripple current as well as the peak-to-peak values of the ripple current that affect the output ripple voltage. The peak value and peak-to-peak value of the ripple current can be determined by the following formulas.

Peak value : I_L

$$I_L \geq I_o + \frac{V_{IN} - V_o}{2L} \text{ ton}$$

Peak-to-peak value : ΔI_L

$$\Delta I_L = \frac{V_{IN} - V_o}{L} \text{ ton}$$

Example: Using the SLF12565T-220M3R5

22 μ H (allowable tolerance $\pm 20\%$), rated current = 3.5 A

Peak value

CH1

$$\begin{aligned}
 I_L &\geq I_o + \frac{V_{IN(\text{Max})} - V_o}{2L} \text{ ton} \\
 &\geq 3 + \frac{15-3.3}{2 \times 22 \times 10^{-6}} \times \frac{1}{300 \times 10^3} \times 0.22 \\
 &\geq \underline{3.20 \text{ A}}
 \end{aligned}$$

CH2

$$\begin{aligned}
 I_L &\geq I_o + \frac{V_{IN(\text{Max})} - V_o}{2L} \text{ ton} \\
 &\geq 3 + \frac{15-5}{2 \times 22 \times 10^{-6}} \times \frac{1}{300 \times 10^3} \times 0.33 \\
 &\geq \underline{3.25 \text{ A}}
 \end{aligned}$$

Peak-to-peak value:

$$\begin{aligned} \text{CH1} \\ \Delta I_L &= \frac{V_{IN(\text{Min})} - V_O}{L} \text{ ton} \\ &= \frac{15 - 3.3}{22 \times 10^{-6}} \times \frac{1}{300 \times 10^3} \times 0.22 \\ &\approx \underline{0.39 \text{ A}} \end{aligned}$$

$$\begin{aligned} \text{CH2} \\ \Delta I_L &= \frac{V_{IN(\text{Max})} - V_O}{L} \text{ ton} \\ &= \frac{15 - 5}{22 \times 10^{-6}} \times \frac{1}{300 \times 10^3} \times 0.33 \\ &\approx \underline{0.5 \text{ A}} \end{aligned}$$

• Smoothing Capacitor

The smoothing capacitor is an indispensable element for reducing ripple voltage in output. In selecting a smoothing capacitor it is essential to consider equivalent series resistance (ESR) and allowable ripple current. Higher ESR means higher ripple voltage, so that to reduce ripple voltage it is necessary to select a capacitor with low ESR. However, the use of a capacitor with low ESR can have substantial effects on loop phase characteristics, and therefore requires attention to system stability. Care should also be taken to use a capacity with sufficient margin for allowable ripple current. This application uses the 6SVP150M (OS-CON™ : SANYO) . The ESR, capacitance value, and ripple current can be calculated from the following formulas.

Equivalent Series Resistance : ESR

$$\text{ESR} \leq \frac{\Delta V_O}{\Delta I_L} - \frac{1}{2\pi f C_L}$$

Capacitance value : C_L

$$C_L \geq \frac{\Delta I_L}{2\pi f (\Delta V_O - \Delta I_L \times \text{ESR})}$$

Ripple current : $I_{C_{Lrms}}$

$$I_{C_{Lrms}} \geq \frac{(V_{IN} - V_O)}{2\sqrt{3}L} \text{ ton}$$

Example: Using the 6SVP150M

Rated voltage = 6.3 V, ESR = 35 mΩ, maximum allowable ripple current = 2.35 Arms

Equivalent series resistance

$$\begin{aligned} \text{CH1} \\ \text{ESR} &\leq \frac{\Delta V_O}{\Delta I_L} - \frac{1}{2\pi f C_L} \\ &\leq \frac{0.033}{0.39} - \frac{1}{2\pi \times 300 \times 10^3 \times 150 \times 10^{-6}} \\ &\leq \underline{81.1 \text{ m}\Omega} \end{aligned}$$

CH2

$$\begin{aligned}
 \text{ESR} &\leq \frac{\Delta V_o}{\Delta I_L} - \frac{1}{2\pi f C_L} \\
 &\leq \frac{0.05}{0.5} - \frac{1}{2\pi \times 300 \times 10^3 \times 150 \times 10^{-6}} \\
 &\leq \underline{96.5 \text{ m}\Omega}
 \end{aligned}$$

Capacitance value

CH1

$$\begin{aligned}
 C_L &\geq \frac{\Delta I_L}{2\pi f (\Delta V_o - \Delta I_L \times \text{ESR})} \\
 &\geq \frac{0.39}{2\pi \times 300 \times 10^3 \times (0.033 - 0.39 \times 0.035)} \\
 &\geq \underline{10.7 \mu\text{F}}
 \end{aligned}$$

CH2

$$\begin{aligned}
 C_L &\geq \frac{\Delta I_L}{2\pi f (\Delta V_o - \Delta I_L \times \text{ESR})} \\
 &\geq \frac{0.5}{2\pi \times 300 \times 10^3 \times (0.05 - 0.5 \times 0.035)} \\
 &\geq \underline{8.2 \mu\text{F}}
 \end{aligned}$$

Ripple current

CH1

$$\begin{aligned}
 I_{CLrms} &\geq \frac{(V_{IN (Max)} - V_o)}{2\sqrt{3}L} \text{ ton} \\
 &\geq \frac{(15 - 3.3) \times 0.22}{2\sqrt{3}L \times 22 \times 10^{-6} \times 300 \times 10^3} \\
 &\geq \underline{112.6 \text{ mArms}}
 \end{aligned}$$

CH2

$$\begin{aligned}
 I_{CLrms} &\geq \frac{(V_{IN (Max)} - V_o) \text{ ton}}{2\sqrt{3}L} \\
 &\geq \frac{(15 - 5) \times 0.33}{2\sqrt{3}L \times 22 \times 10^{-6} \times 300 \times 10^3} \\
 &\geq \underline{114.3 \text{ mArms}}
 \end{aligned}$$

REFERENCE DATA

Conversion Efficiency vs. Load Current (CH1)

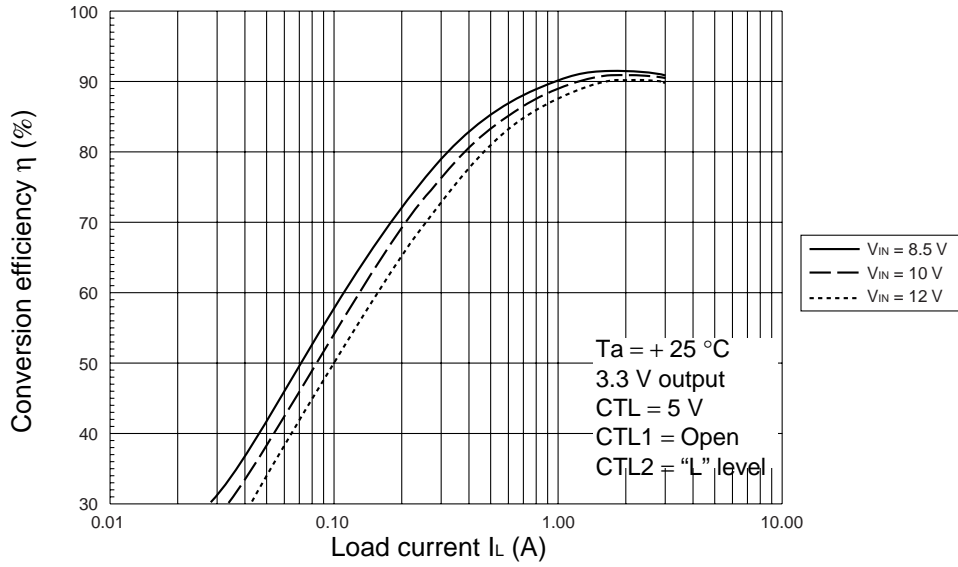

Conversion Efficiency vs. Load Current (CH2)

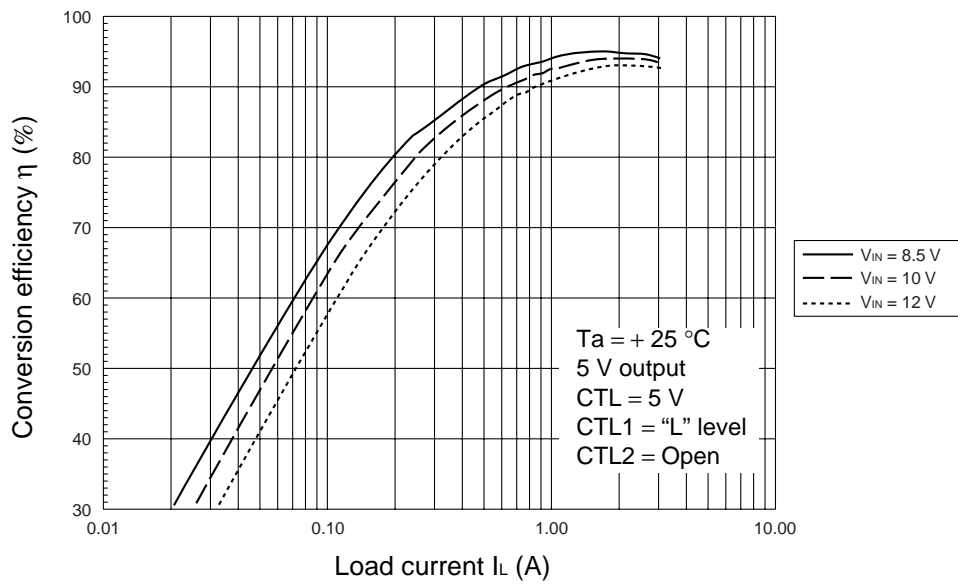

(Continued)

Switching Waveform (CH1)

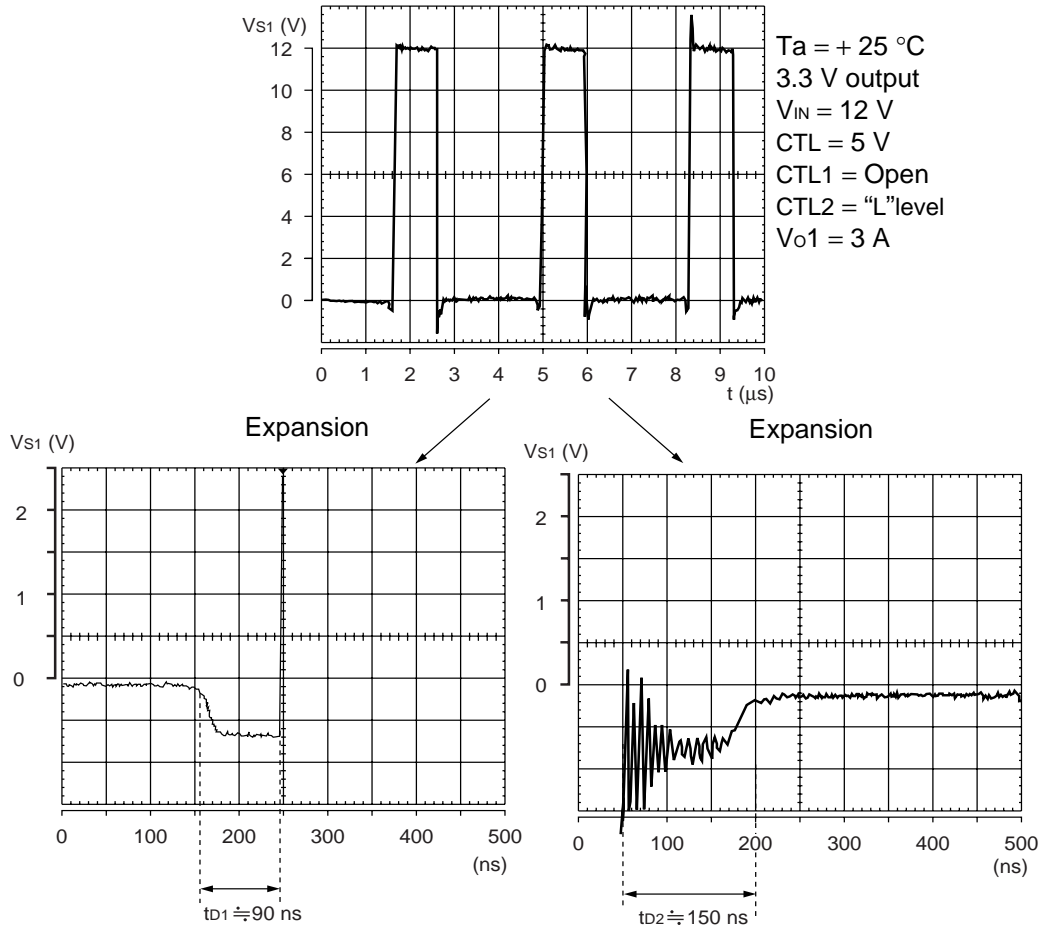

(Continued)

Switching Waveform (CH2)

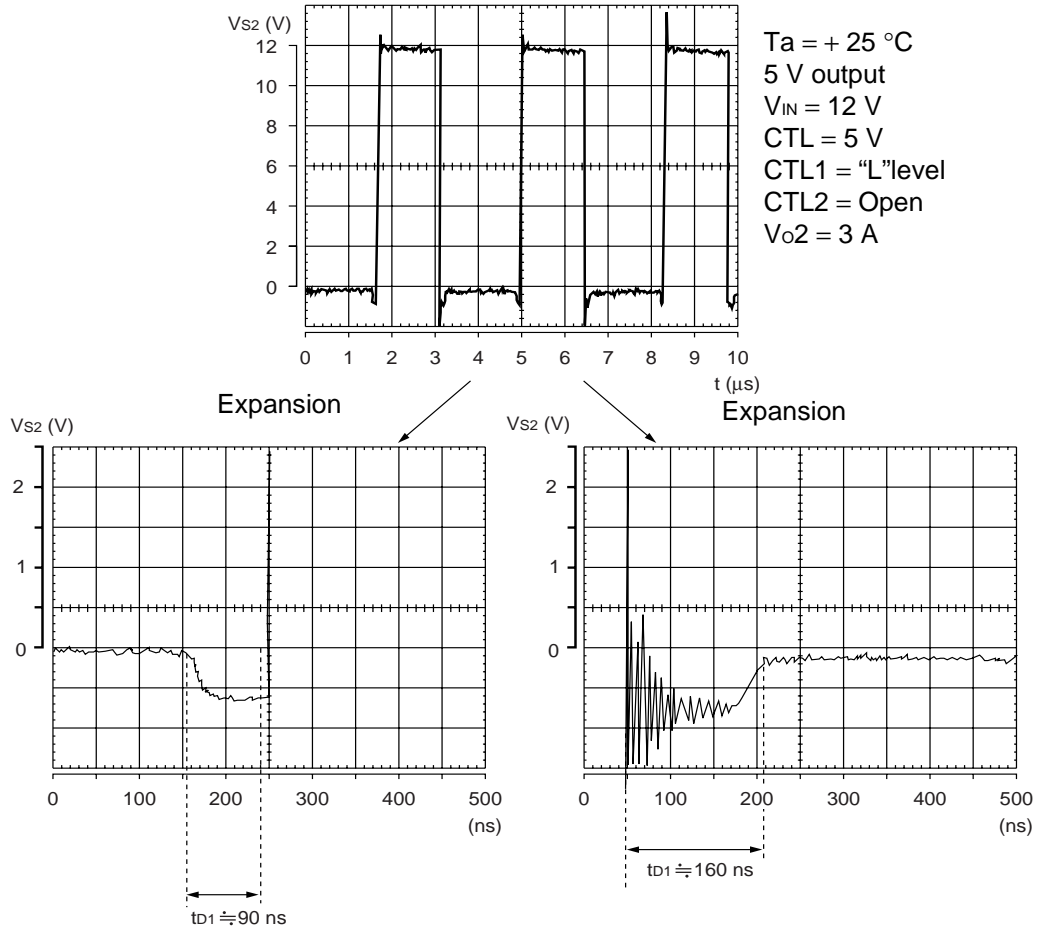

(Continued)

(Continued)

Soft-start Operating Waveform (CH1)

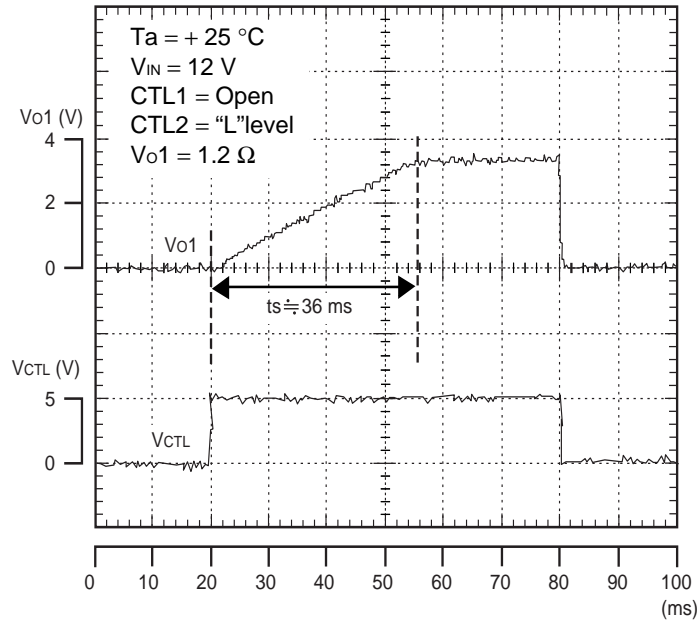

Soft-start Operating Waveform (CH2)

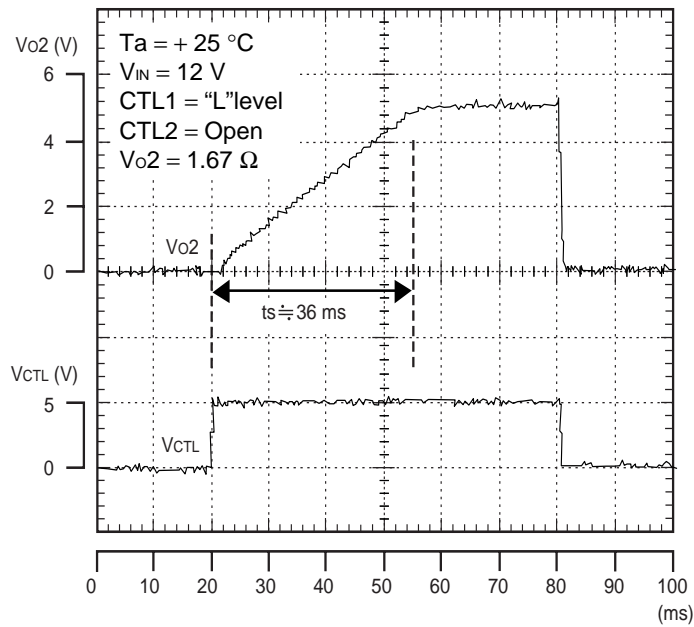

MB39A106

■ NOTES ON USE

- Take account of common impedance when designing the earth line on a printed wiring board.
- Take measures against static electricity.
 - For semiconductors, use antistatic or conductive containers.
 - When storing or carrying a printed circuit board after chip mounting, put it in a conductive bag or container.
 - The work table, tools, and measuring instruments must be grounded.
 - The worker must put on a grounding device containing 250 kΩ to 1 MΩ resistors in series.
- Do not apply a negative voltage.
 - Applying a negative voltage of -0.3 V or less to an LSI may generate a parasitic transistor, resulting in malfunction.

■ PRECAUTIONS ON HANDLING THIS PRODUCT

This product has obtained US patents for patent numbers of 6,147,477.

■ ORDERING INFORMATION

Part number	Package	Remarks
MB39A106PFT-□□□E1	30-pin plastic TSSOP (FPT-30P-M04)	Lead Free version

■ EV BOARD ORDERING INFORMATION

EV board part No.	EV board version No.	Remarks
MB39A106EVB	Board Rev. 2.0	TSSOP-30P

■ RoHS COMPLIANCE INFORMATION OF LEAD (Pb) FREE VERSION

The LSI products of Fujitsu Microelectronics with “E1” are compliant with RoHS Directive, and has observed the standard of lead, cadmium, mercury, Hexavalent chromium, polybrominated biphenyls (PBB) , and polybrominated diphenyl ethers (PBDE) .

The product that conforms to this standard is added “E1” at the end of the part number.

■ MARKING FORMAT (LEAD FREE VERSION)

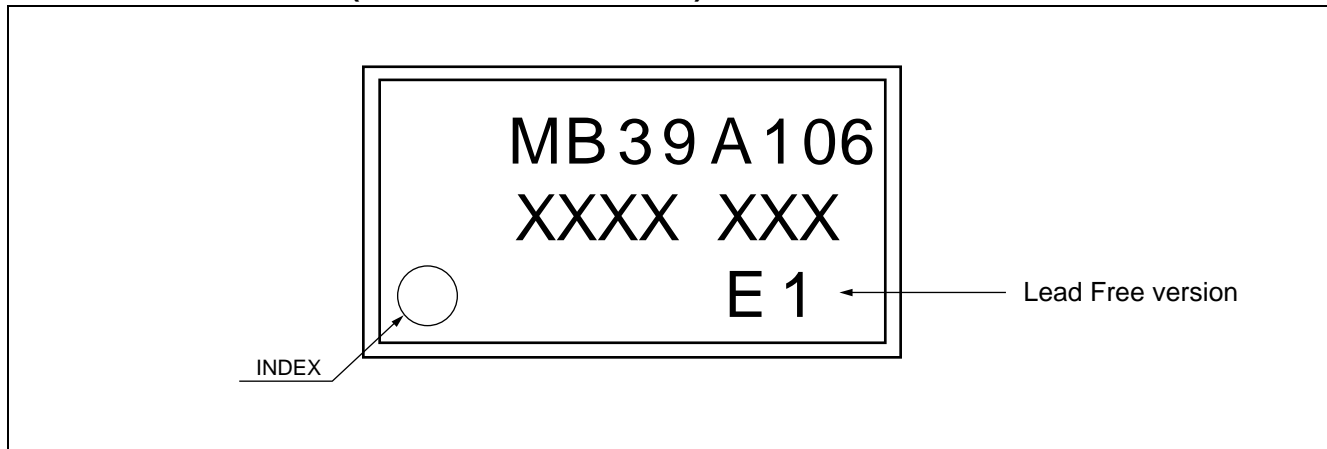

■ LABELING SAMPLE (LEAD FREE VERSION)

Lead-free mark

JEITA logo

JEDEC logo

MB123456P - 789 - GE1
(3N) 1MB123456P-789-GE1 1000

QC PASS

(3N)2 1561190005 107210

1,000 PCS

MB123456P - 789 - GE1

2006/03/01 ASSEMBLED IN JAPAN

MB123456P - 789 - GE1
1561190005 1/1 0605 - Z01A 1000

Lead Free version

The image shows a rectangular label with a dashed horizontal line. Above the line, the text 'MB123456P - 789 - GE1' is followed by '(3N) 1MB123456P-789-GE1 1000' and a barcode. Below the line, the text '2006/03/01 ASSEMBLED IN JAPAN' is followed by 'MB123456P - 789 - GE1', '1561190005', '1/1', and '0605 - Z01A 1000'. To the right of the label, there are two logos: a square with 'G' (JEITA logo) and a circle with 'Pb' (JEDEC logo). Arrows point from 'JEITA logo' to the 'G' box and from 'JEDEC logo' to the 'Pb' circle. Another arrow points from 'Lead-free mark' to the 'G' box. A third arrow points from 'Lead Free version' to the '1/1' text. The text 'QC PASS' is located between the two barcodes. The text '1,000 PCS' is located between the two barcodes. The text '(3N)2 1561190005 107210' is located between the two barcodes.

MB39A106

■ MB39A106PFT-□□□E1

RECOMMENDED CONDITIONS OF MOISTURE SENSITIVITY LEVEL

Item	Condition	
Mounting Method	IR (infrared reflow) , Manual soldering (partial heating method)	
Mounting times	2 times	
Storage period	Before opening	Please use it within two years after Manufacture.
	From opening to the 2nd reflow	Less than 8 days
	When the storage period after opening was exceeded	Please processes within 8 days after baking (125 °C, 24H)
Storage conditions	5 °C to 30 °C, 70%RH or less (the lowest possible humidity)	

[Temperature Profile for FJ Standard IR Reflow]

(1) IR (infrared reflow)

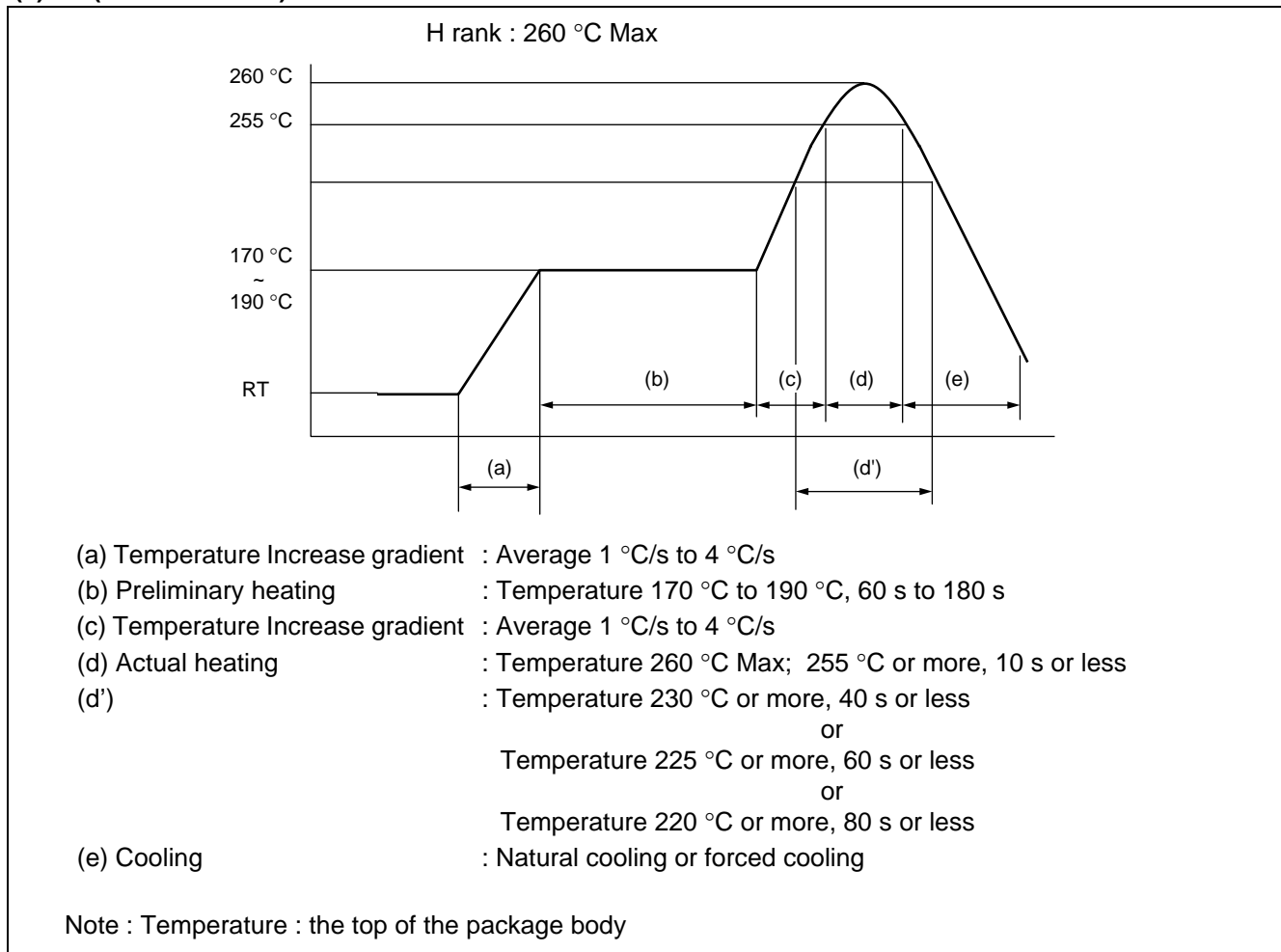

(2) Manual soldering (partial heating method)

Conditions : Temperature 400 °C Max

Times : 5 s max/pin

■ PACKAGE DIMENSION

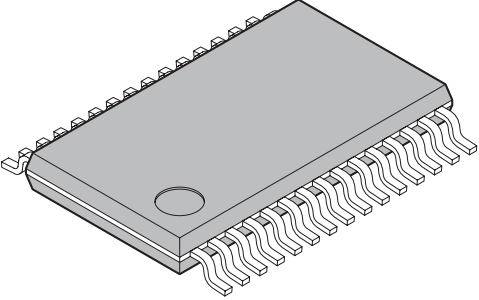
<p>30-pin plastic TSSOP</p>  <p>(FPT-30P-M04)</p>	Lead pitch	0.50 mm	
	Package width × package length	4.40 × 7.80 mm	
	Lead shape	Gullwing	
	Sealing method	Plastic mold	
	Mounting height	1.10 mm MAX	

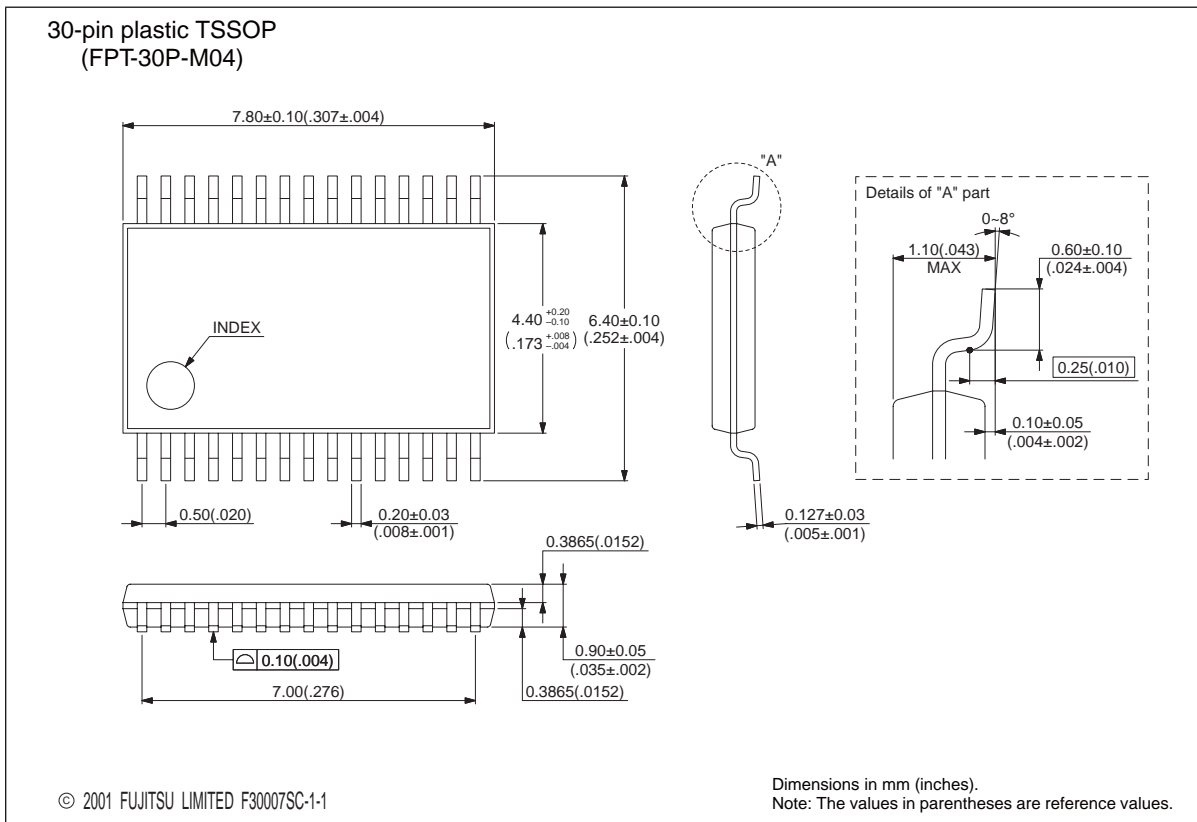

MEMO

MEMO

FUJITSU MICROELECTRONICS LIMITED

Shinjuku Dai-Ichi Seimei Bldg. 7-1, Nishishinjuku 2-chome, Shinjuku-ku,
Tokyo 163-0722, Japan Tel: +81-3-5322-3347 Fax: +81-3-5322-3387
<http://jp.fujitsu.com/fml/en/>

For further information please contact:

North and South America

FUJITSU MICROELECTRONICS AMERICA, INC.
1250 E. Arques Avenue, M/S 333
Sunnyvale, CA 94085-5401, U.S.A.
Tel: +1-408-737-5600 Fax: +1-408-737-5999
<http://www.fma.fujitsu.com/>

Europe

FUJITSU MICROELECTRONICS EUROPE GmbH
Pittlerstrasse 47, 63225 Langen,
Germany
Tel: +49-6103-690-0 Fax: +49-6103-690-122
<http://emea.fujitsu.com/microelectronics/>

Korea

FUJITSU MICROELECTRONICS KOREA LTD.
206 KOSMO TOWER, 1002 Daechi-Dong,
Kangnam-Gu, Seoul 135-280
Korea
Tel: +82-2-3484-7100 Fax: +82-2-3484-7111
<http://www.fmk.fujitsu.com/>

Asia Pacific

FUJITSU MICROELECTRONICS ASIA PTE LTD.
151 Lorong Chuan, #05-08 New Tech Park,
Singapore 556741
Tel: +65-6281-0770 Fax: +65-6281-0220
<http://www.fujitsu.com/sg/services/micro/semiconductor/>

FUJITSU MICROELECTRONICS SHANGHAI CO., LTD.
Rm.3102, Bund Center, No.222 Yan An Road(E),
Shanghai 200002, China
Tel: +86-21-6335-1560 Fax: +86-21-6335-1605
<http://cn.fujitsu.com/fmc/>

FUJITSU MICROELECTRONICS PACIFIC ASIA LTD.
10/F., World Commerce Centre, 11 Canton Road
Tsimshatsui, Kowloon
Hong Kong
Tel: +852-2377-0226 Fax: +852-2376-3269
<http://cn.fujitsu.com/fmc/tw>

All Rights Reserved.

The contents of this document are subject to change without notice.

Customers are advised to consult with sales representatives before ordering.

The information, such as descriptions of function and application circuit examples, in this document are presented solely for the purpose of reference to show examples of operations and uses of FUJITSU MICROELECTRONICS device; FUJITSU MICROELECTRONICS does not warrant proper operation of the device with respect to use based on such information. When you develop equipment incorporating the device based on such information, you must assume any responsibility arising out of such use of the information.

FUJITSU MICROELECTRONICS assumes no liability for any damages whatsoever arising out of the use of the information.

Any information in this document, including descriptions of function and schematic diagrams, shall not be construed as license of the use or exercise of any intellectual property right, such as patent right or copyright, or any other right of FUJITSU MICROELECTRONICS or any third party or does FUJITSU MICROELECTRONICS warrant non-infringement of any third-party's intellectual property right or other right by using such information. FUJITSU MICROELECTRONICS assumes no liability for any infringement of the intellectual property rights or other rights of third parties which would result from the use of information contained herein.

The products described in this document are designed, developed and manufactured as contemplated for general use, including without limitation, ordinary industrial use, general office use, personal use, and household use, but are not designed, developed and manufactured as contemplated (1) for use accompanying fatal risks or dangers that, unless extremely high safety is secured, could have a serious effect to the public, and could lead directly to death, personal injury, severe physical damage or other loss (i.e., nuclear reaction control in nuclear facility, aircraft flight control, air traffic control, mass transport control, medical life support system, missile launch control in weapon system), or (2) for use requiring extremely high reliability (i.e., submersible repeater and artificial satellite).

Please note that FUJITSU MICROELECTRONICS will not be liable against you and/or any third party for any claims or damages arising in connection with above-mentioned uses of the products.

Any semiconductor devices have an inherent chance of failure. You must protect against injury, damage or loss from such failures by incorporating safety design measures into your facility and equipment such as redundancy, fire protection, and prevention of over-current levels and other abnormal operating conditions.

Exportation/release of any products described in this document may require necessary procedures in accordance with the regulations of the Foreign Exchange and Foreign Trade Control Law of Japan and/or US export control laws.

The company names and brand names herein are the trademarks or registered trademarks of their respective owners.