

# ASSP For Power Management Applications (DC/DC Converter for DSC/Camcorder)

## 4-ch DC/DC Converter IC for low voltage

# MB39A103

### ■ DESCRIPTION

The MB39A103 is a 4-channel DC/DC converter IC using pulse width modulation (PWM). This IC is ideal for up conversion, down conversion, and up/down conversion.

Achievement of low voltage start-up (1.7 V or more) enables operation from low voltage.

4ch is built in TSSOP-30P/package. Each channel can be controlled, and soft-start.

This is an ideal power supply for high-performance portable devices such as digital still cameras.

This product is covered by US Patent Number 6,147,477.

### ■ FEATURES

- Supports for down-conversion and up/down Zeta conversion (CH1)
- Supports for up-conversion and up/down Sepic conversion (CH2 to CH4)
- Low voltage start-up (CH4): 1.7 V
- Power supply voltage range : 2.5 V to 11 V
- Reference voltage :  $2.0 \text{ V} \pm 1 \%$
- Error amplifier threshold voltage :  $1.24 \text{ V} \pm 1.5 \%$
- Built-in totem-pole type output for MOS FET
- Built-in soft-start circuit independent of loads
- High-frequency operation capability: 1.5 MHz (Max)
- External short-circuit detection capability by -INS terminal

### ■ PACKAGES

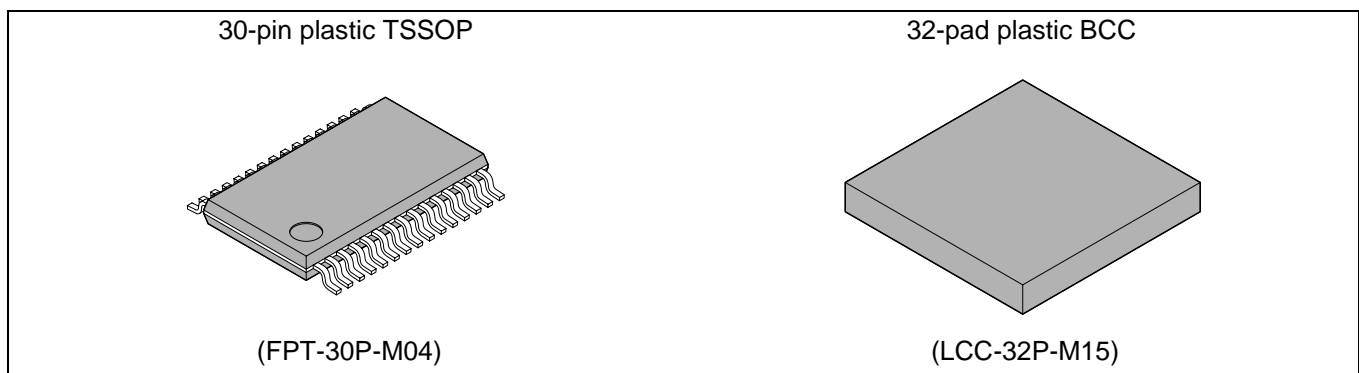

# MB39A103

## ■ PIN ASSIGNMENTS

(TOP VIEW)

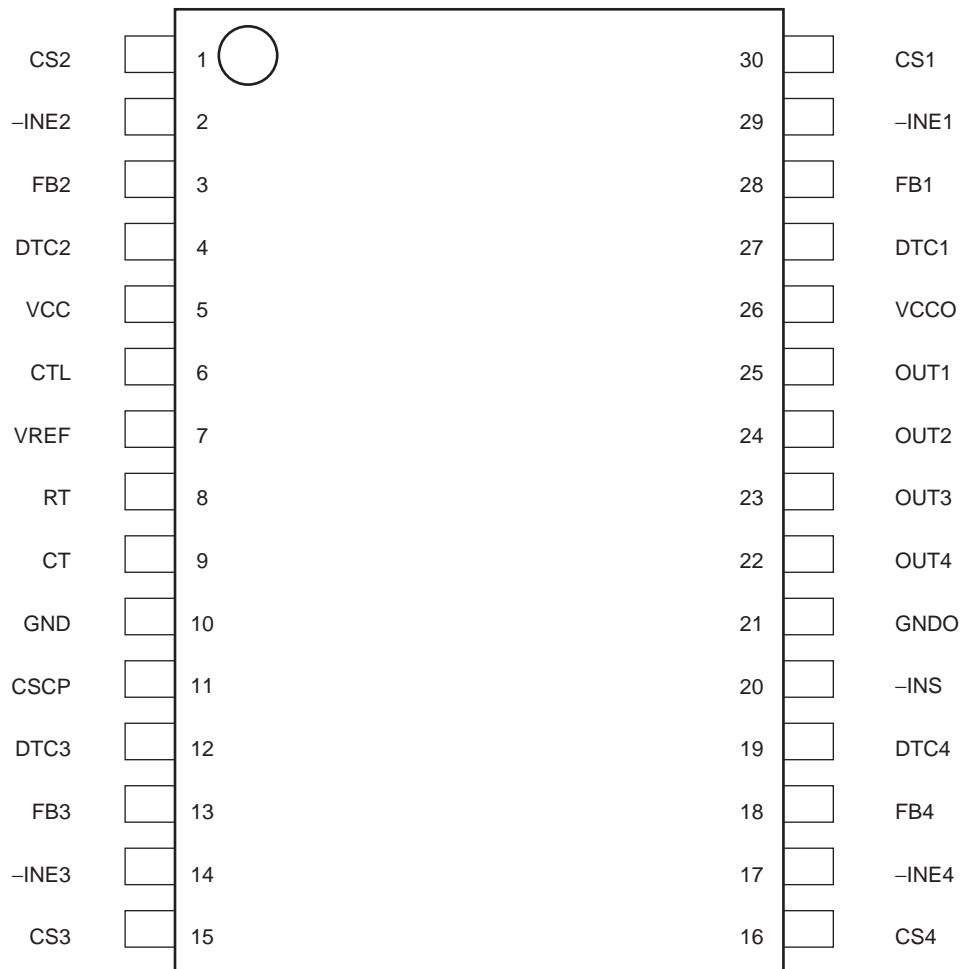

(FPT-30P-M04)

(Continued)

(Continued)

(TOP VIEW)  
(Penetration diagram from surface)

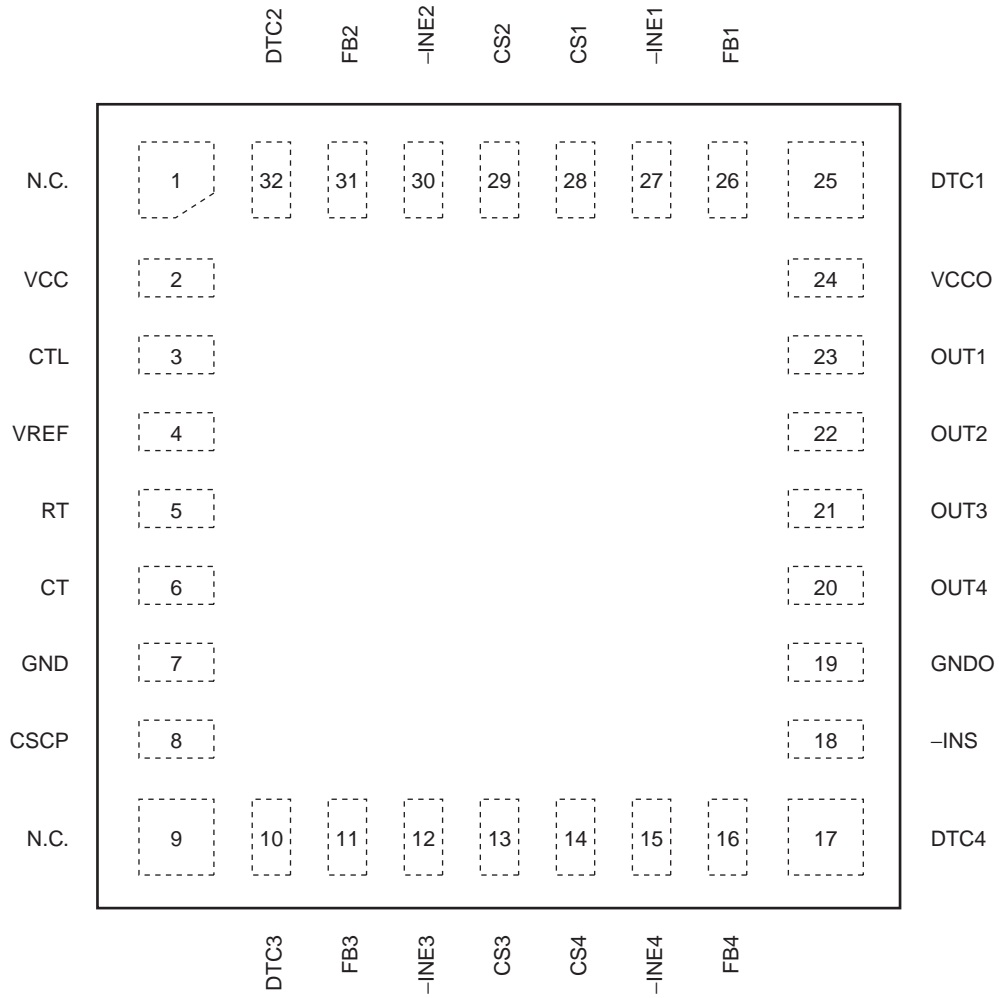

(LCC-32P-M15)

# MB39A103

## ■ PIN DESCRIPTION

Block	Pin No.		Symbol	I/O	Descriptions
	TSSOP	BCC			
CH1	27	25	DTC1	I	Dead time control terminal
	28	26	FB1	O	Error amplifier output terminal
	29	27	-INE1	I	Error amplifier inverted input terminal
	30	28	CS1	—	Soft-start setting capacitor connection terminal
	25	23	OUT1	O	Totem pole type output terminal
CH2	4	32	DTC2	I	Dead time control terminal
	3	31	FB2	O	Error amplifier output terminal
	2	30	-INE2	I	Error amplifier inverted input terminal
	1	29	CS2	—	Soft-start setting capacitor connection terminal
	24	22	OUT2	O	Totem pole type output terminal
CH3	12	10	DTC3	I	Dead time control terminal
	13	11	FB3	O	Error amplifier output terminal
	14	12	-INE3	I	Error amplifier inverted input terminal
	15	13	CS3	—	Soft-start setting capacitor connection terminal
	23	21	OUT3	O	Totem pole type output terminal
CH4	19	17	DTC4	I	Dead time control terminal
	18	16	FB4	O	Error amplifier output terminal
	17	15	-INE4	I	Error amplifier inverted input terminal
	16	14	CS4	—	Soft-start setting capacitor connection terminal
	22	20	OUT4	O	Totem pole type output terminal
OSC	9	6	CT	—	Triangular wave frequency setting capacitor connection terminal
	8	5	RT	—	Triangular wave frequency setting resistor connection terminal
Control	6	3	CTL	I	Power supply control terminal
	11	8	CSCP	—	Short-circuit detection circuit capacitor connection terminal
	20	18	-INS	I	Short-circuit detection comparator inverted input terminal
Power	26	24	VCCO	—	Output block power supply terminal
	5	2	VCC	—	Power supply terminal
	7	4	VREF	O	Reference voltage output terminal
	21	19	GNDO	—	Output block ground terminal
	10	7	GND	—	Ground terminal

## ■ BLOCK DIAGRAM

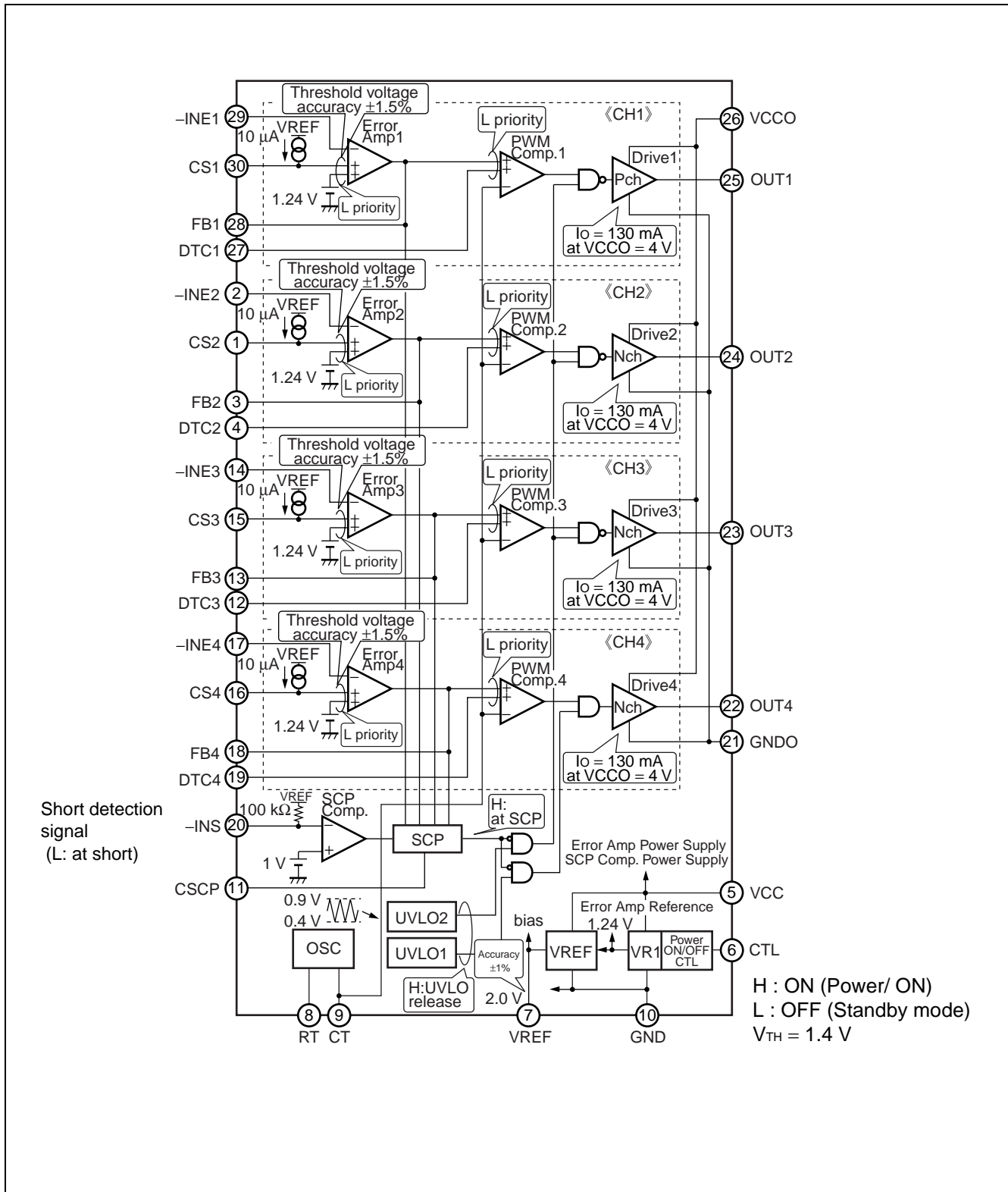

# MB39A103

## ■ ABSOLUTE MAXIMUM RATINGS

Parameter	Symbol	Condition	Rating		Unit
			Min	Max	
Power supply voltage	V <sub>CC</sub>	VCC, VCCO terminals	—	12	V
Output current	I <sub>O</sub>	OUT1 to OUT4 terminals	—	20	mA
Peak output current	I <sub>OP</sub>	OUT1 to OUT4 terminals Duty ≤ 5% (t = 1/f <sub>OSC</sub> × Duty)	—	400	mA
Power dissipation	P <sub>D</sub>	T <sub>A</sub> ≤ +25 °C (TSSOP-30P)	—	1390*	mW
		T <sub>A</sub> ≤ +25 °C (BCC-32P)	—	980*	mW
Storage temperature	T <sub>STG</sub>	—	-55	+125	°C

\* : The packages are mounted on the epoxy board (10 cm × 10 cm).

WARNING: Semiconductor devices can be permanently damaged by application of stress (voltage, current, temperature, etc.) in excess of absolute maximum ratings. Do not exceed these ratings.

## ■ RECOMMENDED OPERATING CONDITIONS

Parameter	Symbol	Condition	Value			Unit
			Min	Typ	Max	
Start power supply voltage	V <sub>CC</sub>	VCC, VCCO terminals (CH4)	1.7	—	11	V
Power supply voltage	V <sub>CC</sub>	VCC, VCCO terminal s (CH1 to CH4)	2.5	4	11	V
Reference voltage output current	I <sub>REF</sub>	VREF terminal	-1	—	0	mA
Input voltage	V <sub>INE</sub>	-INE1 to -INE4 terminals	0	—	V <sub>CC</sub> - 0.9	V
		-INS terminal	0	—	V <sub>REF</sub>	V
	V <sub>DTC</sub>	DTC1 to DTC4 terminals	0	—	V <sub>REF</sub>	V
Control input voltage	V <sub>CTL</sub>	CTL terminal	0	—	11	V
Output current	I <sub>O</sub>	OUT1 to OUT4 terminals	-15	—	+15	mA
Oscillation frequency	f <sub>OSC</sub>	*	100	500	1500	kHz
Timing capacitor	C <sub>T</sub>	—	39	100	560	pF
Timing resistor	R <sub>T</sub>	—	11	24	130	kΩ
Soft-start capacitor	C <sub>S</sub>	CS1 to CS4 terminals	—	0.1	1.0	μF
Short-circuit detection capacitor	C <sub>SCP</sub>	—	—	0.1	1.0	μF
Reference voltage output capacitor	C <sub>REF</sub>	—	—	0.1	1.0	μF
Operating ambient temperature	T <sub>A</sub>	—	-30	+25	+85	°C

\* : See “■ SETTING THE TRIANGULAR OSCILLATION FREQUENCY”.

Note: Pin numbers referred after this part are present on TSSOP-30P PKG.

WARNING: The recommended operating conditions are required in order to ensure the normal operation of the semiconductor device. All of the device's electrical characteristics are warranted when the device is operated within these ranges.

Always use semiconductor devices within their recommended operating condition ranges. Operation outside these ranges may adversely affect reliability and could result in device failure.

No warranty is made with respect to uses, operating conditions, or combinations not represented on the data sheet. Users considering application outside the listed conditions are advised to contact their representatives beforehand.

## ■ ELECTRICAL CHARACTERISTICS

(VCC = VCCO = 4 V, T<sub>A</sub> = +25 °C)

Parameter	Symbol	Pin No	Conditions	Value			Unit	
				Min	Typ	Max		
Reference voltage block [Ref]	Output voltage	V <sub>REF</sub>	7	—	1.98	2.00	2.02	V
	Output voltage temperature stability	$\Delta V_{REF} / V_{REF}$	7	T <sub>A</sub> = -30 °C to +85 °C	—	0.5*	—	%
	Input stability	Line	7	VCC = 2.5 V to 11 V	-10	—	+10	mV
	Load stability	Load	7	VREF = 0 mA to -1 mA	-10	—	+10	mV
Under voltage lockout protection circuit block (CH4) [UVLO1]	Threshold voltage	V <sub>TH</sub>	22	VCC = $\underline{\text{L}}$	1.4	1.5	1.65	V
	Hysteresis width	V <sub>H</sub>	22	—	0.02	0.05	0.1	V
Under voltage lockout protection circuit block (CH1 to CH3) [UVLO2]	Threshold voltage	V <sub>TH</sub>	25	VCC = $\underline{\text{L}}$	1.7	1.8	1.95	V
	Hysteresis width	V <sub>H</sub>	25	—	0.05	0.1	0.2	V
Short-circuit detection block [SCP]	Threshold voltage	V <sub>TH</sub>	11	—	0.65	0.70	0.75	V
	Input source current	I <sub>SCCP</sub>	11	—	-1.4	-1.0	-0.6	μA
	Reset voltage	V <sub>RST</sub>	25	VREF = $\underline{\text{L}}$	1.3	1.45	1.63	V
Triangular wave oscillator block [OSC]	Oscillation frequency	f <sub>OSC</sub>	22, 23, 24, 25	CT = 100 pF, RT = 24 kΩ	450	500	550	kHz
	Frequency temperature stability	$\Delta f_{OSC} / f_{OSC}$	22, 23, 24, 25	T <sub>A</sub> = -30 °C to +85 °C	—	1*	—	%
Soft-start block [CS1 to CS4]	Charge current	I <sub>CS</sub>	1, 15, 16, 30	CS1 to CS4 = 0 V	-14	-10	-6	μA
Error amplifier block [Error Amp1 to Error Amp4]	Threshold voltage	V <sub>TH</sub>	3, 13, 18, 28	FB1 to FB4 = 0.65 V	1.222	1.240	1.258	V
	Input bias current	I <sub>B</sub>	2, 14, 17, 29	-INE1 to -INE4 = 0 V	-120	-30	—	nA
	Voltage gain	A <sub>V</sub>	3, 13, 18, 28	DC	—	100*	—	dB
	Frequency bandwidth	BW	3, 13, 18, 28	A <sub>V</sub> = 0 dB	—	1.6*	—	MHz

\* : Standard design value

(Continued)

# MB39A103

(Continued)

(VCC = VCCO = 4 V, T<sub>A</sub> = +25 °C)

Parameter	Symbol	Pin No	Conditions	Value			Unit	
				Min	Typ	Max		
Error amplifier block [Error Amp1 to Error Amp4]	Output voltage	V <sub>OH</sub>	3, 13, 18, 28	—	1.7	1.9	—	V
		V <sub>OL</sub>	3, 13, 18, 28	—	—	40	200	mV
	Output source current	I <sub>SOURCE</sub>	3, 13, 18, 28	FB1 to FB4 = 0.65 V	—	-2	-1	mA
	Output sink current	I <sub>SINK</sub>	3, 13, 18, 28	FB1 to FB4 = 0.65 V	150	200	—	μA
PWM comparator block [PWM Comp.1 to PWM Comp.4]	Threshold voltage	V <sub>T0</sub>	22, 23, 24, 25	Duty cycle = 0 %	0.3	0.4	—	V
		V <sub>T100</sub>	22, 23, 24, 25	Duty cycle = Dtr	—	0.9	1.0	V
	Input current	I <sub>DTC</sub>	4, 12, 19, 27	DTC1 to DTC4 = 0.4 V	-2.0	-0.6	—	μA
Output block [Drive1 to Drive4]	Output source current	I <sub>SOURCE</sub>	22, 23, 24, 25	Duty ≤ 5 % (t = 1/f <sub>osc</sub> × Duty) OUT1 to OUT4 = 0 V	—	-130	-75	mA
	Output sink current	I <sub>SINK</sub>	22, 23, 24, 25	Duty ≤ 5 % (t = 1/f <sub>osc</sub> × Duty) OUT1 to OUT4 = 4 V	75	130	—	mA
	Output ON resistor	R <sub>OH</sub>	22, 23, 24, 25	OUT1 to OUT4 = -15 mA	—	18	27	Ω
		R <sub>OL</sub>	22, 23, 24, 25	OUT1 to OUT4 = 15 mA	—	18	27	Ω
Short-circuit detection comparator block [SCP Comp.]	Threshold voltage	V <sub>TH</sub>	25	—	0.97	1.00	1.03	V
	Input bias current	I <sub>B</sub>	20	-INS = 0 V	-25	-20	-17	μA
Control block [CTL]	CTL input voltage	V <sub>IH</sub>	6	IC Active mode	1.7	—	11	V
		V <sub>IL</sub>	6	IC Standby mode	0	—	0.8	V
	Input current	I <sub>CTLH</sub>	6	CTL = 3 V	5	30	60	μA
		I <sub>CTL</sub>	6	CTL = 0 V	—	—	1	μA
General	Standby current	I <sub>CCS</sub>	5	CTL = 0 V	—	0	2	μA
		I <sub>CCSO</sub>	26	CTL = 0 V	—	0	2	μA
	Power supply current	I <sub>CC</sub>	5	CTL = 3 V	—	2.3	4.5	mA

\*: Standard design value.

## ■ TYPICAL CHARACTERISTICS

Power Supply Current vs. Power Supply Voltage

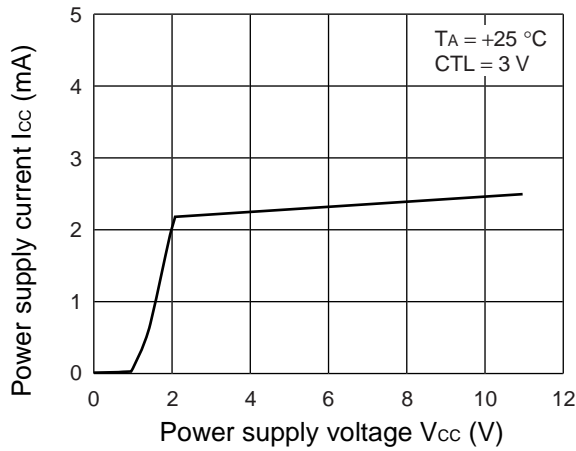

Reference Voltage vs. Power Supply Voltage

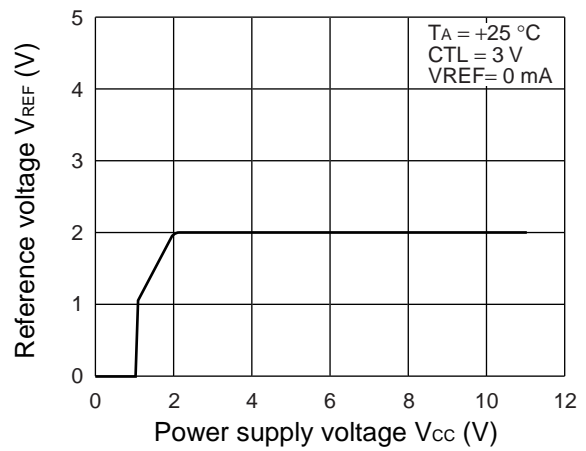

Reference Voltage vs. Operating Ambient Temperature

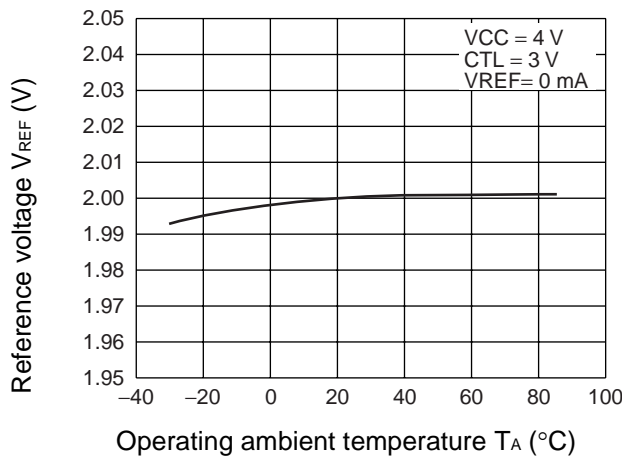

Reference Voltage vs. CTL terminal Voltage

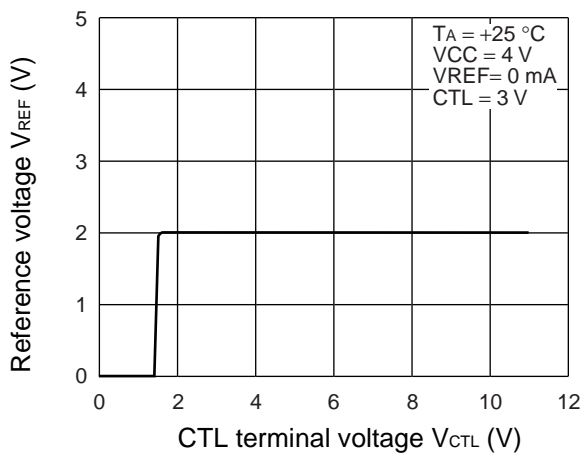

CTL terminal Current vs. CTL terminal Voltage

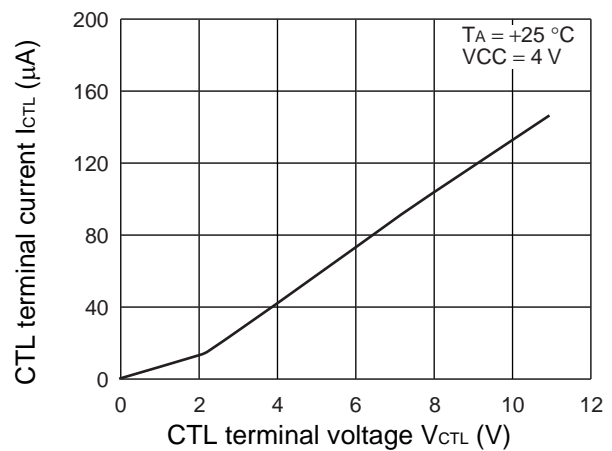

(Continued)

Triangular Wave Oscillation Frequency vs. Timing Resistor

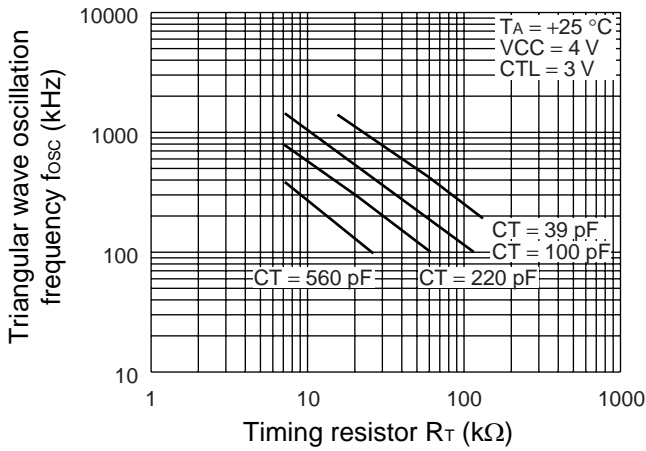

Triangular Wave Oscillation Frequency vs. Timing Capacitor

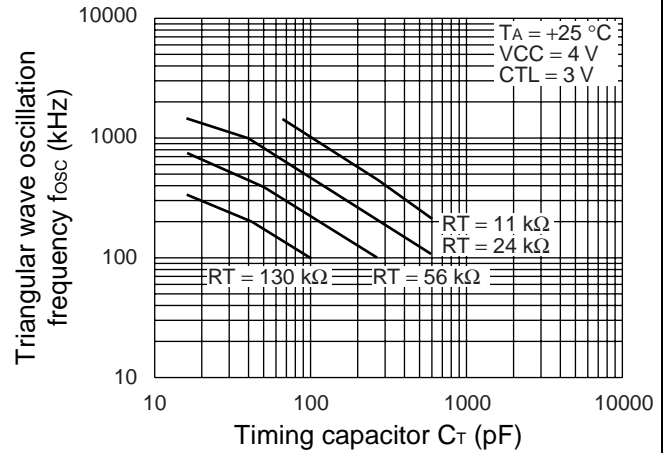

Triangular Wave Upper and Lower Limit Voltage vs. Triangular Wave Oscillation Frequency

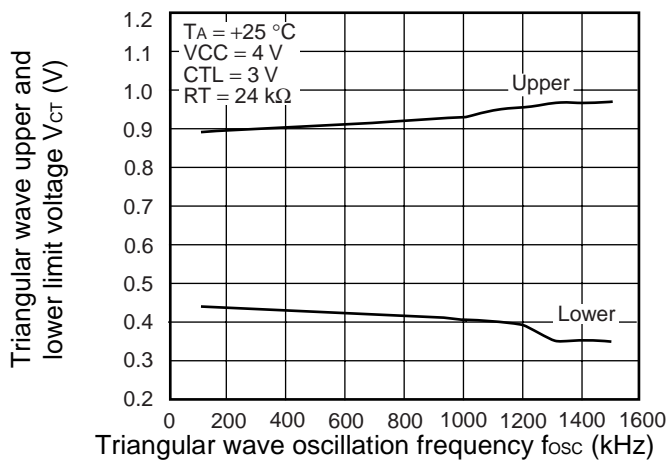

Triangular Wave Upper and Lower Limit Voltage vs. Operating Ambient Temperature

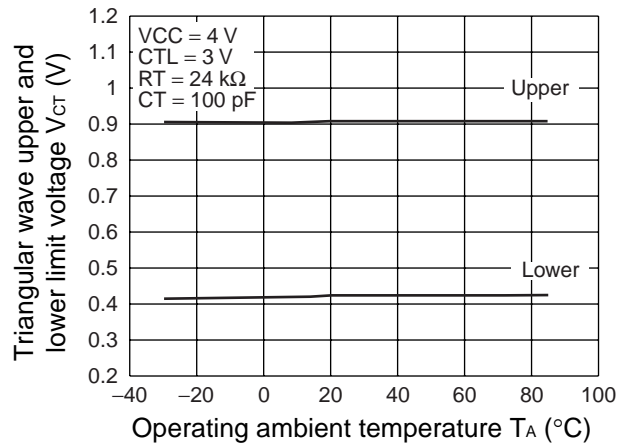

Triangular Wave Oscillation Frequency vs. Operating Ambient Temperature

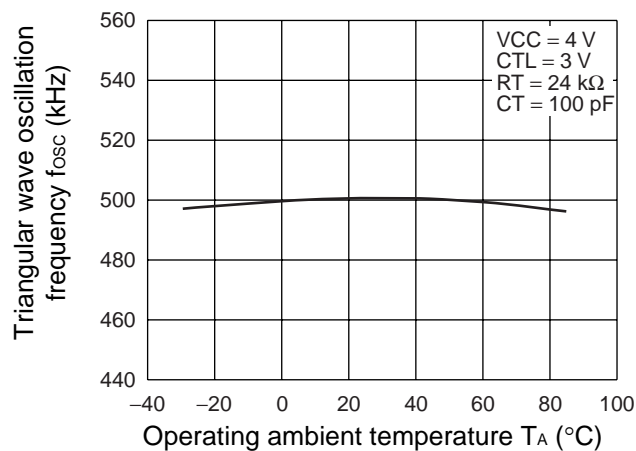

(Continued)

(Continued)

Error Amplifier Voltage Gain, Phase vs. Frequency

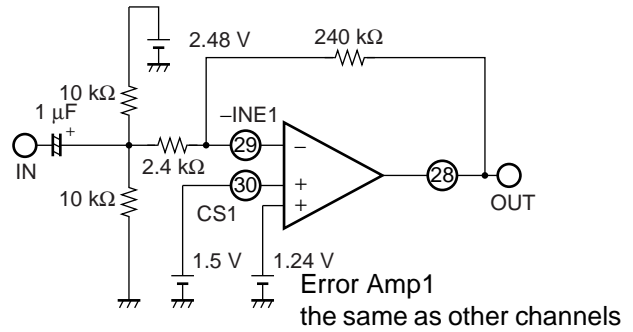
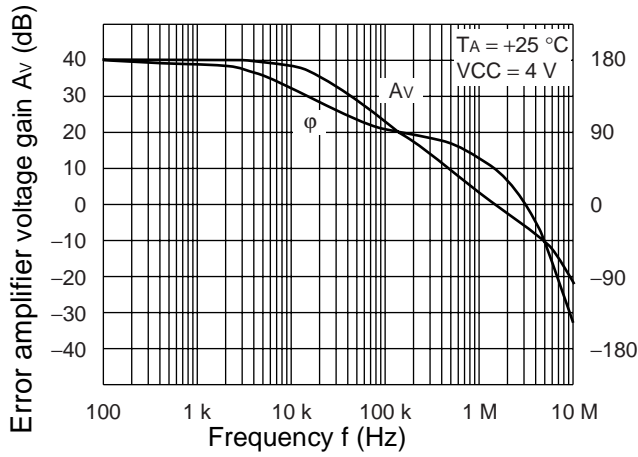

Power Dissipation vs. Operating Ambient Temperature (TSSOP-30P)

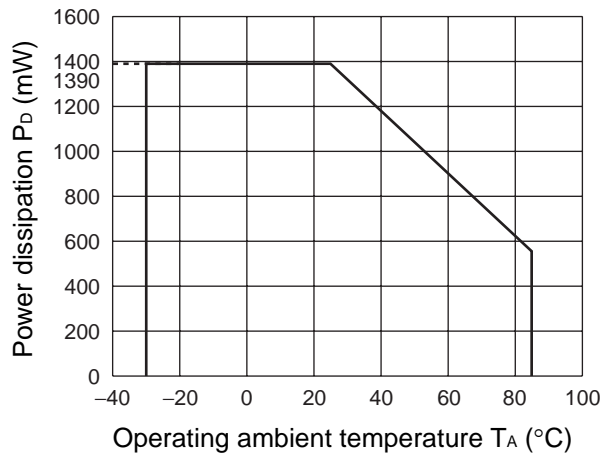

Power Dissipation vs. Operating Ambient Temperature (BCC-32P)

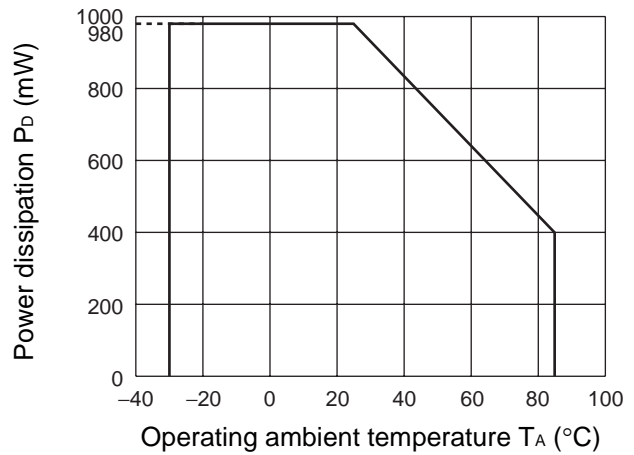

## ■ FUNCTIONS

### 1. DC/DC Converter Functions

#### (1) Reference voltage block (Ref)

The reference voltage circuit generates a temperature-compensated reference voltage (2.0 V Typ) from the voltage supplied from the VCC terminal (pin 5). The voltage is used as the reference voltage for the IC's internal circuitry.

The reference voltage can supply a load current of up to 1 mA to an external device through the VREF terminal (pin 7).

#### (2) Triangular-wave oscillator block (OSC)

The triangular wave oscillator incorporates a timing capacitor and a timing resistor connected respectively to the CT terminal (pin 9) and RT terminal (pin 8) to generate triangular oscillation waveform amplitude of 0.4 V to 0.9 V.

The triangular waveforms are input to the PWM comparator in the IC.

#### (3) Error amplifier block (Error Amp1 to Error Amp4)

The error amplifier detects the DC/DC converter output voltage and outputs PWM control signals. In addition, an arbitrary loop gain can be set by connecting a feedback resistor and capacitor from the output terminal to inverted input terminal of the error amplifier, enabling stable phase compensation to the system.

Also, it is possible to prevent rush current at power supply start-up by connecting a soft-start capacitor with the CS1 terminal (pin 30) to CS4 terminal (pin 16) which are the non-inverted input terminal for Error Amp. The use of Error Amp for soft-start detection makes it possible for a system to operate on a fixed soft-start time that is independent of the output load on the DC/DC converter.

#### (4) PWM comparator block (PWM Comp.1 to PWM Comp.4)

The PWM comparator is a voltage-to-pulse width modulator that controls the output duty depending on the input/output voltage.

The output transistor turns on while the error amplifier output voltage and DTC voltage remain higher than the triangular wave voltage.

#### (5) Output block (Drive1 to Drive4)

The output block is in the totem pole type, capable of driving an external P-channel MOS FET (channel 1), and N-channel MOS FET (channels 2 to 4).

## 2. Channel Control Function

The main or each channel is turned on and off depending on the voltage levels at the CTL terminal (pin 6), CS1 terminal (pin 30), CS2 terminal (pin 1), CS3 terminal (pin 15), and CS4 terminal (pin 16).

Channel On/Off Setting Conditions

CTL	CS1	CS2	CS3	CS4	Power	CH1	CH2	CH3	CH4
L	—*	—*	—*	—*	OFF	OFF	OFF	OFF	OFF
H	GND	GND	GND	GND	ON	OFF	OFF	OFF	OFF
H	High-Z	GND	GND	GND	ON	ON	OFF	OFF	OFF
H	GND	High-Z	GND	GND	ON	OFF	ON	OFF	OFF
H	GND	GND	High-Z	GND	ON	OFF	OFF	ON	OFF
H	GND	GND	GND	High-Z	ON	OFF	OFF	OFF	ON
H	High-Z	High-Z	High-Z	High-Z	ON	ON	ON	ON	ON

\*: Undefined

## 3. Protective Functions

### (1) Timer-latch short-circuit protection circuit (SCP, SCP Comp.)

The short-circuit detection comparator detects the Error Amp output voltage level of each channel, and if any channel output voltage of Error Amp reaches the short-circuit detection voltage, the timer circuits are actuated to start charging the external capacitor  $C_{SCP}$  connected to the CSCP terminal (pin 11).

When the capacitor ( $C_{SCP}$ ) voltage reaches about 0.7 V, the circuit is turned off the output transistor and sets the dead time to 100 %.

In addition, the short-circuit detection from external input is capable by using  $-INS$  terminal (pin 20) on short-circuit detection comparator (SCP Comp.) .

To release the actuated protection circuit, either the power supply turn off and on again or set the CTL terminal (pin 6) to the "L" level to lower the VREF terminal (pin 7) voltage to 1.3 V (Min) or less. (See "■SETTING TIME CONSTANT FOR TIMER-LATCH SHORT-CIRCUIT PROTECTION CIRCUIT".)

### (2) Under voltage lockout protection circuit (UVLO)

The transient state or a momentary decrease in supply voltage, which occurs when the power supply is turned on, may cause the IC to malfunction, resulting in breakdown or degradation of the system. To prevent such malfunctions, under voltage lockout protection circuit detects a decrease in internal reference voltage with respect to the power supply voltage, turns off the output transistor, and sets the dead time to 100% while holding the CSCP terminal (pin 11) at the "L" level.

The circuit restores the output transistor to normal when the supply voltage reaches the threshold voltage of the undervoltage lockout protection circuit.

## ■ PROTECTION CIRCUIT OPERATING FUNCTION TABLE

This table refers to output condition when protection circuit is operating.

Operating circuit	OUT1	OUT2	OUT3	OUT4
Short-circuit protection circuit	H	L	L	L
Under voltage lockout protection circuit	H	L	L	L

## ■ SETTING THE OUTPUT VOLTAGE

• CH1 to CH4

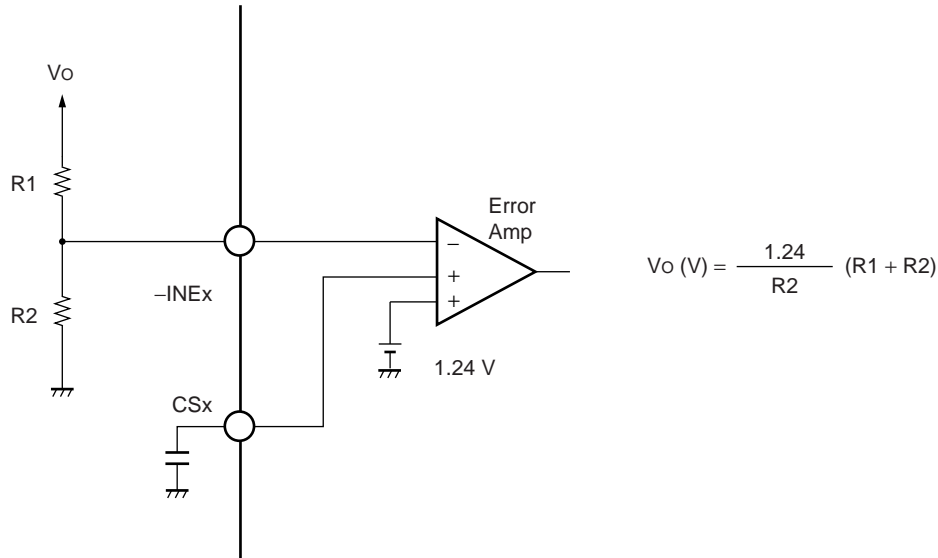

$$V_o (V) = \frac{1.24}{R_2} (R_1 + R_2)$$

x: Each channel No.

## ■ SETTING THE TRIANGULAR OSCILLATION FREQUENCY

The triangular oscillation frequency is determined by the timing capacitor ( $C_T$ ) connected to the CT terminal (pin 9), and the timing resistor ( $R_T$ ) connected to the RT terminal (pin 8).

Moreover, it shifts more greatly than the calculated values according to the constant of timing resistor ( $R_T$ ) when the triangular wave oscillation frequency exceeds 1 MHz. Therefore, set it referring to “Triangular Wave Oscillation Frequency vs. Timing Resistor” and “Triangular Wave Oscillation Frequency vs. Timing Capacitor” in “■ TYPICAL CHARACTERISTICS”.

Triangular oscillation frequency :  $f_{osc}$

$$f_{osc} \text{ (kHz)} \doteq \frac{1200000}{C_T \text{ (pF)} \bullet R_T \text{ (k}\Omega\text{)}}$$

## ■ SETTING THE SOFT-START TIME

To prevent rush currents when the IC is turned on, you can set a soft-start by connecting soft-start capacitors ( $C_{S1}$  to  $C_{S4}$ ) to the CS1 terminal (pin 30) to the CS4 terminal (pin 16), respectively.

Setting each  $\overline{CTLx}$  from "H" to "L" switches to charge the external soft-start capacitors ( $C_{S1}$  to  $C_{S4}$ ) connected to the CS1 terminal (pin 30) to CS4 terminal (pin 16) at  $10 \mu\text{A}$ .

The error amplifier output (FB1 to FB4) is determined by comparison between the lower one of the potentials at two non-inverted input terminals ( $1.24 \text{ V}$ , CS terminal voltages) and the inverted input terminal voltage ( $-\text{INE1}$  to  $-\text{INE4}$ ).

The FB terminal voltage during the soft-start period (CS terminal voltage  $< 1.24 \text{ V}$ ) is therefore determined by comparison between the  $-\text{INE}$  terminal and CS terminal voltages. The DC/DC converter output voltage rises in proportion to the CS terminal voltage as the soft-start capacitor connected to the CS terminal is charged.

The soft-start time is obtained from the following formula:

Soft-start time:  $t_s$  (time to output 100%)

$$t_s (\text{s}) \approx 0.124 \times C_{Sx} (\mu\text{F})$$

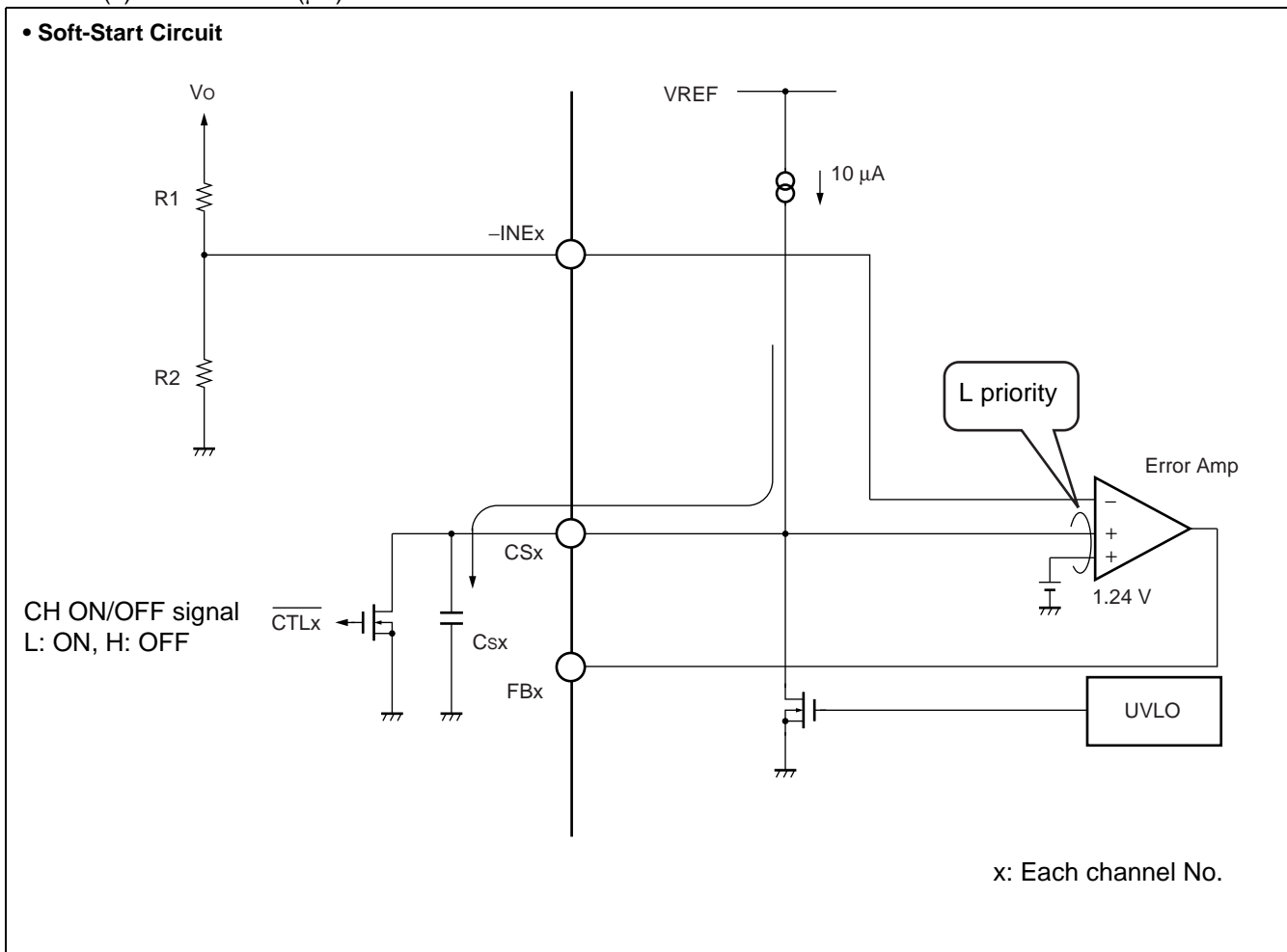

## ■ TREATMENT WITHOUT USING CS TERMINAL

When not using the soft-start function, open the CS1 terminal (pin 30), the CS2 terminal (pin 1), the CS3 terminal (pin 15), the CS4 terminal (pin 16).

### • Without Setting Soft-Start Time

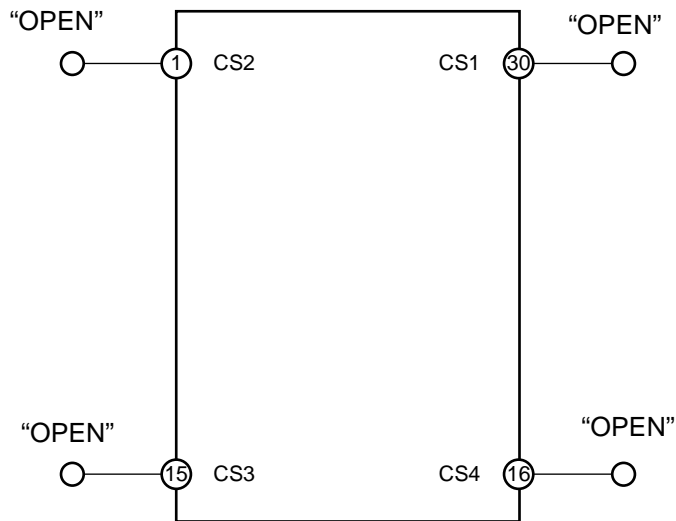

## ■ SETTING TIME CONSTANT FOR TIMER-LATCH SHORT-CIRCUIT PROTECTION CIRCUIT

Each channel uses the short-circuit detection comparator (SCP) to always compare the error amplifier's output level to the reference voltage.

While DC/DC converter load conditions are stable on all channels, the short-circuit detection comparator output remains at "L" level, and the CSCP terminal (pin 11) is held at "L" level.

If the load condition on a channel changes rapidly due to a short-circuit of the load, causing the output voltage to drop, the output of the short-circuit detection comparator on that channel goes to "H" level. This causes the external short-circuit protection capacitor  $C_{SCP}$  connected to the CSCP terminal (pin 11) to be charged at  $1 \mu\text{A}$ .

Short-circuit detection time :  $t_{SCP}$

$$t_{SCP} (\text{s}) \approx 0.70 \times C_{SCP} (\mu\text{F})$$

When the capacitor  $C_{SCP}$  is charged to the threshold voltage ( $V_{TH} \approx 0.70 \text{ V}$ ), the latch is set and the external FET is turned off (dead time is set to 100%). At this time, the latch input is closed and the CSCP terminal (pin 11) is held at "L" level.

In addition, the short-circuit detection from external input is capable by using  $-\text{INS}$  terminal (pin 20) on the short-circuit detection comparator (SCP Comp.). The short-circuit detection operation starts when  $-\text{INS}$  terminal voltage is less than threshold voltage ( $V_{TH} \approx 1 \text{ V}$ ).

When the power supply is turn off and on again or  $V_{REF}$  terminal (pin 7) voltage is less than 1.3 V (Min) by setting CTL terminal (pin 6) to "L" level, the latch is released.

### • Timer-latch short-circuit protection circuit

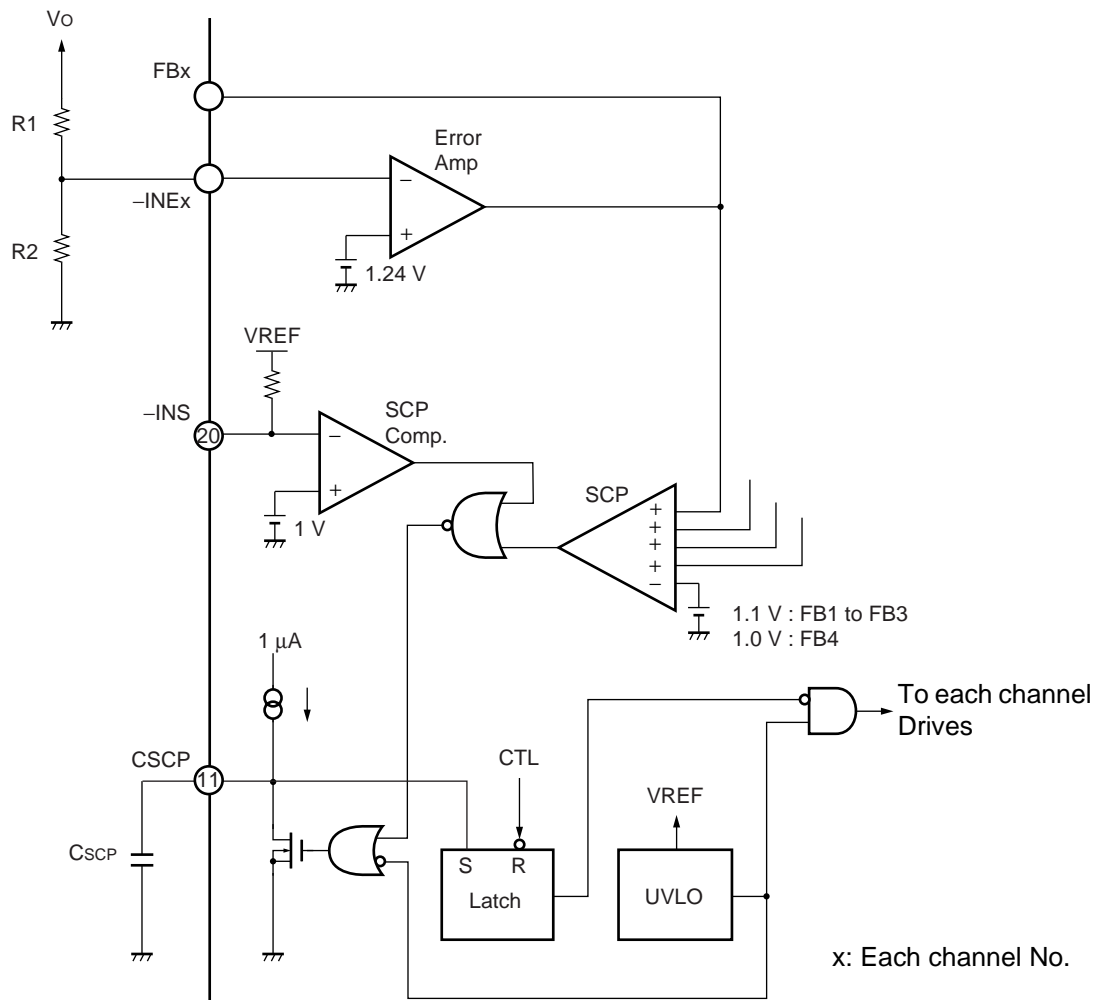

Note : When using self-power supply configuration in which the output from the CH4 DC/DC converter is connected to the VCC, note that short-circuit detection is not possible in the CH4 DC/DC converter output.

## ■ TREATMENT WITHOUT USING CSCP TERMINAL

When not using the timer-latch short-circuit protection circuit, connect the CSCP terminal (pin 11) to GND (pin 10) with the shortest distance.

- Treatment without using CSCP terminal

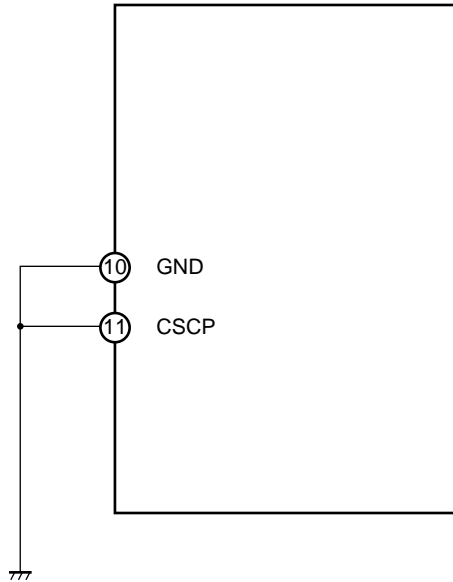

## ■ SETTING THE DEAD TIME

When the device is set for step-up or inverted output based on the step-up or step-up/down Zeta conversion, step-up/down Sepic conversion or flyback conversion, the FB terminal voltage may reach and exceed the triangular wave voltage due to load fluctuation. If this is the case, the output transistor is fixed to a full-ON state (ON duty = 100 %). To prevent this, set the maximum duty of the output transistor. To set it, set the voltage at the DTC terminal by applying a resistive voltage divider to the VREF voltage as shown below.

When the DTC terminal voltage is higher than the triangular wave voltage, the output transistor is turned on. The maximum duty calculation formula assuming that triangular wave amplitude = 0.5 V and triangular wave lower voltage = 0.4 V is given below.

$$\text{DUTY (ON) Max} \approx \frac{V_{dt} - 0.4 \text{ V}}{0.5 \text{ V}} \times 100 (\%), \quad V_{dt} (\text{V}) = \frac{R_b}{R_a + R_b} \times V_{REF}$$

When the DTC terminal is not used, connect it directly to the VREF terminal (pin 7) as shown below (when no dead time is set).

### • When using DTC to set dead time

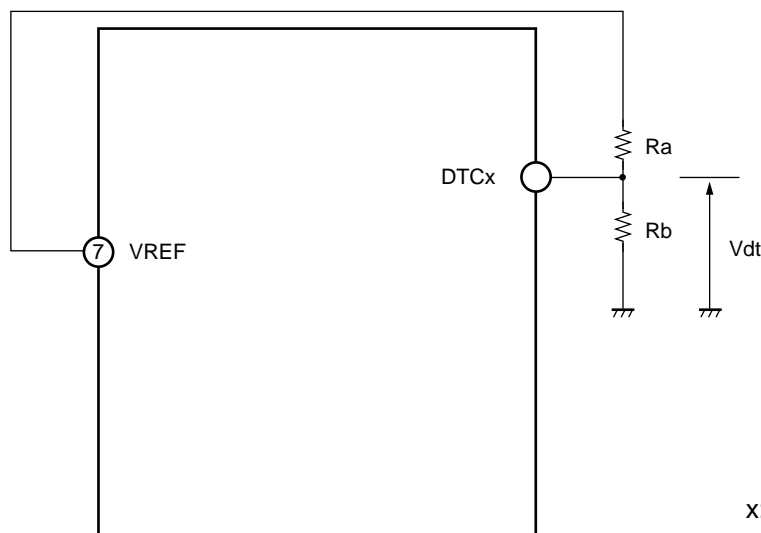

### • When no dead time is set

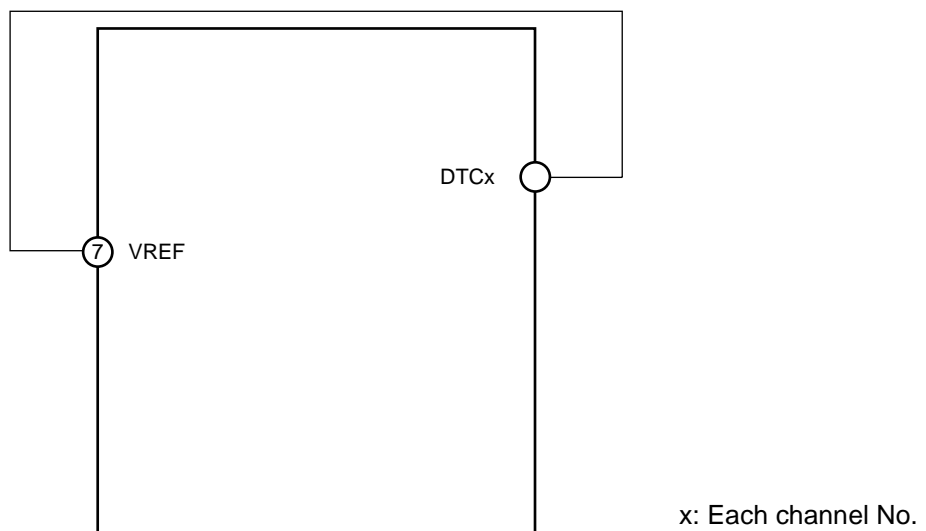

## ■ POWERR SUPPLY EXAMPLE USING CH4 FOR SELF-POWER SUPPLY

The MB39A103 can be started with the low input voltage ( $V_{IN} \geq 1.7\text{ V}$ ) if the CH4 is used as a self-power supply. An example of supply the power using the transformer is shown below.

### • Power supply example using CH4 for self-power supply

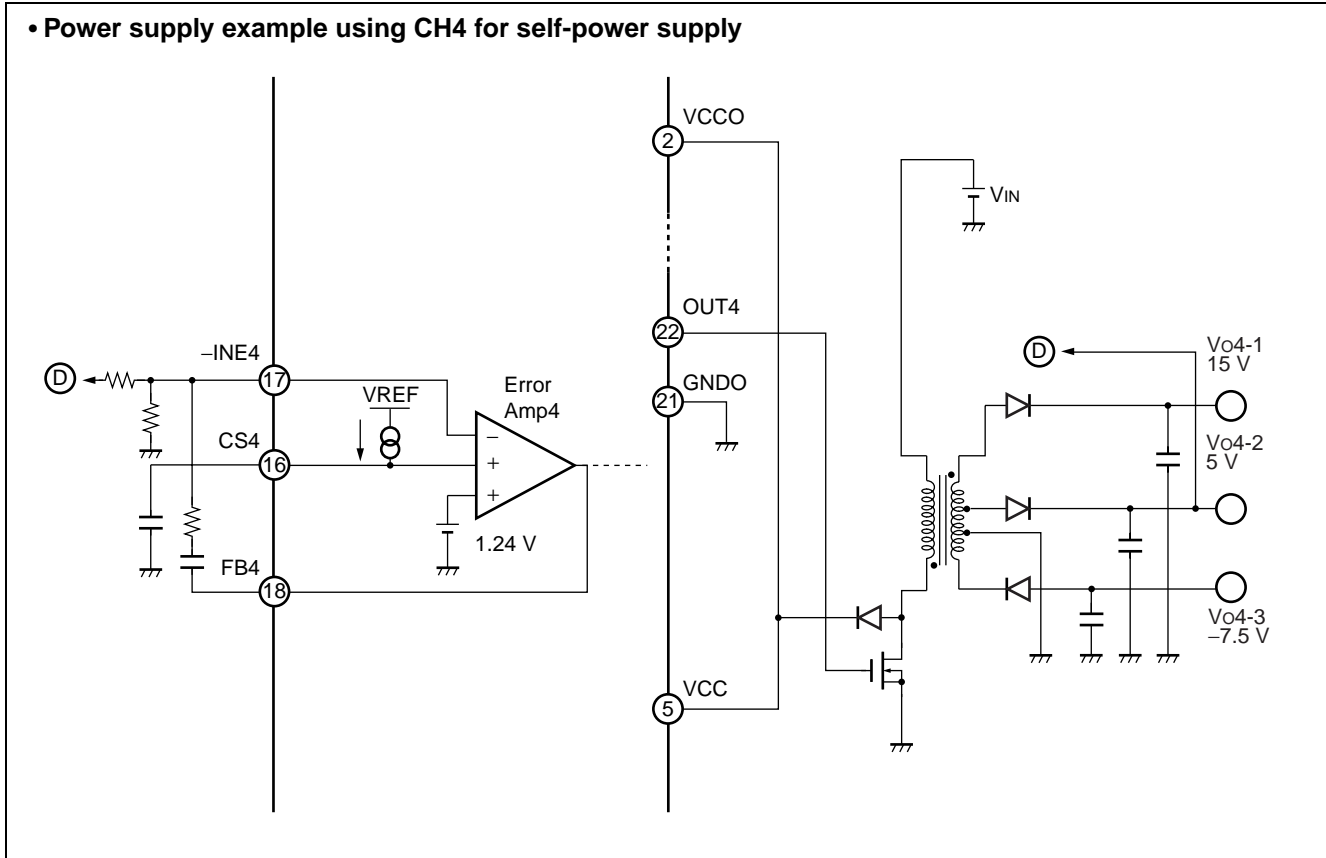

Setting shown in the “■ APPLICATION EXAMPLE” is as follows:

- Number of windings for VCC and VCCO is set to the value equivalent to  $V_{IN} + 2.5\text{ V}$ .

CH1 to CH3 are operational on  $V_{CC} \geq 2.5\text{ V}$ ; in order for the CH1 to CH3 to operate on  $V_{IN} \geq 1.7\text{ V}$ , the number of windings should be set equivalent to  $V_{IN} + 0.8\text{ V}$  or more for VCC and VCCO.



• Timing Chart

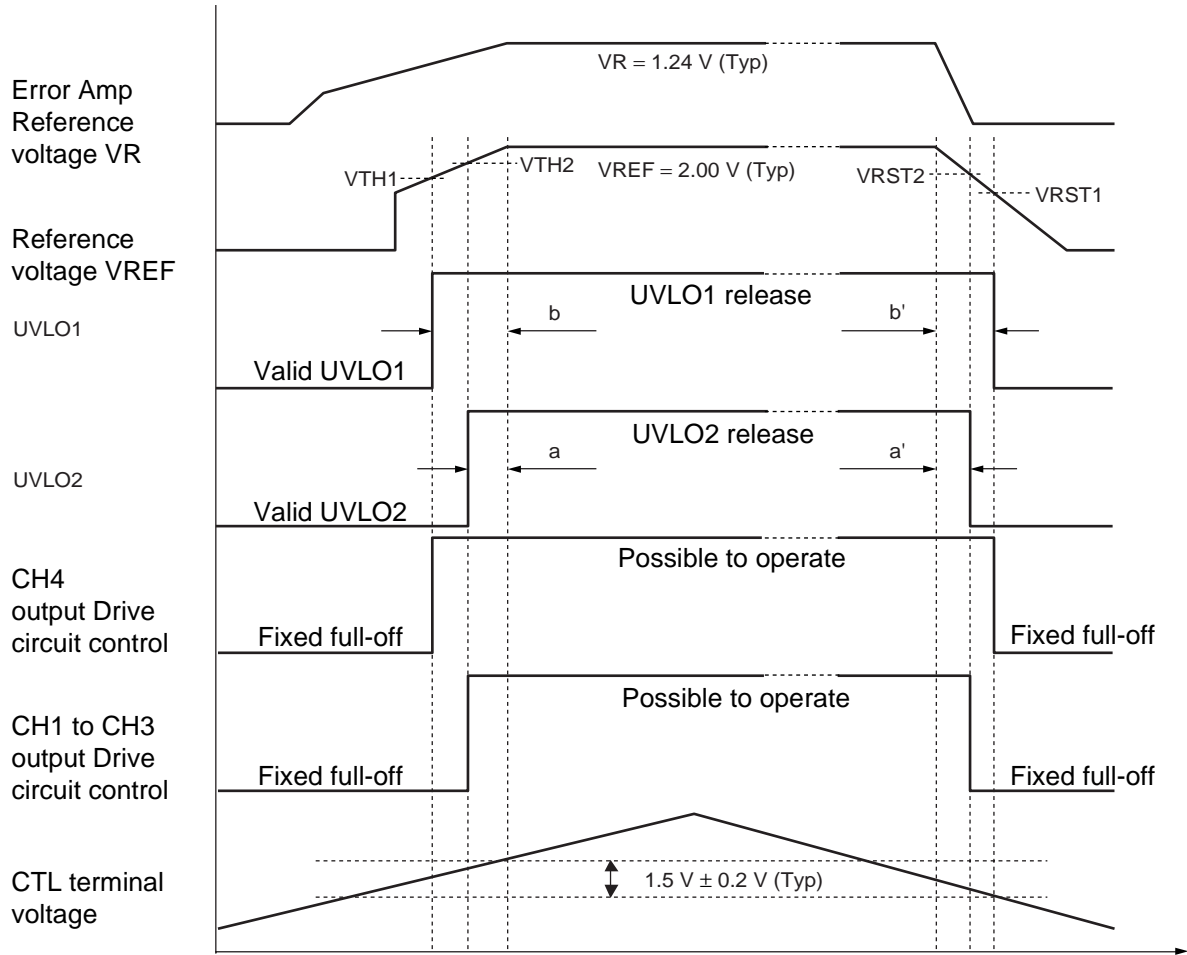

## I/O EQUIVALENT CIRCUIT

«Reference voltage block»

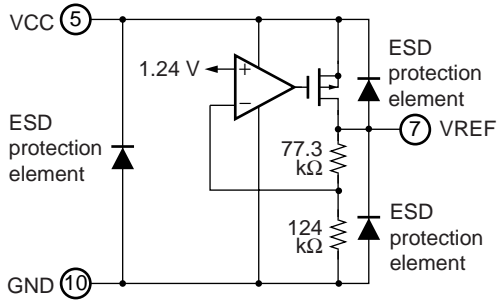

«Control block»

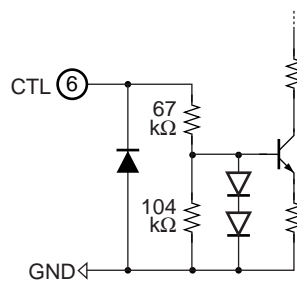

«Soft-start block»

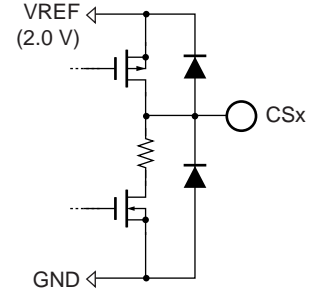

«Short-circuit detection block»

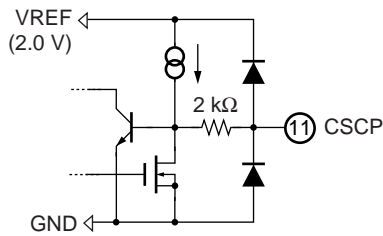

«Triangular wave oscillator block (RT)»

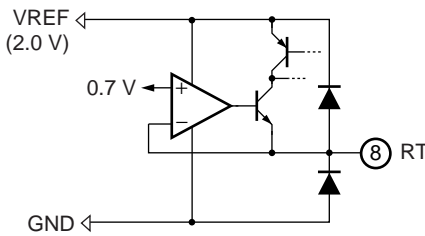

«Triangular wave oscillator block (CT)»

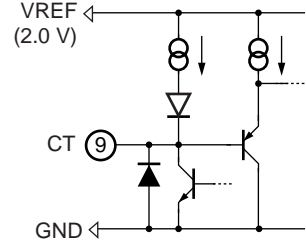

«Error amplifier block (CH1 to CH4)»

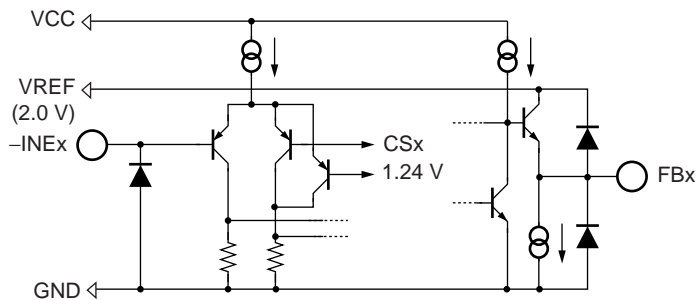

«Short-circuit detection comparator block»

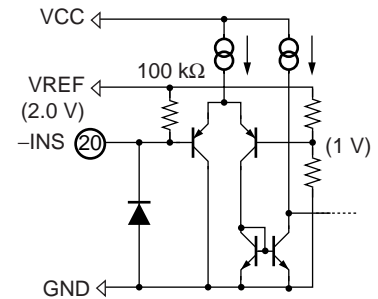

«PWM comparator block (CH1 to CH4)»

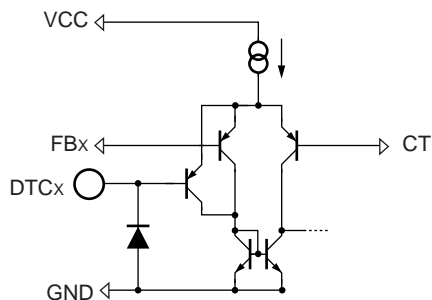

«Output block (CH1 to CH4)»

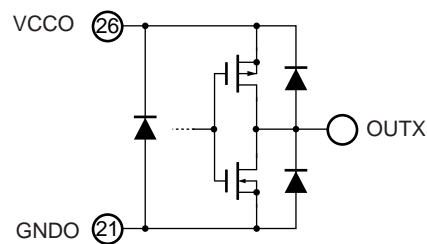

x: Each channel No.

# MB39A103

## APPLICATION EXAMPLE

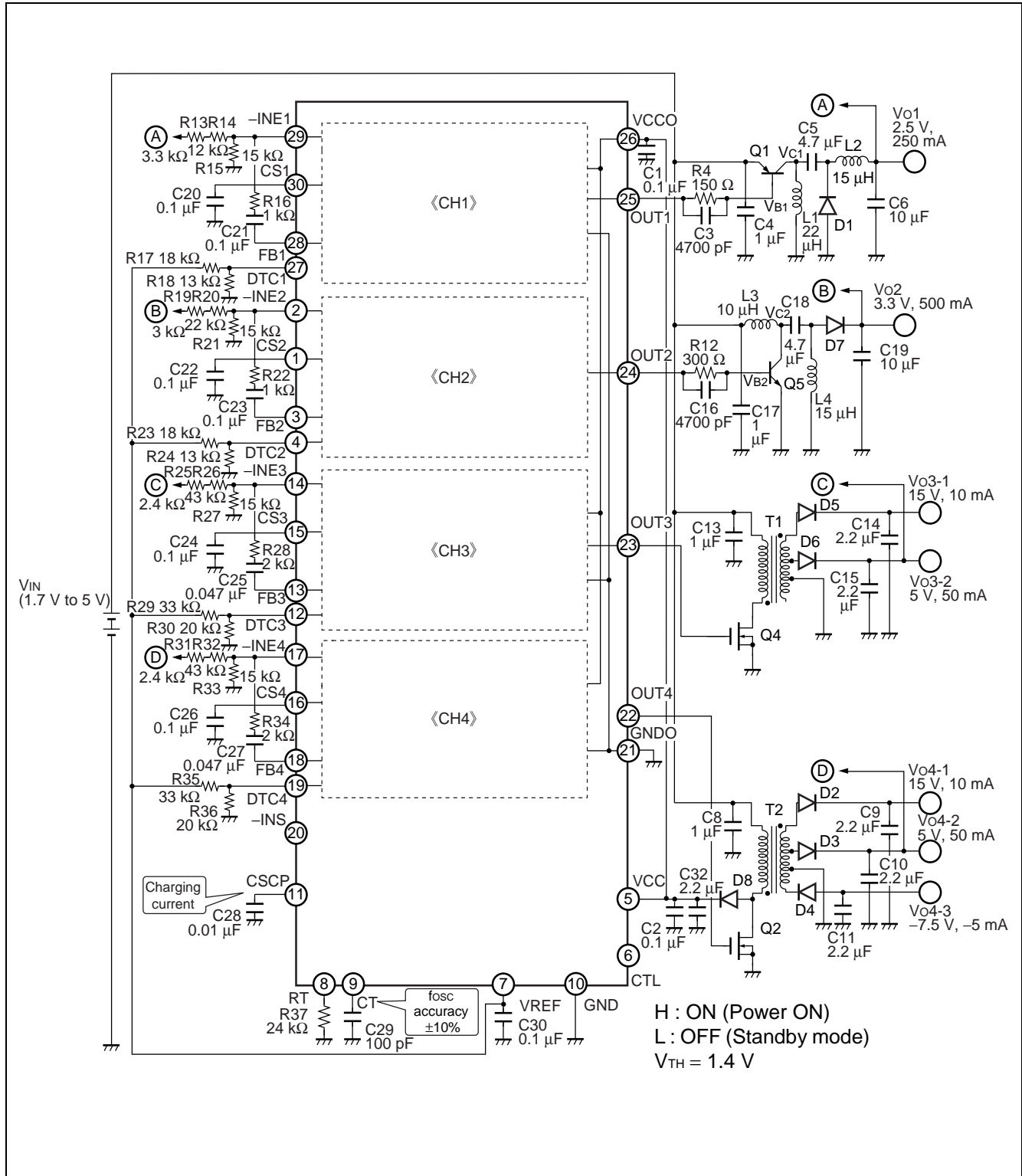



## ■ REFERENCE DATA

### TOTAL Efficiency vs. Input Voltage

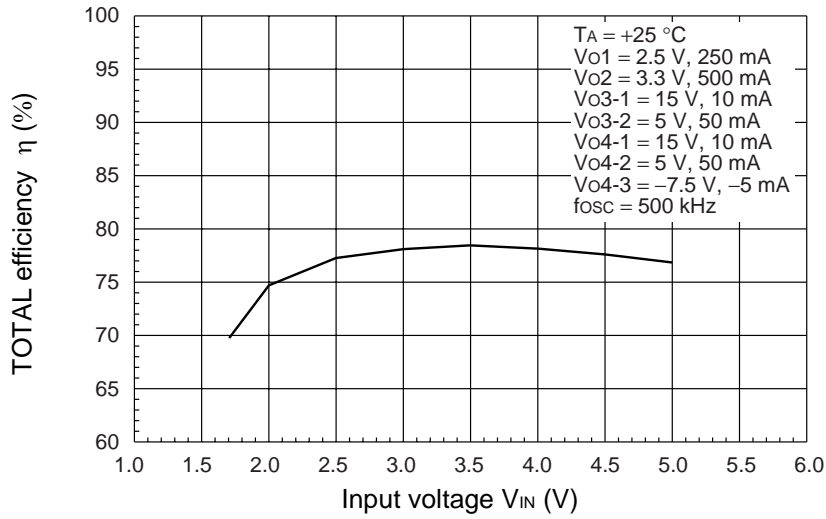

### Each CH Efficiency vs. Input Voltage

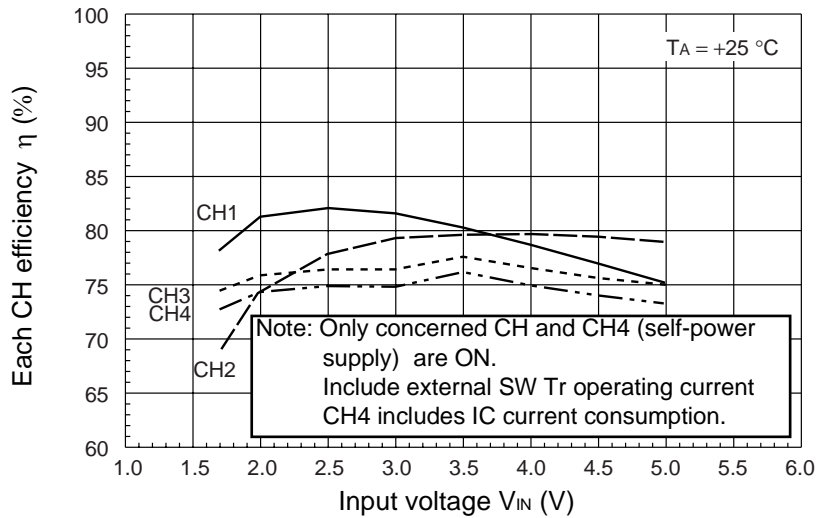

(Continued)

### Conversion Efficiency vs. Load Current (CH1)

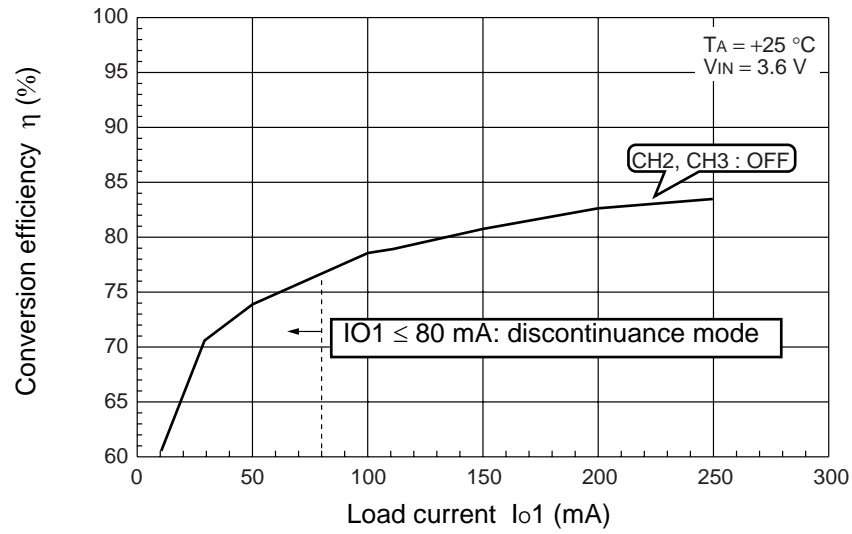

### Conversion Efficiency vs. Load Current (CH2)

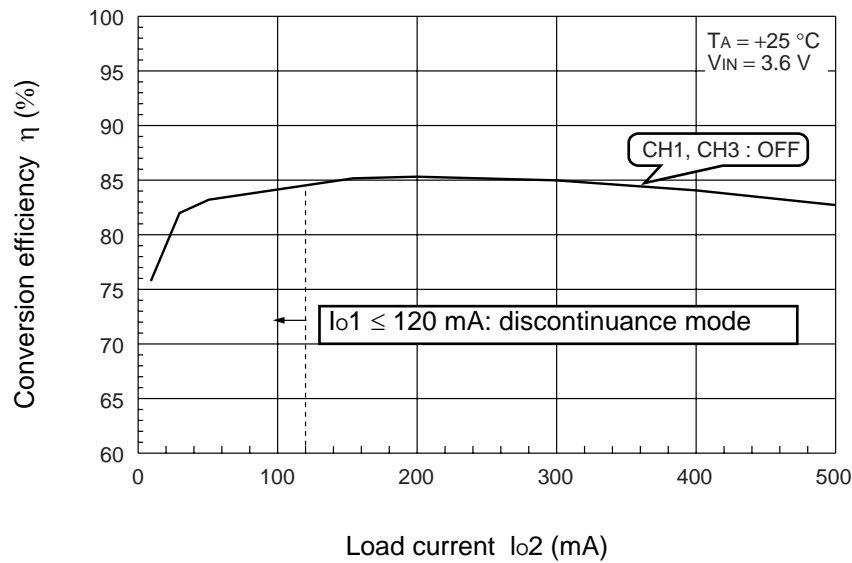

(Continued)

### Conversion Efficiency vs. Load Current (CH3, CH4)

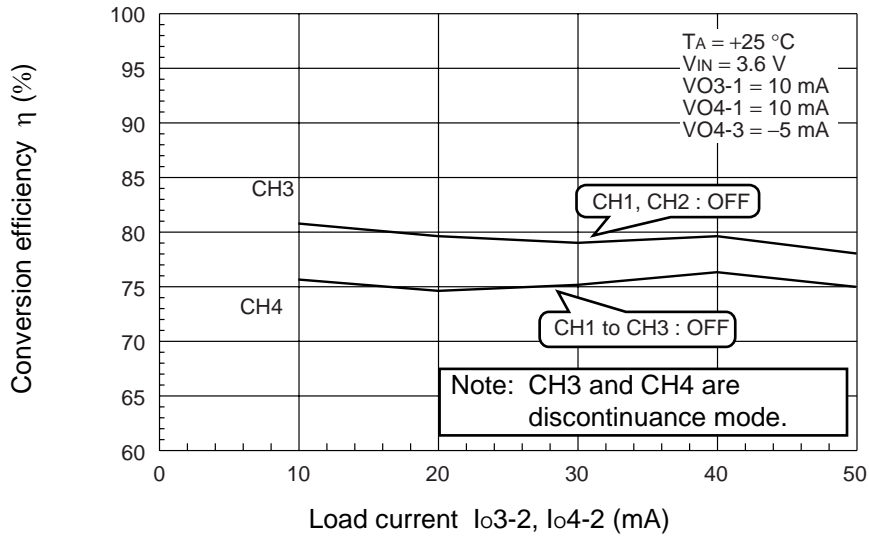

(Continued)

(Continued)

### Switching Wave Form (CH1)

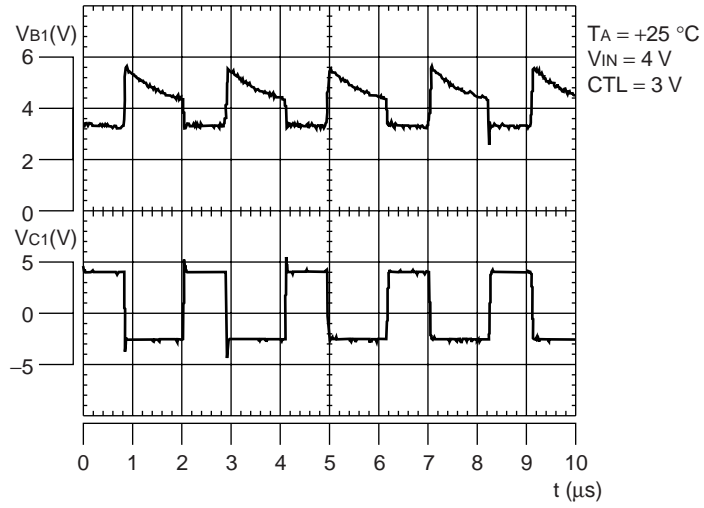

### Switching Wave Form (CH2)

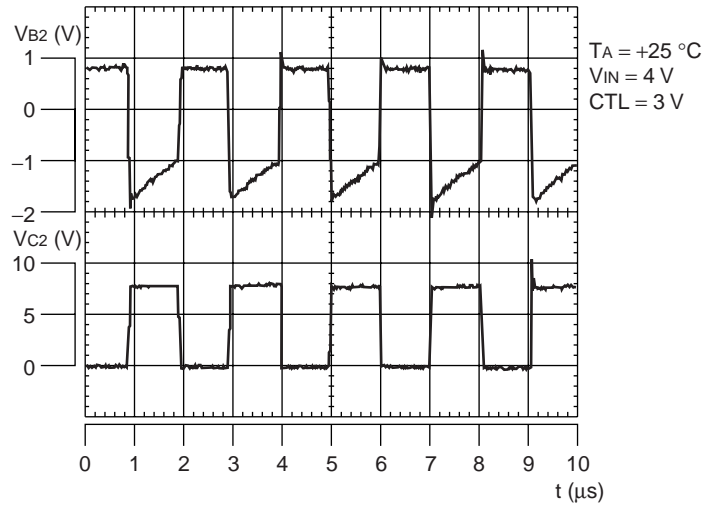

# MB39A103

## ■ USAGE PRECAUTION

- Printed circuit board ground lines should be set up with consideration for common impedance.
- Take appropriate static electricity measures.
  - Containers for semiconductor materials should have anti-static protection or be made of conductive material.
  - After mounting, printed circuit boards should be stored and shipped in conductive bags or containers.
  - Work platforms, tools, and instruments should be properly grounded.
  - Working personnel should be grounded with resistance of 250 k $\Omega$  to 1 M $\Omega$  between body and ground.
- Do not apply negative voltages.

The use of negative voltages below  $-0.3$  V may create parasitic transistors on LSI lines, which can cause abnormal operation.

## ■ ORDERING INFORMATION

Part number	Package	Remarks
MB39A103PFT	30-pin plastic TSSOP (FPT-30P-M04)	
MB39A103PV3	32-pad plastic BCC (LCC-32P-M15)	

## ■ PACKAGE DIMENSIONS

30-pin plastic TSSOP  
(FPT-30P-M04)

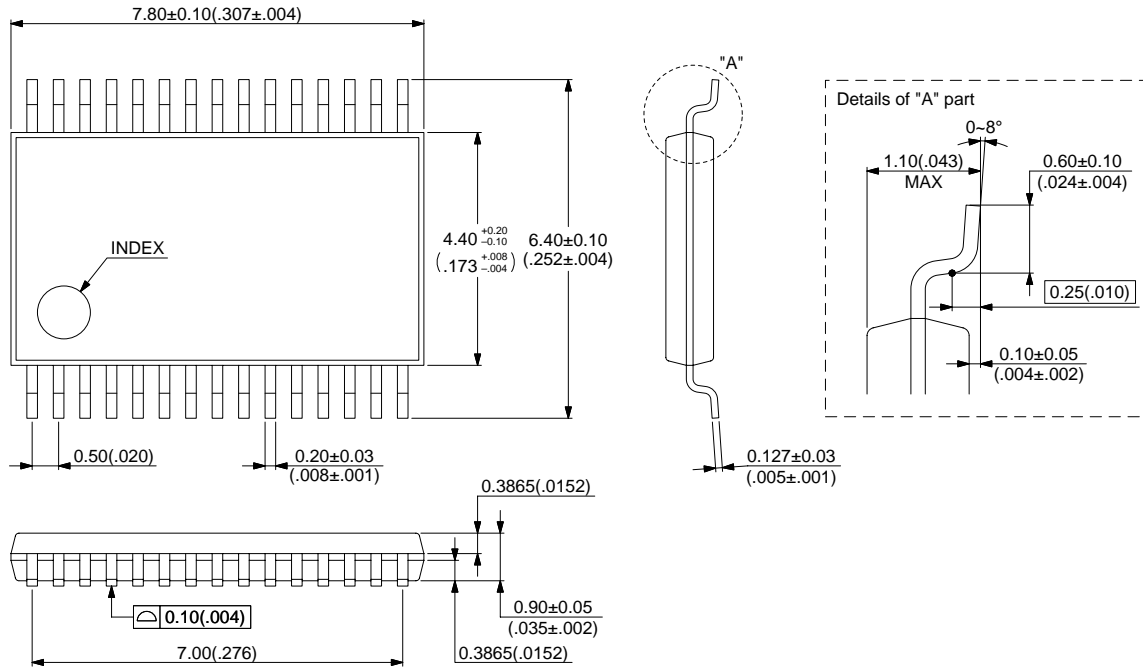

© 2001 FUJITSU LIMITED F30007SC-1-1

Dimensions in mm (inches)  
Note: The values in parentheses are reference values.

(Continued)



**MEMO**

**MEMO**

**MEMO**

# FUJITSU MICROELECTRONICS LIMITED

Shinjuku Dai-Ichi Seimei Bldg. 7-1, Nishishinjuku 2-chome, Shinjuku-ku,  
Tokyo 163-0722, Japan Tel: +81-3-5322-3347 Fax: +81-3-5322-3387  
<http://jp.fujitsu.com/fml/en/>

*For further information please contact:*

## **North and South America**

FUJITSU MICROELECTRONICS AMERICA, INC.  
1250 E. Arques Avenue, M/S 333  
Sunnyvale, CA 94085-5401, U.S.A.  
Tel: +1-408-737-5600 Fax: +1-408-737-5999  
<http://www.fma.fujitsu.com/>

## **Europe**

FUJITSU MICROELECTRONICS EUROPE GmbH  
Pittlerstrasse 47, 63225 Langen,  
Germany  
Tel: +49-6103-690-0 Fax: +49-6103-690-122  
<http://emea.fujitsu.com/microelectronics/>

## **Korea**

FUJITSU MICROELECTRONICS KOREA LTD.  
206 KOSMO TOWER, 1002 Daechi-Dong,  
Kangnam-Gu, Seoul 135-280  
Korea  
Tel: +82-2-3484-7100 Fax: +82-2-3484-7111  
<http://www.fmk.fujitsu.com/>

## **Asia Pacific**

FUJITSU MICROELECTRONICS ASIA PTE LTD.  
151 Lorong Chuan, #05-08 New Tech Park,  
Singapore 556741  
Tel: +65-6281-0770 Fax: +65-6281-0220  
<http://www.fujitsu.com/sg/services/micro/semiconductor/>

FUJITSU MICROELECTRONICS SHANGHAI CO., LTD.  
Rm.3102, Bund Center, No.222 Yan An Road(E),  
Shanghai 200002, China  
Tel: +86-21-6335-1560 Fax: +86-21-6335-1605  
<http://cn.fujitsu.com/fmc/>

FUJITSU MICROELECTRONICS PACIFIC ASIA LTD.  
10/F., World Commerce Centre, 11 Canton Road  
Tsimshatsui, Kowloon  
Hong Kong  
Tel: +852-2377-0226 Fax: +852-2376-3269  
<http://cn.fujitsu.com/fmc/tw>

All Rights Reserved.

The contents of this document are subject to change without notice.

Customers are advised to consult with sales representatives before ordering.

The information, such as descriptions of function and application circuit examples, in this document are presented solely for the purpose of reference to show examples of operations and uses of FUJITSU MICROELECTRONICS device; FUJITSU MICROELECTRONICS does not warrant proper operation of the device with respect to use based on such information. When you develop equipment incorporating the device based on such information, you must assume any responsibility arising out of such use of the information.

FUJITSU MICROELECTRONICS assumes no liability for any damages whatsoever arising out of the use of the information.

Any information in this document, including descriptions of function and schematic diagrams, shall not be construed as license of the use or exercise of any intellectual property right, such as patent right or copyright, or any other right of FUJITSU MICROELECTRONICS or any third party or does FUJITSU MICROELECTRONICS warrant non-infringement of any third-party's intellectual property right or other right by using such information. FUJITSU MICROELECTRONICS assumes no liability for any infringement of the intellectual property rights or other rights of third parties which would result from the use of information contained herein.

The products described in this document are designed, developed and manufactured as contemplated for general use, including without limitation, ordinary industrial use, general office use, personal use, and household use, but are not designed, developed and manufactured as contemplated (1) for use accompanying fatal risks or dangers that, unless extremely high safety is secured, could have a serious effect to the public, and could lead directly to death, personal injury, severe physical damage or other loss (i.e., nuclear reaction control in nuclear facility, aircraft flight control, air traffic control, mass transport control, medical life support system, missile launch control in weapon system), or (2) for use requiring extremely high reliability (i.e., submersible repeater and artificial satellite).

Please note that FUJITSU MICROELECTRONICS will not be liable against you and/or any third party for any claims or damages arising in connection with above-mentioned uses of the products.

Any semiconductor devices have an inherent chance of failure. You must protect against injury, damage or loss from such failures by incorporating safety design measures into your facility and equipment such as redundancy, fire protection, and prevention of over-current levels and other abnormal operating conditions.

Exportation/release of any products described in this document may require necessary procedures in accordance with the regulations of the Foreign Exchange and Foreign Trade Control Law of Japan and/or US export control laws.

The company names and brand names herein are the trademarks or registered trademarks of their respective owners.