

## ASSP For Power Supply Applications

# 6-ch DC/DC Converter IC With Synchronous Rectifier

## MB3825A

### ■ DESCRIPTION

The MB3825A is a pulse width modulation (PWM) type 6-channel DC/DC converter IC with synchronous rectification (2-channels) designed for low voltage, high efficiency operation in high precision and high frequency applications, ideal for down conversion.

The MB3825A is an ideal device offering low power consumption, compact size and light weight for products such as self-contained camcorders and digital still cameras.

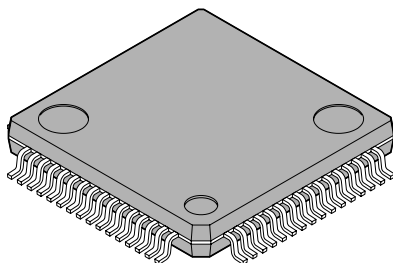
This product is covered by US Patent Number 6,147,477.

### ■ FEATURES

- Synchronous rectification (channels 1 and 4)
- High efficiency drive with power-on output enhanced by built-in speed-up circuit
- Wide range of operating power supply voltage : 2.5 V to 12 V
- Built-in high-precision reference voltage generator :  $1.5\text{ V} \pm 1\%$
- Wide operating oscillator frequency range, high frequency capability : 50 kHz to 800 kHz
- Wide input voltage range (all channels) : 0 V to  $V_{cc} - 0.9\text{ V}$
- Error amplifier output for soft-start (channels 1, 2, 4) (All channels may be set for same soft-start time regardless of duty factor setting.)

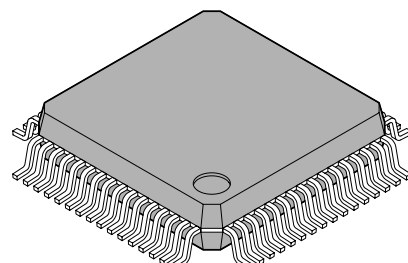
### ■ PACKAGE

64-pin plastic LQFP



(FPT-64P-M03)

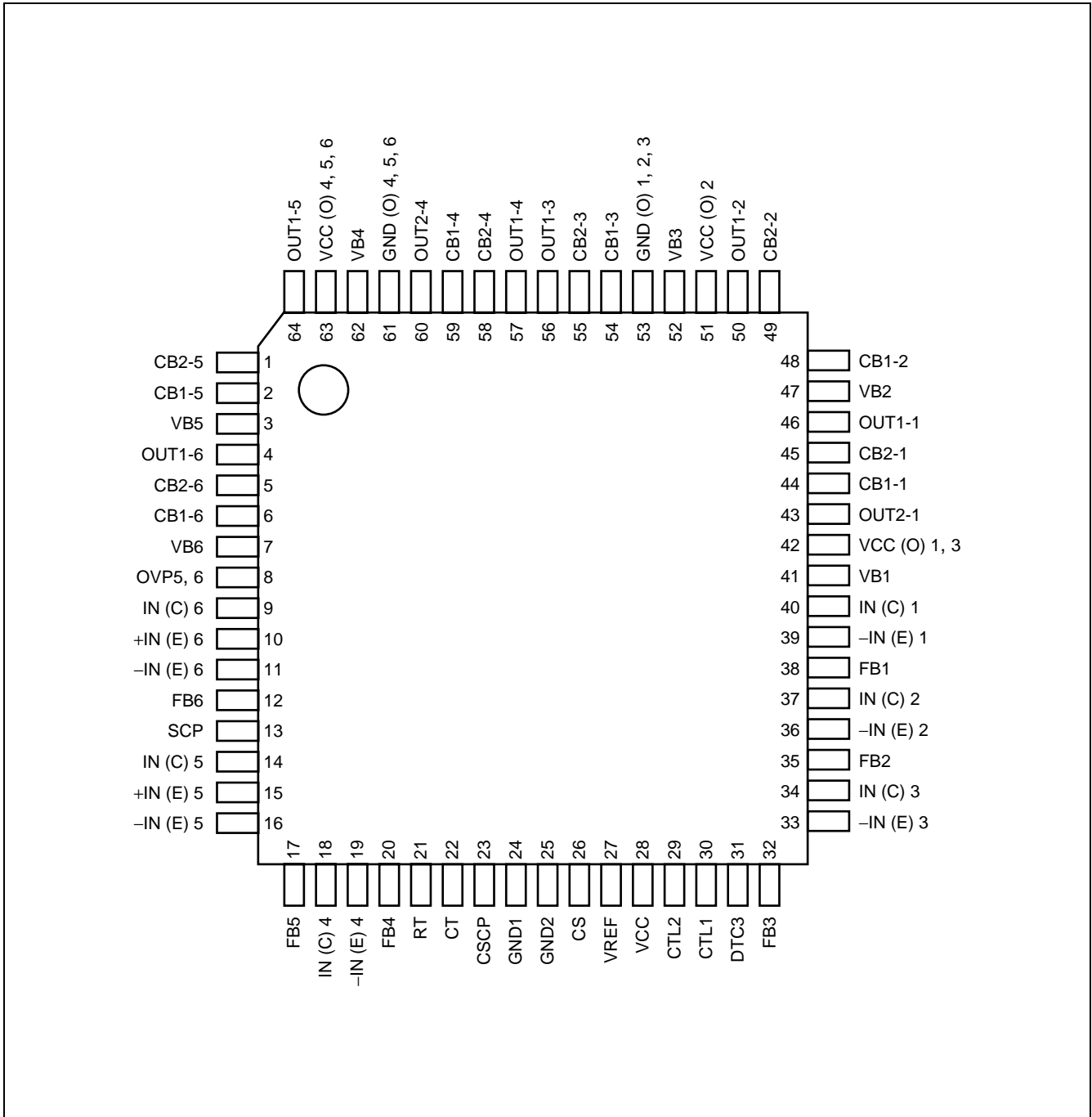
64-pin plastic LQFP



(FPT-64P-M20)

# MB3825A

## ■ PIN ASSIGNMENT



## ■ PIN DESCRIPTION

Pin No.	Symbol	I/O	Descriptions	
CH 1	38	FB1	O	Channel 1 error amplifier output terminal.
	39	-IN (E) 1	I	Channel 1 error amplifier inverted input terminal.
	40	IN (C) 1	I	Channel 1 short detection comparator input terminal.
	46	OUT1-1	O	Channel 1 main side output terminal.
	43	OUT2-1	O	Channel 1 synchronous rectifier side output terminal.
	44	CB1-1	—	Channel 1 boot capacitor connection terminal.
	45	CB2-1	—	
	41	VB1	—	Channel 1 output sink current setting terminal.
CH 2	35	FB2	O	Channel 2 error amplifier output terminal.
	36	-IN (E) 2	I	Channel 2 error amplifier inverted input terminal.
	37	IN (C) 2	I	Channel 2 short detection comparator input terminal.
	50	OUT1-2	O	Channel 2 output terminal.
	48	CB1-2	—	Channel 2 boot capacitor connection terminal.
	49	CB2-2	—	
	47	VB2	—	Channel 2 output sink current setting terminal.
CH 3	32	FB3	O	Channel 3 error amplifier output terminal.
	33	-IN (E) 3	I	Channel 3 error amplifier inverted input terminal.
	34	IN (C) 3	I	Channel 3 short detection comparator input terminal.
	56	OUT1-3	O	Channel 3 output terminal.
	54	CB1-3	—	Channel 3 boot capacitor connection terminal.
	55	CB2-3	—	
	52	VB3	—	Channel 3 output sink current setting terminal.
	31	DTC3	I	Channel 3 dead time control terminal.
CH 4	20	FB4	O	Channel 4 error amplifier output terminal.
	19	-IN (E) 4	I	Channel 4 error amplifier inverted input terminal.
	18	IN (C) 4	I	Channel 4 short detection comparator input terminal.
	57	OUT1-4	O	Channel 4 main side output terminal.
	60	OUT2-4	O	Channel 4 synchronous rectifier side output terminal.
	59	CB1-4	—	Channel 4 boot capacitor connection terminal.
	58	CB2-4	—	
	62	VB4	—	Channel 4 output sink current setting terminal.

(Continued)

# MB3825A

Pin No.	Symbol	I/O	Descriptions	
CH 5	17	FB5	O	Channel 5 error amplifier output terminal.
	16	-IN (E) 5	I	Channel 5 error amplifier inverted input terminal.
	15	+IN (E) 5	I	Channel 5 error amplifier non-inverted input terminal.
	14	IN (C) 5	I	Channel 5 short detection comparator input terminal.
	64	OUT1-5	O	Channel 5 output terminal.
	2	CB1-5	—	Channel 5 boot capacitor connection terminal.
	1	CB2-5	—	
	3	VB5	—	Channel 5 output sink current setting terminal.
	8	OVP5, 6	I	Channel 5, 6 output maximum voltage setting terminal.
CH 6	12	FB6	O	Channel 6 error amplifier output terminal.
	11	-IN (E) 6	I	Channel 6 error amplifier inverted input terminal.
	10	+IN (E) 6	I	Channel 6 error amplifier non-inverted input terminal.
	9	IN (C) 6	I	Channel 6 short detection comparator input terminal.
	4	OUT1-6	O	Channel 6 output terminal.
	6	CB1-6	—	Channel 6 boot capacitor connection terminal.
	5	CB2-6	—	
	7	VB6	—	Channel 6 output sink current setting terminal.
	8	OVP5, 6	I	Channel 5, 6 output maximum voltage setting terminal.
Triangular-Wave Oscillator Circuit	21	RT	—	Triangular wave frequency setting resistor connection terminal.
	22	CT	—	Triangular wave frequency setting capacitor connection terminal.
Control Circuit	30	CTL1	I	Power supply control circuit. “H” level : Power supply operating mode “L” level : Standby mode
	29	CTL2	I	Channel 3 control circuit. When CTL1 terminal is “H” level “H” level : Channel 3 in operating mode “L” level : Channel 3 in OFF mode
	13	SCP	I	Short detection comparator input terminal.
	23	CSCP	—	Short protection circuit capacitor connection terminal.
	26	CS	—	Soft-start circuit capacitor connection terminal.

(Continued)

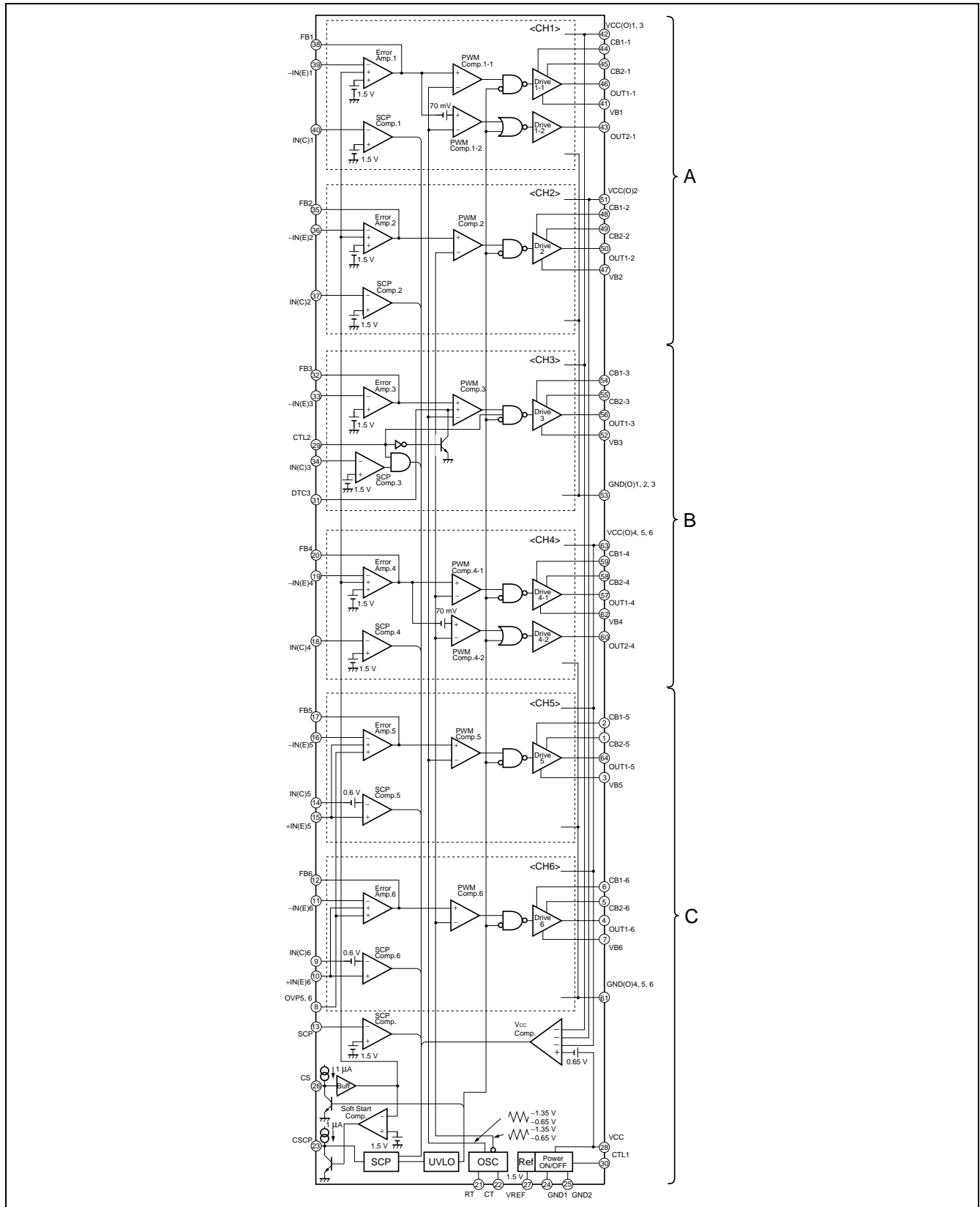
(Continued)

Pin No.	Symbol	I/O	Descriptions	
Power Supply Circuit	28	VCC	—	Reference voltage and control circuit power supply terminal.
	42	VCC (O) 1, 3	—	Output circuit power supply terminal (Channel 1, 3) .
	51	VCC (O) 2	—	Output circuit power supply terminal (Channel 2) .
	63	VCC (O) 4, 5, 6	—	Output circuit power supply terminal (Channel 4, 5, 6) .
	27	VREF	O	Reference voltage output terminal.
	24	GND1	—	Ground terminal.
	25	GND2	—	Ground terminal.
	53	GND (O) 1, 2, 3	—	Output circuit ground terminal (Channel 1, 2, 3) .
	61	GND (O) 4, 5, 6	—	Output circuit ground terminal (Channel 4, 5, 6) .

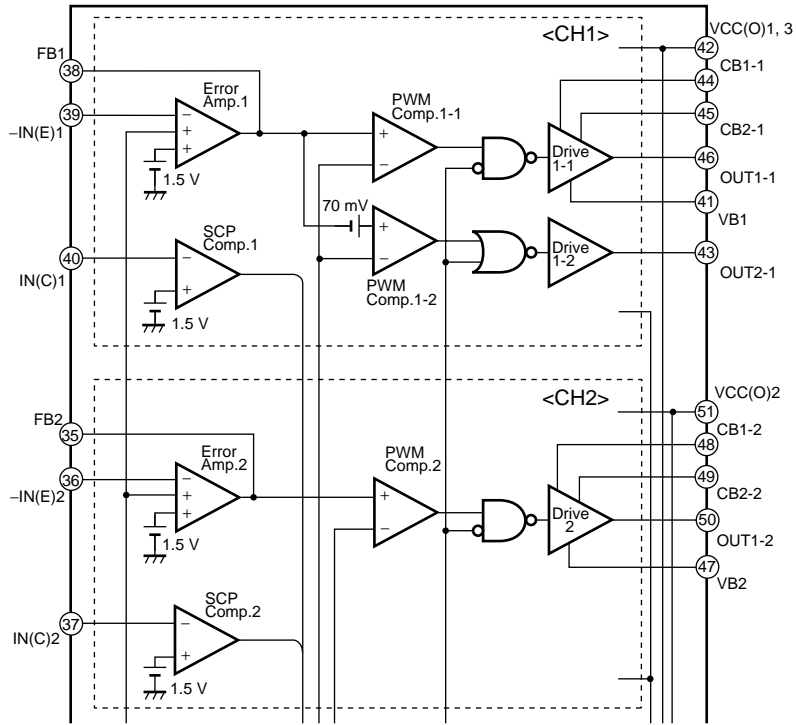
# MB3825A

## ■ BLOCK DIAGRAM

### • General view

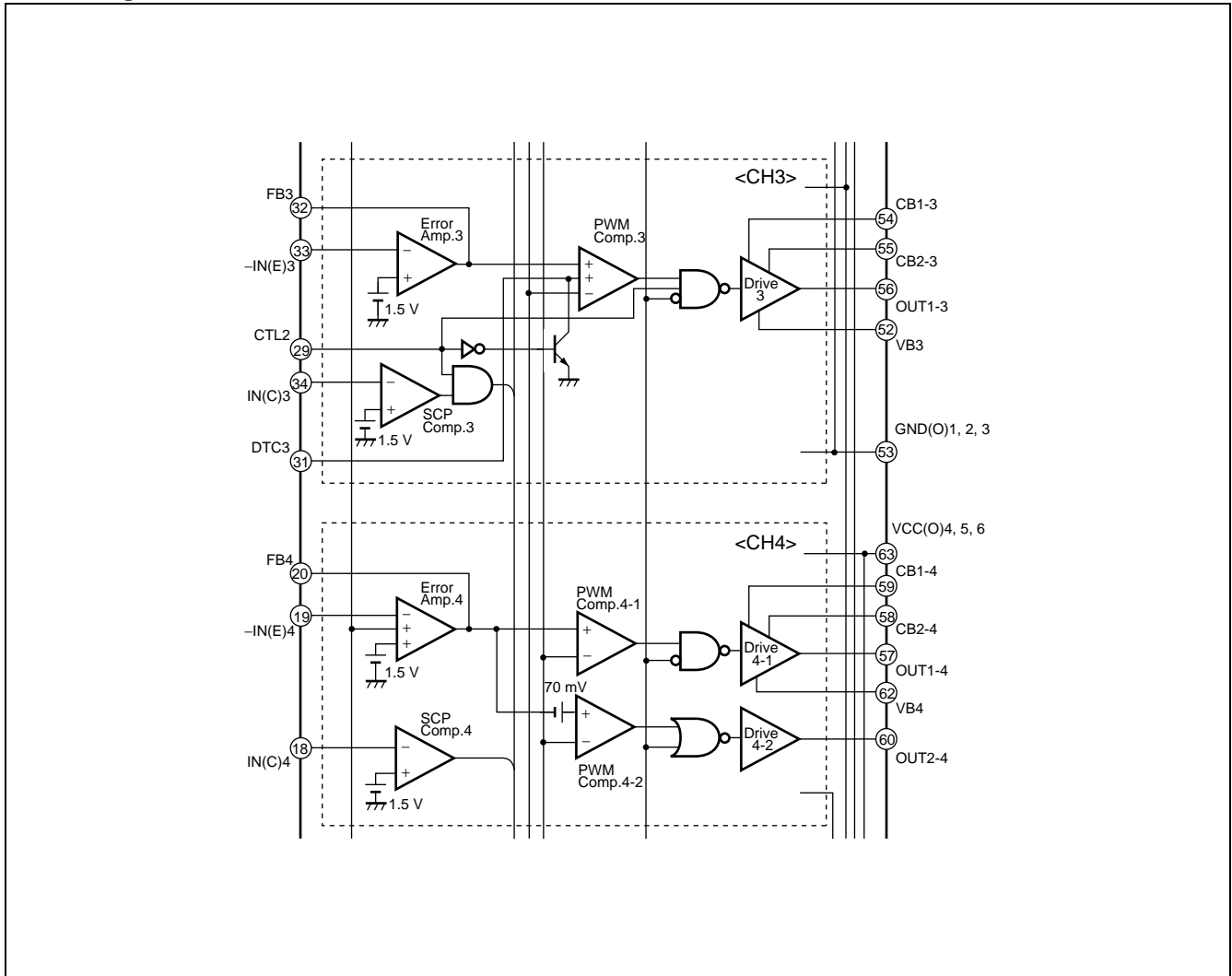


• Enlarged view of A

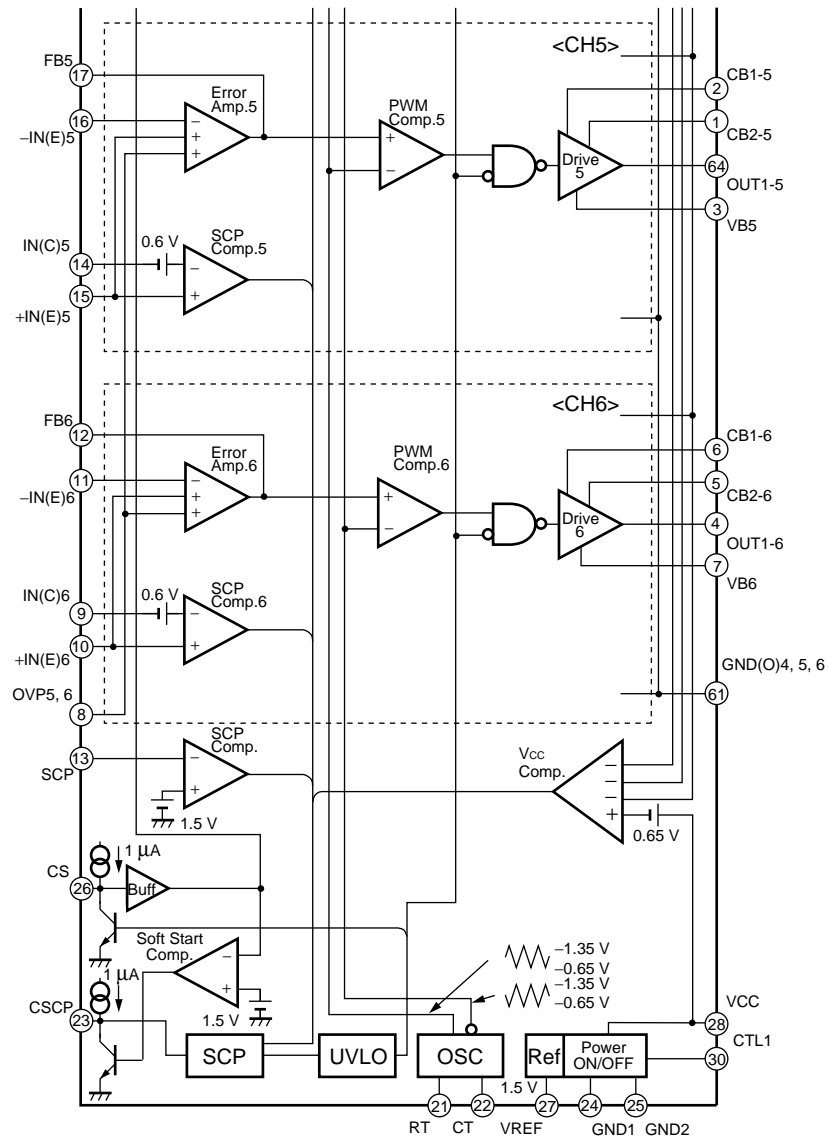


# MB3825A

## • Enlarged view of B



• Enlarged view of C



# MB3825A

## ■ ABSOLUTE MAXIMUM RATINGS

Parameter	Symbol	Conditions	Rating		Unit
			Min	Max	
Power supply voltage	V <sub>CC</sub>	—	—	17	V
Output current	I <sub>O</sub>	OUT terminal	—	50	mA
Output peak current	I <sub>O</sub>	OUT terminal, Duty ≤ 5%	—	200	mA
Power dissipation	P <sub>D</sub>	T <sub>a</sub> ≤ +25 °C	—	800*	mW
Storage temperature	T <sub>stg</sub>	—	-55	+125	°C

\* : The packages are mounted on the epoxy board (10 cm × 10 cm) .

WARNING: Semiconductor devices can be permanently damaged by application of stress (voltage, current, temperature, etc.) in excess of absolute maximum ratings. Do not exceed these ratings.

## ■ RECOMMENDED OPERATING CONDITIONS

Parameter	Symbol	Conditions	Value			Unit
			Min	Typ	Max	
Power supply voltage	V <sub>CC</sub>	—	2.5	6.0	12	V
Reference voltage output current	I <sub>OR</sub>	—	-1	—	0	mA
Input voltage	V <sub>IN</sub>	-IN (E) , IN (C) , OVP terminal	0	—	V <sub>CC</sub> - 0.9	V
Control input voltage	V <sub>CTL</sub>	CTL terminal	0	—	12	V
Output current	I <sub>O</sub>	Main side OUT terminal	2	—	20	mA
Output current setting resistor	R <sub>B</sub>	—	2.7	5.6	30	kΩ
Oscillator frequency	f <sub>OSC</sub>	—	50	500	800	kHz
Timing capacitor	C <sub>T</sub>	—	50	100	1500	pF
Timing resistor	R <sub>T</sub>	—	20	39	82	kΩ
Soft-start capacitor	C <sub>S</sub>	—	—	0.1	1.0	μF
Short detection capacitor	C <sub>SCP</sub>	—	—	0.1	1.0	μF
Operating ambient temperature	T <sub>a</sub>	—	-30	+25	+85	°C

WARNING: The recommended operating conditions are required in order to ensure the normal operation of the semiconductor device. All of the device's electrical characteristics are warranted when the device is operated within these ranges.

Always use semiconductor devices within their recommended operating condition ranges. Operation outside these ranges may adversely affect reliability and could result in device failure.

No warranty is made with respect to uses, operating conditions, or combinations not represented on the data sheet. Users considering application outside the listed conditions are advised to contact their representatives beforehand.

## ■ ELECTRICAL CHARACTERISTICS

( $V_{CC} = V_{CC(O)} = +6\text{ V}$ ,  $T_a = +25^\circ\text{C}$ )

Parameter	Symbol	Pin No.	Conditions	Value			Unit	
				Min	Typ	Max		
Reference voltage block	Reference voltage	$V_{REF}$	27	—	1.485	1.500	1.515	V
	Output voltage temperature stability	$\frac{\Delta V_{REF}}{V_{REF}}$	27	$T_a = -30^\circ\text{C to } +85^\circ\text{C}$	—	0.5*	—	%
	Input stability	Line	27	$V_{CC} = 2.5\text{ V to } 12\text{ V}$	—	2	10	mV
	Load stability	Load	27	$V_{REF} = 0\text{ mA to } -1\text{ mA}$	—	2	10	mV
	Short-circuit output current	$I_{OS}$	27	$V_{REF} = 2\text{ V}$	-10	-6	-1	mA
Under voltage lockout protection circuit block (U.V.L.O)	Threshold voltage	$V_{TH}$	46	$V_{CC} = \underline{\text{L}}$	—	2.1	—	V
	Hysteresis width	$V_H$	46	—	—	0.1	—	V
	Reset voltage	$V_{RST}$	46	—	1.8	2.0	—	V
Soft-start block	Input standby voltage	$V_{STB}$	26	—	—	50	100	mV
	Charge current	$I_{CS}$	26	—	-1.4	-1.0	-0.6	$\mu\text{A}$
Short circuit detection block	Threshold voltage	$V_{TH}$	23	—	0.65	0.70	0.75	V
	Input standby voltage	$V_{STB}$	23	—	—	50	100	mV
	Input latch voltage	$V_I$	23	—	—	50	100	mV
	Input source current	$I_{CSCP}$	23	—	-1.4	-1.0	-0.6	$\mu\text{A}$
Triangular wave oscillator block	Oscillator frequency	$f_{OSC}$	46, 50, 56, 57, 64, 4	$C_T = 100\text{ pF}$ , $R_T = 39\text{ k}\Omega$	450	500	550	kHz
	Frequency stability for voltage	$\Delta f/f_{dv}$	46, 50, 56, 57, 64, 4	$V_{CC} = 2.5\text{ V to } 12\text{ V}$	—	1	10	%
	Frequency stability for temperature	$\Delta f/f_{dt}$	46, 50, 56, 57, 64, 4	$T_a = -30^\circ\text{C to } +85^\circ\text{C}$	—	1*	—	%

\* : Standard design value.

(Continued)

# MB3825A

( $V_{CC} = V_{CC(O)} = +6\text{ V}$ ,  $T_a = +25^\circ\text{C}$ )

Parameter	Symbol	Pin No	Conditions	Value			Unit	
				Min	Typ	Max		
Error amplifier block (CH1 to CH4)	Threshold voltage	$V_{TH}$	38, 35, 32, 20	FB = 1.0 V	1.45	1.50	1.55	V
	$V_T$ temperature stability	$\Delta V_T/V_T$	38, 35, 32, 20	$T_a = -30^\circ\text{C}$ to $+85^\circ\text{C}$	—	0.5*	—	%
	Input bias current	$I_B$	39, 36, 33, 19	-IN = 0 V	-200	-20	—	nA
	Voltage gain	$A_V$	38, 35, 32, 20	DC	60	75	—	dB
	Frequency bandwidth	BW	38, 35, 32, 20	$A_V = 0\text{ dB}$	—	1.0*	—	MHz
	Maximum output voltage width	$V_{OM}^+$	38, 35, 32, 20	—	1.45	1.55	—	V
		$V_{OM}^-$	38, 35, 32, 20	—	—	20	200	mV
	Output source current	$I_{O^-}$	38, 35, 32, 20	FB = 1.0 V	—	-2.0	-0.6	mA
	Output sink current	$I_{O^+}$	38, 20	FB = 1.0 V (CH1, CH4)	60	120	—	$\mu\text{A}$
35, 32			FB = 1.0 V (CH2, CH3)	60	130	—	$\mu\text{A}$	
Error amplifier block (CH5, CH6)	Input offset voltage	$V_{IO}$	17, 12	FB = 1.0 V	-1	9	19	mV
	Input bias current	$I_B$	15, 10	+IN = 0 V, +IN (E) terminal	-400	-40	—	nA
			16, 11	-IN = 0 V, -IN (E) terminal	-200	-20	—	nA
			8	OVP = 0 V, OVP terminal	-400	-40	—	nA
	Common mode input voltage range	$V_{CM}$	17, 12	—	0	—	$V_{CC} - 0.9$	V
	Voltage gain	$A_V$	17, 12	DC	60	75	—	dB
	Frequency bandwidth	BW	17, 12	$A_V = 0\text{ dB}$	—	1.0*	—	MHz
	Maximum output voltage width	$V_{OM}^+$	17, 12	—	1.45	1.55	—	V
		$V_{OM}^-$	17, 12	—	—	20	200	mV
	Output source current	$I_{O^-}$	17, 12	FB = 1.0 V	—	-2.0	-0.6	mA
Output sink current	$I_{O^+}$	17, 12	FB = 1.0 V	60	130	—	$\mu\text{A}$	
SCP Comp. block (CH1 to CH4, SCP)	Threshold voltage	$V_{TH}$	46, 50, 56, 57	—	1.45	1.50	1.55	V
	Input bias current	$I_B$	40, 37, 34, 18, 13	IN (C) = SCP = 0 V	-200	-20	—	nA

\* : Standard design value.

(Continued)

(Continued)

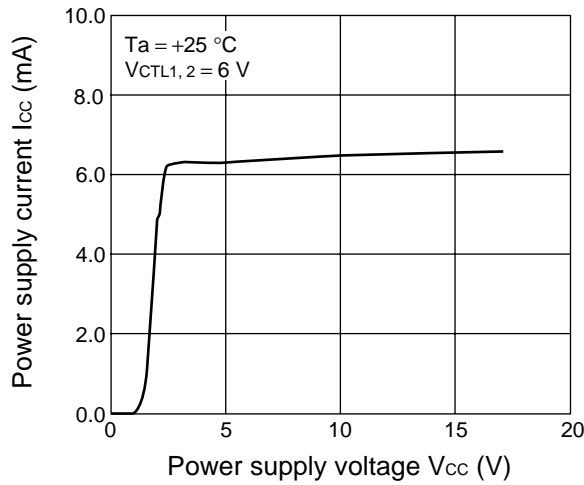
( $V_{CC} = V_{CC(O)} = +6\text{ V}$ ,  $T_a = +25^\circ\text{C}$ )

Parameter		Symbol	Pin No	Conditions	Value			Unit
					Min	Typ	Max	
SCP Comp. block (CH5, CH6)	Input offset voltage	$V_{IO}$	64, 4	—	0.55	0.60	0.65	V
	Input bias current	$I_{IN^+}$	14, 9	IN (C) = 0 V	-400	-40	—	nA
	Common mode input voltage range	$V_{CM}$	64, 4	—	0	—	$V_{CC} - 0.9$	V
PWM Comp. block (CH1 to CH6)	Threshold voltage	$V_{TO}$	46, 50, 56, 57, 64, 4	Duty cycle = 0%	0.55	0.65	—	V
		$V_{T100}$	46, 50, 56, 57, 64, 4	Duty cycle = 100%	—	1.35	1.45	V
Dead time control block (CH3) (DTC terminal)	Input bias current	$I_B$	31	DTC = 0.4 V	-1.0	-0.2	—	$\mu\text{A}$
	Sink current at CTL2 = "L"	$I_{DTC}$	31	DTC = 1.5 V CTL2 = 0 V	80	500	—	$\mu\text{A}$
	Input voltage at CTL2 = "L"	$V_{DTC}$	31	IDTC = 40 $\mu\text{A}$ CTL2 = 0 V	—	0.2	0.3	V
Main side output block (CH1 to CH6) (Drive-1)	Output source current	$I_{O^-}$	46, 50, 56, 57, 64, 4	Duty cycle $\leq 5\%$	—	-100	—	mA
	Output sink current	$I_{O^+}$	46, 50, 56, 57, 64, 4	$R_B = 5.6\text{ k}\Omega$	7	10	13	mA
Synchron- ous rectifier side output block (CH1, CH4) (Drive-2)	Output source current	$I_{O^-}$	43, 60	Duty cycle $\leq 5\%$ , $V_O = 2\text{ V}$	—	-70	—	mA
	Output sink current	$I_{O^+}$	43, 60	Duty cycle $\leq 5\%$ , $V_O = 1\text{ V}$	—	70	—	mA
	Output voltage	$V_{OH}$	43, 60	—	3.5	4.0	—	V
		$V_{OL}$	43, 60	—	—	0	0.1	V
Control block	CTL input condition	$V_{ON}$	27	IC active mode	2.1	—	12	V
		$V_{OFF}$	27	IC standby mode	0	—	0.7	V
	Input current	$I_{CTL}$	30	CTL = 5 V	—	100	200	$\mu\text{A}$
$V_{CC}$ Comp. block	Threshold voltage	$V_{TH}$	46, 50, 56	—	$V_{CC} - 0.70$	$V_{CC} - 0.65$	$V_{CC} - 0.60$	V
General	Standby current	$I_{CCS}$	28	VCC terminal, CTL = 0 V	—	—	10	$\mu\text{A}$
		$I_{CCS(o)}$	42, 51, 63	VCC (O) terminal, CTL = 0 V	—	—	10	$\mu\text{A}$
	Power supply current	$I_{CC}$	28, 42, 51, 63	—	—	6.3	9.0	mA

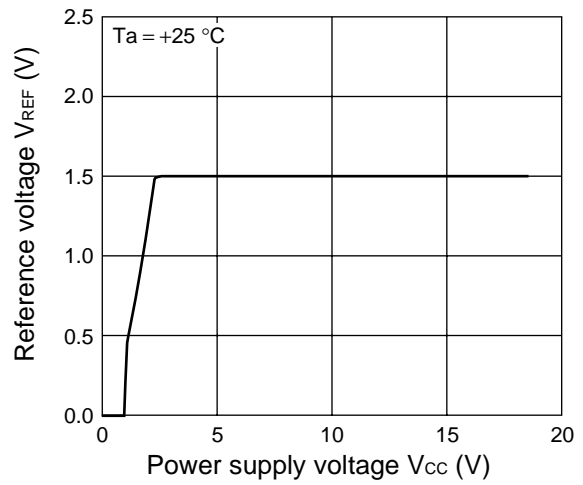
\* : Standard design value.

## ■ TYPICAL CHARACTERISTICS

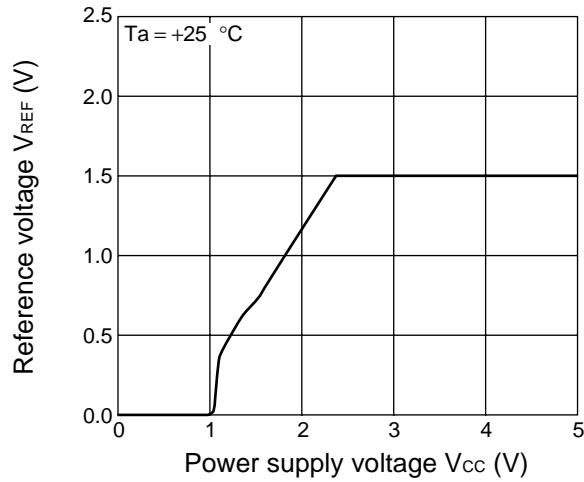
Power supply current vs. power supply voltage



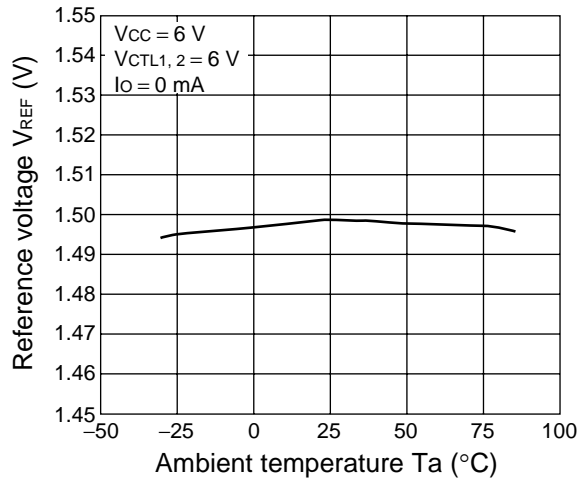
Reference voltage vs. power supply voltage



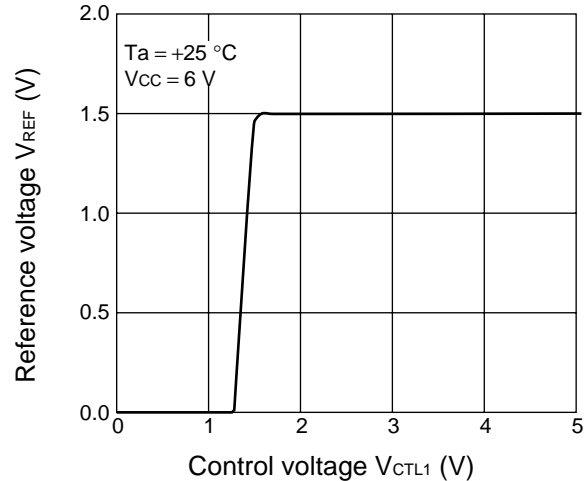
Reference voltage vs. power supply voltage



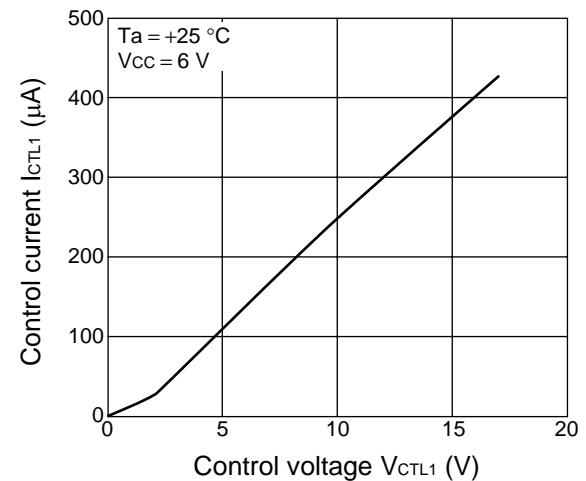
Reference voltage vs. ambient temperature



Reference voltage vs. control voltage

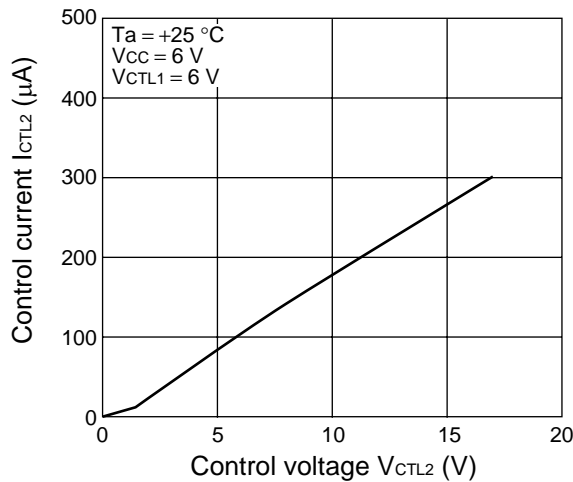


Control current vs. control voltage

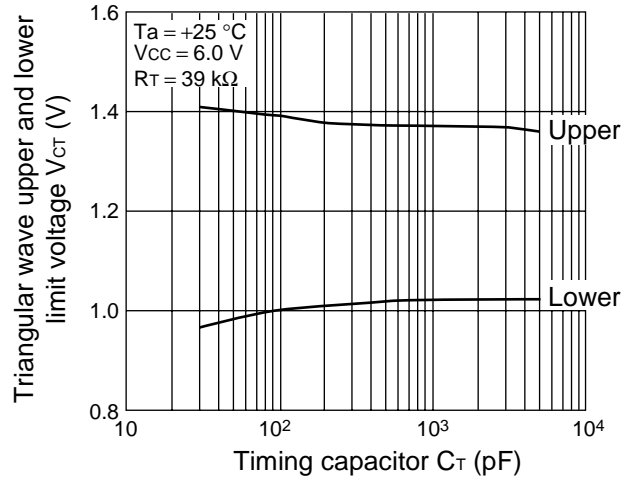


(Continued)

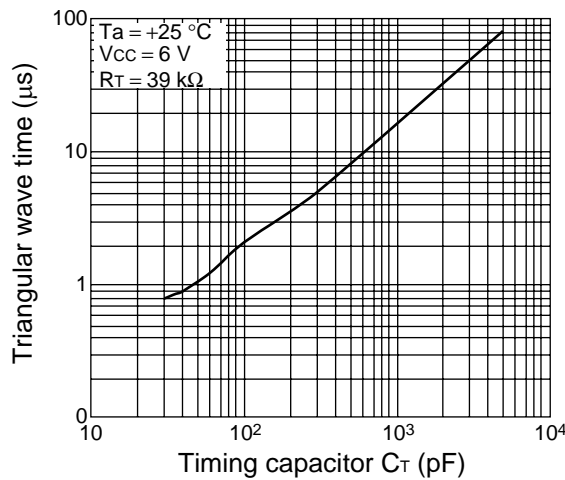
Control current vs. control voltage



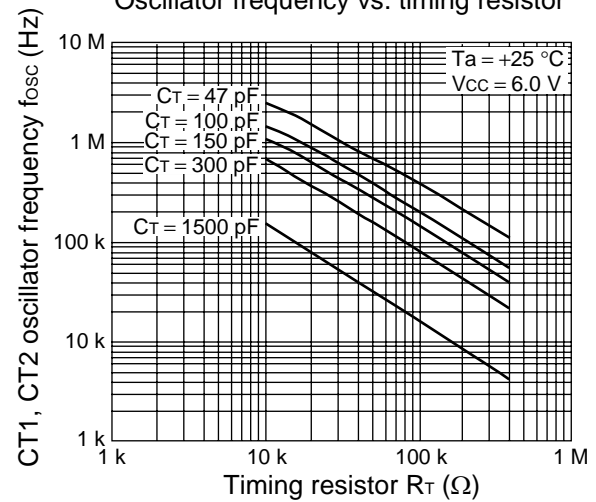
Triangular wave upper and lower limit voltage vs. timing capacitor



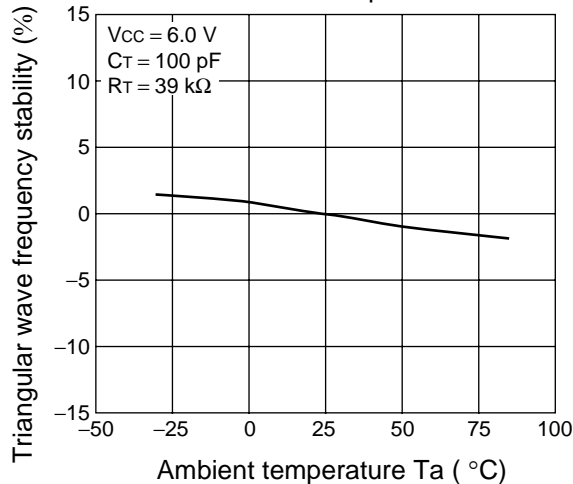
Triangular wave time vs. timing capacitor



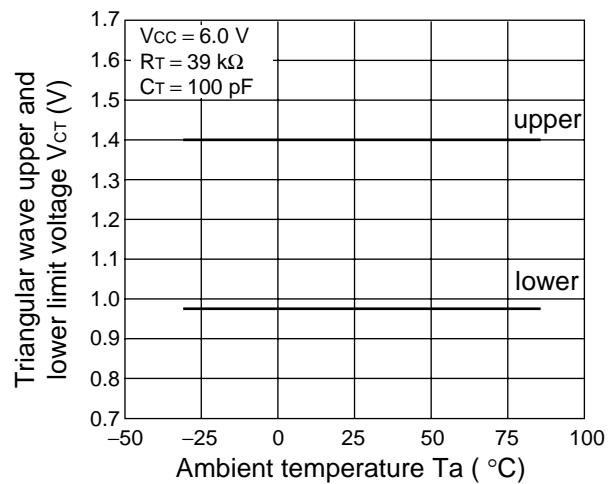
Oscillator frequency vs. timing resistor



Triangular wave frequency stability vs. ambient temperature

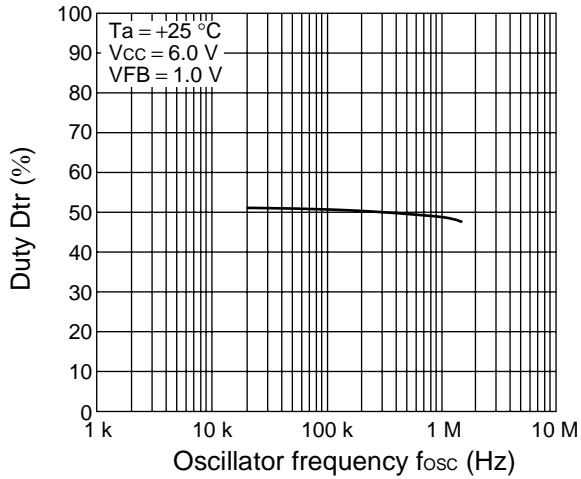


Triangular wave upper and lower limit voltage vs. ambient temperature

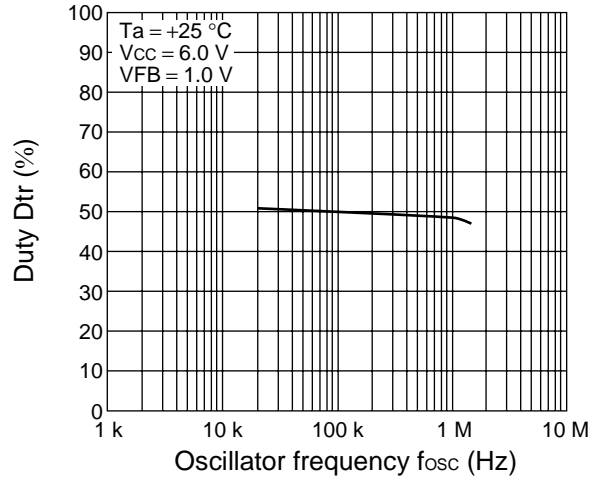


(Continued)

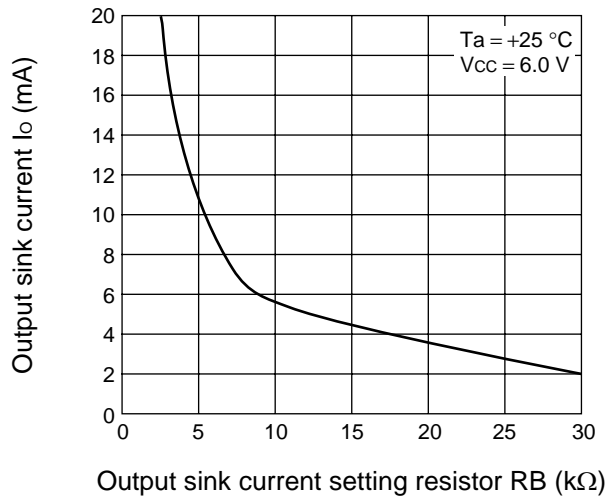
Duty vs. oscillator frequency (ch1)



Duty vs. oscillator frequency (ch4)



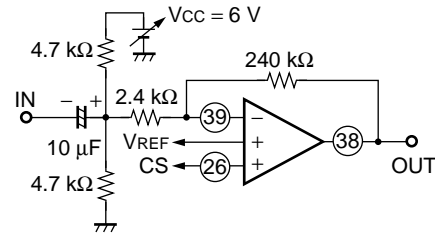
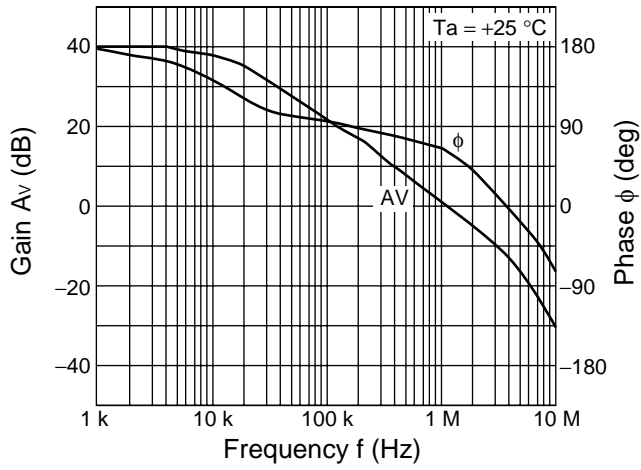
Output sink current vs. output sink current setting resistor



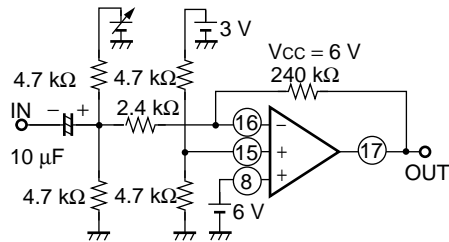
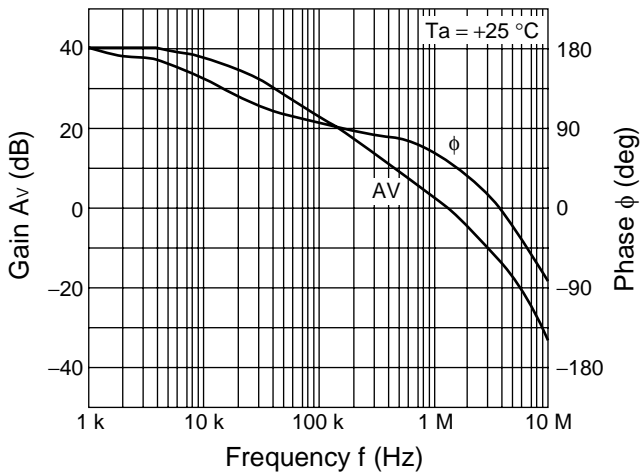
(Continued)

(Continued)

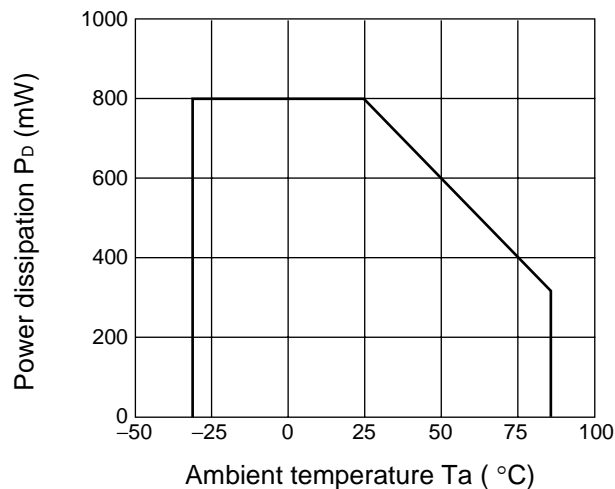
Error amplifier gain and phase vs. frequency (ch1)



Error amplifier gain and phase vs. frequency (ch5)



Power dissipation vs. ambient temperature



## ■ FUNCTIONAL DESCRIPTION

### 1. Switching Regulator Function

#### (1) Reference voltage circuit

The reference voltage circuit generates a temperature-compensated reference voltage ( $\approx 1.500$  V) using the voltage supplied from the power supply terminal (pin 28) . This voltage is used as the reference voltage for the internal circuits of the IC. The reference voltage of up to 1 mA can also be supplied to an external device from the VREF terminal (pin 27) .

#### (2) Triangular-wave oscillator circuit

By connecting a timing capacitor and a resistor to the  $C_T$  (pin 22) and the  $R_T$  (pin 21) terminals, it is possible to generate any desired triangular oscillator waveform (CT : amplitude 1.0 V to 1.4 V, CT1 : amplitude 0.65 V to 1.35 V in phase with CT, and CT2 : amplitude 0.65 V to 1.35 V in inverse phase with CT) . The triangular wave is input to CT1, CT2 and the PWM comparator within the IC.

#### (3) Error amplifier

This amplifier detects the output voltage of the switching regulator and outputs a PWM control signal accordingly. It has a wide common-mode input voltage range from 0 V to  $V_{CC} - 0.9$  V on channels 5 and 6 allows easy setting from an external power supply, making the system suitable for DC motor speed control.

By connecting a feedback resistor and capacitor from the error amplifier output terminal to the inverted input terminal, you can form any desired loop gain, for stable phase compensation.

#### (4) PWM comparator

The PWM comparators in these channels are a voltage comparator with one inverted input and one non-inverted input (channels 1, 2, 4, 5, 6) as well as one inverted input and two non-inverted inputs (channel 3) , and voltage pulse width modifier to control output duty according to input voltage.

In the interval when the error amplifier output voltage is higher than the triangular waveform, the output transistor is turned on (channels 1, 2, 4, 5, 6) .

In the interval when the error amplifier output voltage is lower than the triangular waveform, the output transistor is turned on (channel 1, 4 synchronous rectifier side) .

In the interval when the error amplifier output voltage and DTC3 voltage are higher than the triangular waveform, the output transistor is switched on (channel 3) .

#### (5) Output circuit

The output circuits is comprised of a totem-pole configuration on both the main side and synchronous rectifier side, and can drive an external PNP transistor (main side) or N-ch MOSFET (synchronous rectifier side) .

Sink current (on the main side) can be set up to 20 mA depending on the resistance of the VB terminal.

### 2. Channel Control Function

Channel on and off levels are dependent on the voltage levels of the CTL1 terminal (pin 30) and CTL 2 terminal (pin 29) .

**Table 1 Channel by Channel On/Off Setting Conditions.**

CTL terminal voltage level		On/Off state of channel						
CTL1	CTL2	Power supply circuit	Channel 1	Channel 2	Channel 4	Channel 5	Channel 6	Channel 3
L	X	OFF (standby mode) *						
H	L	ON						OFF
	H	ON						ON

\* : The power supply current in standby mode is 10  $\mu$ A or less.

## 3. Protective Functions

### (1) Timer-latch short-circuit protection circuit

The short detection comparator in each channel detects the output voltage level, and when any channel output voltage falls below the short detection voltage, or the SCP terminal (pin 13) voltage falls below the reference voltage, the timer circuit starts operating and the capacitor  $C_{SCP}$  connected to the CSCP terminal (pin 23) starts charging.

When the capacitor charge reaches approximately 0.7 V, the output transistor is turned off and the idle interval becomes 100%.

When actuated, this protection circuit can be reset by turning on the power supply again. (See "METHOD OF SETTING TIME CONSTANT FOR TIMER-LATCH SHORT PROTECTION CIRCUIT".)

### (2) Under voltage lockout protection circuit

A transient state at power-on or a momentary drop of the power supply voltage causes the control IC to malfunction, resulting in system breakdown or system deterioration. By detecting the internal reference voltage with respect to the power supply voltage, this protection circuit resets the latch circuit to turn off the output transistor and set the duty (OFF) = 100%, while at the same time holding the CSCP terminal (pin 23) at the "L". The reset is cleared when the power supply voltage becomes greater than or equal to the threshold voltage level of this protection circuit.

### (3) Output Supply Monitor Comparator (Vcc Comp.)

The output supply monitor comparator compares the output circuit power supply (VCC (O) 1, 3, VCC (O) 2, VCC (O) 4, 5, 6) to the VCC level, and operates the timer-latch short protection circuit if any of the output circuit power supplies fall below  $V_{cc} - 0.65$  V.

## METHODS OF SETTING THE OUTPUT VOLTAGE

Figure 1. CH1 to CH4

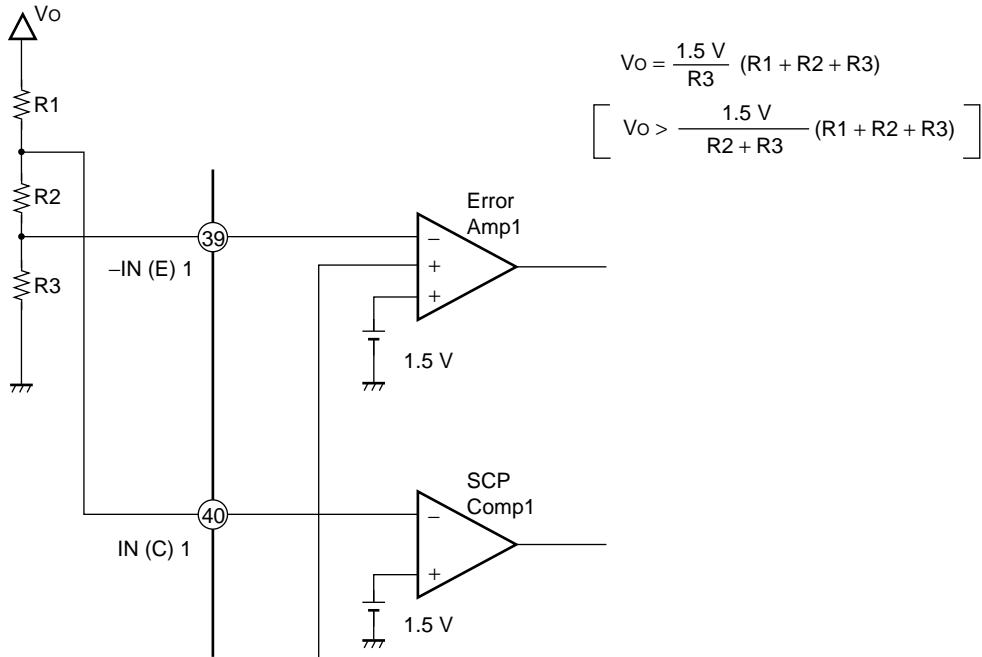
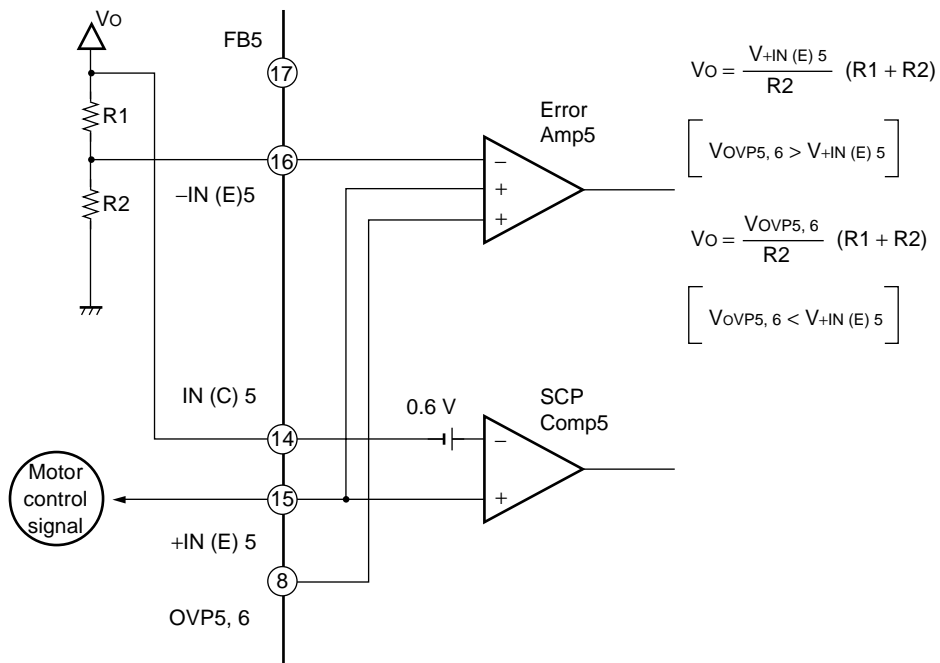


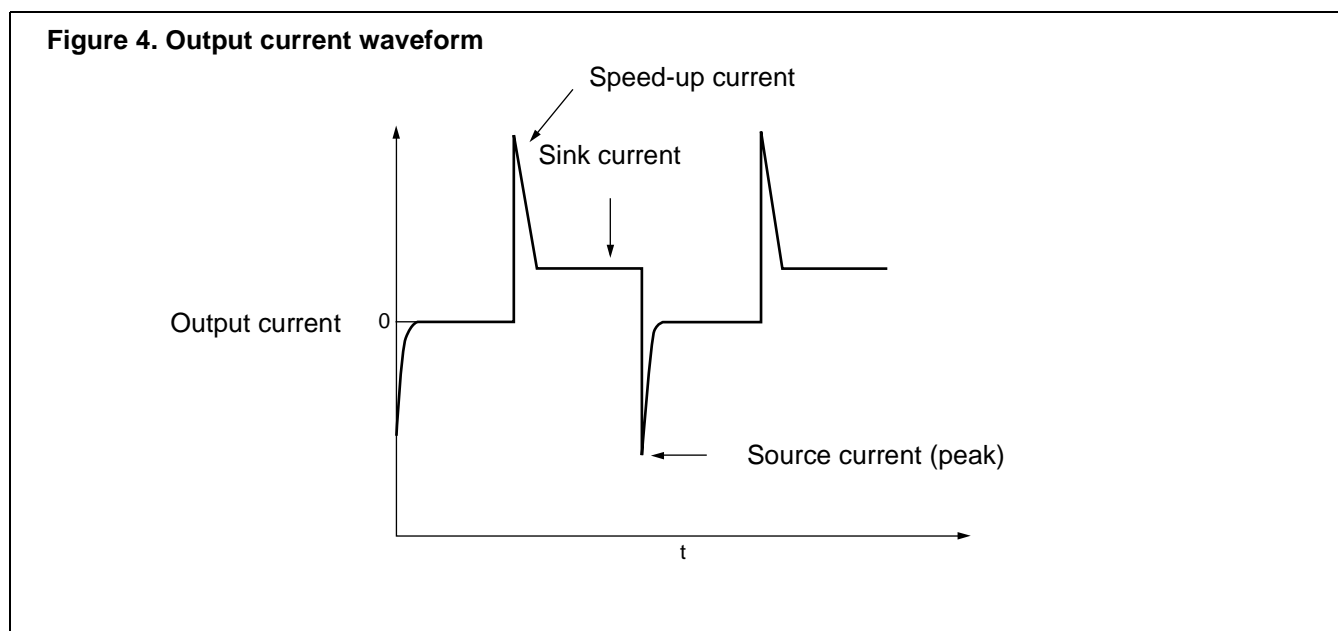
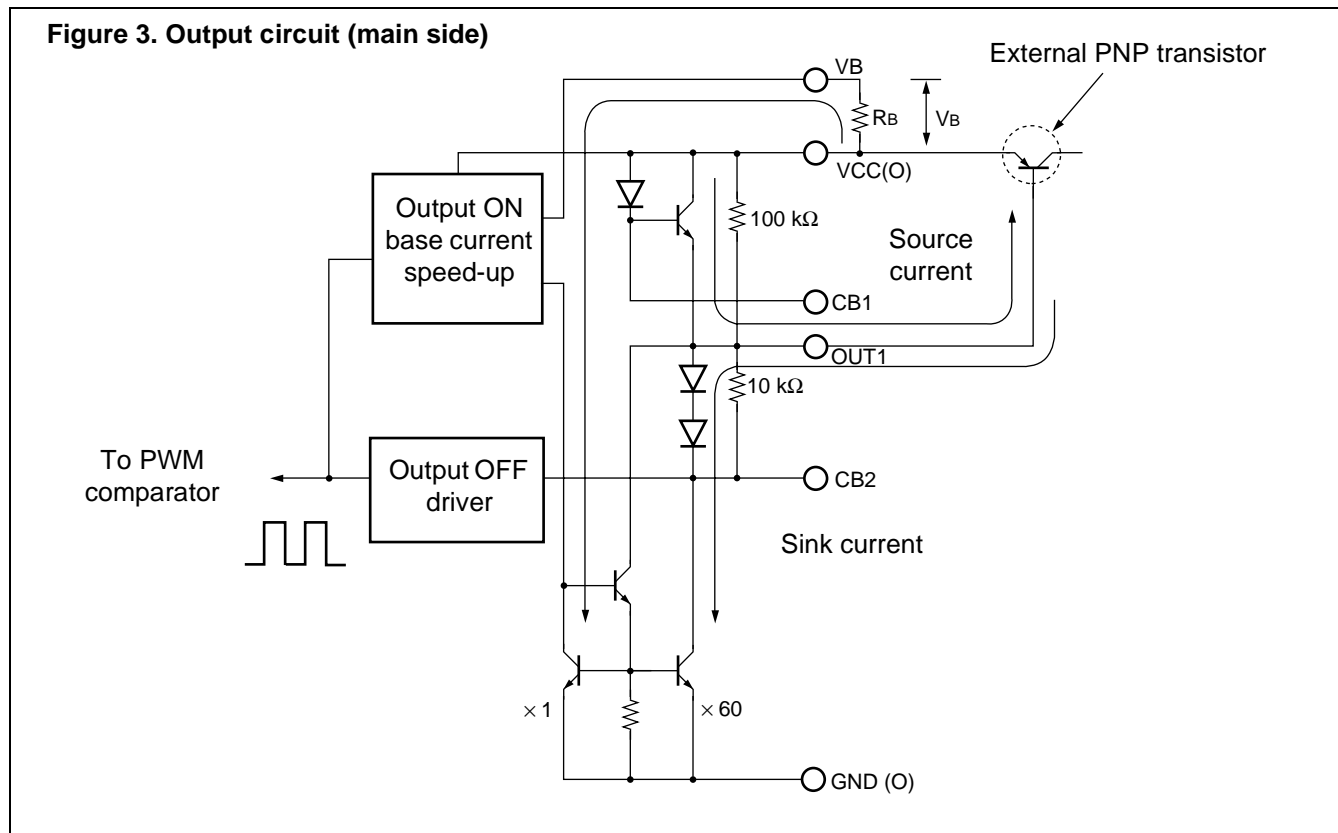
Figure 2. CH5 and CH6



## ■ METHOD OF SETTING THE OUTPUT CURRENT

Figure 3 shows the configuration of the output circuits, and Figure 4 illustrates how the sink current value of the output current waveform has a constant current setting. Note that the sink current is set by the following formula

- Sink current =  $(V_B/R_B) \times 60 \div 56/R_B$  [A]

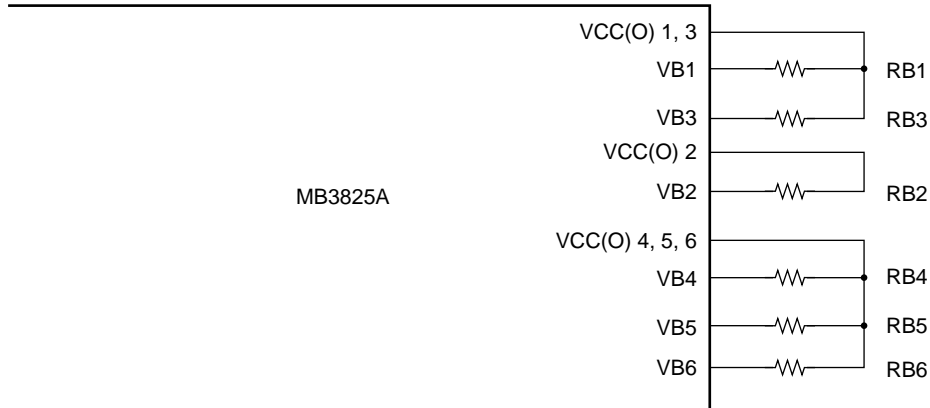


Note :

Output current setting resistance RB1 to RB6 should be connected to each channel as shown in Figure 5 below.

- For channel 1 and 3, connect the respective VB terminals to VCC (O) 1, 3 through the setting resistor RB.
- For channel 2, connect the VB2 terminal to VCC (O) 2 through setting resistor RB2.
- For channels 4 to 6, connect the respective VB terminals to VCC (O) 4, 5, 6 through setting resistor RB.

**Figure 5. Output sink current setting pin connections**



## ■ OSCILLATOR FREQUENCY SETTING

The oscillator frequency can be set by connecting a timing capacitor ( $C_T$ ) to the CT terminal (pin 22) and a timing resistor ( $R_T$ ) to the RT terminal (pin 21) .

Oscillator frequency :  $f_{osc}$

$$f_{osc} \text{ (kHz)} \doteq \frac{1950000}{C_T \text{ (pF)} \bullet R_T \text{ (k}\Omega)}$$

## METHOD OF SETTING TIME CONSTANT FOR TIMER-LATCH SHORT PROTECTION CIRCUIT

The short detection comparator (SCP comparator) in each of the channels constantly compares the error amplifier output level to the reference voltage and the SCP terminal (pin 13) .

While the switching regulator load conditions are stable on all channels, or when the voltage level at the SCP terminal is higher than the reference voltage, the short detection comparator output remains at "L" level, transistor Q3 is turned on, and the CSCP terminal (pin 23) is held at input standby voltage ( $V_{STB} \doteq 50 \text{ mV}$ ) .

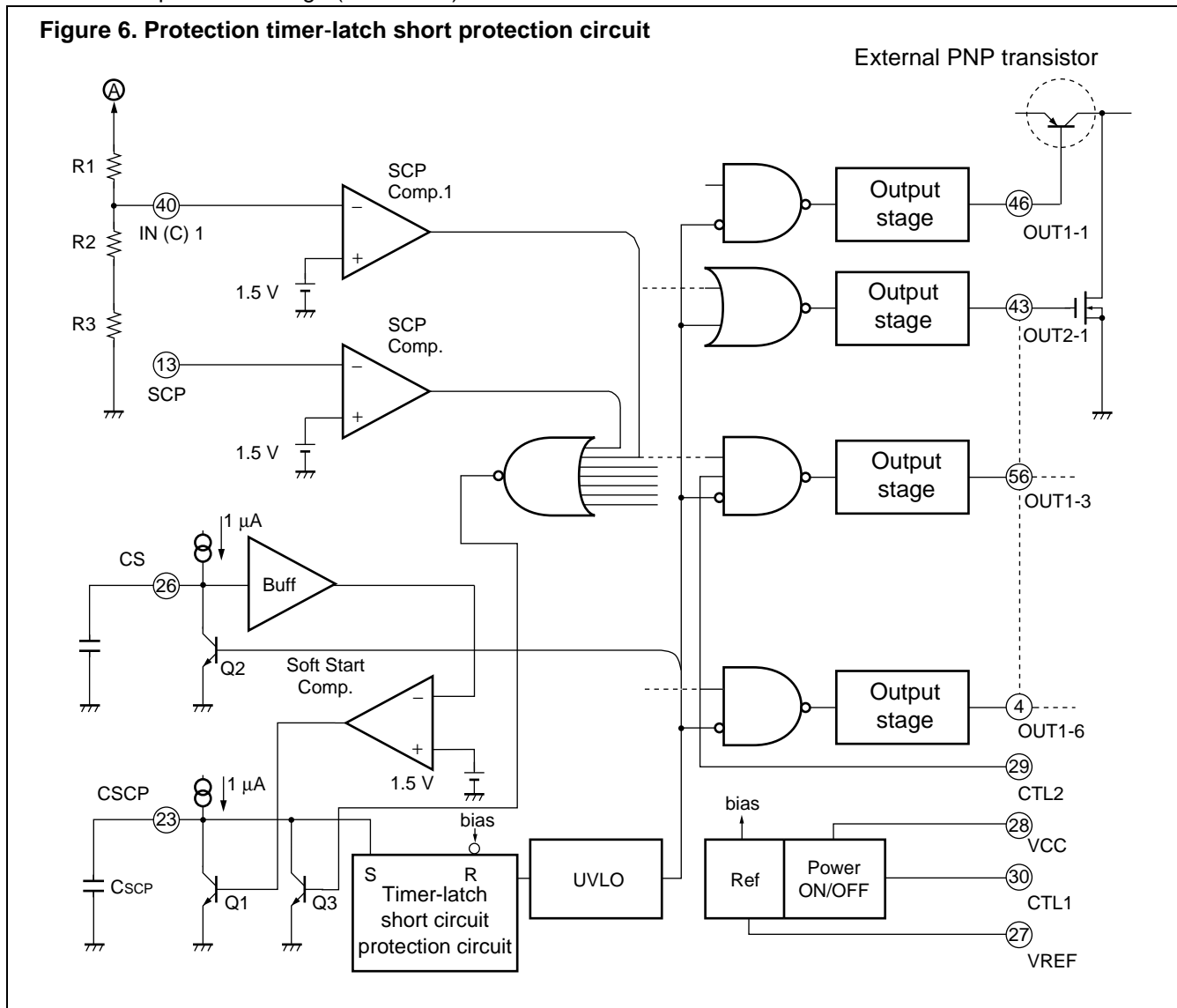
If the load conditions change rapidly due to a short-circuiting of load, causing the output voltage to drop, or if the voltage at the SCP terminal falls below the reference voltage level, the output from the short detection comparator on the corresponding channel or the input at the SCP terminal goes to "H" level. This causes transistor Q3 to turn off and the external short protection capacitor  $C_{SCP}$  connected to the CSCP terminal to charge at  $1.0 \mu\text{A}$ .

Short Detection Time ( $t_{PE}$ )

$$t_{PE} \text{ (s)} \doteq 0.7 \times C_{SCP} \text{ (\mu F)}$$

When the capacitor  $C_{SCP}$  is charged to the threshold voltage  $V_{TH} \doteq 0.7 \text{ V}$  the SR latch is set, and the external PNP is turned off (inactive interval is set to 100%) . At this point the SR latch input is closed and the  $C_{SCP}$  terminal is held at input latch voltage ( $V_I \doteq 50 \text{ mV}$ ) .

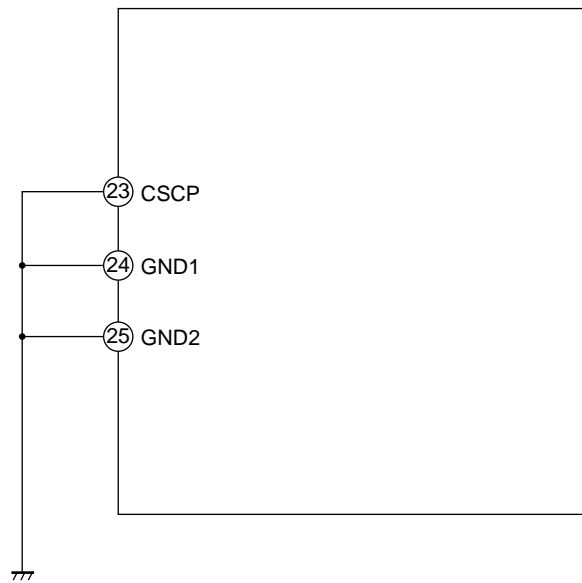
**Figure 6. Protection timer-latch short protection circuit**



## ■ TREATMENT WITHOUT USING CSCP

When you do not use the timer-latch short protection circuit, connect the CSCP terminal (pin 23) to GND with the shortest distance.

**Figure 7. Treatment when not using CSCP**





# MB3825A

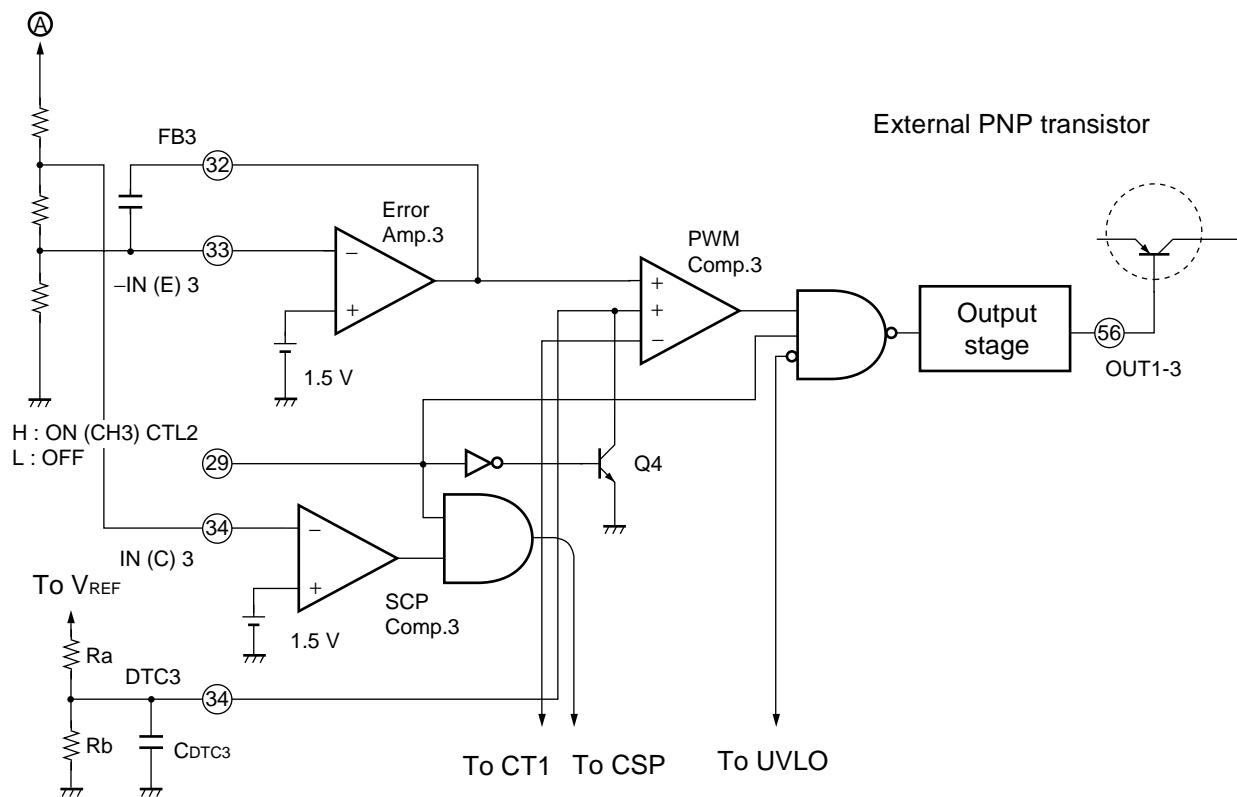
- Channel 3

The capacitor  $C_{DTC3}$  is placed between the DTC3 terminal (pin 31) and GND, so that when the CTL2 terminal (pin 29) goes from "L" to "H" level, the transistor Q4 is turned off and the output voltage is in proportion to the DTC3 terminal voltage providing the soft-start operation.

As the short detection function is not turned off during soft-start operation, this setting should be made under the following condition.

Channel 3 soft-start circuit time < Short detection time

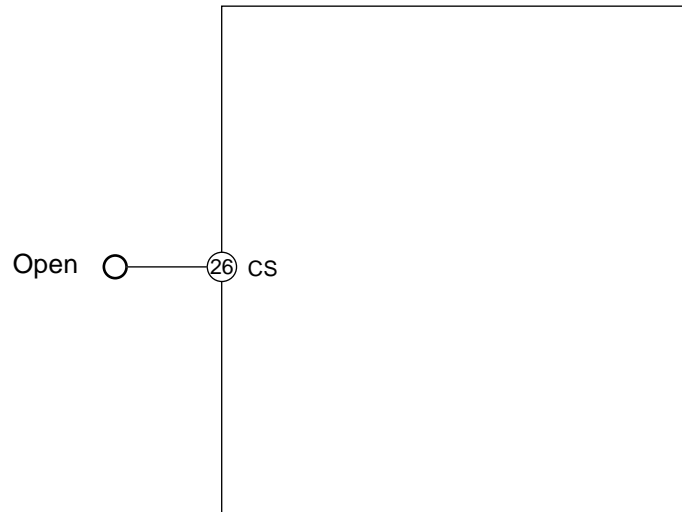
**Figure 9. Channel 3 soft-start circuit**



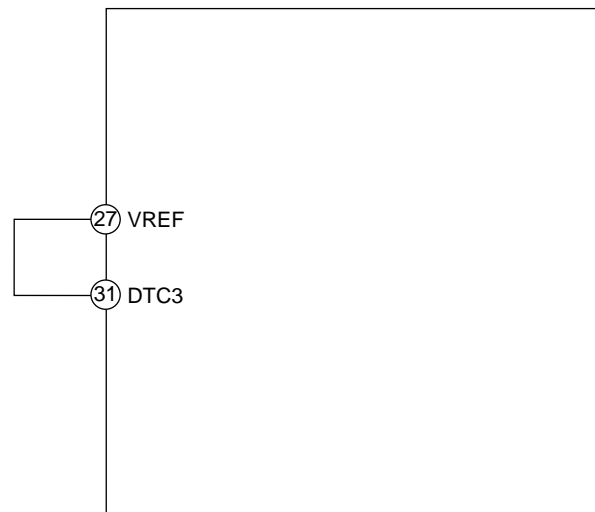
## ■ PROCESSING WITHOUT USING CS TERMINAL

If the soft-start function is not used, the CS terminal (pin 26) for channels 1, 2, and 4 should be left open. For channel 3, connect the DTC3 terminal (pin 31) to the VREF terminal (pin 27) .

**Figure 10. When no soft-start time is set (1, 2, 4 channel)**



**Figure 11. When no soft-start time is set (3 channel)**



## ■ METHOD OF SETTING THE DEAD TIME

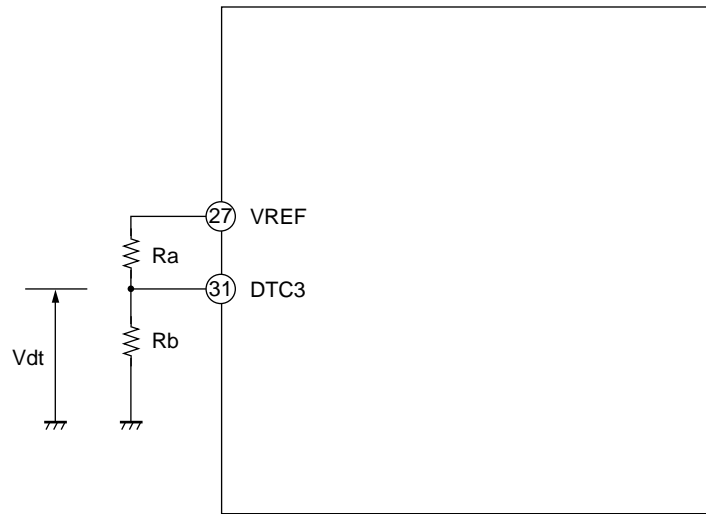
When the device is set for step-up inverted output based on the flyback method, the output transistor is fixed to full-on state (ON-duty = 100%) at power switch-on. To prevent this problem, you may determine the voltages on the DTC3 terminal (pin 31) from the  $V_{REF}$  voltage so you can easily set the output transistor's dead time (maximum ON-duty) independently for each channel as shown Figure.12.

When the voltage on the DTC3 terminal is lower than the triangular-wave (CT1) output voltage from the oscillator, the output transistor turns off. The dead time calculation formula assuming that triangular-wave amplitude  $\doteq 0.7$  V and triangular-wave maximum voltage  $\doteq 1.35$  V is given below.

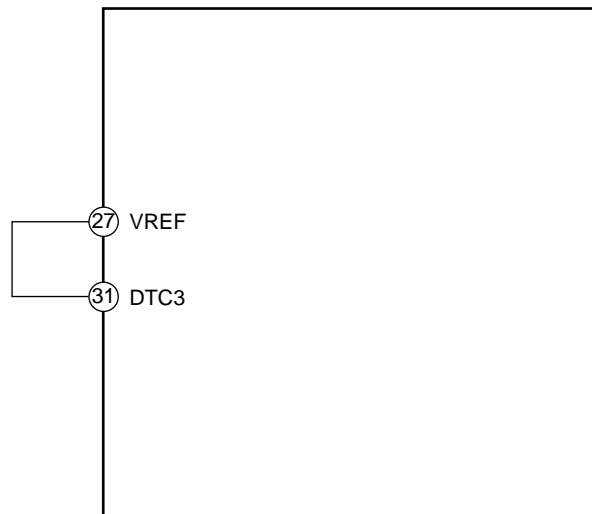
$$\text{Duty (ON)}_{\text{MAX}} \doteq \frac{V_{dt} - 0.65}{0.7} \times 100 [\%]$$

When you do not use this DTC3 terminal, connect then to  $V_{REF}$  terminal (pin 27) as shown Figure.13.

**Figure 12. When using DTC to set dead time**

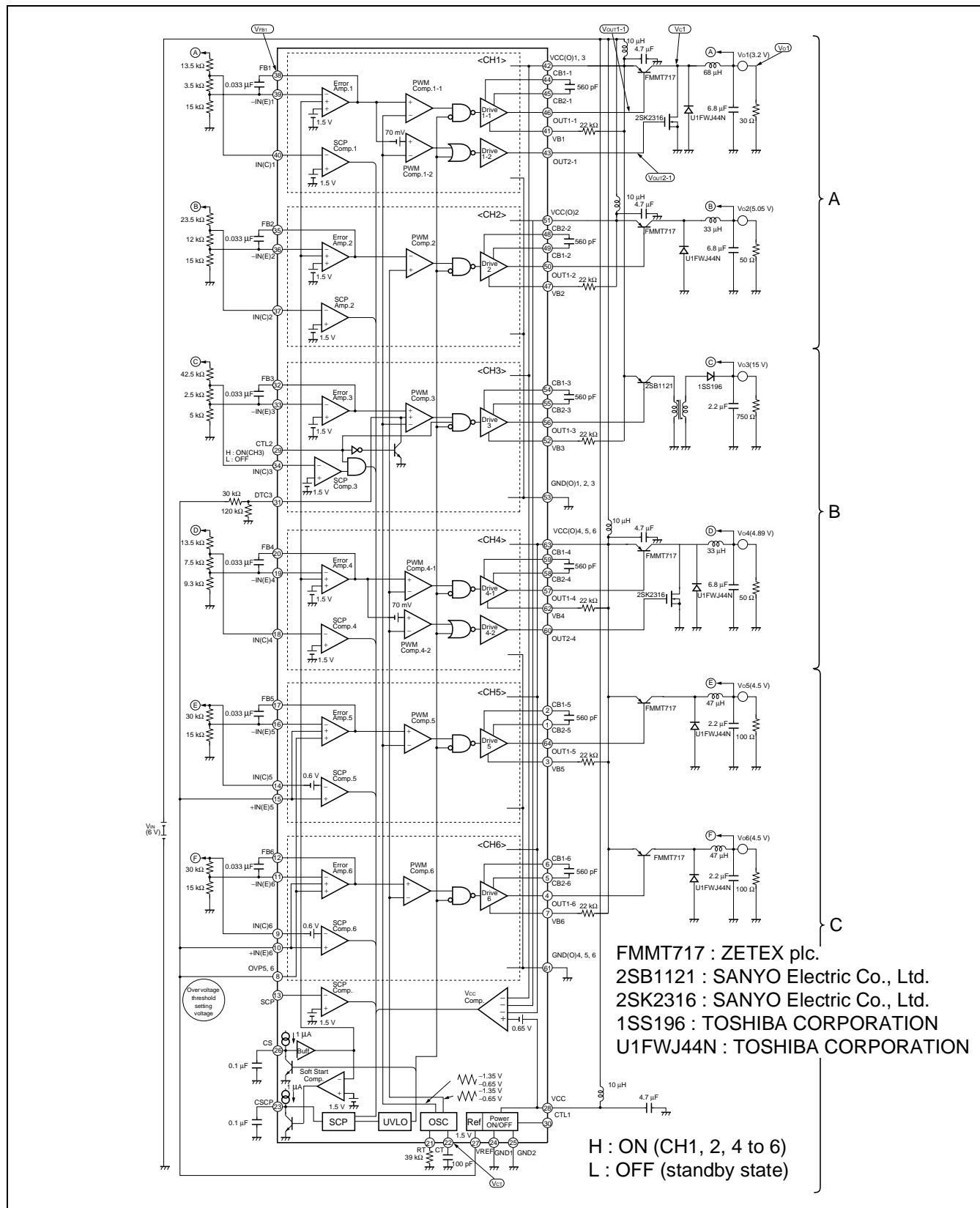


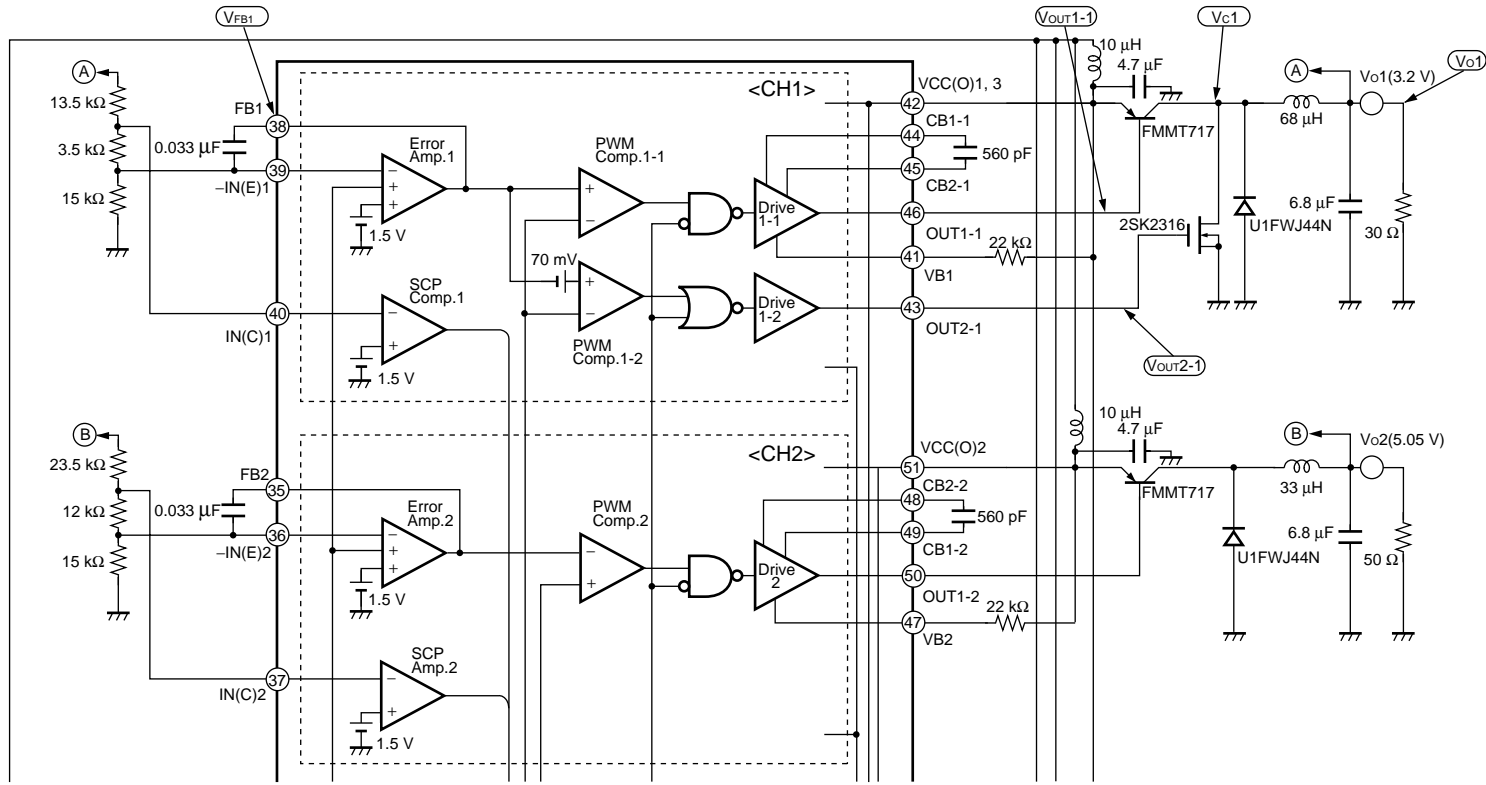
**Figure 13. When not using DTC to set dead time**



## APPLICATION EXAMPLE

### General view





FMMT717 : ZETEX plc.

2SB1121 : SANYO Electric Co., Ltd.

2SK2316 : SANYO Electric Co., Ltd.

1SS196 : TOSHIBA CORPORATION

U1FWJ44N : TOSHIBA CORPORATION

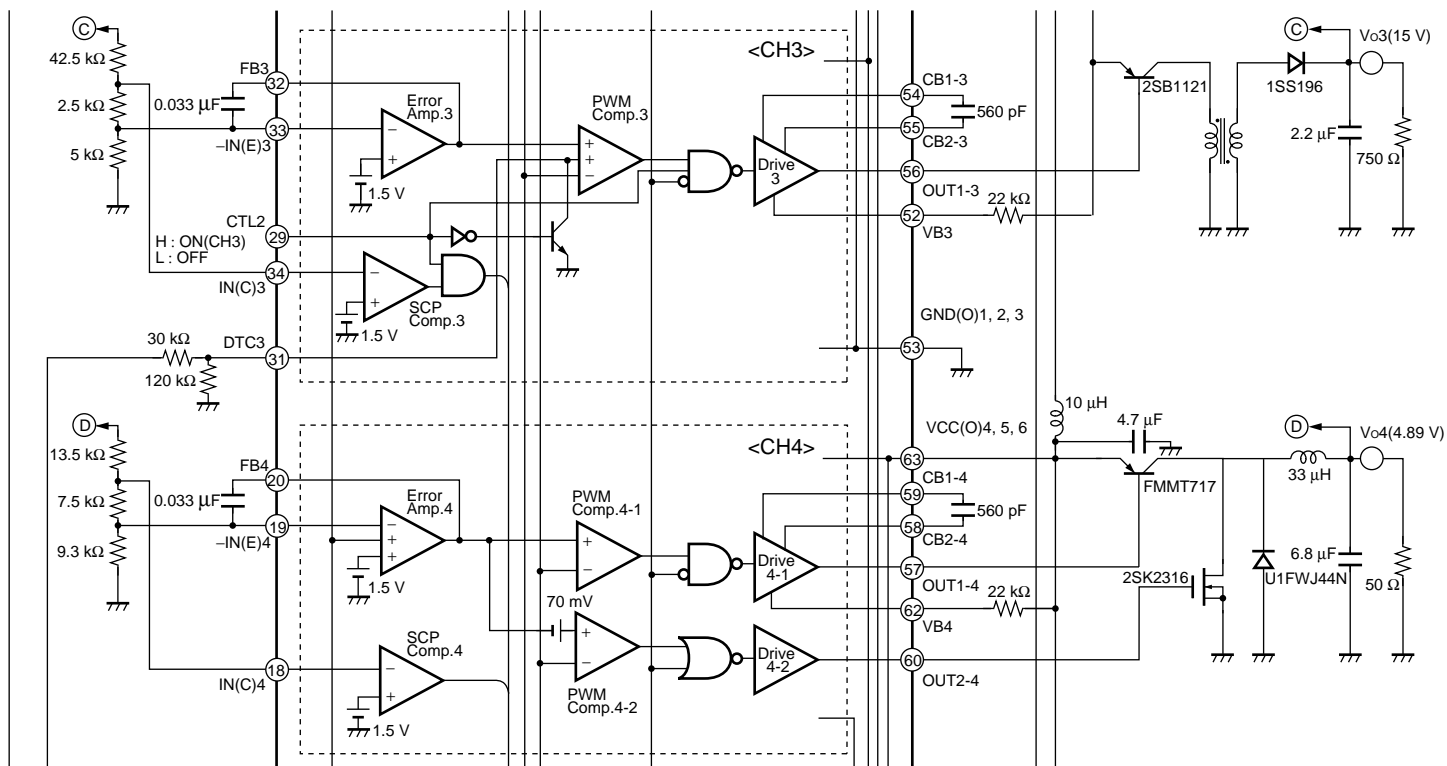
H : ON (CH1, 2, 4 to 6)

L : OFF (standby state)

• Enlarged view of A

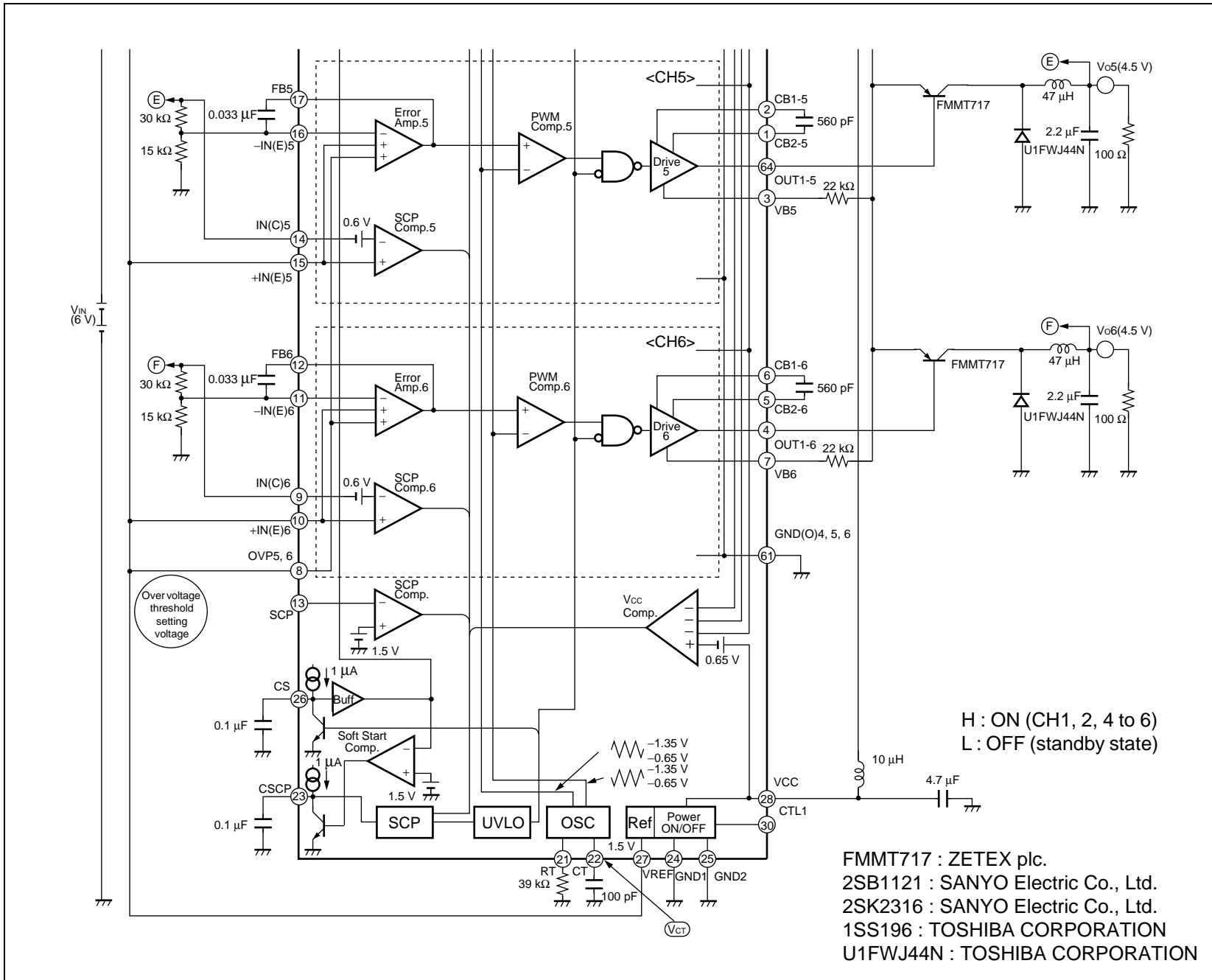
MB3825A

• Enlarged view of B



FM7T17 : ZETEX plc.  
 2SB1121 : SANYO Electric Co., Ltd.  
 2SK2316 : SANYO Electric Co., Ltd.  
 1SS196 : TOSHIBA CORPORATION  
 U1FWJ44N : TOSHIBA CORPORATION

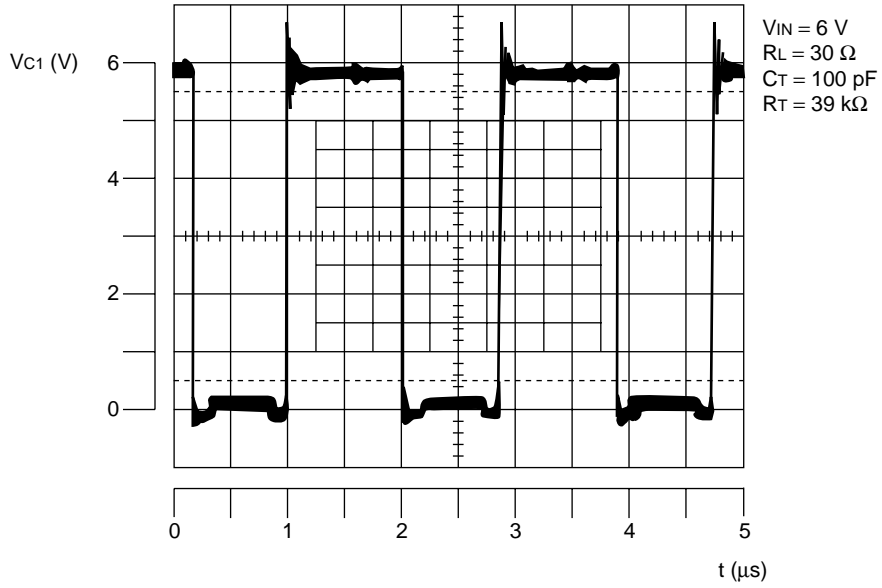
H : ON (CH1, 2, 4 to 6)  
 L : OFF (standby state)



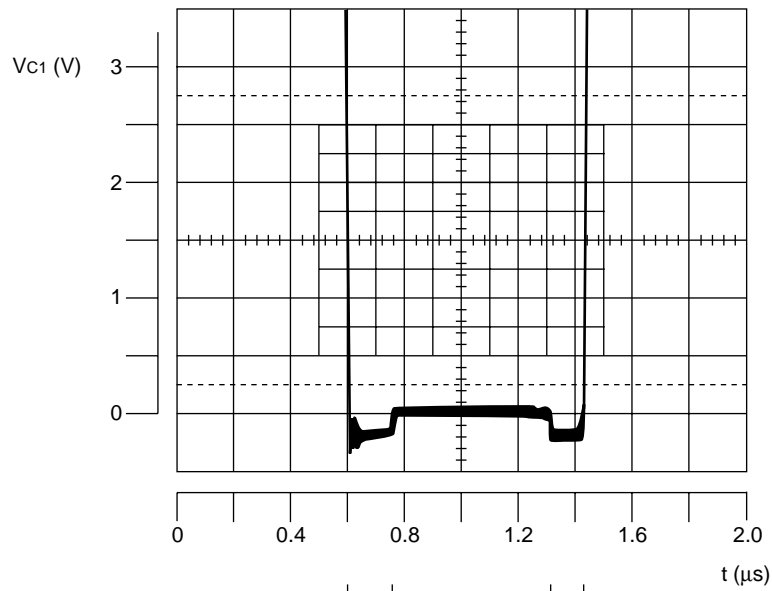
• Enlarged view of C

## REFERENCE DATA

Channel 1 switching operation waveform (operation at 500 kHz)

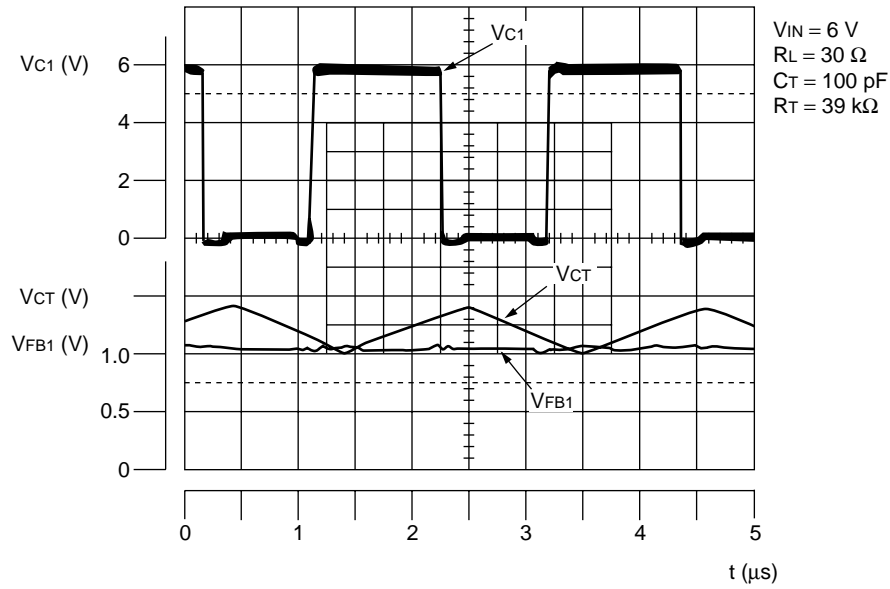


expansion

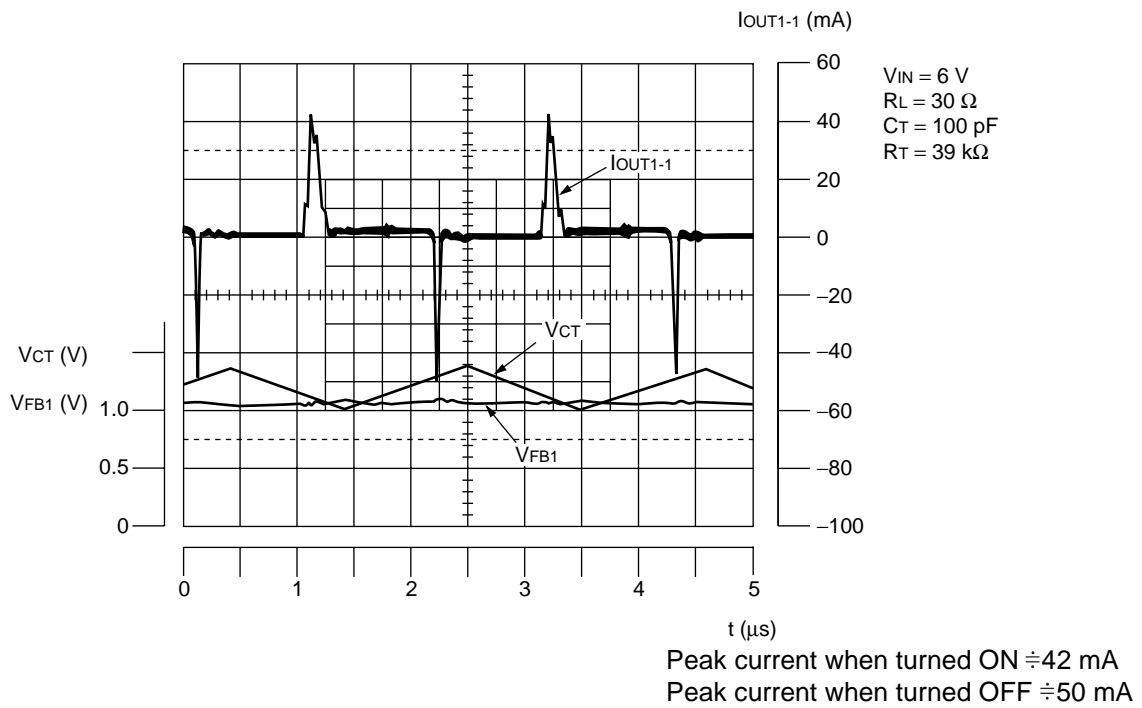


Synchronous rectifier length  $\div 150\text{ ns}$   $\div 120\text{ ns}$

**Channel 1 main side output waveform (operation at 500 kHz)**



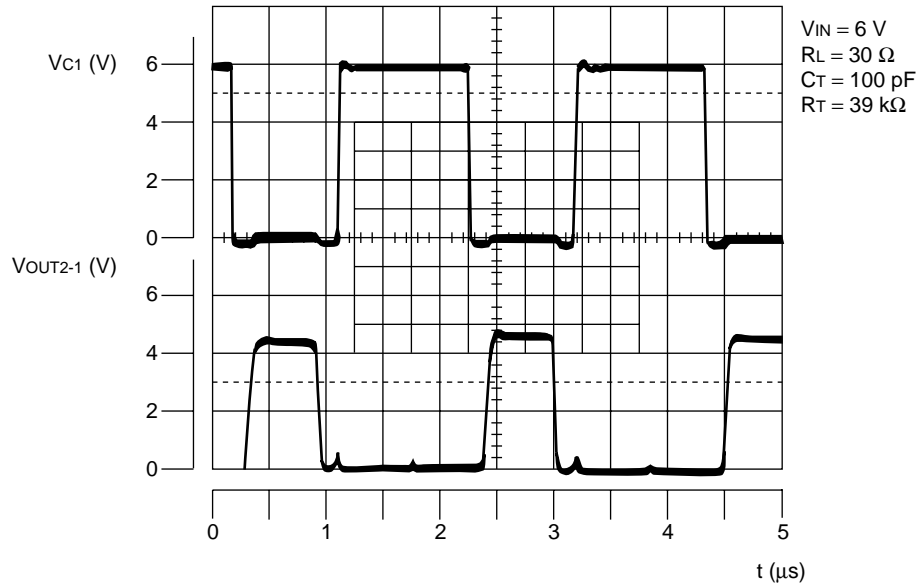
**Channel 1 main side base current waveform (operation at 500 kHz)**



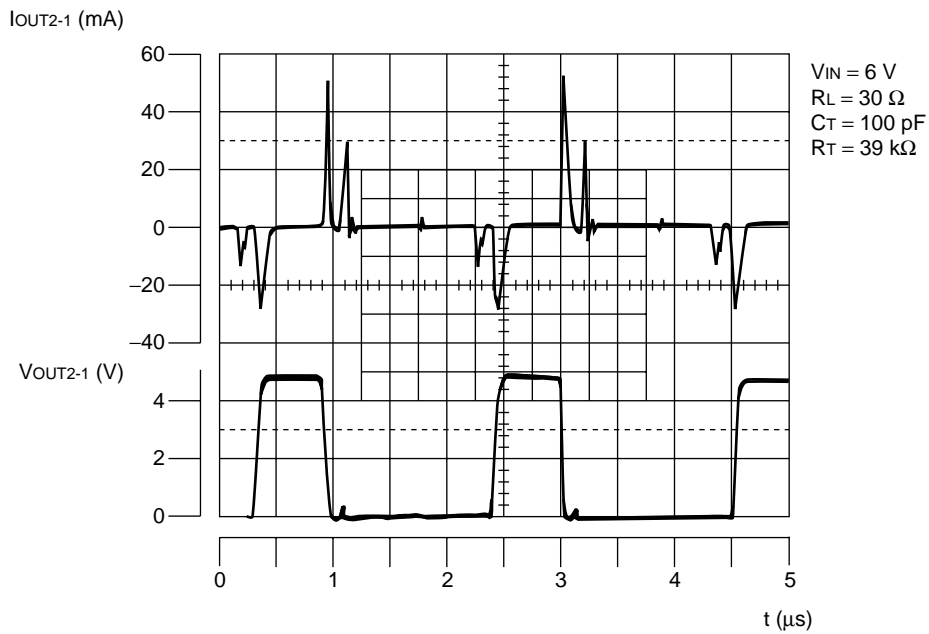
(Continued)

(Continued)

**Channel 1 synchronous rectifier side output waveform (operation at 500 kHz)**



**Channel 1 synchronous rectifier side output waveform (operation at 500 kHz)**



Output source current peak value  $\doteq 30\text{ mA}$   
 Output sink current peak value  $\doteq 52\text{ mA}$

# MB3825A

## ■ NOTES ON USE

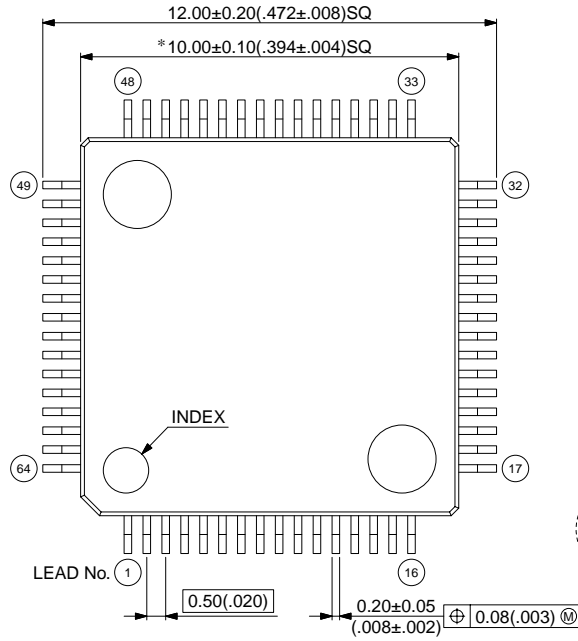
- Take account of common impedance when designing the earth line on a printed wiring board.
- Take measures against static electricity.
  - For semiconductors, use antistatic or conductive containers.
  - When storing or carrying a printed circuit board after chip mounting, put it in a conductive bag or container.
  - The work table, tools and measuring instruments must be grounded.
  - The worker must put on a grounding device containing 250 k $\Omega$  to 1 M $\Omega$  resistors in series.
- Do not apply a negative voltage
  - Applying a negative voltage of  $-0.3$  V or less to an LSI may generate a parasitic transistor, resulting in malfunction.

## ■ ORDERING INFORMATION

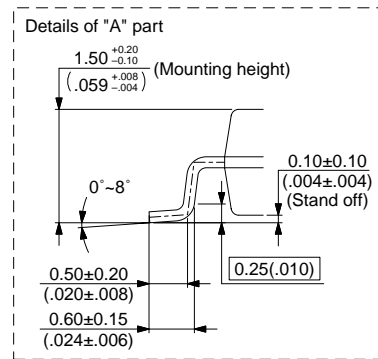
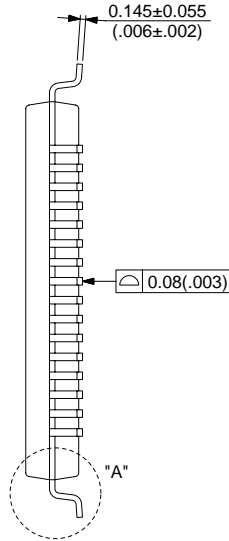
Part number	Package	Remarks
MB3825APFV	64-pin plastic LQFP (FPT-64P-M03)	
MB3825APFF	64-pin plastic LQFP (FPT-64P-M20)	

## ■ PACKAGE DIMENSION

64-pin Plastic LQFP  
(FPT-64P-M03)



Note 1)\* : These dimensions do not include resin protrusion.  
 Note 2) Pins width and pins thickness include plating thickness.  
 Note 3) Pins width do not include tie bar cutting remainder.



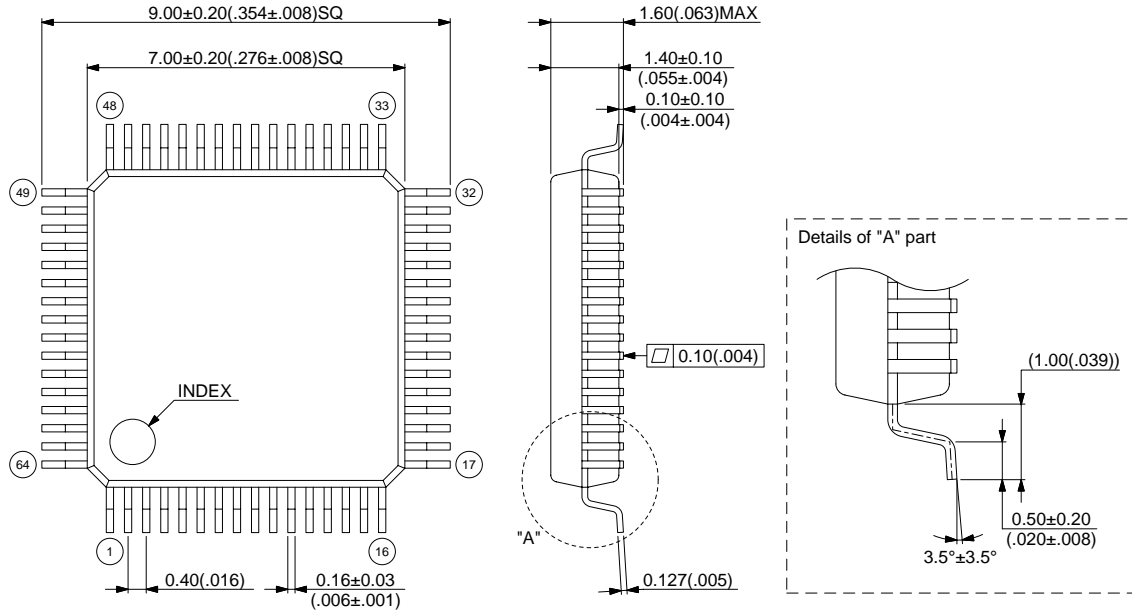
© 2003 FUJITSU LIMITED F64009S-c-5-8

Dimensions in mm (inches) .

Note : The values in parentheses are reference values.

# MB3825A

64-pin Plastic LQFP  
(FPT-64P-M20)



© 2000 FUJITSU LIMITED F64031S-1c-1

Dimensions in mm (inches) .

Note : The values in parentheses are reference values.

**MEMO**

# FUJITSU MICROELECTRONICS LIMITED

Shinjuku Dai-Ichi Seimei Bldg. 7-1, Nishishinjuku 2-chome, Shinjuku-ku,  
Tokyo 163-0722, Japan Tel: +81-3-5322-3347 Fax: +81-3-5322-3387  
<http://jp.fujitsu.com/fml/en/>

*For further information please contact:*

## **North and South America**

FUJITSU MICROELECTRONICS AMERICA, INC.  
1250 E. Arques Avenue, M/S 333  
Sunnyvale, CA 94085-5401, U.S.A.  
Tel: +1-408-737-5600 Fax: +1-408-737-5999  
<http://www.fma.fujitsu.com/>

## **Europe**

FUJITSU MICROELECTRONICS EUROPE GmbH  
Pittlerstrasse 47, 63225 Langen,  
Germany  
Tel: +49-6103-690-0 Fax: +49-6103-690-122  
<http://emea.fujitsu.com/microelectronics/>

## **Korea**

FUJITSU MICROELECTRONICS KOREA LTD.  
206 KOSMO TOWER, 1002 Daechi-Dong,  
Kangnam-Gu, Seoul 135-280  
Korea  
Tel: +82-2-3484-7100 Fax: +82-2-3484-7111  
<http://www.fmk.fujitsu.com/>

## **Asia Pacific**

FUJITSU MICROELECTRONICS ASIA PTE LTD.  
151 Lorong Chuan, #05-08 New Tech Park,  
Singapore 556741  
Tel: +65-6281-0770 Fax: +65-6281-0220  
<http://www.fujitsu.com/sg/services/micro/semiconductor/>

FUJITSU MICROELECTRONICS SHANGHAI CO., LTD.  
Rm.3102, Bund Center, No.222 Yan An Road(E),  
Shanghai 200002, China  
Tel: +86-21-6335-1560 Fax: +86-21-6335-1605  
<http://cn.fujitsu.com/fmc/>

FUJITSU MICROELECTRONICS PACIFIC ASIA LTD.  
10/F., World Commerce Centre, 11 Canton Road  
Tsimshatsui, Kowloon  
Hong Kong  
Tel: +852-2377-0226 Fax: +852-2376-3269  
<http://cn.fujitsu.com/fmc/tw>

All Rights Reserved.

The contents of this document are subject to change without notice.

Customers are advised to consult with sales representatives before ordering.

The information, such as descriptions of function and application circuit examples, in this document are presented solely for the purpose of reference to show examples of operations and uses of FUJITSU MICROELECTRONICS device; FUJITSU MICROELECTRONICS does not warrant proper operation of the device with respect to use based on such information. When you develop equipment incorporating the device based on such information, you must assume any responsibility arising out of such use of the information.

FUJITSU MICROELECTRONICS assumes no liability for any damages whatsoever arising out of the use of the information.

Any information in this document, including descriptions of function and schematic diagrams, shall not be construed as license of the use or exercise of any intellectual property right, such as patent right or copyright, or any other right of FUJITSU MICROELECTRONICS or any third party or does FUJITSU MICROELECTRONICS warrant non-infringement of any third-party's intellectual property right or other right by using such information. FUJITSU MICROELECTRONICS assumes no liability for any infringement of the intellectual property rights or other rights of third parties which would result from the use of information contained herein.

The products described in this document are designed, developed and manufactured as contemplated for general use, including without limitation, ordinary industrial use, general office use, personal use, and household use, but are not designed, developed and manufactured as contemplated (1) for use accompanying fatal risks or dangers that, unless extremely high safety is secured, could have a serious effect to the public, and could lead directly to death, personal injury, severe physical damage or other loss (i.e., nuclear reaction control in nuclear facility, aircraft flight control, air traffic control, mass transport control, medical life support system, missile launch control in weapon system), or (2) for use requiring extremely high reliability (i.e., submersible repeater and artificial satellite).

Please note that FUJITSU MICROELECTRONICS will not be liable against you and/or any third party for any claims or damages arising in connection with above-mentioned uses of the products.

Any semiconductor devices have an inherent chance of failure. You must protect against injury, damage or loss from such failures by incorporating safety design measures into your facility and equipment such as redundancy, fire protection, and prevention of over-current levels and other abnormal operating conditions.

Exportation/release of any products described in this document may require necessary procedures in accordance with the regulations of the Foreign Exchange and Foreign Trade Control Law of Japan and/or US export control laws.

The company names and brand names herein are the trademarks or registered trademarks of their respective owners.