

Linear IC Converter

CMOS

D/A Converter for Digital Tuning (12-channel, 8-bit, on-chip OP amp., low-voltage)

MB88146A

■ DESCRIPTION

The MB88146A is an 8-bit D/A converter with twelve built-in channels. The 12 analog outputs each have a built-in OP amplifier with large current drive-capability.

The data input/output format is CS (chip select) with serial bus connection available.

A built-in 12-bit I/O expander enables serial ↔ parallel conversion (8 of the 12 bits can also be used for analog output).

This product can be used for microcontroller port expansion, electronic level adjustment, replacement of semi-fixed resistance for tuning, etc.

■ FEATURES

- Ultra low power consumption (1.2 mW/chl: typical)
- Ultra compact package
- Built-in 12-channel R-2R type 8-bit D/A converter
- Built-in 12-bit I/O expander (8 bits also function as analog output)
- Built-in analog output amplifier (sink current 1.0 mA maximum, source current 1.0 mA maximum)
- Built-in power-on detection circuit (initialized at detection of VccD power-on)
- MCU interface compatible with 3 V to 5 V systems
- Power divided into MCU interface power supply (VccD) and OP amplifier power supply (VccA), D/A converter power supply (VccD)
- Analog output capability from 0 V to VccA
- Serial data I/O operates to maximum of 2.5 MHz (in cascade connection, up to 2.5 MHz when VccD = 5 V, up to 1.5 MHz when VccD = 3 V)
- CMOS process
- Choice of two packages: SDIP-24 pin and SSOP-24 pin.

MB88146A

■ PACKAGES

24-pin Plastic DIP

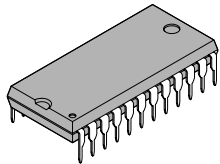

(DIP-24P-M02)

24-pin Plastic SSOP

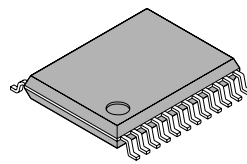

(FPT-24P-M03)

■ PIN ASSIGNMENT

(TOP VIEW)

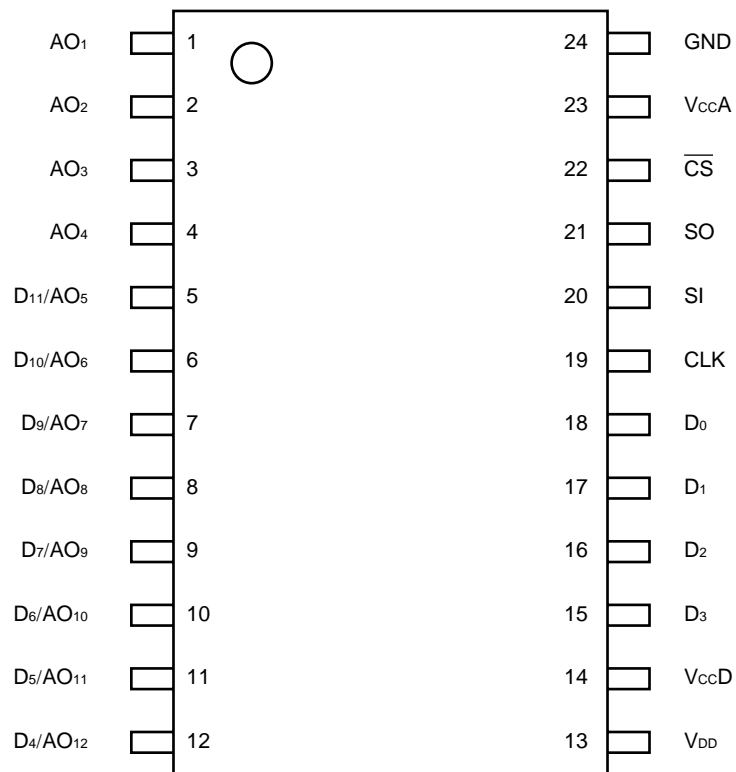

DIP-24, SSOP-24

■ PIN DESCRIPTION

Pin no.	Pin name	Description
1 to 4	AO ₁ to AO ₄	D/A converter analog output pins (V _{DD} to GND output). (Default: output #00 setting level)
5 to 12	D ₁₁ /AO ₅ to D ₄ /AO ₁₂	These pins may be used either as I/O expander parallel input/output (V _{CC} A/ GND output 0.5 V _{CC} A/0.2 V _{CC} A input) or D/A converter analog output (V _{DD} to GND output). Pin status is controlled by input data. See "■Data Configuration". (Default: Input mode, Hi-Z state)
13	V _{DD} *1	D/A converter reference power pin.
14	V _{CC} D*1	MCU interface power supply pin (power supply for I/O expander).
15 to 18	D ₃ to D ₀	I/O expander parallel input/output pins. (V _{CC} D/GND output: When V _{CC} D ≥ 4.0 V, 0.5 V _{CC} D/0.2 V _{CC} D input, When V _{CC} D < 4.0 V, 2 V/0.2 V _{CC} D input) Pin status is controlled by input data. See "■Data Configuration." (Default: Input mode, Hi-Z state)
19	CLK*2	Shift clock signal input pin. When \overline{CS} = "L," SI data is loaded into the shift register at the rising edge of the shift clock.
20	SI*2	Data input pin (serial input pin). Used for 16-bit serial data input.
21	SO	Data output pin (serial output pin). The first bit (LSB) data of the 16-bit shift register is output simultaneously with the falling edge of the shift clock. When \overline{CS} output = "H," this pin goes to high impedance state.
22	\overline{CS} *2	Chip select signal input pin. Input to shift registers is enabled when the \overline{CS} signal falling edges. Shift register contents can be executed when the \overline{CS} signal rising edges.
23	V _{CC} A*1	Analog unit power supply pin (OP amplifier power supply).
24	GND	Common GND pin.

*1: Be sure that V_{CC}A ≥ V_{CC}D, and that V_{CC}A ≥ V_{DD}.

*2: Do not leave this pin in floating state.

MB88146A

■ BLOCK DIAGRAM

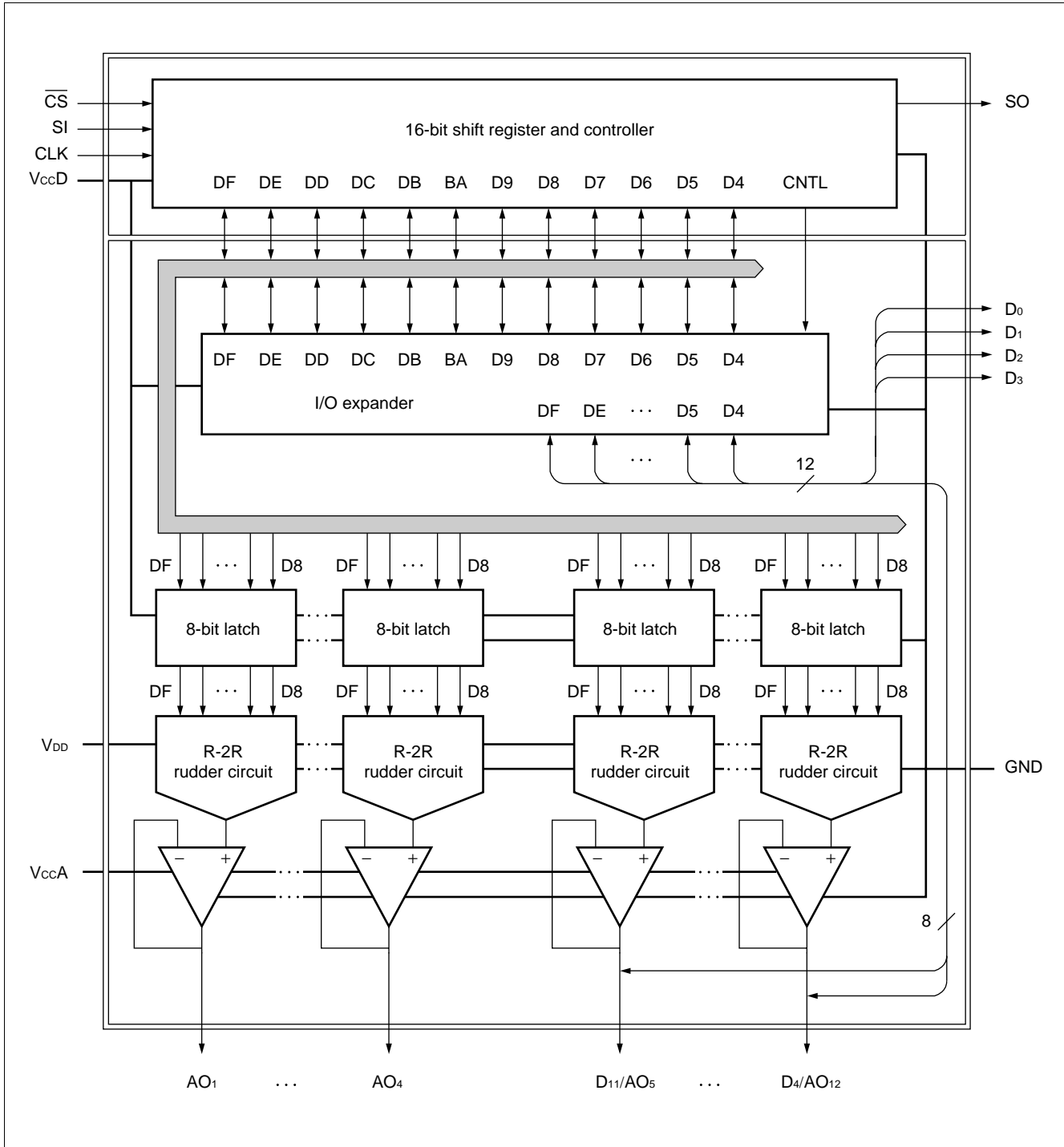

■ DATA CONFIGURATION

1. Data Configuration

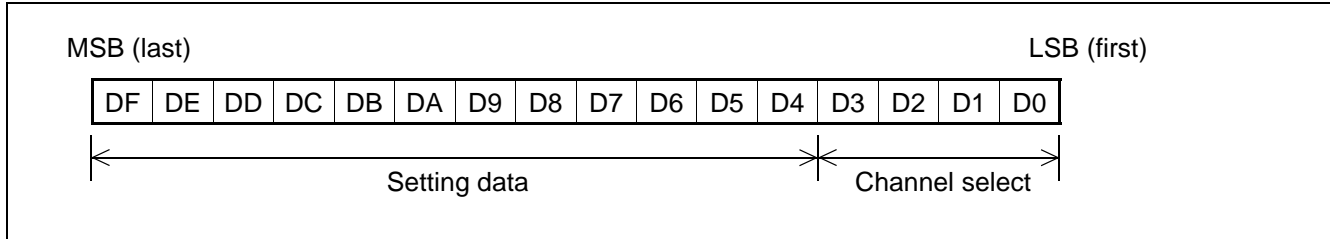

2. Channel Select

D3	D2	D1	D0	Function
0	0	0	0	Don't Care/special function
0	0	0	1	AO ₁ selected
0	0	1	0	AO ₂ selected
to	to	to	to	to
1	0	1	1	AO ₁₁ selected
1	1	0	0	AO ₁₂ selected
1	1	0	1	I/O expander (serial → parallel)
1	1	1	0	I/O expander (parallel → serial)
1	1	1	1	Expander status register (ESR)

MB88146A

3. Setting Data

- Don't Care/special function (Channel select = "0000")

DF	DE	DD	DC	DB	DA	D9	D8	D7	D6	D5	D4	Analog output voltage level
×	×	×	×	×	×	×	×	0	0	0	0	Don't Care
to	to	to	to	to	to	to	to	to	to	to	to	Don't Care
×	×	×	×	×	×	×	×	1	0	1	1	Don't Care
0	0	0	0	0	0	0	0	1	1	0	0	GND (all channels)
0	0	0	0	0	0	0	1	1	1	0	0	$V_{DD}/256 \times 1$ (all channels)
0	0	0	0	0	0	1	0	1	1	0	0	$V_{DD}/256 \times 2$ (all channels)
to	to	to	to	to	to	to	to	to	to	to	to	to
1	1	1	1	1	1	1	0	1	1	0	0	$V_{DD}/256 \times 254$ (all channels)
1	1	1	1	1	1	1	1	1	1	0	0	$V_{DD}/256 \times 255$ (all channels)
×	×	×	×	×	×	×	×	1	1	0	1	Hi-Z (I/O expander state)*
×	×	×	×	×	×	×	×	1	1	1	0	Reset (state when power is ON)
×	×	×	×	×	×	×	×	1	1	1	1	Don't Care

×: Don't care * : Hi-Z output on all channels of AO₅ through AO₁₂

- D/A Converter (Channel select = "0001" to "1100")

DF	DE	DD	DC	DB	DA	D9	D8	D7	D6	D5	D4	Analog output voltage level
0	0	0	0	0	0	0	0	0	0	0	0	GND
0	0	0	0	0	0	0	1	0	0	0	0	$V_{DD}/256 \times 1$
0	0	0	0	0	0	1	0	0	0	0	0	$V_{DD}/256 \times 2$
0	0	0	0	0	0	1	1	0	0	0	0	$V_{DD}/256 \times 3$
to	to	to	to	to	to	to	to	to	to	to	to	to
1	1	1	1	1	1	0	1	0	0	0	0	$V_{DD}/256 \times 253$
1	1	1	1	1	1	1	0	0	0	0	0	$V_{DD}/256 \times 254$
1	1	1	1	1	1	1	1	0	0	0	0	$V_{DD}/256 \times 255$
×	×	×	×	×	×	×	×	0	0	0	1	Hi-Z (I/O expander state)*
×	×	×	×	×	×	×	×	0	0	1	0	Don't Care
to	to	to	to	to	to	to	to	to	to	to	to	Don't Care
×	×	×	×	×	×	×	×	1	1	1	1	Don't Care

×: Don't care * : Only AO₅ through AO₁₂ output is valid

- I/O Expander [Channel select = "1101"]: Serial → Parallel Conversion

Performs parallel conversion of data bits D4 to DF for output on pins D₀ to D₁₁.

Note that only those pins designated for output in the ESR (expander status register) are output.

Shift register

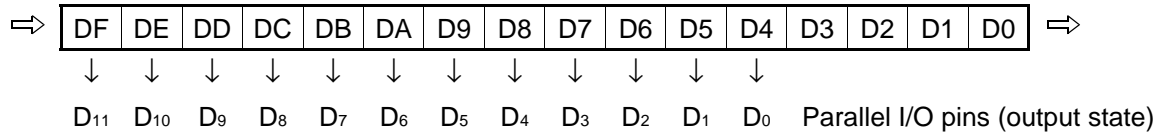

- I/O Expander [Channel select = "1110"]: Parallel → Serial Conversion

Writes data from D₀ to D₁₁ pins to bits D4 to DF in the shift register.

Data is output to the SO pin on the shift clock (CLK) signal (The first 4 bits output data D₀ to D₃, so the converted output should be read as data bits 5 through 16.).

Note that the data value is "0" for pins designated for output in the ESR (expander status register) as well as analog output pins.

Shift register

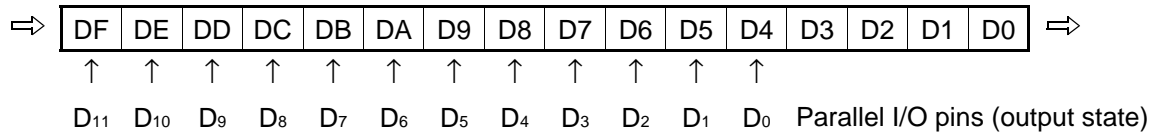

- Expander Status Register [Channel select = "1111"]

Shift register

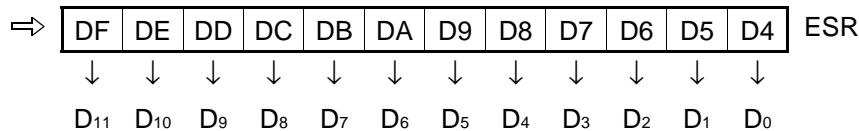

This register sets the status of each pin.

Setting	Pin status
"0"	<ul style="list-style-type: none"> • Input standby status (Hi-Z output) • D₁₁ to D₄ pins used for analog output should be set to "0."
"1"	<ul style="list-style-type: none"> • Output state

MB88146A

Note: After power V_{CCD} is turned on, the state of pins and registers is as follows.

Pin	State
AO ₁ to AO ₄	"L" output
D ₁₁ /AO ₅ to D ₄ /AO ₁₂	Hi-Z state (input state)
D ₃ to D ₀	Hi-Z state (input state)

Register	State
Shift register	Bits DF to D8 are "0," and D7 to D0 are not defined (retain prior state).
D/A register	All reset to "0."
Parallel output register	Not defined (retain prior state).
Expander status register (ESR)	All reset to "0."

- ESR settings have priority in determining pin states. Switching between input standby state and analog output state is enabled even when the ESR value is "1." When the ESR value returns to "0", the pin returns to its previously defined state.
- In input standby state with AO set for Hi-Z output, the AO output setting can be used for transition to AO output state.

■ ABSOLUTE MAXIMUM RATINGS

Parameter	Symbol	Conditions	Rating		Unit	
			Min.	Max.		
Power supply voltage	V _{CC} A	Based on GND (T _a = +25°C)	-0.3	+7.0	V	
	V _{CC} D		-0.3	V _{CC} A*	V	
	V _{DD}		-0.3	V _{CC} A*	V	
Input voltage 1	V _{in1}	SI, CLK, \overline{CS} , SO, D ₀ to D ₃	-0.3	V _{CC} D + 0.3	V	
Output voltage 1	V _{out1}		-0.3	V _{CC} D + 0.3	V	
Input voltage 2	V _{in2}		D ₄ to D ₁₁	-0.3	V _{CC} A + 0.3	V
Output voltage 2	V _{out2}			-0.3	V _{CC} A + 0.3	V
Power consumption	P _D	—	—	250	mW	
Operating temperature	T _a	—	-20	+85	°C	
Storage temperature	T _{stg}	—	-55	+150	°C	

* : V_{CC}A ≥ V_{CC}D, V_{CC}A ≥ V_{DD}

WARNING: Semiconductor devices can be permanently damaged by application of stress (voltage, current, temperature, etc.) in excess of absolute maximum ratings. Do not exceed these ratings.

■ RECOMMENDED OPERATING CONDITIONS

Parameter	Symbol	Conditions	Value			Unit
			Min.	Typ.	Max.	
Power supply voltage	V _{CC} A	—	4.5	5.0	5.5	V
	V _{CC} D	V _{CC} A ≥ V _{CC} D	2.7	—	V _{CC} A	V
	V _{DD}	V _{CC} A ≥ V _{DD}	2.0	—	V _{CC} A	V
	GND	—	—	0	—	V
Analog output current	I _{AL}	Source current	—	—	1.0	mA
	I _{AH}	Sink current	—	—	1.0	mA
Oscillation limit output capacity	C _{OL}	—	—	—	1.0	μF
Operation temperature	T _a	—	-20	—	+85	°C

WARNING: Recommended operating conditions are normal operating ranges for the semiconductor device. All the device's electrical characteristics are warranted when operated within these ranges.

Always use semiconductor devices within the recommended operating conditions. Operation outside these ranges may adversely affect reliability and could result in device failure.

No warranty is made with respect to uses, operating conditions, or combinations not represented on the data sheet. Users considering application outside the listed conditions are advised to contact their representative beforehand.

MB88146A

■ ELECTRICAL CHARACTERISTIC

1. DC Characteristics

(1) Digital section

($V_{CCD} \cong V_{CCA}$, $T_a = -20^{\circ}\text{C}$ to $+85^{\circ}\text{C}$)

Parameter	Symbol	Pin name	Conditions	Value			Unit
				Min.	Typ.	Max.	
Power supply voltage	V_{CCD}	V_{CCD}	—	2.7	5.0	5.5	V
Power supply current	I_{CCD}		CLK = 1 MHz, (Unloaded)	—	0.2	0.5	mA
Standby current	I_{CCS}		CLK, SI, \overline{CS} Stop $V_{in} = V_{CCD}$ or GND	-10	—	+10	μA
Input leak current	I_{ILK1}	CLK, SI, \overline{CS} , D ₀ to D ₃	$V_{in} = 0$ to V_{CCD}	-10	—	+10	μA
"H" level input voltage	V_{IH1}		$V_{CCD} \cong 4.0\text{ V}$	$0.5 \times V_{CCD}$	—	—	V
"L" level input voltage	V_{IL1}		$V_{CCD} < 4.0\text{ V}$	2.0	—	—	V
High-impedance leak current	I_{OLK}	SO	$V_{in} = 0$ to V_{CCD}	-10	—	+10	μA
"H" level output voltage	V_{OH1}	SO, D ₀ to D ₃	$I_{OH} = -0.4\text{ mA}$	$V_{CCD} - 0.4$	—	—	V
"L" level output voltage	V_{OL1}		$I_{OL} = 2.5\text{ mA}$	—	—	0.4	V

(2) D/A converter section

($V_{CCA} = 5\text{ V} \pm 10\%$, $T_a = -20^{\circ}\text{C}$ to $+85^{\circ}\text{C}$)

Parameter	Symbol	Pin name	Conditions	Value			Unit
				Min.	Typ.	Max.	
Power supply voltage	V_{DD}	V_{DD}	$V_{DD} \cong V_{CCA}$	2.0	5.0	5.5	V
Power supply current	I_{DD}		$V_{DD} \cong V_{CCA}$	—	1.2	2.5	mA
Resolution	Res	AO ₁ to AO ₁₂	Unload	—	8	—	bits
Monotonic increase	Rem		$V_{DD} = V_{CCA} - 0.1\text{ V}$	—	8	—	bits
Nonlinearity error	LE		Digital value: #06 to #FF	-1.5	—	+1.5	LSB
Differential linearity error	DLE			-1.0	—	+1.0	LSB

Nonlinearity error: Deviation (error) in input/output curves with respect to an ideal straight line connecting output voltage at "06" and output voltage at "FF"

Differential linearity error: Deviation (error) in amplification with respect to theoretical increase in amplification per 1-bit increase in digital value.

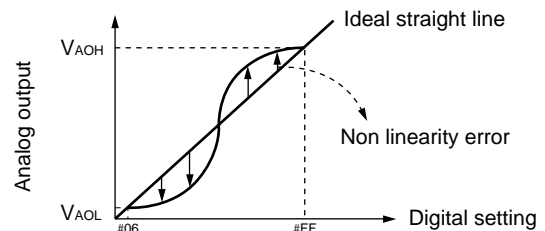

Note: The value of V_{AOH} and V_{DD} , and the value of V_{AOL} and GND are not necessarily equivalent.

(3) Operational Amplifier/Analog output section

($V_{DD} = V_{CC} = 5.0\text{ V}$, $T_a = -20^\circ\text{C}$ to $+85^\circ\text{C}$)

Parameter	Symbol	Pin name	Conditions	Value			Unit
				Min.	Typ.	Max.	
Power supply voltage	V_{CC}	V_{CC}	—	4.5	5.0	5.5	V
Power supply current	I_{CC}		#80 setting (Unloaded)	—	1.0	3.7	mA
Input leak current	I_{ILK2}	D ₄ to D ₁₁	$V_{in} = 0$ to V_{CC}	-10	—	+10	μA
“H” level digital input voltage	V_{IH2}		—	$0.5 \times V_{CC}$	—	—	V
“L” level digital input voltage	V_{IL2}		—	—	—	$0.2 \times V_{CC}$	V
“H” level digital output voltage	V_{OH2}		$I_{OH} = -0.4\text{ mA}$	$V_{CC} - 0.4$	—	—	V
“L” level digital output voltage	V_{OL2}		$I_{OL} = 2.5\text{ mA}$	—	—	0.4	V
Analog output minimum voltage 1	V_{AOL1}		AO ₁ to AO ₁₂	$I_{AL} = 0\text{ A}$ #00 setting	GND	—	0.1
Analog output minimum voltage 2	V_{AOL2}	$I_{AL} = 0.5\text{ mA}$ #00 setting		-0.2	GND	0.2	V
Analog output minimum voltage 3	V_{AOL3}	$I_{AH} = 0.5\text{ mA}$ #00 setting		GND	—	0.2	V
Analog output minimum voltage 4	V_{AOL4}	$I_{AL} = 1.0\text{ mA}$ #00 setting		-0.3	GND	0.3	V
Analog output minimum voltage 5	V_{AOL5}	$I_{AH} = 1.0\text{ mA}$ #00 setting		GND	—	0.3	V
Analog output maximum voltage 1	V_{AOH1}	AO ₁ to AO ₁₂	$I_{AL} = 0\text{ A}$ #FF setting	$V_{CC} - 0.1$	—	V_{CC}	V
Analog output maximum voltage 2	V_{AOH2}		$I_{AL} = 0.5\text{ mA}$ #FF setting	$V_{CC} - 0.2$	—	V_{CC}	V
Analog output maximum voltage 3	V_{AOH3}		$I_{AH} = 0.5\text{ mA}$ #FF setting	$V_{CC} - 0.2$	V_{CC}	$V_{CC} + 0.2$	V
Analog output maximum voltage 4	V_{AOH4}		$I_{AL} = 1.0\text{ mA}$ #FF setting	$V_{CC} - 0.3$	—	V_{CC}	V
Analog output maximum voltage 5	V_{AOH5}		$I_{AH} = 1.0\text{ mA}$ #FF setting	$V_{CC} - 0.3$	V_{CC}	$V_{CC} + 0.3$	V

Note: I_{AH} : Analog output sink current I_{AL} : Analog output source current

MB88146A

2. AC Characteristics

- For operation at $V_{CCD} = 5.0\text{ V}$

($V_{DD} = V_{CCA} = 5.0\text{ V}$, $T_a = -20^\circ\text{C}$ to $+85^\circ\text{C}$)

Parameter	Symbol	Conditions	Value			Unit
			Min.	Typ.	Max.	
Clock "L" level pulse width	t_{CKL}	—	200	—	—	ns
Clock "H" level pulse width	t_{CKH}	—	200	—	—	ns
Clock rise time	t_{Cr}	—	—	—	200	ns
Clock fall time	t_{Cf}	—	—	—	200	ns
Serial input setup time	t_{SSU}	—	30	—	—	ns
Serial input hold time	t_{SHD}	—	60	—	—	ns
Serial output delay time	t_{SOD}	See "Load condition 1"	0	80	170	ns
\overline{CS} input setup time	t_{CSU}	—	100	—	—	ns
\overline{CS} hold time	t_{CCH}	—	200	—	—	ns
\overline{CS} "H" level hold time	t_{CSH}	—	100	—	—	ns
Data output enable time	t_{SO}	—	—	—	200	ns
Data output float time	t_{SOZ}	—	—	—	200	ns
Parallel input setup time	t_{PSU}	—	30	—	—	ns
Parallel input hold time	t_{PHD}	—	60	—	—	ns
Parallel output delay time	t_{POD}	See "Load condition 1"	—	100	170	ns
Analog output delay time	t_{AOD}	See "Load condition 2"	—	30	100	μs
Power supply rise time	t_R	—	—	—	50	ms
Power-on reset non-startup power supply variation	ΔV_R	—	-10	—	10	$\text{V}/\mu\text{s}$

- For operation at $V_{CCD} = 3.0\text{ V}$ *1

($V_{CCD} = 3.0\text{ V}$, $T_a = -20^\circ\text{C}$ to $+85^\circ\text{C}$)

Parameter	Symbol	Conditions	Value			Unit
			Min.	Typ.	Max.	
Serial output delay time	t_{SOD}	See "Load condition 1"*2	0	120	300	ns
Parallel output delay time	t_{POD}	See "Load condition 2"*3	—	120	300	ns

*1: Items not listed are identical to characteristics for $V_{CCD} = 5.0\text{ V}$.

*2: Cascade connection enabled at 1.5 MHz.

*3: Applied to D0 to D3 operating at V_{CCD} .

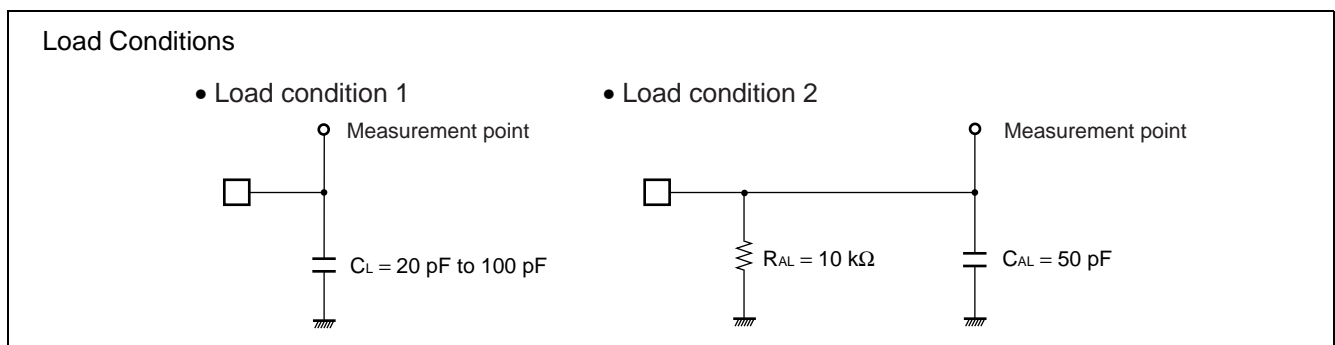

• Input/Output Timing (\overline{CS} method)

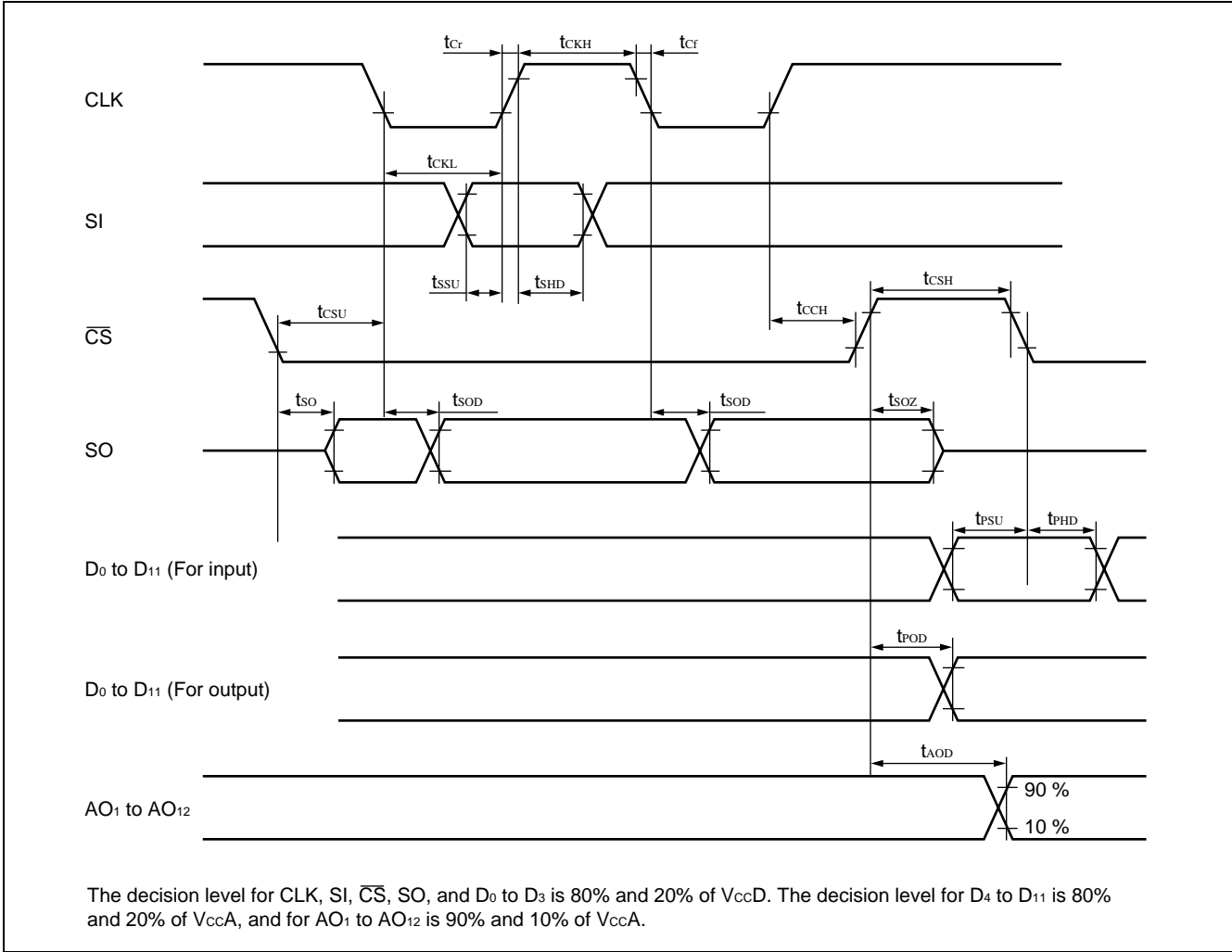

• Power Supply Timing

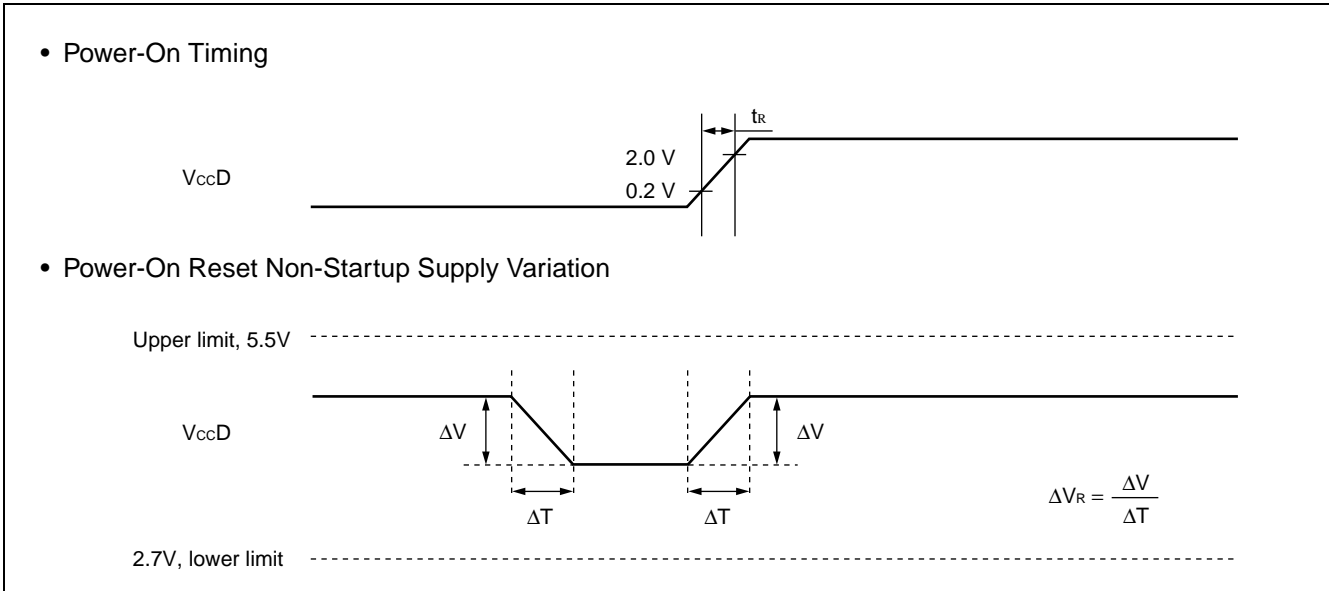

MB88146A

3. Analog Output Noise Characteristic

($V_{DD} = V_{CCD} = V_{CCA} = 5.0\text{ V}$, $T_a = +25^\circ\text{C}$)

Parameter	Symbol	Conditions	Measurement condition	Value			Unit
				Min.	Typ.	Max.	
Digital supply noise reduction ratio	P_{SRD}	$f_{NOISE} = 1\text{ kHz}$	1	—	—	20	dB
Analog supply noise reduction ratio	P_{SRA}	$f_{NOISE} = 1\text{ kHz}$	1	—	—	20	dB
D/A supply noise reduction ratio	P_{SRDA}	$f_{NOISE} = 1\text{ kHz}$	1	—	—	0	dB
Operating noise	V_{N1}	<ul style="list-style-type: none"> • During serial transfer • During analog operation • During Hi-Z commands. See "Operating Noise V_{N1} ."	2	-30	—	30	mV
I/O expander operating noise 1	V_{N2}	<ul style="list-style-type: none"> • Serial → parallel conversion See "I/O Expander Operating Noise 1 V_{N2} ." During digital-only pin operation <ul style="list-style-type: none"> • During parallel → serial conversion • ESR setting During digital input/digital output switching	2	-30	—	30	mV
I/O expander operating noise 2	V_{N3}	<ul style="list-style-type: none"> • During serial → parallel conversion See "I/O Expander Operating Noise 2 V_{N3} ." During digital/analog capable pin operation <ul style="list-style-type: none"> • ESR setting During digital output/digital output switching	2	-0.1	—	0.1	V

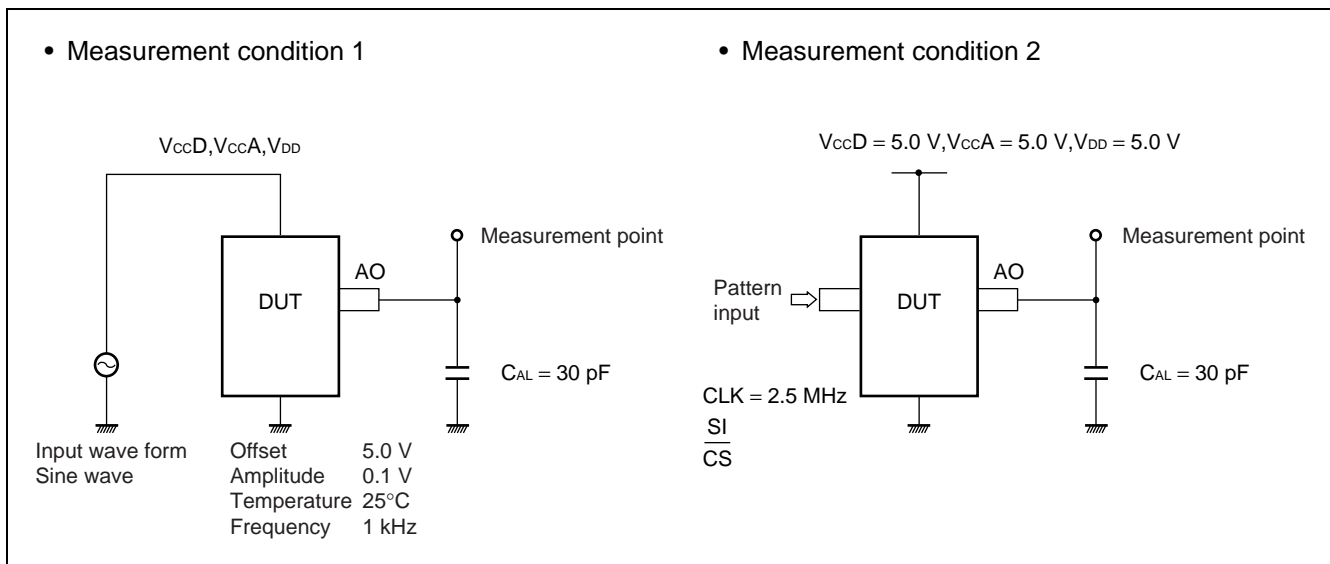

- Analog Output Noise Description

- Output Noise V_{N1}

Noise to analog output during serial data transfer, analog operation, Hi-Z commands.

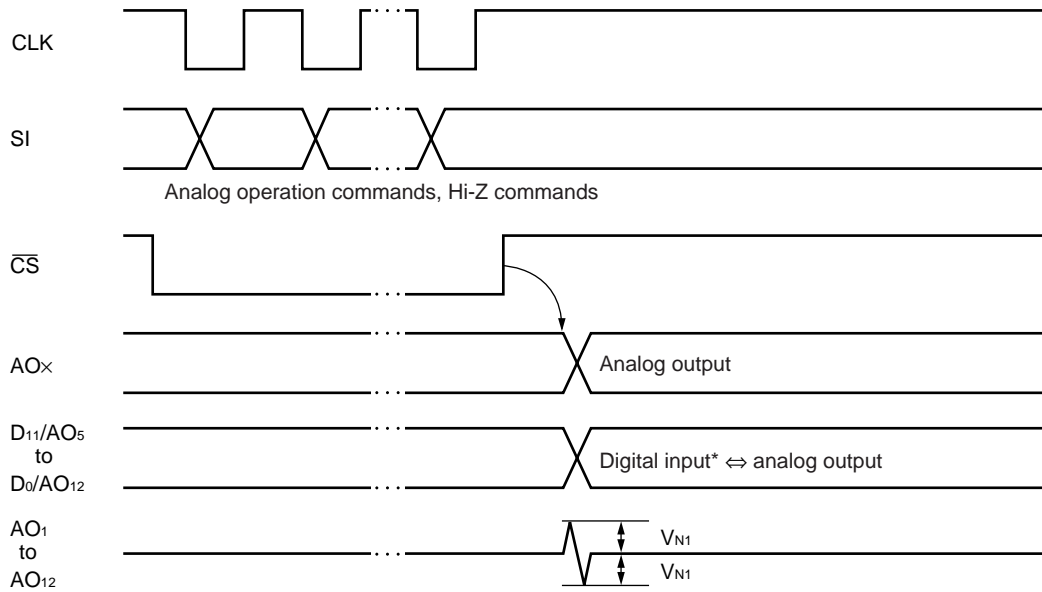

* Hi-Z state = digital input state.

- I/O Expander Operation Noise 1 V_{N2}

Noise to analog output during parallel → serial conversion commands, serial → parallel conversion command for digital-only pins, or ESR setting commands for switching between digital input and digital output.

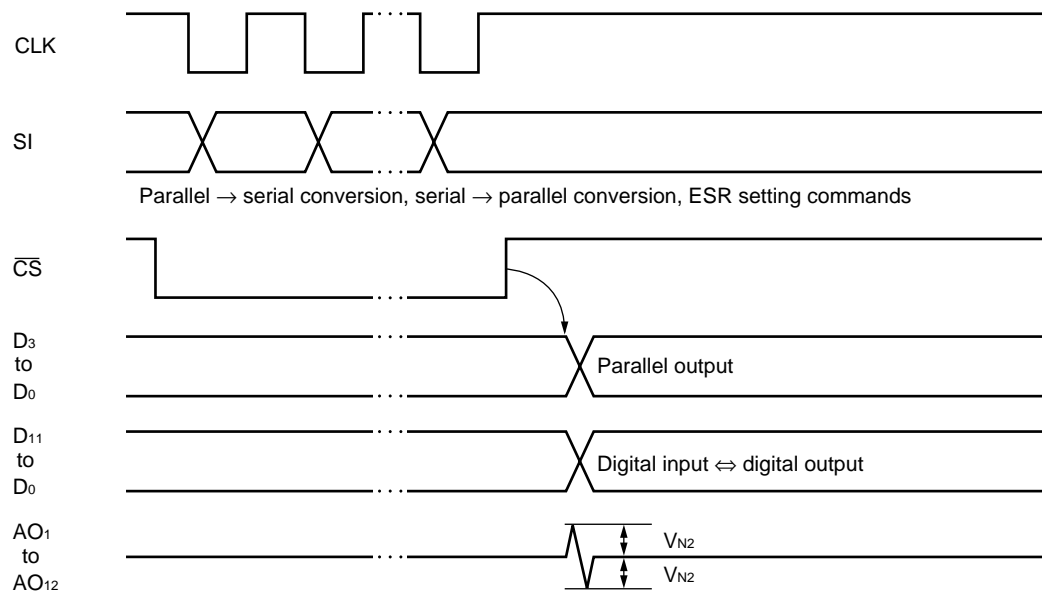

(Continued)

MB88146A

(Continued)

- I/O Expander Operation Noise $2 V_{N3}$

Noise to analog output during serial → parallel switching commands for digital-only pins, or ESR setting commands for switching between digital output and analog output.

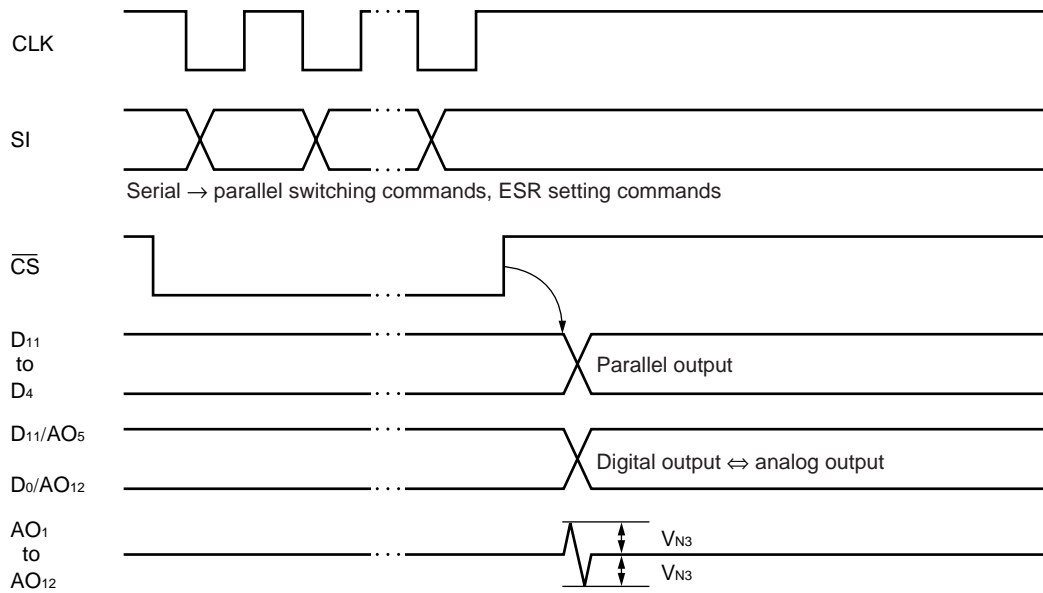

■ DATA INPUT/OUTPUT TIMING

MB88146A Data Input/Output Timing (Serial Bus Format)

- D/A converter operation, and I/O expander (serial → parallel conversion) operation, and ESR writing operation.

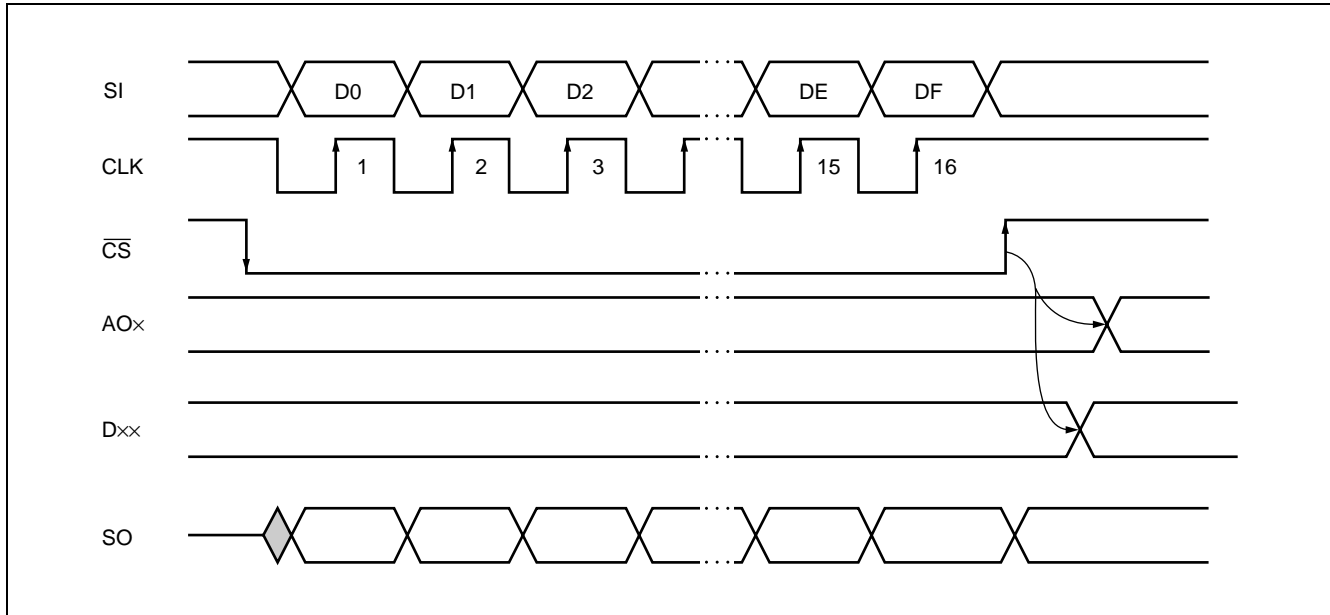

Data input is enabled at the falling edge of the \overline{CS} signal. 16-bit data is input, and the shift register command is executed at the rising edge of \overline{CS} .

In D/A converter operation, the analog output selected at the rising edge of \overline{CS} is the conversion result. In serial → parallel conversion, the digital output selected at the rising edge of \overline{CS} is the conversion result. In ESR write operation, ESR data is set and pin status determined at the rising edge of \overline{CS} .

- I/O expander (parallel → serial conversion) operation

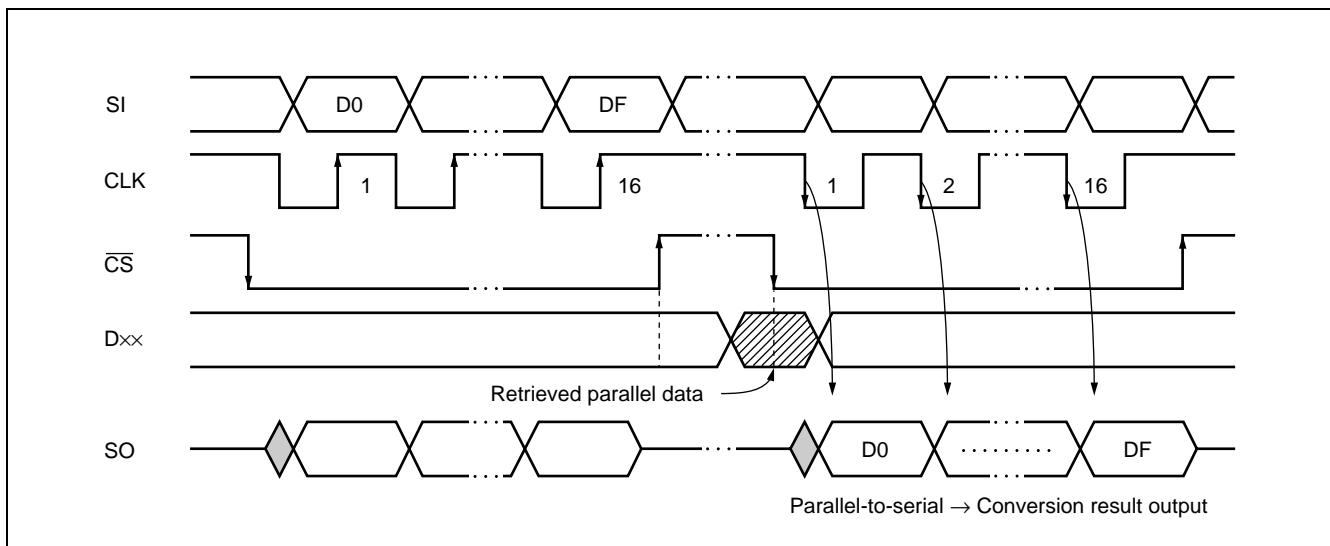

Data input is enabled at the falling edge of the \overline{CS} signal. 16-bit data (parallel → serial conversion commands) is input and commands accepted at the rising edge of \overline{CS} . At the falling edge of \overline{CS} , data from the parallel input is loaded into bits D4 to DF of the shift register, and output from the SO pin timed to the falling edge of the CLK signal.

MB88146A

■ USAGE PRECAUTIONS

1. Preventing Latch-Up

A condition known as “latch-up” may occur when the input or output pins of a CMOS IC device are exposed to voltages higher than V_{CCD} or V_{CCA} or lower than GND voltage, or when voltages are applied to the device in excess of rated values for V_{CCD} , V_{CCA} , or V_{DD} to GND voltages. Latchup produces a rapid increase in power supply current, and may result in thermal destruction of elements. Users should take sufficient precautions to ensure that absolute maximum ratings are not exceeded at any time during use.

2. Power Supply Pins

The power supply should be connected to the V_{CCD} , V_{CCA} , V_{DD} , and GND terminals of the MB88146A with as low an impedance as possible.

In addition, it is recommended that ceramic capacitors or approximately 0.1 μF be connected as bypass capacitors between the V_{CCD} , V_{CCA} , and V_{DD} terminals and the GND terminals.

■ ORDERING INFORMATION

Part number	Package	Remarks
MB88146AP	24-pin Plastic DIP (DIP-24P-M02)	
MB88146APFV	24-pin Plastic SSOP (FPT-24P-M03)	

PACKAGE DIMENSIONS

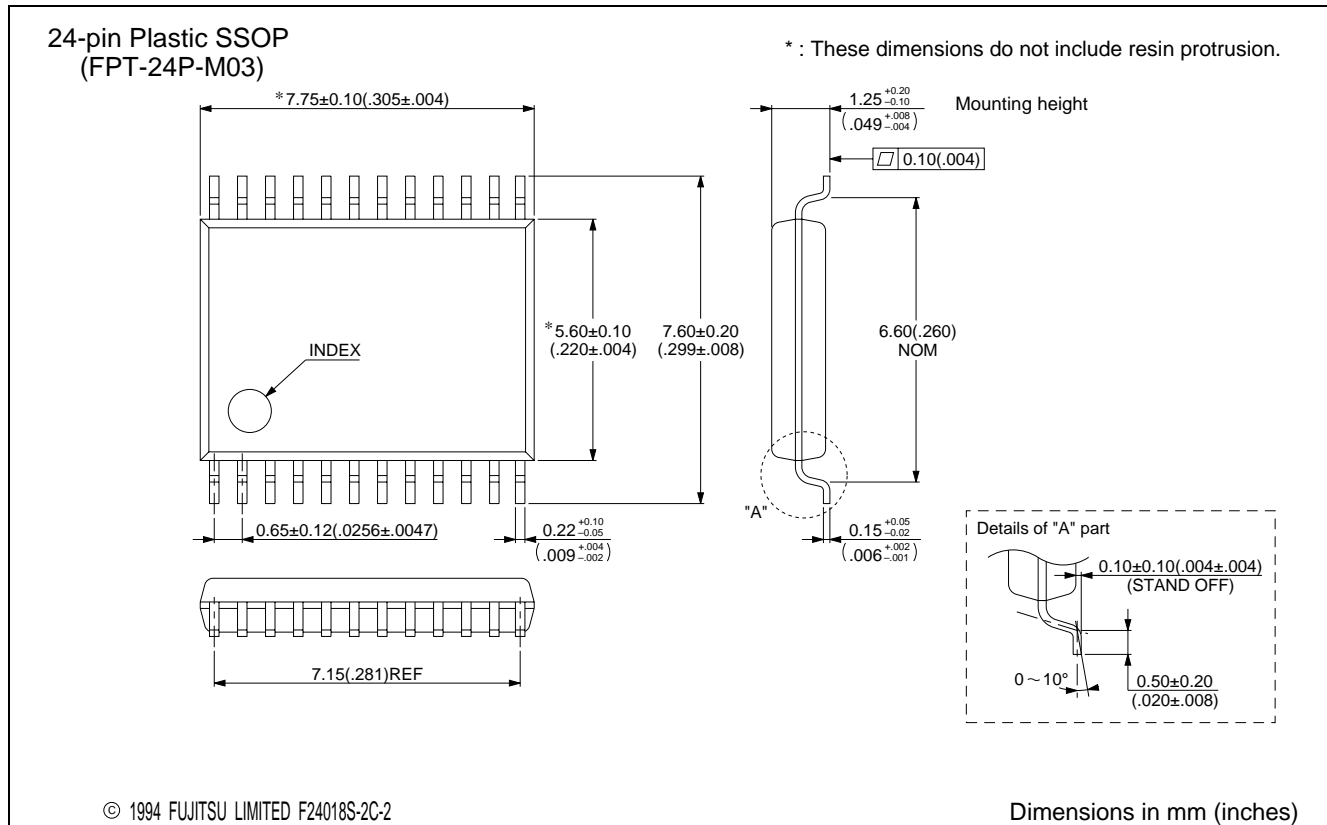
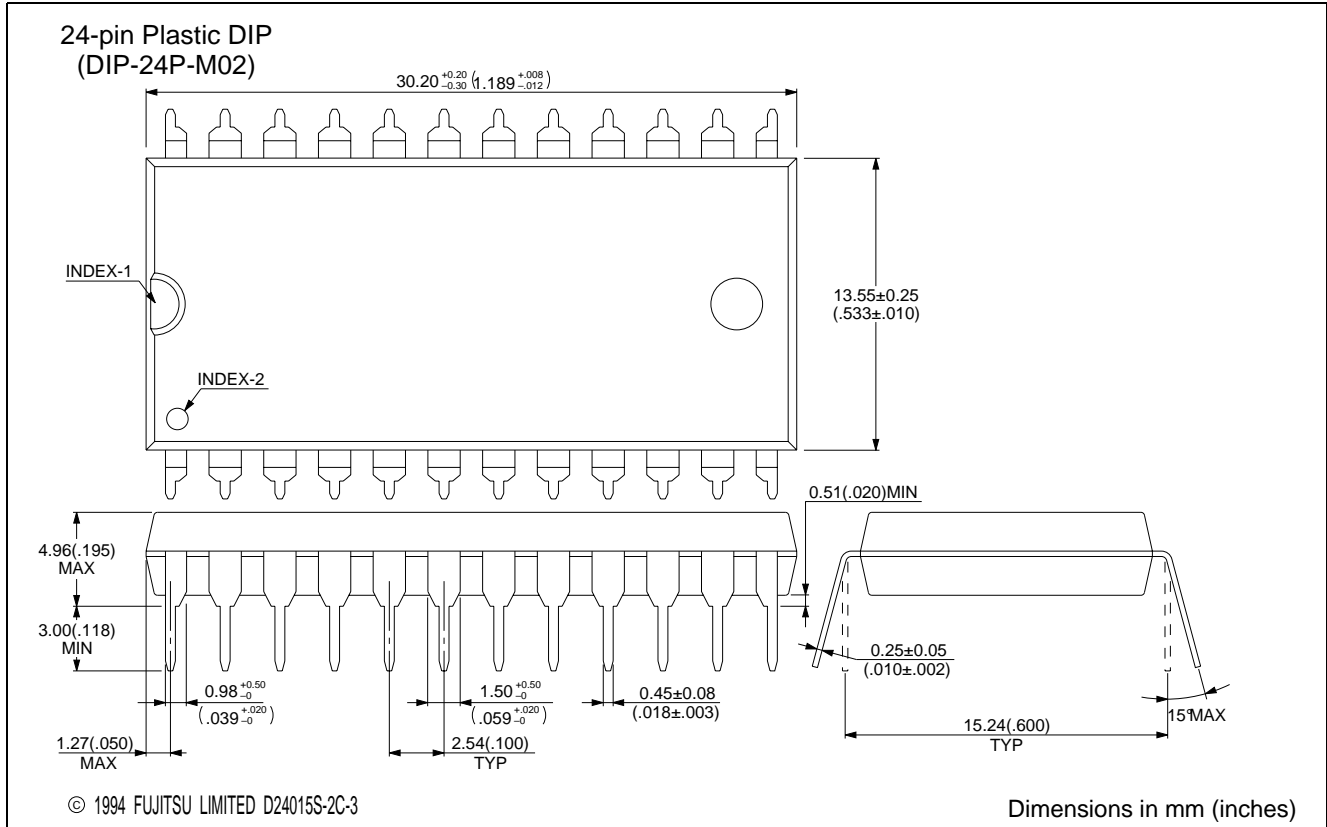

FUJITSU MICROELECTRONICS LIMITED

Shinjuku Dai-Ichi Seimei Bldg. 7-1, Nishishinjuku 2-chome, Shinjuku-ku,
Tokyo 163-0722, Japan Tel: +81-3-5322-3347 Fax: +81-3-5322-3387
<http://jp.fujitsu.com/fml/en/>

For further information please contact:

North and South America

FUJITSU MICROELECTRONICS AMERICA, INC.
1250 E. Arques Avenue, M/S 333
Sunnyvale, CA 94085-5401, U.S.A.
Tel: +1-408-737-5600 Fax: +1-408-737-5999
<http://www.fma.fujitsu.com/>

Europe

FUJITSU MICROELECTRONICS EUROPE GmbH
Pittlerstrasse 47, 63225 Langen,
Germany
Tel: +49-6103-690-0 Fax: +49-6103-690-122
<http://emea.fujitsu.com/microelectronics/>

Korea

FUJITSU MICROELECTRONICS KOREA LTD.
206 KOSMO TOWER, 1002 Daechi-Dong,
Kangnam-Gu, Seoul 135-280
Korea
Tel: +82-2-3484-7100 Fax: +82-2-3484-7111
<http://www.fmk.fujitsu.com/>

Asia Pacific

FUJITSU MICROELECTRONICS ASIA PTE LTD.
151 Lorong Chuan, #05-08 New Tech Park,
Singapore 556741
Tel: +65-6281-0770 Fax: +65-6281-0220
<http://www.fujitsu.com/sg/services/micro/semiconductor/>

FUJITSU MICROELECTRONICS SHANGHAI CO., LTD.
Rm.3102, Bund Center, No.222 Yan An Road(E),
Shanghai 200002, China
Tel: +86-21-6335-1560 Fax: +86-21-6335-1605
<http://cn.fujitsu.com/fmc/>

FUJITSU MICROELECTRONICS PACIFIC ASIA LTD.
10/F., World Commerce Centre, 11 Canton Road
Tsimshatsui, Kowloon
Hong Kong
Tel: +852-2377-0226 Fax: +852-2376-3269
<http://cn.fujitsu.com/fmc/tw>

All Rights Reserved.

The contents of this document are subject to change without notice.

Customers are advised to consult with sales representatives before ordering.

The information, such as descriptions of function and application circuit examples, in this document are presented solely for the purpose of reference to show examples of operations and uses of FUJITSU MICROELECTRONICS device; FUJITSU MICROELECTRONICS does not warrant proper operation of the device with respect to use based on such information. When you develop equipment incorporating the device based on such information, you must assume any responsibility arising out of such use of the information.

FUJITSU MICROELECTRONICS assumes no liability for any damages whatsoever arising out of the use of the information.

Any information in this document, including descriptions of function and schematic diagrams, shall not be construed as license of the use or exercise of any intellectual property right, such as patent right or copyright, or any other right of FUJITSU MICROELECTRONICS or any third party or does FUJITSU MICROELECTRONICS warrant non-infringement of any third-party's intellectual property right or other right by using such information. FUJITSU MICROELECTRONICS assumes no liability for any infringement of the intellectual property rights or other rights of third parties which would result from the use of information contained herein.

The products described in this document are designed, developed and manufactured as contemplated for general use, including without limitation, ordinary industrial use, general office use, personal use, and household use, but are not designed, developed and manufactured as contemplated (1) for use accompanying fatal risks or dangers that, unless extremely high safety is secured, could have a serious effect to the public, and could lead directly to death, personal injury, severe physical damage or other loss (i.e., nuclear reaction control in nuclear facility, aircraft flight control, air traffic control, mass transport control, medical life support system, missile launch control in weapon system), or (2) for use requiring extremely high reliability (i.e., submersible repeater and artificial satellite).

Please note that FUJITSU MICROELECTRONICS will not be liable against you and/or any third party for any claims or damages arising in connection with above-mentioned uses of the products.

Any semiconductor devices have an inherent chance of failure. You must protect against injury, damage or loss from such failures by incorporating safety design measures into your facility and equipment such as redundancy, fire protection, and prevention of over-current levels and other abnormal operating conditions.

Exportation/release of any products described in this document may require necessary procedures in accordance with the regulations of the Foreign Exchange and Foreign Trade Control Law of Japan and/or US export control laws.

The company names and brand names herein are the trademarks or registered trademarks of their respective owners.