

Linear IC Converter

CMOS

D/A Converter for Digital Tuning (Compatible with I²C Bus)

MB88141A

■ DESCRIPTION

The FUJITSU MICROELECTRONICS MB88141A is an 8-bit D/A converter with 12 built-in channels.

The 12 analog output channels have built-in OP Amps, providing large current drive capability.

Data input is compatible with I²C specifications, and is controlled by two control lines.

The built-in I/O expander function allows the MB88141A to be controlled by devices incompatible with I²C bus specifications (provides conversion between I²C serial and 8- or 4-bit parallel I/O).

The MB88141A is ideal for replacing electronic knob or pre-set variable resistance tuning devices.

■ FEATURES

- Ultra-low power consumption (0.9 mW/channel Typ.)
- Ultra-compact package
- Built-in 12-channel R-2R type 8-bit D/A converter
- Built-in analog output amplifier (maximum sink current 1.0 mA, maximum source current 1.0 mA)
- Analog output range 0 V to V_{CC}

(Continued)

■ PACKAGES

24-pin plastic DIP

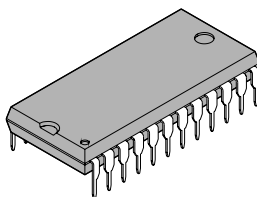

(DIP-24P-M02)

24-pin plastic SOP

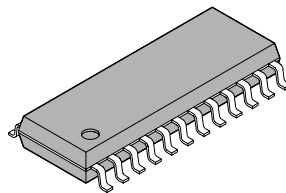

(FPT-24P-M01)

24-pin plastic SSOP

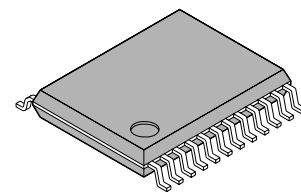

(FPT-24P-M03)

“Purchase of Fujitsu Microelectronics I²C components conveys a license under the Philips I²C Patent Rights to use these components in an I²C system, provided that the system conforms to the I²C Standard Specification as defined by Philips.”

MB88141A

(Continued)

- 5 V single power supply
- Power supply/GND for MCU interface and OP Amp is separate from power supply/GND for D/A converter
- Power supply for D/A converter is divided into two systems for V_{DD1}/V_{SS1} (AO1 to AO4) and V_{DD2}/V_{SS2} (AO5 to AO12) , allowing separate level settings for each system
- Compatible with serial data input, I²C specifications
- Built-in I/O expander function (converts between I²C serial and 8-or 4-bit parallel)
- CMOS process
- Packages : DIP 24-pin, SOP 24-pin, SSOP 24-pin

■ PIN ASSIGNMENT

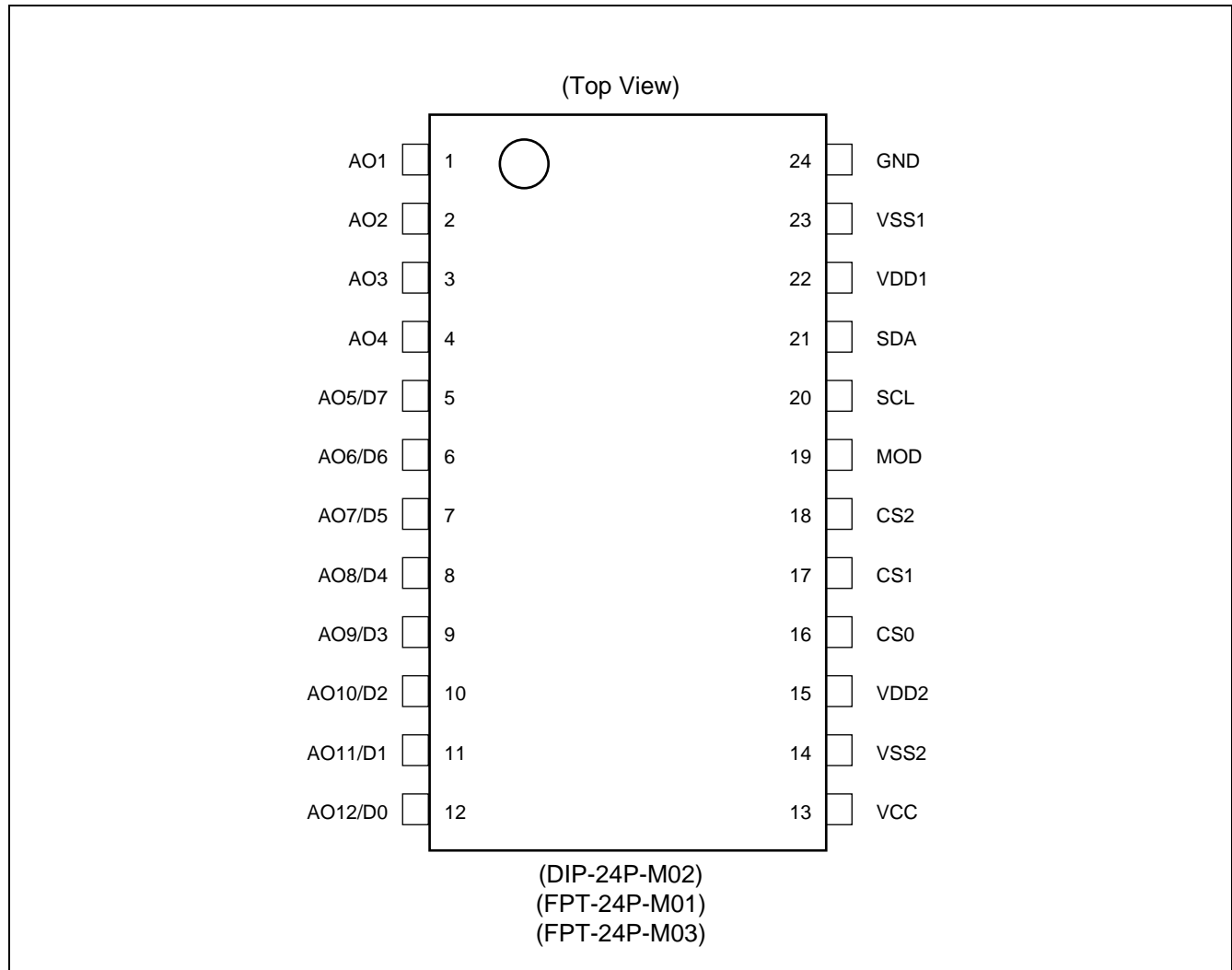

MB88141A

■ PIN DESCRIPTION

Pin no.	Symbol	Circuit Type	I/O	Description
21	SDA	C	I/O	I ² C bus data input/output pin (hysteresis input). Outputs the acknowledge signal.
20	SCL	B	I	I ² C bus shift clock input pin (hysteresis input) .
19	MOD	A	I	D/A converter and I/O expander mode switching pin. *1, *2 Input "L" to operate as a D/A converter, "H" to operate as I/O expander and D/A converter.
16 17 18	CS0 CS1 CS2	A	I	These pins set the lower 3 bits of the slave address. *1 This allows up to eight MB88141A chips to be used on the same bus line.
1 2 3 4	AO1 AO2 AO3 AO4	D	O	8-bit D/A outputs with OP Amp. *2
5 6 7 8 9 10 11 12	AO5/D7 AO6/D6 AO7/D5 AO8/D4 AO9/D3 AO10/D2 AO11/D1 AO12/D0	E	I/O	8-bit D/A outputs with OP Amp. *2 In I/O expander operation, these pins function as parallel data input/output pins.
13	VCC	Power supply	—	Power supply pin for digital circuits and OP Amp.
24	GND	GND	—	GND pin for digital circuits and OP Amp.
22	VDD1	Power supply	—	Reference power supply pin for D/A converter (H) . AO1 to AO4.
23	VSS1	Power supply	—	Reference power supply pin for D/A converter (L) . AO1 to AO4.
15	VDD2	Power supply	—	Reference power supply pin for D/A converter (H) . AO5 to AO12.
14	VSS2	Power supply	—	Reference power supply pin for D/A converter (L) . AO5 to AO12.

*1: The MOD and CS0-CS2 pins should be used with fixed level input.

*2: When using the I/O expander function together with the D/A converter function, take care that D/A converter output precision is within a range that will not affect overall system operation.

■ BLOCK DIAGRAM

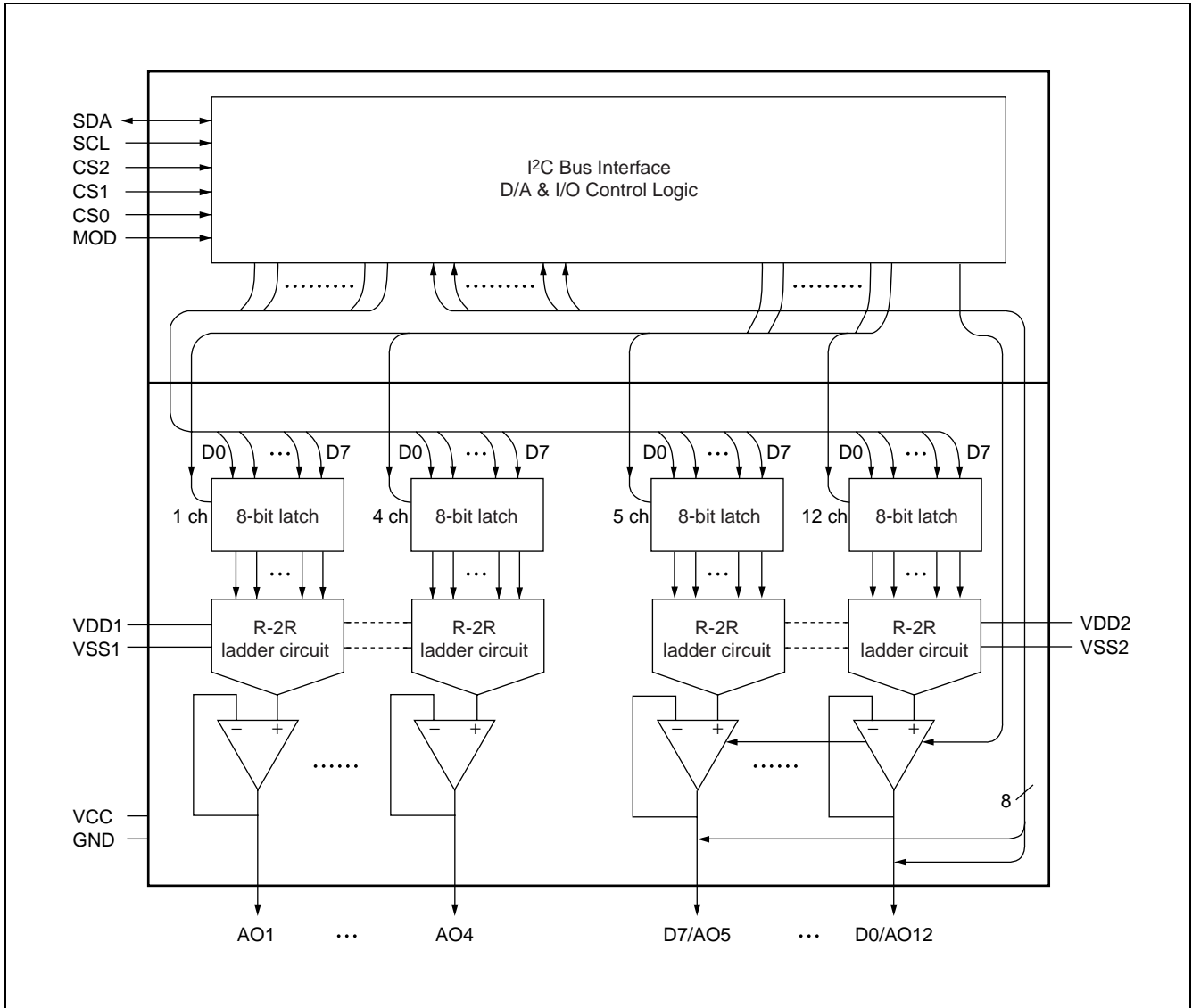

■ I/O CIRCUIT TYPE

Type	Circuit	Remarks
A		Input dedicated pin
B		Input dedicated pin <ul style="list-style-type: none"> • I²C bus pin • Hysteresis input
C		Input/output pin <ul style="list-style-type: none"> • I²C bus pin • Hysteresis input • N-ch open drain output
D		Analog output pin

(Continued)

(Continued)

Type	Circuit	Remarks
E		Analog/digital input/output pin

Note : Circuit types B and C are I²C bus pins. Caution should be taken in using these pins because when the VCC power is off current from the I²C bus line power supply VCCS can enter the VCC side of the device power supply.

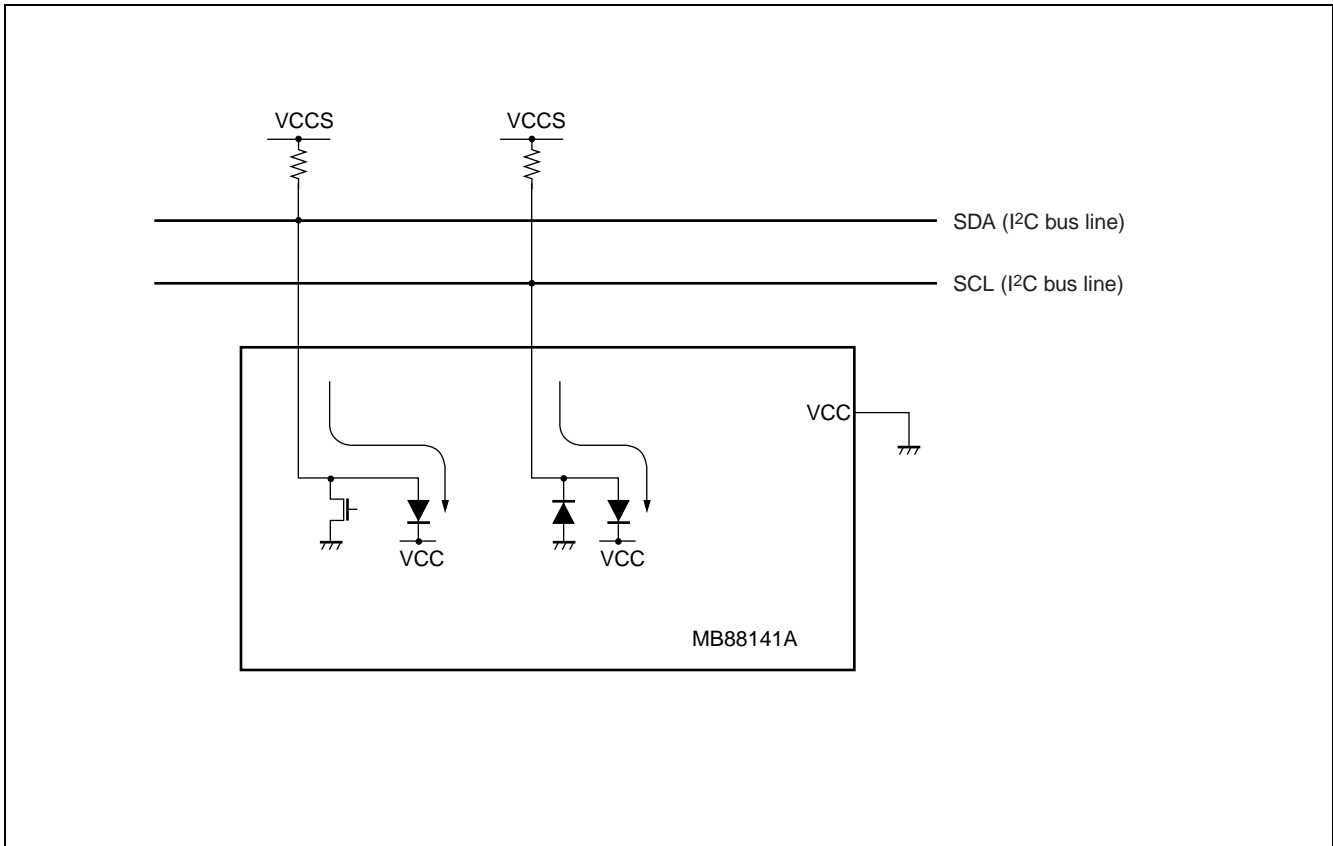

MB88141A

■ DATA CONFIGURATION

The MB88141A has the following data configuration the two operating modes (D/A converter (12-channel) and I/O expander plus D/A converter), selected by the MOD pin.

1. For D/A Converter (12-channel) Operation (MOD = "L")

(1) I²C Bus Format

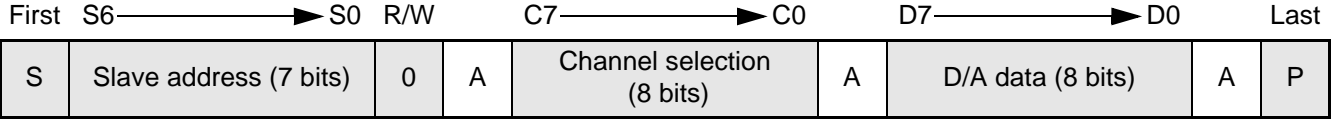

: Sent from master device : Sent from MB88141A (slave device)

S : "Start" condition

P : "Stop" condition

A : "Acknowledge" output

(2) Slave Address Comparison (7 bits)

Slave address input (7 bits)						
S6	S5	S4	S3	S2	S1	S0
1	0	0	1	0	0	0
1	0	0	1	0	0	1
1	0	0	1	0	1	0
1	0	0	1	0	1	1
1	0	0	1	1	0	0
1	0	0	1	1	0	1
1	0	0	1	1	1	0
1	0	0	1	1	1	1

=
=
=
=
=
=
=
=
=

Internally fixed				Externally set		
CS6	CS5	CS4	CS3	CS2	CS1	CS0
1	0	0	1	0	0	0
1	0	0	1	0	0	1
1	0	0	1	0	1	0
1	0	0	1	0	1	1
1	0	0	1	1	0	0
1	0	0	1	1	0	1
1	0	0	1	1	1	0
1	0	0	1	1	1	1

Address comparison: Operates only for devices whose own slave address (internally fixed CS6 to CS3 and externally set CS2 to CS0) matches the slave address input value.

(3) R/W Selection (1 bit)

Fixed at "0" (the D/A converter performs write operations only) .

(4) Channel Selection (8 bits)

C7	C6	C5	C4	C3	C2	C1	C0	Channel select
×	×	×	×	0	0	0	0	All channels selected *1
×	×	×	×	0	0	0	1	AO1 selected
∟	∟	∟	∟	∟	∟	∟	∟	∟
×	×	×	×	1	1	0	0	AO12 selected
×	×	×	×	1	1	0	1	Don't Care
×	×	×	×	1	1	1	0	Don't Care
×	×	×	×	1	1	1	1	All channels selected *2

× : Don't Care

*1: The 1 byte of data following the channel selection is set on all channels (all channels set to same data value) .

S	Slave address (7 bits)	0	A	X X X X 0 0 0 0	A	D/A data (8 bits)	A	P
---	------------------------	---	---	-----------------	---	-------------------	---	---

*2: The 12 bytes of data following the channel selection are set on all channels (all channels set to separate data values) .

S	Slave address	0	A	X X X X 1 1 1 1	A	AO1 data	A	...	AO12 data	A	P
---	---------------	---	---	-----------------	---	----------	---	-----	-----------	---	---

: Sent from master device : Sent from MB88141A (slave device)

S : "Start" condition

P : "Stop" condition

A : "Acknowledge" output

Note: Setting will repeat, continuing in order from ch1, until the start and stop conditions are acknowledged.

(5) D/A Data (8 bits)

D7	D6	D5	D4	D3	D2	D1	D0	D/A output
0	0	0	0	0	0	0	0	$\equiv V_{SS}$
0	0	0	0	0	0	0	1	$\equiv (V_{REF} / 256) \times 1 + V_{SS}$
0	0	0	0	0	0	1	0	$\equiv (V_{REF} / 256) \times 2 + V_{SS}$
∟	∟	∟	∟	∟	∟	∟	∟	∟
1	1	1	1	1	1	1	0	$\equiv (V_{REF} / 256) \times 254 + V_{SS}$
1	1	1	1	1	1	1	1	$\equiv (V_{REF} / 256) \times 255 + V_{SS}$

Note: $V_{REF} = V_{DD} - V_{SS}$

MB88141A

2. For D/A Converter + I/O Expander Operation (MOD = "H")

(1) I²C Bus Format

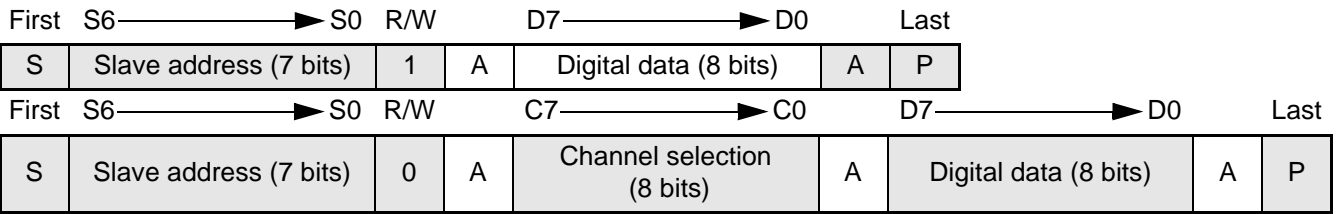

: Sent from master device : Sent from MB88141A (slave device)

S : "Start" condition

P : "Stop" condition

A : "Acknowledge" output

(2) Slave Address Comparison (7 bits)

Slave address comparison is the same as for D/A converter (12-channel) operation (see "1. (2) "Slave Address Comparison"), with the exception that the CS2 setting determines the number of D/A converter channels and the number of I/O expander bits.

CS2	D/A converter	I/O expander
0	4 channels (AO1 to AO4)	8 bits (D7 to D0)
1	8 channels (AO1 to AO8)	4 bits (D3 to D0)

When CS2 = "1" is selected, the upper 4 bits (D7 to D4) of write operations (I²C bus to parallel interface) are ignored, and the upper 4 bits of read operations (parallel interface to I²C bus) are output at "0" (low) .

(3) R/W Selection (1 bit)

R/W	I/O expander operation	D/A converter operation
0	I ² C bus input → parallel data output	I ² C bus input → analog output
1	Parallel data input → I ² C bus output	—

(4) Channel Selection (8 bits)

C7	C6	C5	C4	C3	C2	C1	C0	Channel select
×	×	×	×	0	0	0	0	I/O expander operation
×	×	×	×	0	0	0	1	AO1 selected
∟	∟	∟	∟	∟	∟	∟	∟	∟
×	×	×	×	0	1	0	0	AO4 selected
×	×	×	×	0	1	0	1	Don't care (AO5 selected)
∟	∟	∟	∟	∟	∟	∟	∟	∟
×	×	×	×	1	0	0	0	Don't care (AO8 selected)
×	×	×	×	1	0	0	1	Don't Care
∟	∟	∟	∟	∟	∟	∟	∟	∟
×	×	×	×	1	1	1	0	Don't Care
×	×	×	×	1	1	1	1	I/O expander continuous operation

(): When using D/A converter 8 channel, I/O expander 4 bit operation.

× : Don't Care

(5) D/A Data (8 bits)

Same as "1 (5) D/A Data (8 bits)".

(6) I/O Expander Continuous Operation

I²C bus input → parallel data output

S	Slave address	0	A	X X X X 1 1 1 1	A	Digital data	A	...	Digital data	A	P
---	---------------	---	---	-----------------	---	--------------	---	-----	--------------	---	---

Note: In continuous operation, operation continues until start and stop conditions are acknowledged.

Parallel data input → I²C bus output

S	Slave address	1	A	Digital data	A	Digital data	A	...	Digital data	A	P
---	---------------	---	---	--------------	---	--------------	---	-----	--------------	---	---

: Sent from master device : Sent from MB88141A (slave device)

S : "Start" condition

P : "Stop" condition

A : "Acknowledge" output

MB88141A

TIMING DIAGRAM (I²C BUS SPECIFICATIONS)

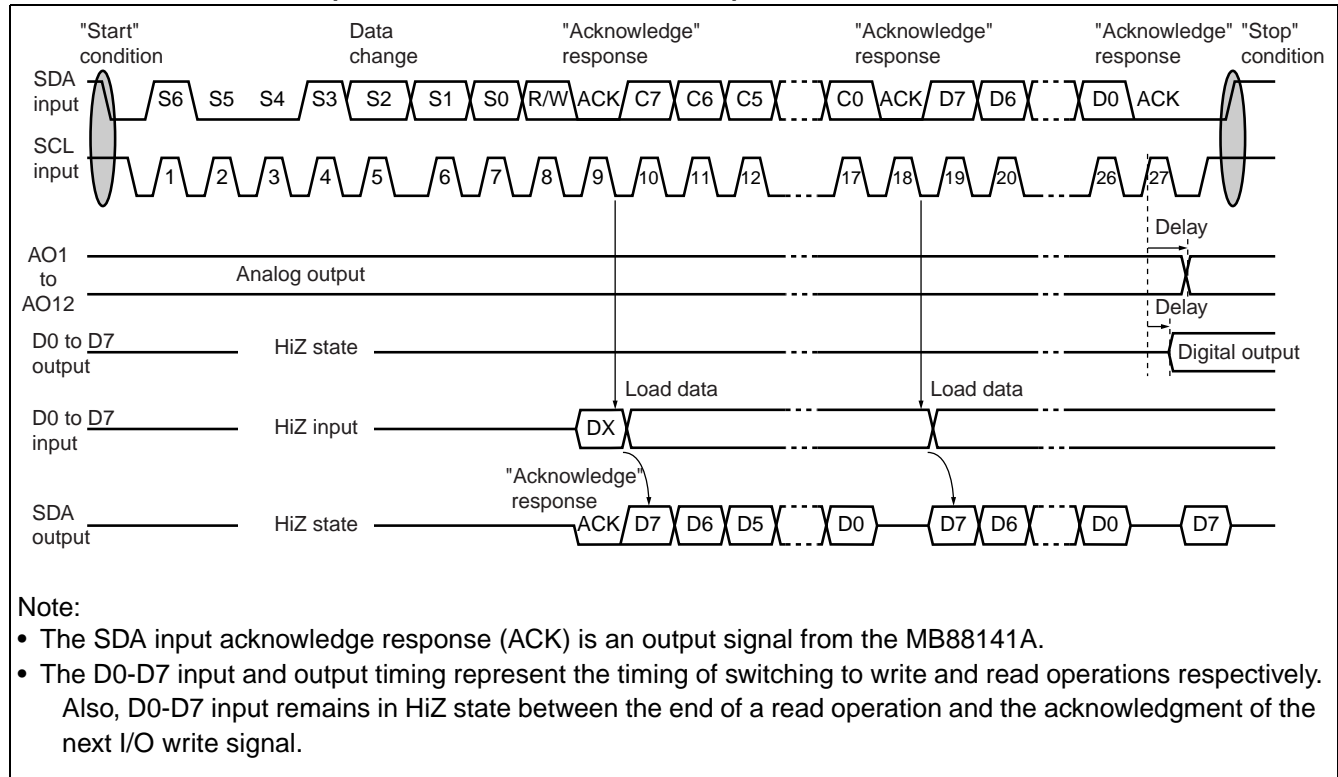

ANALOG OUTPUT VOLTAGE RANGE

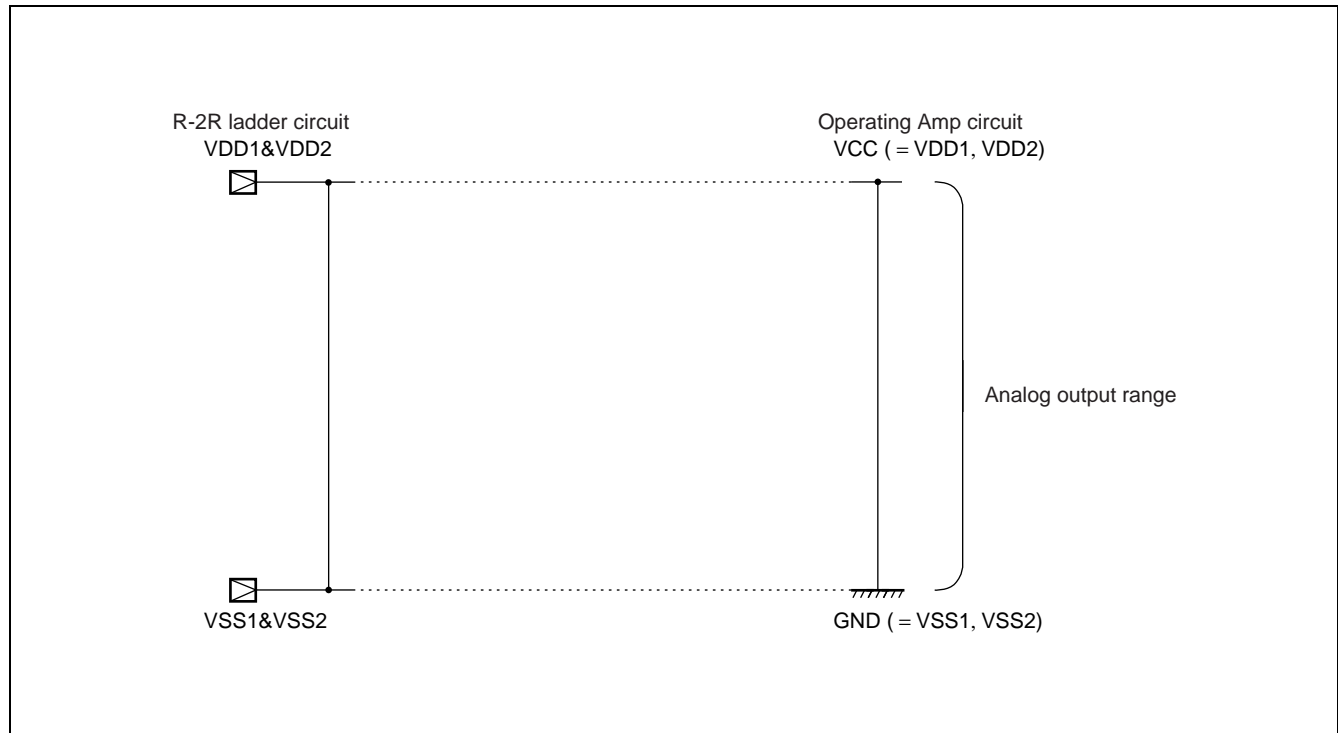

■ ABSOLUTE MAXIMUM RATINGS

Parameter	Symbol	Conditions	Rating		Unit
			Min.	Max.	
Supply voltage	V _{CC}	With reference to GND, at Ta = +25 °C	-0.3	+7.0 *	V
	V _{DD}		-0.3	+7.0 *	V
	V _{SS}		-0.3	+7.0 *	V
Input voltage	V _{IN}		-0.3	V _{CC} + 0.3	V
Output voltage	V _{OUT}		-0.3	V _{CC} + 0.3	V
Power consumption	P _D	—	—	250	mW
Operating temperature	Ta	—	-20	+85	°C
Storage temperature	Tstg	—	-55	+120	°C

*: V_{CC} ≥ V_{DD1} ≥ V_{SS1}, V_{CC} ≥ V_{DD2} ≥ V_{SS2}

WARNING: Semiconductor devices can be permanently damaged by application of stress (voltage, current, temperature, etc.) in excess of absolute maximum ratings. Do not exceed these ratings.

■ RECOMMENDED OPERATING CONDITIONS

Parameter	Symbol	Conditions	Value			Unit
			Min.	Typ.	Max.	
Supply voltage 1	V _{CC}	—	4.50	5.00	5.50	V
	GND	—	—	0	—	V
Supply voltage 2	V _{DD1}	V _{CC} ≥ V _{DD1} > V _{SS1}	2.00	—	V _{CC}	V
	V _{SS1}	V _{DD1} - V _{SS1} ≥ 2.0 V	0.00	—	3.50	V
Supply voltage 3	V _{DD2}	V _{CC} ≥ V _{DD2} > V _{SS2}	2.00	—	V _{CC}	V
	V _{SS2}	V _{DD2} - V _{SS2} ≥ 2.0 V	0.00	—	3.50	V
Analog output current	I _{AL}	Source current	0	—	1.00	mA
	I _{AH}	Sink current	0	—	1.00	mA
Oscillator limit output capacitance	C _{OL}	—	—	—	1.00	μF
Digital data setting range	—	—	#00	—	#FF	—
Operating temperature	Ta	—	-20	—	+85	°C

WARNING: The recommended operating conditions are required in order to ensure the normal operation of the semiconductor device. All of the device's electrical characteristics are warranted when the device is operated within these ranges.

Always use semiconductor devices within their recommended operating condition ranges. Operation outside these ranges may adversely affect reliability and could result in device failure.

No warranty is made with respect to uses, operating conditions, or combinations not represented on the data sheet. Users considering application outside the listed conditions are advised to contact their representatives beforehand.

MB88141A

■ ELECTRICAL CHARACTERISTICS

1. DC Characteristics

(1) Digital Circuits

(VCC = +5 V ± 10%, GND = 0 V, Ta = -20 °C to +85 °C)

Parameter	Symbol	Pin name	Conditions	Value			Unit
				Min.	Typ.	Max.	
Supply voltage	V _{CC}	VCC	—	4.50	5.00	5.50	V
Supply current	I _{CC}		SCL = 400 kHz, no load	—	1.00	3.70	mA
Input leak current	I _{ILK}	SDA, SCL CS0, CS1 CS2, MOD D0 to D7	V _{IN} = 0 to V _{CC}	-10	—	+10	μA
"L" level input voltage	V _{IL}		—	0	—	0.30 V _{CC}	V
"H" level input voltage	V _{IH}		—	0.70 V _{CC}	—	V _{CC}	V
Input hysteresis width	V _{HYS}	SDA, SCL	—	0.05 V _{CC}	—	—	V
"H" level output voltage	V _{OH}	D0 to D7	I _{OH} = -400 μA	V _{CC} - 0.4	—	—	V
"L" level output voltage	V _{OL1}		I _{OL} = 2.5 mA	—	—	0.40	
	V _{OL2}	SDA	I _{OL} = 3.0 mA	—	—	0.40	V
	V _{OL3}		I _{OL} = 6.0 mA	—	—	0.60	

(2) Analog Circuits 1

(VCC = +5 V ± 10%, GND = 0 V, Ta = -20 °C to +85 °C)

Parameter	Symbol	Pin name	Conditions	Value			Unit
				Min.	Typ.	Max.	
Current consumption	I _{DD}	VDD1, VDD2	No load I _{DD} = I _{DD1} + I _{DD2}	—	1.20	2.50	mA
Analog voltage	V _{DD}		VSS1, VSS2	V _{DD1} - V _{SS1} ≥ 2.0 V	2.0	—	V _{CC}
	V _{SS}	V _{DD2} - V _{SS2} ≥ 2.0 V		GND	—	3.5	
Resolution	Res	AO1 to AO12	No load V _{DD1} , V _{DD2} ≤ V _{CC} - 0.1 V V _{SS1} , V _{SS2} ≥ 0.1 V	—	8	—	bit
Monotonic increase	Rem			—	8	—	bit
Non-linearity error	LE			-1.5	—	+1.5	LSB
Differential linearity error	DLE			-1.0	—	+1.0	LSB

Non-linearity error :

Error in the input/output curve with respect to a straight line connecting output voltage at “00” and output voltage at “FF” levels.

Differential linearity error :

Deviation from ideal voltage with respect to a 1-bit increase in digital value.

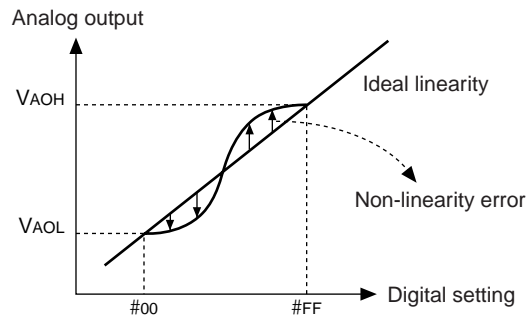

Note: V_{AOH} and V_{DD} , as well as V_{AOL} and V_{SS} are not necessarily the same values.

(3) Analog Circuits 2

($V_{CC} = V_{DD1} = V_{DD2} = +5\text{ V}$, $GND = V_{SS1} = V_{SS2} = 0\text{ V}$, $T_a = -20\text{ }^\circ\text{C}$ to $+85\text{ }^\circ\text{C}$)

Parameter	Symbol	Pin name	Conditions	Value			Unit	
				Min.	Typ.	Max.		
Output minimum voltage 1	V_{AOL1}	AO1 to AO12	$I_{AL} = 0\ \mu\text{A}$	Digital data "00"	V_{SS}	—	$V_{SS} + 0.1$	V
Output minimum voltage 2	V_{AOL2}		$I_{AL} = 500\ \mu\text{A}$		$V_{SS} - 0.2$	V_{SS}	$V_{SS} + 0.2$	V
Output minimum voltage 3	V_{AOL3}		$I_{AH} = 500\ \mu\text{A}$		V_{SS}	—	$V_{SS} + 0.2$	V
Output minimum voltage 4	V_{AOL4}		$I_{AL} = 1.0\ \text{mA}$		$V_{SS} - 0.3$	V_{SS}	$V_{SS} + 0.3$	V
Output minimum voltage 5	V_{AOL5}		$I_{AH} = 1.0\ \text{mA}$		V_{SS}	—	$V_{SS} + 0.3$	V
Output maximum voltage1	V_{AOH1}		$I_{AL} = 0\ \mu\text{A}$	Digital data "FF"	$V_{DD} - 0.1$	—	V_{DD}	V
Output maximum voltage2	V_{AOH2}		$I_{AL} = 500\ \mu\text{A}$		$V_{DD} - 0.2$	—	V_{DD}	V
Output maximum voltage3	V_{AOH3}		$I_{AH} = 500\ \mu\text{A}$		$V_{DD} - 0.2$	V_{DD}	$V_{DD} + 0.2$	V
Output maximum voltage4	V_{AOH4}		$I_{AL} = 1.0\ \text{mA}$		$V_{DD} - 0.3$	—	V_{DD}	V
Output maximum voltage5	V_{AOH5}		$I_{AH} = 1.0\ \text{mA}$		$V_{DD} - 0.3$	V_{DD}	$V_{DD} + 0.3$	V

MB88141A

2. AC Characteristics

Parameter	Symbol	Condition	Value				Unit	
			Standard mode		High-speed mode			
			Min.	Max.	Min.	Max.		
SCL clock frequency	f_{SCL}	—	0	100	0	400	kHz	
Bus free time between “stop” condition and “start” condition	t_{BUF}	—	4.7	—	1.3	—	μs	
Hold time (resend) “start” condition. The first clock pulse is generated after this interval.	$t_{HD ; STA}$	—	4.0	—	0.6	—		
SCL clock low hold time	t_{LOW}	—	4.7	—	1.3	—		
SCL clock high hold time	t_{HIGH}	—	4.0	—	0.6	—		
Resend “start” condition setup time	$t_{SU ; STA}$	—	4.7	—	0.6	—		
Data hold time	$t_{HD ; DAT}$	—	0	—	0	0.9		
Data setup time	$t_{SU ; DAT}$	—	250	—	100	—	ns	
SDA and SCL signal fall time	t_R	—	—	1000	$20 + 0.1 C_b$	300		
SDA and SCL signal rise time	t_F	—	—	300	$20 + 0.1 C_b$	300		
“Stop” condition setup time	$t_{SU ; STO}$	—	4.0	—	0.6	—	μs	
Pulse width of spike suppressed by input filter	t_{SP}	—	—	—	0	50	ns	
Output fall time when bus capacitance is between 10 pF and 400 pF	Sink current 3mA	t_{OF}	—	—	250	$20 + 0.1 C_b$		250
	Sink current 6mA		—	—	—	$20 + 0.1 C_b$		250
I ² C bus line capacitance load	C_b	—	—	400	—	400	pF	
D/A	Analog output settling time	$t_{DL ; AO}$	*1	—	100	—	100	μs
I/O expander	Digital output delay time	$t_{DL ; DO}$	*2	—	300	—	300	ns
	Input open time	$t_{DZ ; DI}$	*3	200	—	200	—	
	Digital input setup time	$t_{SU ; DI}$	—	250	—	100	—	
	Digital input hold time	$t_{HD ; DI}$	—	0.9	—	0.9	—	μs

*1: Load condition 1

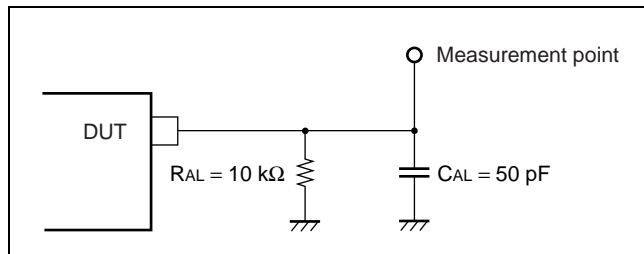

*2: Load condition 2

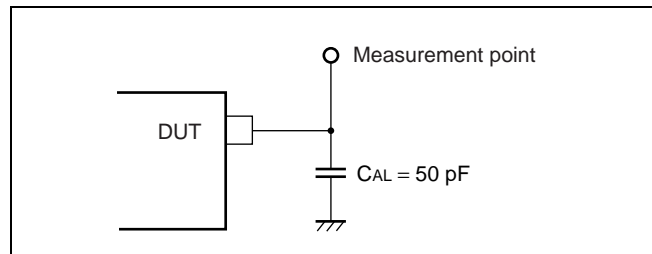

*3 : The I/O expander input open time value applies to a read operation following an I/O write operation, or to an I/O write operation following a read operation.

• Input/Output Timing

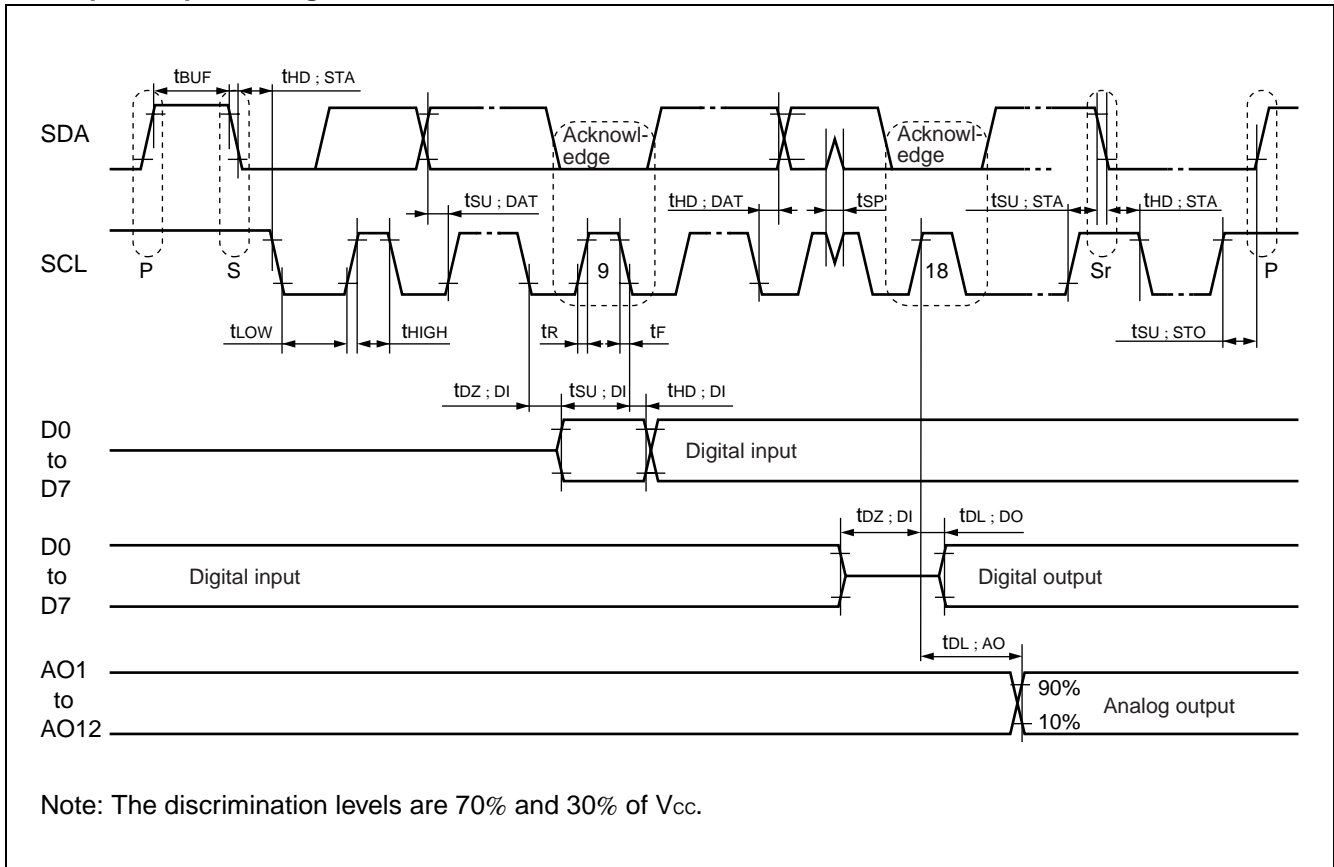

MB88141A

■ ORDERING INFORMATION

Part number	Package	Remarks
MB88141AP	24-pin plastic DIP (DIP-24P-M02)	
MB88141APF	24-pin plastic SOP (FPT-24P-M01)	
MB88141APFV	24-pin plastic SSOP (FPT-24P-M03)	

■ PACKAGE DIMENSIONS

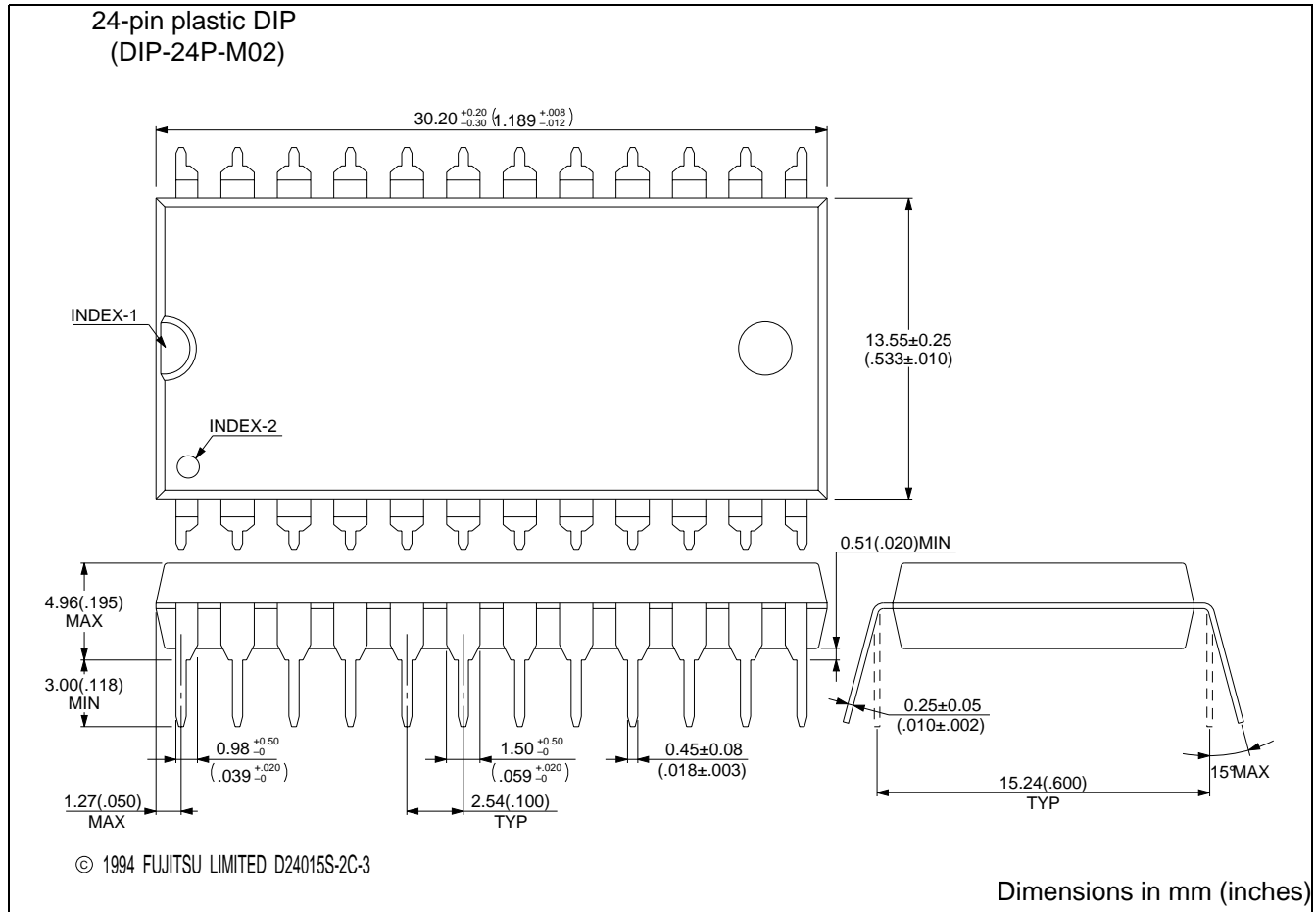

(Continued)

MB88141A

(Continued)

24-pin plastic SOP
(FPT-24P-M01)

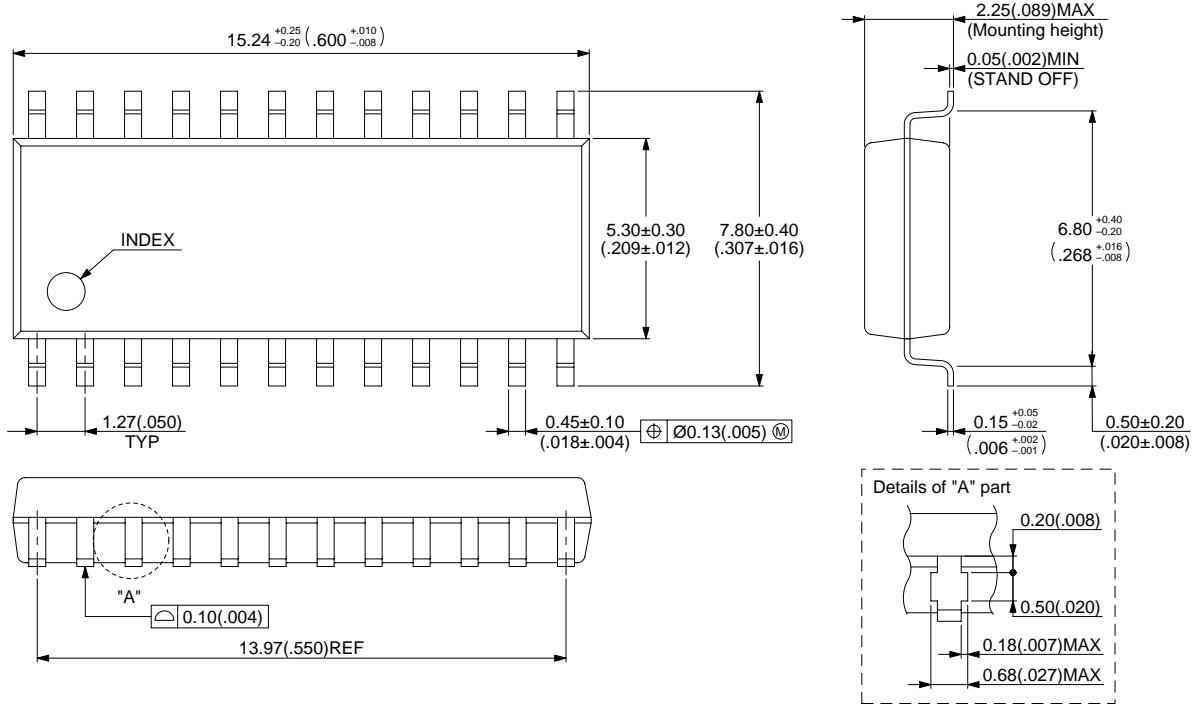

© 2000 FUJITSU LIMITED F24007S-3C-5

Dimensions in mm (inches)

(Continued)

(Continued)

24-pin plastic SSOP
(FPT-24P-M03)

Note) * marked dimensions do not include resin residues.

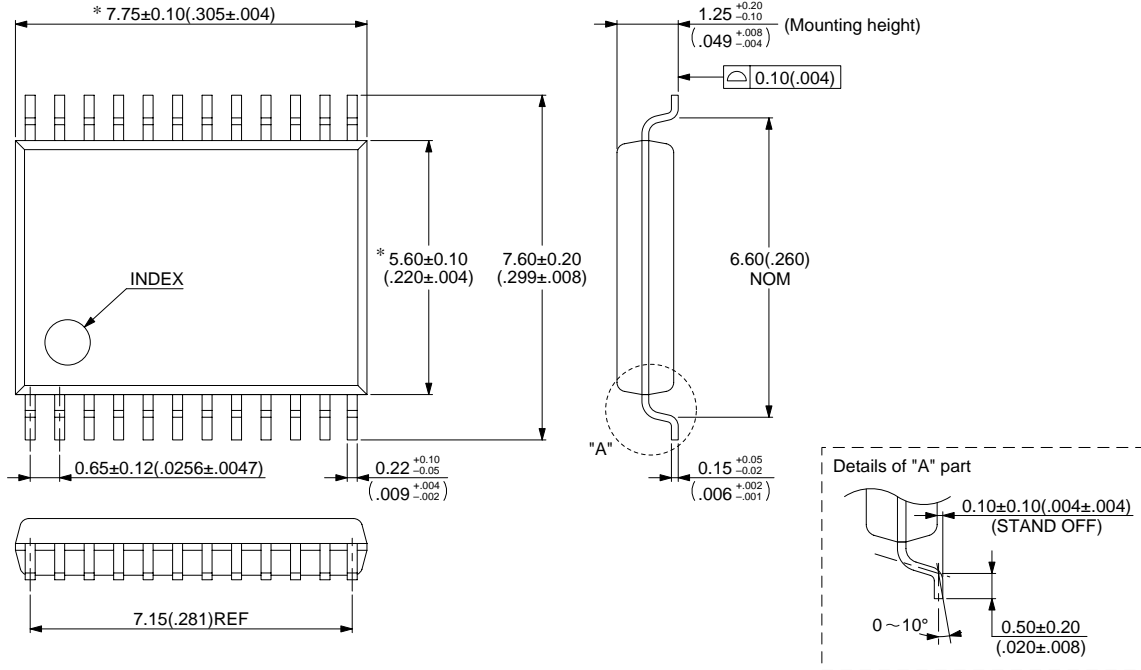

© 2000 FUJITSU LIMITED F24018S-2C-3

Dimensions in mm (inches)

MEMO

MEMO

FUJITSU MICROELECTRONICS LIMITED

Shinjuku Dai-Ichi Seimei Bldg. 7-1, Nishishinjuku 2-chome, Shinjuku-ku,
Tokyo 163-0722, Japan Tel: +81-3-5322-3347 Fax: +81-3-5322-3387
<http://jp.fujitsu.com/fml/en/>

For further information please contact:

North and South America

FUJITSU MICROELECTRONICS AMERICA, INC.
1250 E. Arques Avenue, M/S 333
Sunnyvale, CA 94085-5401, U.S.A.
Tel: +1-408-737-5600 Fax: +1-408-737-5999
<http://www.fma.fujitsu.com/>

Europe

FUJITSU MICROELECTRONICS EUROPE GmbH
Pittlerstrasse 47, 63225 Langen,
Germany
Tel: +49-6103-690-0 Fax: +49-6103-690-122
<http://emea.fujitsu.com/microelectronics/>

Korea

FUJITSU MICROELECTRONICS KOREA LTD.
206 KOSMO TOWER, 1002 Daechi-Dong,
Kangnam-Gu, Seoul 135-280
Korea
Tel: +82-2-3484-7100 Fax: +82-2-3484-7111
<http://www.fmk.fujitsu.com/>

Asia Pacific

FUJITSU MICROELECTRONICS ASIA PTE LTD.
151 Lorong Chuan, #05-08 New Tech Park,
Singapore 556741
Tel: +65-6281-0770 Fax: +65-6281-0220
<http://www.fujitsu.com/sg/services/micro/semiconductor/>

FUJITSU MICROELECTRONICS SHANGHAI CO., LTD.
Rm.3102, Bund Center, No.222 Yan An Road(E),
Shanghai 200002, China
Tel: +86-21-6335-1560 Fax: +86-21-6335-1605
<http://cn.fujitsu.com/fmc/>

FUJITSU MICROELECTRONICS PACIFIC ASIA LTD.
10/F., World Commerce Centre, 11 Canton Road
Tsimshatsui, Kowloon
Hong Kong
Tel: +852-2377-0226 Fax: +852-2376-3269
<http://cn.fujitsu.com/fmc/tw>

All Rights Reserved.

The contents of this document are subject to change without notice.

Customers are advised to consult with sales representatives before ordering.

The information, such as descriptions of function and application circuit examples, in this document are presented solely for the purpose of reference to show examples of operations and uses of FUJITSU MICROELECTRONICS device; FUJITSU MICROELECTRONICS does not warrant proper operation of the device with respect to use based on such information. When you develop equipment incorporating the device based on such information, you must assume any responsibility arising out of such use of the information.

FUJITSU MICROELECTRONICS assumes no liability for any damages whatsoever arising out of the use of the information.

Any information in this document, including descriptions of function and schematic diagrams, shall not be construed as license of the use or exercise of any intellectual property right, such as patent right or copyright, or any other right of FUJITSU MICROELECTRONICS or any third party or does FUJITSU MICROELECTRONICS warrant non-infringement of any third-party's intellectual property right or other right by using such information. FUJITSU MICROELECTRONICS assumes no liability for any infringement of the intellectual property rights or other rights of third parties which would result from the use of information contained herein.

The products described in this document are designed, developed and manufactured as contemplated for general use, including without limitation, ordinary industrial use, general office use, personal use, and household use, but are not designed, developed and manufactured as contemplated (1) for use accompanying fatal risks or dangers that, unless extremely high safety is secured, could have a serious effect to the public, and could lead directly to death, personal injury, severe physical damage or other loss (i.e., nuclear reaction control in nuclear facility, aircraft flight control, air traffic control, mass transport control, medical life support system, missile launch control in weapon system), or (2) for use requiring extremely high reliability (i.e., submersible repeater and artificial satellite).

Please note that FUJITSU MICROELECTRONICS will not be liable against you and/or any third party for any claims or damages arising in connection with above-mentioned uses of the products.

Any semiconductor devices have an inherent chance of failure. You must protect against injury, damage or loss from such failures by incorporating safety design measures into your facility and equipment such as redundancy, fire protection, and prevention of over-current levels and other abnormal operating conditions.

Exportation/release of any products described in this document may require necessary procedures in accordance with the regulations of the Foreign Exchange and Foreign Trade Control Law of Japan and/or US export control laws.

The company names and brand names herein are the trademarks or registered trademarks of their respective owners.