

# TRAILING EDGE PRODUCT - MINIMUM ORDER APPLIES



Elm Road, West Chirton Industrial Estate, North Shields,  
NE29 8SE, ENGLAND. TEL +44 (0191) 2930500. FAX +44 (0191)  
2590997

## 2M x 8 SRAM MODULE

### SYS82000FK - 020/025/35

Issue 1.2 : February 2000

#### Description

The SYS82000FK is a plastic 16Mbit Static RAM Module housed in a JEDEC standard 36 pin Dual In-Line package organised as 2Mx8.

The module utilises 512Kx8 SRAM's housed in SOJ packages, and uses double sided surface mount techniques, buried decoder and dual board construction to achieve a very high density module, emulating the 16Mbit monolithic pinout.

Access times of 20 to 35 ns are available. The  $\overline{OE}$  pin allows faster access times than address access during a read cycle.

#### Features

- Access Times of 20/25/35 ns.
- 36 Pin JEDEC standard Dual-In-Line package.
- 5 Volt Supply  $\pm 10\%$ .
- Low Power Dissipation:  
Average (min cycle) 2.15W (max).  
Standby (-L Version CMOS) 220mW (max).
- Completely Static Operation.
- Low Voltage  $V_{CC}$  Data Retention.
- Equal Access and Cycle Times.
- On-board Supply Decoupling Capacitors.

#### Block Diagram

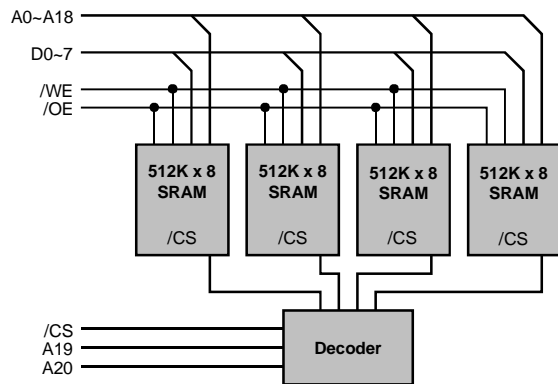

#### Pin Definition

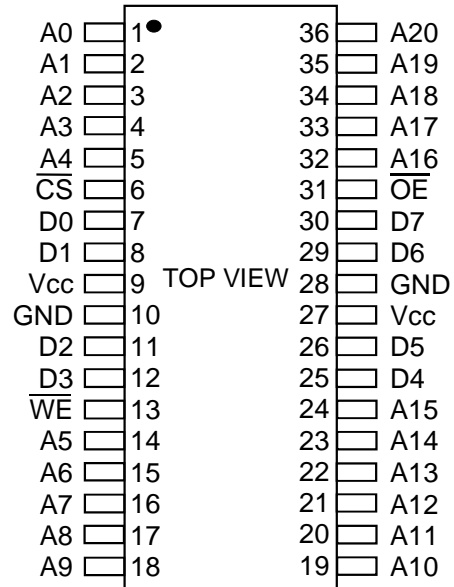

#### Pin Functions

Address Inputs	A0 ~ A20
Data Input/Output	D0 ~ D7
Chip Select	$\overline{CS}$
Write Enable	$\overline{WE}$
Output Enable	$\overline{OE}$
Power (+5V)	$V_{CC}$
Ground	GND

#### Package Details

Plastic 36 Pin 0.6" Dual-In-Line  
Package.(DIP)

**DC OPERATING CONDITIONS****Absolute Maximum Ratings** <sup>(1)</sup>

Parameter	Symbol	Min	Typ	Max	Unit
Voltage on any pin relative to $V_{SS}$	$V_T^{(2)}$	-0.3	-	7.0	V
Power Dissipation	$P_T$	-	1.0	-	W
Storage Temperature	$T_{STG}$	-55	-	125	°C

Notes : (1) Stresses above those listed may cause permanent damage to the device. This is a stress rating only and functional operation of the device at those or any other conditions above those indicated in the operational sections of this specification is not implied. Exposure to absolute maximum rating conditions for extended periods may affect device reliability.

(2)  $V_T$  can be -3.0V pulse of less than 30ns.

**Recommended Operating Conditions**

Parameter	Symbol	Min	Typ	Max	Unit
Supply Voltage	$V_{CC}$	4.5	5.0	5.5	V
Input High Voltage	$V_{IH}$	2.2	-	$V_{CC}+0.3$	V
Input Low Voltage	$V_{IL}$	-0.3	-	0.8	V
Operating Temperature (Commercial)	$T_A$	0	-	70	°C
(Industrial)	$T_{AI}$	-40	-	85	°C

**DC Electrical Characteristics** ( $V_{CC}=5V\pm 10\%$ )  $T_A$  0 to 70 °C

Parameter	Symbol	Test Condition	Min	Typ	max	Unit
I/P Leakage Current Address, $\overline{OE}$ , $\overline{WE}$	$I_{LI}$	$0V \leq V_{IN} \leq V_{CC}$	-20	-	20	$\mu A$
Output Leakage Current	$I_{LO}$	$\overline{CS} = V_{IH}$ , $V_{IO} = GND$ to $V_{CC}$ , $\overline{OE} = V_{IH}$	-20	-	20	$\mu A$
Operating Supply Current	$I_{CC1}$	Min. Cycle, $\overline{CS} = V_{IL}$ , $V_{IL} \leq V_{IN} \leq V_{IH}$	-	-	390	mA
Standby Supply Current TTL levels	$I_{SB1}$	$\overline{CS} = V_{IH}$	-	-	240	mA
CMOS levels	$I_{SB2}$	$\overline{CS} \geq V_{CC}-0.2V$ , $0.2 \leq V_{IN} \leq V_{CC}-0.2V$	-	-	60	mA
Output Voltage	$V_{OL}$	$I_{OL} = 8.0mA$	-	-	0.4	V
	$V_{OH}$	$I_{OH} = -4.0mA$	2.4	-	-	V

Typical values are at  $V_{CC}=5.0V$ ,  $T_A=25^\circ C$  and specified loading.

**Capacitance** ( $V_{CC}=5V\pm 10\%$ ,  $T_A=25^\circ C$ )

Note: Capacitance calculated, not measured.

Parameter	Symbol	Test Condition	max	Unit
Input Capacitance (Address, $\overline{OE}$ , $\overline{WE}$ )	$C_{IN1}$	$V_{IN} = 0V$	35	pF
Input Capacitance (other)	$C_{IN2}$	$V_{IN} = 0V$	10	pF
I/O Capacitance	$C_{IO}$	$V_{IO} = 0V$	47	pF

**AC Test Conditions** **Output Load**

- \* Input pulse levels: 0V to 3.0V
- \* Input rise and fall times: 5ns
- \* Input and Output timing reference levels: 1.5V
- \* Output load: see diagram
- \*  $V_{CC} = 5V \pm 10\%$

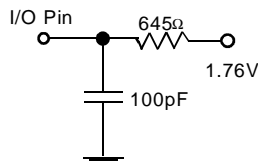

**Operation Truth Table**

$\overline{CS}$	$\overline{OE}$	$\overline{WE}$	DATA PINS	SUPPLY CURRENT	MODE
H	X	X	High Impedance	$I_{SB1}, I_{SB2}$	Standby
L	L	H	Data Out	$I_{CC1}$	Read
L	X	L	Data In	$I_{CC1}$	Write
L	H	H	High-Impedance	$I_{SB1}, I_{SB2}$	High-Z

Notes : H =  $V_{IH}$  : L =  $V_{IL}$  : X =  $V_{IH}$  or  $V_{IL}$

**Low  $V_{CC}$  Data Retention Characteristics - L Version Only**

Parameter	Symbol	Test Condition	min	typ	max	Unit
$V_{CC}$ for Data Retention	$V_{DR}$	$\overline{CS} \geq V_{CC} - 0.2V$	2.0	-	-	V
Data Retention Current	$I_{CCDR1}$	$2.0 \leq V_{CC} \leq 5.5V, \overline{CS} \geq V_{CC} - 0.2$	-	-	2.4	mA
Chip Deselect to Data Retention Time	$t_{CDR}$	See Retention Waveform	0	-	-	ns
Operation Recovery Time	$t_R$	See Retention Waveform	$t_{RC}$	-	-	ms

Notes (1) Figures are measured over the commercial Temp range.

## AC OPERATING CONDITIONS

### Read Cycle

Parameter	Symbol	-020		-025		-035		Unit
		min	max	min	max	min	max	
Read Cycle Time	$t_{RC}$	20	-	25	-	35	-	ns
Address Access Time	$t_{AA}$	-	20	-	25	-	35	ns
Chip Select Access Time	$t_{ACS}$	-	20	-	25	-	35	ns
Output Enable to Output Valid	$t_{OE}$	-	10	-	12	-	14	ns
Output Hold from Address Change	$t_{OH}$	3	-	3	-	5	-	ns
Chip Selection to Output in Low Z	$t_{CLZ}$	0	-	0	-	0	-	ns
Output Enable to Output in Low Z	$t_{OLZ}$	0	-	0	-	0	-	ns
Chip Deselection to O/P in High Z	$t_{CHZ}$	0	9	0	10	0	12	ns
Output Disable to Output in High Z	$t_{OHZ}$	0	9	0	10	0	12	ns

### Write Cycle

Parameter	Symbol	-20		-25		-35		Unit
		min	max	min	max	min	max	
Write Cycle Time	$t_{WC}$	20	-	25	-	35	-	ns
Chip Selection to End of Write	$t_{CW}$	15	-	17	-	20	-	ns
Address Valid to End of Write	$t_{AW}$	15	-	17	-	20	-	ns
Address Setup Time	$t_{AS}$	0	-	0	-	0	-	ns
Write Pulse Width	$t_{WP}$	15	-	17	-	20	-	ns
Write Recovery Time	$t_{WR}$	0	-	0	-	3	-	ns
Write to Output in High Z	$t_{WHZ}$	0	9	0	10	0	15	ns
Data to Write Time Overlap	$t_{DW}$	10	-	12	-	20	-	ns
Data Hold from Write Time	$t_{DH}$	0	-	0	-	0	-	ns
Output active from End of Write	$t_{OW}$	3	-	5	-	5	-	ns

**Read Cycle Timing Waveform** <sup>(1,2)</sup>

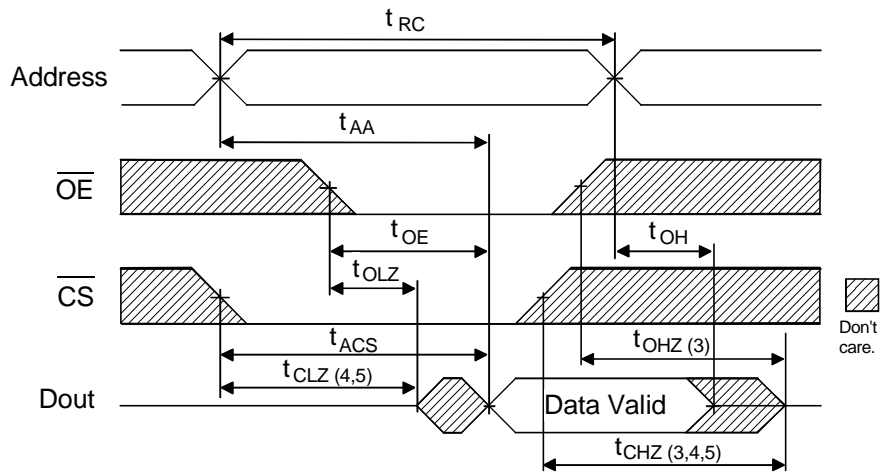

**AC Read Characteristics Notes**

- (1)  $\overline{WE}$  is High for Read Cycle.
- (2) All read cycle timing is referenced from the last valid address to the first transition address.
- (3)  $t_{CHZ}$  and  $t_{OHZ}$  are defined as the time at which the outputs achieve open circuit conditions and are not referenced to output voltage levels.
- (4) At any given temperature and voltage condition,  $t_{CHZ}$  (max) is less than  $t_{CLZ}$  (min) both for a given module and from module to module.
- (5) These parameters are sampled and not 100% tested.

**Write Cycle No.1 Timing Waveform** <sup>(1,4)</sup>

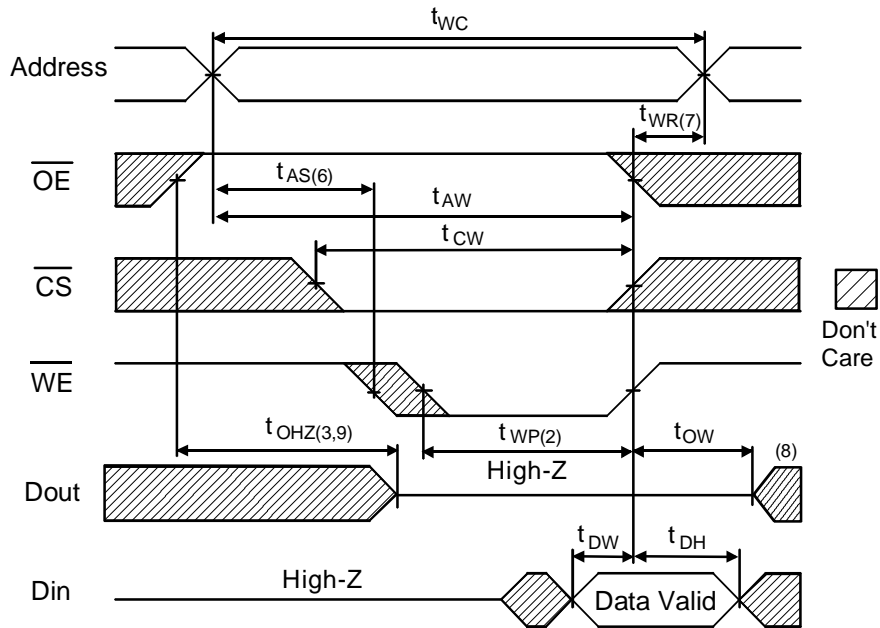



**Package Information**      Dimensions in mm

**Plastic 36 Pin 0.6" Dual-in-Line (DIP)**

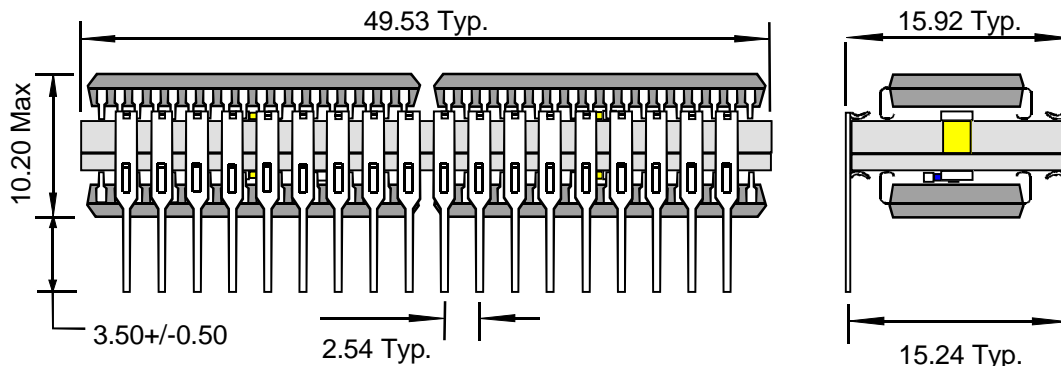

**Ordering Information**

**SYS82000FKLI - 35**

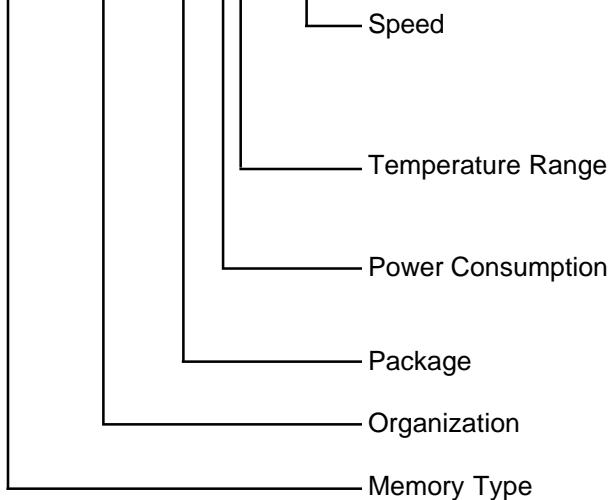

- 020 = 20 ns
- 025 = 25 ns
- 35 = 35 ns
- Blank = Commercial Temperature
- I = Industrial Temperature
- Blank = Standard Part
- L = Low Power Part
- FK = Plastic 36 Pin 0.6" DIP
- 82000 = 2M x 8
- SYS = Static RAM

**Note :**

Although this data is believed to be accurate, the information contained herein is not intended to and does not create any warranty of merchantability or fitness for a particular purpose. Our products are subject to a constant process of development. Data may be changed at any time without notice. Products are not authorised for use as critical components in life support devices without the express written approval of a company director